



FCC Part 15C Test Report

FCC ID: 2AH3JI68

Product Name:	Set Top Box
Trademark:	N/A
Model Name :	I68 MXQ, MXQ PRO, MX9, MXIII, Z4, CS918, M9, MXQ-4K, MX PLUS, NPET, M8S, M8S PRO, M9 PRO.
Prepared For :	Shenzhen Hugsun Technology Co., Ltd.
Address :	4/F, Bldg, 4, Yujingtai Industrial Park, No. 35 Huaxing Rd., Dalang, Longhua ShenZhen, China
Prepared By :	Shenzhen BCTC Technology Co., Ltd.
Address :	No.101, Yousong Road, Longhua New District, Shenzhen, China
Test Date:	Mar. 23 - Mar. 30, 2016
Date of Report :	Mar. 30, 2016
Report No.:	BCTC-160301972E



TEST RESULT CERTIFICATION

Applicant's name..... : Shenzhen Hugsun Technology Co., Ltd.
Address..... : 4/F, Bldg, 4, Yujingtai Industrial Park, No. 35 Huaxing Rd.,
Dalang, Longhua ShenZhen, China

Manufacture's Name..... : Shenzhen Hugsun Technology Co., Ltd.
Address..... : 4/F, Bldg, 4, Yujingtai Industrial Park, No. 35 Huaxing Rd.,
Dalang, Longhua ShenZhen, China

Product description

Product name..... : Set Top Box
Model and/or type reference : I68
Serial Model..... : MXQ, MXQ PRO, MX9, MXIII, Z4, CS918, M9, MXQ-4K, MX
PLUS, NPET, M8S, M8S PRO, M9 PRO.
Test Standards..... : FCC Part15.247
ANSI C63.10-2013

This device described above has been tested by BCTC, and the test results show that the equipment under test (EUT) is in compliance with the FCC requirements. And it is applicable only to the tested sample identified in the report.

This report shall not be reproduced except in full, without the written approval of BCTC, this document may be altered or revised by BCTC, personal only, and shall be noted in the revision of the document.

Testing Engineer : Eric Yang
(Eric Yang)

Technical Manager : Sophie Lu
(Sophia Lee)

Authorized Signatory : Casey Wang
(Casey Wang)



**Table of Contents**

	Page
1 . SUMMARY OF TEST RESULTS	5
1.1 TEST FACILITY	6
1.2 MEASUREMENT UNCERTAINTY	6
2 . GENERAL INFORMATION	7
2.1 GENERAL DESCRIPTION OF EUT	7
2.2 DESCRIPTION OF TEST MODES	9
2.3 BLOCK DIGRAM SHOWING THE CONFIGURATION OF SYSTEM TESTED	10
2.4 DESCRIPTION OF SUPPORT UNITS(CONDUCTED MODE)	11
2.5 EQUIPMENTS LIST FOR ALL TEST ITEMS	12
3 . EMC EMISSION TEST	13
3.1 CONDUCTED EMISSION MEASUREMENT	13
3.1.1 POWER LINE CONDUCTED EMISSION LIMITS	13
3.1.2 TEST PROCEDURE	14
3.1.3 DEVIATION FROM TEST STANDARD	14
3.1.4 TEST SETUP	14
3.1.5 EUT OPERATING CONDITIONS	14
3.1.6 TEST RESULTS	15
3.2 RADIATED EMISSION MEASUREMENT	17
3.2.1 RADIATED EMISSION LIMITS	17
3.2.2 TEST PROCEDURE	18
3.2.3 DEVIATION FROM TEST STANDARD	18
3.2.4 TEST SETUP	19
3.2.5 EUT OPERATING CONDITIONS	20
3.2.6 TEST RESULTS (BETWEEN 9KHZ – 30 MHZ)	21
3.2.7 TEST RESULTS (BETWEEN 30MHZ – 1GHZ)	22
3.2.8 TEST RESULTS (1G-26GHZ)	24
4 . POWER SPECTRAL DENSITY TEST	31
4.1 APPLIED PROCEDURES / LIMIT	31
4.1.1 TEST PROCEDURE	31
4.1.2 DEVIATION FROM STANDARD	31
4.1.3 TEST SETUP	31
4.1.4 EUT OPERATION CONDITIONS	31
4.1.5 TEST RESULTS	32



Table of Contents		Page
5 . BANDWIDTH TEST		38
5.1 APPLIED PROCEDURES / LIMIT		38
5.1.1 TEST PROCEDURE		38
5.1.2 DEVIATION FROM STANDARD		38
5.1.3 TEST SETUP		38
5.1.4 EUT OPERATION CONDITIONS		38
5.1.5 TEST RESULTS		39
6 . PEAK OUTPUT POWER TEST		45
6.1 APPLIED PROCEDURES / LIMIT		45
6.1.1 TEST PROCEDURE		45
6.1.2 DEVIATION FROM STANDARD		45
6.1.3 TEST SETUP		45
6.1.4 EUT OPERATION CONDITIONS		45
6.1.5 TEST RESULTS		46
7 . 100 KHZ BANDWIDTH OF FREQUENCY BAND EDGE		47
7.1 DEVIATION FROM STANDARD		48
7.2 TEST SETUP		49
7.3 EUT OPERATION CONDITIONS		49
7.4 TEST RESULTS		50
8 . DUTY CYCLE OF TEST SIGNAL		54
8.1 STANDARD REQUIREMENT		54
8.2 FORMULA:		54
9 . ANTENNA REQUIREMENT		55
9.1 STANDARD REQUIREMENT		55
9.2 EUT ANTENNA		55
10 . EUT TEST PHOTO		56
11 . EUT PHOTO		58
APPENDIX-PHOTOGRAPHS OF EUT CONSTRUCTIONAL DETAILS		



1. SUMMARY OF TEST RESULTS

Test procedures according to the technical standards:

FCC Part15 (15.247) , Subpart C			
Standard Section	Test Item	Judgment	Remark
15.207	Conducted Emission	PASS	
15.247 (a)(2)	6dB Bandwidth	PASS	
15.247 (b)	Peak Output Power	PASS	
15.247 (c)	Radiated Spurious Emission	PASS	
15.247 (d)	Power Spectral Density	PASS	
15.205	Band Edge Emission	PASS	
15.203	Antenna Requirement	PASS	

NOTE:

(1) "N/A" denotes test is not applicable in this Test Report



1.1 TEST FACILITY

Shenzhen BCTC Technology Co., Ltd.

Add. : No.101, Yousong Road, Longhua New District, Shenzhen, China

FCC Registered No.: 187086

1.2 MEASUREMENT UNCERTAINTY

The reported uncertainty of measurement $y \pm U$, where expanded uncertainty U is based on a standard uncertainty multiplied by a coverage factor of $k=2$, providing a level of confidence of approximately **95 %**.

No.	Item	Uncertainty
1	Conducted Emission Test	$\pm 1.38\text{dB}$
2	RF power, conducted	$\pm 0.16\text{dB}$
3	Spurious emissions, conducted	$\pm 0.21\text{dB}$
4	All emissions, radiated (<1G)	$\pm 4.68\text{dB}$
5	All emissions, radiated (>1G)	$\pm 4.89\text{dB}$
6	Temperature	$\pm 0.5^\circ\text{C}$
7	Humidity	$\pm 2\%$



2. GENERAL INFORMATION

2.1 GENERAL DESCRIPTION OF EUT

Equipment	Set Top Box	
Trade Name	N/A	
Model Name	I68	
Serial Model	MXQ, MXQ PRO, MX9, MXIII, Z4, CS918, M9, MXQ-4K, MX PLUS, NPET, M8S, M8S PRO, M9 PRO.	
Model Difference	All the same, Only model name is different.	
Product Description	The EUT is a Set Top Box	
	Operation Frequency:	802.11b/g/n20MHz:2412~2462 MHz
	Modulation Type:	CCK/OFDM/DBPSK/DAPSK
	Bit Rate of Transmitter	802.11b:11/5.5/2/1 Mbps 802.11g:54/48/36/24/18/12/9/6Mbps 802.11n: Up to 65Mbps
	Number Of Channel	11 CH, Please see Note 2.
	Antenna Designation:	Please see Note 3.
	Output Power(Conducted,AV):	802.11b: 10.83dBm (Max.) 802.11g: 8.64 dBm (Max.) 802.11n(20M) : 7.75dBm (Max.)
	Antenna Gain (dBi)	1.0dbi
	Based on the application, features, or specification exhibited in User's Manual, the EUT is considered as an ITE/Computing Device. More details of EUT technical specification, please refer to the User's Manual.	
Channel List	Please refer to the Note 2.	
Rating(s)	DC 5V	
Adapter	Model: ANU-050200B Input: AC100-240V~ 50/60Hz 0.3A Output: 5V 2000mA	
Connecting I/O Port(s)	Please refer to the User's Manual	

Note:

1. For a more detailed features description, please refer to the manufacturer's specifications or the User's Manual.



2.

Channel List for 802.11b/g/n(20)							
Channel	Frequency (MHz)	Channel	Frequency (MHz)	Channel	Frequency (MHz)	Channel	Frequency (MHz)
01	2412	04	2427	07	2442	10	2457
02	2417	05	2432	08	2447	11	2462
03	2422	06	2437	09	2452		

3.

Table for Filed Antenna

Ant.	Brand	Model Name	Antenna Type	Gain (dBi)	NOTE
A	N/A	N/A	FPCB Antenna	1.0	Wifi Antenna



2.2 DESCRIPTION OF TEST MODES

To investigate the maximum EMI emission characteristics generated from EUT, the test system was pre-scanning tested based on the consideration of following EUT operation mode or test configuration mode which possibly have effect on EMI emission level. Each of these EUT operation mode(s) or test configuration mode(s) mentioned above was evaluated respectively.

Pretest Mode	Description
Mode 1	802.11b CH1/ CH6/ CH11
Mode 2	802.11g CH1/ CH6/ CH11
Mode 3	802.11n CH1/ CH6/ CH11
Mode 4	Link Mode

For Conducted Emission	
Final Test Mode	Description
Mode 4	Link Mode

For Radiated Emission	
Final Test Mode	Description
Mode 1	802.11b CH1/ CH6/ CH11
Mode 2	802.11g CH1/ CH6/ CH11
Mode 3	802.11n CH1/ CH6/ CH11

Note:

- (1) The measurements are performed at the highest, middle, lowest available channels.
- (2) The measurements are performed at all Bit Rate of Transmitter, the worst data was reported

2.3 BLOCK DIGRAM SHOWING THE CONFIGURATION OF SYSTEM TESTED

Conducted Emission Test

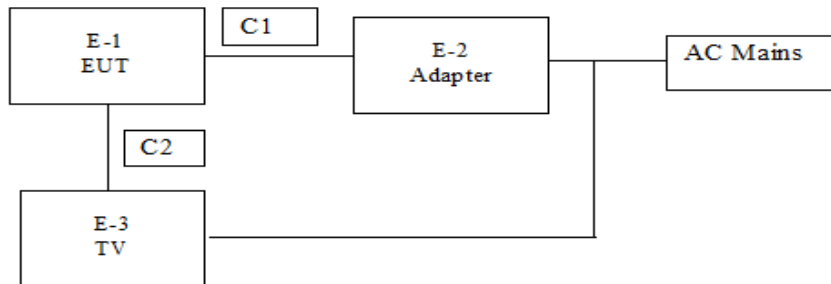

Radiated Spurious Emission Test

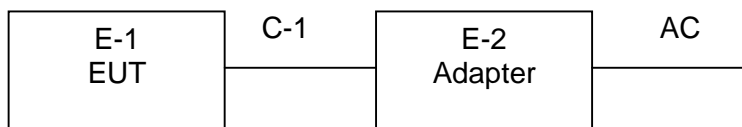



2.4 DESCRIPTION OF SUPPORT UNITS(CONDUCTED MODE)

The EUT has been tested as an independent unit together with other necessary accessories or support units. The following support units or accessories were used to form a representative test configuration during the tests.

Item	Equipment	Mfr/Brand	Model/Type No.	Series No.	Note
E-1	Set Top Box	N/A	I68	N/A	EUT
E-2	Adapter	N/A	ANU-050200B	N/A	
E-3	TV	PHILIPS	24PFL3543/T3	WJ3C1528000141	AC100-240V 50/60Hz 36W

Item	Shielded Type	Ferrite Core	Length	Note
C1	NO	NO	1.0M	DC cable unshielded
C2	NO	NO	1.0M	HDMI cable shielded

Note:

- (1) The support equipment was authorized by Declaration of Confirmation.
- (2) For detachable type I/O cable should be specified the length in cm in 『Length』 column.



2.5 EQUIPMENTS LIST FOR ALL TEST ITEMS

Radiation Test equipment

Item	Kind of Equipment	Manufacturer	Type No.	Serial No.	Last calibration	Calibrated until	Calibration period
1	Spectrum Analyzer	Agilent	E4407B	MY4510957 2	2015.08.25	2016.08.24	1 year
2	Test Receiver	R&S	ESPI	101396	2015.08.25	2016.08.24	1 year
3	Bilog Antenna	SCHWARZBECK	VULB9160	VULB9160- 3369	2015.08.25	2016.08.24	1 year
4	50Ω Coaxial Switch	Anritsu	MP59B	620026441 6	2015.06.07	2016.06.06	1 year
5	Spectrum Analyzer	ADVANTEST	R3132	150900201	2015.06.07	2016.06.06	1 year
6	Horn Antenna	SCHWARZBECK	9120D	9120D-1275	2015.08.25	2016.08.24	1 year
7	Horn Ant	Schwarzbeck	BBHA 9170	9170-181	2015.07.06	2016.07.05	1 year
8	Amplifier	SCHWARZBECK	BBV9718	9718-270	2015.08.25	2016.08.24	1 year
9	Amplifier	SCHWARZBECK	BBV9743	9743-119	2015.08.25	2016.08.24	1 year
10	Loop Antenna	ARA	PLA-1030/B	1029	2015.06.08	2016.06.07	1 year
11	Power Meter	R&S	NRVS	100696	2015.07.06	2016.07.05	1 year
12	Power Sensor	R&S	URV5-Z4	0395.1619. 05	2015.07.06	2016.07.05	1 year
13	RF cables	R&S	N/A	N/A	2015.07.06	2016.07.05	1 year

Conduction Test equipment

Item	Kind of Equipment	Manufacturer	Type No.	Serial No.	Last calibration	Calibrated until	Calibration period
1	Test Receiver	R&S	ESCI	1166.5950K 03-101165- ha	2015.06.05	2016.06.05	1 year
2	LISN	R&S	NSLK81 26	812646 6	2015.08.24	2016.08.23	1 year
3	LISN	R&S	NSLK81 26	812648 7	2015.08.24	2016.08.23	1 year
4	50Ω Coaxial Switch	Anritsu	MP59B	620026441 7	2015.06.05	2016.06.05	1 year
5	RF cables	R&S	R204	R20X	2015.06.05	2016.06.05	1 year



3. EMC EMISSION TEST

3.1 CONDUCTED EMISSION MEASUREMENT

3.1.1 POWER LINE CONDUCTED EMISSION Limits (Frequency Range 150KHz-30MHz)

FREQUENCY (MHz)	Class A (dBuV)		Class B (dBuV)		Standard
	Quasi-peak	Average	Quasi-peak	Average	
0.15 -0.5	79.00	66.00	66 - 56 *	56 - 46 *	CISPR
0.50 -5.0	73.00	60.00	56.00	46.00	CISPR
5.0 -30.0	73.00	60.00	60.00	50.00	CISPR

0.15 -0.5	79.00	66.00	66 - 56 *	56 - 46 *	FCC
0.50 -5.0	73.00	60.00	56.00	46.00	FCC
5.0 -30.0	73.00	60.00	60.00	50.00	FCC

Note:

- (1) The tighter limit applies at the band edges.
- (2) The limit of " * " marked band means the limitation decreases linearly with the logarithm of the frequency in the range.

The following table is the setting of the receiver

Receiver Parameters	Setting
Attenuation	10 dB
Start Frequency	0.15 MHz
Stop Frequency	30 MHz
IF Bandwidth	9 kHz

3.1.2 TEST PROCEDURE

- The EUT was placed 0.8 meters from the horizontal ground plane with EUT being connected to the power mains through a line impedance stabilization network (LISN). All other support equipments powered from additional LISN(s). The LISN provide 50 Ohm/ 50uH of coupling impedance for the measuring instrument.
- Interconnecting cables that hang closer than 40 cm to the ground plane shall be folded back and forth in the center forming a bundle 30 to 40 cm long.
- I/O cables that are not connected to a peripheral shall be bundled in the center. The end of the cable may be terminated, if required, using the correct terminating impedance. The overall length shall not exceed 1 m.
- LISN at least 80 cm from nearest part of EUT chassis.
- For the actual test configuration, please refer to the related Item –EUT Test Photos.

3.1.3 DEVIATION FROM TEST STANDARD

No deviation

3.1.4 TEST SETUP

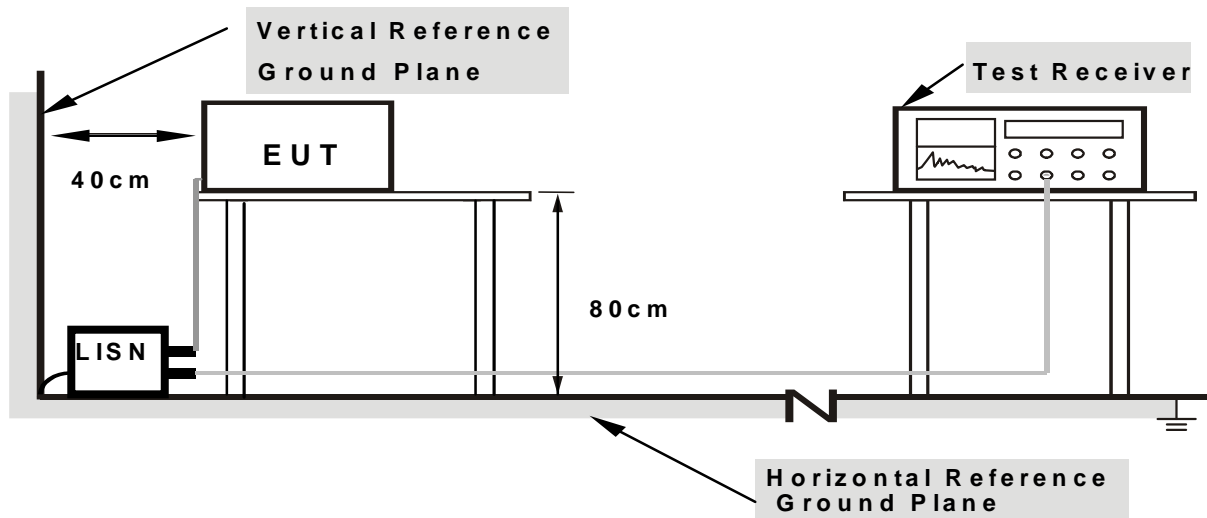

Note: 1.Support units were connected to second LISN.

2.Both of LISNs (AMN) are 80 cm from EUT and at least 80 from other units and other metal planes

3.1.5 EUT OPERATING CONDITIONS

The EUT was configured for testing in a typical fashion (as a customer would normally use it). The EUT has been programmed to continuously transmit during test. This operating condition was tested and used to collect the included data.

We pretest AC 120V and AC 240V, the worst voltage was AC 120V and the data recording in the report.



3.1.6 TEST RESULTS

EUT :	Set Top Box	Model Name. :	I68
Temperature :	25°C	Relative Humidity :	54%
Pressure :	1010hPa	Phase :	L
Test Voltage :	DC 5V from adapter	Test Mode :	Mode 4

Frequency (MHz)	Meter Reading (dBμV)	Factor (dB)	Emission Level (dBμV)	Limits (dBμV)	Margin (dB)	Detector Type
0.2020	39.03	10.07	49.10	63.52	-14.42	QP
0.2020	22.18	10.07	32.25	53.52	-21.27	AVG
0.2580	32.73	10.08	42.81	61.49	-18.68	QP
0.2580	19.40	10.08	29.48	51.49	-22.01	AVG
0.3260	29.89	10.10	39.99	59.55	-19.56	QP
0.3260	17.25	10.10	27.35	49.55	-22.20	AVG
1.5339	25.28	10.17	35.45	56.00	-20.55	QP
1.5339	13.36	10.17	23.53	46.00	-22.47	AVG
7.4740	31.49	10.10	41.59	60.00	-18.41	QP
7.4740	20.39	10.10	30.49	50.00	-19.51	AVG
12.6100	30.13	10.14	40.27	60.00	-19.73	QP
12.6100	19.81	10.14	29.95	50.00	-20.05	AVG

Remark:

1. All readings are Quasi-Peak and Average values.
2. Factor = Insertion Loss + Cable Loss.

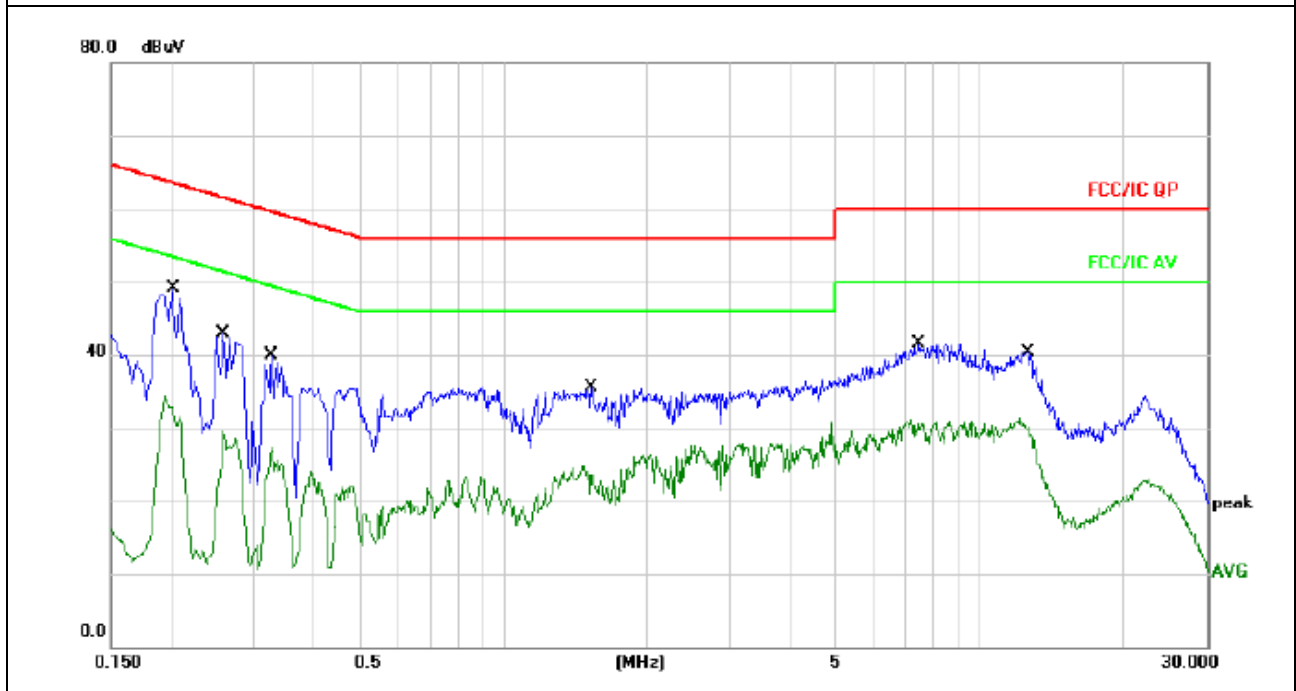



EUT :	Set Top Box	Model Name. :	I68
Temperature :	25°C	Relative Humidity :	54%
Pressure :	1010hPa	Phase :	N
Test Voltage :	DC 5V from adapter	Test Mode :	Mode 4

Frequency (MHz)	Meter Reading (dBμV)	Factor (dB)	Emission Level (dBμV)	Limits (dBμV)	Margin (dB)	Detector Type
0.1900	36.42	10.06	46.48	64.03	-17.55	QP
0.1900	17.71	10.06	27.77	54.03	-26.26	AVG
0.2660	31.00	10.09	41.09	61.24	-20.15	QP
0.2660	12.94	10.09	23.03	51.24	-28.21	AVG
0.3180	26.88	10.10	36.98	59.76	-22.78	QP
0.3180	9.99	10.10	20.09	49.76	-29.67	AVG
2.2820	21.53	10.18	31.71	56.00	-24.29	QP
2.2820	10.07	10.18	20.25	46.00	-25.75	AVG
5.7619	27.95	10.10	38.05	60.00	-21.95	QP
5.7619	13.10	10.10	23.20	50.00	-26.80	AVG
13.0140	25.86	10.14	36.00	60.00	-24.00	QP
13.0140	14.27	10.14	24.41	50.00	-25.59	AVG

Remark:

1. All readings are Quasi-Peak and Average values.
2. Factor = Insertion Loss + Cable Loss.

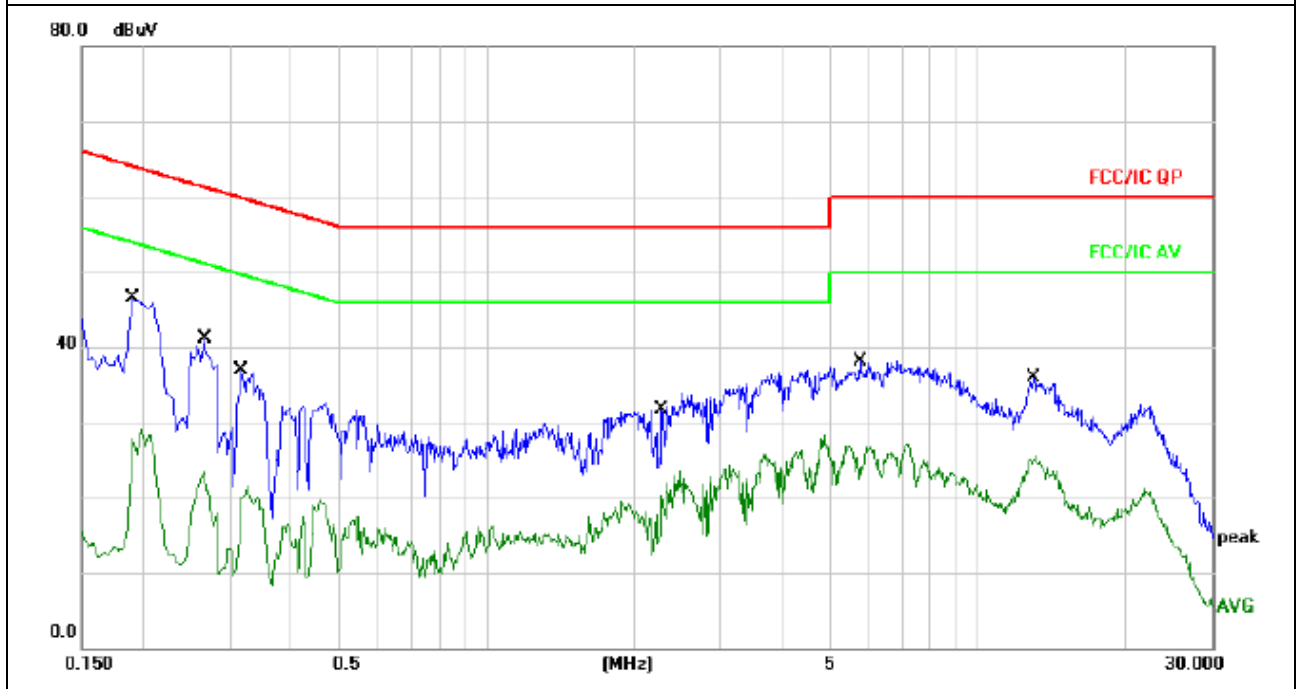



3.2 RADIATED EMISSION MEASUREMENT

3.2.1 RADIATED EMISSION LIMITS (Frequency Range 9kHz-1000MHz)

20dBc in any 100 kHz bandwidth outside the operating frequency band. In case the emission fall within the restricted band specified on 15.205(a), then the 15.209(a) limit in the table below has to be followed.

Frequencies (MHz)	Field Strength (microrvolts/meter)	Measurement Distance (meters)
0.009~0.490	2400/F(KHz)	300
0.490~1.705	24000/F(KHz)	30
1.705~30.0	30	30
30~88	100	3
88~216	150	3
216~960	200	3
Above 960	500	3

LIMITS OF RADIATED EMISSION MEASUREMENT (Above 1000MHz)

FREQUENCY (MHz)	Class B (dBuV/m) (at 3M)	
	PEAK	AVERAGE
Above 1000	74	54

Notes:

- (1) The limit for radiated test was performed according to FCC PART 15C.
- (2) The tighter limit applies at the band edges.
- (3) Emission level (dBuV/m)=20log Emission level (uV/m).

Spectrum Parameter	Setting
Attenuation	Auto
Start Frequency	1000 MHz
Stop Frequency	10th carrier harmonic
RB / VB (emission in restricted band)	1 MHz / 1 MHz for Peak, 1 MHz / 10Hz for Average

Receiver Parameter	Setting
Attenuation	Auto
Start ~ Stop Frequency	9kHz~150kHz / RB 200Hz for QP
Start ~ Stop Frequency	150kHz~30MHz / RB 9kHz for QP
Start ~ Stop Frequency	30MHz~1000MHz / RB 120kHz for QP



3.2.2 TEST PROCEDURE

- a. The measuring distance of at 3 m shall be used for measurements at frequency up to 25GHz. For frequencies above 1GHz, any suitable measuring distance may be used.
- b. The EUT was placed on the top of a rotating table 0.8 and 1.5 meters above the ground at a 3 meter semi-chamber test. The table was rotated 360 degrees to determine the position of the highest radiation.
- c. The height of the equipment or of the substitution antenna shall be 0.8 m; above 1GHz, the height was 1.5m, the height of the test antenna shall vary between 1 m to 4 m. Both horizontal and vertical polarizations of the antenna are set to make the measurement.
- d. The initial step in collecting conducted emission data is a spectrum analyzer peak detector mode pre-scanning the measurement frequency range. Significant peaks are then marked and then Quasi Peak detector mode re-measured.
- e. If the Peak Mode measured value compliance with and lower than Quasi Peak Mode Limit, the EUT shall be deemed to meet QP Limits and then no additional QP Mode measurement performed.
- f. For the actual test configuration, please refer to the related Item –EUT Test Photos.

Note:

Both horizontal and vertical antenna polarities were tested and performed pretest to three orthogonal axis. The worst case emissions were reported

3.2.3 DEVIATION FROM TEST STANDARD

No deviation

3.2.4 TEST SETUP

(A) Radiated Emission Test-Up Frequency Below 30MHz

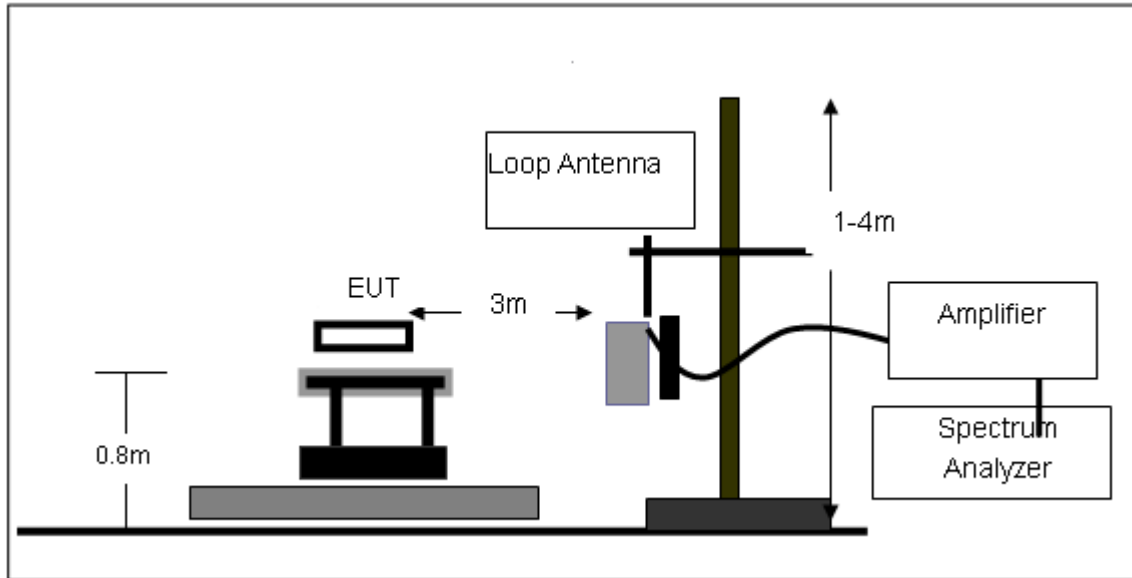

(B) Radiated Emission Test-Up Frequency 30MHz~1GHz

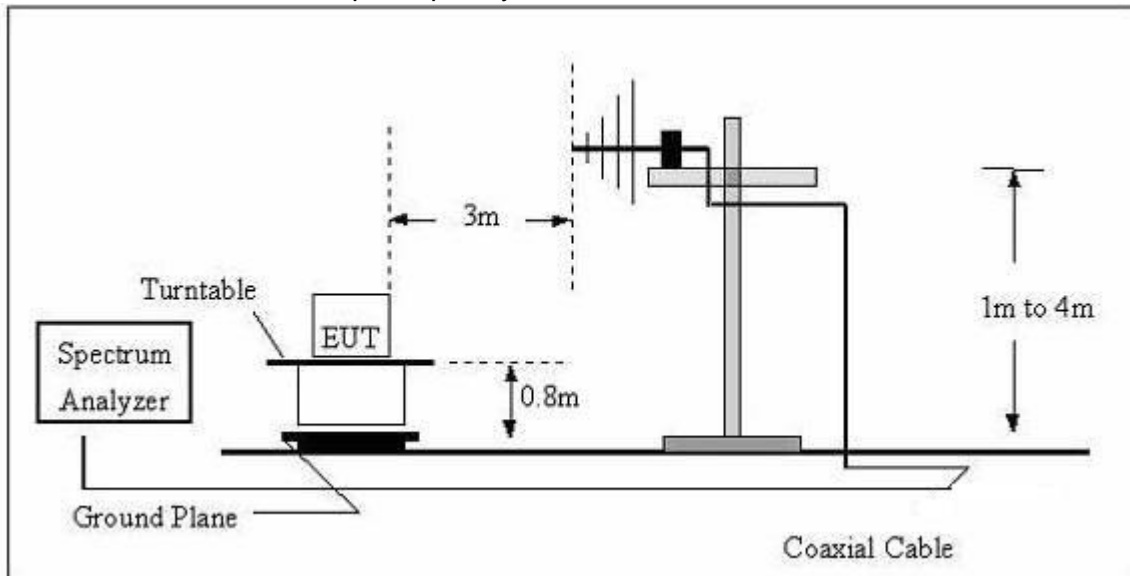

(C) Radiated Emission Test-Up Frequency Above 1GHz

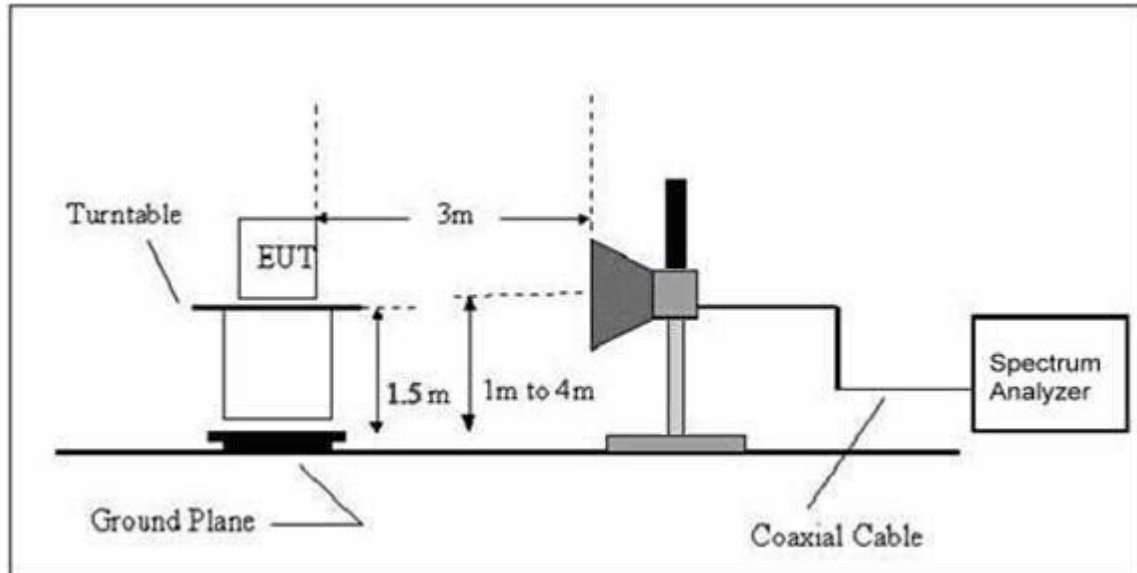

3.2.5 EUT OPERATING CONDITIONS

The EUT tested system was configured as the statements of 2.4 Unless otherwise a special operating condition is specified in the follows during the testing.

**3.2.6 TEST RESULTS (BETWEEN 9KHZ – 30 MHZ)**

EUT:	Set Top Box	Model Name. :	I68
Temperature:	25°C	Relative Humidity:	54%
Pressure:	1010 hPa	Test Voltage :	DC 5V from adapter
Test Mode :	TX	Polarization :	--

Freq. (MHz)	Reading (dBuV/m)	Limit (dBuV/m)	Margin (dB)	State P/F
--	--	--	--	PASS
--	--	--	--	PASS

NOTE:

The amplitude of spurious emissions which are attenuated by more than 20dB below the permissible value has no need to be reported.

Distance extrapolation factor = $40 \log(\text{specific distance}/\text{test distance})$ (dB);

Limit line = specific limits(dBuv) + distance extrapolation factor.



3.2.7 TEST RESULTS (BETWEEN 30MHZ – 1GHZ)

EUT :	Set Top Box	Model Name :	I68
Temperature :	25°C	Relative Humidity :	55%
Pressure :	1010 hPa	Polarization :	Horizontal
Test Voltage :	DC 5V from adapter		
Test Mode :	Mode 4		

Frequency (MHz)	Meter Reading (dBμV)	Factor (dB)	Emission Level (dBμV/m)	Limits (dBμV/m)	Margin (dB)	Detector Type
77.5928	43.70	-17.24	26.46	40.00	-13.54	QP
135.0319	49.53	-13.74	35.79	43.50	-7.71	QP
191.7450	49.42	-15.69	33.73	43.50	-9.77	QP
287.9904	53.47	-12.89	40.58	46.00	-5.42	QP
383.9318	47.95	-10.57	37.38	46.00	-8.62	QP
909.6667	42.12	-1.27	40.85	46.00	-5.15	QP

Remark:
 Factor = Antenna Factor + Cable Loss – Pre-amplifier.
 All interfaces was connected, and BT TX mode was link.

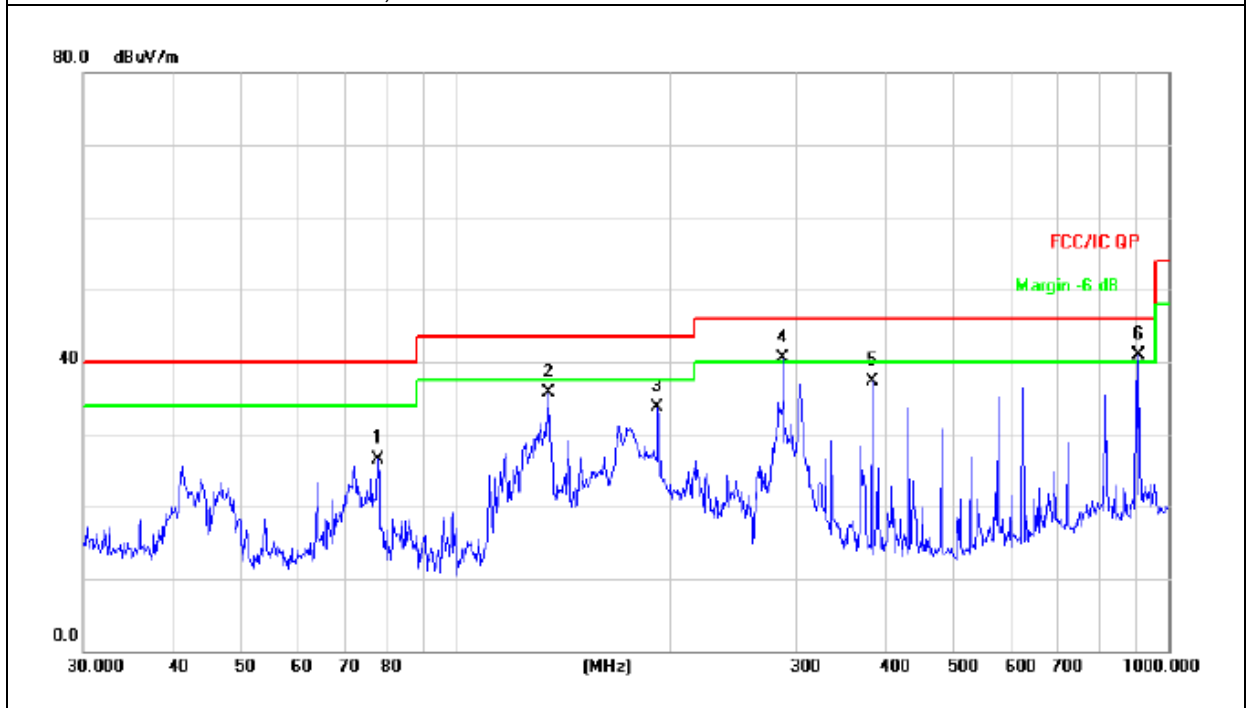



EUT :	Set Top Box	Model Name :	I68
Temperature :	25°C	Relative Humidity :	55%
Pressure :	1010 hPa	Polarization :	Vertical
Test Voltage :	DC 5V from adapter		
Test Mode :	Mode 4		

Frequency (MHz)	Meter Reading (dBμV)	Factor (dB)	Emission Level (dBμV/m)	Limits (dBμV/m)	Margin (dB)	Detector Type
43.3534	46.35	-9.27	37.08	40.00	-2.92	QP
71.8320	48.80	-15.19	33.61	40.00	-6.39	QP
135.0319	47.48	-13.74	33.74	43.50	-9.76	QP
191.7450	45.21	-15.69	29.52	43.50	-13.98	QP
287.9904	45.72	-12.89	32.83	46.00	-13.17	QP
830.4002	39.87	-2.24	37.63	46.00	-8.37	QP

Remark:
 Factor = Antenna Factor + Cable Loss – Pre-amplifier.
 All interfaces was connected, and BT TX mode was link.

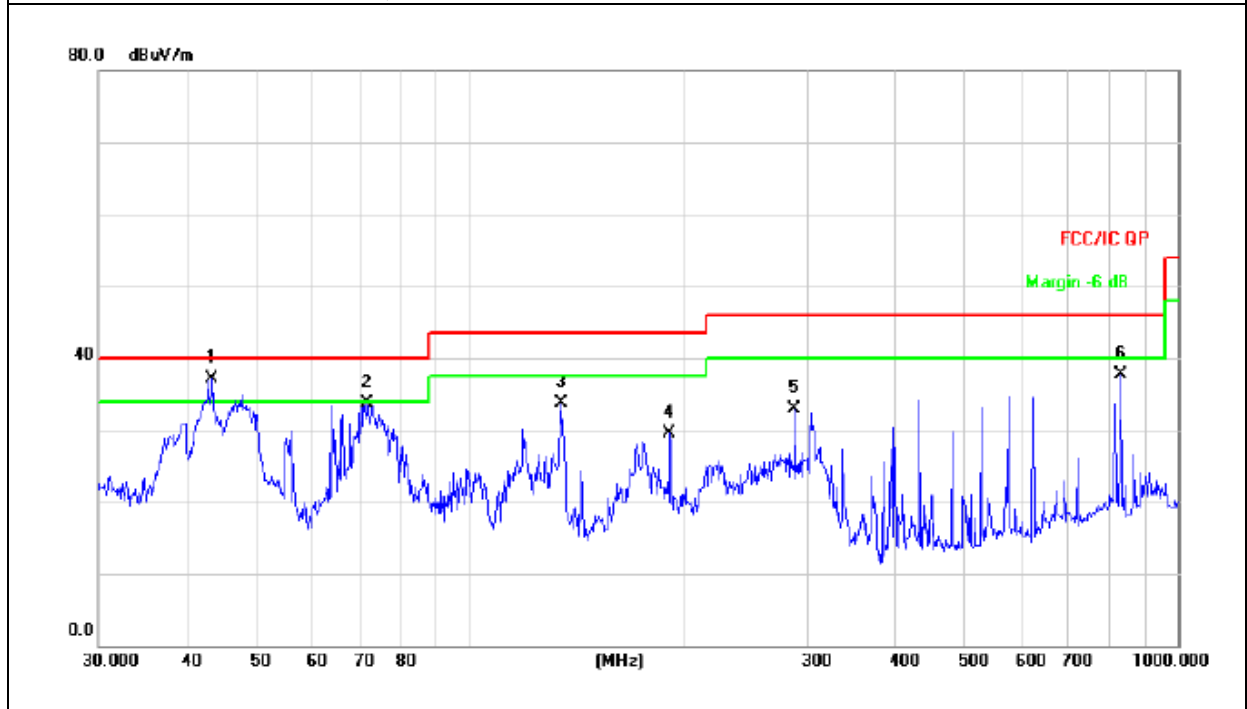



3.2.8 TEST RESULTS (1G-26GHZ)

802.11b

Normal Voltage

Polar (H/V)	Frequency	Meter Reading	Factor	Emission Level	Limits	Margin	Detector Type
	(MHz)	(dBuV)	(dB)	(dBuV/m)	(dBuV/m)	(dB)	
operation frequency:2412							
V	4824.00	44.63	19.36	63.99	74	-10.01	Pk
V	4824.00	25.35	19.36	44.71	54	-9.29	AV
V	7236.00	46.47	17.17	63.64	74	-10.36	Pk
V	7236.00	26.22	17.17	43.39	54	-10.61	AV
V	11650.00	24.56	17.81	42.37	74	-31.63	Pk
V	17850.00	19.23	25.39	44.62	74	-29.38	Pk
H	4824.00	45.13	19.36	64.49	74	-9.51	Pk
H	4824.00	26.45	19.36	45.81	54	-8.19	AV
H	7236.00	46.63	17.17	63.8	74	-10.20	Pk
H	7236.00	26.34	17.17	43.51	54	-10.49	AV
H	11650.00	24.22	17.81	42.03	74	-31.97	Pk
H	17850.00	19.53	25.39	44.92	74	-29.08	Pk

Remark:

Absolute Level= ReadingLevel+ Factor

Margin= Limit- Absolute Level

Other harmonics emissions are lower than 20dB below the allowable limit.

802.11b

Normal Voltage

Polar (H/V)	Frequency	Meter Reading	Factor	Emission Level	Limits	Margin	Detector Type
	(MHz)	(dBuV)	(dB)	(dBuV/m)	(dBuV/m)	(dB)	
operation frequency:2437							
V	4874.00	46.86	19.42	66.28	74	-7.72	Pk
V	4874.00	24.34	19.42	43.76	54	-10.24	AV
V	7311.00	47.39	17.19	64.58	74	-9.42	Pk
V	7311.00	27.41	17.19	44.60	54	-9.40	AV
V	11650.00	25.62	17.81	43.43	74	-30.57	Pk
V	17850.00	19.84	25.39	45.23	74	-28.77	Pk
H	4874.00	46.64	19.42	66.06	74	-7.94	Pk
H	4874.00	26.48	19.42	45.90	54	-8.10	AV
H	7311.00	47.63	17.19	64.82	74	-9.18	Pk
H	7311.00	27.24	17.19	44.43	54	-9.57	AV
H	11650.00	24.57	17.81	42.38	74	-31.62	Pk
H	17850.00	19.03	25.39	44.42	74	-29.58	Pk

Remark:

Absolute Level= ReadingLevel+ Factor

Margin= Limit- Absolute Level

Other harmonics emissions are lower than 20dB below the allowable limit.



802.11b

Normal Voltage

Polar (H/V)	Frequency	Meter Reading	Factor	Emission Level	Limits	Margin	Detector Type
	(MHz)	(dBuV)	(dB)	(dBuV/m)	(dBuV/m)	(dB)	
operation frequency:2462							
V	4924.00	45.98	19.47	65.45	74	-8.55	Pk
V	4924.00	25.26	19.47	44.73	54	-9.27	AV
V	7386.00	47.44	17.22	64.66	74	-9.34	Pk
V	7386.00	26.63	17.22	43.85	54	-10.15	AV
V	11650.00	24.22	17.81	42.03	74	-31.97	Pk
V	17850.00	18.34	25.39	43.73	74	-30.27	Pk
H	4924.00	45.73	19.47	65.20	74	-8.80	Pk
H	4924.00	26.26	19.47	45.73	54	-8.27	AV
H	7386.00	46.45	17.22	63.67	74	-10.33	Pk
H	7386.00	26.64	17.22	43.86	54	-10.14	AV
H	11650.00	24.37	17.81	42.18	74	-31.82	Pk
H	17850.00	18.43	25.39	43.82	74	-30.18	Pk
<p>Remark: Absolute Level= ReadingLevel+ Factor Margin= Limit- Absolute Level Other harmonics emissions are lower than 20dB below the allowable limit.</p>							



802.11g

Normal Voltage

Polar (H/V)	Frequency	Meter Reading	Factor	Emission Level	Limits	Margin	Detector Type
	(MHz)	(dBuV)	(dB)	(dBuV/m)	(dBuV/m)	(dB)	
operation frequency:2412							
V	4824.00	46.25	19.36	65.61	74	-8.39	Pk
V	4824.00	26.71	19.36	46.07	54	-7.93	AV
V	7236.00	47.42	17.17	64.59	74	-9.41	Pk
V	7236.00	26.57	17.17	43.74	54	-10.26	AV
V	11650.00	24.21	17.81	42.02	74	-31.98	Pk
V	17850.00	18.54	25.39	43.93	74	-30.07	Pk
H	4824.00	46.17	19.36	65.53	74	-8.47	Pk
H	4824.00	26.23	19.36	45.59	54	-8.41	AV
H	7236.00	47.31	17.17	64.48	74	-9.52	Pk
H	7236.00	27.42	17.17	44.59	54	-9.41	AV
H	11650.00	24.63	17.81	42.44	74	-31.56	Pk
H	17850.00	19.26	25.39	44.65	74	-29.35	Pk
Remark:							
Absolute Level= ReadingLevel+ Factor							
Margin= Limit- Absolute Level							
Other harmonics emissions are lower than 20dB below the allowable limit.							

802.11g

Normal Voltage

Polar (H/V)	Frequency	Meter Reading	Factor	Emission Level	Limits	Margin	Detector Type
	(MHz)	(dBuV)	(dB)	(dBuV/m)	(dBuV/m)	(dB)	
operation frequency:2437							
V	4874.00	46.76	19.42	66.18	74	-7.82	Pk
V	4874.00	24.29	19.42	43.71	54	-10.29	AV
V	7311.00	47.34	17.19	64.53	74	-9.47	Pk
V	7311.00	27.36	17.19	44.55	54	-9.45	AV
V	11650.00	25.57	17.81	43.38	74	-30.62	Pk
V	17850.00	19.69	25.39	45.08	74	-28.92	Pk
H	4874.00	46.58	19.42	66.00	74	-8.00	Pk
H	4874.00	26.43	19.42	45.85	54	-8.15	AV
H	7311.00	47.56	17.19	64.75	74	-9.25	Pk
H	7311.00	27.19	17.19	44.38	54	-9.62	AV
H	11650.00	24.51	17.81	42.32	74	-31.68	Pk
H	17850.00	18.97	25.39	44.36	74	-29.64	Pk
Remark:							
Absolute Level= ReadingLevel+ Factor							
Margin= Limit- Absolute Level							
Other harmonics emissions are lower than 20dB below the allowable limit.							



802.11g

Normal Voltage

Polar (H/V)	Frequency	Meter Reading	Factor	Emission Level	Limits	Margin	Detector Type
	(MHz)	(dBuV)	(dB)	(dBuV/m)	(dBuV/m)	(dB)	
operation frequency:2462							
V	4924.00	45.92	19.47	65.39	74	-8.61	Pk
V	4924.00	25.21	19.47	44.68	54	-9.32	AV
V	7386.00	47.38	17.22	64.60	74	-9.40	Pk
V	7386.00	26.55	17.22	43.77	54	-10.23	AV
V	11650.00	24.06	17.81	41.87	74	-32.13	Pk
V	17850.00	18.28	25.39	43.67	74	-30.33	Pk
H	4924.00	45.66	19.47	65.13	74	-8.87	Pk
H	4924.00	26.19	19.47	45.66	54	-8.34	AV
H	7386.00	46.38	17.22	63.60	74	-10.40	Pk
H	7386.00	26.57	17.22	43.79	54	-10.21	AV
H	11650.00	24.31	17.81	42.12	74	-31.88	Pk
H	17850.00	18.36	25.39	43.75	74	-30.25	Pk

Remark:

Absolute Level= ReadingLevel+ Factor

Margin= Limit- Absolute Level

Other harmonics emissions are lower than 20dB below the allowable limit.



802.11 n(20)

Normal Voltage

Polar (H/V)	Frequency	Meter Reading	Factor	Emission Level	Limits	Margin	Detector Type
	(MHz)	(dBuV)	(dB)	(dBuV/m)	(dBuV/m)	(dB)	
operation frequency:2412							
V	4824.00	46.18	19.36	65.54	74	-8.46	Pk
V	4824.00	26.63	19.36	45.99	54	-8.01	AV
V	7236.00	47.29	17.17	64.46	74	-9.54	Pk
V	7236.00	26.49	17.17	43.66	54	-10.34	AV
V	11650.00	24.26	17.81	42.07	74	-31.93	Pk
V	17850.00	18.47	25.39	43.86	74	-30.14	Pk
H	4824.00	46.35	19.36	65.71	74	-8.29	Pk
H	4824.00	26.19	19.36	45.55	54	-8.45	AV
H	7236.00	47.28	17.17	64.45	74	-9.55	Pk
H	7236.00	27.31	17.17	44.48	54	-9.52	AV
H	11650.00	24.45	17.81	42.26	74	-31.74	Pk
H	17850.00	19.11	25.39	44.50	74	-29.50	Pk
Remark:							
Absolute Level= ReadingLevel+ Factor							
Margin= Limit- Absolute Level							
Other harmonics emissions are lower than 20dB below the allowable limit.							

802.11n(20)

Normal Voltage

Polar (H/V)	Frequency	Meter Reading	Factor	Emission Level	Limits	Margin	Detector Type
	(MHz)	(dBuV)	(dB)	(dBuV/m)	(dBuV/m)	(dB)	
operation frequency:2437							
V	4874.00	45.84	19.42	65.26	74	-8.74	Pk
V	4874.00	24.22	19.42	43.64	54	-10.36	AV
V	7311.00	47.24	17.19	64.43	74	-9.57	Pk
V	7311.00	27.27	17.19	44.46	54	-9.54	AV
V	11650.00	25.46	17.81	43.27	74	-30.73	Pk
V	17850.00	19.62	25.39	45.01	74	-28.99	Pk
H	4874.00	46.51	19.42	65.93	74	-8.07	Pk
H	4874.00	26.38	19.42	45.80	54	-8.20	AV
H	7311.00	47.44	17.19	64.63	74	-9.37	Pk
H	7311.00	27.12	17.19	44.31	54	-9.69	AV
H	11650.00	24.53	17.81	42.34	74	-31.66	Pk
H	17850.00	18.94	25.39	44.33	74	-29.67	Pk
Remark:							
Absolute Level= ReadingLevel+ Factor							
Margin= Limit- Absolute Level							
Other harmonics emissions are lower than 20dB below the allowable limit.							



802.11 n(20)

Normal Voltage

Polar (H/V)	Frequency	Meter Reading	Factor	Emission Level	Limits	Margin	Detector Type
	(MHz)	(dBuV)	(dB)	(dBuV/m)	(dBuV/m)	(dB)	
operation frequency:2462							
V	4924.00	45.72	19.47	65.19	74	-8.81	Pk
V	4924.00	25.26	19.47	44.73	54	-9.27	AV
V	7386.00	47.32	17.22	64.54	74	-9.46	Pk
V	7376.00	26.53	17.22	43.75	54	-10.25	AV
V	11650.00	24.16	17.81	41.97	74	-32.03	Pk
V	17850.00	18.27	25.39	43.66	74	-30.34	Pk
H	4924.00	45.64	19.47	65.11	74	-8.89	Pk
H	4924.00	26.12	19.47	45.59	54	-8.41	AV
H	7386.00	46.33	17.22	63.55	74	-10.45	Pk
H	7376.00	26.63	17.22	43.85	54	-10.15	AV
H	11650.00	24.38	17.81	42.19	74	-31.81	Pk
H	17850.00	18.47	25.39	43.86	74	-30.14	Pk
Remark:							
Absolute Level= ReadingLevel+ Factor							
Margin= Limit- Absolute Level							
Other harmonics emissions are lower than 20dB below the allowable limit.							



Band Radiated

	Frequency (MHz)	Antenna polarization (H/V)	Frequency (MHz)	Meter Reading (dBμV)	Factor (dB)	Emission (dBuV/m)	Band edge Limit (dBuV/m)		Result
						PK	PK	AV	
802.11b	<2400	H	2390.00	35.15	13.83	48.98	74.00	54.00	Pass
	<2400	V	2390.00	34.64	13.83	48.47	74.00	54.00	Pass
	<2400	H	2400.00	34.48	13.85	48.33	74.00	54.00	Pass
	<2400	V	2400.00	34.56	13.85	48.41	74.00	54.00	Pass
	>2483.5	H	2483.50	33.92	14.02	47.94	74.00	54.00	Pass
	>2483.5	V	2483.50	34.38	14.02	48.40	74.00	54.00	Pass
	>2483.5	H	2485.30	34.56	14.04	48.60	74.00	54.00	Pass
802.11g	<2400	H	2390.00	34.49	13.83	48.32	74.00	54.00	Pass
	<2400	V	2390.00	33.58	13.83	47.41	74.00	54.00	Pass
	<2400	H	2400.00	34.25	13.85	48.10	74.00	54.00	Pass
	<2400	V	2400.00	33.81	13.85	47.66	74.00	54.00	Pass
	>2483.5	H	2483.50	33.82	14.02	47.84	74.00	54.00	Pass
	>2483.5	V	2483.50	33.94	14.02	47.96	74.00	54.00	Pass
	>2483.5	H	2485.30	33.55	14.04	47.59	74.00	54.00	Pass
802.11n (20)	<2400	H	2390.00	34.80	13.83	48.63	74.00	54.00	Pass
	<2400	V	2390.00	34.53	13.83	48.36	74.00	54.00	Pass
	<2400	H	2400.00	35.25	13.85	49.10	74.00	54.00	Pass
	<2400	V	2400.00	34.58	13.85	48.43	74.00	54.00	Pass
	>2483.5	H	2483.50	34.25	14.02	48.27	74.00	54.00	Pass
	>2483.5	V	2483.50	34.65	14.02	48.67	74.00	54.00	Pass
	>2483.5	H	2485.30	35.12	14.04	49.16	74.00	54.00	Pass
Remark: Factor = Antenna Factor + Cable Loss – Pre-amplifier. Emission Level = Meter Reading + Factor									

If the PK measured levels comply with average limit, then the average level were deemed to comply with average limit.



4. POWER SPECTRAL DENSITY TEST

4.1 APPLIED PROCEDURES / LIMIT

FCC Part15 (15.247) , Subpart C				
Section	Test Item	Limit	Frequency Range (MHz)	Result
15.247	Power Spectral Density	8 dBm (in any 3KHz)	2400-2483.5	PASS

4.1.1 TEST PROCEDURE

1. Set analyzer center frequency to DTS channel center frequency.
2. Set the span to 1.5 times the DTS bandwidth.
3. Set the RBW to: $3 \text{ kHz} \leq \text{RBW} \leq 100 \text{ kHz}$.
4. Set the VBW $\geq 3 \times \text{RBW}$.
5. Detector = peak.
6. Sweep time = auto couple.
7. Trace mode = max hold.
8. Allow trace to fully stabilize.
9. Use the peak marker function to determine the maximum amplitude level within the RBW.
10. If measured value exceeds limit, reduce RBW (no less than 3 kHz) and repeat.

4.1.2 DEVIATION FROM STANDARD

No deviation.

4.1.3 TEST SETUP



4.1.4 EUT OPERATION CONDITIONS

The EUT tested system was configured as the statements of 2.1 Unless otherwise a special operating condition is specified in the follows during the testing.



4.1.5 TEST RESULTS

EUT :	Set Top Box	Model Name :	I68
Temperature :	25°C	Relative Humidity :	54%
Pressure :	1015 hPa	Test Voltage :	DC 5V from adapter
Test Mode :	TX b Mode /CH01, CH06, CH11		

Frequency	Power Density (dBm)	Limit (dBm)	Result
2412 MHz	-11.19	8	PASS
2437 MHz	-12.24	8	PASS
2462 MHz	-10.34	8	PASS

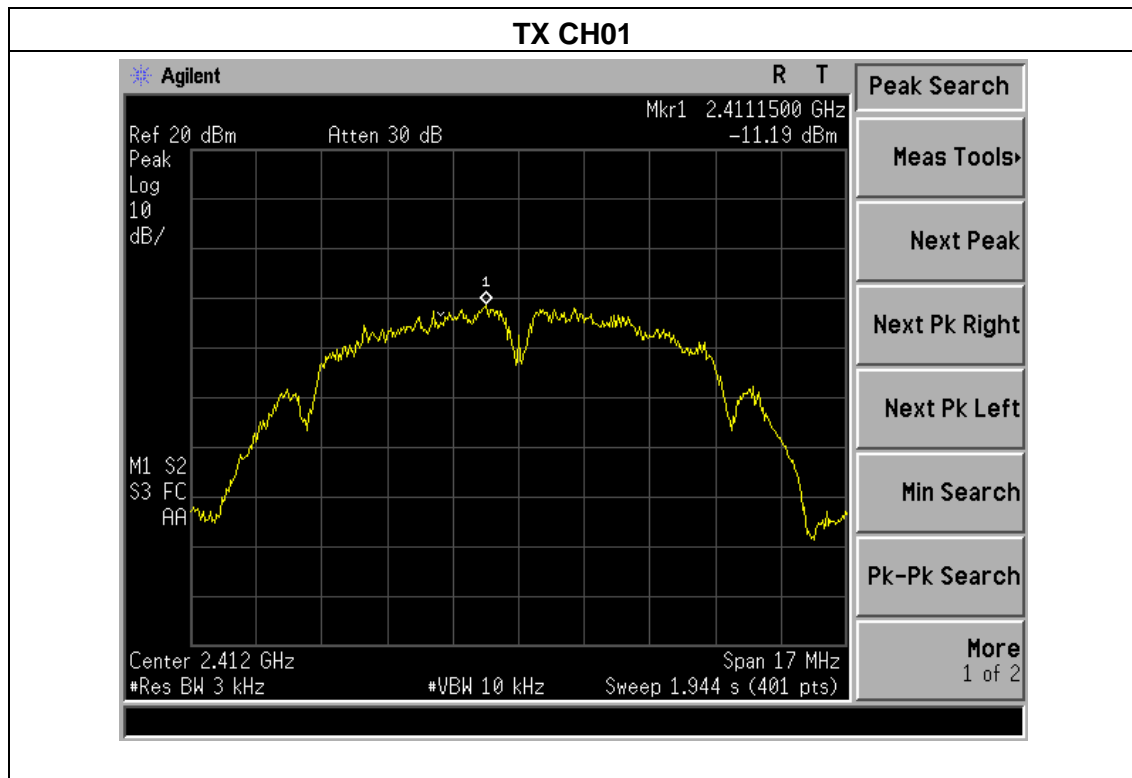

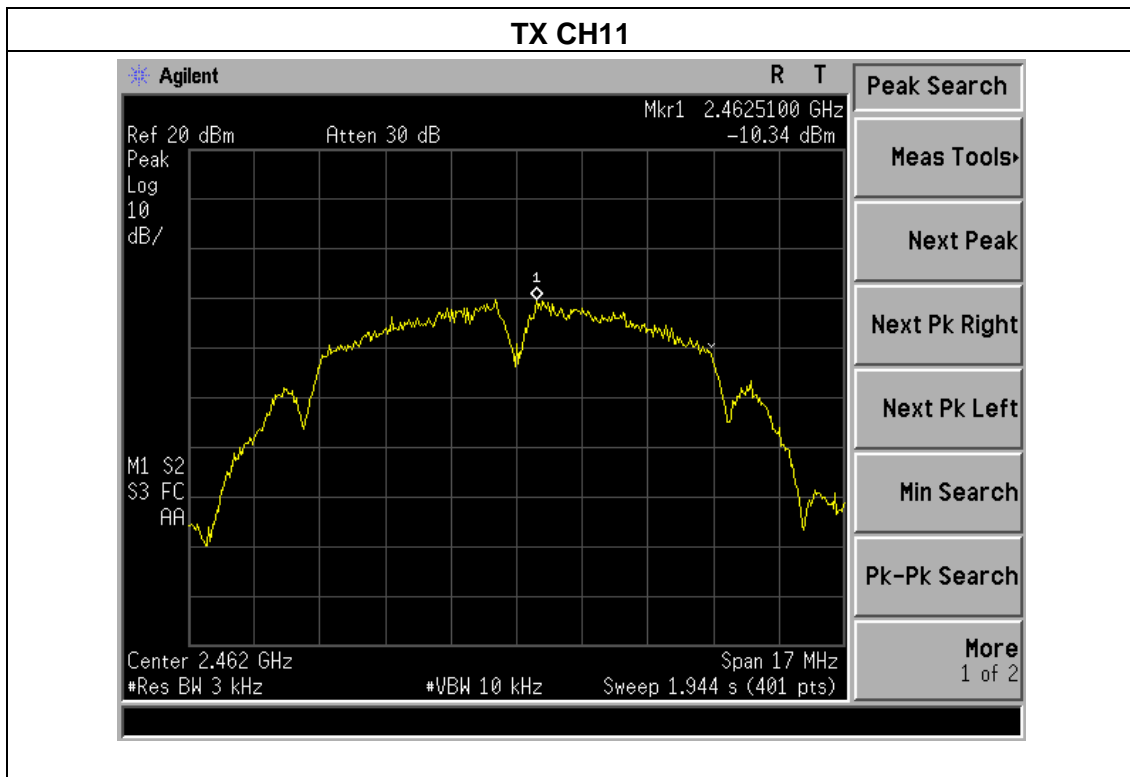
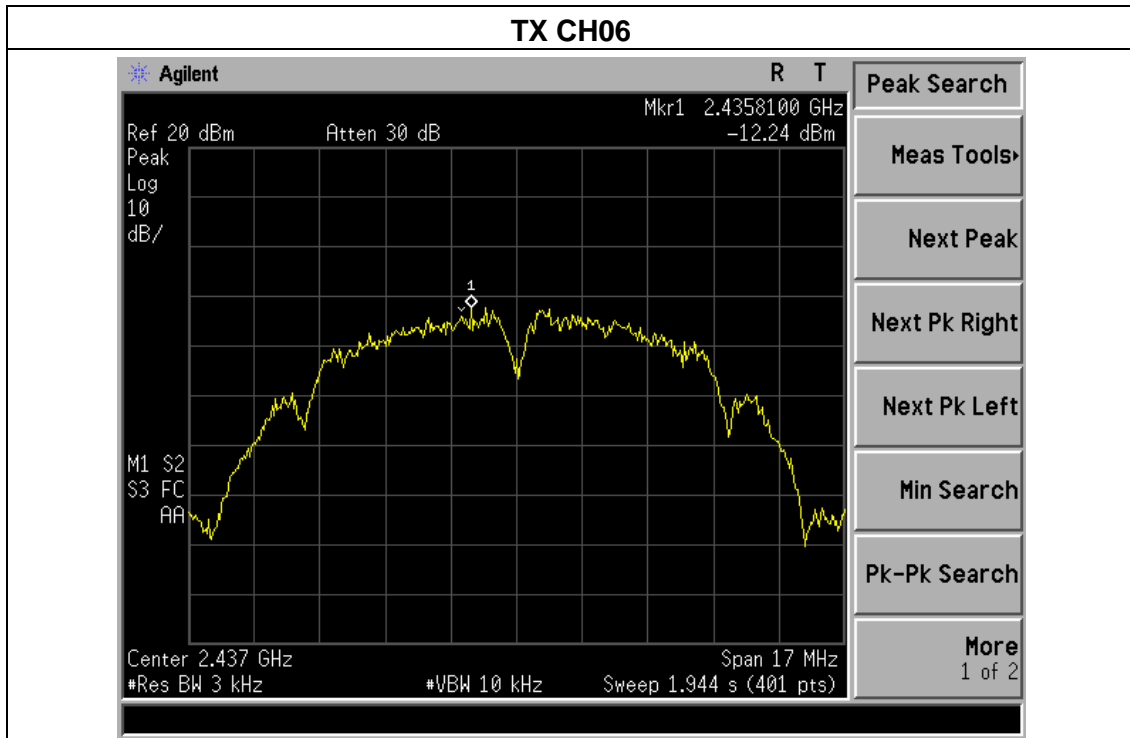



EUT :	Set Top Box	Model Name :	I68
Temperature :	25°C	Relative Humidity :	54%
Pressure :	1015 hPa	Test Voltage :	DC 5V from adapter
Test Mode :	TX g Mode /CH01, CH06, CH11		

Frequency	Power Density (dBm)	Limit (dBm)	Result
2412 MHz	-13.78	8	PASS
2437 MHz	-15.30	8	PASS
2462 MHz	-17.04	8	PASS

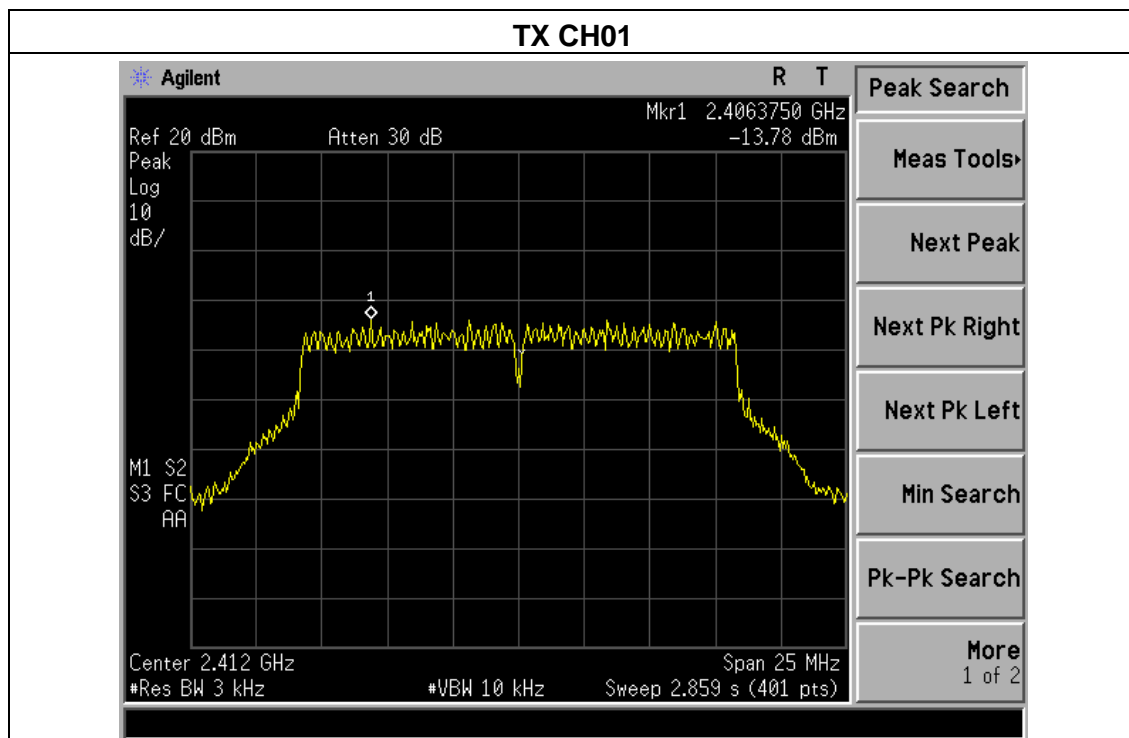

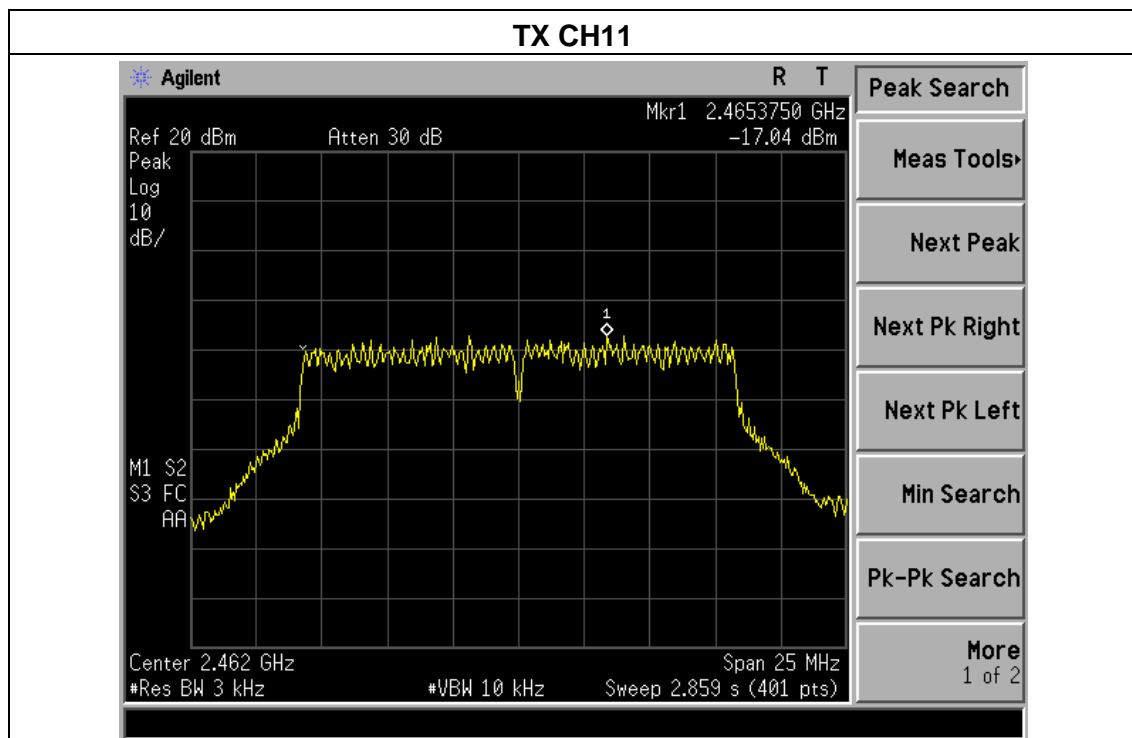
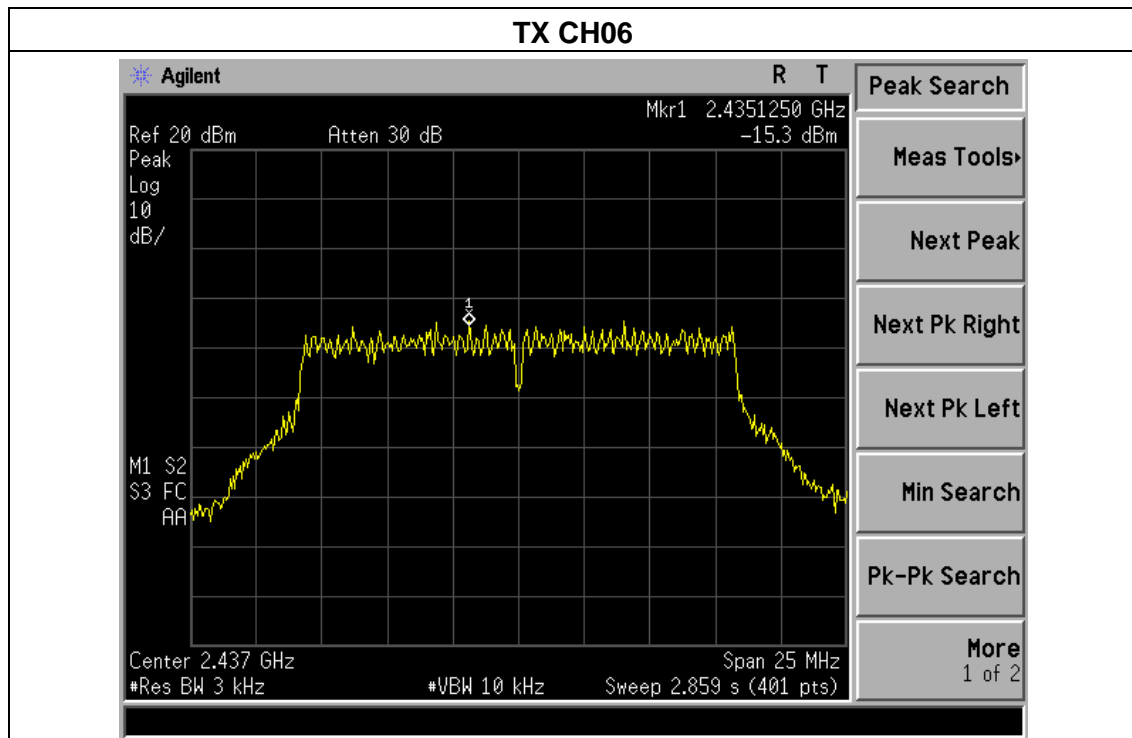



EUT :	Set Top Box	Model Name :	I68
Temperature :	25°C	Relative Humidity :	54%
Pressure :	1015 hPa	Test Voltage :	DC 5V from adapter
Test Mode :	TX n Mode(20M) /CH01, CH06, CH11		

Frequency	Power Density (dBm)	Limit (dBm)	Result
2412 MHz	-17.75	8	PASS
2437 MHz	-15.14	8	PASS
2462 MHz	-14.66	8	PASS

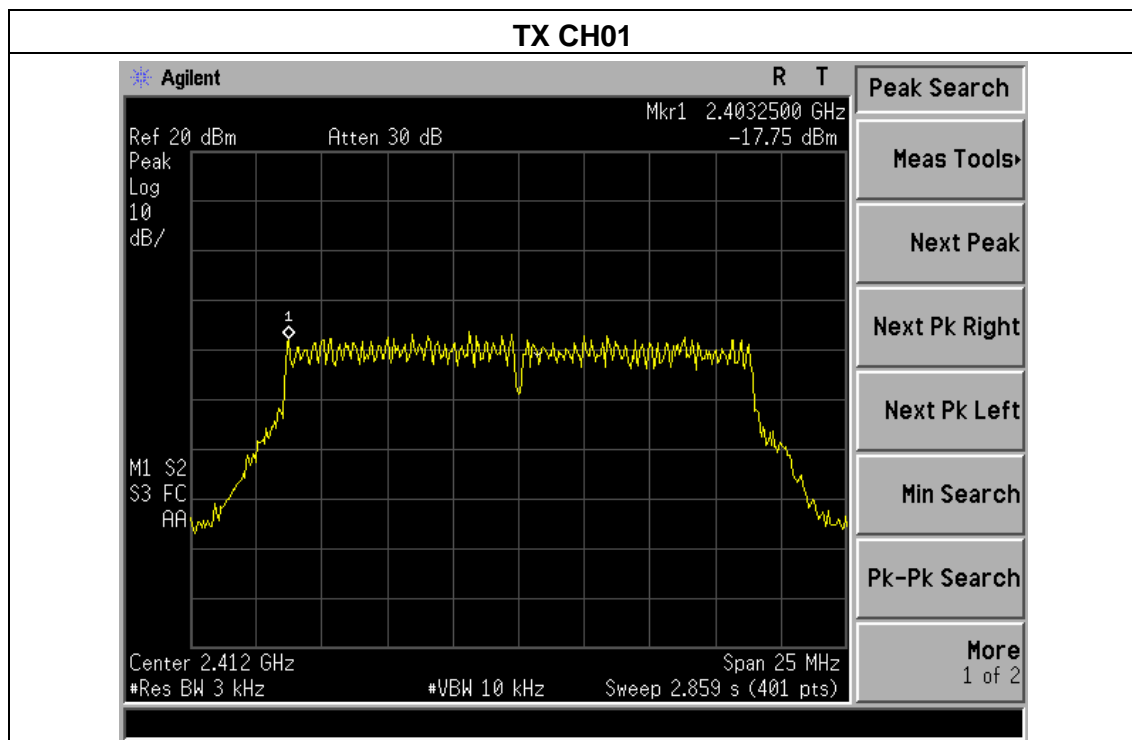

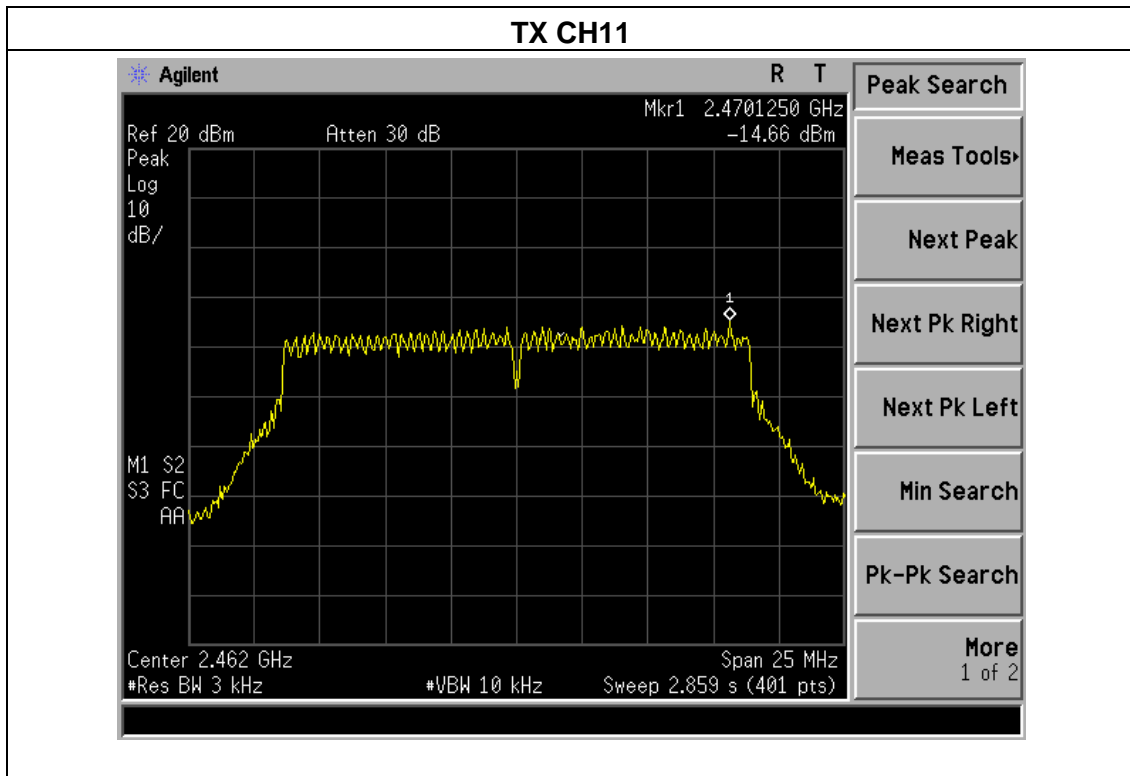
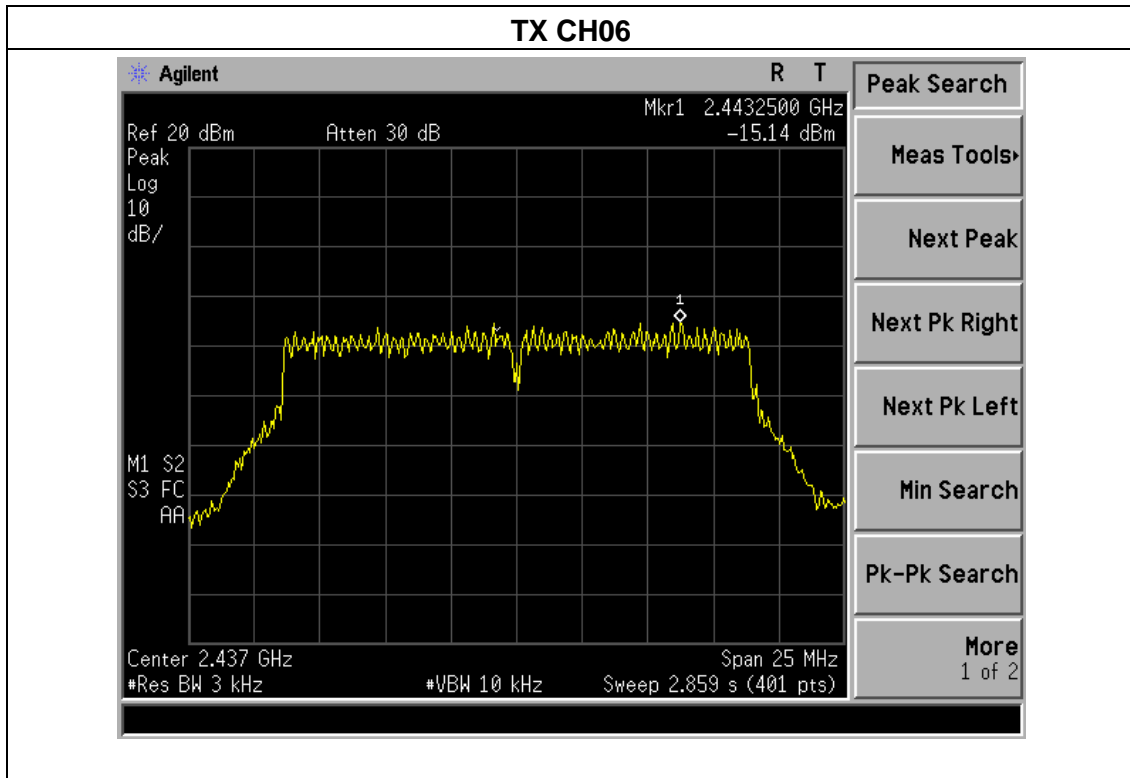



5. BANDWIDTH TEST

5.1 APPLIED PROCEDURES / LIMIT

FCC Part15 (15.247) , Subpart C				
Section	Test Item	Limit	Frequency Range (MHz)	Result
15.247(a)(2)	Bandwidth	$\geq 500\text{KHz}$ (6dB bandwidth)	2400-2483.5	PASS

5.1.1 TEST PROCEDURE

1. Set RBW = 100 kHz.
2. Set the video bandwidth (VBW) $\geq 3 \times$ RBW.
3. Detector = Peak.
4. Trace mode = max hold.
5. Sweep = auto couple.
6. Allow the trace to stabilize.
7. Measure the maximum width of the emission that is constrained by the frequencies associated with the two outermost amplitude points (upper and lower frequencies) that are attenuated by 6 dB relative to the maximum level measured in the fundamental emission.

5.1.2 DEVIATION FROM STANDARD

No deviation.

5.1.3 TEST SETUP



5.1.4 EUT OPERATION CONDITIONS

The EUT tested system was configured as the statements of 2.4 Unless otherwise a special operating condition is specified in the follows during the testing.



5.1.5 TEST RESULTS

EUT :	Set Top Box	Model Name :	I68
Temperature :	25°C	Relative Humidity :	54%
Pressure :	1012 hPa	Test Voltage :	DC 5V from adapter
Test Mode :	TX b Mode /CH01, CH06, CH11		

Channel	Frequency (MHz)	6dB bandwidth (MHz)	Limit (kHz)	Result
Low	2412	8.131	500	Pass
Middle	2437	8.122	500	Pass
High	2462	7.675	500	Pass

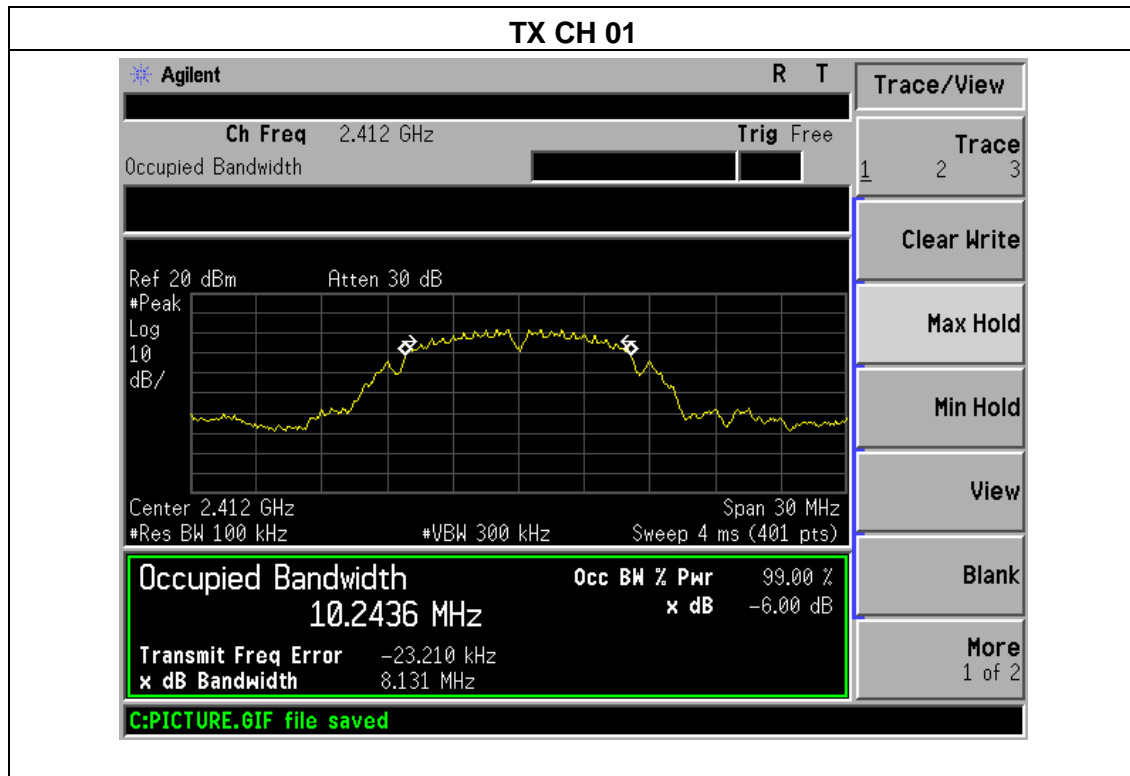

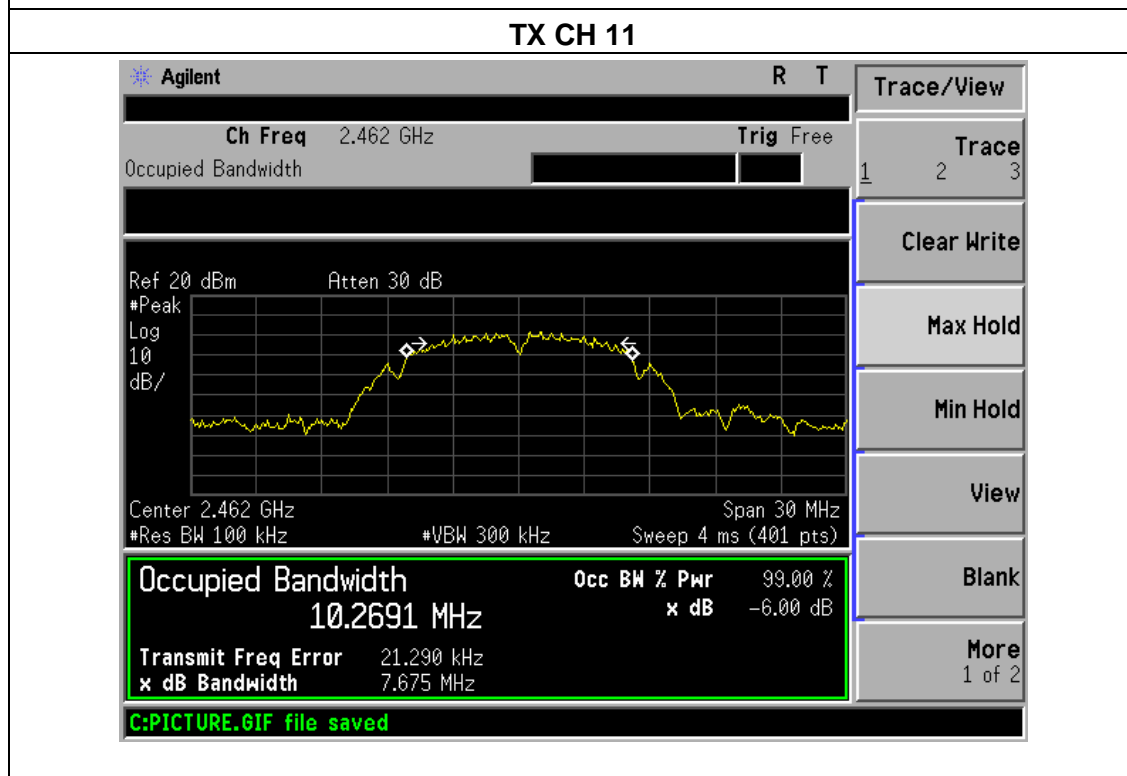
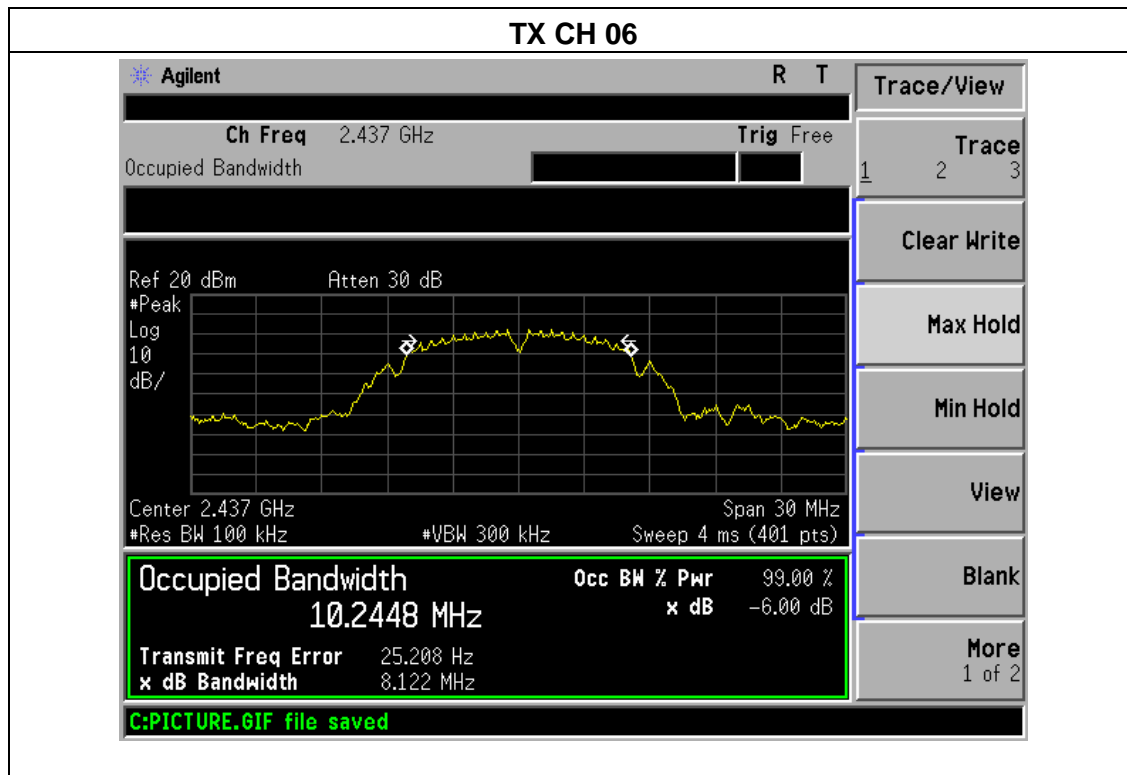



EUT :	Set Top Box	Model Name :	I68
Temperature :	25°C	Relative Humidity :	54%
Pressure :	1012 hPa	Test Voltage :	DC 5V from adapter
Test Mode :	TX g Mode /CH01, CH06, CH11		

Channel	Frequency (MHz)	6dB bandwidth (MHz)	Limit (kHz)	Result
Low	2412	16.462	500	Pass
Middle	2437	16.443	500	Pass
High	2462	16.417	500	Pass

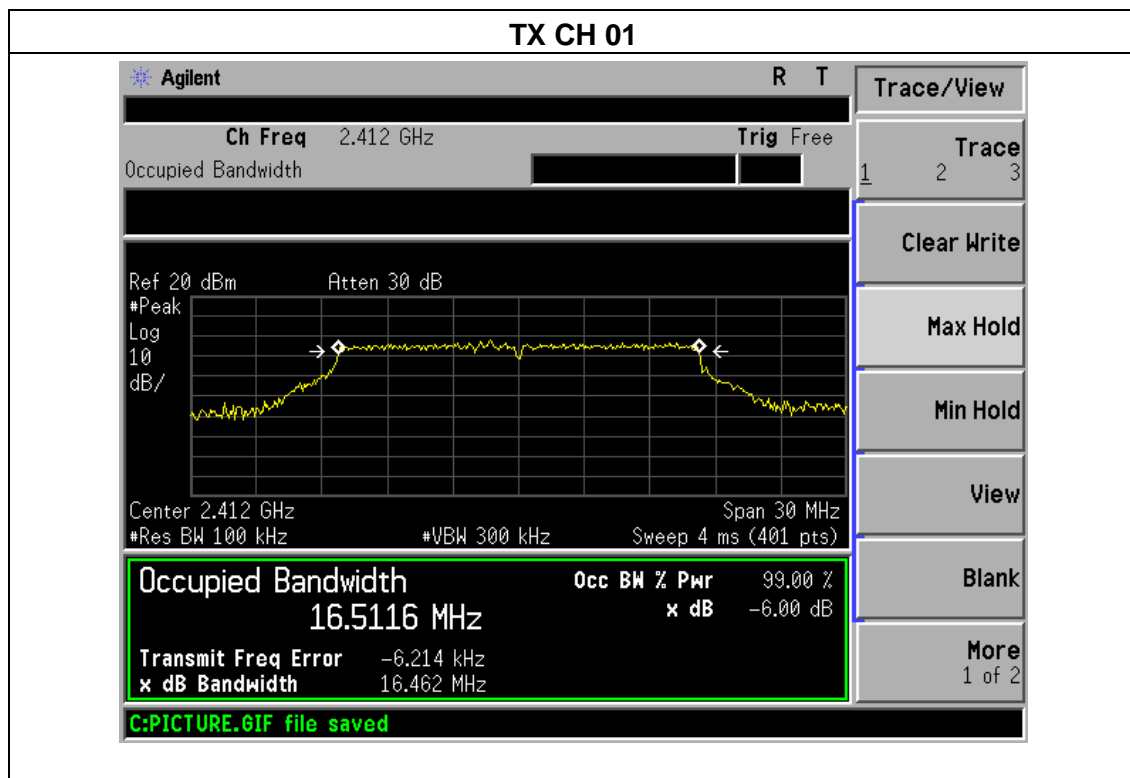

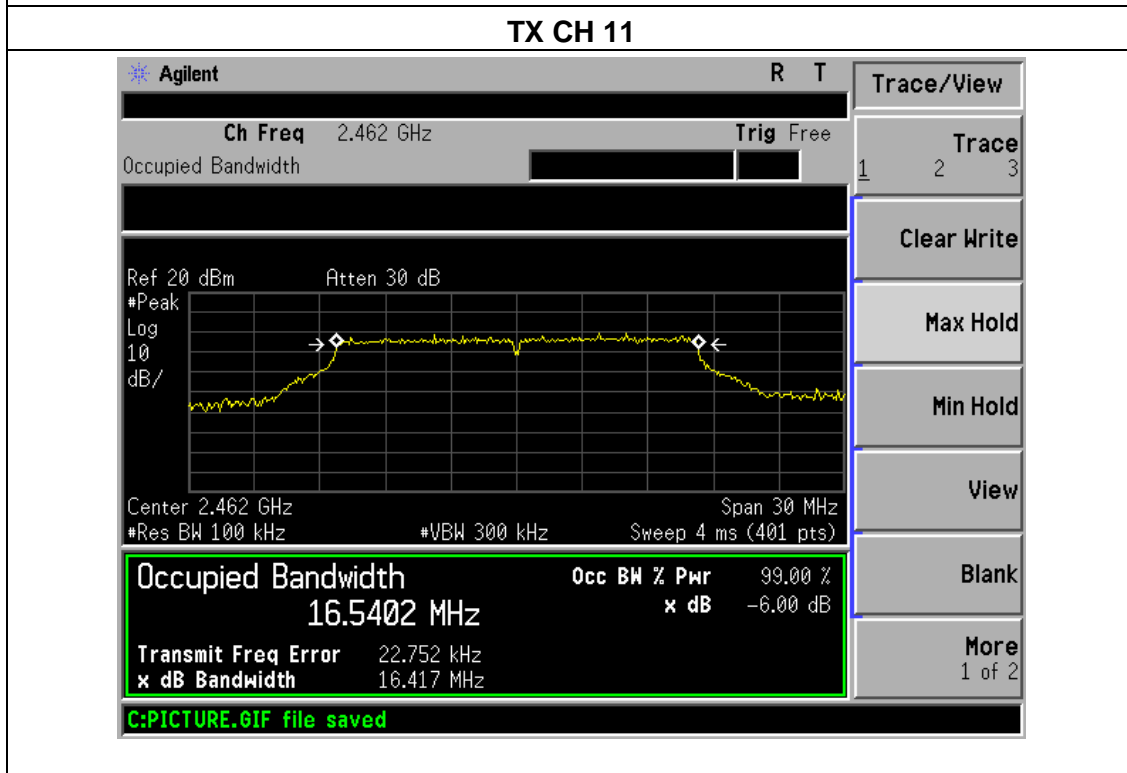
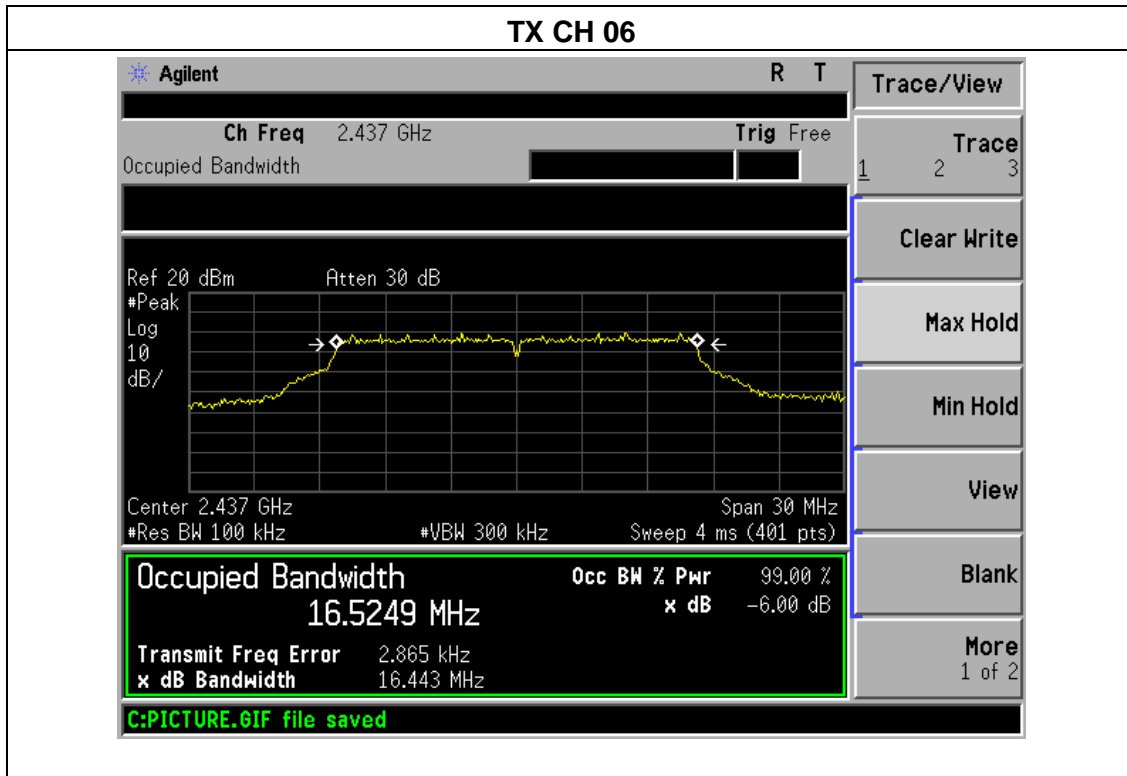



EUT :	Set Top Box	Model Name :	I68
Temperature :	25°C	Relative Humidity :	60%
Pressure :	1012 hPa	Test Voltage :	DC 5V from adapter
Test Mode :	TX n Mode(20M) /CH01, CH06, CH11		

Channel	Frequency (MHz)	6dB bandwidth (MHz)	Limit (kHz)	Result
Low	2412	17.632	500	Pass
Middle	2437	17.651	500	Pass
High	2462	17.624	500	Pass

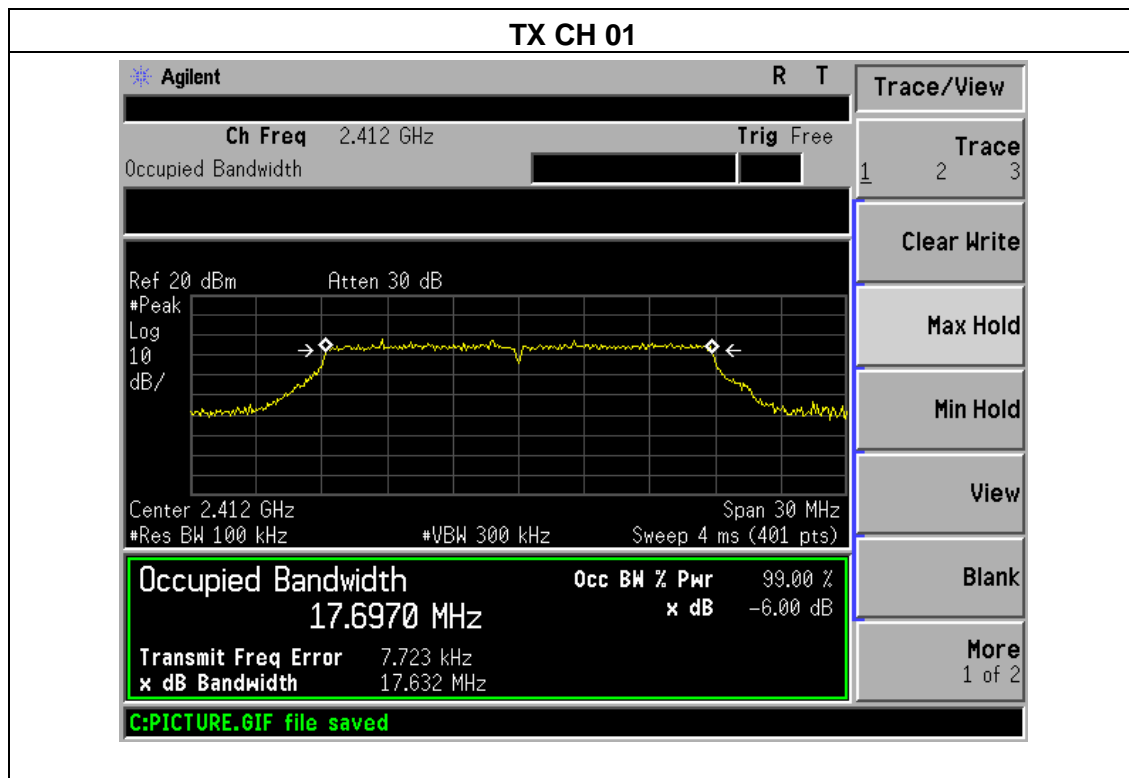

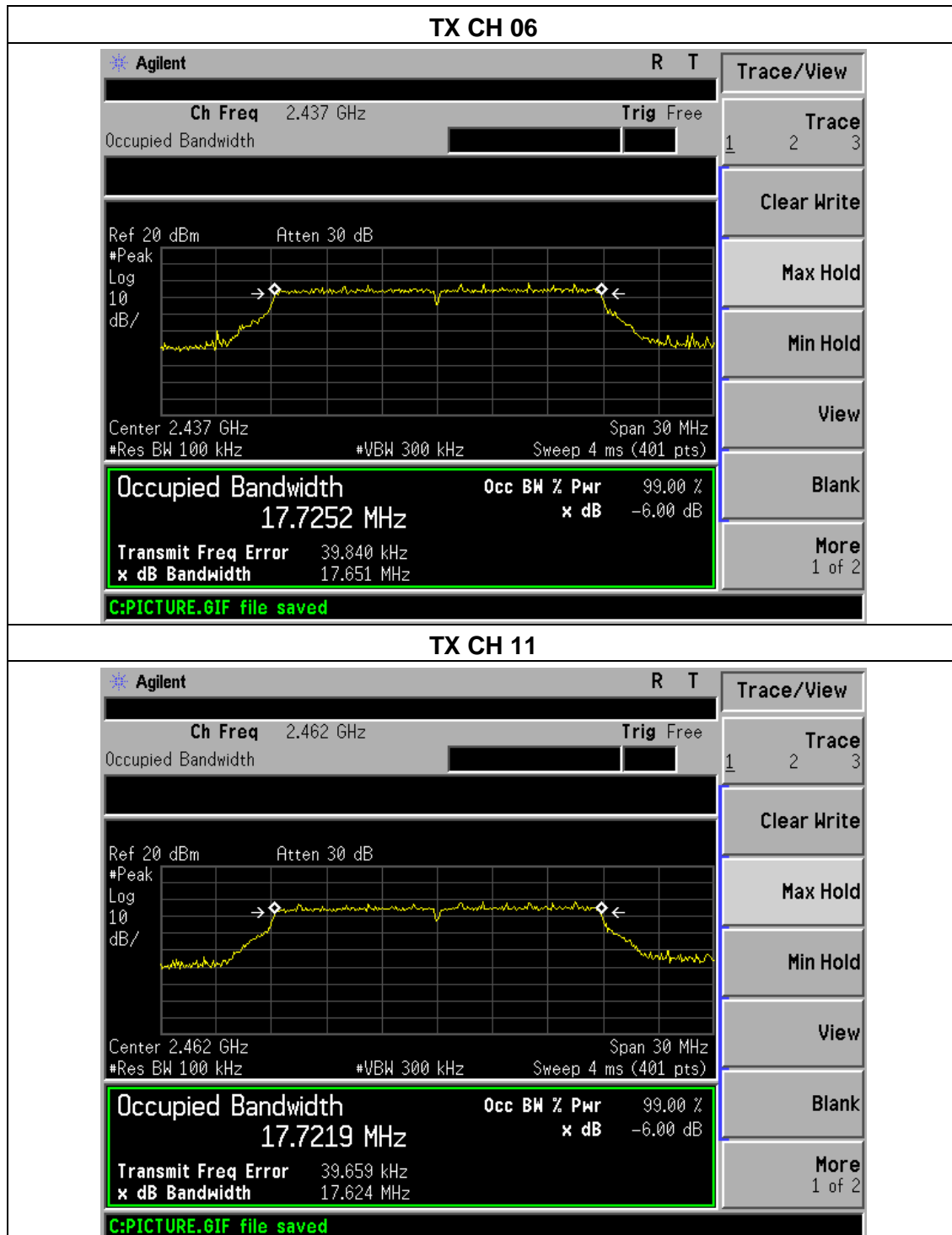



6. PEAK OUTPUT POWER TEST

6.1 APPLIED PROCEDURES / LIMIT

FCC Part15 (15.247) , Subpart C				
Section	Test Item	Limit	Frequency Range (MHz)	Result
15.247(b)(3)	Peak Output Power	1 watt or 30dBm	2400-2483.5	PASS

6.1.1 TEST PROCEDURE

- a. The EUT was directly connected to the Power meter

6.1.2 DEVIATION FROM STANDARD

No deviation.

6.1.3 TEST SETUP



6.1.4 EUT OPERATION CONDITIONS

The EUT tested system was configured as the statements of 2.4 Unless otherwise a special operating condition is specified in the follows during the testing.

**6.1.5 TEST RESULTS**

EUT :	Set Top Box	Model Name :	I68
Temperature :	25°C	Relative Humidity :	54%
Pressure :	1012 hPa	Test Voltage :	DC 5V from adapter
Test Mode :	TX b/g/n(20M)		

TX 802.11b Mode				
Test Channel	Frequency	Maximum Conducted Output Power(PK)	Maximum Conducted Output Power(AV)	LIMIT
	(MHz)	(dBm)	(dBm)	dBm
CH01	2412	11.75	10.83	30
CH06	2437	11.55	10.64	30
CH11	2462	11.38	10.52	30
TX 802.11g Mode				
CH01	2412	9.86	8.84	30
CH06	2437	9.63	8.62	30
CH11	2462	9.52	8.51	30
TX 802.11n-HT20 Mode				
CH01	2412	8.79	7.75	30
CH06	2437	8.65	7.42	30
CH11	2462	8.54	7.35	30



7. 100 KHZ BANDWIDTH OF FREQUENCY BAND EDGE

APPLICABLE STANDARD

In any 100 kHz bandwidth outside the frequency band in which the spread spectrum or digitally modulated intentional radiator is operating, the radio frequency power that is produced by the intentional radiator shall be at least 20 dB below that in the 100 kHz bandwidth within the band that contains the highest level of the desired power, based on either an RF conducted or a radiated measurement, provided the transmitter demonstrates compliance with the peak conducted power limits. If the transmitter complies with the conducted power limits based on the use of RMS averaging over a time interval, as permitted under paragraph (b)(3) of this section, the attenuation required under this paragraph shall be 30 dB instead of 20 dB. Attenuation below the general limits specified in §15.209(a) is not required. In addition, radiated emissions which fall in the restricted bands, as defined in §15.205(a), must also comply with the radiated emission limits specified in §15.209(a) (see §15.205(c)).

TEST PROCEDURE

- a) Check the calibration of the measuring instrument using either an internal calibrator or a known signal from an external generator.
- b) Position the EUT without connection to measurement instrument. Turn on the EUT and connect its antenna terminal to measurement instrument via a low loss cable. Then set it to any one measured frequency within its operating range, and make sure the instrument is operated in its linear range.
- c) Set RBW to 100 kHz and VBW of spectrum analyzer to 300 kHz with a convenient frequency span including 100 kHz bandwidth from band edge.
- d) Measure the highest amplitude appearing on spectral display and set it as a reference level. Plot the graph with marking the highest point and edge frequency.
- e) Repeat above procedures until all measured frequencies were complete.
- f) The measuring distance of at 3 m shall be used for measurements at frequency up to 1GHz. For frequencies above 1GHz, any suitable measuring distance may be used.
- g) The height of the equipment or of the substitution antenna shall be 0.8 m; above 1GHz, the height was 1.5m, the height of the test antenna shall vary between 1 m to 4 m. Both horizontal and vertical polarizations of the antenna are set to make the measurement.
- h) The height of the equipment or of the substitution antenna shall be 0.8 m; above 1GHz, the height was 1.5m, the height of the test antenna shall vary between 1 m to 4 m. Both horizontal and vertical polarizations of the antenna are set to make the measurement. The initial step in



collecting conducted emission data is a spectrum analyzer peak detector mode pre-scanning the measurement frequency range. Significant peaks are then marked and then Quasi Peak detector mode re-measured.

- i) If the Peak Mode measured value compliance with and lower than Quasi Peak Mode Limit, the EUT shall be deemed to meet QP Limits and then no additional QP Mode measurement performed.
- j) For the actual test configuration, please refer to the related Item –EUT Test Photos.

Note:

Both horizontal and vertical antenna polarities were tested and performed pretest to three orthogonal axis. The worst case emissions were reported

7.1 DEVIATION FROM STANDARD

No deviation.

7.2 TEST SETUP

Conducted Emission Test



Radiated Emission Test

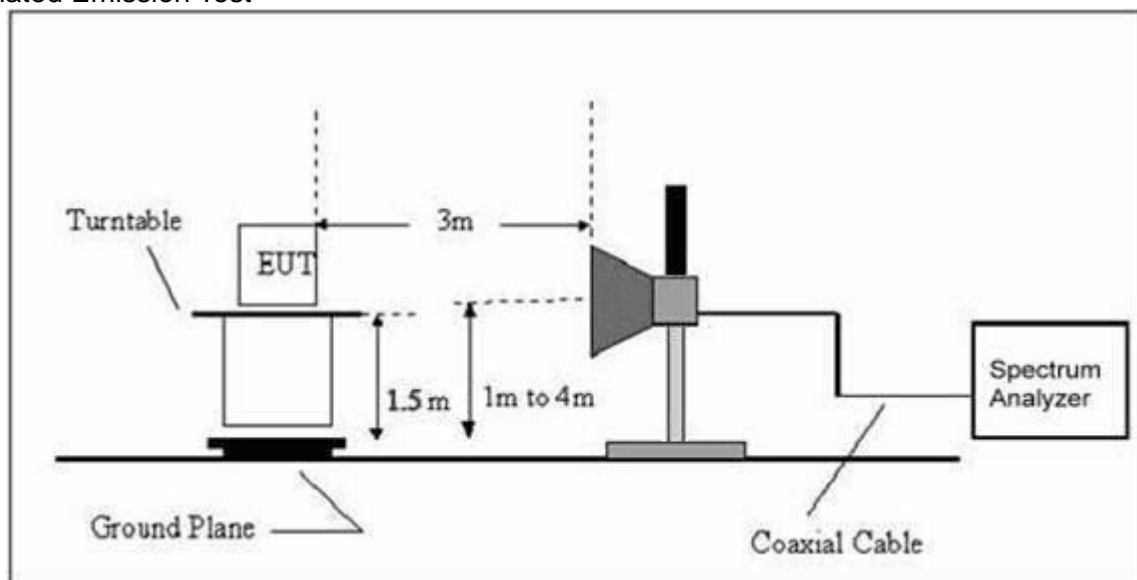

7.3 EUT OPERATION CONDITIONS

The EUT tested system was configured as the statements of 2.4 Unless otherwise a special operating condition is specified in the follows during the testing.

**7.4 TEST RESULTS**

EUT :	Set Top Box	Model Name :	I68
Temperature :	25°C	Relative Humidity :	54%
Pressure :	1012 hPa	Test Voltage :	DC 5V from adapter

Frequency Band	Delta Peak to band emission (dBc)	> Limit (dBc)	Result
802.11b mode			
Left-band	42.24	20	Pass
Right-band	43.86	20	Pass
802.11g mode			
Left-band	33.01	20	Pass
Right-band	32.63	20	Pass
802.11n-HT20 mode			
Left-band	30.41	20	Pass
Right-band	36.83	20	Pass



802.11b: Band Edge, Left Side

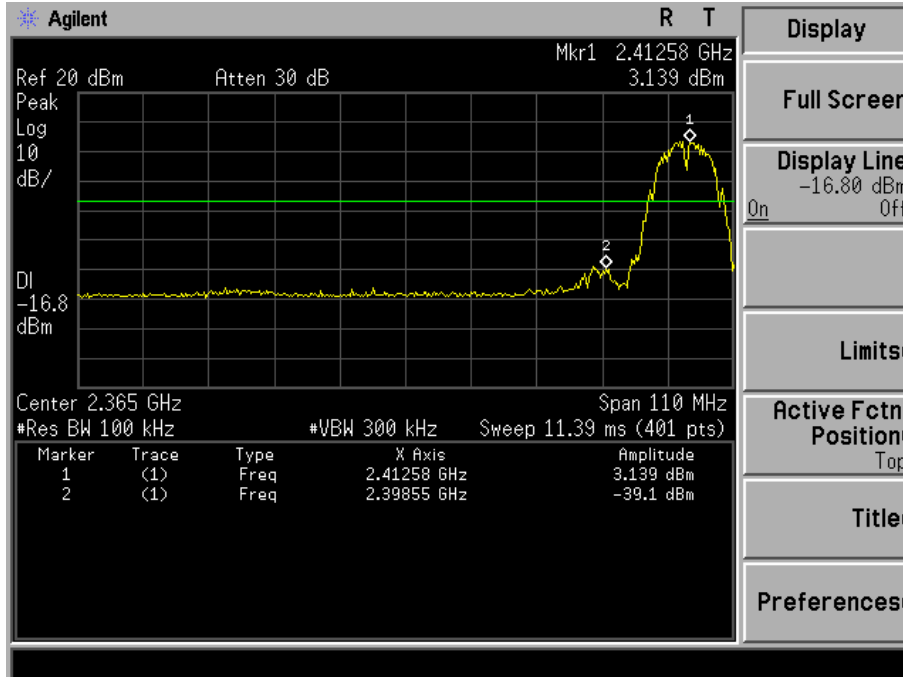

802.11b: Band Edge, Right Side

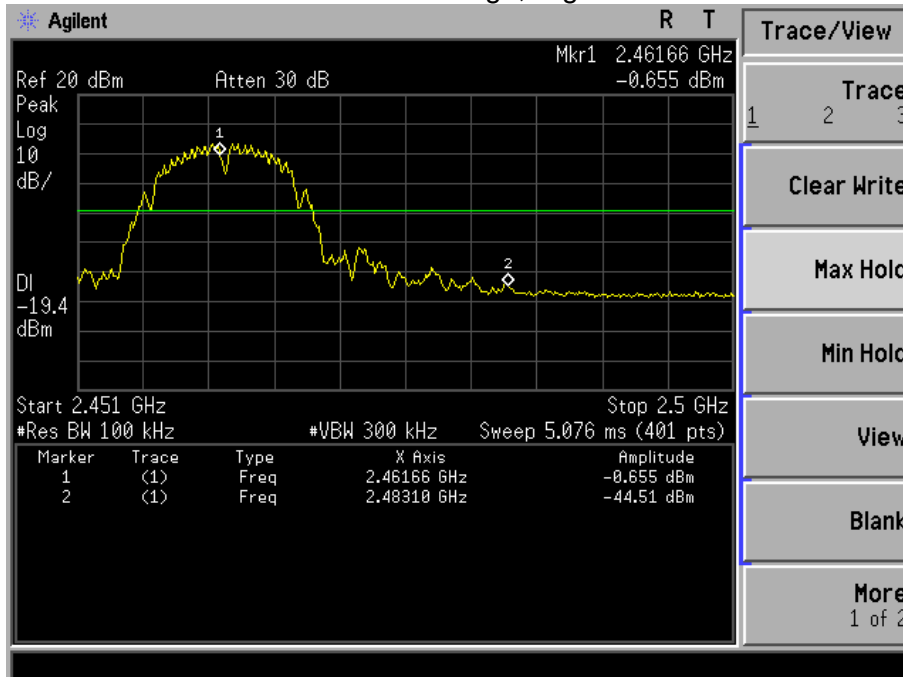



802.11g: Band Edge, Left Side

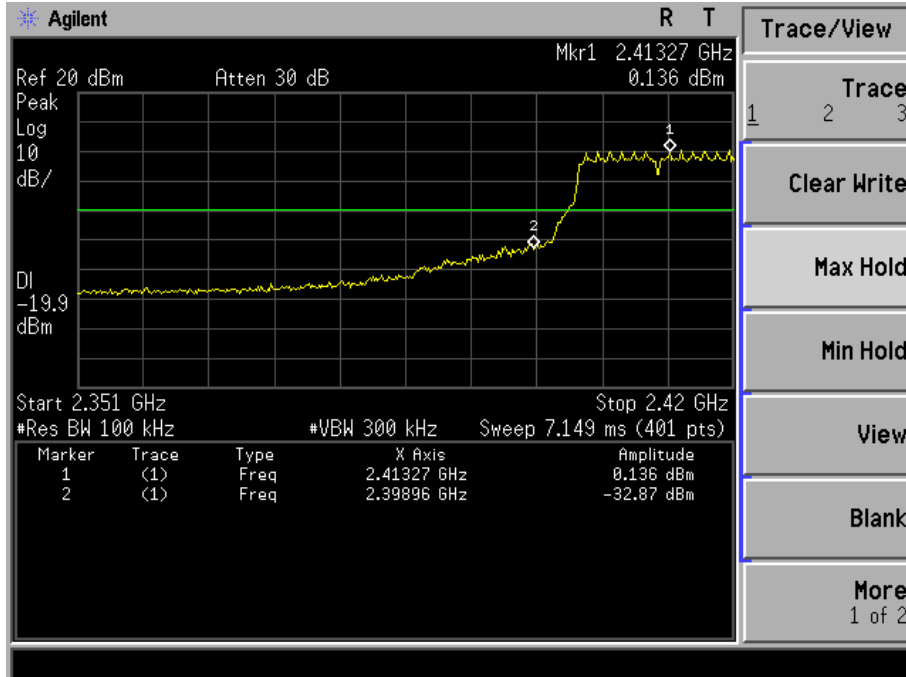

802.11g: Band Edge, Right Side

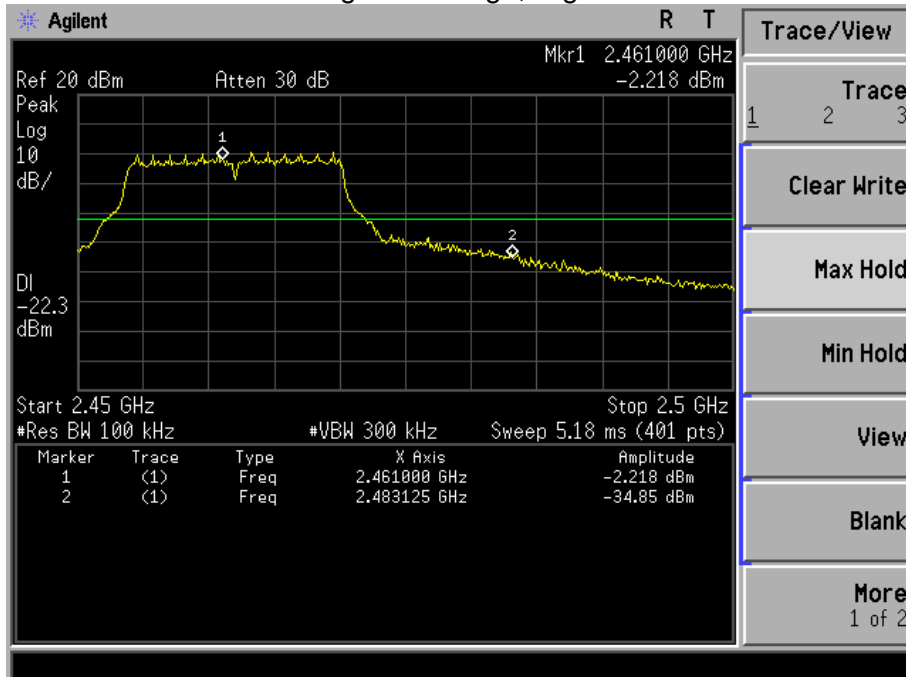



802.11n-HT20: Band Edge, Left Side

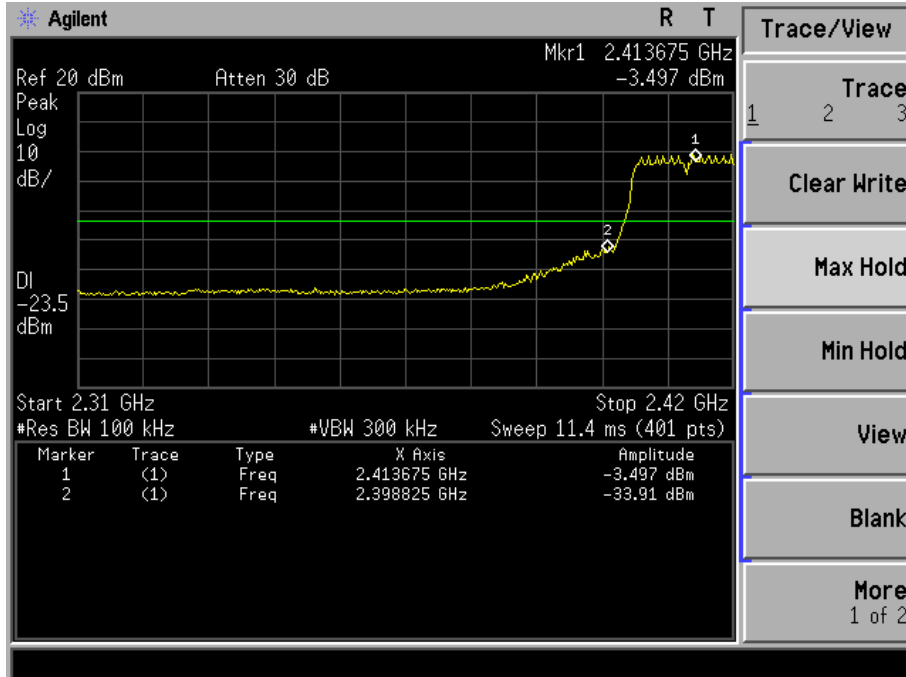

802.11n-HT20: Band Edge, Right Side

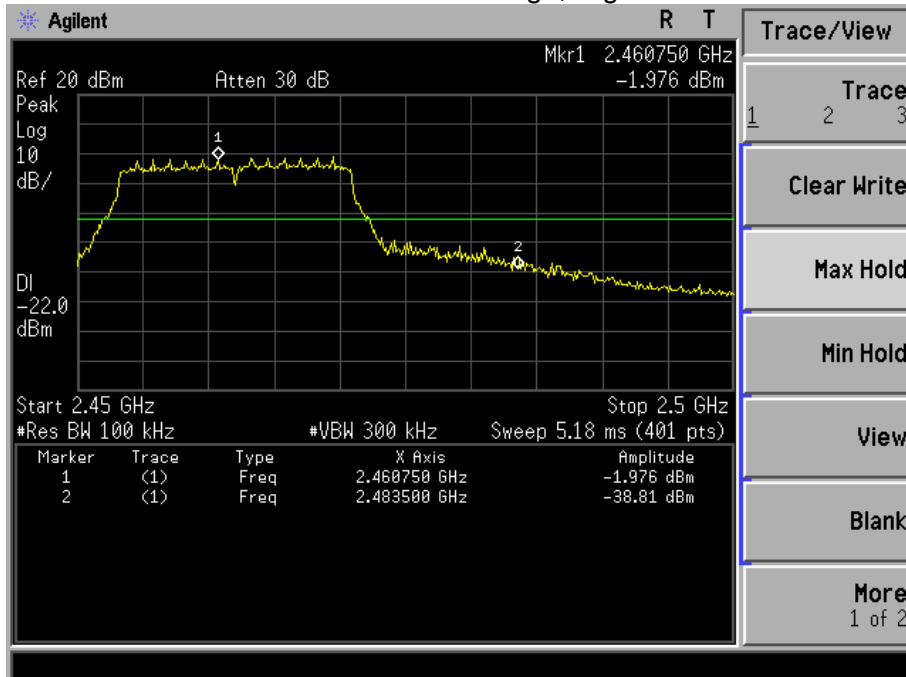



8. DUTY CYCLE OF TEST SIGNAL

8.1 STANDARD REQUIREMENT

Pre-analysis Check: While conducting average power measurement, duty cycle of each mode shall be checked to ensure its duty cycle in order to compensate for the loss due to insufficient ratio of duty cycle.

All duty cycle is pre-scanned, and result as obtained below shows only the most representative ones where duty cycle is conducted as the given transmission with given virtual operation that expresses the percentage.

8.2 FORMULA:

Duty Cycle = $T_{on} / (T_{on} + T_{off})$

Measurement Procedure:

1. Set span = Zero
2. RBW = 8MHz
3. VBW = 8MHz,
4. Detector = Peak

Duty Cycle:

	Duty Cycle	Duty Fator (dB)
802.11b	1	0
802.11g	1	0
802.11n(HT20)	1	0



9. ANTENNA REQUIREMENT

9.1 STANDARD REQUIREMENT

15.203 requirement: For intentional device, according to 15.203: an intentional radiator shall be designed to ensure that no antenna other than that furnished by the responsible party shall be used with the device.

9.2 EUT ANTENNA

The EUT antenna is Integrated (FPCB) antenna. It comply with the standard requirement.

10. EUT TEST PHOTO

Conducted Measurement Photos



Radiated Measurement Photos

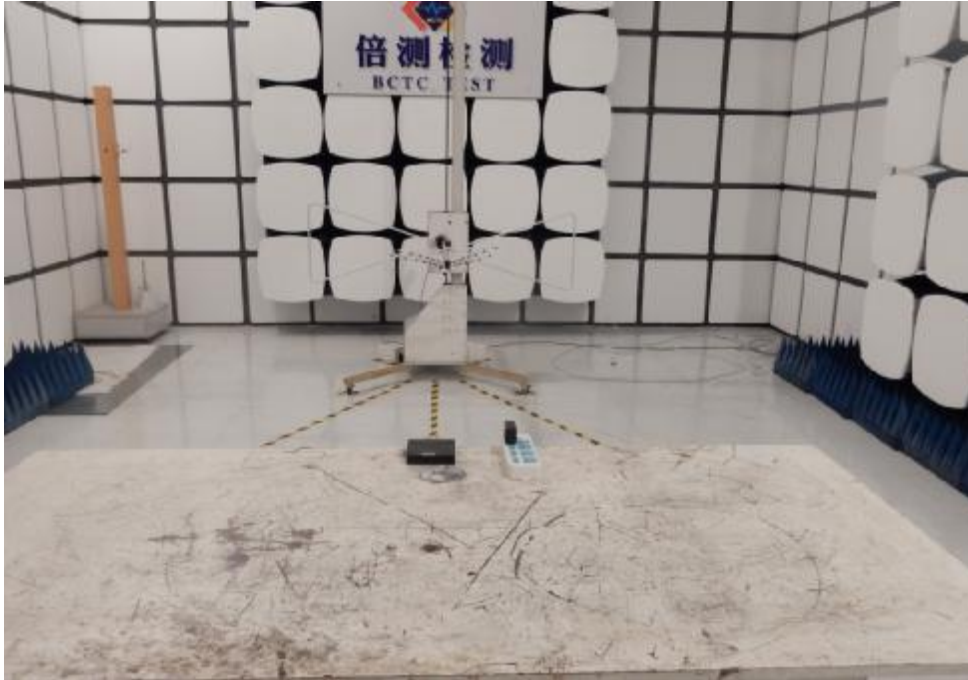

11. EUT PHOTO



***** END OF REPORT *****