

**ELECTROMAGNETIC EMISSIONS COMPLIANCE REPORT  
INTENTIONAL RADIATOR CERTIFICATION TO  
FCC PART 15 SUBPART B & C REQUIREMENT**

OF

LED Surface Mounted Luminaire

MODEL No.: TOP8232-LED-U-X-Sensor-EM, TOPA224-LED-U-X-Sensor-EM

FCC ID: 2AH36-SENSOR-EM

REPORT NO: ES160325016E

ISSUE DATE: May 3, 2016

Prepared for  
NINGBO TOP OPTOELECTRONIC TECHNOLOGY CO.,LTD  
329 NATIONALHWY SANBEI TOWN NINGBO, ZHEJIANG 315331 CHINA

Prepared by  
EMTEK (SHENZHEN) CO., LTD.  
Building 69, Majialong Industry Zone, Nanshan District, Shenzhen, Guangdong, China  
Tel: +86-755-26954280  
Fax: +86-755-26954282

**VERIFICATION OF COMPLIANCE**

Applicant:	NINGBO TOP OPTOELECTRONIC TECHNOLOGY CO.,LTD 329 NATIONALHWY SANBEI TOWN NINGBO, ZHEJIANG 315331 CHINA
Product Description:	LED Surface Mounted Luminaire
Model Number:	TOP8232-LED-U-X-Sensor-EM, TOPA224-LED-U-X-Sensor-EM(Note: "X" indicates CCT, between 2700K and 6500K, We prepared TOPA224-LED-U-5000K-Sensor-EM for test.)
File Number:	ES160325016E
Date of Test:	March 21, 2016 to April 30, 2016

**We hereby certify that:**

The above equipment was tested by EMTEK (SHENZHEN) CO., LTD. The test data, data evaluation, test procedures, and equipment configurations shown in this report were made in accordance with the procedures given in ANSI C63.10 (2013) and the energy emitted by the sample EUT tested as described in this report is in compliance with conducted and radiated emission limits of FCC Rules Part 15.249(2015).

The test results of this report relate only to the tested sample identified in this report.

Date of Test : March 21, 2016 to April 30, 2016

Prepared by :   
Joe Xia /Editor

Reviewer :   
Yaping Shen /Supervisor

Approve & Authorized Signer :   
Lisa Wang/Manager

## TABLE OF CONTENTS

<b>1. GENERAL INFORMATION.....</b>	<b>4</b>
1.1. Product Description.....	4
1.2. Related Submittal(s) / Grant (s) .....	4
1.3. Test Methodology .....	4
1.4. Special Accessories .....	4
1.5. Equipment Modifications.....	4
1.6. Test Facility.....	5
1.7. Measurement Uncertainty .....	5
<b>2. SYSTEM TEST CONFIGURATION .....</b>	<b>6</b>
2.1. EUT Configuration .....	6
2.2. EUT Exercise .....	6
2.3. Requirement for Compliance .....	6
2.4. Configuration of Tested System.....	8
2.5. Description of support units.....	8
<b>3. SUMMARY OF TEST RESULTS .....</b>	<b>9</b>
<b>4. DESCRIPTION OF TEST MODES.....</b>	<b>9</b>
<b>5. BANDWIDTH TEST.....</b>	<b>10</b>
5.1. Measurement Procedure.....	10
5.2. Measurement Equipment Used .....	10
5.3. Test Procedure.....	10
5.4. Test Results .....	11
<b>6. CONDUCTED EMISSIONS TEST .....</b>	<b>12</b>
6.1. Measurement Procedure.....	12
6.2. Test SET-UP:.....	12
6.3. Measurement Equipment Used .....	12
6.4. Conducted Measurement Result .....	12
<b>7. RADIATED EMISSION TEST .....</b>	<b>17</b>
7.1. Measurement Procedure.....	17
7.2. Measurement Equipment Used: .....	17
7.3. Test SET-UP.....	18
7.4. Radiated Measurement Result .....	18
<b>8. BAND EDGES MEASUREMENT.....</b>	<b>26</b>
8.1. Standard Applicable .....	26
8.2. Measurement Procedure.....	26
8.3. Measurement Equipment .....	26
8.4. Test Setup.....	26
8.5. Test Results .....	26
<b>9. ANTENNA APPLICATION.....</b>	<b>31</b>
9.1. Standard Applicable .....	31
9.2. Antenna Construction .....	31

## **1. GENERAL INFORMATION**

### **1.1. Product Description**

The EUT is a short range, lower power, Details of technical specification, refers to the description in follows:

- a. Operating frequency: 5772.0MHz
- b. Number of Channel: 1
- c. Antenna Designation: Integral antenna
- d. Modulation: Continuous Wave
- e. Antenna Gain: 0dbi
- f. Power Supply: 120-277V/AC, 50/60Hz

### **1.2. Related Submittal(s) / Grant (s)**

This submittal(s) (test report) is intended for FCC ID: 2AH36-SENSOR-EM filing to comply with Section 15.249 of the FCC Part 15 Subpart C Rules.

### **1.3. Test Methodology**

Both conducted and radiated testing were performed according to the procedures in ANSI C63.10 -2013. Radiated testing was performed at an antenna to EUT distance 3 meters.

### **1.4. Special Accessories**

Not available for this EUT intended for grant.

### **1.5. Equipment Modifications**

Not available for this EUT intended for grant.

## 1.6. Test Facility

Site Description	
EMC Lab.	<p>: Accredited by CNAS, 2013.10.29 The certificate is valid until 2016.10.29 The Laboratory has been assessed and proved to be in compliance with CNAS-CL01:2006(identical to ISO/IEC17025:2005) The Certificate Registration Number is L2291.</p> <p>Accredited by TUV Rheinland Shenzhen 2010.5.25 The Laboratory has been assessed according to the requirements ISO/IEC 17025.</p> <p>Accredited by FCC, April 17, 2013 The Certificate Registration Number is 406365.</p> <p>Accredited by Industry Canada, November 29, 2012 The Certificate Registration Number is 46405-4480.</p>
Name of Firm	: EMTEK (SHENZHEN) CO., LTD
Site Location	: Bldg 69, Majialong Industry Zone, Nanshan District, Shenzhen, Guangdong, China

## 1.7. Measurement Uncertainty

Conducted Emission Uncertainty	: 2.96dB(9k~150kHz Conduction 1#) 2.74dB(150k-30MHz Conduction 1#)
Radiated Emission Uncertainty (3m Chamber)	: 3.78dB (30M~1GHz Polarize: H) 4.27dB (30M~1GHz Polarize: V) 4.46dB (1~6GHz) 4.96dB (6~40GHz)

## 2. SYSTEM TEST CONFIGURATION

### 2.1.EUT Configuration

The EUT configuration for testing is installed on RF field strength measurement to meet the Commissions requirement and operating in a manner which intends to maximize its emission characteristics in a continuous normal application.

### 2.2.EUT Exercise

The EUT (LED Surface Mounted Luminaire) has been tested under Normal Operating and standby condition. No software used to control the EUT for staying in continuous transmitting and receiving mode for testing.

### 2.3.Requirement for Compliance

#### 2.3.1.Conducted Emissions

According to §15.107, For a Class A digital device that is designed to be connected to the public utility (AC) power line, the radio frequency voltage that is conducted back onto the AC power line on any frequency or frequencies within the band 150 kHz to 30 MHz shall not exceed the limits in the following table, as measured using a 50  $\mu$ H/50 ohms LISN.Compliance with the provisions of this paragraph shall be based on the measurement of the radio frequency voltage between each power line and ground at the power terminal. The lower limit applies at the boundary between the frequency ranges.

<b>Frequency(MHz)</b>	<b>Quasi-peak</b>	<b>Average</b>
0.15-0.5	79	66
0.5-30.0	73	60
Note: 1. The lower limit shall apply at the transition frequencies.		

### 2.3.2. Radiated Emissions

(a) FCC Part 15, Subpart C Section 15.109 The field strength of radiated emissions from a Class A digital device, as determined at a distance of 10 meters, shall not exceed the following:

Frequency (MHz)	Field strength $\mu\text{V/m}$	Distance(m)	Field strength at 3m $\text{dB}\mu\text{V/m}$
30-88	90	10	49.5
88-216	150	10	54.0
216-960	210	10	56.9
Above 960	300	10	60.0

Remark:  
1. Emission level in  $\text{dB}\mu\text{V/m} = 20 \log(\mu\text{V/m})$   
2. Measurement was performed at an antenna to the closed point of EUT distance of meters.

(b) FCC Part 15, Section 15.35(b) limit of radiated emission for frequency above 1000MHz

Frequency(MHz)	$\text{dB}\mu\text{V/m(at 3m)}$	
	PEAK	AVERAGE
Above 1000	74.0	54.0

(c) FCC Part 15, Subpart C Section 15.249(a). The field strength of emissions from intentional radiators operated within these frequency bands shall comply with the following:

Frequency(MHz)	Filed Strength of Fundamental(at 3m)		Filed Strength of Harmonics (at 3m)	
	PEAK	AVERAGE	PEAK	AVERAGE
902-928	114.0	94.0	74.0	54.0
2400-2483.5	114.0	94.0	74.0	54.0
5725-5875	114.0	94.0	74.0	54.0
24000-24250	128.0	108.0	88.0	68.0

(d) Band edge

Emission radiated outside of the specified frequency bands, except for harmonics, shall be attenuated by at least 50dB below the level of the fundamental or to the general radiated emission limits in section 15.209, whichever is the lesser attenuation.

Frequency Range(MHz)	Limit( $\text{dB}\mu\text{V/m}$ )	
	Peak	AV
902-928	74.0	54.0
2400-2483.5		
5725-5850		
24000-24250		

### 2.3.3. Antenna Requirement

For intentional device, according to §15.203, an intentional radiator shall be designed to ensure that no antenna other than that furnished by the responsible party shall be used with the device.

## 2.4.Configuration of Tested System

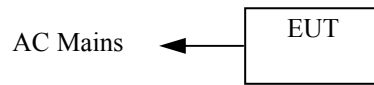

## 2.5.Description of support units

The EUT has been tested as an independent unit together with other necessary accessories or support units. The following support units or accessories were used to form a representative test configuration during the tests.

Item	Equipment	Mfr/Brand	Model/Type No.	FCC ID	Series No.	Note
1.	N/A	N/A	N/A	N/A	N/A	N/A

Note: Unless otherwise denoted as EUT in 『Remark』 column , device(s) used in tested system is a support equipment.



### 3. SUMMARY OF TEST RESULTS

FCC Rules	Description Of Test	Result
§ 15.249(a), § 15.249(d) § 15.249(e), § 15.109	Radiated Emission	Compliant
§15.107	Conducted Emission	Compliant
§15.249	Band Edge	Compliant
§15.203	Antenna Requirement	Compliant

### 4. DESCRIPTION OF TEST MODES

Continuously operating mode

Test Mode	Frequency(MHz)
TX	5772.0
\	\

## 5. BANDWIDTH TEST

### 5.1.Measurement Procedure

The WLAN component's antenna ports(s) of the EUT are connected to the measurement instrument per an appropriate attenuator.

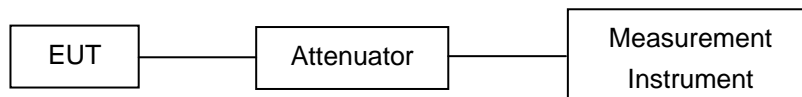

### 5.2.Measurement Equipment Used

<b>EQUIPMENT TYPE</b>	<b>MFR</b>	<b>MODEL NUMBER</b>	<b>SERIAL NUMBER</b>	<b>Last Cal.</b>	<b>Cal. Interval</b>
Signal Analyzer	Agilent	N9010A	My53470879	05/16/2015	1 Year

### 5.3.Test Procedure

The EUT was operating in controlled its channel. Printed out the test result from the spectrum by hard copy function.

The RF output of EUT was connected to the spectrum analyzer by RF cable and attenuator. The path loss was compensated to the results for each measurement.

Set to the maximum power setting and enable the EUT transmit continuously

Set RBW = 30 kHz.

Set the video bandwidth (VBW) =100 kHz.

Set Span=2 times OBW

Set Detector = Peak.

Set Trace mode = max hold.

Set Sweep = auto couple.

Allow the trace to stabilize.

Measure the maximum width of the emission that is constrained by the frequencies associated with the two outermost amplitude points (upper and lower frequencies) that are attenuated by 20 dB relative to the maximum level measured in the fundamental emission.

Measure and record the results in the test report.

### 5.4. Test Results

Temperature : 25°C                      Test Date : April 30, 2016  
 Humidity : 57 %                         Test By: King Kong

Operation Mode	Channel Frequency (MHz)	Measurement Bandwidth (KHz)	Verdict
TX	5772.0	167.8	PASS

Test Model                      Bandwidth Test  
 TX

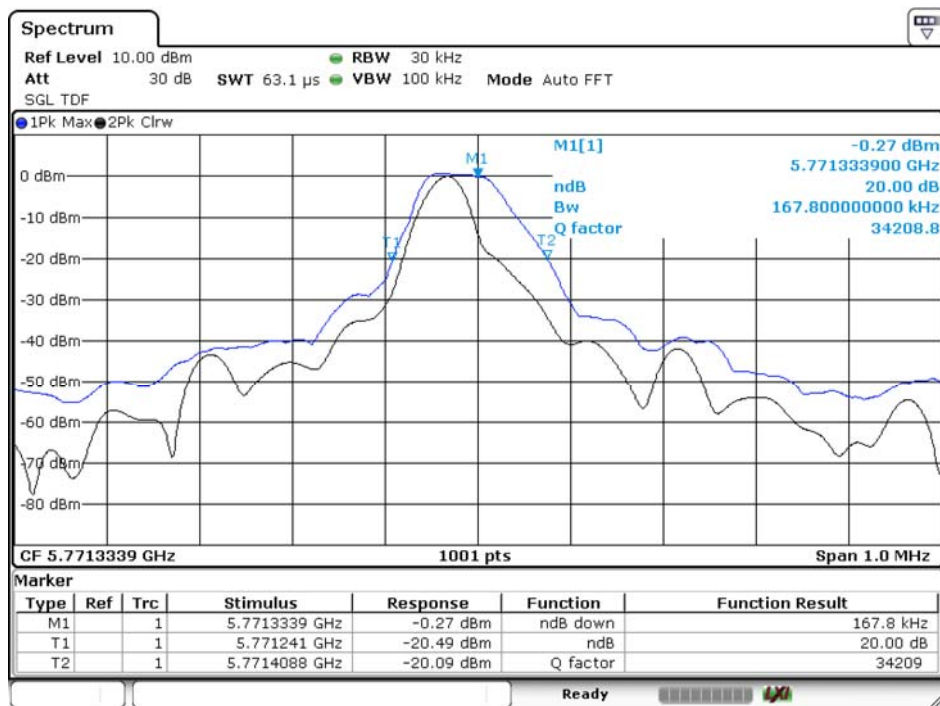

## 6. CONDUCTED EMISSIONS TEST

### 6.1.Measurement Procedure

- The EUT was placed on a table which is 0.8m above ground plane.
- Maximum procedure was performed on the three highest emissions to ensure EUT compliance.
- Repeat above procedures until all frequency measured were complete.

### 6.2.Test SET-UP:

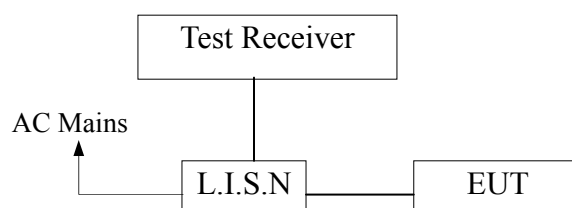

### 6.3.Measurement Equipment Used

<b>EQUIPMENT TYPE</b>	<b>MFR</b>	<b>MODEL NUMBER</b>	<b>SERIAL NUMBER</b>	<b>Last Cal.</b>	<b>Cal. Interval</b>
Test Receiver	Rohde & Schwarz	ESCS30	828985/018	05/16/2015	1 Year
L.I.S.N.	Rohde & Schwarz	ENV216	101161	05/16/2015	1 Year
50Ω Coaxial Switch	Anritsu	MP59B	M20531	05/16/2015	1 Year
Pulse Limiter	Rohde & Schwarz	ESH3-Z2	100006	05/16/2015	1 Year

### 6.4.Conducted Measurement Result

Pass.

Please refer to the following data.

Sensor mode

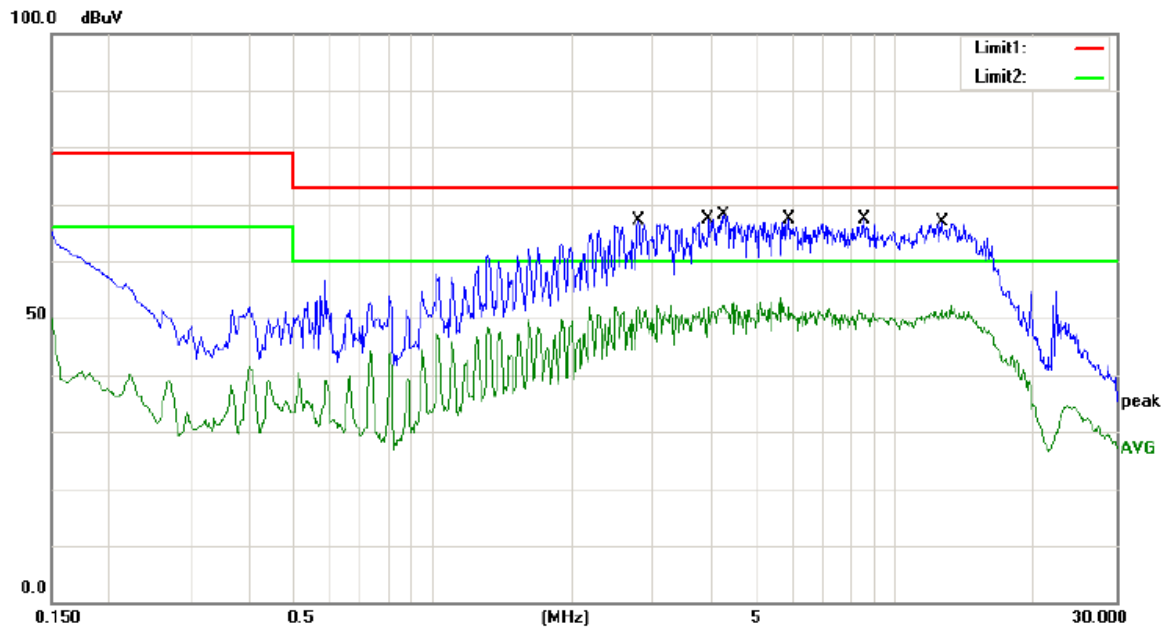

Site site #1 Phase: **N** Temperature: 22  
 Limit: (CE)FCC PART 15 class A\_QP Power: AC 277V/60Hz Humidity: 50 %  
 Mode: Sensor  
 Note:

No. Mk.	Freq. MHz	Reading Level dBuV	Correct Factor dB	Measure- ment dBuV	Limit dBuV	Over dB	Detector	Comment
1	2.7820	52.10	11.00	63.10	73.00	-9.90	QP	
2	2.7820	39.70	11.00	50.70	60.00	-9.30	AVG	
3	3.9460	52.00	11.00	63.00	73.00	-10.00	QP	
4	3.9460	40.30	11.00	51.30	60.00	-8.70	AVG	
5	4.2500	51.70	11.00	62.70	73.00	-10.30	QP	
6	4.2500	39.70	11.00	50.70	60.00	-9.30	AVG	
7 *	5.9200	56.30	11.00	67.30	73.00	-5.70	QP	
8	5.9200	40.80	11.00	51.80	60.00	-8.20	AVG	
9	8.5480	49.60	11.00	60.60	73.00	-12.40	QP	
10	8.5480	38.20	11.00	49.20	60.00	-10.80	AVG	
11	12.6320	48.30	11.00	59.30	73.00	-13.70	QP	
12	12.6320	38.40	11.00	49.40	60.00	-10.60	AVG	

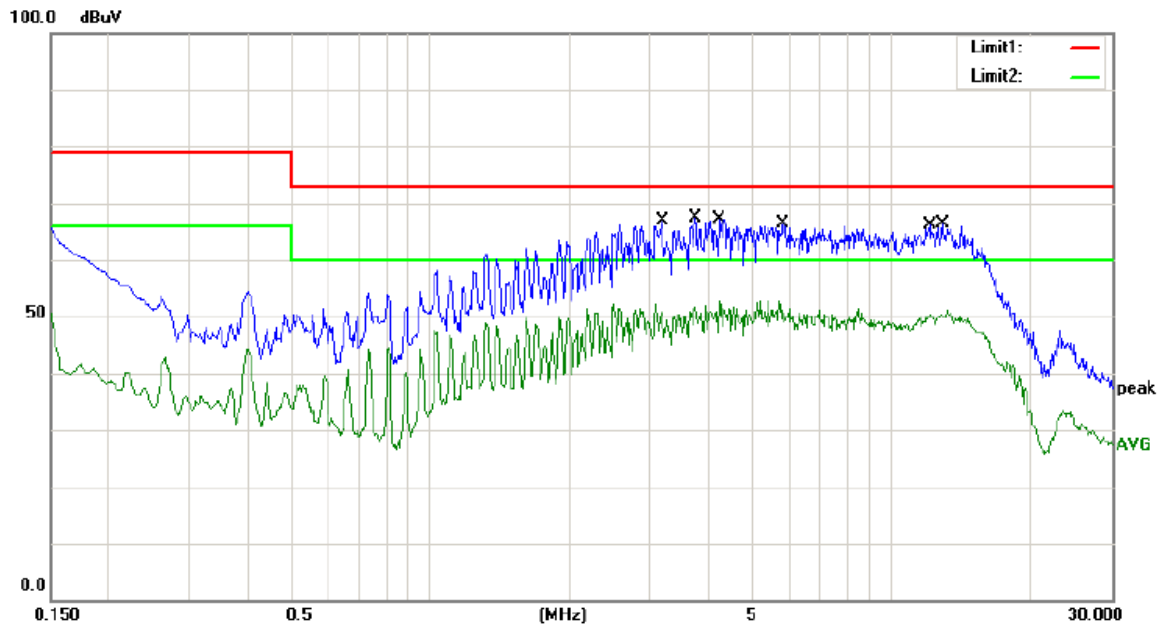

Site site #1 Phase: **L1** Temperature: 22  
 Limit: (CE)FCC PART 15 class A\_QP Power: AC 277V/60Hz Humidity: 50 %  
 Mode: Sensor  
 Note:

No.	Mk.	Freq. MHz	Reading Level dBuV	Correct Factor dB	Measure- ment dBuV	Limit dBuV	Over dB	Detector	Comment
1		3.1820	50.40	11.00	61.40	73.00	-11.60	QP	
2		3.1820	38.10	11.00	49.10	60.00	-10.90	AVG	
3		3.7580	51.80	11.00	62.80	73.00	-10.20	QP	
4		3.7580	39.10	11.00	50.10	60.00	-9.90	AVG	
5		4.2420	51.20	11.00	62.20	73.00	-10.80	QP	
6		4.2420	40.50	11.00	51.50	60.00	-8.50	AVG	
7	*	5.8080	55.30	11.00	66.30	73.00	-6.70	QP	
8		5.8080	39.30	11.00	50.30	60.00	-9.70	AVG	
9		12.0600	47.30	11.00	58.30	73.00	-14.70	QP	
10		12.0600	37.50	11.00	48.50	60.00	-11.50	AVG	
11		12.9000	47.70	11.00	58.70	73.00	-14.30	QP	
12		12.9000	37.50	11.00	48.50	60.00	-11.50	AVG	

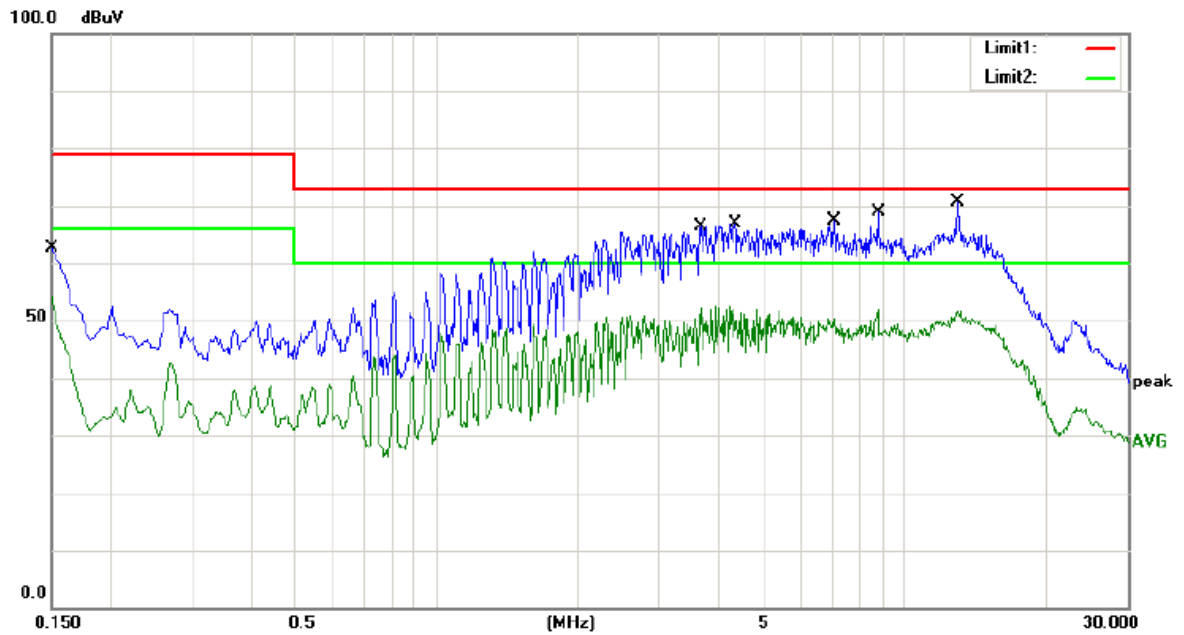

Site site #1

Phase: **L1**

Temperature: 22

Limit: (CE)FCC PART 15 class A\_QP

Power: AC 120V/60Hz

Humidity: 50 %

Mode: Sensor

Note:

No. Mk.	Freq. MHz	Reading Level dBuV	Correct Factor dB	Measure- ment dBuV	Limit dBuV	Over dB	Detector	Comment
1	0.1500	51.50	11.00	62.50	79.00	-16.50	QP	
2	0.1500	43.20	11.00	54.20	66.00	-11.80	AVG	
3	3.6620	55.40	11.00	66.40	73.00	-6.60	QP	
4	3.6620	41.00	11.00	52.00	60.00	-8.00	AVG	
5	4.3580	50.40	11.00	61.40	73.00	-11.60	QP	
6	4.3580	35.80	11.00	46.80	60.00	-13.20	AVG	
7 *	7.0920	56.20	11.00	67.20	73.00	-5.80	QP	
8	7.0920	39.30	11.00	50.30	60.00	-9.70	AVG	
9	8.8040	46.30	11.00	57.30	73.00	-15.70	QP	
10	8.8640	35.90	11.00	46.90	60.00	-13.10	AVG	
11	13.0240	48.10	11.00	59.10	73.00	-13.90	QP	
12	13.0240	38.20	11.00	49.20	60.00	-10.80	AVG	

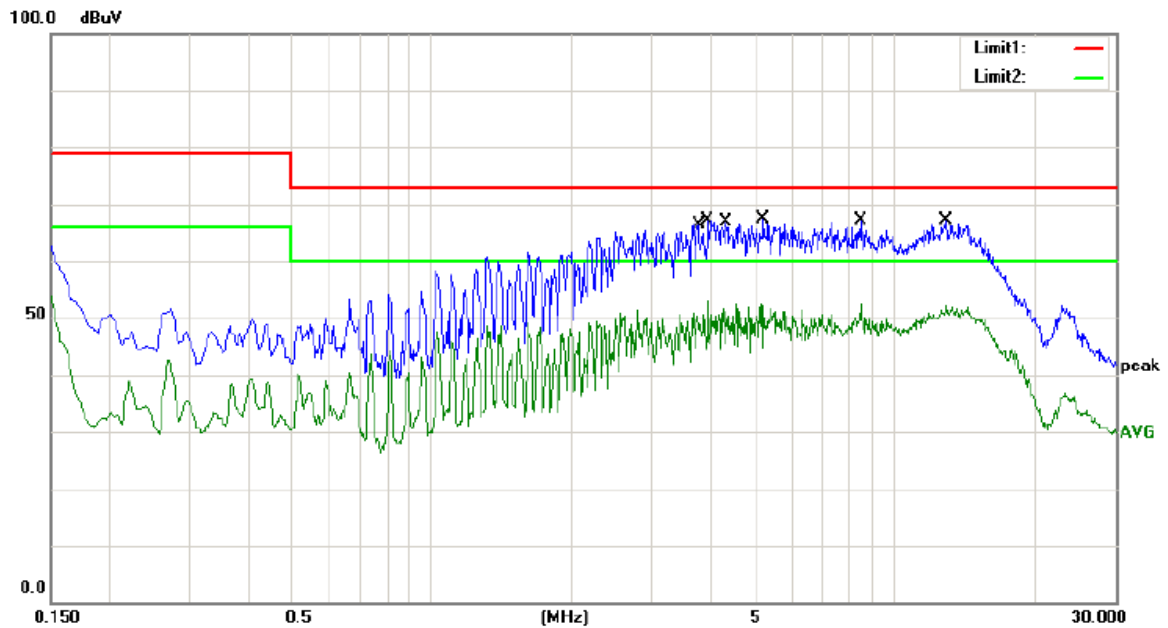

Site site #1 Phase: **N** Temperature: 22  
 Limit: (CE)FCC PART 15 class A\_QP Power: AC 120V/60Hz Humidity: 50 %  
 Mode: Sensor  
 Note:

No.	Mk.	Freq.	Reading Level	Correct Factor	Measurement	Limit	Over	Detector	Comment
		MHz	dBuV	dB	dBuV	dBuV	dB		
1		3.7660	55.30	11.00	66.30	73.00	-6.70	QP	
2		3.7660	37.00	11.00	48.00	60.00	-12.00	AVG	
3		3.9540	52.30	11.00	63.30	73.00	-9.70	QP	
4		3.9540	40.10	11.00	51.10	60.00	-8.90	AVG	
5	*	4.3300	55.80	11.00	66.80	73.00	-6.20	QP	
6		4.3300	40.20	11.00	51.20	60.00	-8.80	AVG	
7		5.2080	50.60	11.00	61.60	73.00	-11.40	QP	
8		5.2080	38.40	11.00	49.40	60.00	-10.60	AVG	
9		8.4280	50.40	11.00	61.40	73.00	-11.60	QP	
10		8.4280	37.80	11.00	48.80	60.00	-11.20	AVG	
11		12.9680	50.50	11.00	61.50	73.00	-11.50	QP	
12		12.9680	39.60	11.00	50.60	60.00	-9.40	AVG	



## 7. RADIATED EMISSION TEST

### 7.1.Measurement Procedure

- d. All measurements were made at 3 meters.
- e. The EUT was placed on the top of a rotating table 0.8 meters above the ground at a 3m meter open area test site. The table was rotated 360 degrees to determine the position of the highest radiation.
- f. The height of the equipment or of the substitution antenna shall be 0.8 m; the height of the test antenna shall vary between 1 m to 4 m. Both horizontal and vertical polarizations of the antenna are set to make the measurement.

The frequency range from 30MHz to 1000MHz was pre-scanned with a peak detector (RBW=100kHz, VBW=300kHz) and all final readings of measurement from Test Receiver are Quasi-Peak values(Quasi Peak detector used with a bandwidth of 120 kHz).

The frequency range above 1GHz the measuring instrument use RBW=1 MHz and VBW=3 MHz with Peak Detector for Peak Values, and use RBW=1 MHz and VBW=10 Hz with Peak Detector for Average Values.

### 7.2.Measurement Equipment Used:

EQUIPMENT TYPE	MFR	MODEL NUMBER	SERIAL NUMBER	Last Cal.	Cal. Interval
EMI Test Receiver	Rohde & Schwarz	ESCI	101414	May 16, 2015	1 Year
EMI Test Receiver	Rohde & Schwarz	FSV40	132.1-3008K39-10 0967-AP	May 16, 2015	1 Year
Loop Antenna	Schwarzbeck	FMZB 1519	1519-012	May 16, 2015	1 Year
Bilog Antenna	Schwarzbeck	VULB9163	660	May 16, 2015	1 Year
Horn Antenna	Schwarzbeck	BBHA 9120	1178	May 16, 2015	1 Year
Horn Antenna	Schwarzbeck	BBHA 9170	RS1307229170547	May 16, 2015	1 Year
Horn Antenna	AHS/USA	SAS-573	184	May 16, 2015	1 Year
Pre-Amplifier	LUNAR-EM	LNA30M3G-25	J10100000071	May 16, 2015	1 Year
Pre-Amplifier	Lunar EM	LNA1G18-48	J1011131010001	May 16, 2015	1 Year
Pre-Amplifier	Lunar EM	LNA18G26-40	J1012131010001	May 16, 2015	1 Year
Pre-Amplifier	Lunar EM	LNA26G40-40	J1013131028001	May 16, 2015	1 Year
Cable	H+B	NmSm-2-C15201	\	May 16, 2015	1 Year
Cable	H+B	NmNm-7-C15702	\	May 16, 2015	1 Year
Cable	H+B	NmSm-05-C15052	\	May 16, 2015	1 Year
Cable	H+B	SUCOFLEX104	MY14871/4	May 16, 2015	1 Year
Cable	H+B	BLU18A-NmSm-6500	D8501	May 16, 2015	1 Year
Cable	A.H	SAC-40G-1	414	May 16, 2015	1 Year
Cable	A.H	SAC-40G-1	413	May 16, 2015	1 Year

### 7.3. Test SET-UP

(a) Radiated Emission Test Set-Up, Frequency Below 30MHz

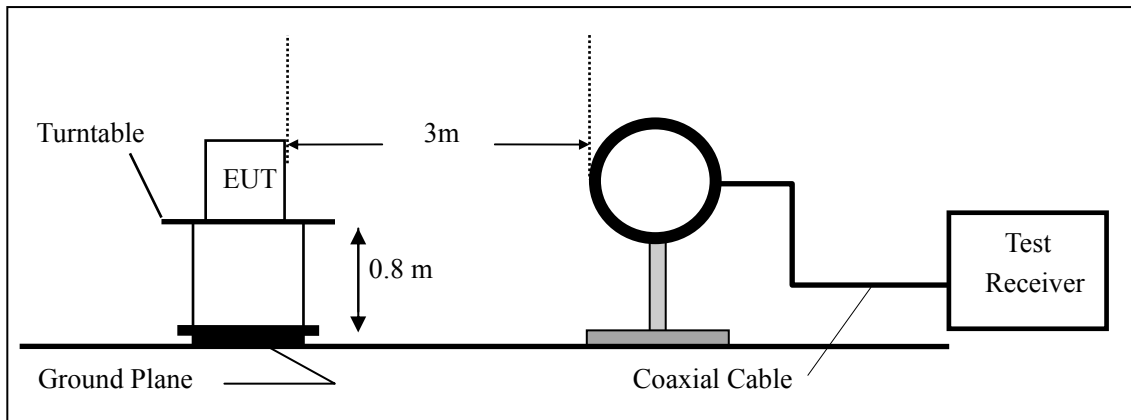

(b) Radiated Emission Test Set-Up, Frequency Below 1000MHz

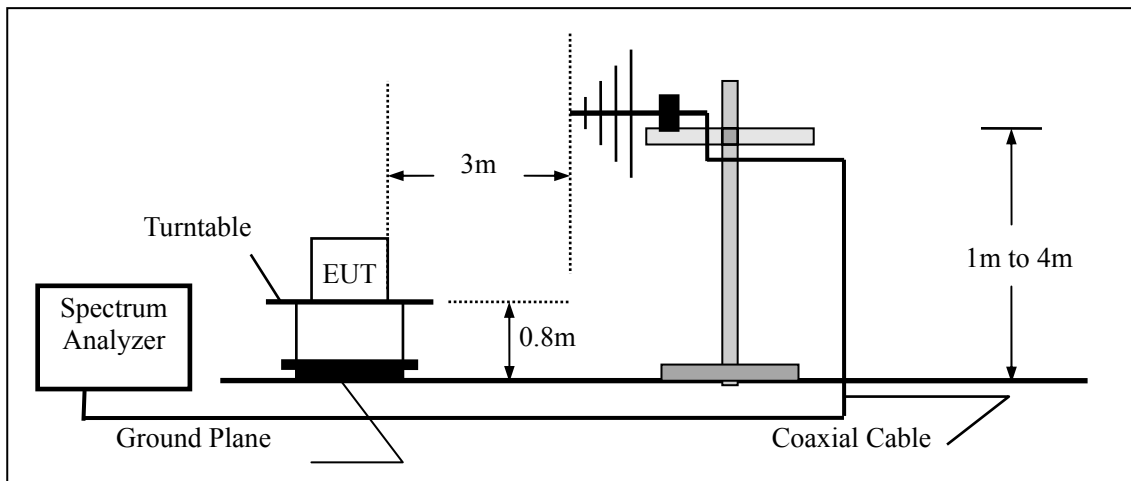

(c) Radiated Emission Test Set-Up, Frequency Above 1000MHz

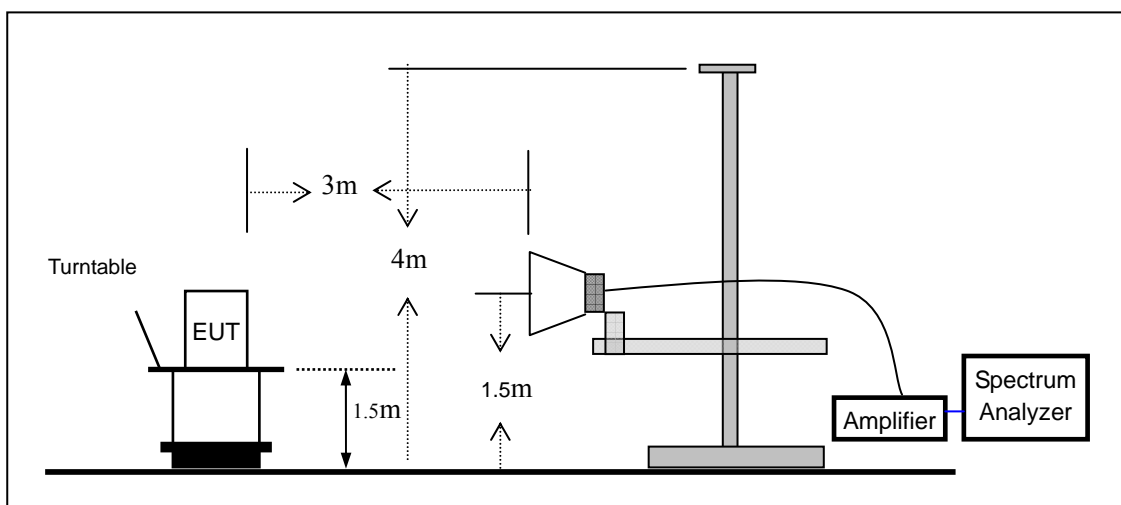

### 7.4. Radiated Measurement Result

30MHz-1GHz:

Sensor mode

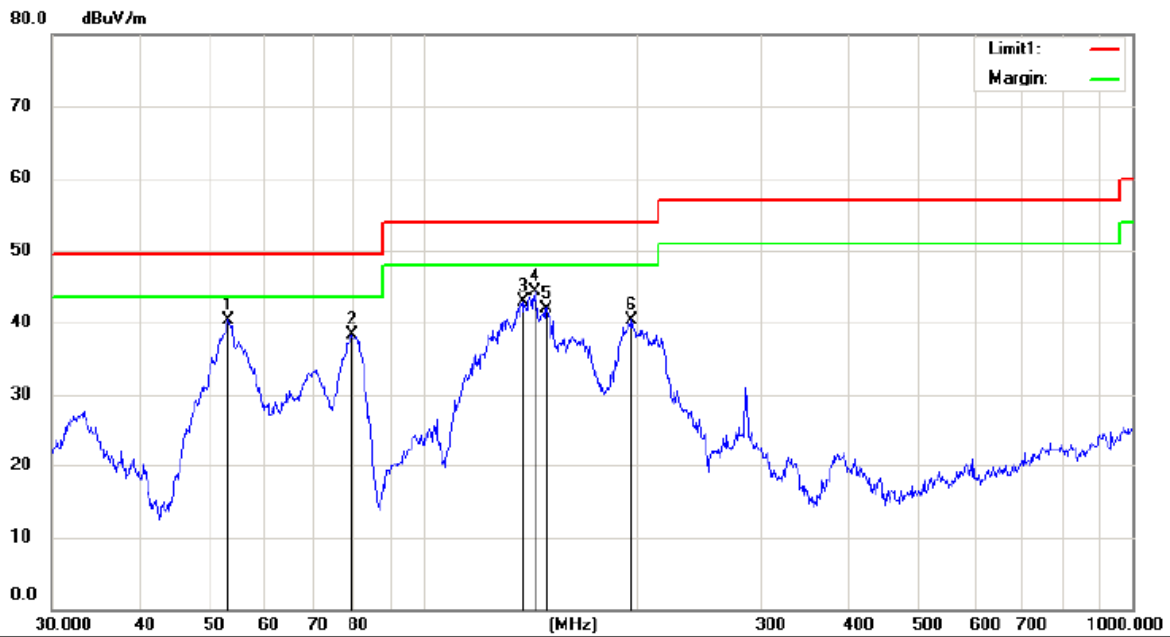

Site site #1 Polarization: **Horizontal** Temperature: 20 C  
 Limit: FCC Part15 Class A 3m Radiation Power: AC 277V/60Hz Humidity: 52 %  
 Mode:SENSOR  
 Note:

No.	Mk.	Freq. MHz	Reading Level dBuV	Correct Factor dB	Measure- ment dBuV/m	Limit dBuV/m	Over dB	Antenna Height cm	Table Degree degree	Comment
1	*	53.1313	59.96	-19.56	40.40	49.50	-9.10	QP		
2		79.5210	64.46	-26.16	38.30	49.50	-11.20	QP		
3		138.3873	68.96	-26.06	42.90	54.00	-11.10	QP		
4		143.8295	70.41	-26.11	44.30	54.00	-9.70	QP		
5		149.4857	66.90	-24.90	42.00	54.00	-12.00	QP		
6		197.2001	62.48	-22.08	40.40	54.00	-13.60	QP		



Site site #1 Polarization: **Vertical** Temperature: 20 C  
 Limit: FCC Part15 Class A 3m Radiation Power: AC 277V/60Hz Humidity: 52 %  
 Mode:SENSOR  
 Note:

No.	Mk.	Freq. MHz	Reading Level dBuV	Correct Factor dB	Measure- ment dBuV/m	Limit dBuV/m	Over dB	Detector	Antenna Height cm	Table Degree	Comment
1		54.4516	60.06	-19.66	40.40	49.50	-9.10	QP			
2	*	55.2207	60.95	-19.85	41.10	49.50	-8.40	QP			
3		56.1974	60.98	-20.18	40.80	49.50	-8.70	QP			
4		57.7962	60.69	-21.29	39.40	49.50	-10.10	QP			
5		58.6126	59.75	-21.55	38.20	49.50	-11.30	QP			
6		60.4920	58.72	-21.92	36.80	49.50	-12.70	QP			

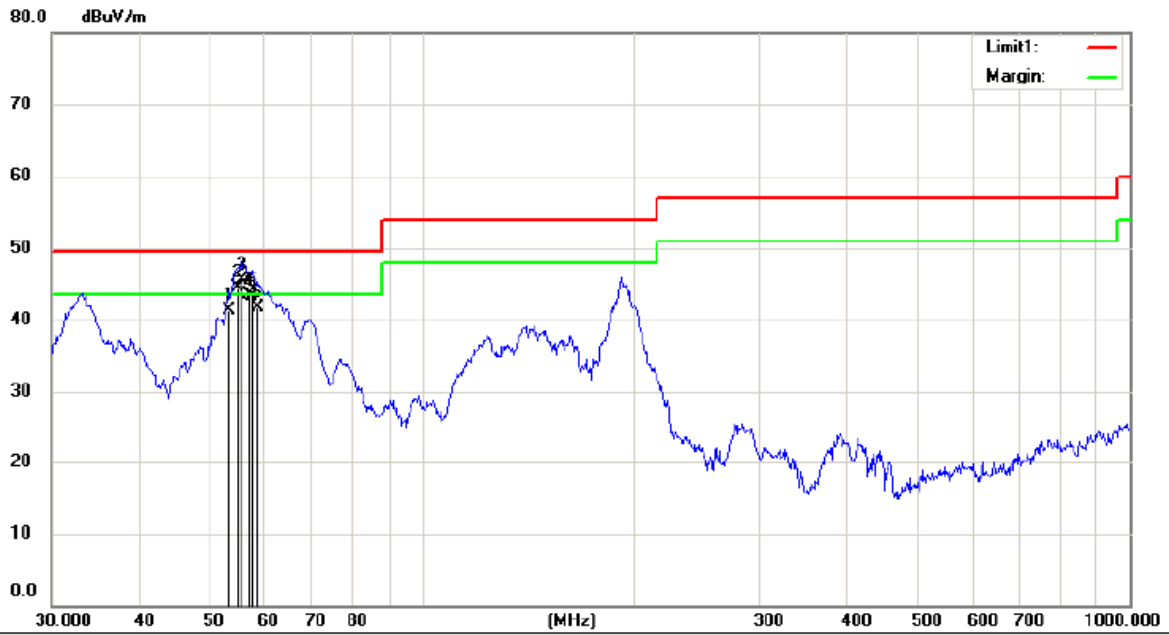

Site site #1 Polarization: **Vertical** Temperature: 20 C  
 Limit: FCC Part15 Class A 3m Radiation Power: AC 120V/60Hz Humidity: 52 %  
 Mode:SENSOR  
 Note:

No.	Mk.	Freq.	Reading Level	Correct Factor	Measurement	Limit	Over	Antenna Height	Table Degree	
		MHz	dBuV	dB	dBuV/m	dBuV/m	dB	cm	degree	Comment
1		53.5052	60.85	-19.55	41.30	49.50	-8.20			QP
2	!	54.6430	64.31	-19.71	44.60	49.50	-4.90			QP
3	*	55.8047	65.59	-19.99	45.60	49.50	-3.90			QP
4	!	56.7917	64.19	-20.59	43.60	49.50	-5.90			QP
5		57.5940	64.45	-21.15	43.30	49.50	-6.20			QP
6		58.6126	63.25	-21.55	41.70	49.50	-7.80			QP



Emergency mode

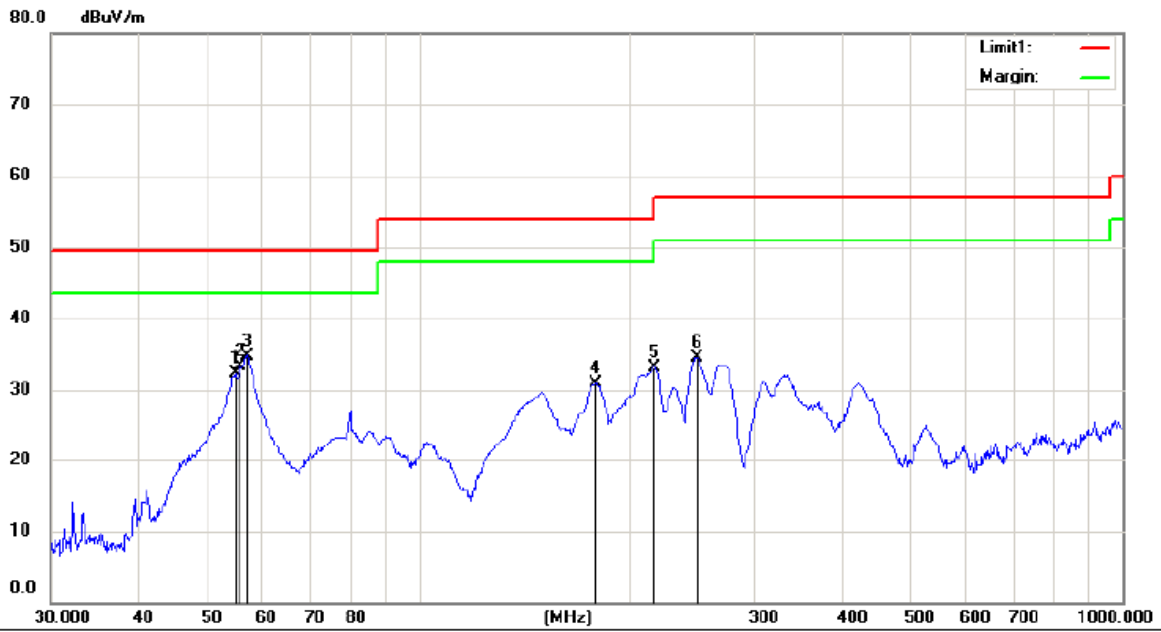

Site site #1 Polarization: **Horizontal** Temperature: 20 C  
 Limit: FCC Part15 Class A 3m Radiation Power: DC 6.4V Humidity: 52 %  
 Mode:EMERGENCY  
 Note:

No.	Mk.	Freq.	Reading Level	Correct Factor	Measurement	Limit	Over	Antenna Height	Table Degree	
		MHz	dBuV	dB	dBuV/m	dBuV/m	dB	cm	degree	Comment
1		54.8348	52.06	-19.76	32.30	49.50	-17.20	QP		
2		55.8047	53.39	-19.99	33.40	49.50	-16.10	QP		
3	*	56.9912	55.53	-20.73	34.80	49.50	-14.70	QP		
4		178.7584	55.51	-24.51	31.00	54.00	-23.00	QP		
5		216.0240	55.70	-22.50	33.20	56.90	-23.70	QP		
6		248.5520	55.90	-21.40	34.50	56.90	-22.40	QP		

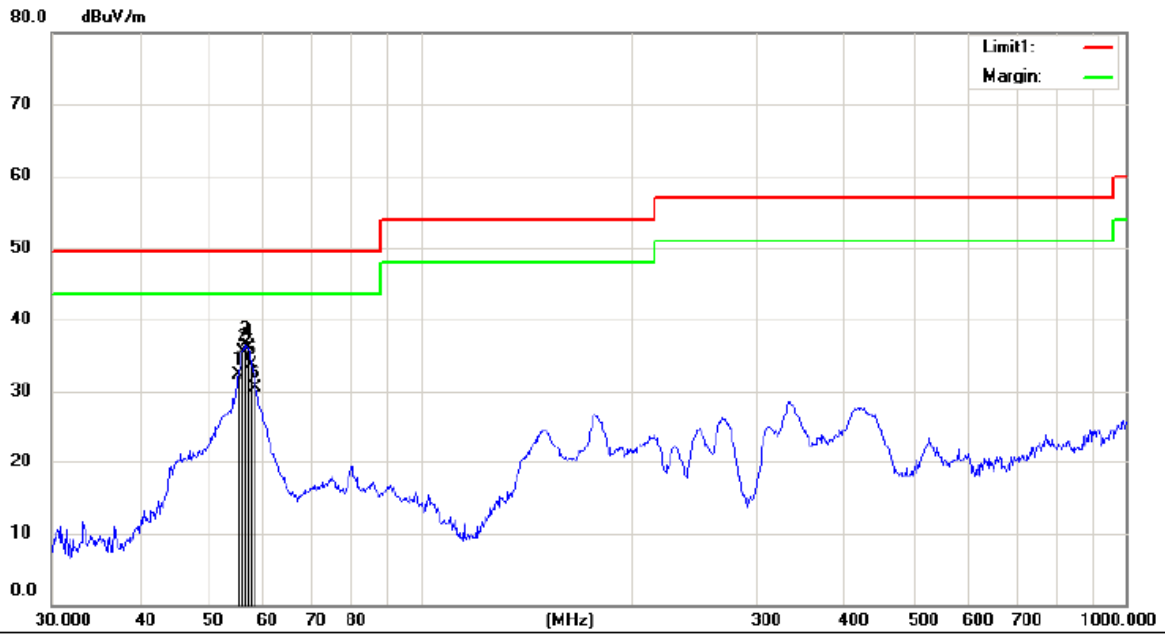

Site site #1      Polarization: *Vertical*      Temperature: 20 C  
 Limit: FCC Part15 Class A 3m Radiation      Power: DC 6.4V      Humidity: 52 %  
 Mode:EMERGENCY  
 Note:

No.	Mk.	Freq. MHz	Reading Level dBuV	Correct Factor dB	Measure- ment dBuV/m	Limit dBuV/m	Over dB	Detector	Antenna Height cm	Table Degree	Comment
1		55.2207	52.25	-19.85	32.40	49.50	-17.10	QP			
2		56.0007	55.54	-20.04	35.50	49.50	-14.00	QP			
3	*	56.5930	56.96	-20.46	36.50	49.50	-13.00	QP			
4		56.9912	56.83	-20.73	36.10	49.50	-13.40	QP			
5		57.5940	54.95	-21.15	33.80	49.50	-15.70	QP			
6		58.4074	52.11	-21.51	30.60	49.50	-18.90	QP			



Above 1GHz:

Operation Mode:	TX	Test Date :	April 30, 2016
Frequency Range:	1000-40000MHz	Temperature :	21 °C
Test Result:	PASS	Humidity :	55 %
Measured Distance:	3m	Test By:	YH

Freq. (MHz)	Ant.Pol	Emission Level (dBuV)		Limit 3m (dBuV/m)		Margin(dB)	
		H/V	PK	AV	PK	AV	PK
6914.600	V	45.47	31.86	74.00	54.00	-28.53	-22.14
8512.600	V	46.40	30.38	74.00	54.00	-27.60	-23.62
11544.000	V	58.81	42.68	74.00	54.00	-15.19	-11.32
13357.600	V	51.64	37.75	74.00	54.00	-22.36	-16.25
14380.000	V	52.71	38.24	74.00	54.00	-21.29	-15.76
17644.000	V	54.40	36.90	74.00	54.00	-19.60	-17.10
--	--	--	--	--	--	--	--
7391.000	H	48.51	31.85	74.00	54.00	-25.49	-22.15
8975.000	H	49.28	34.44	74.00	54.00	-24.72	-19.56
11544.000	H	59.00	43.97	74.00	54.00	-15.00	-10.03
12947.600	H	52.80	37.86	74.00	54.00	-21.20	-16.14
14329.000	H	53.01	37.80	74.00	54.00	-20.99	-16.20
15996.000	H	49.80	37.64	74.00	54.00	-24.20	-16.36
--	--	--	--	--	--	--	--

- Note:** (1) All Readings are Peak Value and AV.  
(2) Emission Level= Reading Level+Probe Factor +Cable Loss  
(3) The average measurement was not performed when the peak measured data under the limit of average detection.  
(4)Data of measurement within this frequency range shown "--" in the table above means the reading of emissions are attenuated more than 20dB below the permissible limits or the field strength is too small to be measured

## **8. BAND EDGES MEASUREMENT**

### 8.1. Standard Applicable

According to 15.249(d), out band emission except for harmonics shall be comply with §15.209 or at least attenuated by 50 dB below the level of the fundamental.

### 8.2. Measurement Procedure

Same as 7.1 Radiated Emission Measurement.

### 8.3. Measurement Equipment

Same as 7.2 Radiated Emission Measurement.

### 8.4. Test Setup

Same as 7.3 Radiated Emission Measurement.

### 8.5. Test Results

**Pass**

The test plots as following:

Lower band edge

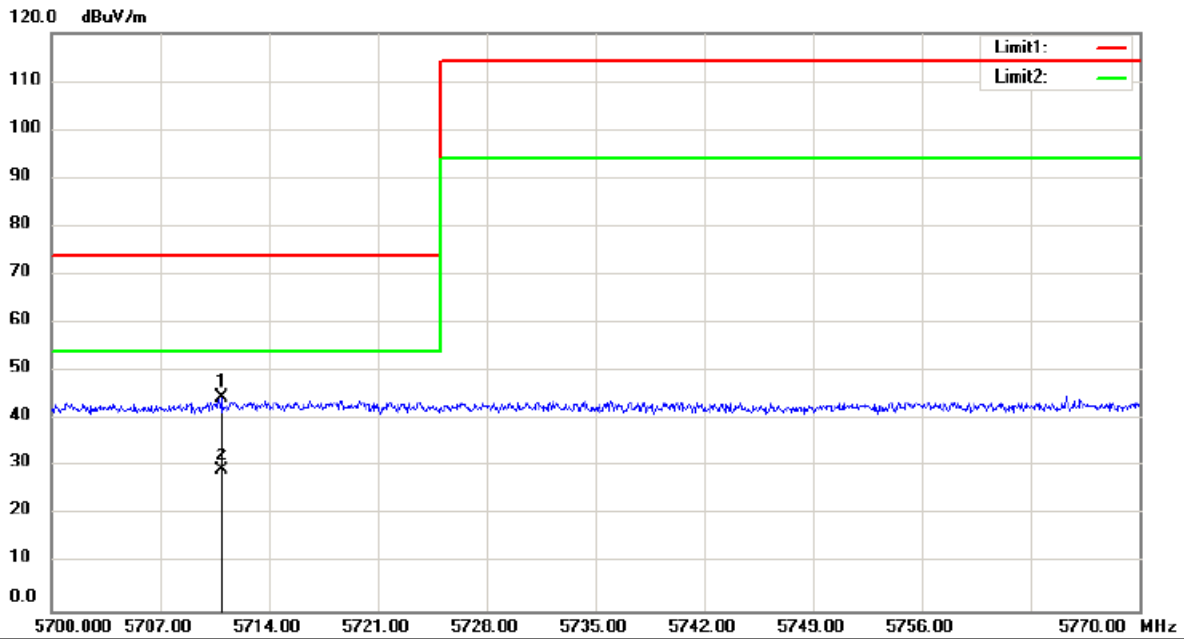

Site site #1 Polarization: **Horizontal** Temperature: 24 C  
 Limit: (RE)FCC PART 5G(Band Edge) Power: AC 120V/60Hz Humidity: 53 %  
 Mode:ON  
 Note:

No.	Mk.	Freq.	Reading Level	Correct Factor	Measurement	Limit	Over	Antenna Height	Table Degree	
		MHz	dBuV	dB	dBuV/m	dBuV/m	dB	cm	degree	Comment
1		5710.920	58.28	-13.69	44.59	74.00	-29.41			peak
2	*	5710.920	42.99	-13.69	29.30	54.00	-24.70			AVG

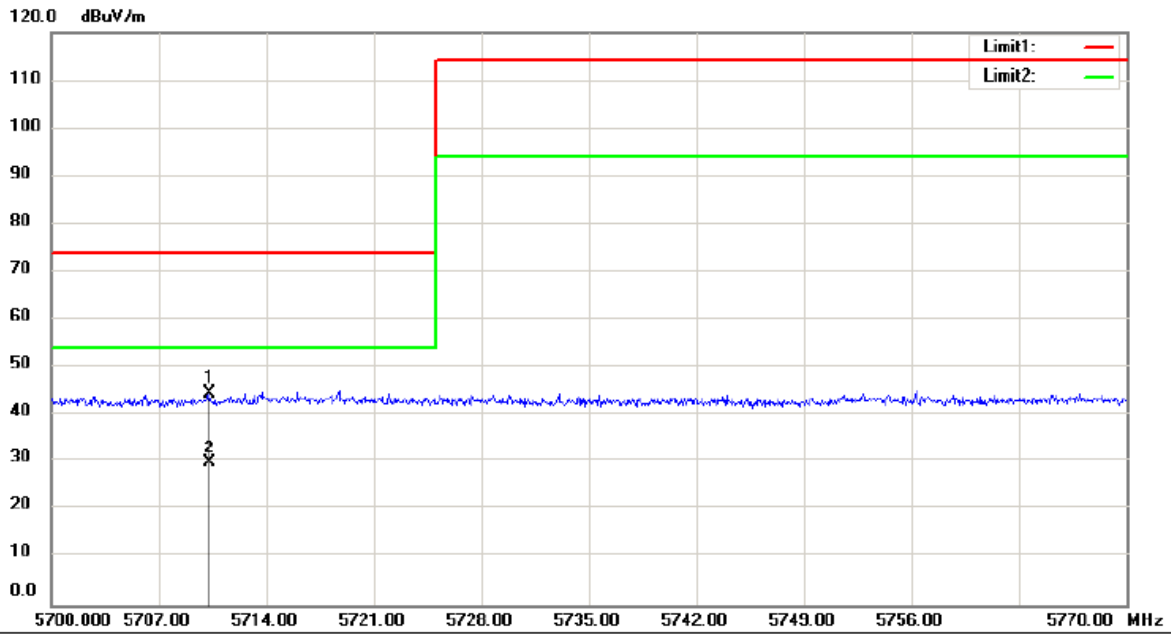

Site site #1 Polarization: **Vertical** Temperature: 24 C  
 Limit: (RE)FCC PART 5G(Band Edge) Power: AC 120V/60Hz Humidity: 53 %  
 Mode:ON  
 Note:

No.	Mk.	Freq. MHz	Reading Level dBuV	Correct Factor dB	Measure- ment dBuV/m	Limit dBuV/m	Over dB	Detector	Antenna Height cm	Table Degree degree	Comment
1		5710.290	58.38	-13.69	44.69	74.00	-29.31	peak			
2	*	5710.290	43.49	-13.69	29.80	54.00	-24.20	AVG			

Upper band edge

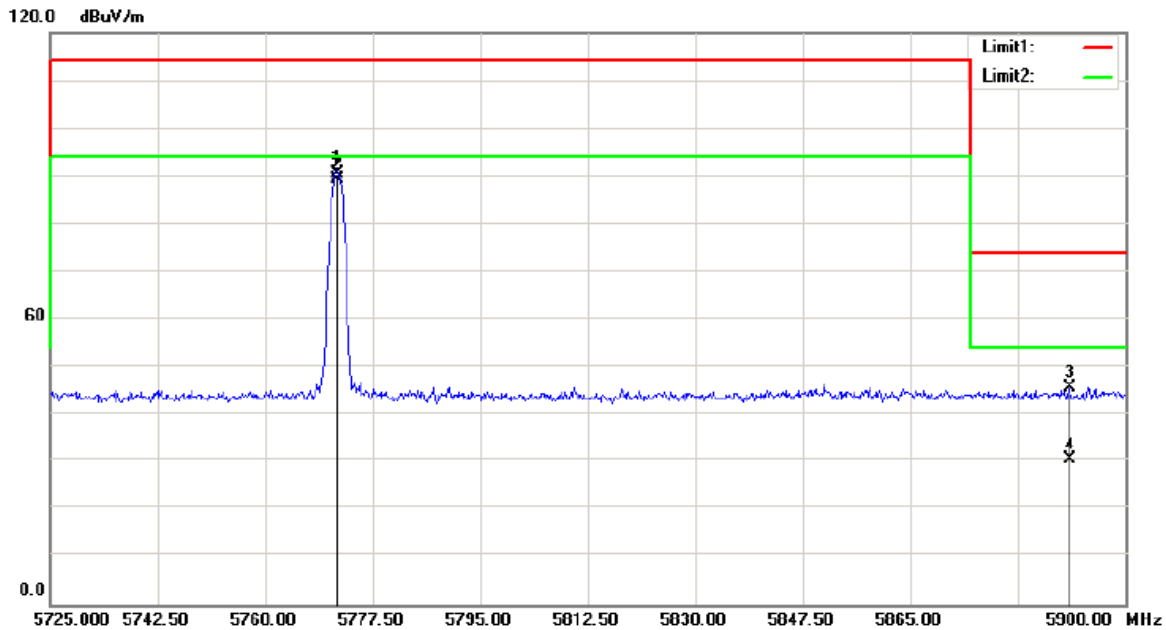

Site site #1 Polarization: *Horizontal* Temperature: 24  
 Limit: (RE)FCC PART 5G(Band Edge) Power: AC 120V/60Hz Humidity: 53 %  
 Mode:ON  
 Note:

No.	Mk.	Freq.	Reading Level	Correct Factor	Measurement	Limit	Over	Antenna Height	Table Degree	
		MHz	dBuV	dB	dBuV/m	dBuV/m	dB	cm	degree	Comment
1		5772.000	104.14	-13.59	90.55	114.00	-23.45	peak	0	
2	*	5772.000	102.79	-13.59	89.20	94.00	-4.80	AVG	0	
3		5890.900	59.24	-13.38	45.86	74.00	-28.14	peak	0	
4		5890.900	43.94	-13.38	30.56	54.00	-23.44	AVG	0	



## **9. ANTENNA APPLICATION**

### **9.1. Standard Applicable**

According to §15.203, an intentional radiator shall be designed to ensure that no antenna other than that furnished by the responsible party shall be used with the device.

### **9.2. Antenna Construction**

The EUT'S antenna is permanently integrated on the main EUT, no consideration of replacement. The antenna's gain is 0dBi and meets the requirement.

**---The End--**