



243 Jubug-Ri, Yangji-Myeon, Yongin-Si, Gyeonggi-Do, Korea 17159
 Tel: +82-31-323-6008 Fax: +82-31-323-6010
<http://www.ltalab.com>

Dates of Tests: December 16, 2018 ~ January 19, 2019
 Test Report S/N: LR50011901E
 Test Site : LTA CO., LTD.

CERTIFICATION OF COMPLIANCE

FCC ID.	2AH34AIM-10
APPLICANT	SPIRE TECHNOLOGY INC.

Equipment Class	:	Digital Transmission System (DTS)
Manufacturing Description	:	Audio Interface Module
Manufacturer	:	SPIRE TECHNOLOGY INC.
Model name	:	AIM-1.0
Test Device Serial No.:	:	Identical prototype
Rule Part(s)	:	FCC Part 15.247 Subpart C ; ANSI C-63.4-2014
Frequency Range	:	2402 ~ 2480 MHz
Max. Output Power	:	Max 9.22 dBm – Conducted
Data of issue	:	January 19, 2019

This test report is issued under the authority of:

The test was supervised by:

JaBeom.Koo

HeeCheon

Ja-Beom, Koo / Director

Hee-Cheon, Kwon, Test Engineer

This test result only responds to the tested sample. It is not allowed to copy this report even partly without the allowance of the test laboratory. The report must not be used by the client to claim product certification, approval, or endorsement by NVLAP, NIST, or any agency of the Federal Government.



NVLAP LAB Code.: 200723-0

TABLE OF CONTENTS

1. GENERAL INFORMATION	-----	3
2. INFORMATION ABOUT TEST ITEM	-----	4
3. TEST REPORT	-----	5
3.1 SUMMARY OF TESTS	-----	5
3.2 TECHNICAL CHARACTERISTICS TEST	-----	6
3.2.1 6 dB BANDWIDTH	-----	6
3.2.2 PEAK OUTPUT POWER	-----	9
3.2.3 POWER SPECTRAL DENSITY	-----	12
3.2.4 BAND EDGE	-----	15
3.2.5 CONDUCTED SPURIOUS EMISSIONS	-----	18
3.2.6 RADIATED SPURIOUS EMISSIONS	-----	21
3.2.7 AC Conducted Emissions	-----	32
APPENDIX		
APPENDIX TEST EQUIPMENT USED FOR TESTS	-----	39

1. General information

1-1 Test Performed

Company name : LTA Co., Ltd.
 Address : 243, Jubug-ri, Yangji-Myeon, Youngin-Si, Kyunggi-Do, Korea. 17159
 Web site : <http://www.ltalab.com>
 E-mail : chahn@ltalab.com
 Telephone : +82-31-323-6008
 Facsimile : +82-31-323-6010

Quality control in the testing laboratory is implemented as per ISO/IEC 17025 which is the “General requirements for the competents of calibration and testing laboratory”.

1-2 Accredited agencies

LTA Co., Ltd. is approved to perform EMC testing by the following agencies:

Agency	Country	Accreditation No.	Validity	Reference
NVLAP	U.S.A	200723-0	2019-09-30	ECT accredited Lab.
RRA	KOREA	KR0049	-	EMC accredited Lab.
FCC	U.S.A	649054	2019-04-13	FCC CAB
VCCI	JAPAN	C-4948,	2020-09-10	VCCI registration
VCCI	JAPAN	T-2416,	2020-09-10	VCCI registration
VCCI	JAPAN	R-4483(10 m),	2020-10-15	VCCI registration
IC	CANADA	5799A-1	2019-11-07	IC filing
KOLAS	KOREA	NO.551	2021-08-20	KOLAS accredited Lab.

2. Information about test item

2-1 Client & Manufacturer

Company name : SPIRE TECHNOLOGY INC.
 Address : 7F., 3Dong, Pangyo-Seven-Venture-Valley 1 SamPyeong-Dong, 625,
 Bundang-gu SeongNam-Si, Gyeonggi-Do, South Korea
 Tel / Fax : TEL No +82-10-8841-3369

2-2 Equipment Under Test (EUT)

Model name : AIM-1.0
 Serial number : Identical prototype
 Date of receipt : December 16, 2018
 EUT condition : Pre-production, not damaged
 Antenna type : Chip Antenna (Max Gain : -0.53 dBi)
 Frequency Range : 2402 ~ 2480 MHz
 RF output power : Max 9.22 dBm – Conducted
 Number of channels : 40
 Type of Modulation : GFSK
 Power Source : 5.0 Vdc

2-3 Tested frequency

	LOW	MID	HIGH
Frequency (MHz)	2402	2442	2480

2-4 Ancillary Equipment

Equipment	Model No.	Serial No.	Manufacturer
Notebook	CR720	MS-1736	MSI

3. Test Report

3.1 Summary of tests

FCC Part Section(s)	Parameter	Limit	Test Condition	Status (note 1)
15.247(a)	6 dB Bandwidth	> 500 kHz	Conducted	C
15.247(b)	Transmitter Peak Output Power	< 1 Watt		C
15.247(d)	Transmitter Power Spectral Density	< 8 dBm @ 3 kHz		C
15.247(d)	Band Edge	> 20 dBc		C
15.209	Field Strength of Harmonics	Emission	Radiated	C
15.207	AC Conducted Emissions	Emissions	Conducted	N/A
15.203	Antenna requirement	-	-	C

Note 1: C=Complies NC=Not Complies NT=Not Tested NA=Not Applicable

Note 2: The data in this test report are traceable to the national or international standards.

The above equipment was tested by LTA Co., Ltd. The test data, data evaluation, test procedures, and equipment configurations shown in this report were made in accordance with the procedures given in ANSI C63.10-2013 and the energy emitted by the sample EUT tested as described in this report is in compliance with the requirements of FCC Rules Part 2 and Part 15.247 The test results of this report relate only to the tested sample identified in this report.

→ Antenna Requirement

SPIRE TECHNOLOGY INC. FCC ID: 2AH34AIM-1.0 unit complies with the requirement of §15.203.

The antenna type is Chip Antenna.

3.2 Technical Characteristics Test

3.2.1 6 dB Bandwidth

Procedure:

The bandwidth at 6 dB below the highest in-band spectral density was measured with a spectrum analyzer connected to the antenna terminal, while EUT is operating in transmission mode at the appropriate frequencies.

After the trace being stable, Use the marker-to-peak function to set the marker to the peak of the emission. Use the marker-delta function to measure 6 dB down one side of the emission. Reset the marker-delta function, and move the marker to the other side of the emission, until it is (as close as possible to) even with the reference marker level. The marker-delta reading at this point is the 6 dB bandwidth of the emission.

The spectrum analyzer is set to:

Center frequency = the highest, middle and the lowest channels

RBW = 100 kHz

Span = 5 MHz

VBW = 300 kHz (VBW \geq RBW)

Sweep = auto

Trace = max hold

Detector function = peak

Measurement Data : **Complies**

Frequency (MHz)	Test Results	
	Measured Bandwidth (MHz)	Result
2402	0.4848	Complies
2442	0.4848	Complies
2480	0.4848	Complies

- See next pages for actual measured spectrum plots.

Minimum Standard:

6 dB Bandwidth > 500 kHz

Measurement Setup

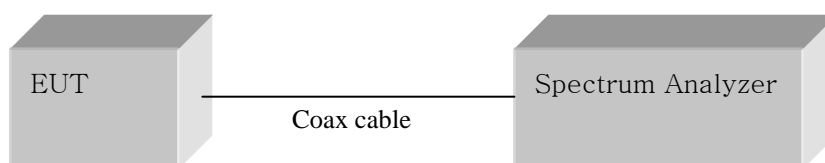
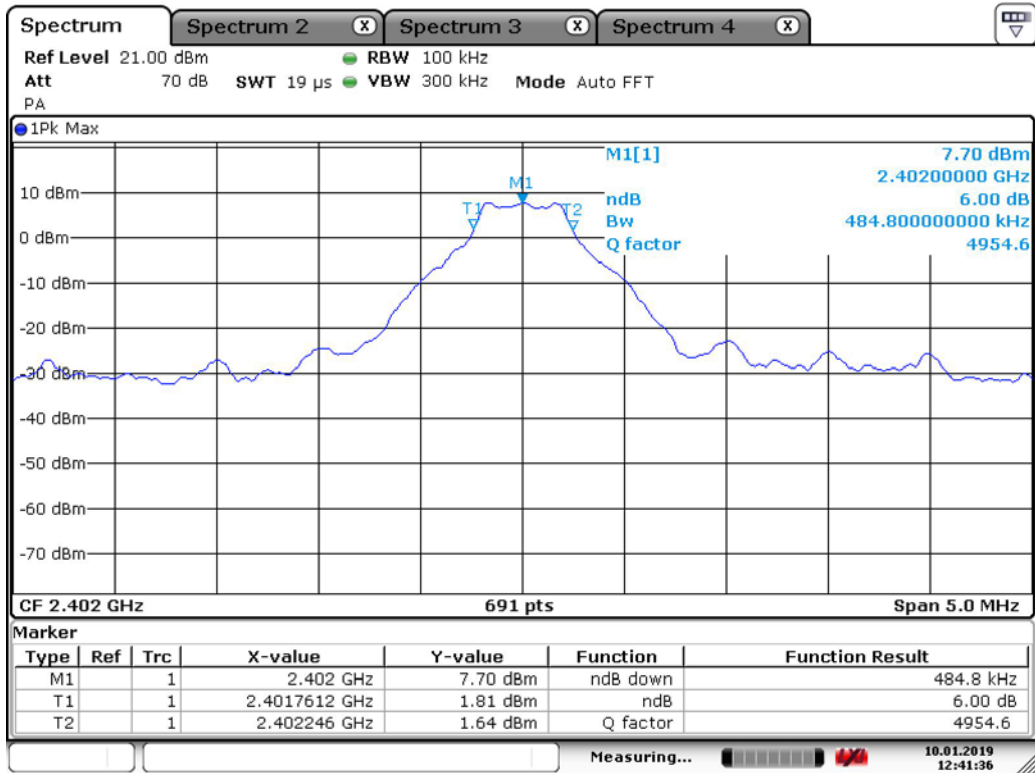

Figure 1: Measurement setup for the carrier frequency separation

Low Channel



Date: 10.JAN.2019 12:41:36

Middle Channel

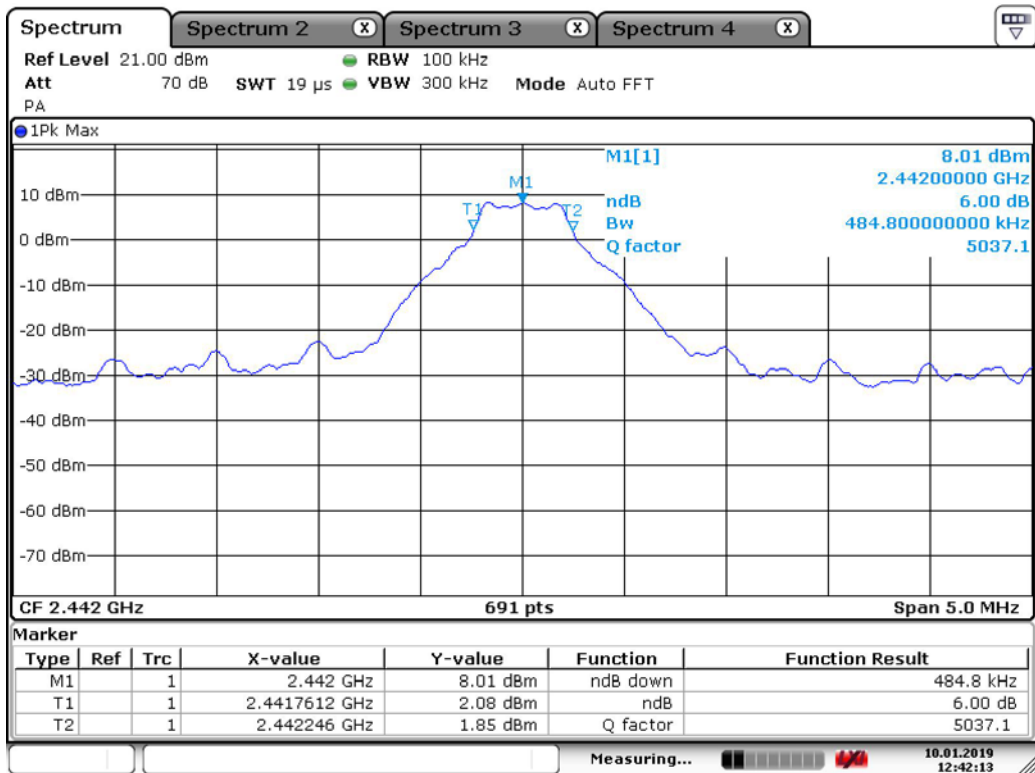

Date: 10.JAN.2019 12:42:14

High Channel

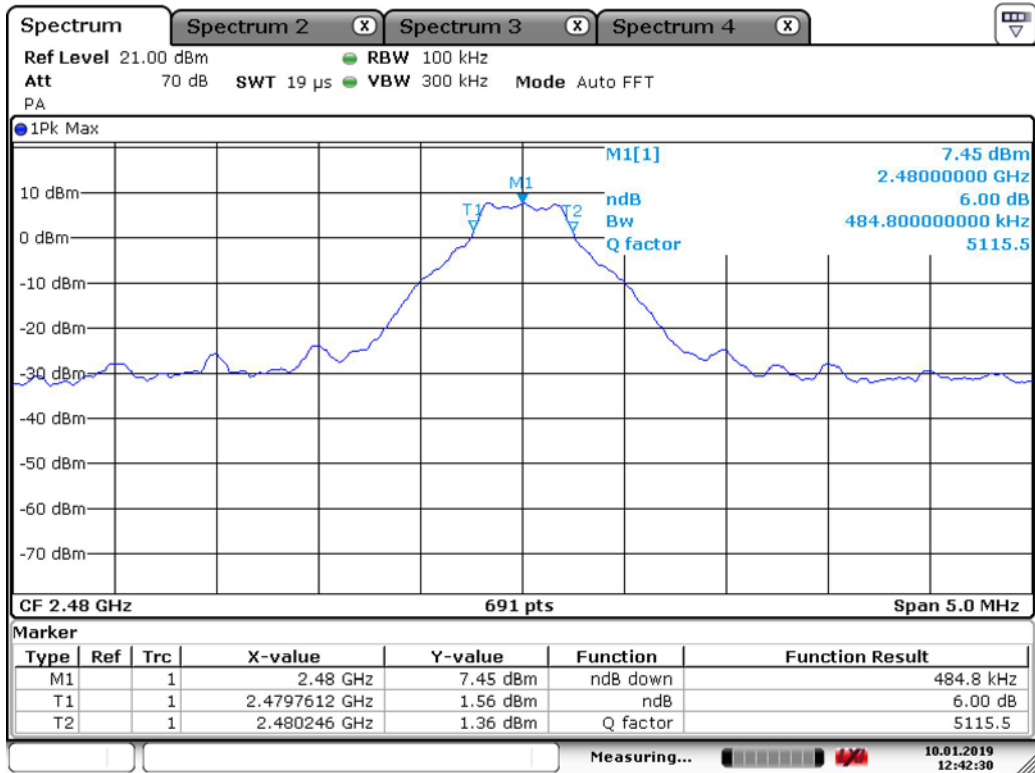

Date: 10.JAN.2019 12:42:30

3.2.2 Peak Output Power Measurement

Procedure:

The maximum peak output power was measured with the spectrum analyzer connected to the antenna output of the EUT. The spectrum analyzer's internal channel power integration function is used to integrate the power over a bandwidth greater than or equal to the 99 % bandwidth. The EUT was operating in transmit mode at the appropriate center frequency.

The spectrum analyzer is set to:

Center frequency = the highest, middle and the lowest channels

RBW = 1 MHz

Span = auto

VBW = 3 MHz (VBW \geq RBW)

Sweep = auto

Detector function = peak

Measurement Data : **Complies**

Frequency (MHz)	Test Results		
	dBm	mW	Result
2402	9.03	8.00	Complies
2442	9.22	8.36	Complies
2480	8.72	7.45	Complies

- See next pages for actual measured spectrum plots.

Minimum Standard:

Peak output power	< 1 W
-------------------	-------

Measurement Setup

Same as the Chapter 3.2.1 (Figure 1)

Low Channel

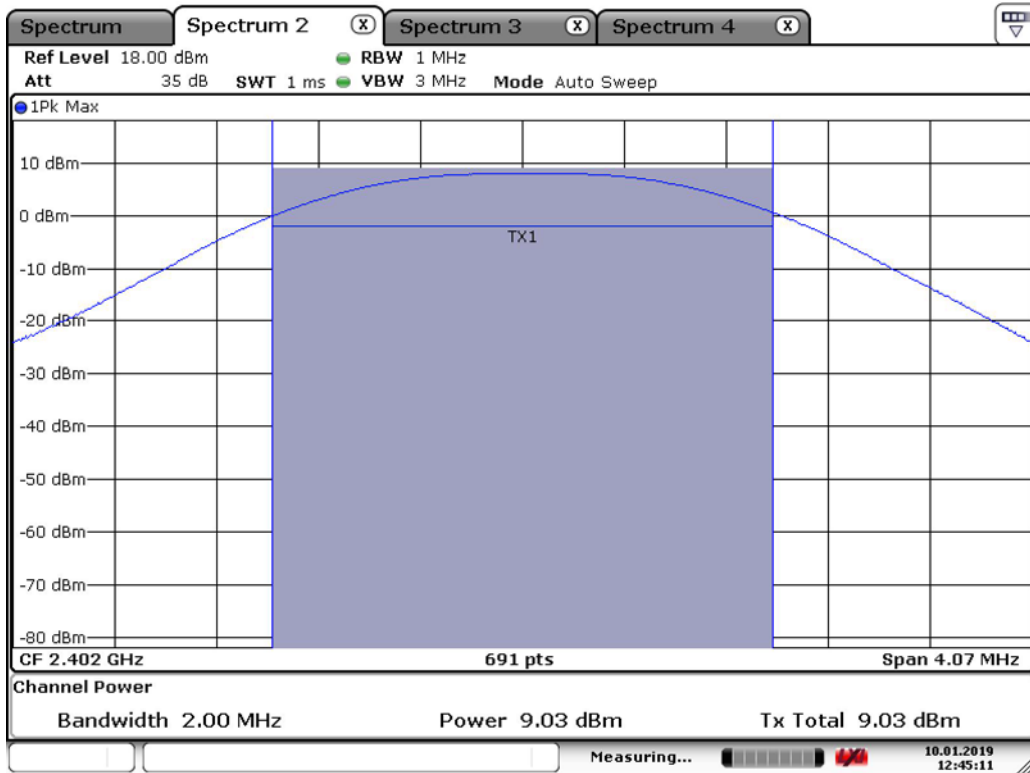

Middle Channel

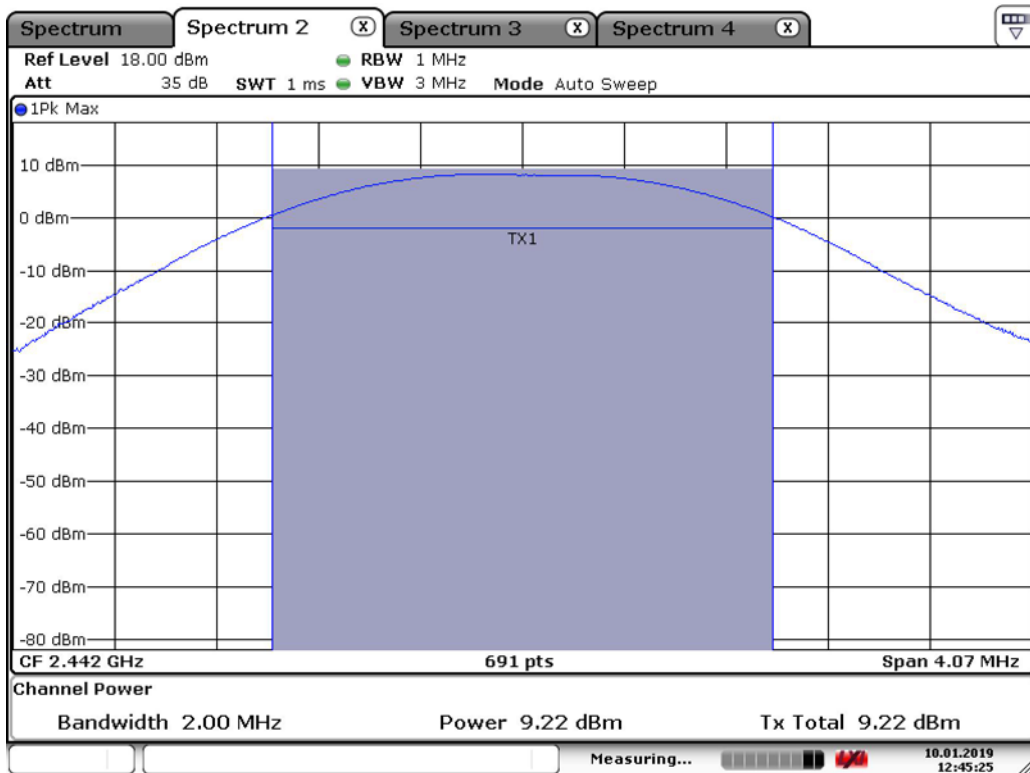

High Channel

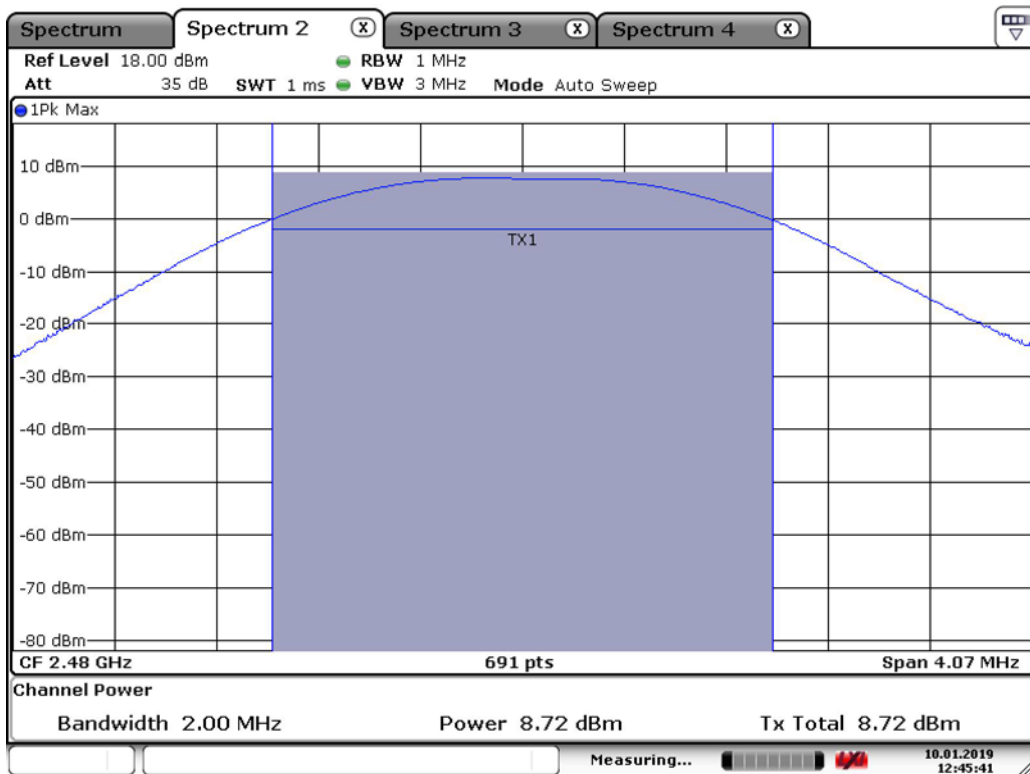

Date: 10.JAN.2019 12:45:41

3.2.3 Power Spectral Density

Procedure:

The peak power density is measured with a spectrum analyzer connected to the antenna terminal while the EUT is operating in transmission mode at the appropriate frequencies.

The spectrum analyzer is set to:

RBW = 3 kHz ($3 \text{ kHz} \leq \text{RBW} \leq 100 \text{ kHz}$) Span = 1.5 times the DTS bandwidth

VBW = 10 kHz (3 X RBW) Sweep = auto

Detector function = peak Trace = max hold

Measurement Data : **Complies**

Frequency (MHz)	Test Results	
	dBm/ 3 kHz BW	Result
2402	-4.85	Complies
2442	-4.61	Complies
2480	-5.14	Complies

- See next pages for actual measured spectrum plots.

Minimum Standard:

Power Spectral Density	< 8 dBm @ 3 kHz BW
------------------------	--------------------

Measurement Setup

Same as the Chapter 3.2.1 (Figure 1)

Power Density Measurement Low Channel

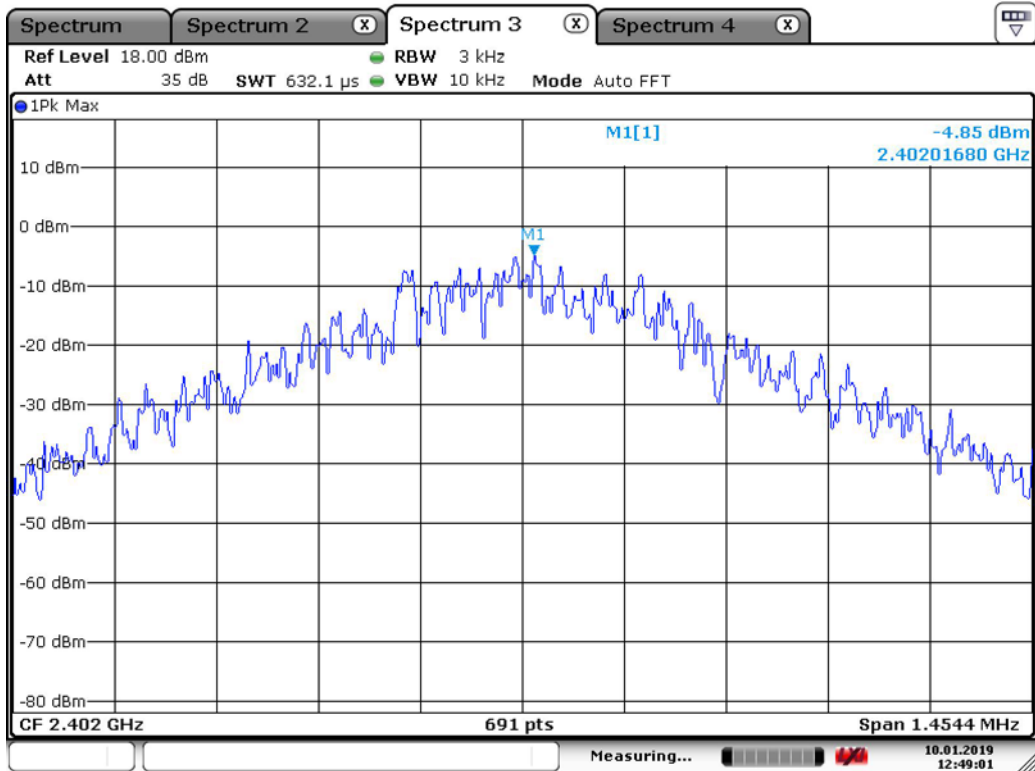

Date: 10.JAN.2019 12:49:01

Middle Channel

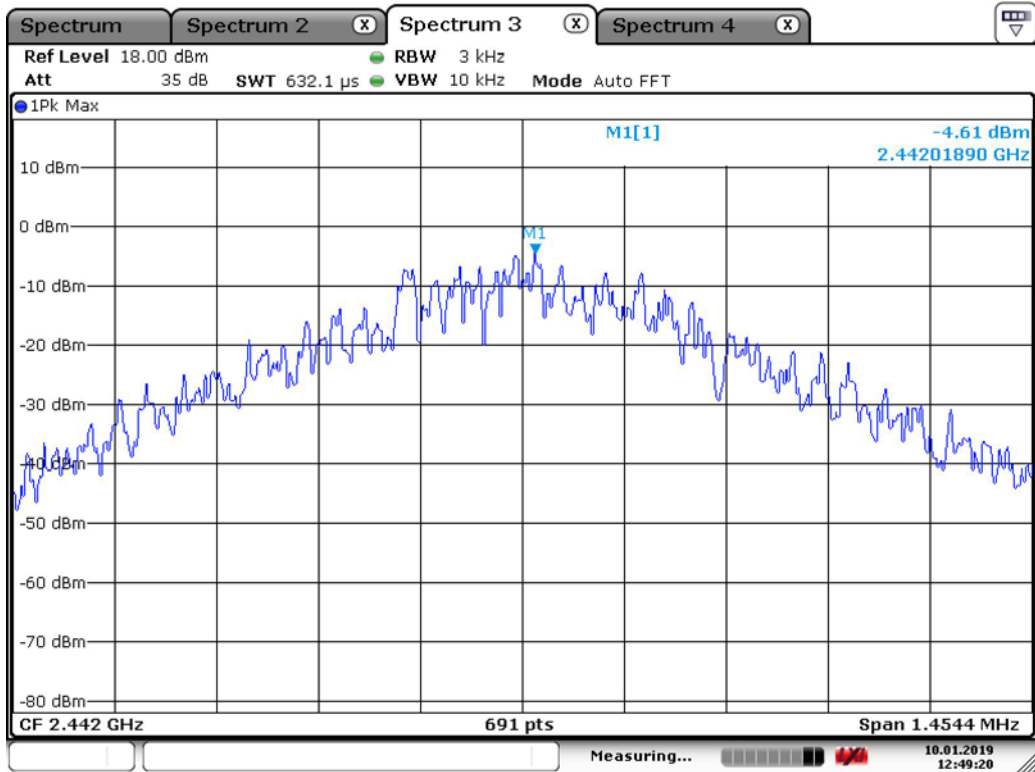

Date: 10.JAN.2019 12:49:20

High Channel

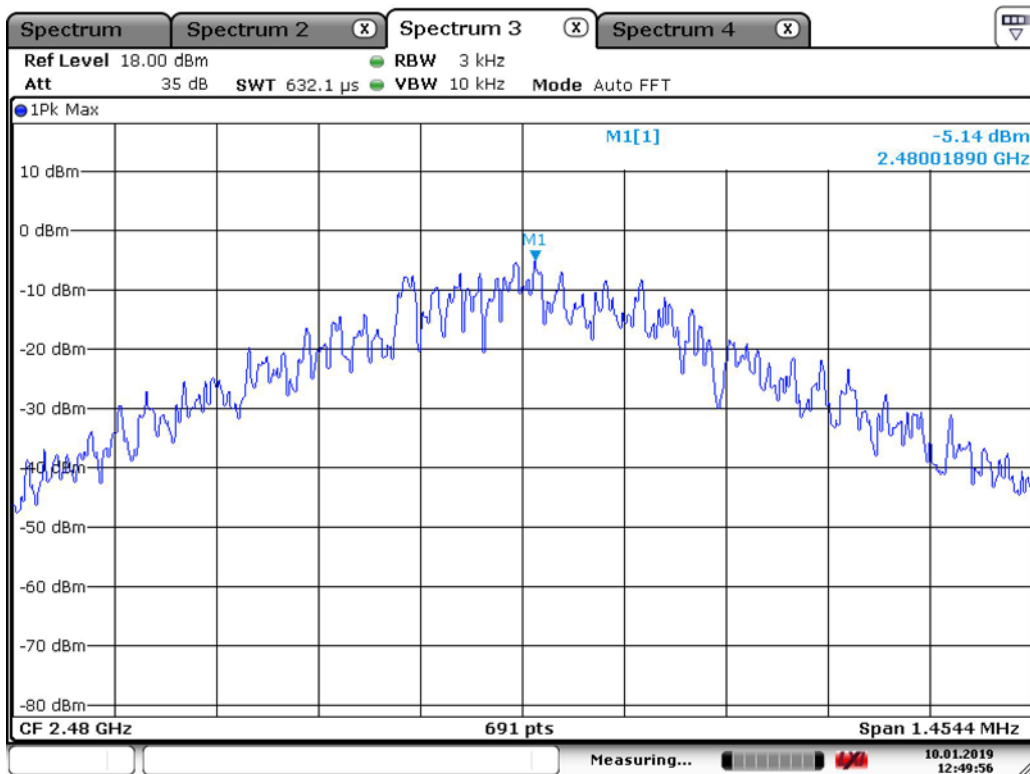

Date: 10.JAN.2019 12:49:57

Lower edge

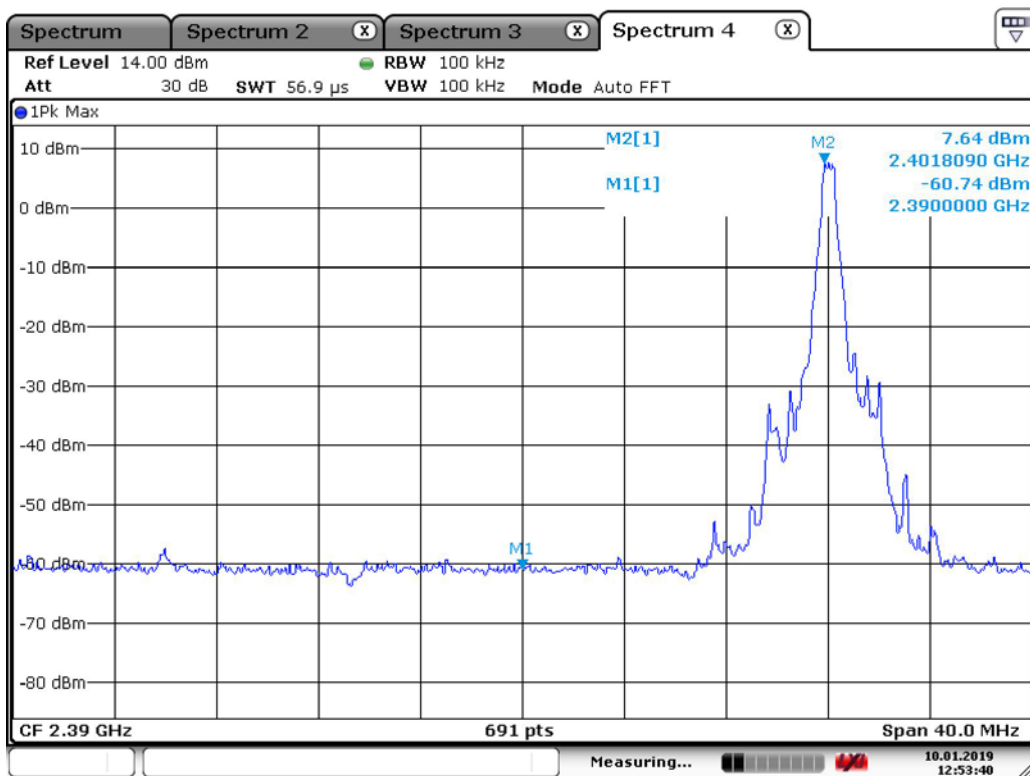

Date: 10.JAN.2019 12:53:40

Upper edge

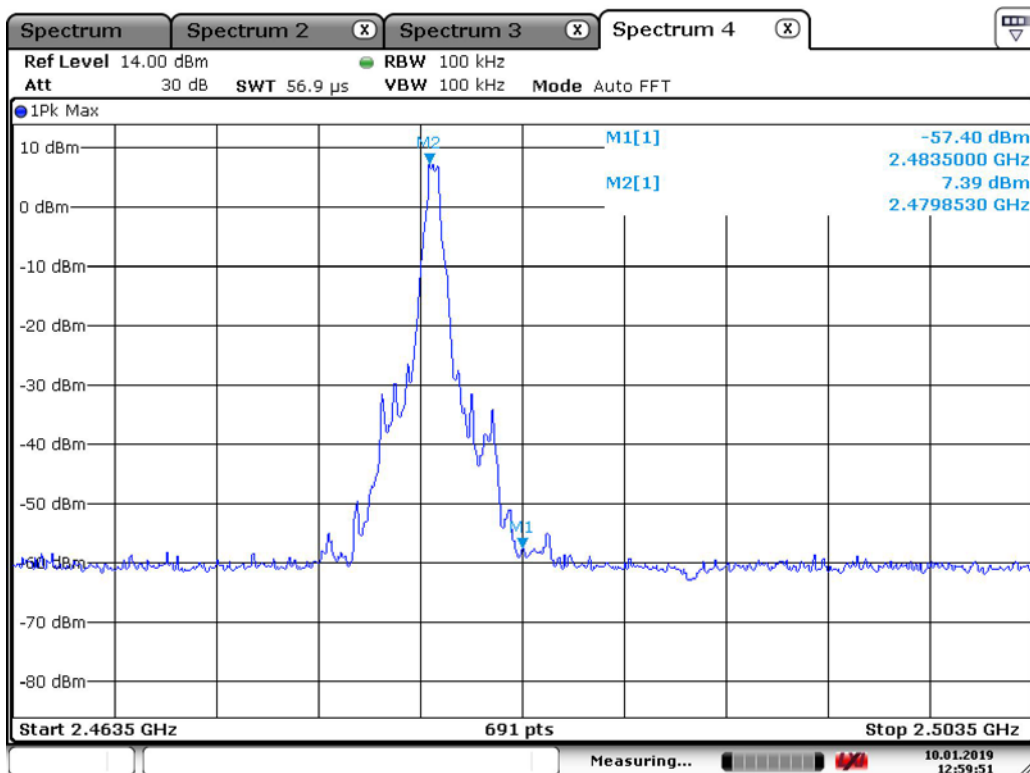

Date: 10.JAN.2019 12:59:50

Radiated Band-edges in the restricted band 2310-2390 MHz measurement

Frequency [MHz]	Reading [dBuV/m]		Pol.	Correction Factor	Limits [dBuV/m]		Result [dBuV/m]		Margin [dB]	
	AV	Peak			AV	Peak	AV	Peak	AV	Peak
2389.81	46.28	47.83	H	-9.37	54.0	74.0	36.91	38.46	17.09	35.54
2389.87	50.62	52.07	H	-9.37	54.0	74.0	41.25	42.70	12.75	31.30
2352.81	50.24	51.28	H	-9.38	54.0	74.0	40.86	41.90	13.14	32.10

Radiated Band-edges in the restricted band 2483.5-2500 MHz measurement

Frequency [MHz]	Reading [dBuV/m]		Pol.	Correction Factor	Limits [dBuV/m]		Result [dBuV/m]		Margin [dB]	
	AV	Peak			AV	Peak	AV	Peak	AV	Peak
2490.96	49.17	49.02	H	-9.24	54.0	74.0	39.80	39.65	14.20	34.35
2491.12	48.44	49.83	H	-9.24	54.0	74.0	39.07	40.46	14.93	33.54
2490.84	46.56	58.02	H	-9.24	54.0	74.0	37.18	48.64	16.82	25.36

Note : This EUT was tested in 3 orthogonal positions and the worst-case data was presented

3.2.5 Conducted Spurious Emissions

Procedure:

The test follows KDB558074. The conducted spurious emissions were measured with a spectrum analyzer connected to the antenna terminal, while EUT had its hopping function disabled at the highest, middle and the lowest available channels..

After the trace being stable, set the marker on the peak of any spurious emission recorded.

The spectrum analyzer is set to:

Span = wide enough to capture the peak level of the in-band emission and all spurious emissions

RBW = 100 kHz

Sweep = auto

VBW = 100 kHz

Detector function = peak

Trace = max hold

Measurement Data: **Complies**

- All conducted emission in any 100 kHz bandwidth outside of the spread spectrum band was at least 20 dB lower than the highest inband spectral density. Therefore the applying equipment meets the requirement.
- See next pages for actual measured spectrum plots.

Minimum Standard:	> 20 dBc
--------------------------	----------

Measurement Setup

Same as the Chapter 3.2.1 (Figure 1)

Unwanted Emission – Low Channel
Frequency Range = 30 MHz ~ 26.5 GHz

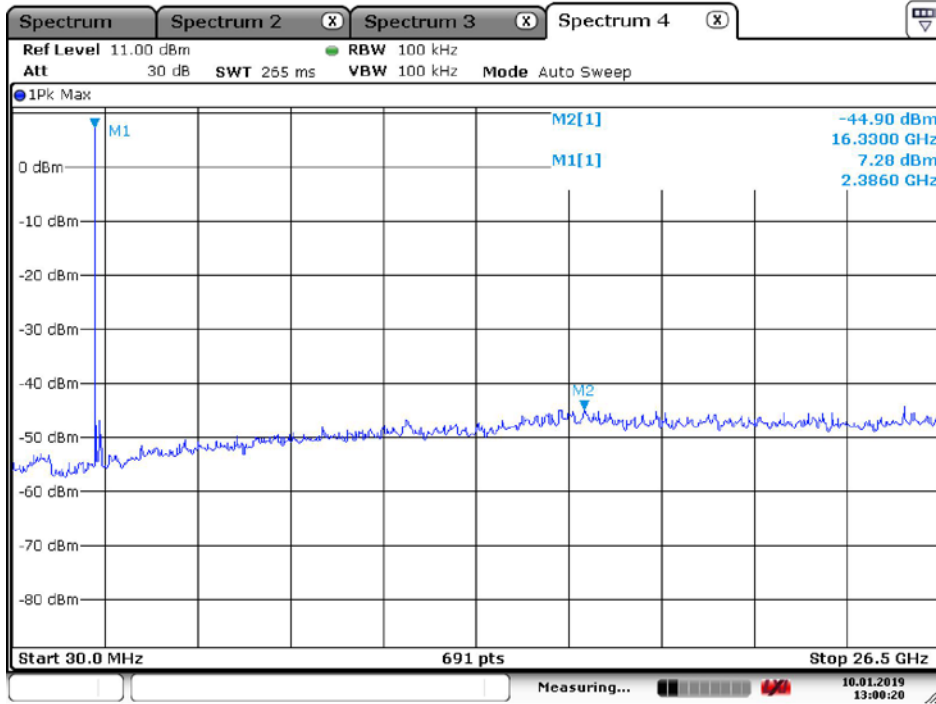

Date: 10.JAN.2019 13:00:20

Unwanted Emission – Middle Channel
Frequency Range = 30 MHz ~ 26.5 GHz

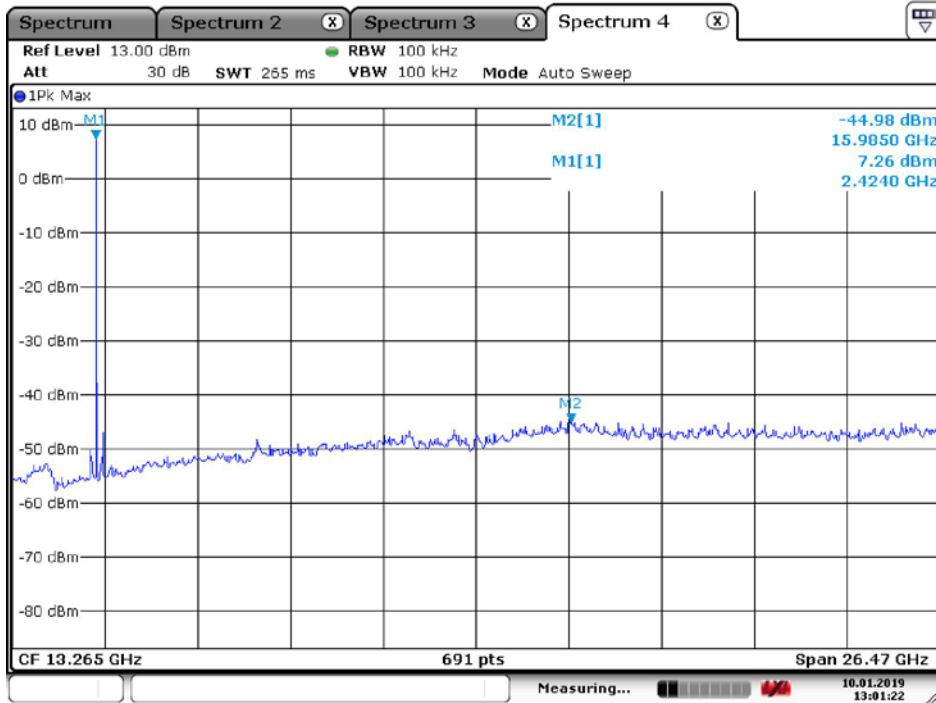

Date: 10.JAN.2019 13:01:22

Unwanted Emission – High Channel
Frequency Range = 30 MHz ~ 26.5 GHz

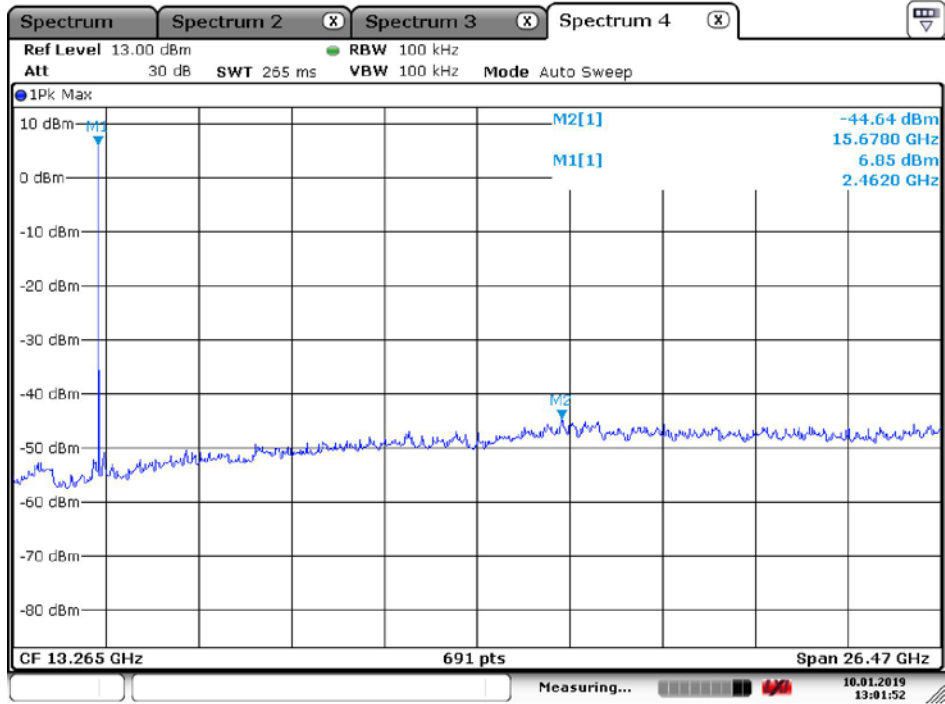

Date: 10.JAN.2019 13:01:53

3.2.6 Radiated Spurious Emissions

Procedure:

Radiated emissions from 30 MHz to 25 GHz were measured according to the methods defines in ANSI C63.10-2013.

The EUT is a placed on as turn table. For emissions testing at or below 1 GHz, the table height shall be 0.8 m above the reference ground plane. For emission measurements above 1 GHz, the table height shall be 1.5 m. The turn table shall rotate 360 degrees to determine the position of maximum emission level. EUT is set 3m away from the receiving antenna which varied from 1m to 4m to find out the highest emission. And also, each emission was to be maximized by changing the polarization of receiving antenna both horizontal and vertical. In order to find out the max. emission, the relative positions of this hand-held transmitter (EUT) was rotated through three orthogonal axes and measurement procedures for electric field radiated emissions above 1 GHz the EUT measurement is to be made “while keeping the antenna in the ‘cone of radiation’ from that area and pointed at the area both in azimuth and elevation, with polarization oriented for maximum response.” is still within the 3dB illumination BW of the measurement antenna.

The spectrum analyzer is set to:

Center frequency = the worst channel

Frequency Range = 9 kHz ~ 10th harmonic.

RBW = 100 kHz (30 MHz ~ 1 GHz)

= 1 MHz (1 GHz ~ 10th harmonic)

Span = 100 MHz

Trace = max hold

VBW \geq RBW

Detector function = peak

Sweep = auto

below 30 MHz

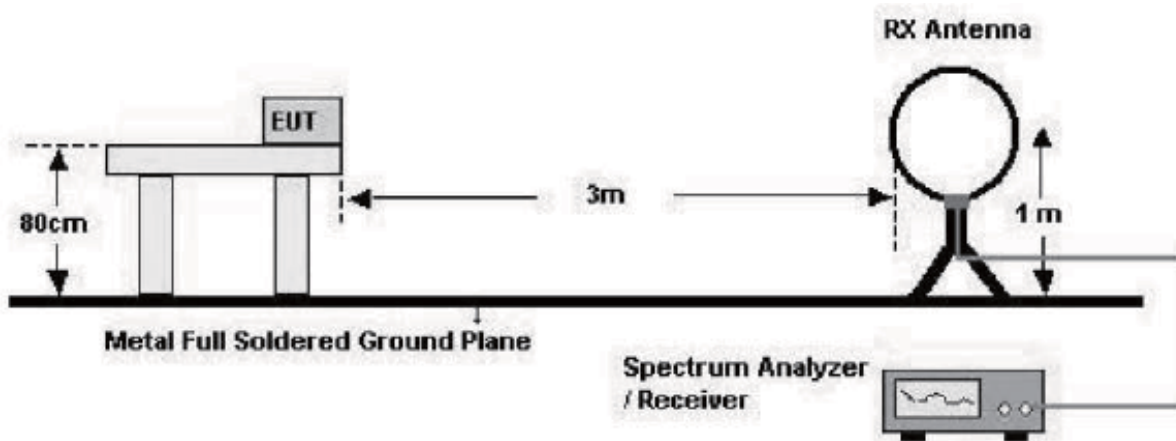

below 1 GHz (30 MHz to 1 GHz)

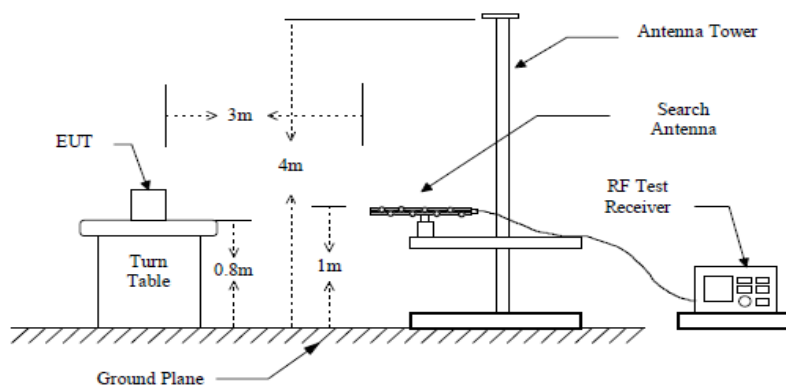

above 1 GHz

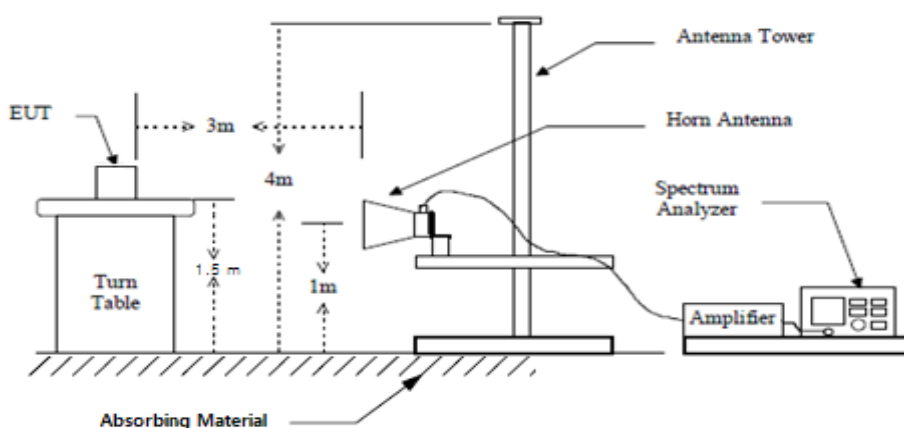

Measurement Data: **Complies**

- See next pages for actual measured data.
- No other emissions were detected at a level greater than 20 dB below limit include from 9 kHz to 30MHz.

Minimum Standard: FCC Part 15.209(a)

Frequency (MHz)	Limit (uV/m) @ 3 m
0.009 ~ 0.490	2400/F(kHz) (@ 300 m)
0.490 ~ 1.705	24000/F(kHz) (@ 30 m)
1.705 ~ 30	30(@ 30 m)
30 ~ 88	100 **
88 ~ 216	150 **
216 ~ 960	200 **
Above 960	500

** Except as provided in 15.209(g), fundamental emissions from intentional radiators operating under this Section shall not be located in the frequency bands 54-72 MHz, 76-88 MHz, 174-216 MHz or 470-806 MHz. However, operation within these frequency bands is permitted under other sections of this Part, e.g. 15.231 and 15.241.

Measurement Data : (Above 1 GHz)

Frequency [MHz]	Reading [dBuV/m]		Pol.	Correction Factor		Limits [dBuV/m]		Result [dBuV/m]		Margin [dB]	
	AV	Peak		AV	Peak	AV	Peak	AV	Peak	AV	Peak
15709.00	29.52	42.35	H	8.60		54.0	74.0	38.12	50.95	15.88	23.05
17587.00	34.84	50.02	H	14.32		54.0	74.0	34.84	50.02	19.16	23.98
17852.00	20.64	35.69	H	14.96		54.0	74.0	35.60	50.65	18.40	23.35

- No other emissions were detected at a level greater than 20 dB below limit.

Measurement Data: (9 kHz – 30 MHz)

Frequency [MHz]	Reading [dBuV/m]		Pol.	Correction Factor		Limits [dBuV/m]		Result [dBuV/m]		Margin [dB]	
	AV	Peak		Antenna	Amp.Gain+Cable	AV	Peak	AV	Peak	AV	Peak
	-	-		-	-	-	-	-	-	-	-
-	-	-	-	-	-	-	-	-	-	-	-
*No emissions were detected at a level greater than 20 dB below limit.											
-	-	-	-	-	-	-	-	-	-	-	-

- No other emissions were detected at a level greater than 20 dB below limit.

Radiated Emissions (Below 1 GHz) – Operating mode



4, Songjuro 236Beon-gil, yanggi-myeon,
Yongin-si, Gyeonggi-do, Korea
Tel : +82-31-3236008,9
Fax : +82-31-3236010
www.ltalab.com

EUT/Model No.: AIM-1.0 Temp/Humi: 20 / 31

 Test Mode : Operating mode Tested by: Kwon H C

Data: 1870 File: C:\Program Files (x86)\e3\1812-2.EM6 (1877) Date: 2019-01-11

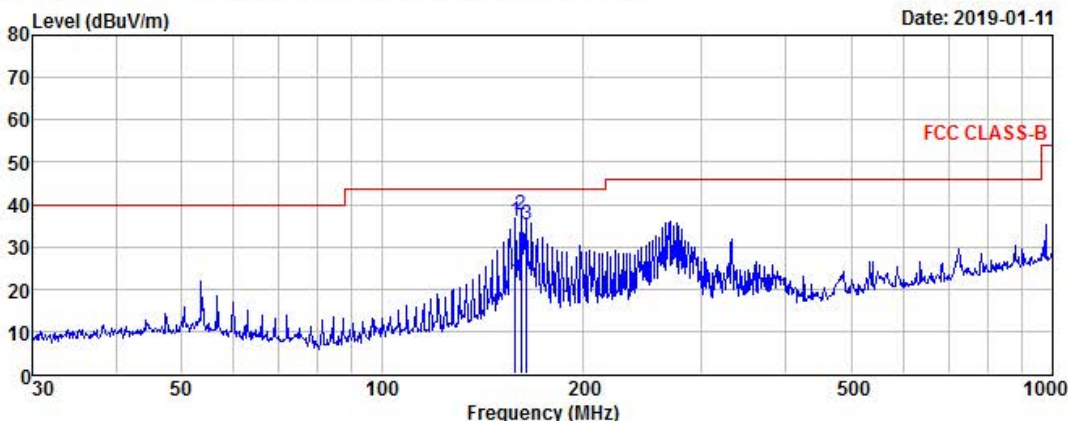

Freq MHz	Reading dBuV	C.F dB	Result QP dBuV/m	Limit dBuV/m	Margin dB	Height cm	Angle deg	Polarity
158.11	47.96	-12.10	35.86	43.50	7.64	364	125	HORIZONTAL
161.47	49.48	-12.16	37.32	43.50	6.18	310	273	HORIZONTAL
164.33	47.54	-12.43	35.11	43.50	8.39	386	299	HORIZONTAL

Remarks: C.F (Correction Factor) = Antenna factor + Cable loss - Preamp gain

Radiated Emissions (Above 1 GHz) – Bluetooth(LOW) mode



4, Songjuro 236Beon-gil, yanggi-myeon,
Yongin-si, Gyeonggi-do, Korea
Tel : +82-31-3236008,9
Fax : +82-31-3236010
www.ltalab.com

EUT/Model No.: AIM-1.0 Temp/Humi: 20 / 31
Test Mode : Operating mode(LOW) Tested by: Kwon H C

Data: 1872 File: C:\Program Files (x86)\e3\1812-2.EM6 (1877)

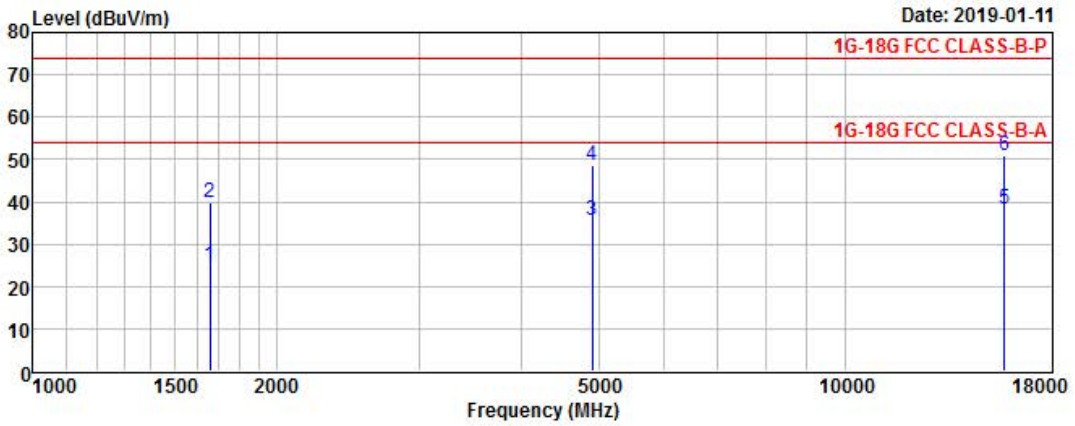

Freq	Reading	C.F	Result	Limit	Margin	Height	Angle	Polarity
MHz	dBuV	dB	QP dBuV/m	dBuV/m	dB	cm	deg	
1657.00	36.87	-11.91	24.96	54.00	29.04	357	152	HORIZONTAL
1657.00	51.87	-11.91	39.96	74.00	34.04	357	152	HORIZONTAL
4899.00	37.61	-2.09	35.52	54.00	18.48	258	267	HORIZONTAL
4899.00	50.79	-2.09	48.70	74.00	25.30	258	267	HORIZONTAL
15709.00	29.52	8.60	38.12	54.00	15.88	362	94	HORIZONTAL
15709.00	42.35	8.60	50.95	74.00	23.05	362	94	HORIZONTAL

Remarks: C.F (Correction Factor) = Antenna factor + Cable loss - Preamp gain



4, Songjuro 236Beon-gil, yanggi-myeon,
Yongin-si, Gyeonggi-do, Korea
Tel : +82-31-3236008,9
Fax : +82-31-3236010
www.ltalab.com

EUT/Model No.: AIM-1.0 Temp/Humi: 20 / 31
Test Mode : Operating mode(LOW) Tested by: Kwon H C

Data: 1877 File: C:\Program Files (x86)\e3\1812-2.EM6 (1877)

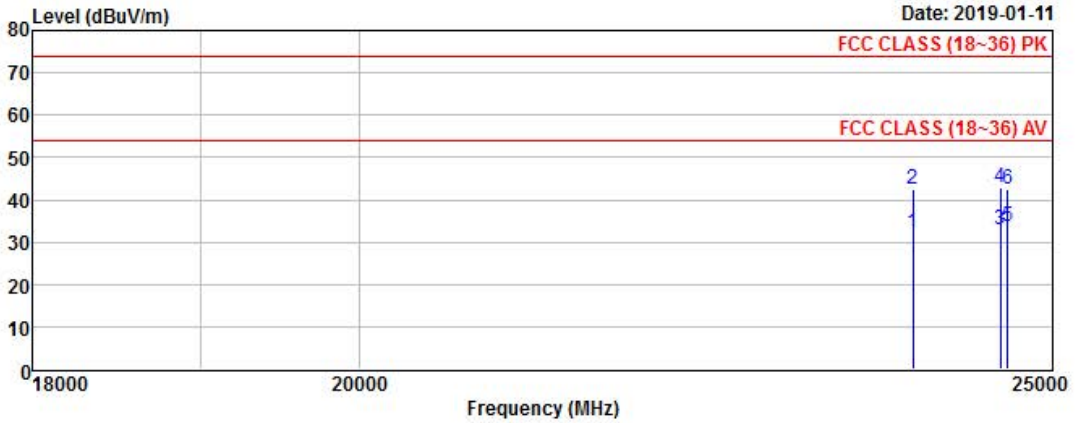

Freq	Reading	C.F	Result	Limit	Margin	Height	Angle	Polarity
MHz	dBuV	dB	QP dBuV/m	dBuV/m	dB	cm	deg	
23899.00	24.96	7.17	32.13	54.00	21.87	236	207	HORIZONTAL
23899.00	35.17	7.17	42.34	74.00	31.66	236	207	HORIZONTAL
24585.00	25.61	7.14	32.75	54.00	21.25	366	167	HORIZONTAL
24585.00	35.88	7.14	43.02	74.00	30.98	366	167	HORIZONTAL
24639.00	26.41	7.14	33.55	54.00	20.45	324	192	HORIZONTAL
24639.00	35.46	7.14	42.60	74.00	31.40	324	192	HORIZONTAL

Remarks: C.F (Correction Factor) = Antenna factor + Cable loss - Preamp gain

Bluetooth(MID) mode



4, Songjuro 236Beon-gil, yanggi-myeon,
Yongin-si, Gyeonggi-do, Korea
Tel : +82-31-3236008,9
Fax : +82-31-3236010
www.ltalab.com

EUT/Model No.: AIM-1.0 Temp/Humi: 20 / 31
Test Mode : Operating mode(MID) Tested by: Kwon H C

Data: 1873 File: C:\Program Files (x86)\e3\1812-2.EM6 (1877)

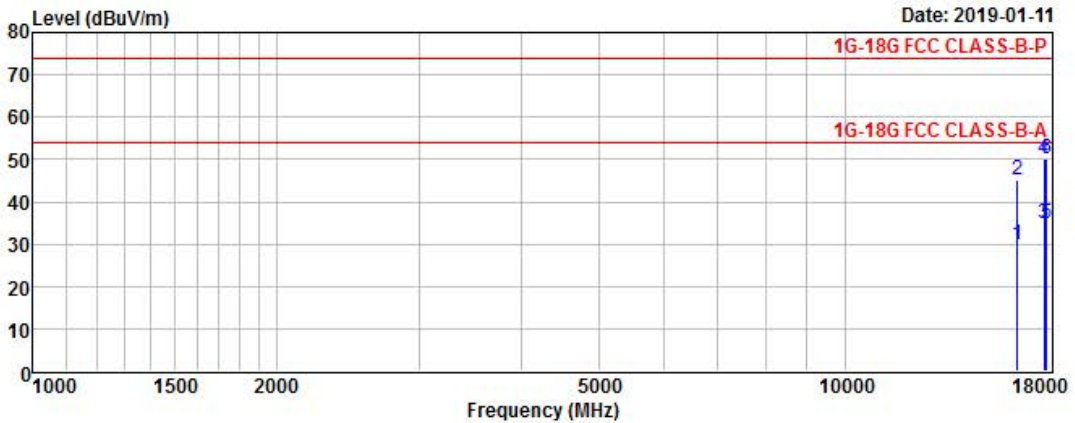

Freq	Reading	C.F	Result	Limit	Margin	Height	Angle	Polarity
MHz	dBuV	dB	QP dBuV/m	dBuV/m	dB	cm	deg	
16274.00	20.25	9.67	29.92	54.00	24.08	252	223	HORIZONTAL
16274.00	35.48	9.67	45.15	74.00	28.85	252	223	HORIZONTAL
17587.00	20.52	14.32	34.84	54.00	19.16	163	220	HORIZONTAL
17587.00	35.70	14.32	50.02	74.00	23.98	163	220	HORIZONTAL
17681.00	20.22	14.55	34.77	54.00	19.23	135	220	HORIZONTAL
17681.00	35.61	14.55	50.16	74.00	23.84	135	220	HORIZONTAL

Remarks: C.F (Correction Factor) = Antenna factor + Cable loss - Preamp gain



4, Songjuro 236Beon-gil, yanggi-myeon,
Yongin-si, Gyeonggi-do, Korea
Tel : +82-31-3236008,9
Fax : +82-31-3236010
www.ltalab.com

EUT/Model No.: AIM-1.0 Temp/Humi: 20 / 31
Test Mode : Operating mode(MID) Tested by: Kwon H C

Data: 1876 File: C:\Program Files (x86)\e3\1812-2.EM6 (1877)

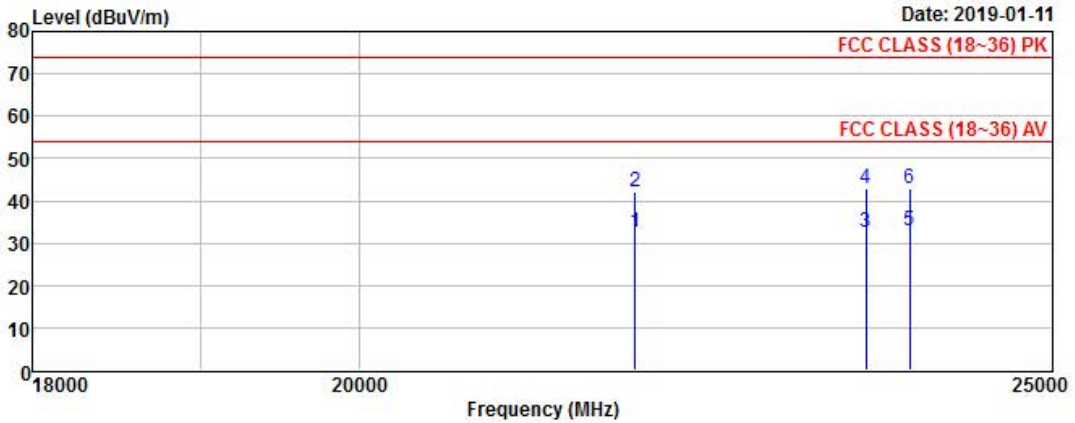

Freq	Reading	C.F	Result	Limit	Margin	Height	Angle	Polarity
MHz	dBuV	dB	QP dBuV/m	dBuV/m	dB	cm	deg	
21862.00	25.69	6.77	32.46	54.00	21.54	304	38	HORIZONTAL
21862.00	35.19	6.77	41.96	74.00	32.04	304	38	HORIZONTAL
23541.00	25.41	7.06	32.47	54.00	21.53	204	163	HORIZONTAL
23541.00	35.97	7.06	43.03	74.00	30.97	204	163	HORIZONTAL
23876.00	25.62	7.16	32.78	54.00	21.22	163	268	HORIZONTAL
23876.00	35.61	7.16	42.77	74.00	31.23	163	268	HORIZONTAL

Remarks: C.F (Correction Factor) = Antenna factor + Cable loss - Preamp gain

Bluetooth(HIGH) mode



4, Songjuro 236Beon-gil, yanggi-myeon,
Yongin-si, Gyeonggi-do, Korea
Tel : +82-31-3236008,9
Fax : +82-31-3236010
www.ltalab.com

EUT/Model No.: AIM-1.0 Temp/Humi: 20 / 31

Test Mode : Operating mode(HIGH) Tested by: Kwon H C

Data: 1874 File: C:\Program Files (x86)\e3\1812-2.EM6 (1877)

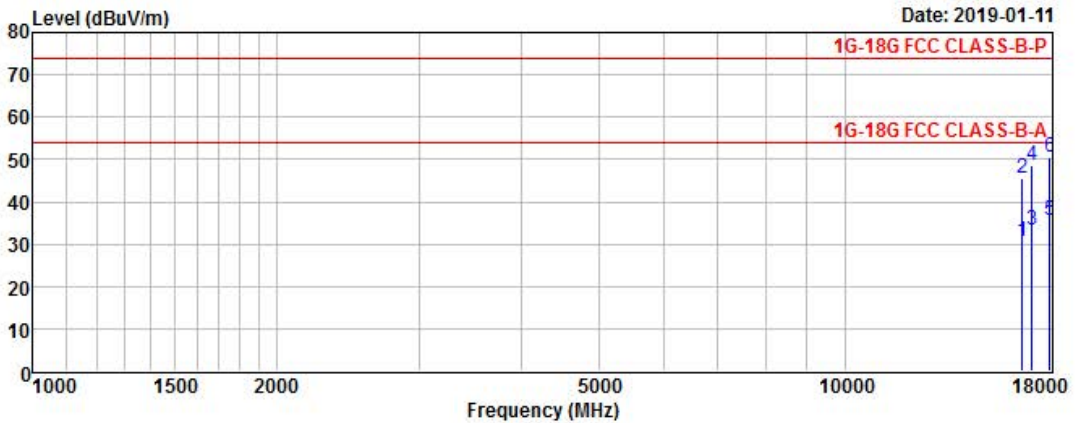

Freq	Reading	C.F	Result	Limit	Margin	Height	Angle	Polarity
MHz	dBuV	dB	QP dBuV/m	dBuV/m	dB	cm	deg	
16518.00	20.26	10.35	30.61	54.00	23.39	162	261	HORIZONTAL
16518.00	35.15	10.35	45.50	74.00	28.50	162	261	HORIZONTAL
16965.00	20.36	13.12	33.48	54.00	20.52	262	41	HORIZONTAL
16965.00	35.31	13.12	48.43	74.00	25.57	262	41	HORIZONTAL
17852.00	20.64	14.96	35.60	54.00	18.40	362	321	HORIZONTAL
17852.00	35.69	14.96	50.65	74.00	23.35	362	321	HORIZONTAL

Remarks: C.F (Correction Factor) = Antenna factor + Cable loss - Preamp gain



4, Songjuro 236Beon-gil, yanggi-myeon,
Yongin-si, Gyeonggi-do, Korea
Tel : +82-31-3236008,9
Fax : +82-31-3236010
www.ltalab.com

EUT/Model No.: AIM-1.0 Temp/Humi: 20 / 31

Test Mode : Operating mode(HIGH) Tested by: Kwon H C

Data: 1875 File: C:\Program Files (x86)\e3\1812-2.EM6 (1877)

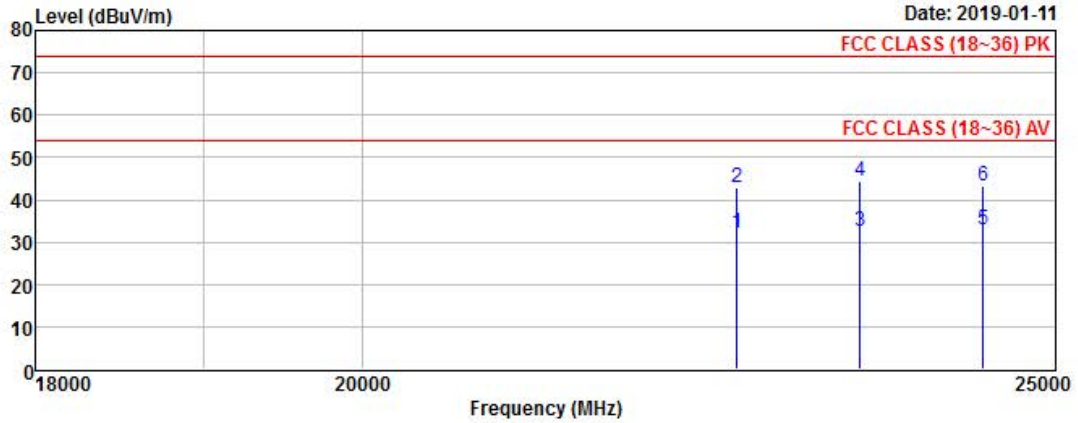

Freq	Reading	C.F	Result	Limit	Margin	Height	Angle	Polarity
MHz	dBuV	dB	QP dBuV/m	dBuV/m	dB	cm	deg	
22571.00	25.31	6.86	32.17	54.00	21.83	328	320	HORIZONTAL
22571.00	35.97	6.86	42.83	74.00	31.17	328	320	HORIZONTAL
23471.00	25.41	7.04	32.45	54.00	21.55	325	185	HORIZONTAL
23471.00	37.54	7.04	44.58	74.00	29.42	325	185	HORIZONTAL
24425.00	25.61	7.16	32.77	54.00	21.23	152	238	HORIZONTAL
24425.00	36.24	7.16	43.40	74.00	30.60	152	238	HORIZONTAL

Remarks: C.F (Correction Factor) = Antenna factor + Cable loss - Preamp gain

3.2.7 AC Conducted Emissions

Procedure:

The conducted emissions are measured in the shielded room with a spectrum analyzer in peak hold. While the measurement, EUT had its hopping function disabled at the middle channels in line with Section 15.31(m). Emissions closest to the limit are measured in the quasi-peak mode (QP) with the tuned receiver using a bandwidth of 9 kHz. The emissions are maximized further by cable manipulation and Exerciser operation. The highest emissions relative to the limit are listed.

Minimum Standard: FCC Part 15.207(a) / EN 55022

Measurement Data: Complies

Class B

Frequency Range	quasi-peak	Average
0.15 ~ 0.5	66 to 56 *	56 to 46 *
0.5 ~ 5	56	46
5 ~ 30	60	50

* Decreases with the logarithm of the frequency



4, Songjuro 236 Beon-gil, Yangji-myeon
 Cheoin-gu, Youngin-si, Gyeonggi-do
 449-822 Korea
 Tel:+82-31-3236008,9
 Fax:+82-31-3236010

EUT /Model No. : AIM-1.0	Phase : LINE
Test Mode : BLE mode (LOW)	Test Power : 120 / 60
Temp. / Humi. : 23'C / 34 % R.H.	Test Engineer : KWON H C

File: C:\Program Files\es3_ver9\temp\es3_ce_01822.EMI

Date: 2019-01-18

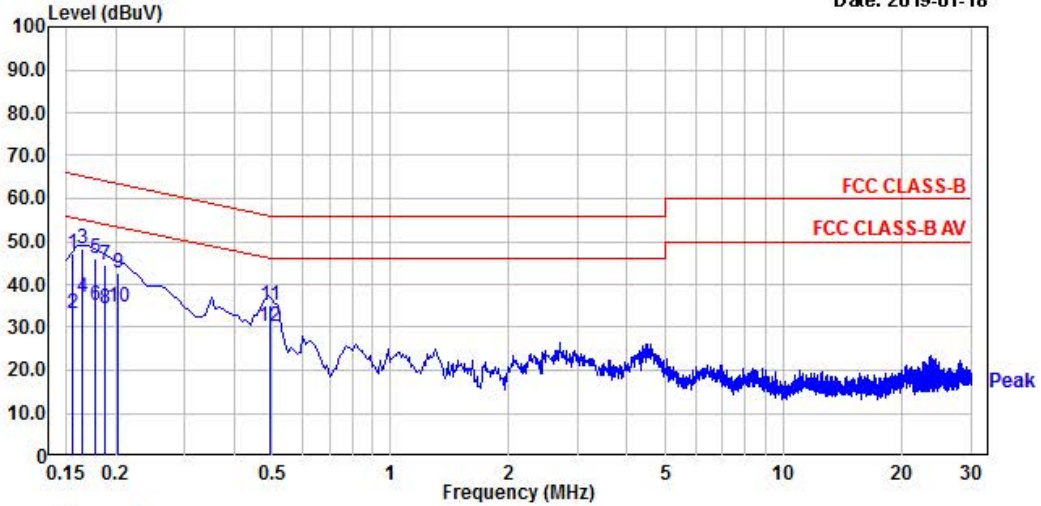

Trace: 1

Freq MHz	RD QP dBuV	RD AV dBuV	C.F dB	Result QP dBuV	Result AV dBuV	Limit QP dBuV	Limit AV dBuV	Margin QP dB	Margin AV dB
0.156	27.67	13.61	19.49	47.16	33.10	65.68	55.68	18.52	22.58
0.165	28.89	17.33	19.50	48.39	36.83	65.19	55.19	16.80	18.36
0.177	26.68	15.75	19.48	46.16	35.23	64.60	54.60	18.44	19.37
0.189	24.93	14.84	19.48	44.41	34.32	64.09	54.09	19.68	19.77
0.204	23.34	15.29	19.48	42.82	34.77	63.46	53.46	20.64	18.69
0.493	15.66	10.59	19.50	35.16	30.09	56.12	46.12	20.96	16.03

Remarks: C.F (Correction Factor) = Insertion loss + Cable loss + Pulse Limiter



4, Songjuro 236 Beon-gil, Yangji-myeon
 Cheoin-gu, Youngin-si, Gyeonggi-do
 449-822 Korea
 Tel:+82-31-3236008,9
 Fax:+82-31-3236010

EUT /Model No. : AIM-1.0	Phase : LINE
Test Mode : BLE mode (MID)	Test Power : 120 / 60
Temp. / Humi. : 23'C / 34 % R.H.	Test Engineer : KWON H C

File: C:\Program Files\es3_ver9\temp\es3_ce_01823.EMI

Date: 2019-01-18

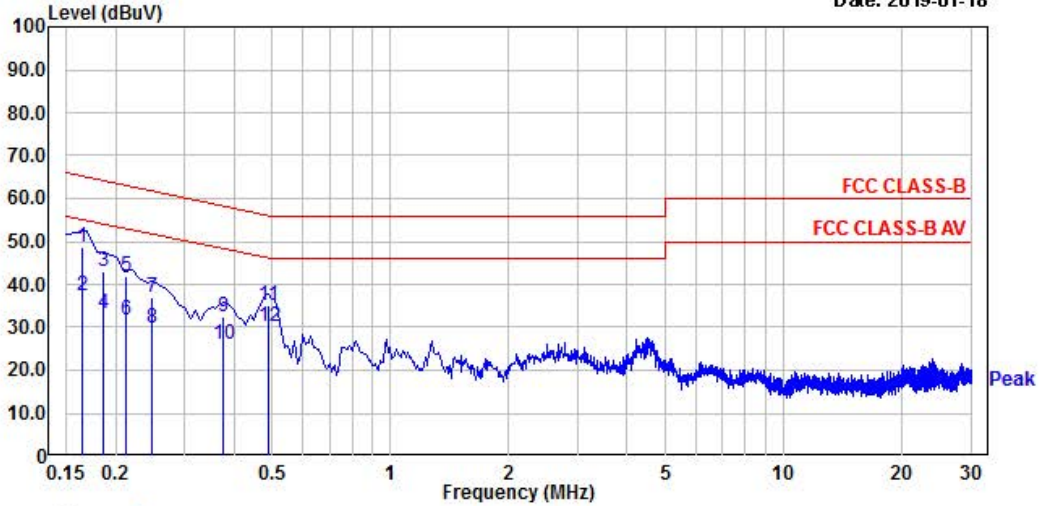

Trace: 1

Freq MHz	RD QP dBuV	RD AV dBuV	C.F dB	Result QP dBuV	Result AV dBuV	Limit QP dBuV	Limit AV dBuV	Margin QP dB	Margin AV dB
0.165	29.00	17.72	19.50	48.50	37.22	65.19	55.19	16.69	17.97
0.186	23.60	13.73	19.48	43.08	33.21	64.21	54.21	21.13	21.00
0.214	22.41	12.31	19.48	41.89	31.79	63.06	53.06	21.17	21.27
0.249	17.40	10.17	19.49	36.89	29.66	61.81	51.81	24.92	22.15
0.376	12.92	6.52	19.50	32.42	26.02	58.37	48.37	25.95	22.35
0.489	15.71	10.84	19.50	35.21	30.34	56.19	46.19	20.98	15.85

Remarks: C.F (Correction Factor) = Insertion loss + Cable loss + Pulse Limiter



4, Songjuro 236 Beon-gil, Yangji-myeon
 Cheoin-gu, Youngin-si, Gyeonggi-do
 449-822 Korea
 Tel:+82-31-3236008,9
 Fax:+82-31-3236010

EUT /Model No. : AIM-1.0	Phase : LINE
Test Mode : BLE mode (HIGH)	Test Power : 120 / 60
Temp. / Humi. : 23'C / 34 % R.H.	Test Engineer : KWON H C

File: C:\Program Files\es3_ver9\temp\es3_ce_01824.EMI

Date: 2019-01-18

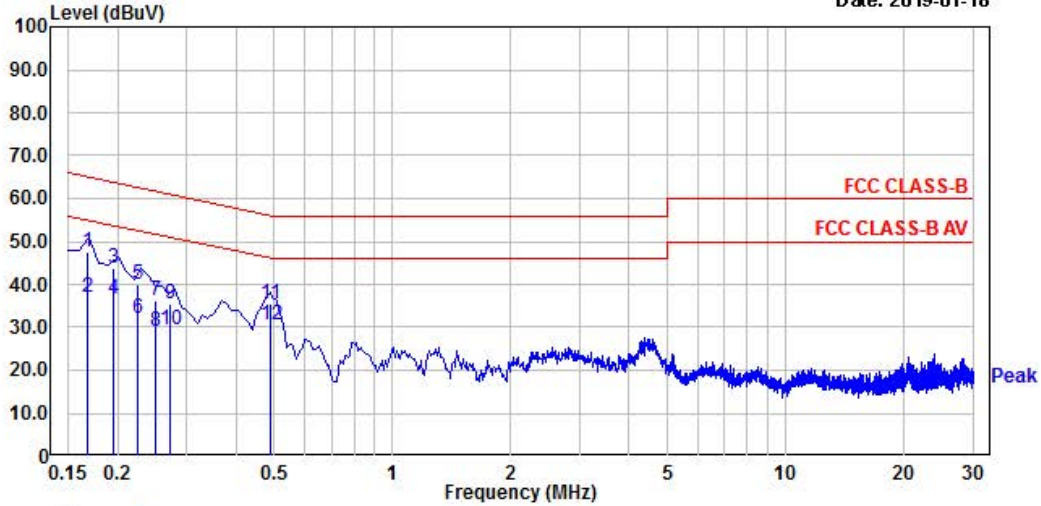

Trace: 1

Freq MHz	RD QP dBuV	RD AV dBuV	C.F dB	Result QP dBuV	Result AV dBuV	Limit QP dBuV	Limit AV dBuV	Margin QP dB	Margin AV dB
0.168	27.98	17.51	19.50	47.48	37.01	65.08	55.08	17.60	18.07
0.195	24.43	17.09	19.48	43.91	36.57	63.80	53.80	19.89	17.23
0.224	20.43	12.51	19.49	39.92	32.00	62.66	52.66	22.74	20.66
0.250	16.65	9.44	19.49	36.14	28.93	61.77	51.77	25.63	22.84
0.272	16.07	9.85	19.49	35.56	29.34	61.05	51.05	25.49	21.71
0.490	15.88	10.95	19.50	35.38	30.45	56.16	46.16	20.78	15.71

Remarks: C.F (Correction Factor) = Insertion loss + Cable loss + Pulse Limiter



4, Songjuro 236 Beon-gil, Yangji-myeon
 Cheoin-gu, Youngin-si, Gyeonggi-do
 449-822 Korea
 Tel:+82-31-3236008,9
 Fax:+82-31-3236010

EUT /Model No. : AIM-1.0	Phase : Neutral
Test Mode : BLE mode (LOW)	Test Power : 120 / 60
Temp. / Humi. : 23'C / 34 % R.H.	Test Engineer : KWON H C

File: C:\Program Files\es3_ver9\temp\es3_ce_01827.EMI

Date: 2019-01-18

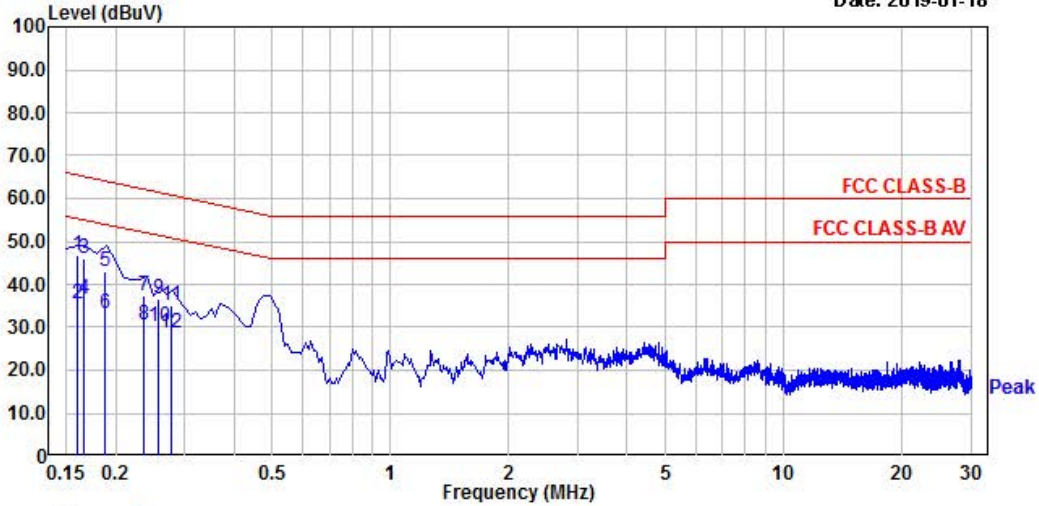

Trace: 1

Freq MHz	RD QP dBuV	RD AV dBuV	C.F dB	Result QP dBuV	Result AV dBuV	Limit QP dBuV	Limit AV dBuV	Margin QP dB	Margin AV dB
0.160	27.10	15.91	19.51	46.61	35.42	65.47	55.47	18.86	20.05
0.166	26.63	17.11	19.51	46.14	36.62	65.14	55.14	19.00	18.52
0.188	23.45	13.59	19.49	42.94	33.08	64.12	54.12	21.18	21.04
0.235	17.99	11.26	19.49	37.48	30.75	62.26	52.26	24.78	21.51
0.257	17.17	10.55	19.49	36.66	30.04	61.54	51.54	24.88	21.50
0.276	15.47	9.28	19.49	34.96	28.77	60.93	50.93	25.97	22.16

Remarks: C.F (Correction Factor) = Insertion loss + Cable loss + Pulse Limiter



4, Songjuro 236 Beon-gil, Yangji-myeon
 Cheoin-gu, Youngin-si, Gyeonggi-do
 449-822 Korea
 Tel:+82-31-3236008,9
 Fax:+82-31-3236010

EUT /Model No. : AIM-1.0	Phase : Neutral
Test Mode : BLE mode (MID)	Test Power : 120 / 60
Temp. / Humi. : 23'C / 34 % R.H.	Test Engineer : KWON H C

File: C:\Program Files\es3_ver9\temp\es3_ce_01826.EMI

Date: 2019-01-18

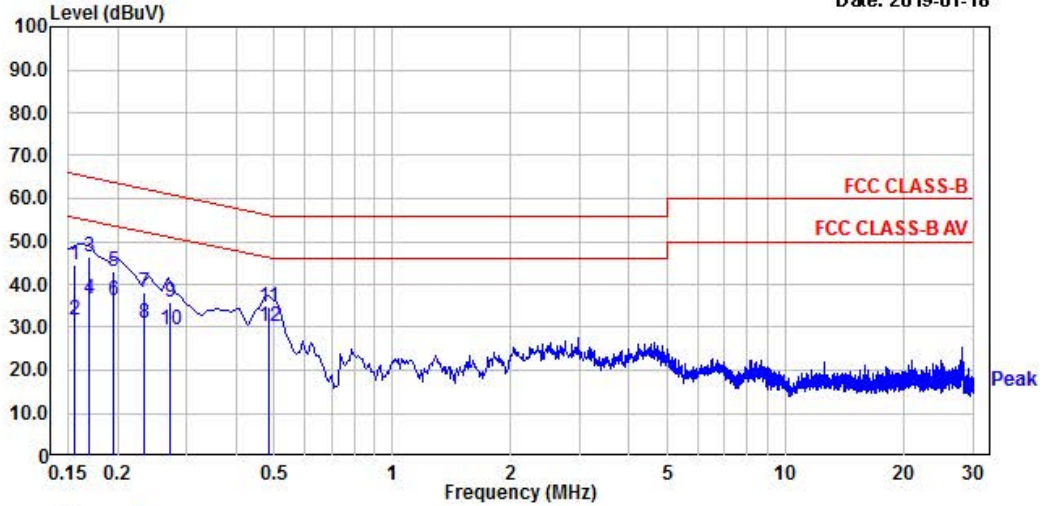

Trace: 1									
Freq	RD	RD	C.F	Result	Result	Limit	Limit	Margin	Margin
MHz	QP	AV	dB	QP	AV	QP	AV	QP	AV
	dBuV	dBuV		dBuV	dBuV	dBuV	dBuV	dB	dB
0.156	25.01	12.02	19.50	44.51	31.52	65.67	55.67	21.16	24.15
0.170	27.02	17.03	19.51	46.53	36.54	64.98	54.98	18.45	18.44
0.196	23.61	16.62	19.49	43.10	36.11	63.78	53.78	20.68	17.67
0.233	18.50	11.51	19.49	37.99	31.00	62.34	52.34	24.35	21.34
0.272	16.23	10.08	19.49	35.72	29.57	61.06	51.06	25.34	21.49
0.485	15.40	10.57	19.50	34.90	30.07	56.25	46.25	21.35	16.18

Remarks: C.F (Correction Factor) = Insertion loss + Cable loss + Pulse Limiter



4, Songjuro 236 Beon-gil, Yangji-myeon
 Cheoin-gu, Youngin-si, Gyeonggi-do
 449-822 Korea
 Tel:+82-31-3236008,9
 Fax:+82-31-3236010

EUT /Model No. : AIM-1.0	Phase : Neutral
Test Mode : BLE mode (HIGH)	Test Power : 120 / 60
Temp. / Humi. : 23'C / 34 % R.H.	Test Engineer : KWON H C

File: C:\Program Files\es3_ver9\temp\es3_ce_01825.EMI

Date: 2019-01-18

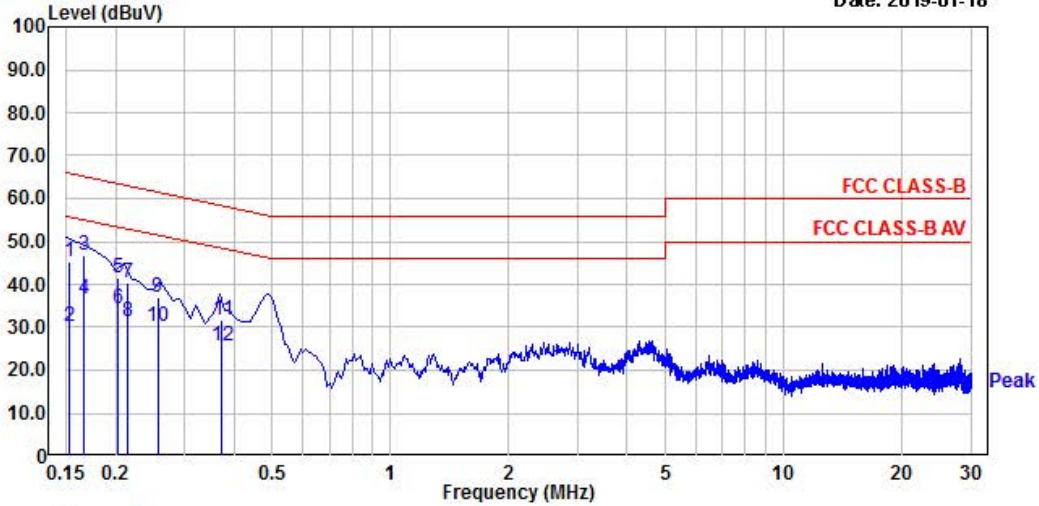

Trace: 1

Freq MHz	RD QP dBuV	RD AV dBuV	C.F dB	Result QP dBuV	Result AV dBuV	Limit QP dBuV	Limit AV dBuV	Margin QP dB	Margin AV dB
0.153	25.90	10.61	19.50	45.40	30.11	65.85	55.85	20.45	25.74
0.166	27.15	17.18	19.51	46.66	36.69	65.14	55.14	18.48	18.45
0.204	22.20	14.69	19.49	41.69	34.18	63.46	53.46	21.77	19.28
0.215	20.94	11.90	19.49	40.43	31.39	62.99	52.99	22.56	21.60
0.256	17.35	10.75	19.49	36.84	30.24	61.56	51.56	24.72	21.32
0.373	12.29	6.08	19.50	31.79	25.58	58.43	48.43	26.64	22.85

Remarks: C.F (Correction Factor) = Insertion loss + Cable loss + Pulse Limiter

APPENDIX
TEST EQUIPMENT USED FOR TESTS

	Use	Description	Model No.	Serial No.	Manufacturer	Interval	Last Cal. Date
1	■	Signal Analyzer (9 kHz ~ 30 GHz)	FSV30	100757	R&S	1 year	2018-09-06
2		SYNTHESIZED CW GENERATOR	83711B	US34490456	HP	1 year	2018-03-19
3		Attenuator (3 dB)	8491A	37822	HP	1 year	2018-09-06
4		Attenuator (10 dB)	8491A	63196	HP	1 year	2018-09-06
5	■	EMI Test Receiver (~7 GHz)	ESCI7	100722	R&S	1 year	2018-09-06
6	■	RF Amplifier (~1.3 GHz)	8447D OPT 010	2944A07684	HP	1 year	2018-09-06
7	■	RF Amplifier (1~26.5 GHz)	8449B	3008A02126	HP	1 year	2018-03-21
8	■	Horn Antenna (1~18 GHz)	3115	00114105	ETS	2 year	2018-08-04
9		DRG Horn (Small)	3116B	81109	ETS-Lindgren	2 year	2018-05-03
10	■	DRG Horn (Small)	3116B	133350	ETS-Lindgren	2 year	2018-05-03
11	■	TRILOG Antenna	VULB 9160	9160-3237	SCHWARZBECK	2 year	2017-04-17
13		DC Power Supply	6674A	3637A01657	Agilent	-	-
14	■	Power Meter	EPM-441A	GB32481702	HP	1 year	2018-03-20
15	■	Power Sensor	8481A	3318A94972	HP	1 year	2018-09-06
16		Audio Analyzer	8903B	3729A18901	HP	1 year	2018-09-06
17		Modulation Analyzer	8901B	3749A05878	HP	1 year	2018-09-06
18		TEMP & HUMIDITY Chamber	YJ-500	LTAS06041	JinYoung Tech	1 year	2018-09-06
19		Stop Watch	HS-3	812Q08R	CASIO	2 year	2018-03-21
20		LISN	KNW-407	8-1430-1	Kyoritsu	1 year	2018-09-06
21		Two-Lime V-Network	ESH3-Z5	893045/017	R&S	1 year	2018-03-20
22		Highpass Filter	WHKX1.5/15G-10SS	74	Wainwright Instruments	1 year	2018-03-20
23		Highpass Filter	WHKX3.0/18G-10SS	118	Wainwright Instruments	1 year	2018-03-20
24		OSP120 BASE UNIT	OSP120	101230	R&S	1 year	2018-03-21
25	■	Signal Generator(100 kHz ~ 40 GHz)	SMB100A	177621	R&S	1 year	2018-03-20
26		Vector Signal Generator(9kHz ~ 6 GHz)	SMBV100A	255081	R&S	1 year	2018-03-20
27		Signal Analyzer (10 Hz ~ 40 GHz)	FSV40	101367	R&S	1 year	2018-03-21
30	■	RF Cable	SUCOFLEX	-	Huber+suhner	-	-