

Introduction

The document is a guide for iBS05/iBS05G/iBS05H/iBS05T. To quickly verify it, please download INGICS iBS01 Tag Utility APP from below link(Android only):

<https://play.google.com/store/apps/details?id=com.ingics.tag.igstagconfig>



Overview

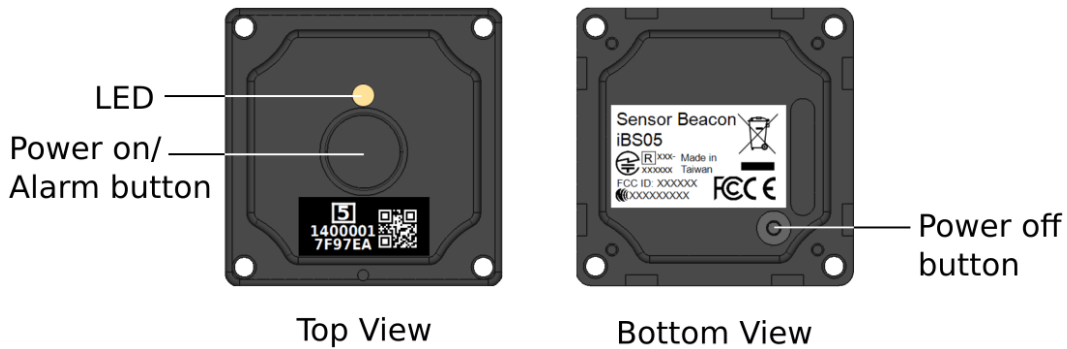

Operation

Basically, iBS05 will always transmit BLE payload in the configured time interval(by default, iBS05/05G is 5s and iBS05H/05T is 30s) in the background after power on. The transmitted BLE payload/message is then received and uploaded to the internet/cloud server by the beacon gateway, such as iGS01S or iGS03W/M/E. Besides background transmission, button or sensor status change will also trigger an immediate BLE transmission for monitoring the sensor in real time.

Power on

iBS05 is in standby mode at shipping. You can power on it by pressing the front button. The LED will flash "Red" to indicate it is powered on. After power on, the button becomes the alarm button.

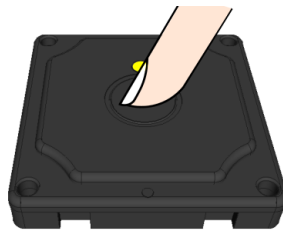

Power off

When necessary, users can power off iBS05 by applying a pencil with a blunt tip to the rubber button on the bottom side. The LED will flash "Orange" to indicate it is powered off and entering the standby mode.

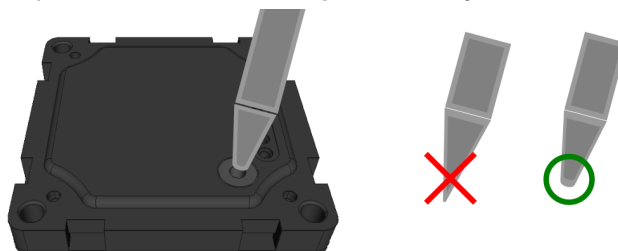

Alarm Button

After power on, the front button acts as an alarm button. As pressing the button, the LED will light up “green” and trigger an immediate BLE transmission with the button activation event. As the back end server received this status change, it can be used as a warning or alarming.

LED

Power on(Start of Config mode)	Red blinking
End of Config mode	Green blinking
Alarm Button	Green on when pressed
Battery inserted/Power off	Orange blinking

Working Mode

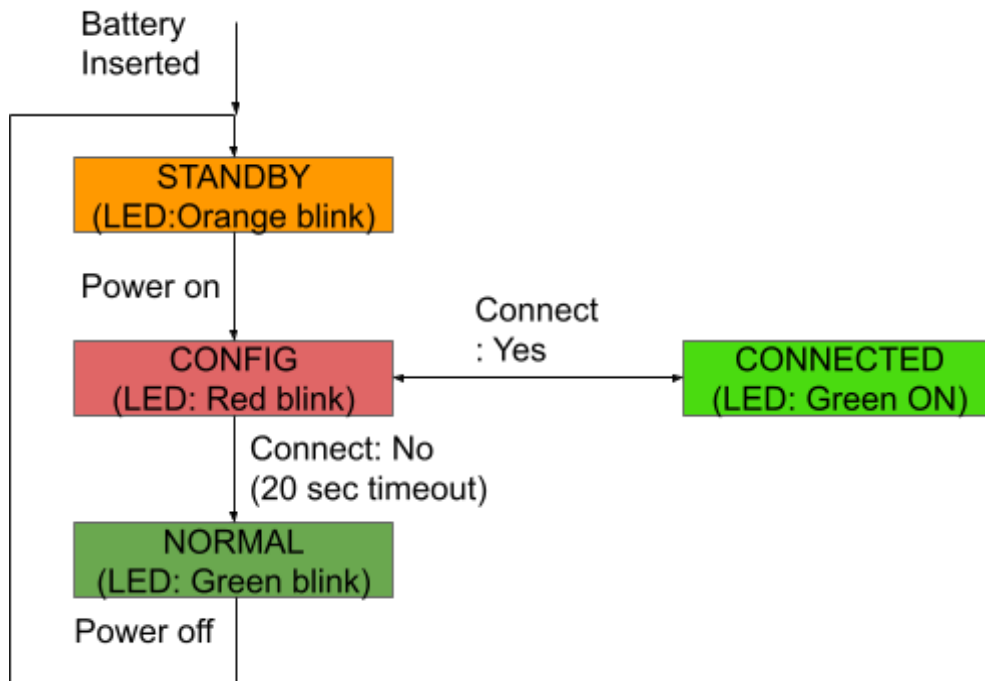

Hall Sensor (iBS05H)

Inside iBS05H, there is a hall sensor that can be used to detect if a magnet is in range or not. Depending on the strength of the magnet, the active range is around 0.5cm~1.5cm. The sensor position is marked on the enclosure. A typical usage is to put an iBS05 and magnet on the door(or window) and door frame. When they are close to the active range, iBS05 will trigger an immediate BLE transmission. On the other hand, when they are far away from a close state, it will also trigger an immediate BLE transmission.

Accelerometer (iBS05G)

The accelerometer will be active when it's status changes. It includes from motion to still or from still to motion. An immediate BLE transmission with status change will be triggered as active.

Temperature Sensor (iBS05T)

iBS05T is always monitoring the environment temperature and

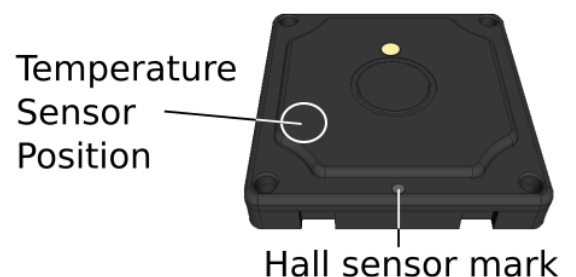

INGICS TECHNOLOGY

transmitting the temperature value in the configured time interval .

Verifying

1. Power on iBS05
2. Open iBS01 Tag Utility APP and Press "START SCAN".
3. Wait for a while, you should see the BLE payload of iBS05 received by the APP.

Below is an explanation of the payload shown in the APP.

Received RSSI

Temperature

Sensor Status

00: no active
01: button pressed
02: motion detected
40: magnet in range

Battery Voltage

Battery

Level

iBS05 uses a CR2032 coin battery as the power source. It consumes only a little power and keeps working for a long time. Below is a suggestion for translating the battery voltage to the remaining capacity at room temperature.

Capacity	Voltage
High	>2.9V
Middle	>2.8V
Low	>2.65V
Change battery	<=2.65V

Remember, a proper filtering on the voltage is necessary. When iBS05 works in a low temperature environment, the battery voltage will be lower. For example, in -20 ° C, the voltage should be adjusted 0.1V~0.2V lower.

Change Battery

1. Remove the 4 screws on the backside and open the bottom cover.
2. It is very important that without enclosure protection, **the internal of iBS05 is sensitive to electrostatics. Before opening the bottom cover, please make sure the proper procedure is executed to avoid any electrostatic damage to iBS05.**
3. Change a new battery
4. Before closing the bottom cover, please make sure the O-ring is in the proper position to keep iBS05 waterproof.
5. Fix the screws.



Configuration

When powered on, iBS05 will be in configuration mode for 20 sec. Users can use iBS01 Tag Utility to scan and connect iBS05 to configure the transmit power and ADV(advertising) interval.

Steps

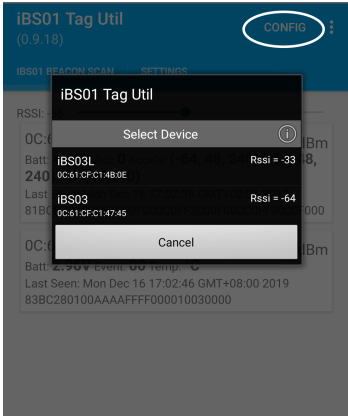
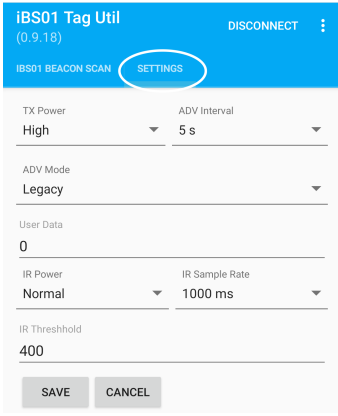
<p>1. Power on iBS05 (if iBS05 is already powered on, please power off it first then power on again)</p>	<p>2. Press the CONFIG icon on the up-right corner of the utility within 20 secs. Select iBS05 for configuration.</p>	<p>3. In the SETTING page, you can configure TX power and ADV interval. After configuring, press SAVE and DISCONNECT for the parameters to take effect.</p>
		

Parameters

In iBS05, there are two parameters that can be configured.

- TX power: +4 dBm ~ -20dBm.
- ADV Interval: From 100 ms~60 min.

Waste Electrical and Electronic Equipment Recycling

Our product is compliant with the WEEE directive for re-use/recovery/recycling. This cross-out wheeled-bin symbol is a reminder that this product should not be treated as household waste. Instead hand it over to the appropriate collection point for the recycling of electrical and electronic equipment in accordance with local environmental regulations for waste disposal.

Since our product is not sold directly to the end user and generally it is a part of our customer's solution, our customer is recognized as a professional seller. Our customer has the responsibility to comply with the requirement of the directive too. To help our customers, when necessary, we will provide a WEEE compliant assessment report for registering and communicating with the local authorities and recycling agency.



Certification

Japan MIC Regulatory

FCC Regulatory
2AH2IIBS05

NCC Regulatory

Statement

Federal Communication Commission Interference Statement

This equipment has been tested and found to comply with the limits for a Class B digital device, pursuant to Part 15 of the FCC Rules. These limits are designed to provide reasonable protection against harmful interference in a residential installation.

This equipment generates, uses and can radiate radio frequency energy and, if not installed and used in accordance with the instructions, may cause harmful interference to radio communications. However, there is no guarantee that interference will not occur in a particular installation. If this equipment does cause harmful interference to radio or television reception, which can be determined by turning the equipment off and on, the user is encouraged to try to correct the interference by one of the following measures:

- . Reorient or relocate the receiving antenna.
- . Increase the separation between the equipment and receiver.
- . Connect the equipment into an outlet on a circuit different from that to which the receiver is connected.
- . Consult the dealer or an experienced radio/TV technician for help.

FCC Caution: To assure continued compliance, any changes or modifications not expressly approved by the party responsible for compliance could void the user's authority to operate this equipment. (Example - use only shielded interface cables when connecting to computer or peripheral devices).

FCC Radiation Exposure Statement This equipment complies with FCC RF radiation exposure limits set forth for an uncontrolled environment. This equipment should be installed and operated with a minimum distance of 0.5 centimeters between the radiator and your body.

This transmitter must not be co-located or operating in conjunction with any other antenna or transmitter. The antennas used for this transmitter must be installed to provide a separation distance of at least 0.5 cm from all persons and must not be co-located or operating in conjunction with any other antenna or transmitter.

This device complies with Part 15 of the FCC Rules. Operation is subject to the following two conditions: (1) This device may not cause harmful interference, and (2) This device must accept any interference received, including interference that may cause undesired operation.

Industry Canada Statement

This device complies with Industry Canada licence-exempt RSS standard. Operation is subject to the following two conditions: (1) this device may not cause interference, and (2) this device must accept any interference, including interference that may cause undesired operation of the device.

Le présent appareil est conforme aux CNR d'Industrie Canada applicables aux appareils radio exempts de licence.

L'exploitation est autorisée aux deux conditions suivantes : (1) l'appareil ne doit pas produire de brouillage, et (2) l'utilisateur de l'appareil doit accepter tout brouillage radioélectrique subi, même si le brouillage est susceptible d'en compromettre le fonctionnement.

IC Radiation Exposure Statement

This equipment complies with IC RSS-102 radiation exposure limit set forth for an uncontrolled environment. This equipment should be installed and operated with minimum distance 0.5 cm between the radiator and your body.

Cet équipement est conforme aux CNR-102 d'Industrie Canada. Cet équipement doit être installé et utilisé avec une distance minimale de 0.5 centimètres entre le radiateur et votre corps. Cet émetteur ne doit pas être co-localisées ou opérant en conjonction avec autre antenne ou émetteur. Les antennes utilisées pour cet émetteur doivent être installés et fournir une distance de séparation d'au moins 0.5 centimètre de toute personne et doit pas être co-située ni fonctionner en conjonction avec une autre antenne ou émetteur.

NCC 警語

「取得審驗證明之低功率射頻器材，非經核准，公司、商號或使用者均不得擅自變更頻率、加大功率或變更原設計之特性及功能。低功率射頻器材之使用不得影響飛航安全及干擾合法通信；經發現有干擾現象時，應立即停用，並改善至無干擾時方得繼續使用。前述合法通信，指依電信管理法規定作業之無線電通信。低功率射頻器材須忍受合法通信或工業、科學及醫療用電波輻射性電機設備之干擾。」

Revision History

DATE	REVISION	CHANGES
May 30, 2021	0a	Initial release
June 2, 2021	0b	Add Waste Electrical and Electronic Equipment Recycling section for appropriate recycling the equipment
Aug 2, 2021	0c	Fix typo, modify LED section, and add Working mode section