



# TEST REPORT

No. I18D00082-EMC01

*For*

**Client : Shanghai Sunmi Technology  
Co.,Ltd.**

**Production: Smart POS system**

**Model Name : W6900**

**Hardware Version: V1.1**

**Software Version: B0451\_C1BOM\_SMT\_V1.0.1\_2017**

**1225**

**FCC ID: 2AH25W6900**

**Issued date: 2018-06-01**

**Note:**

The test results in this test report relate only to the devices specified in this report. This report shall not be reproduced except in full without the written approval of ECIT Shanghai.

**Test Laboratory:**

ECIT Shanghai, East China Institute of Telecommunications

Add: 7F, G Area, No.668, Beijing East Road, Huangpu District, Shanghai, P. R. China

Tel: (+86)-021-63843300, E-Mail: [welcome@ecit.org.cn](mailto:welcome@ecit.org.cn)

### Revision Version

| Report Number   | Revision | Date       | Memo                            |
|-----------------|----------|------------|---------------------------------|
| I18D00082-EMC01 | 00       | 2018-06-01 | Initial creation of test report |

## CONTENTS

|   |           |
|---|-----------|
| <b>1. TEST LABORATORY .....</b>   | <b>5</b>  |
| <b>1.1. TESTING LOCATION .....</b>                                      | <b>5</b>  |
| <b>1.2. TESTING ENVIRONMENT .....</b>                                   | <b>5</b>  |
| <b>1.3. PROJECT DATA.....</b>   | <b>5</b>  |
| <b>1.4. SIGNATURE .....</b>   | <b>5</b>  |
| <b>2. CLIENT INFORMATION .....</b>                                      | <b>6</b>  |
| <b>2.1. APPLICANT INFORMATION .....</b>                                 | <b>6</b>  |
| <b>2.2. MANUFACTURER INFORMATION .....</b>                              | <b>6</b>  |
| <b>3. EQUIPMENT UNDER TEST (EUT) AND ANCILLARY EQUIPMENT (AE) .....</b> | <b>7</b>  |
| <b>3.1. ABOUT EUT .....</b>   | <b>7</b>  |
| <b>3.2. INTERNAL IDENTIFICATION OF EUT USED DURING THE TEST .....</b>   | <b>7</b>  |
| <b>3.3. INTERNAL IDENTIFICATION OF AE USED DURING THE TEST .....</b>    | <b>7</b>  |
| <b>4. REFERENCE DOCUMENTS.....</b>                                      | <b>8</b>  |
| <b>4.1. REFERENCE DOCUMENTS FOR TESTING .....</b>                       | <b>8</b>  |
| <b>5. TEST RESULTS.....</b>   | <b>9</b>  |
| <b>5.1. SUMMARY OF TEST RESULTS.....</b>                                | <b>9</b>  |
| <b>5.2. STATEMENTS.....</b>   | <b>9</b>  |
| <b>6. TEST EQUIPMENTS UTILIZED.....</b>                                 | <b>10</b> |
| <b>6.1 RADIATED EMISSION EQUIPMENTS LIST .....</b>                      | <b>10</b> |
| <b>6.2 AC CONDUCTED EMISSION EQUIPMENTS LIST.....</b>                   | <b>10</b> |
| <b>7. SYSTEM CONFIGURATION DURING TEST .....</b>                        | <b>11</b> |
| <b>7.1 TEST MODE.....</b>   | <b>11</b> |
| <b>7.2 CONNECTION DIAGRAM OF TEST SYSTEM.....</b>                       | <b>11</b> |
| <b>8. MEASUREMENT RESULTS .....</b>                                     | <b>12</b> |
| <b>8.1 RADIATED EMISSION 30MHZ-12.75GHZ .....</b>                       | <b>12</b> |

**8.2 AC CONDUCTED EMISSION..... 16**

## 1. Test Laboratory

### 1.1. Testing Location

Company Name: ECIT Shanghai, East China Institute of Telecommunications  
Address: 7F, G Area, No. 668, Beijing East Road, Huangpu District, Shanghai,  
P. R. China  
Postal Code: 200001  
Telephone: 86-21-63843300  
Fax: 86-21-63843301  
FCC registration No: 489729

### 1.2. Testing Environment

Normal Temperature: 15-35°C  
Relative Humidity: 30-60%RH

### 1.3. Project data

Project Leader: Yu Anlu  
Testing Start Date: 2018-05-09  
Testing End Date: 2018-05-23

### 1.4. Signature



Qin Yabin

(Prepared this test report)



You Jinjun

(Reviewed this test report)

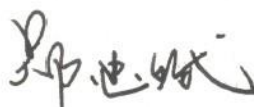

Zheng Zhongbin

Director of the laboratory  
(Approved this test report)

## 2. Client Information

### 2.1. Applicant Information

Company Name: Shanghai Sunmi Technology Co.,Ltd.  
Address: Room 505, KIC Plaza, No.388 Song Hu Road, Yang Pu District,  
Shanghai, China  
Tel: 18721763396  
Postcode: 200433

### 2.2. Manufacturer Information

Company Name: Shanghai Sunmi Technology Co.,Ltd.  
Address: Room 505, KIC Plaza, No.388 Song Hu Road, Yang Pu District,  
Shanghai, China  
Tel: 18721763396  
Postcode: 200433

### 3. Equipment under Test (EUT) and Ancillary Equipment (AE)

#### 3.1. About EUT

|                                   |                                       |
|-----------------------------------|---------------------------------------|
| ProductName                       | Smart POS system                      |
| Model name                        | W6900                                 |
| GSM Frequency Band                | GSM850/GSM900/GSM1800/GSM1900         |
| CDMA Frequency Band               | CDMA BC0/BC1                          |
| UMTS Frequency Band               | WCDMA Band I / II /IV /V              |
| LTE Frequency Band                | LTE2/4/7/17/28                        |
| Additional Communication Function | BT3.0,4.0; WIFI 802.11a,b,g,n;GPS;NFC |

#### 3.2. Internal Identification of EUT used during the test

| EUT ID* | SN or IMEI     | HW Version | SW Version                              | Date of receipt |
|---------|----------------|------------|---|-----------------|
| N04     | A100005F400057 | V1.1       | B0451_C1BOM_S<br>MT_V1.0.1_201712<br>25 | 2018-05-09      |

\*EUT ID: is used to identify the test sample in the lab internally.

#### 3.3. Internal Identification of AE used during the test

| AE ID* | Description | Model               | SN                           |
|--------|-------------|---------------------|------------------------------|
| UA06   | USB cable   | NA                  | NA                           |
| CA04   | Adapter     | TPA-46050200UU      | NA                           |
| BB04   | Battery     | SM-INR18650M26-1S2P | NA                           |
| BA04   | Battery     | SM-18650B4-1S2P     | NA                           |
| AE1    | Notebook PC | ThinkPad Edge E430  | 0B65911                      |
| AE2    | LAN Cable   | NA                  | NA                           |
| AE3    | VGA Cable   | NA                  | NA                           |
| AE4    | RS232 Cable | NA                  | NA                           |
| AE5    | Keyboard    | KB212-B             | CN-0Y88XT-65890-12I-005Q-A00 |
| AE6    | Mouse       | MS111-P             | CN-011D3V-71581-19J-1A64     |
| AE7    | Monitor     | Dell E1709Wc        | NA                           |

\*AE ID: is used to identify the test sample in the lab internally.

## 4. Reference Documents

### 4.1. Reference Documents for testing

The following documents listed in this section are referred for testing.

| Reference                 | Title   | Version         |
|---------------------------|---|-----------------|
| FCC Part 15,<br>Subpart B | Radio frequency devices   | 10-1-10 Edition |
| ANSI C63.4                | Method of Measurement of Radio-Noise Emissions from<br>Low-Voltage Electrical and Electronic Equipment in the<br>Range of 9 kHz to 40 GHz | 2014            |



## 5. Test Results

### 5.1. Summary of Test Results

| Items | Test List          | Clause in FCC rules | Verdict |
|-------|--------------------|---------------------|---------|
| 1     | Radiated Emission  | 15.109(a)           | Pass    |
| 2     | Conducted Emission | 15.107(a)           | Pass    |

### 5.2. Statements

The W6900, manufactured by Shanghai Sunmi Technology Co.,Ltd. Is a new product for testing. ECIT only performed test cases which identified with Pass/Fail/Inc result in section 5.1.

ECIT has verified that the compliance of the tested device specified in section 3 of this test report is successfully evaluated according to the procedure and test methods as defined in type certification requirement listed in section 4 of this test report.

## 6. Test Equipments Utilized

### 6.1 Radiated Emission Equipments list

| No. | Name                          | Type        | Series Number | Producer    | Cal. Date  | Cal. interval |
|-----|-------------------------------|-------------|---------------|-------------|------------|---------------|
| 1   | Universal Radio Communication | CMU200      | 123126        | R&S         | 2018-05-11 | 1 Year        |
| 2   | Test Receiver                 | ESU40       | 100307        | R&S         | 2018-05-11 | 1 Year        |
| 3   | Trilog Antenna                | VULB9163    | VULB9163-515  | Schwarzbeck | 2017-02-25 | 3 Year        |
| 4   | Double Ridged Guide           | ETS-3117    | 00135885      | ETS         | 2017-01-11 | 3 Year        |
| 5   | EMI Test Software             | EMC32 V9.15 | NA            | R&S         | NA         | NA            |

### 6.2 AC Conducted Emission Equipments list

| No. | Name              | Type        | Series Number | Producer | Cal. Date  | Cal. interval |
|-----|-------------------|-------------|---------------|----------|------------|---------------|
| 1   | Universal Radio   | CMU200      | 123123        | R&S      | 2018-05-11 | 1 Year        |
| 2   | Test Receiver     | ESCI        | 101235        | R&S      | 2018-05-11 | 1 Year        |
| 3   | 2-Line V-Network  | ENV216      | 101380        | R&S      | 2018-05-11 | 1 Year        |
| 4   | EMI Test Software | EMC32 V9.15 | NA            | R&S      | NA         | NA            |

## 7. System Configuration during Test

### 7.1 Test Mode

| Test Item   | Function Type  |
|---|--|
| Radiated emission   | Mode 1:Charge mode+CA04+BA04<Figure 1><br>Mode 2:Charge mode+CA04+BB04<Figure 1><br>Mode 3:Data link mode <Figure 2> |
| AC Conducted emission   | Mode 1:Charge mode+CA04+BA04<Figure 1><br>Mode 2:Charge mode+CA04+BB04<Figure 1><br>Mode 3:Data link mode <Figure 2> |
| Remark:<br>1. All test modes are performed, only the worst cases test data are recorded in this report. |  |

### 7.2 Connection Diagram of Test System

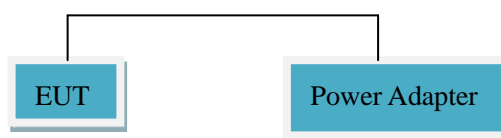

<Figure 1>

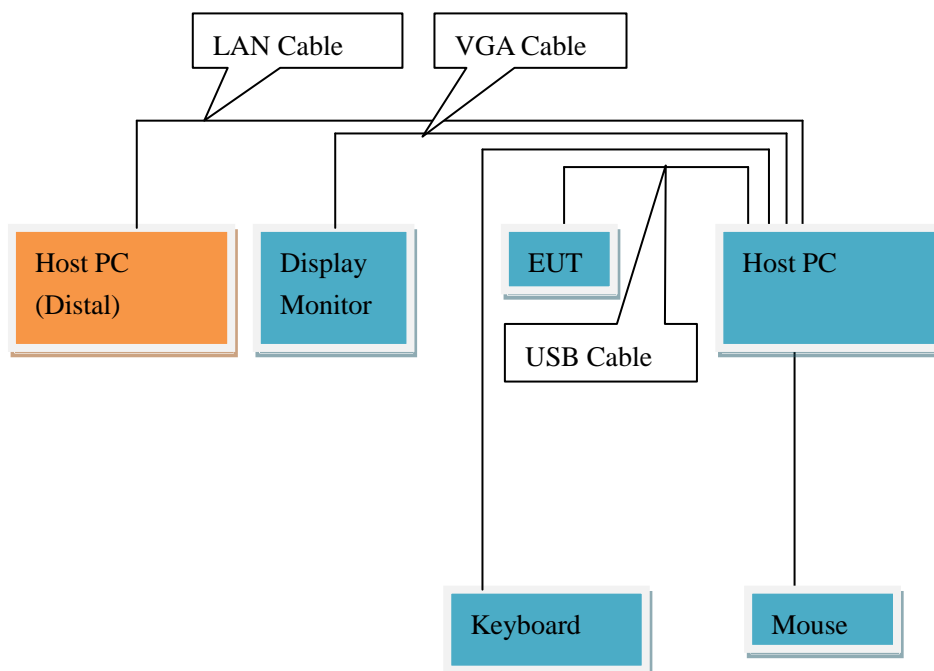

<Figure 2>

## 8. Measurement Results

Only the worst test result was shown in this report.

### 8.1 Radiated Emission 30MHz-12.75GHz

#### Method of Measurement

For 30-1000MHz, the EUT was placed on the top of a rotating 0.8-m table above the ground at a semi-anechoic chamber. The distance between the EUT and the received antenna was 3 meters. The table was rotated 360 degree and the received antenna mounted on a variable-height antenna tower was varied from 1m to 4m to find the maximum value of the field strength. Both horizontal and vertical polarizations of the antenna were set during the measurement. Tested in accordance with the procedures of ANSI C63.4-2014, section 8.3.

For 1000-12750MHz, The maximal emission value was acquired by adjusting the antenna height, The table was rotated 360 degree to determine the maximum value of the field strength. Both horizontal and vertical polarizations of the antenna were set during the measurement.

#### Limits for Radiated Emission at a measuring distance of 3m

| Frequency Range (MHz) | Quasi-Peak (dBuV/m) |
|-----------------------|---------------------|
| 30-88                 | 40                  |
| 88-216                | 43.5                |
| 216-960               | 46                  |
| Above 960             | 54                  |

| Frequency Range (MHz) | Peak (dBuV/m) | Average (dBuV/m) |
|-----------------------|---------------|------------------|
| Above 1000            | 74            | 54               |

#### Test conditions

| Frequency Range (MHz) | RBW/VBW       | Sweep Time (s) |
|-----------------------|---------------|----------------|
| 30-1000               | 120KHz/300KHz | Auto           |
| 1000-18000            | 1MHz/3MHz     | Auto           |

#### Uncertainty Measurement

The measurement uncertainty is 5.48dB (30 MHz -1000MHz) and 5.20dB (1000MHz-18000MHz) (k=2).

## Test Results

Mode 3: Data link mode<Figure 2>

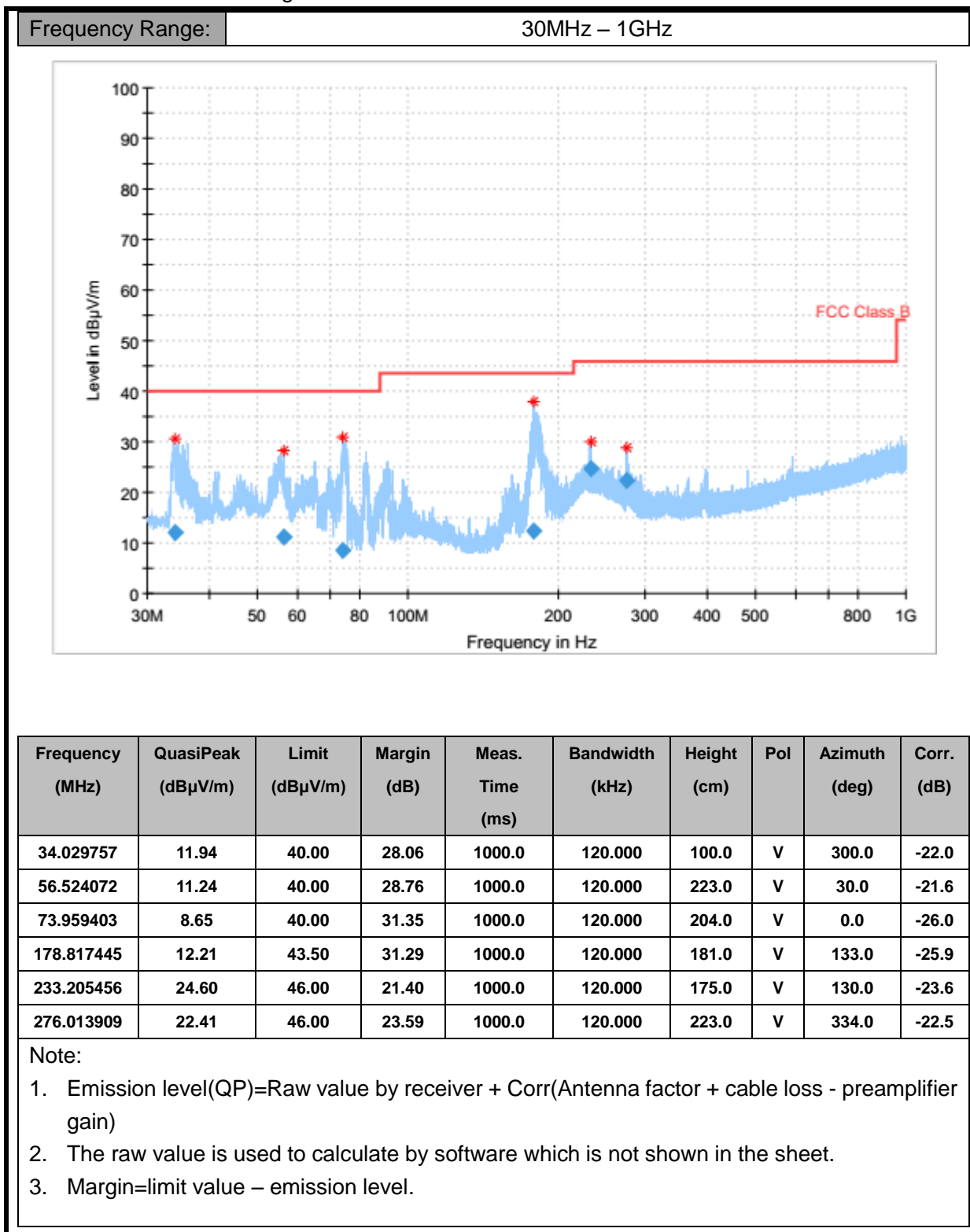

Mode 1: Charge mode+CA04+BA04<Figure1>

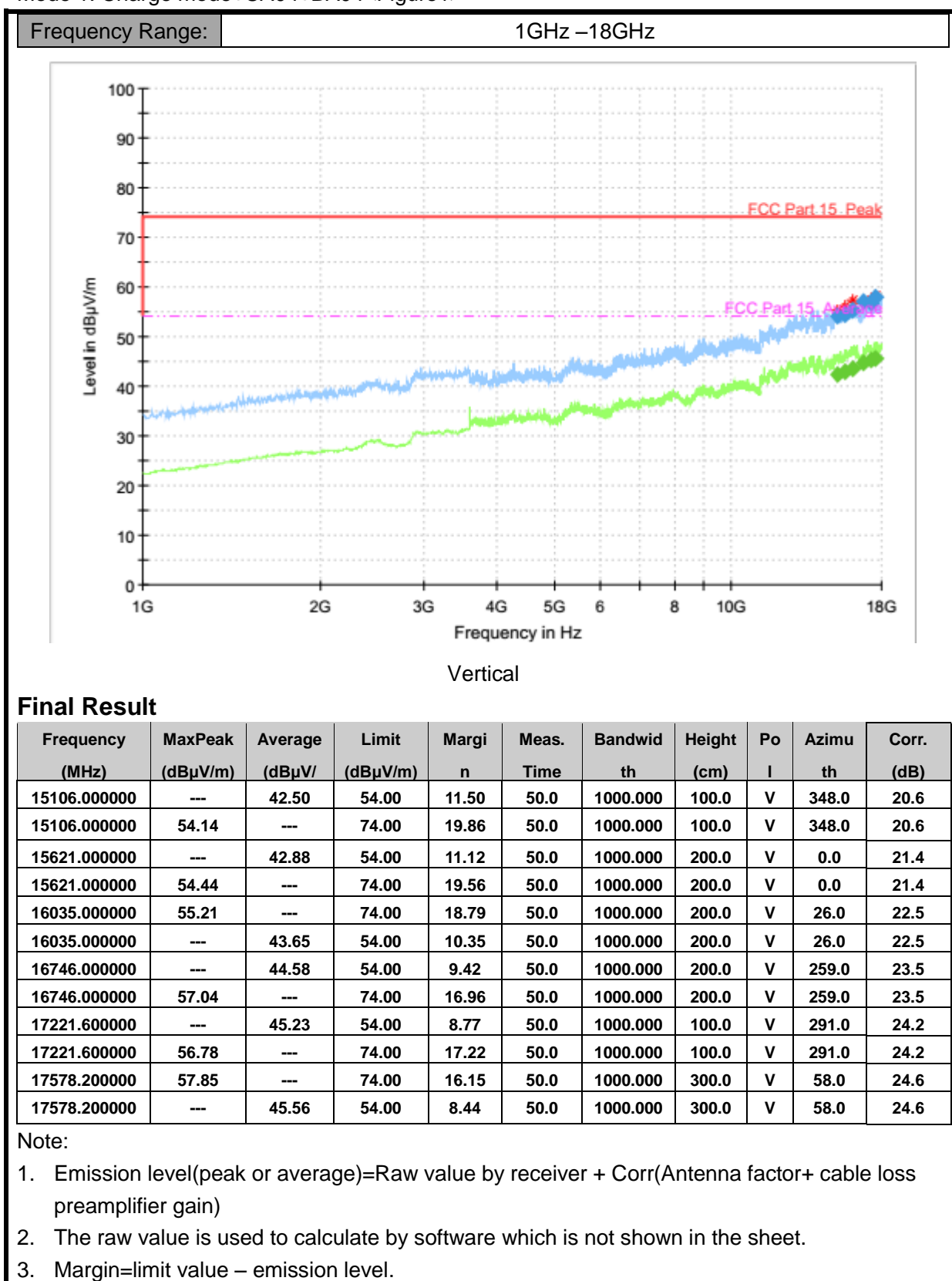

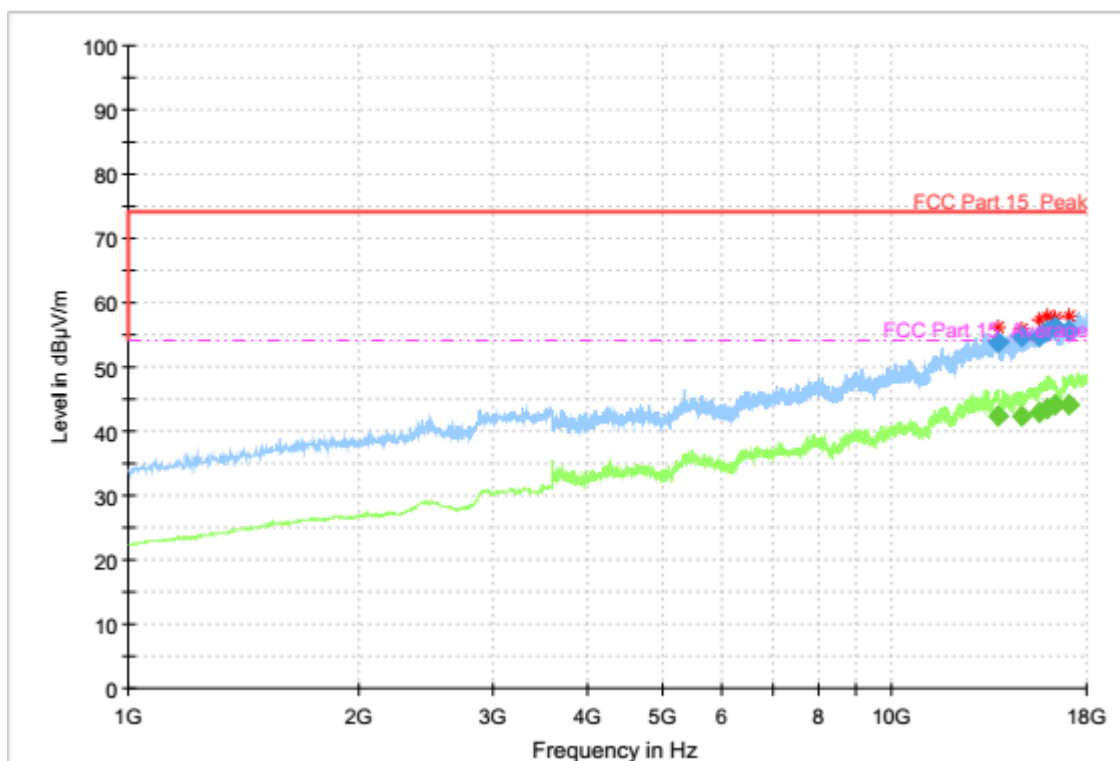

Horizontal

### Final Result

| Frequency (MHz) | MaxPeak (dBµV/m) | Average (dBµV/m) | Limit (dBµV/m) | Margin (dB) | Meas. Time | Bandwidth h | Heigh t | Po l | Azimuth (deg) | Corr. (dB) |
|-----------------|------------------|------------------|----------------|-------------|------------|-------------|---------|------|---------------|------------|
| 13767.600000    | 53.87            | ---              | 74.00          | 20.13       | 50.0       | 1000.000    | 400.0   | H    | 0.0           | 18.8       |
| 13767.600000    | ---              | 42.21            | 54.00          | 11.79       | 50.0       | 1000.000    | 400.0   | H    | 0.0           | 18.8       |
| 14818.600000    | ---              | 42.33            | 54.00          | 11.67       | 50.0       | 1000.000    | 400.0   | H    | 13.0          | 20.0       |
| 14818.600000    | 54.84            | ---              | 74.00          | 19.16       | 50.0       | 1000.000    | 400.0   | H    | 13.0          | 20.0       |
| 15646.200000    | 54.75            | ---              | 74.00          | 19.25       | 50.0       | 1000.000    | 300.0   | H    | 0.0           | 21.5       |
| 15646.200000    | ---              | 42.94            | 54.00          | 11.06       | 50.0       | 1000.000    | 300.0   | H    | 0.0           | 21.5       |
| 16007.800000    | 55.70            | ---              | 74.00          | 18.30       | 50.0       | 1000.000    | 199.0   | H    | 238.0         | 22.4       |
| 16007.800000    | ---              | 43.44            | 54.00          | 10.56       | 50.0       | 1000.000    | 199.0   | H    | 238.0         | 22.4       |
| 16358.800000    | ---              | 44.25            | 54.00          | 9.75        | 50.0       | 1000.000    | 199.0   | H    | 226.0         | 22.9       |
| 16358.800000    | 56.29            | ---              | 74.00          | 17.71       | 50.0       | 1000.000    | 199.0   | H    | 226.0         | 22.9       |
| 17034.600000    | 55.51            | ---              | 74.00          | 18.49       | 50.0       | 1000.000    | 100.0   | H    | 26.0          | 23.9       |
| 17034.600000    | ---              | 44.07            | 54.00          | 9.93        | 50.0       | 1000.000    | 100.0   | H    | 26.0          | 23.9       |

Note:

1. Emission level(peak or average)=Raw value by receiver + Corr(Antenna factor+ cable loss - preamplifier gain)
2. The raw value is used to calculate by software which is not shown in the sheet.
3. Margin=limit value – emission level.

## 8.2 AC Conducted Emission

### Method of Measurement

For equipment that is designed to be connected to the public utility (AC) power line, the radio frequency voltage that is conducted back onto the AC power line on any frequency or frequencies with the band 150 kHz to 30MHz shall not exceed the limits. Both lines of the power mains connected to the EUT were checked for maximum conducted interference. Tested in accordance with the procedures of ANSI C63.4-2014, section 7.3

### Limit of Conducted Emission

| Frequency Range (MHz) | Conducted Limit (dBuV) |           |
|-----------------------|------------------------|-----------|
|                       | Quasi-peak             | Average   |
| 0.15-0.5              | 66 to 56*              | 56 to 46* |
| 0.5-5                 | 56                     | 46        |
| 5-30                  | 60                     | 50        |

\*Decreases with the logarithm of the frequency

### Test Condition in Charging Mode

| Voltage (V) | Frequency (Hz) | RBW   | Sweep Time (s) |
|-------------|----------------|-------|----------------|
| 120         | 60             | 9 kHz | Auto           |

### Uncertainty Measurement

The measurement uncertainty is 3.68dB (k=2).

### Test Results



Mode 1: Charge mode+CA04+BA04<Figure1>

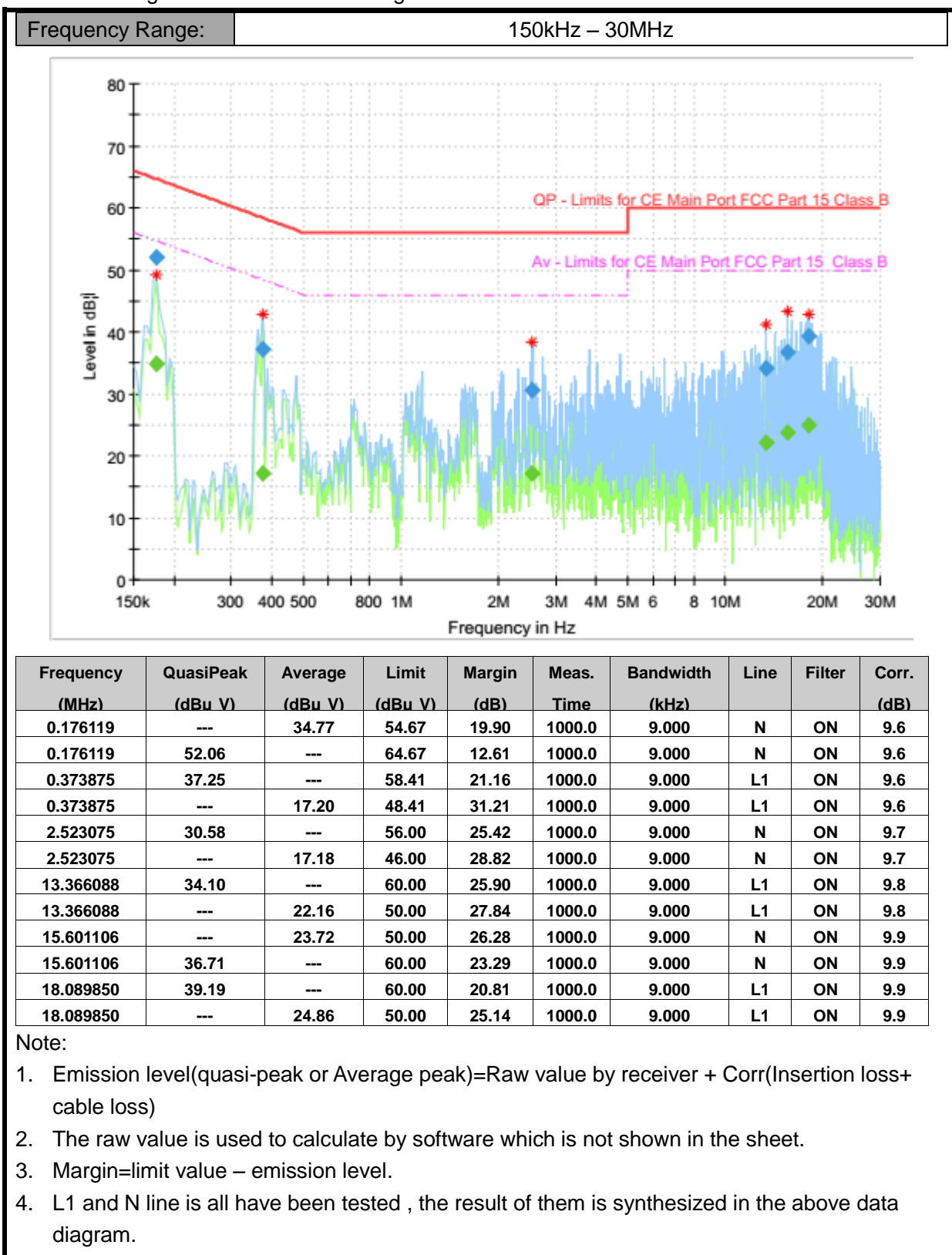

\*\*\*\*\* END OF REPORT\*\*\*\*\*