

NOT TO BE USED, COPIED, REPRODUCED IN WHOLE OR IN PART, NOR ITS CONTENTS REVEALED IN ANY MANNER TO OTHERS WITHOUT THE EXPRESS WRITTEN PERMISSION OF QUALCOMM.

This is preliminary version, for reference only

QUALCOMM Incorporated
12075 Morehouse Drive
San Diego, CA 92121-1714
U.S.A.

Title	
Sheet	Rev
Size	Date
Sheet	of

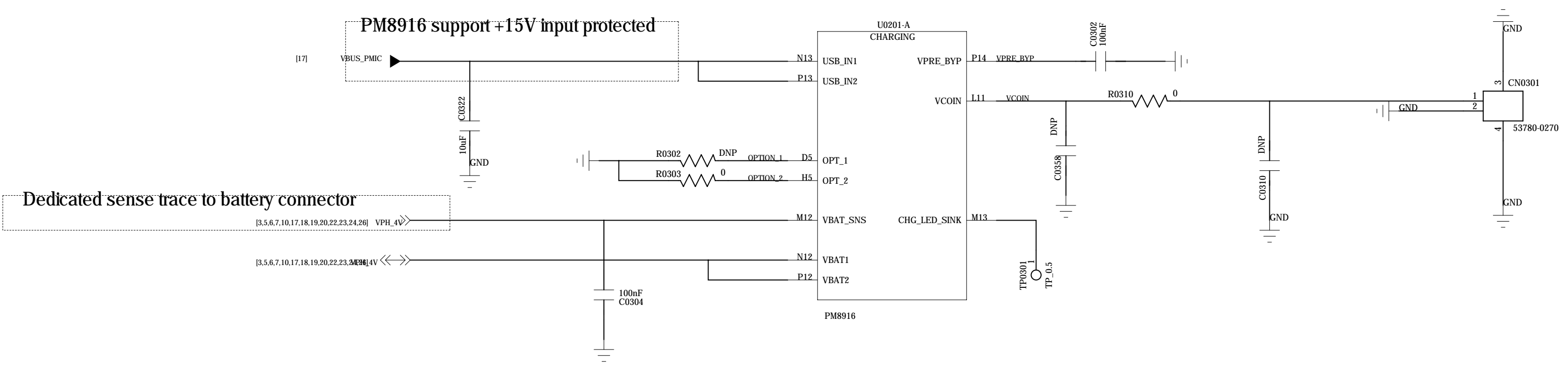

NOT TO BE USED, COPIED, REPRODUCED IN WHOLE OR IN PART, NOR ITS CONTENTS REVEALED IN ANY MANNER TO OTHERS WITHOUT THE EXPRESS WRITTEN PERMISSION OF QUALCOMM.

Title		
Sheet	Rev	
Size	Name	of
Date:	Sheet	of

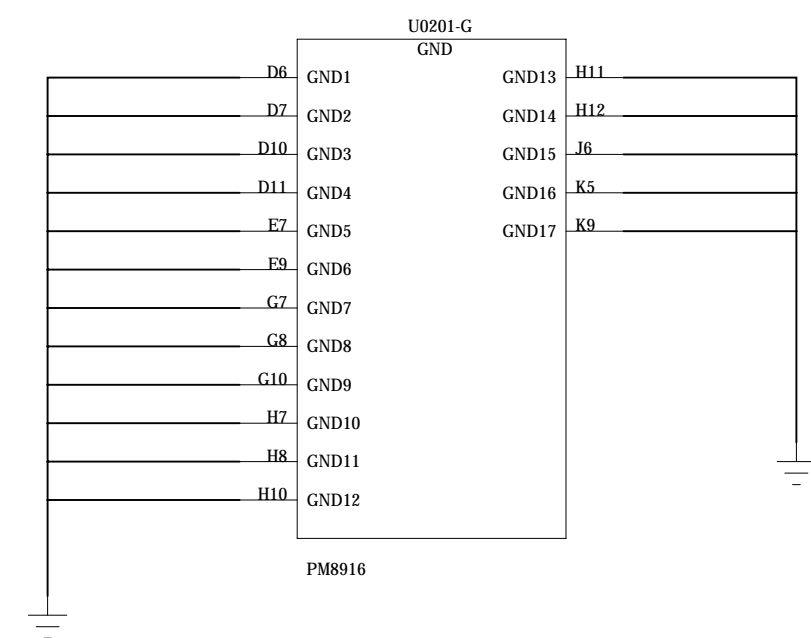
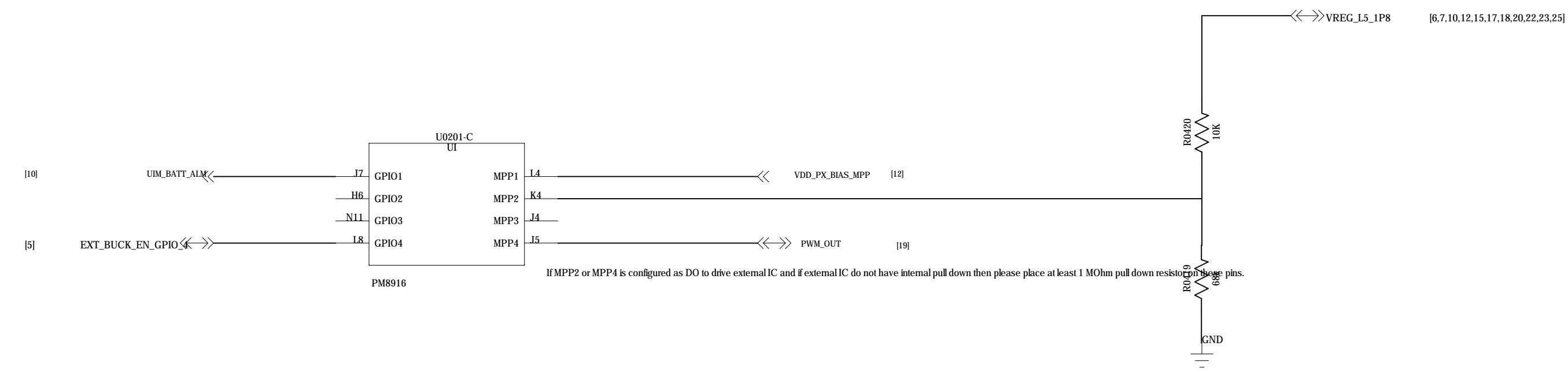

NOT TO BE USED, COPIED, REPRODUCED IN WHOLE OR IN PART, NOR ITS CONTENTS REVEALED IN ANY MANNER TO OTHERS WITHOUT THE EXPRESS WRITTEN PERMISSION OF QUALCOMM.

QUALCOMM Incorporated
 1775 Morehouse Drive
 San Diego, CA 92121-1714
 U.S.A.

Title		
Sheet	of	
Size	Name	Rev
Date	Sheet	of

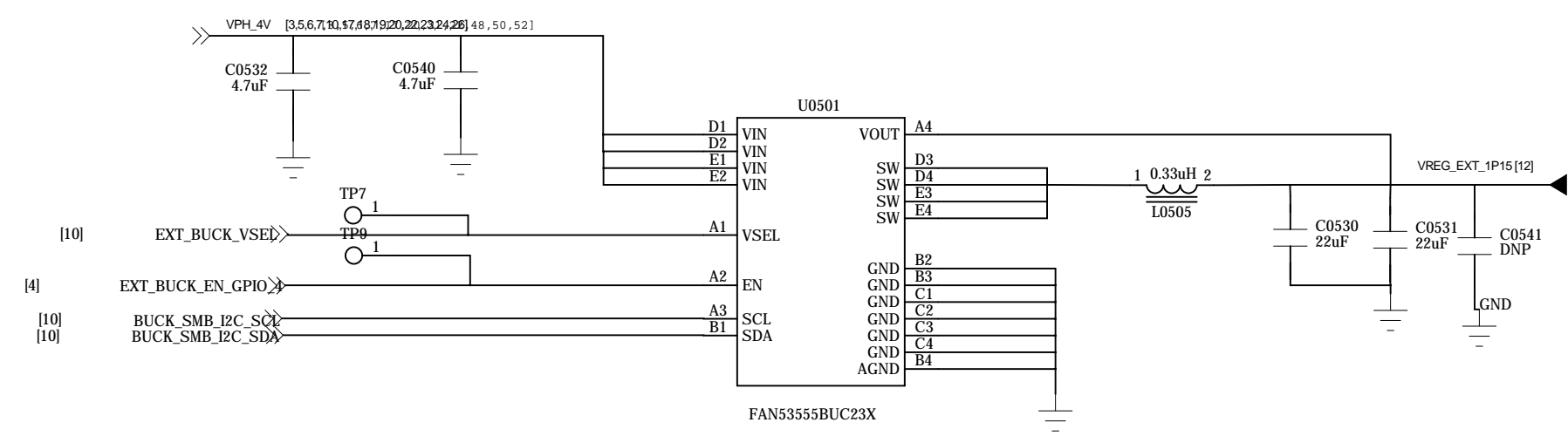
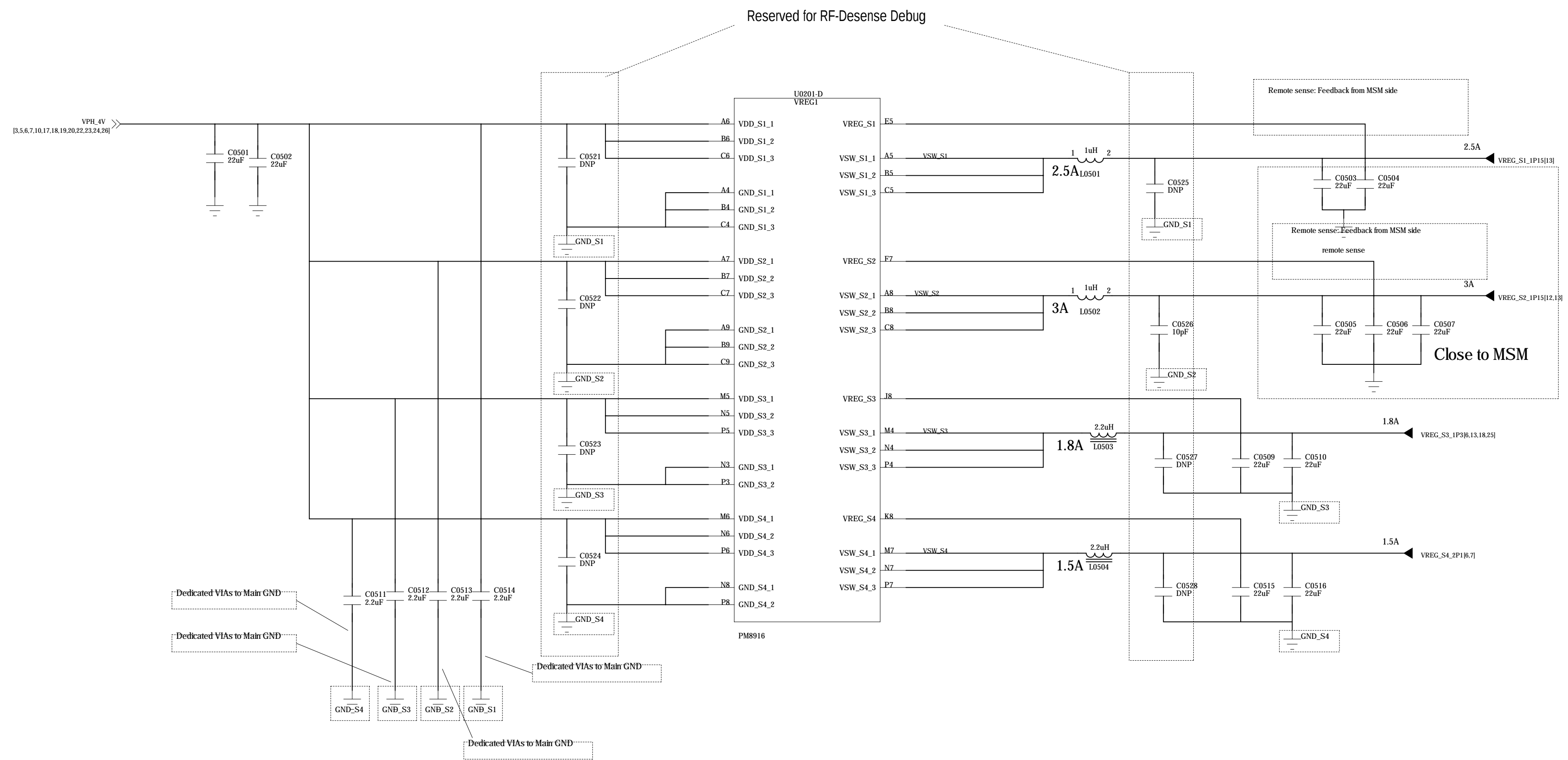

NOT TO BE USED, COPIED, REPRODUCED IN WHOLE OR IN PART, NOR ITS CONTENTS REVEALED IN ANY MANNER TO OTHERS WITHOUT THE EXPRESS WRITTEN PERMISSION OF QUALCOMM.

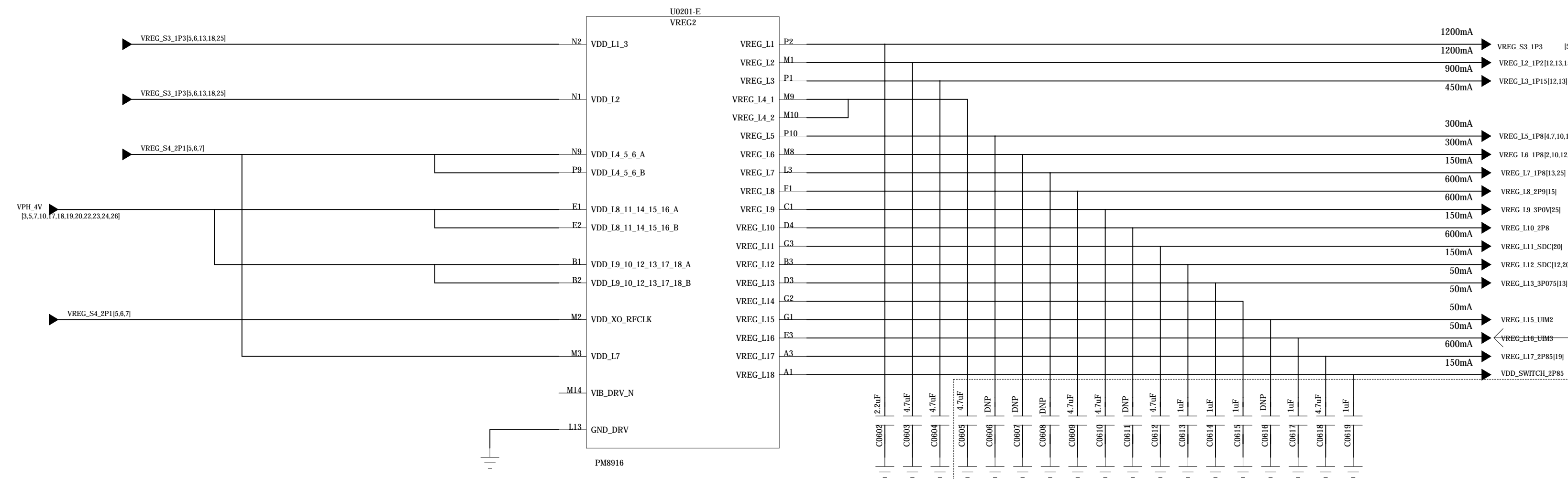

Software Caution:
L16 Need to Config to 1.8V and turn on later than L17

PSEUDO CAPLESS LDOs
L4, L5, L6, L7, L8, L9, L10, L11, L12, L13, L14, L15, L16, L17, L18

Local output capacitor can NC/Remove depends on remote load capacitors and PCB layout
 LDOs L8, L9, L11, L17 each shall have total effective output capacitance of 4.7uF.
 Please refer to PM8916 training slides(80-NK808-21) for limits on LDO output trace resistance and inductance
 Rest of the LDOs shall each have total effective output capacitance of 1.0uF
 Please ensure when you DNI the output capacitor of Pseudo capless LDOs
 the effective total capacitance at load side shall match above requirement

NOT TO BE USED, COPIED, REPRODUCED IN WHOLE OR IN PART, NOR ITS CONTENTS REVEALED IN ANY MANNER TO OTHERS WITHOUT THE EXPRESS WRITTEN PERMISSION OF QUALCOMM.

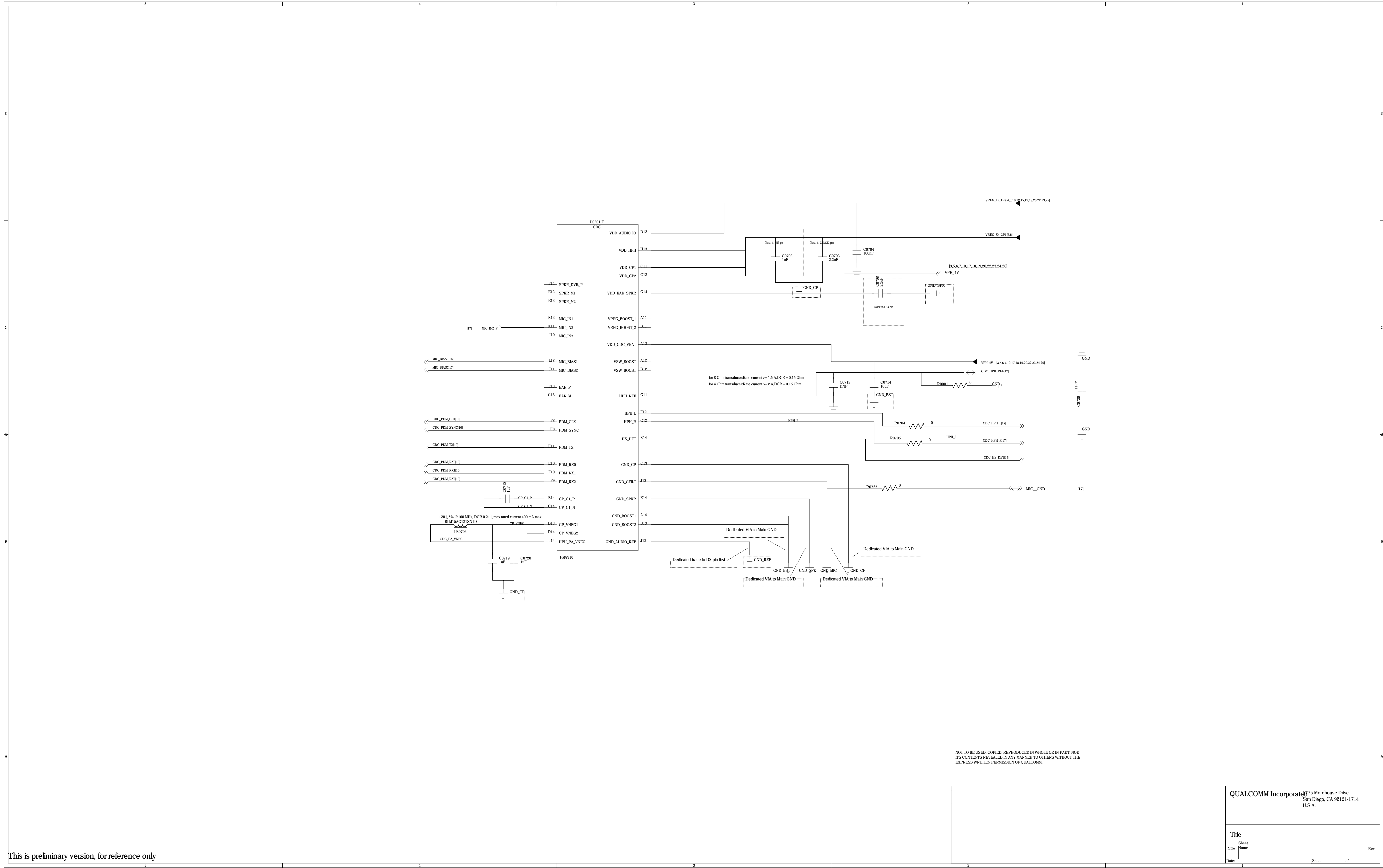

This is preliminary version, for reference only

NOT TO BE USED, COPIED, REPRODUCED IN WHOLE OR IN PART, NOR ITS CONTENTS REVEALED IN ANY MANNER TO OTHERS WITHOUT THE EXPRESS WRITTEN PERMISSION OF QUALCOMM.

QUALCOMM Incorporated
 175 Morehouse Drive
 San Diego, CA 92121-1714
 U.S.A.

Title	
Sheet	Rev
Size	Name
Date	Sheet of

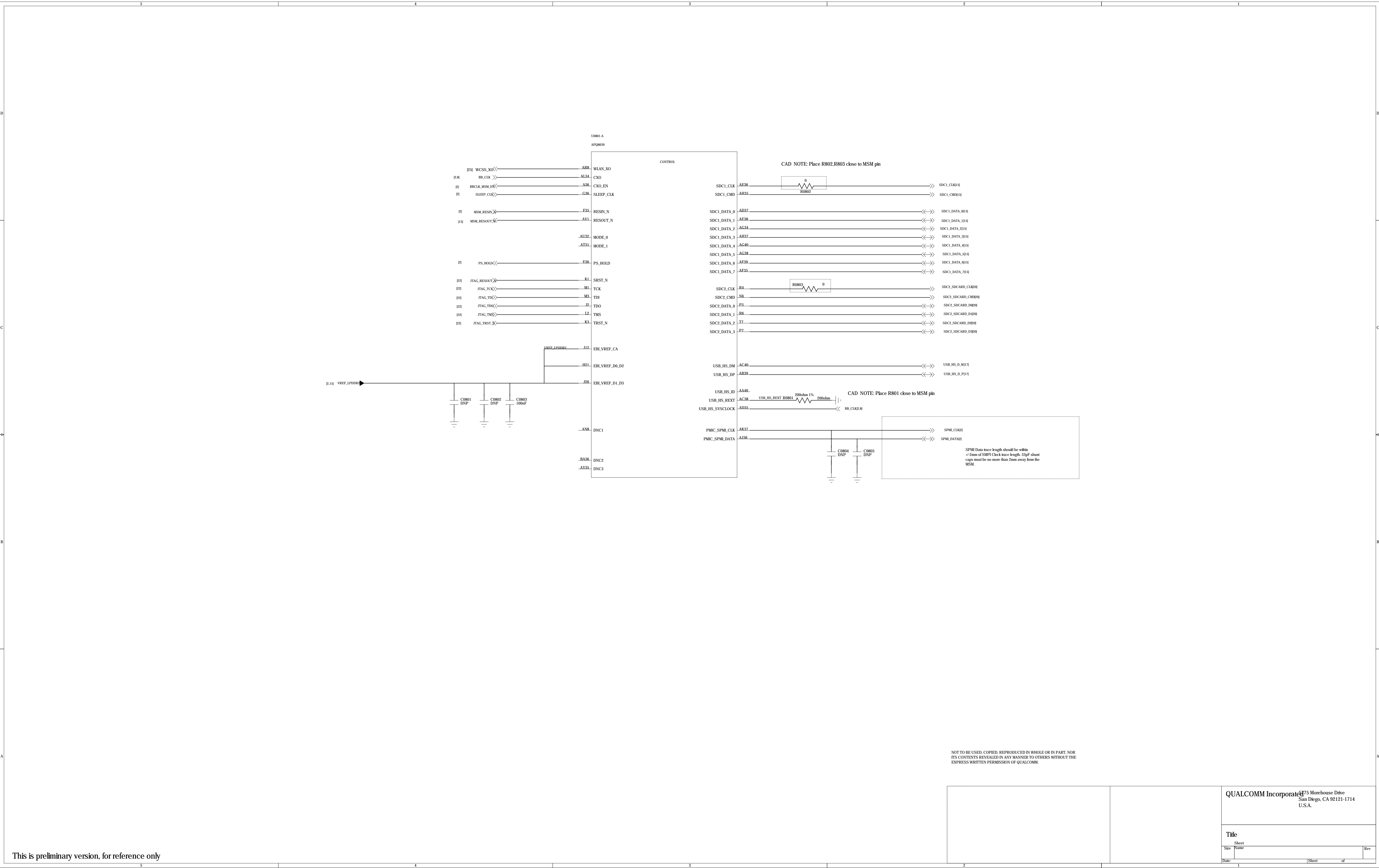

NOT TO BE USED, COPIED, REPRODUCED IN WHOLE OR IN PART, NOR ITS CONTENTS REVEALED IN ANY MANNER TO OTHERS WITHOUT THE EXPRESS WRITTEN PERMISSION OF QUALCOMM.

QUALCOMM Incorporated
12075 Morehouse Drive
San Diego, CA 92121-1714
U.S.A.

Title	
Sheet	Rev
Size	Date
1 of 1	

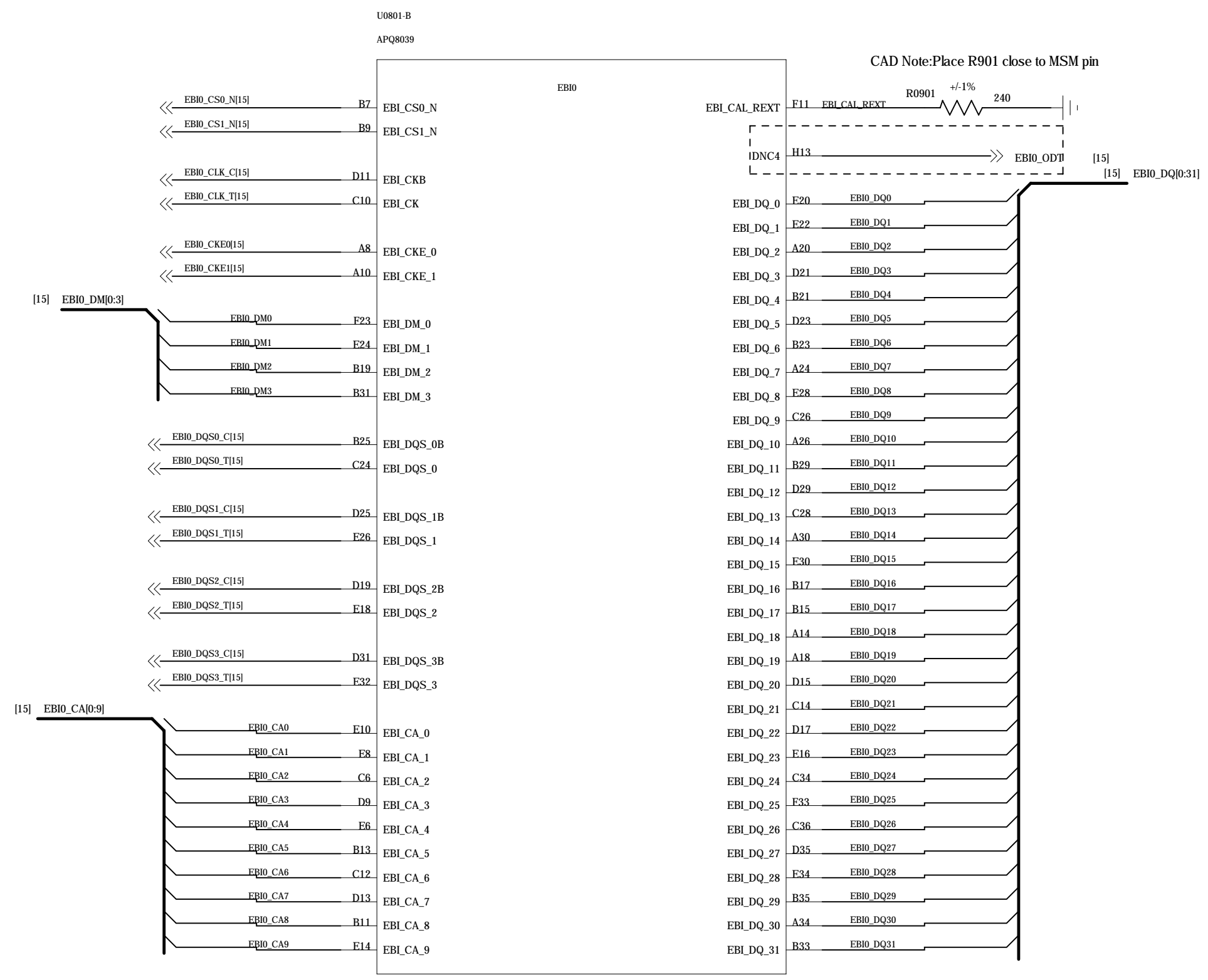

NOTE: Connect MSM Pad H13 to LPDDR3 PAD P10 if ODT is used

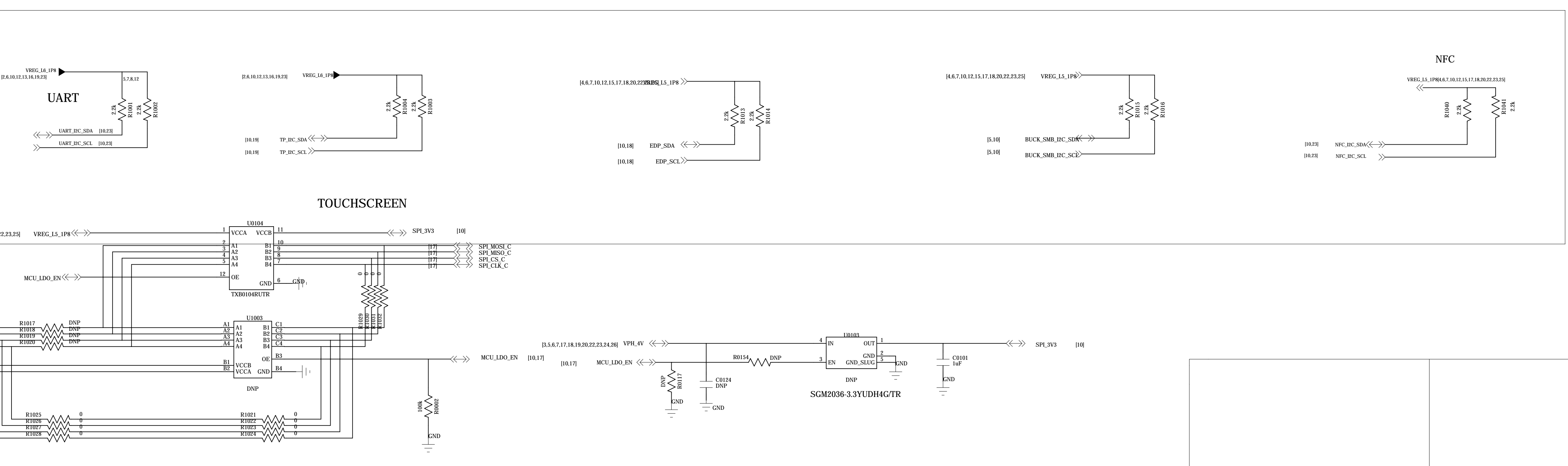
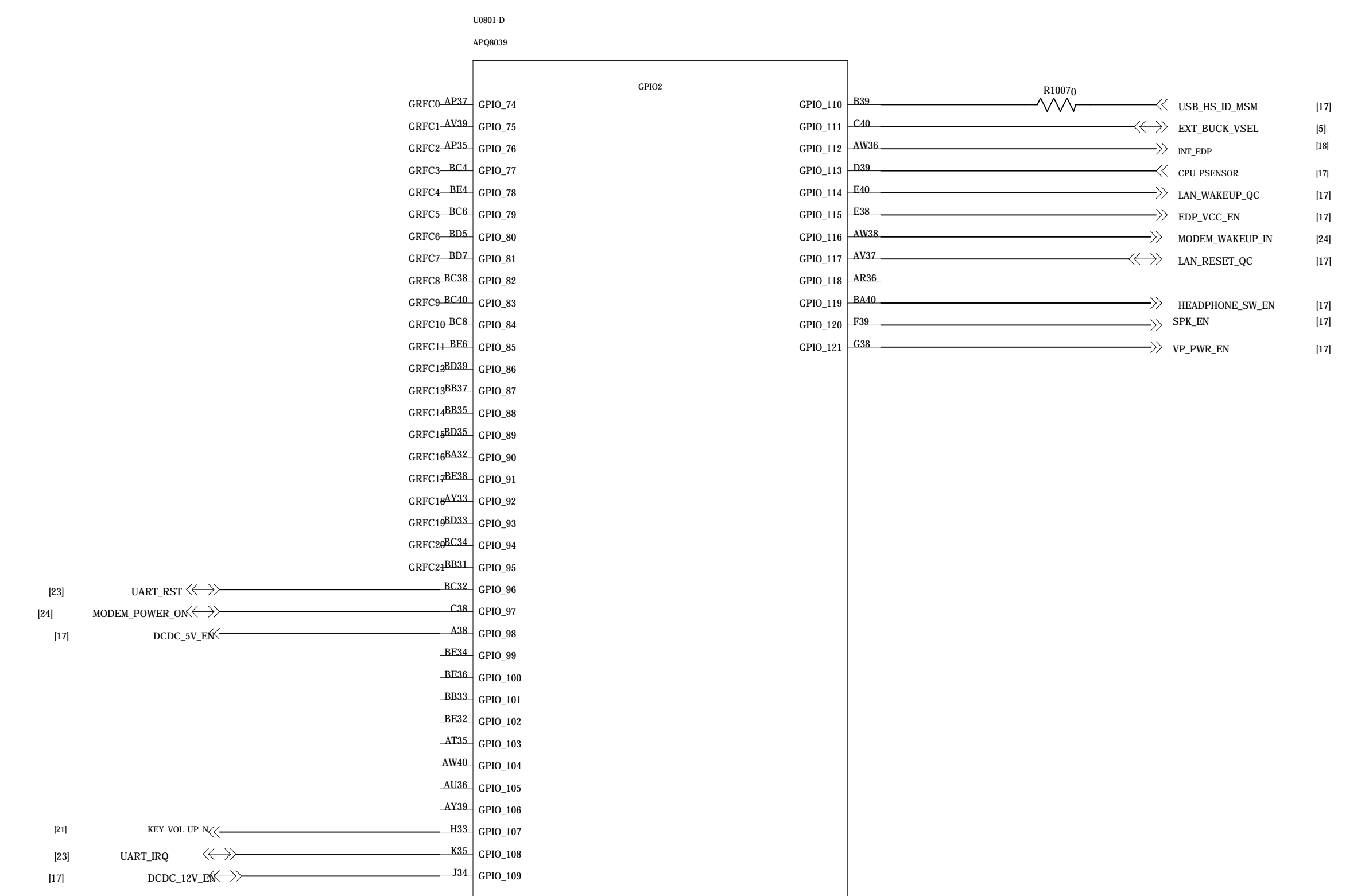
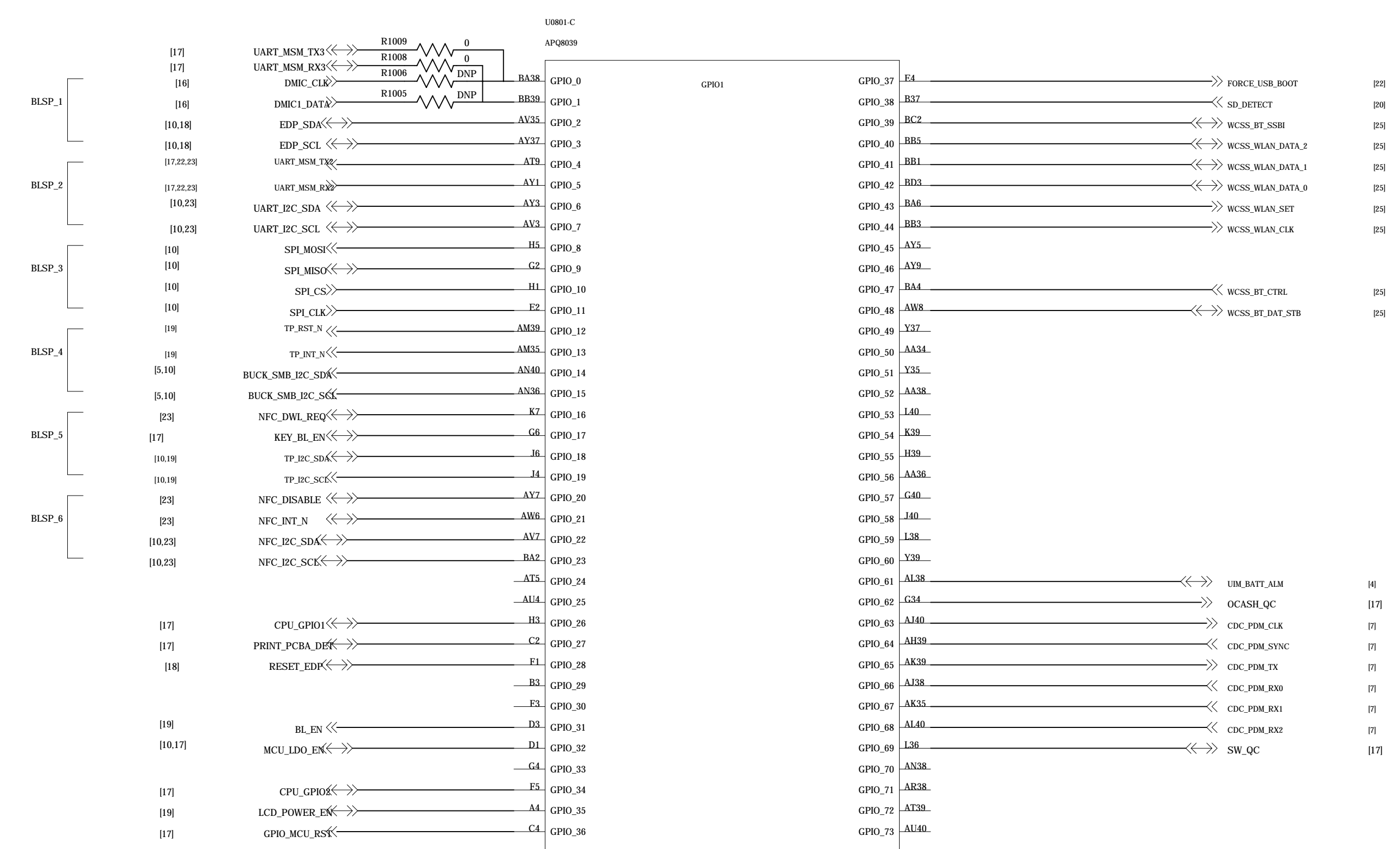

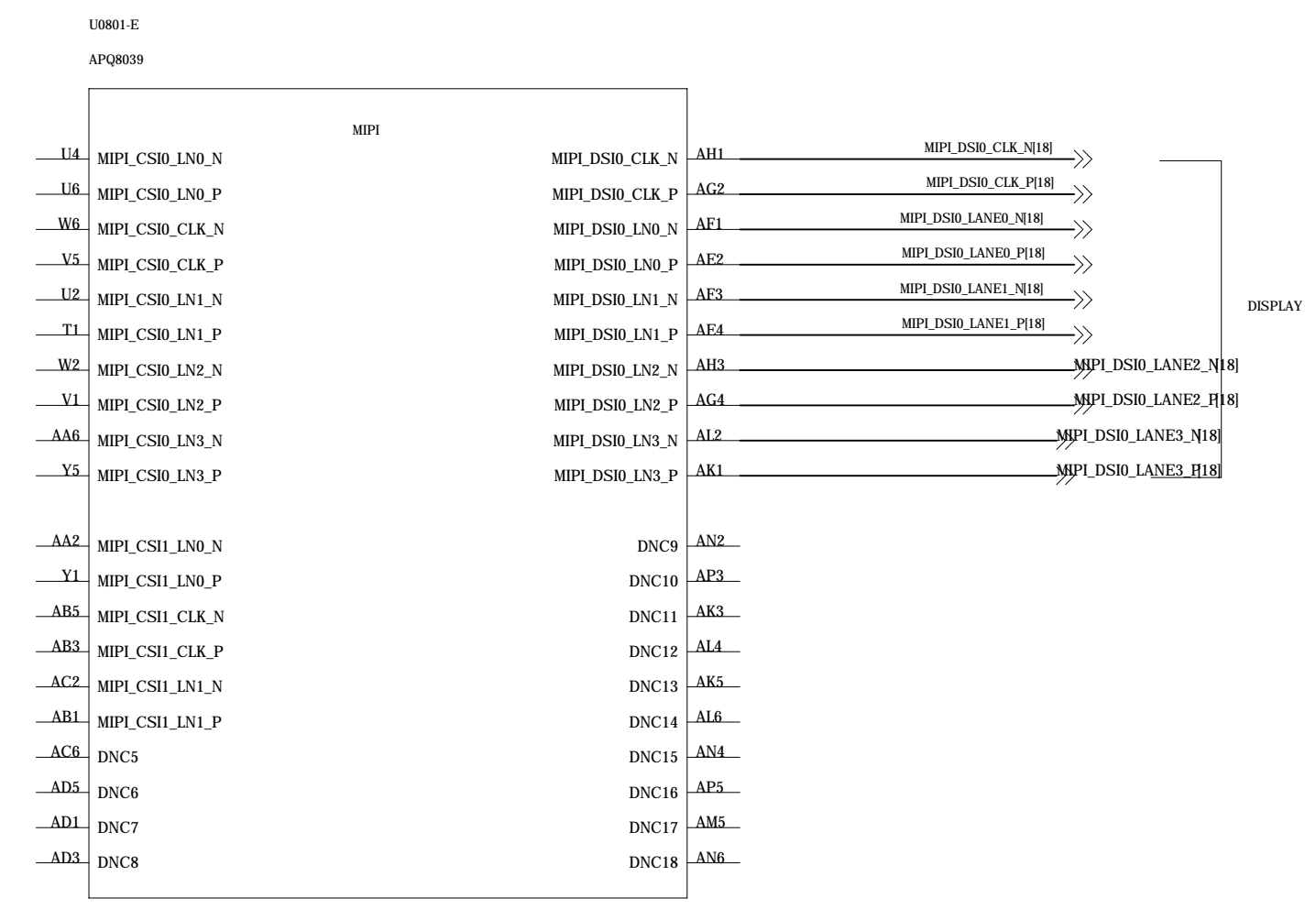

NOTE:
MSM8916 CONFIG:
REAR CAMERA: 13MP(4-LANE)
FRONET CAMERA: 5MP(2-LANE)

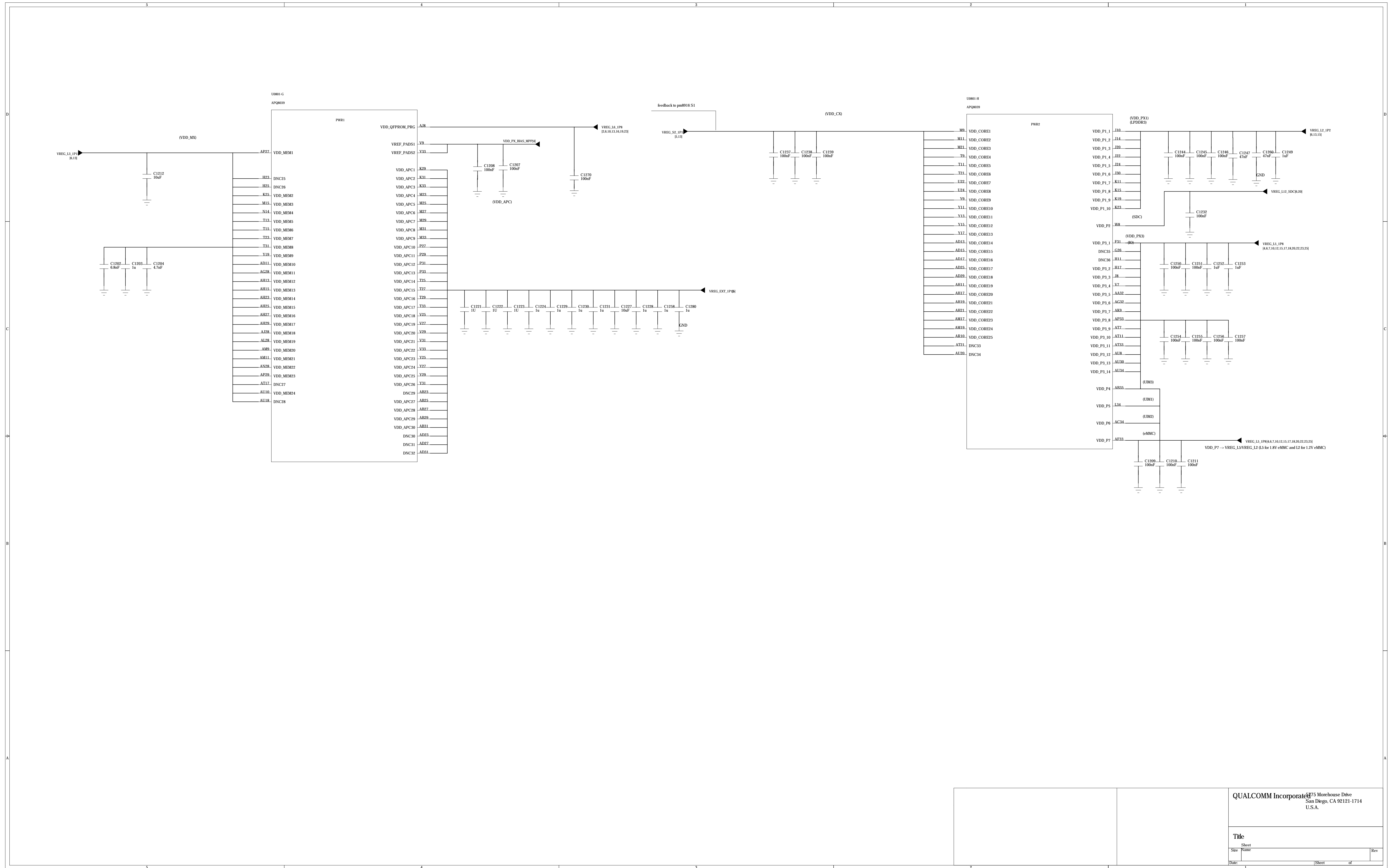

QUALCOMM Incorporated
 75 Morehouse Drive
 San Diego, CA 92121-1714
 U.S.A.

Title	
Sheet	Rev
Date	of

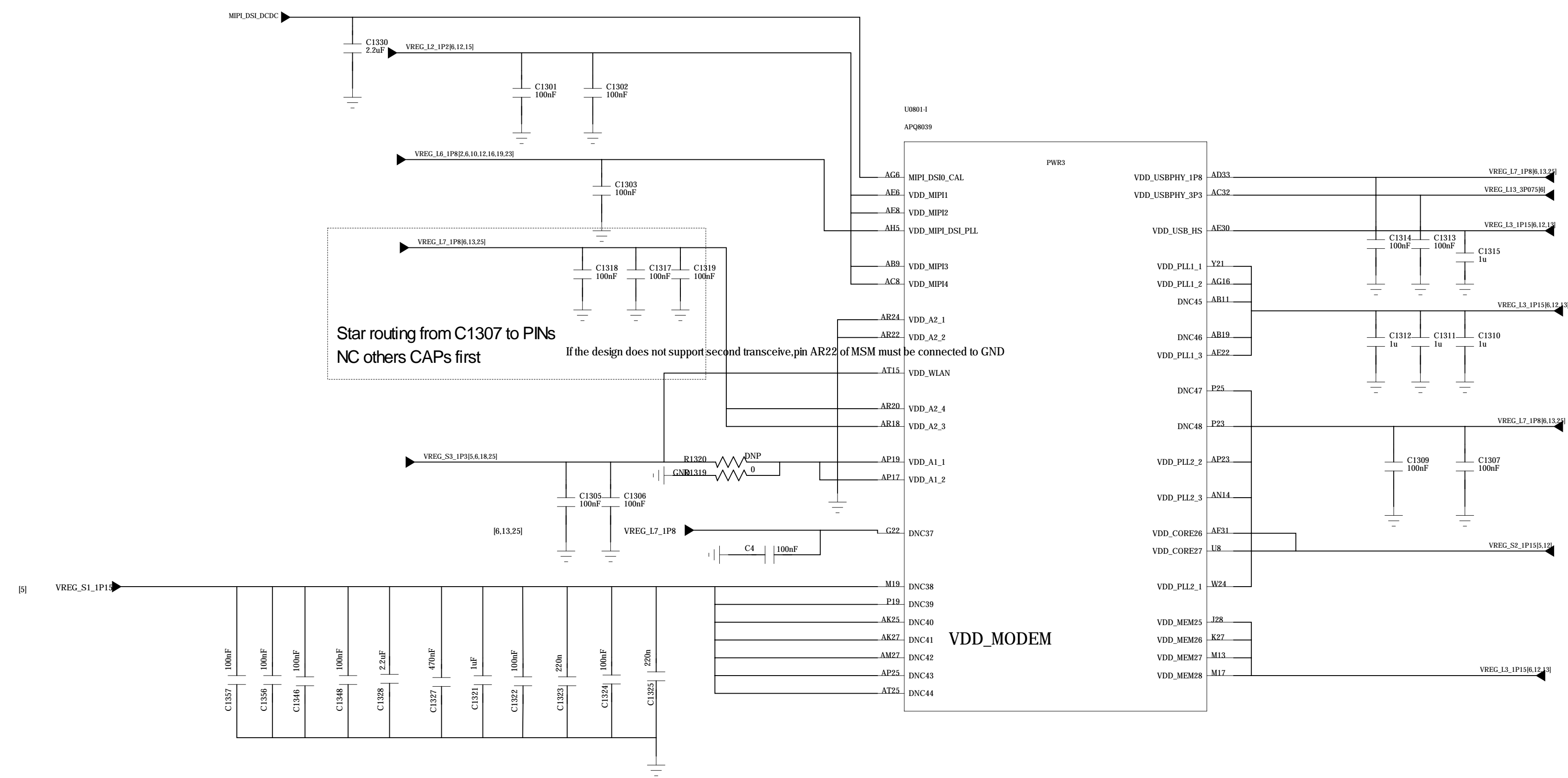

QUALCOMM Incorporated
12075 Morehouse Drive
San Diego, CA 92121-1714
U.S.A.

Title	
Sheet	
Size	Name
Date:	Sheet of Rev

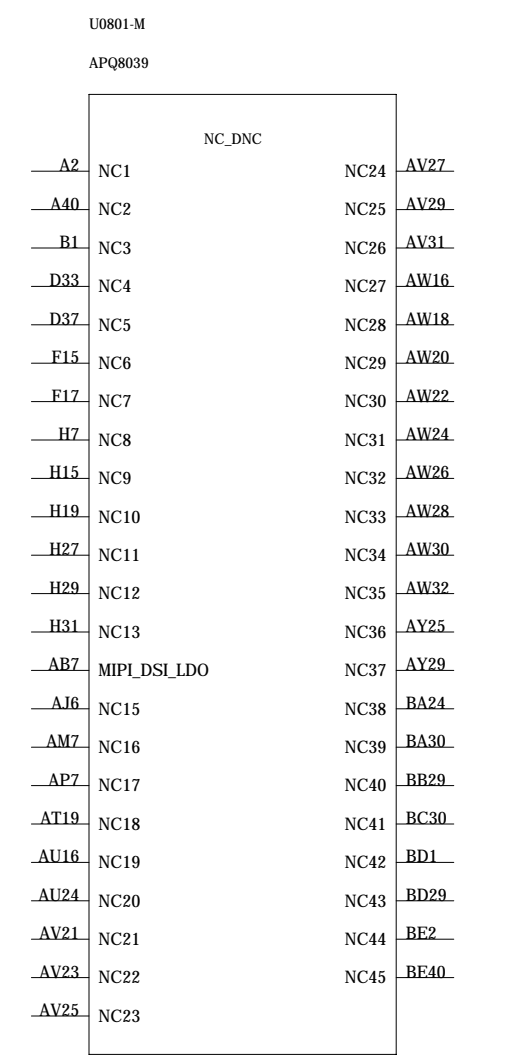
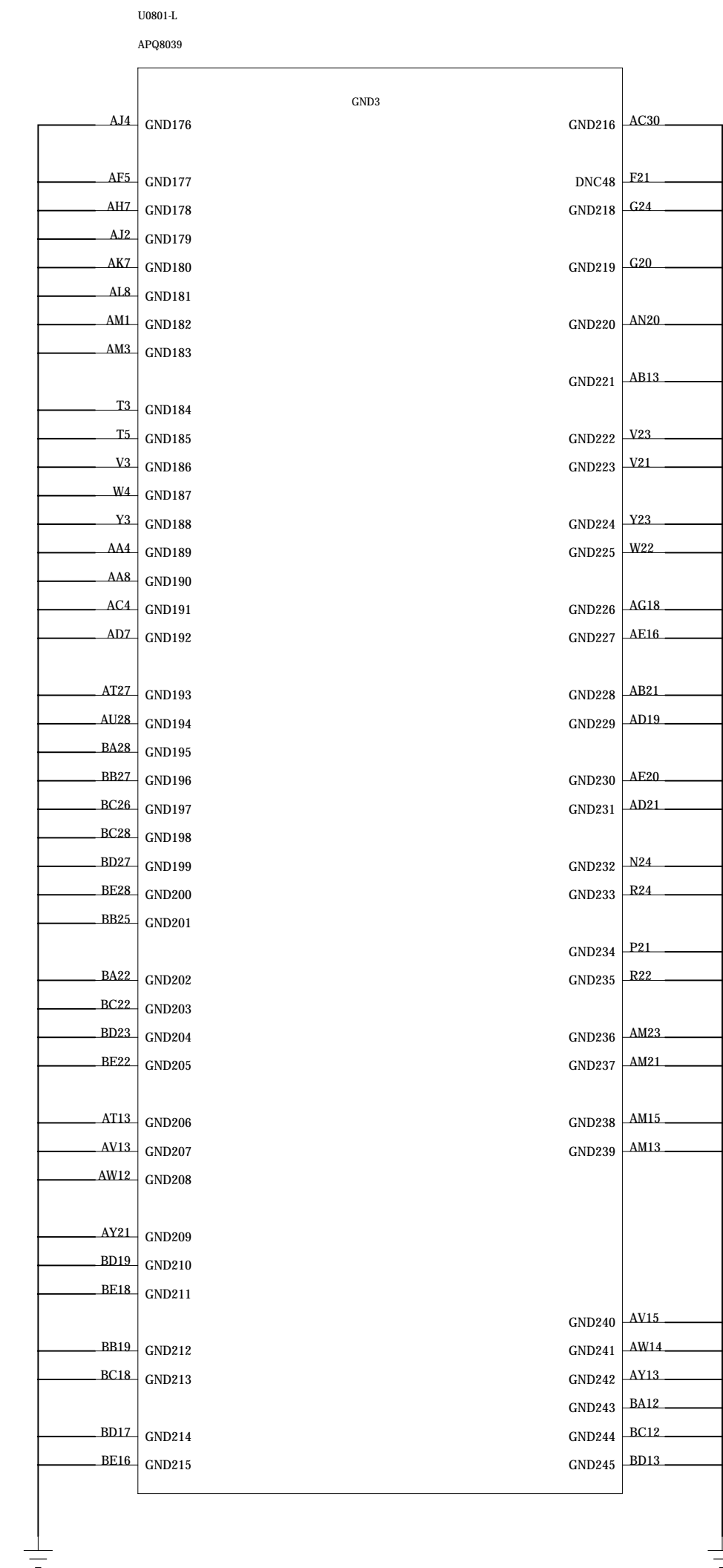
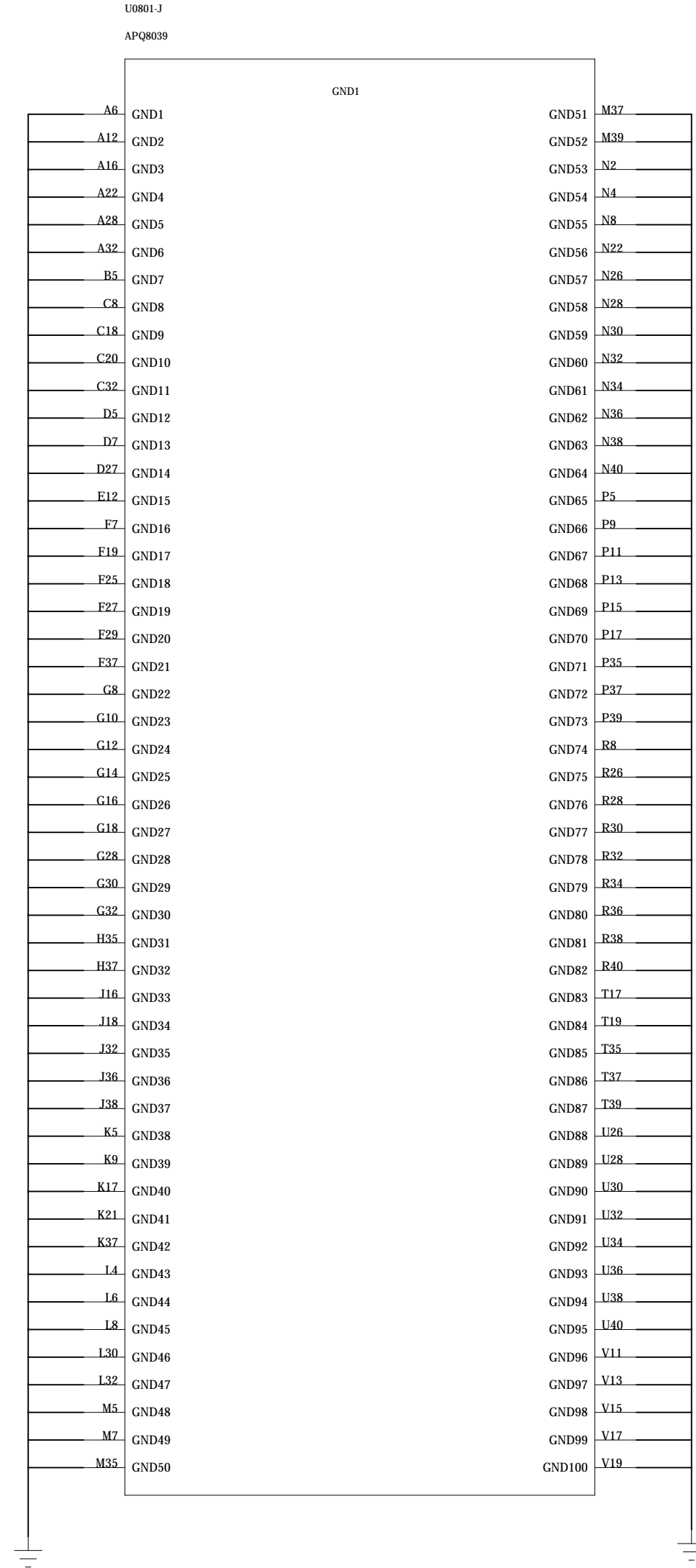
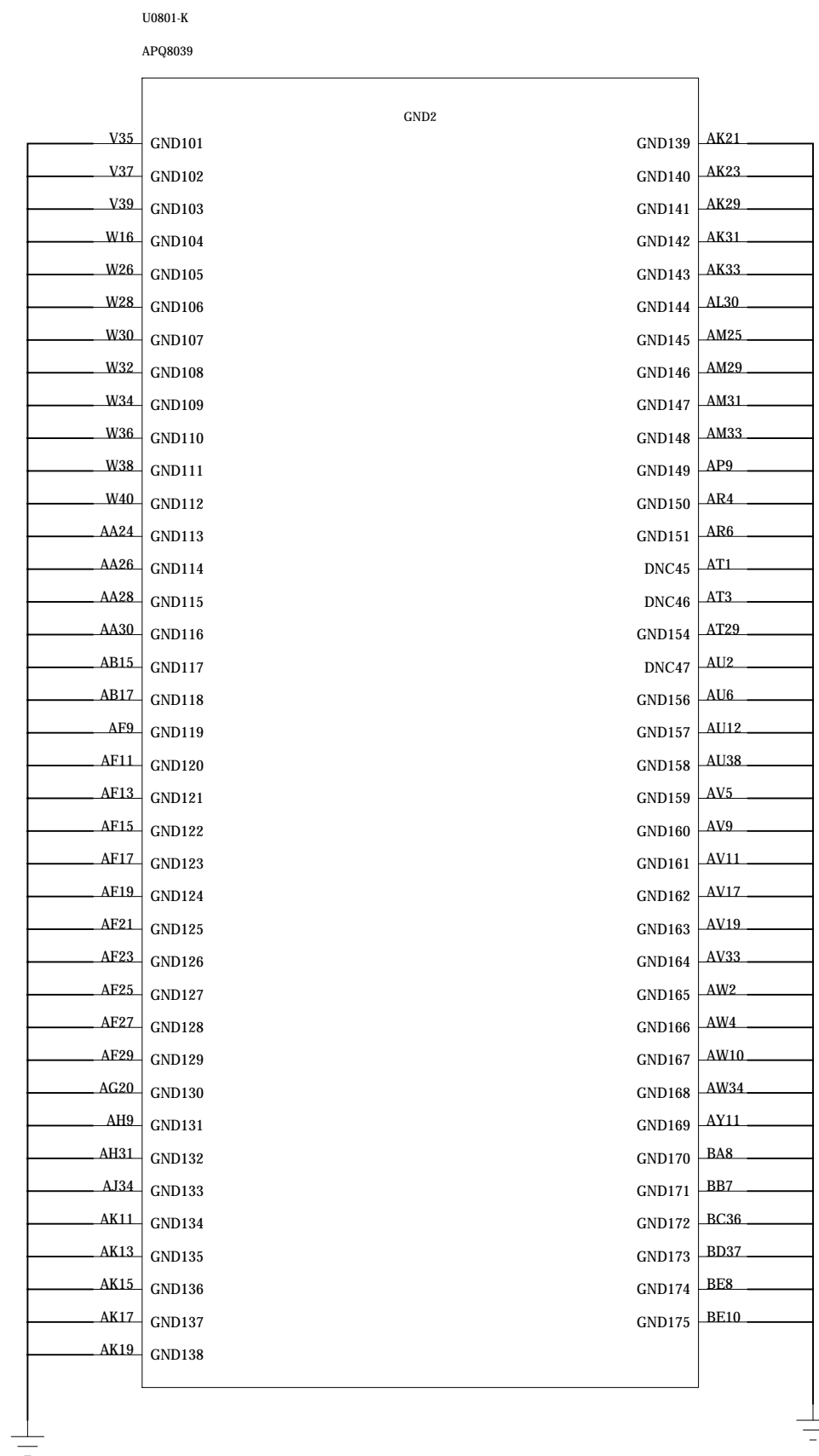

QUALCOMM Incorporated 75 Morehouse Drive
San Diego, CA 92121-1714
U.S.A.

Title	
Sheet	Rev
Size	Name
Date	Sheet of

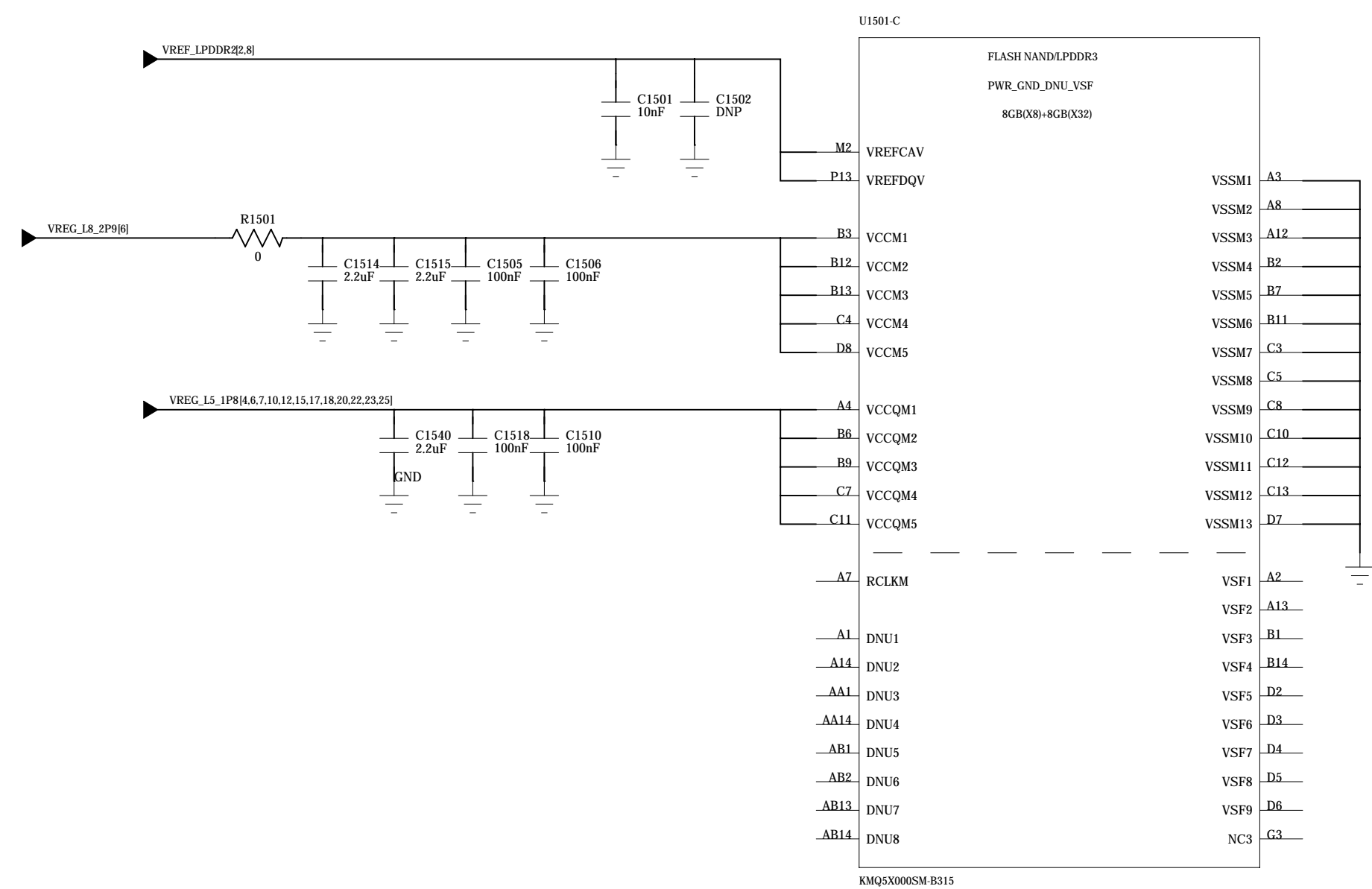

VDDCA decaps must be < 1.5mm from package edge

VDD1 decaps must be < 5mm from package edge

VDD2 decaps must be < 1.5mm from package edge

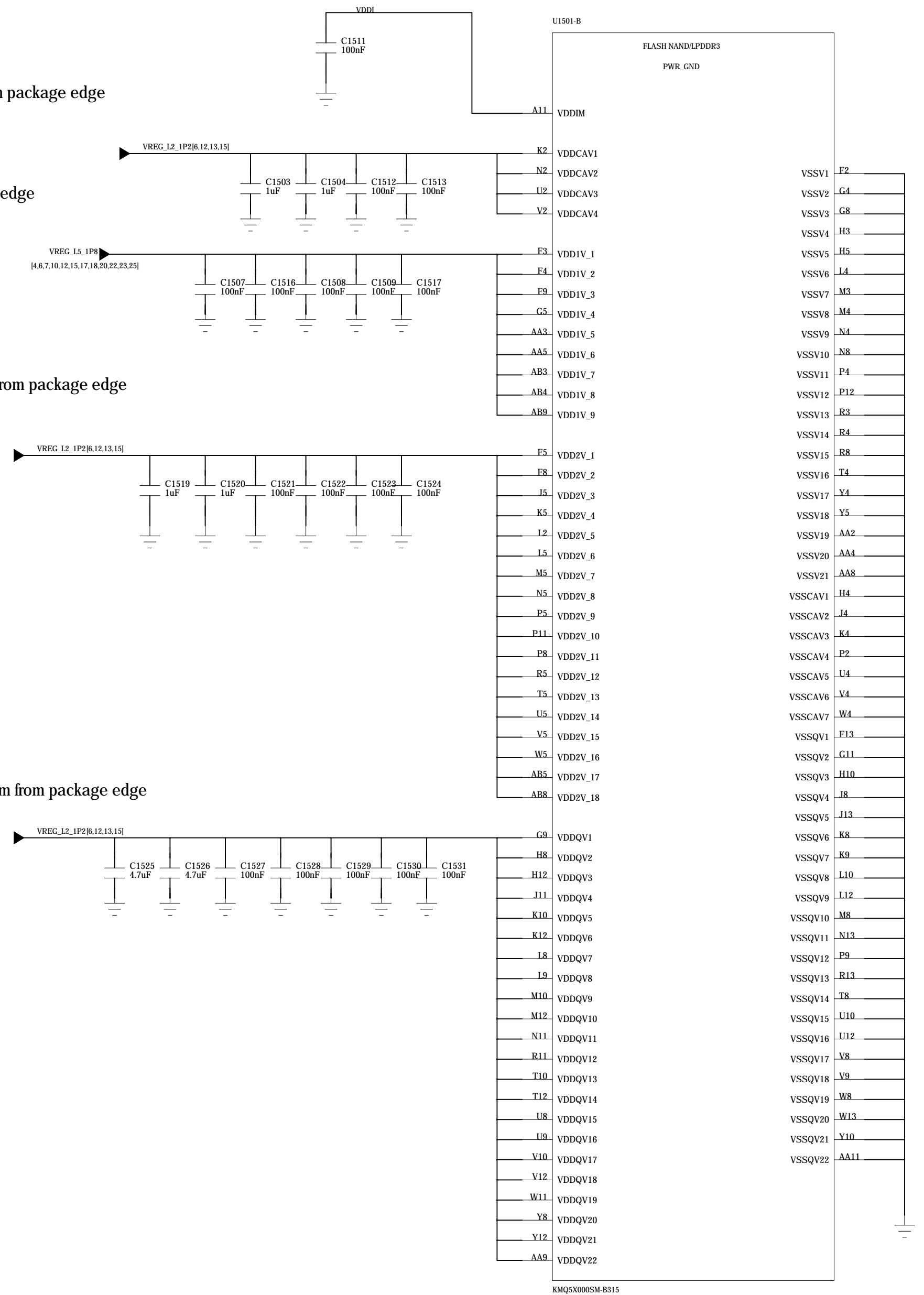

Use solid Plane for L2
VDD2 decaps must be < 1.5mm from package edge

Note: Pull-up resistors on SDC1_DATA are PCB and eMMC vender dependent

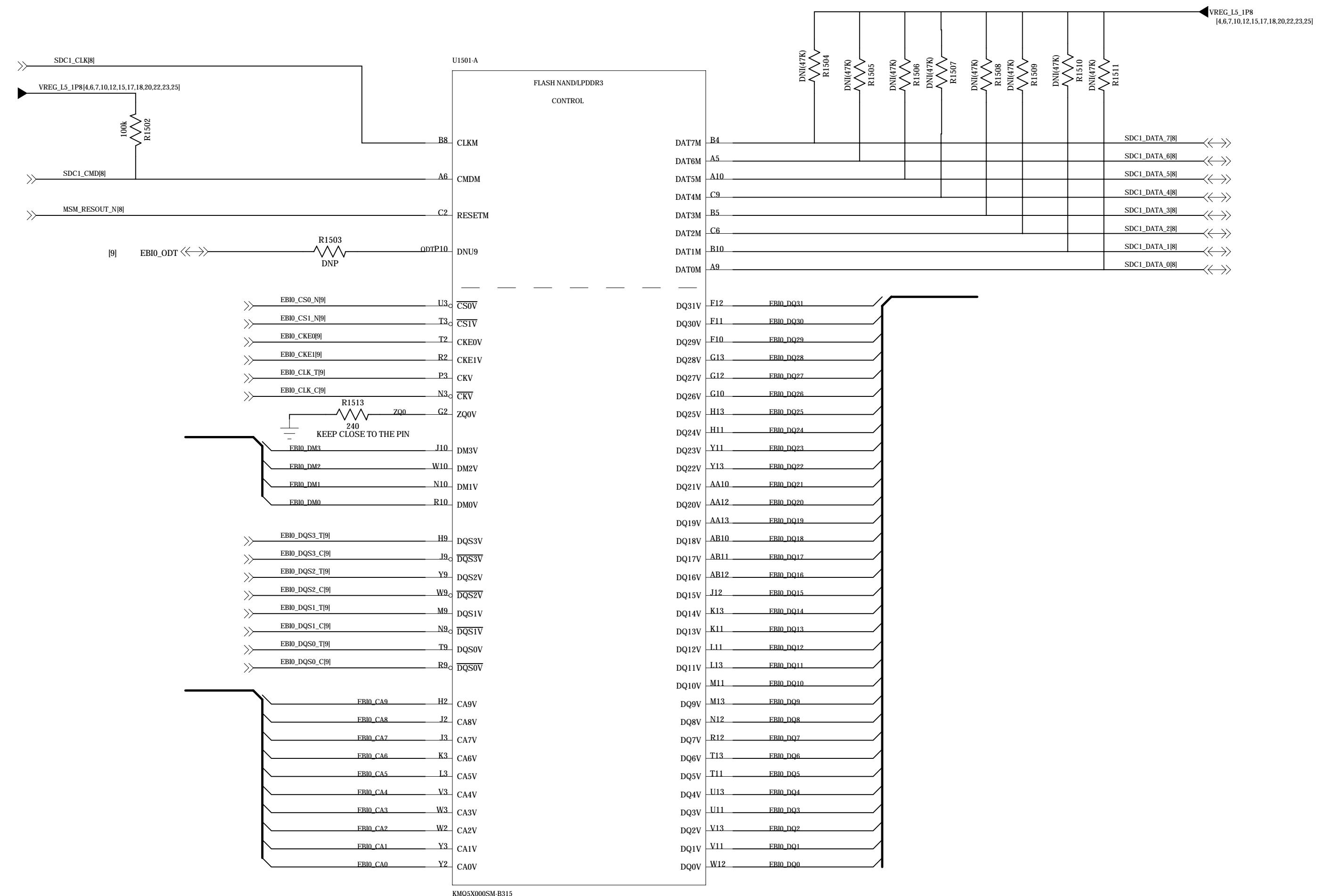

NOT TO BE USED, COPIED, REPRODUCED IN WHOLE OR IN PART, NOR ITS CONTENTS REVEALED IN ANY MANNER TO OTHERS WITHOUT THE EXPRESS WRITTEN PERMISSION OF QUALCOMM.

QUALCOMM Incorporated
5775 Morehouse Drive
San Diego, CA 92121-1714
U.S.A.

Title		Rev
Size	Sheet Name	Rev
Date	Sheet of	

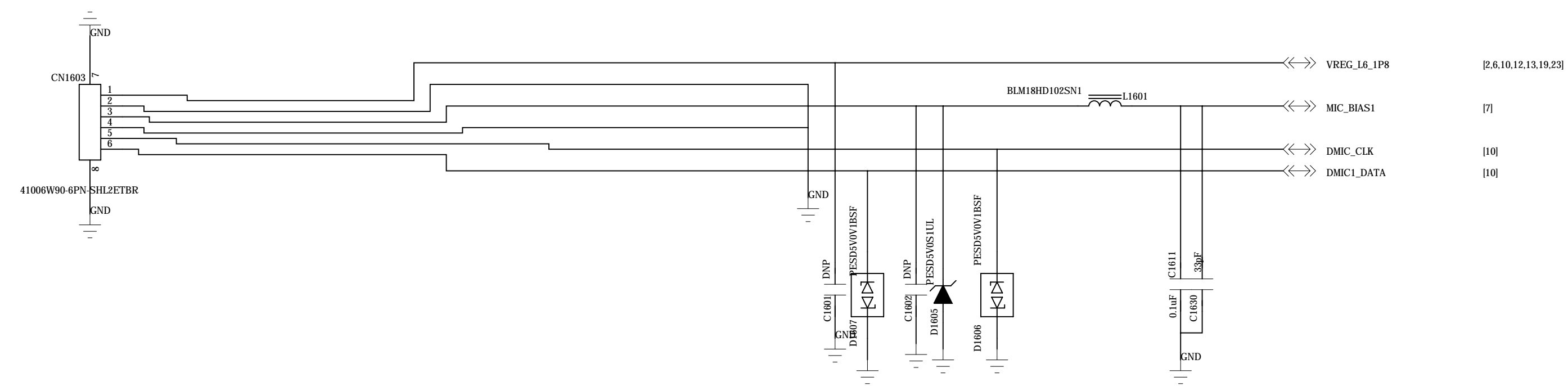

to MIC Board

QUALCOMM Incorporated
 75 Morehouse Drive
 San Diego, CA 92121-1714
 U.S.A.

Title	
Sheet	Rev
Size	Name
Date	Sheet of

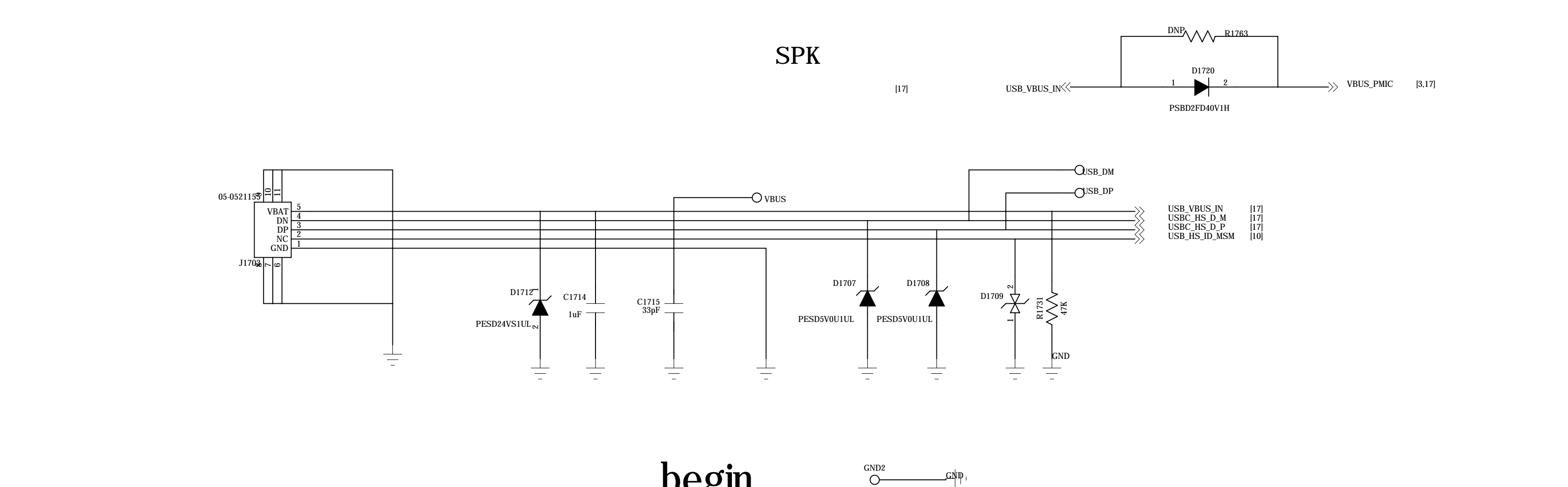
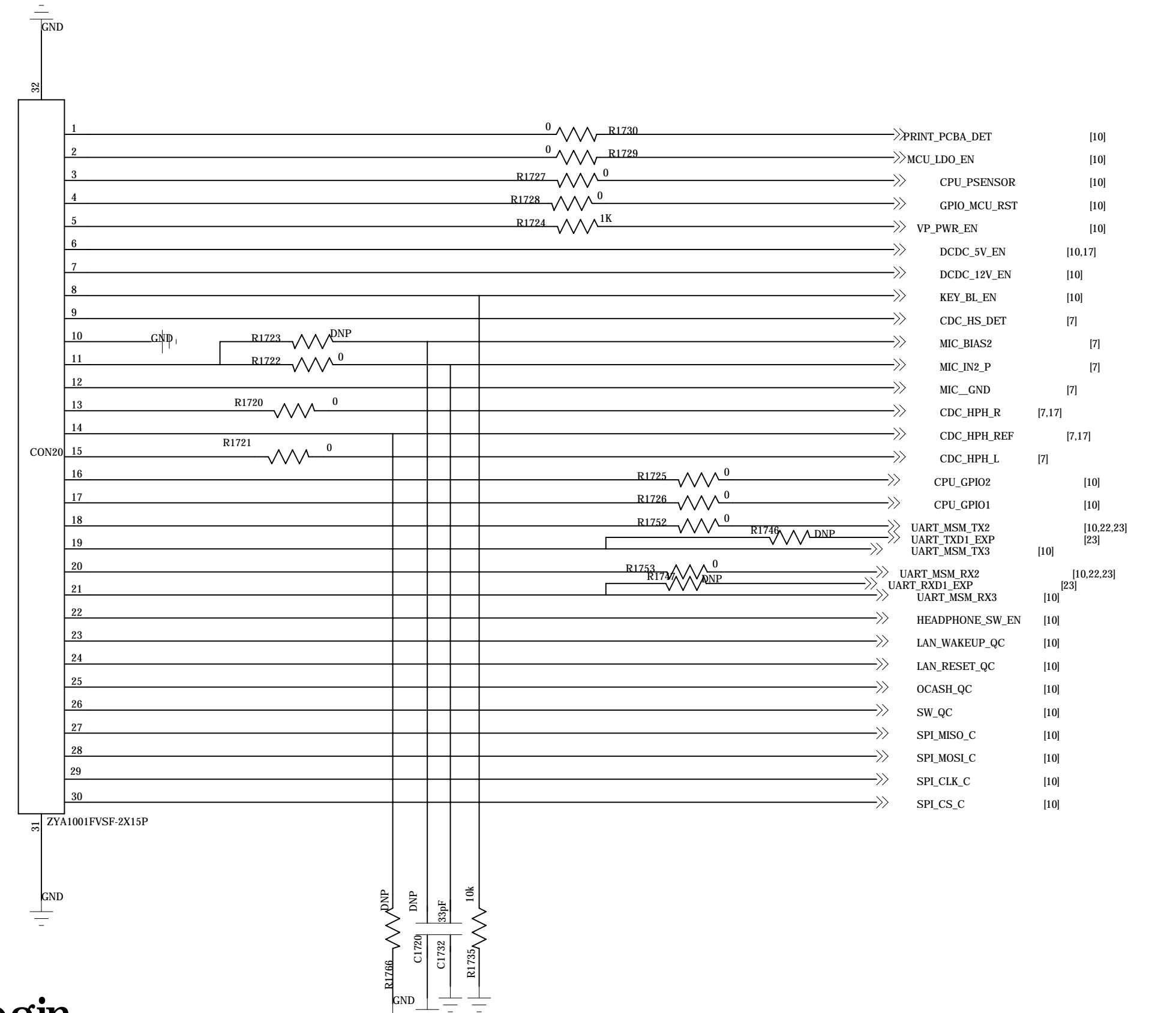
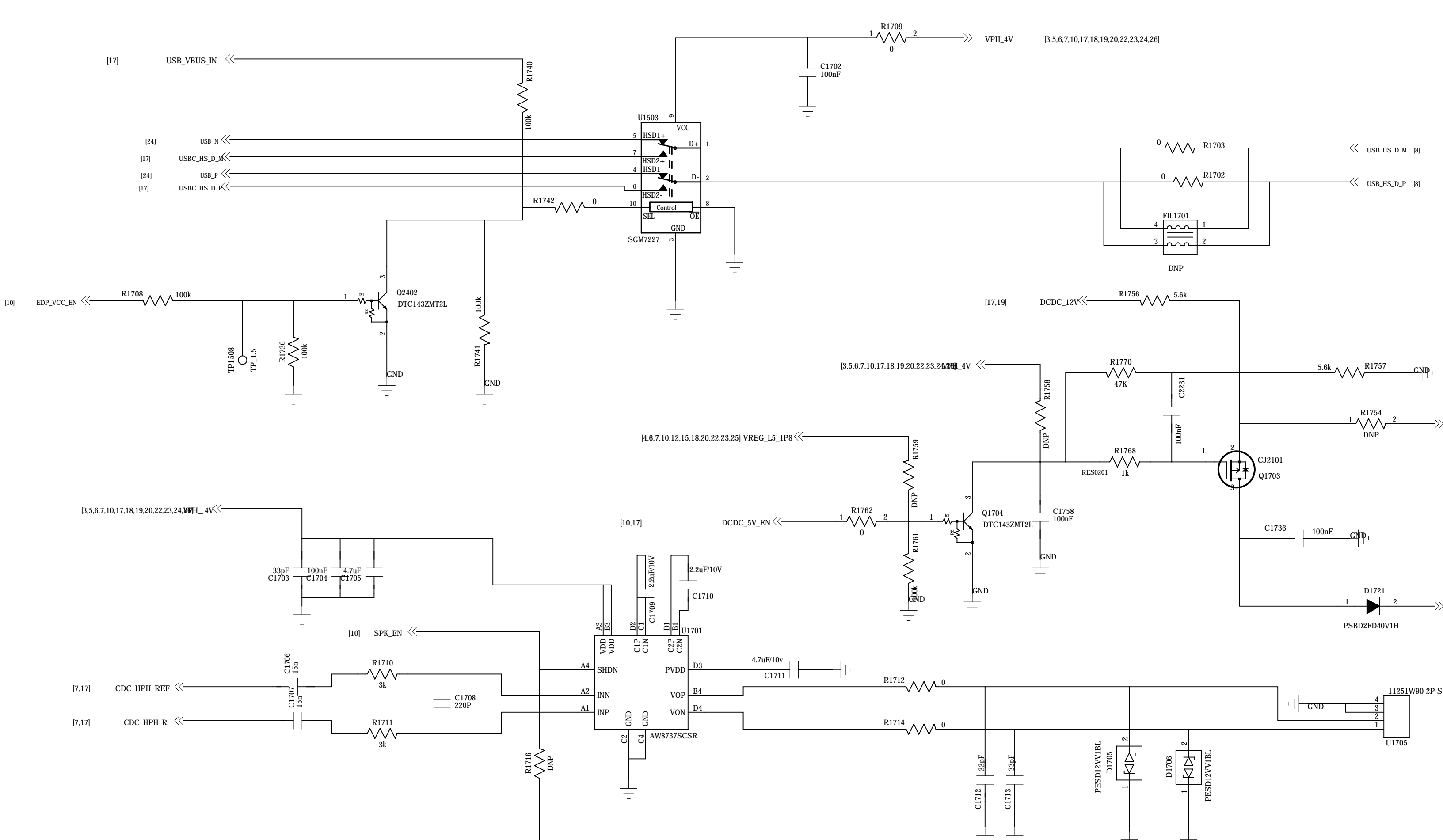
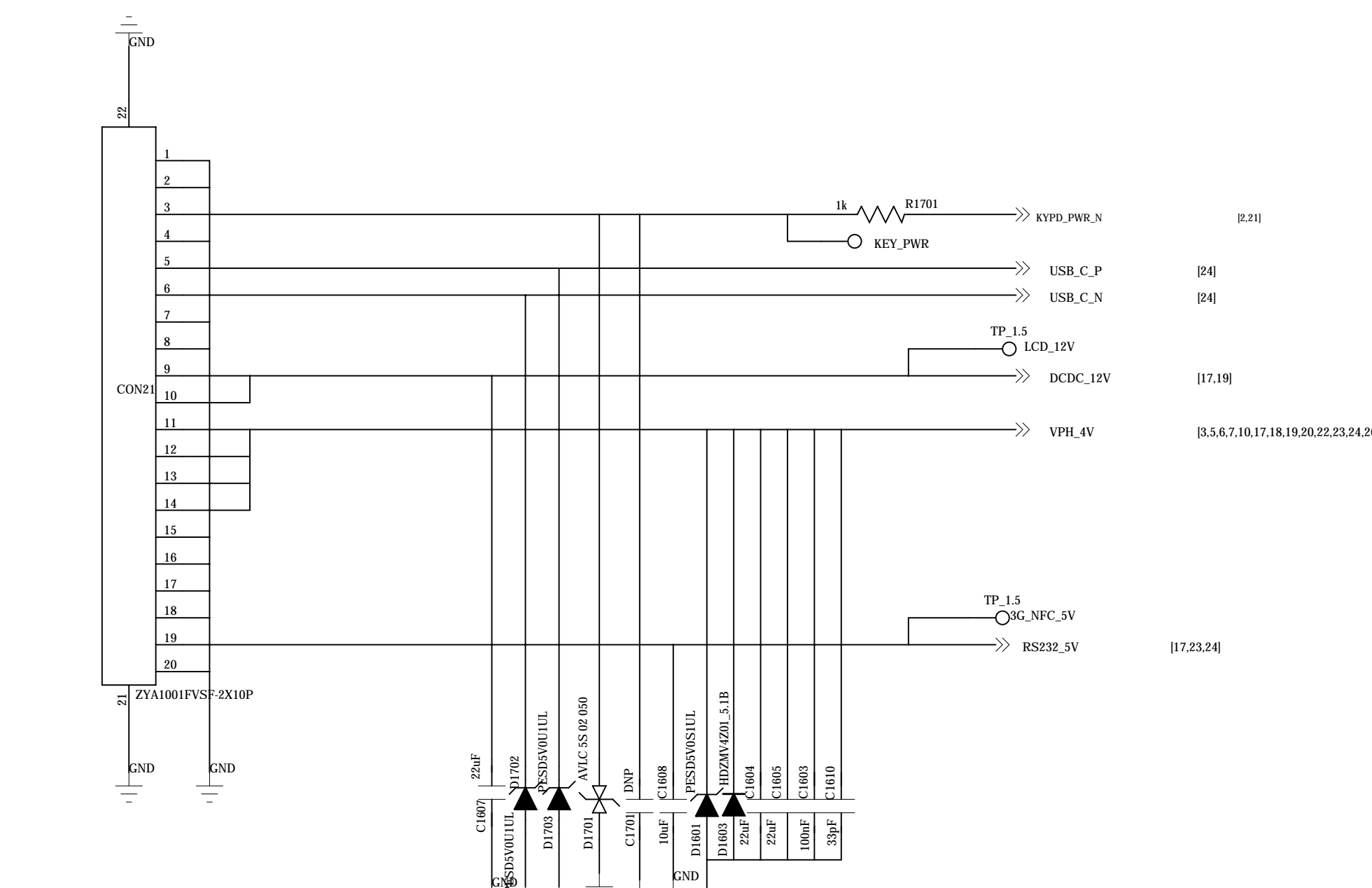

begin

begin

to Power Board

This is preliminary version, for reference only

QUALCOMM Incorporated		75 Morehouse Drive San Diego, CA 92121-1714 U.S.A.	
Title			
Sheet	Name		Rev
Date	Sheet		of

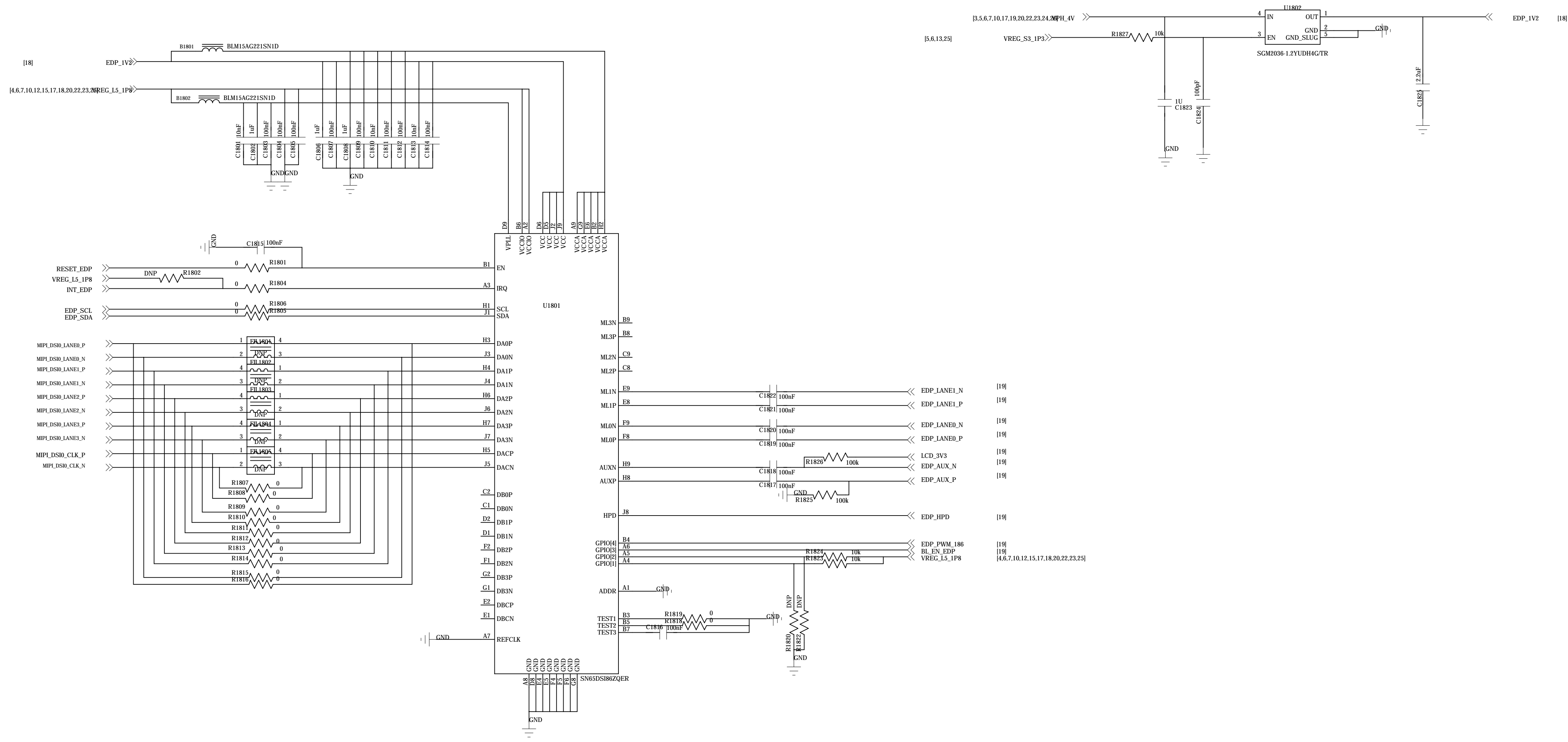

- [19] [4.6.7.10.12.15.17.18.20.22.23.25]
- [10] [10]
- [11] [11]
- [12] [12]
- [13] [13]
- [14] [14]
- [15] [15]
- [16] [16]
- [17] [17]
- [18] [18]
- [19] [19]
- [20] [20]
- [21] [21]
- [22] [22]
- [23] [23]
- [24] [24]
- [25] [25]

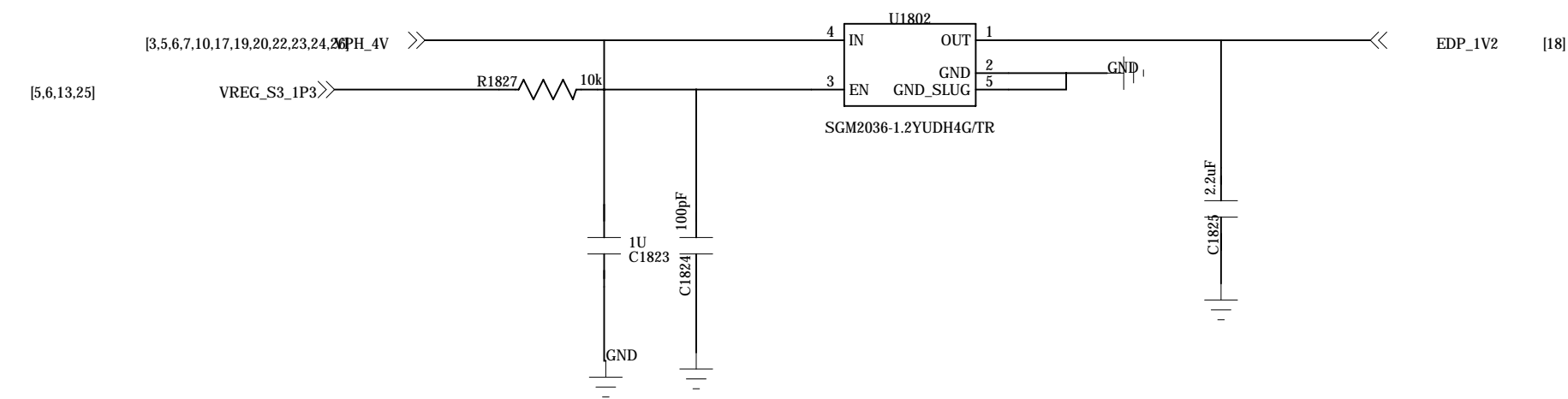

This is preliminary version, for reference only

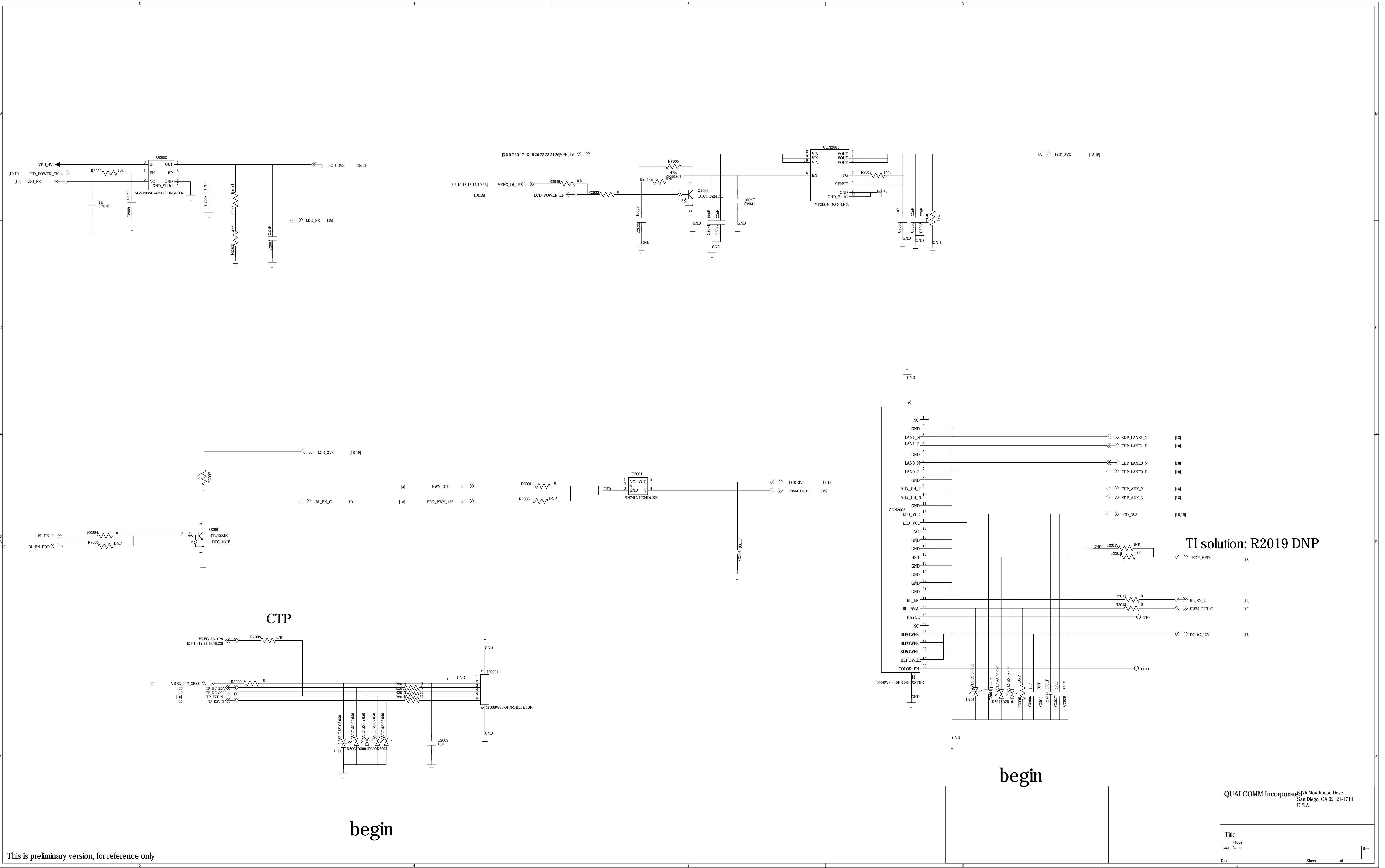

This is preliminary version, for reference only

begin

begin

TI solution: R2019 DNP

QUALCOMM Incorporated 1775 Morehouse Drive San Diego, CA 92121-1714 U.S.A.		
Title		
Sheet	Name	
Size	Rev	
Date:	Sheet	of

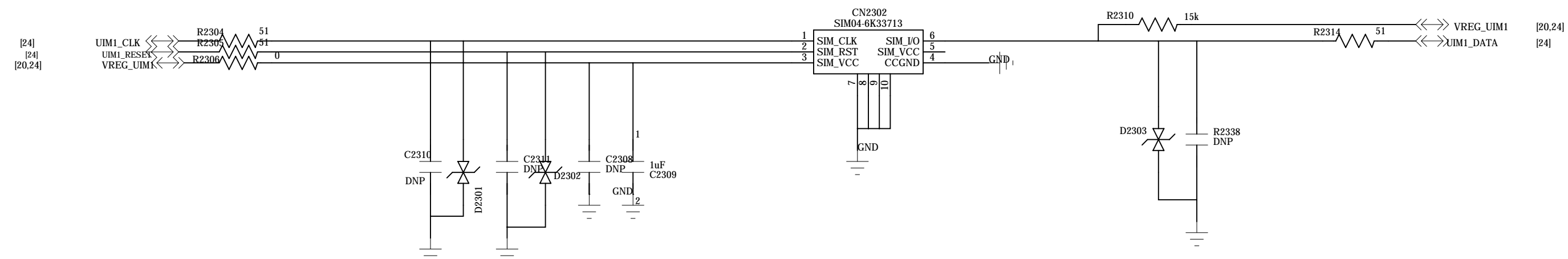
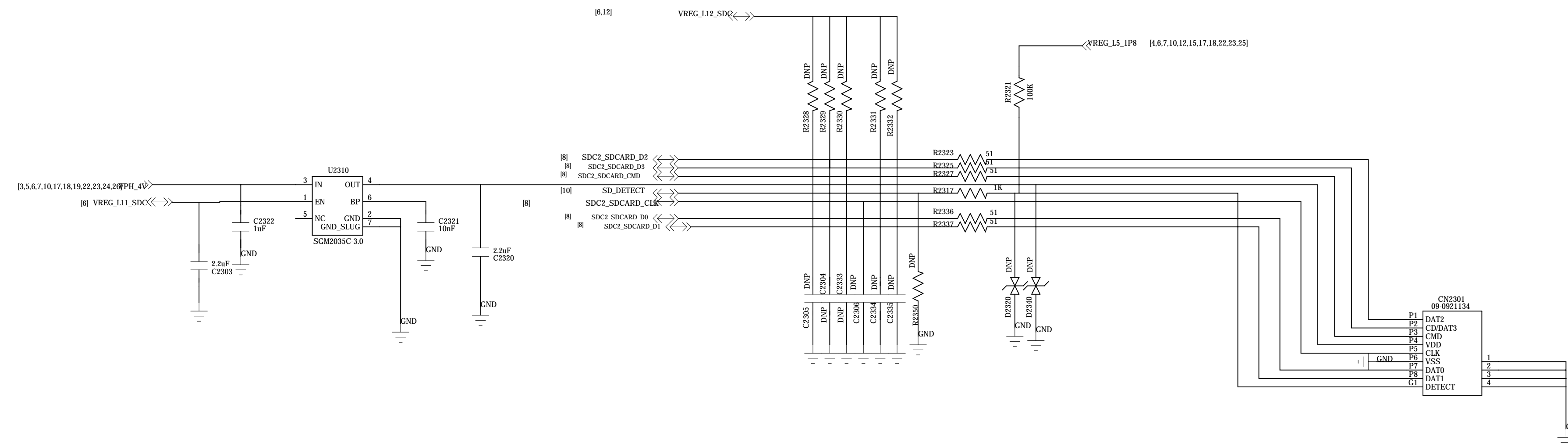

QUALCOMM Incorporated
 175 Morehouse Drive
 San Diego, CA 92121-1714
 U.S.A.

Title
 Sheet
 Size Name
 Date: _____ Sheet _____ of _____ Rev _____

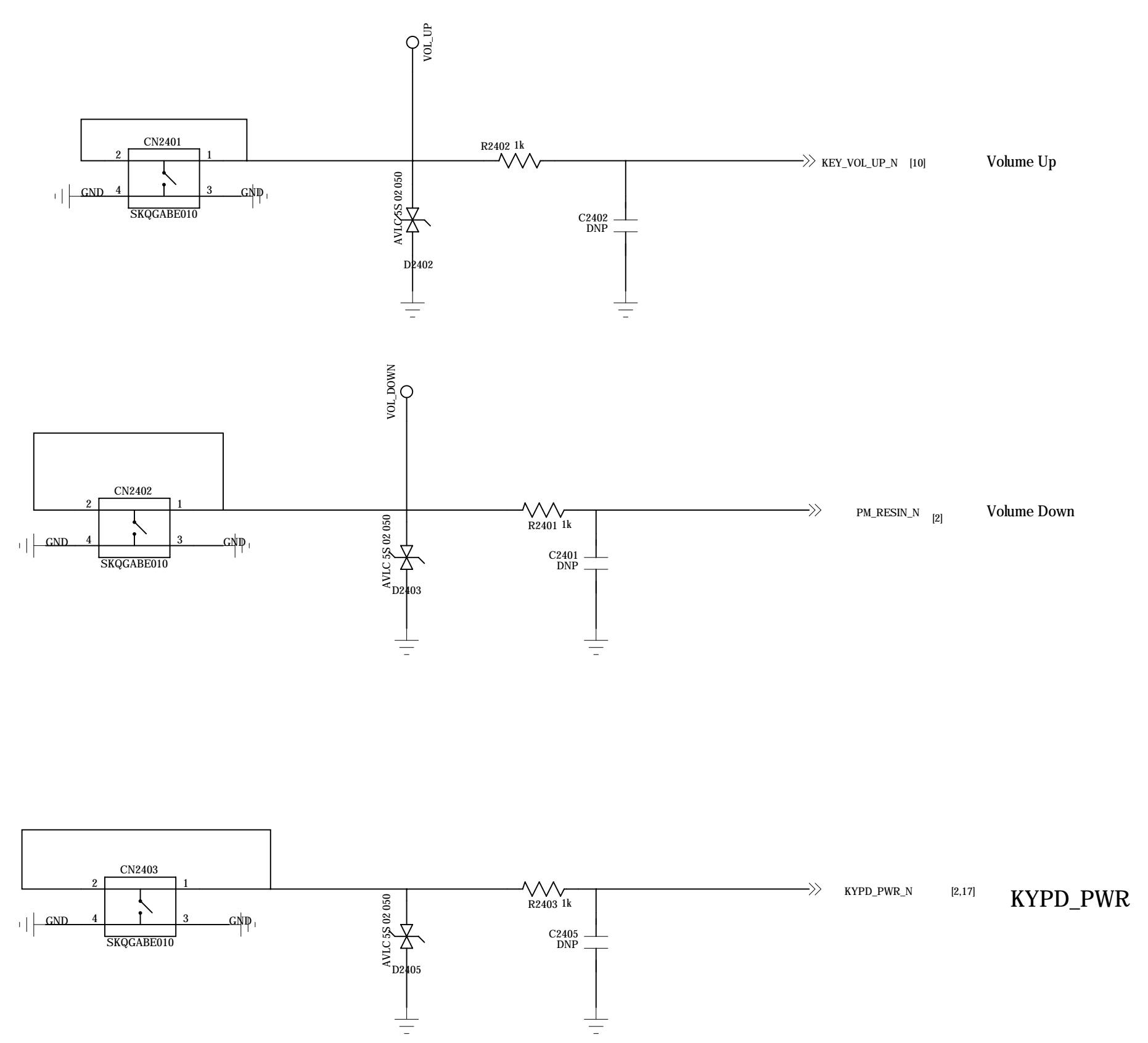

begin

NOT TO BE USED, COPIED, REPRODUCED IN WHOLE OR IN PART, NOR ITS CONTENTS REVEALED IN ANY MANNER TO OTHERS WITHOUT THE EXPRESS WRITTEN PERMISSION OF QUALCOMM.

QUALCOMM Incorporated 75 Morehouse Drive San Diego, CA 92121-1714 U.S.A.	
Title	
Sheet Size Name	Rev
Date: _____ Sheet _____ of _____	

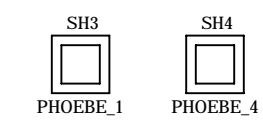
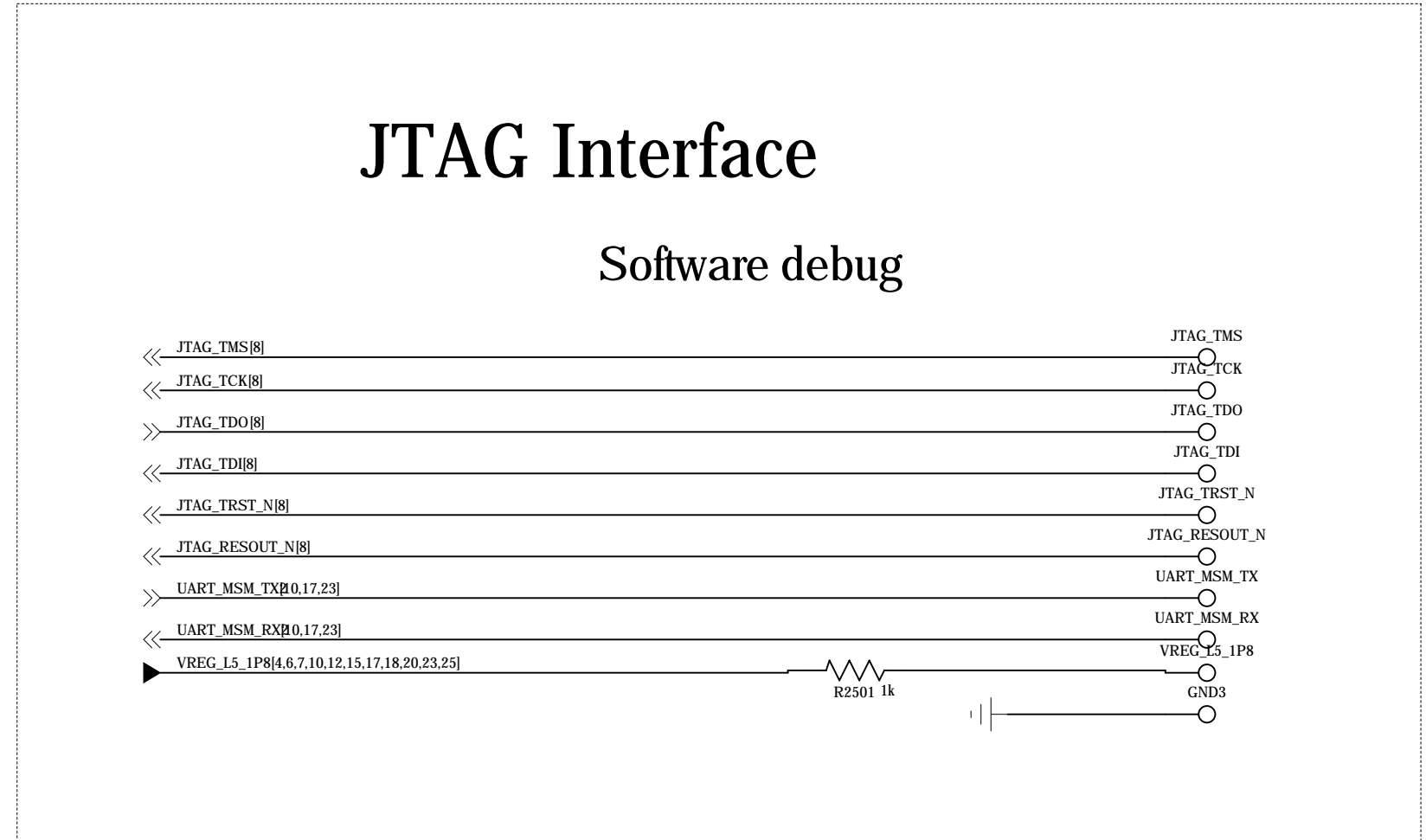
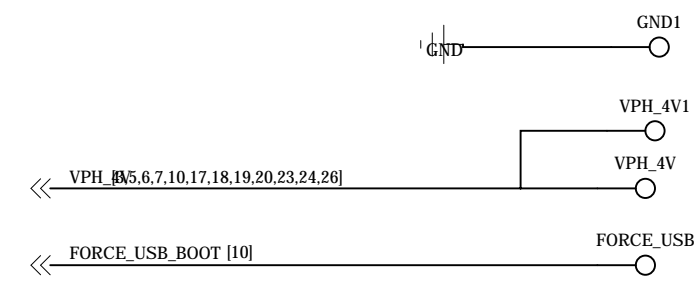

This is preliminary version, for reference only

QUALCOMM Incorporated 75 Morehouse Drive San Diego, CA 92121-1714 U.S.A.		
Title		
Sheet	of	Rev
Date:	Sheet	of

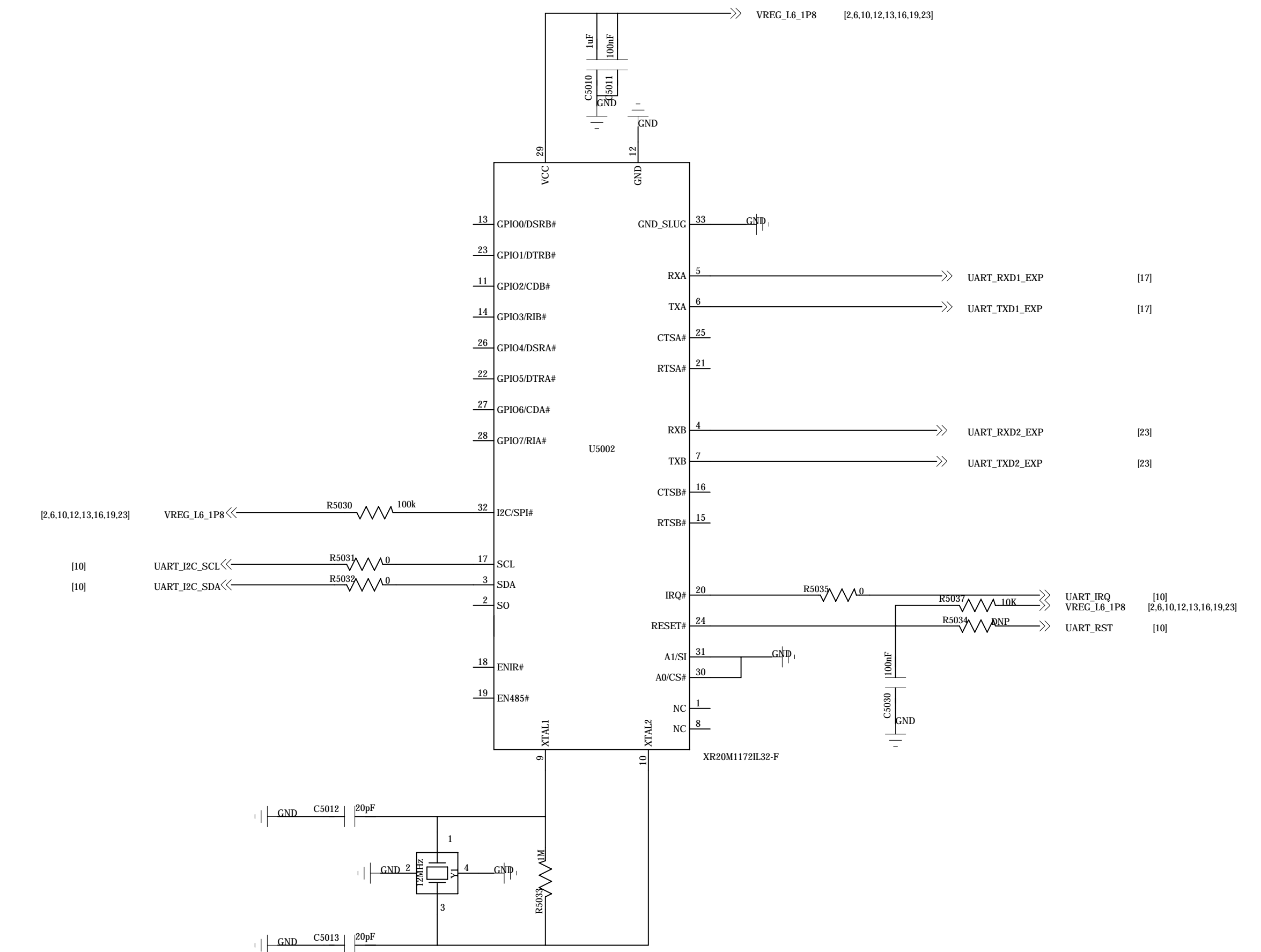
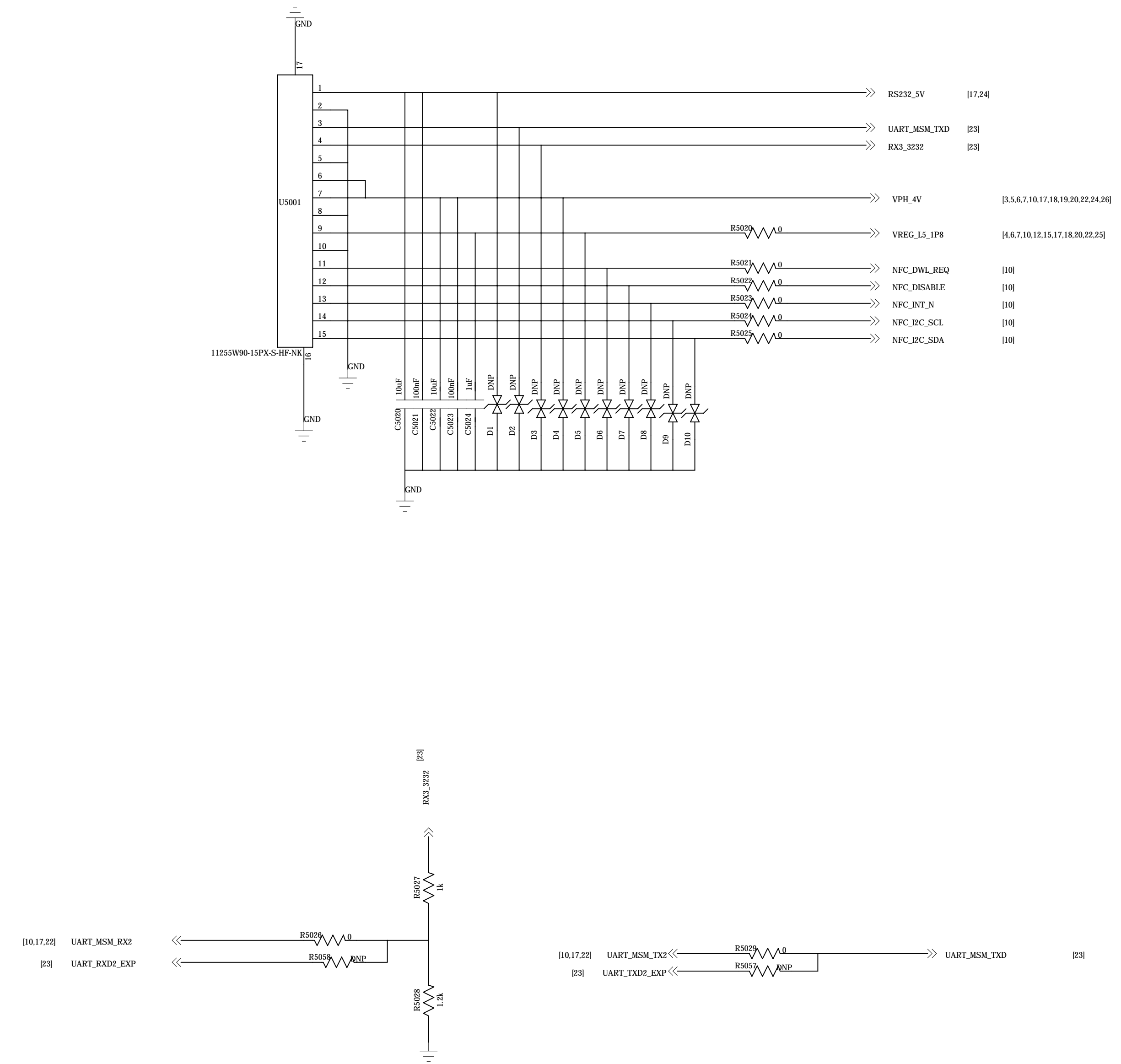

This is preliminary version, for reference only

NOT TO BE USED, COPIED, REPRODUCED IN WHOLE OR IN PART, NOR ITS CONTENTS REVEALED IN ANY MANNER TO OTHERS WITHOUT THE EXPRESS WRITTEN PERMISSION OF QUALCOMM.

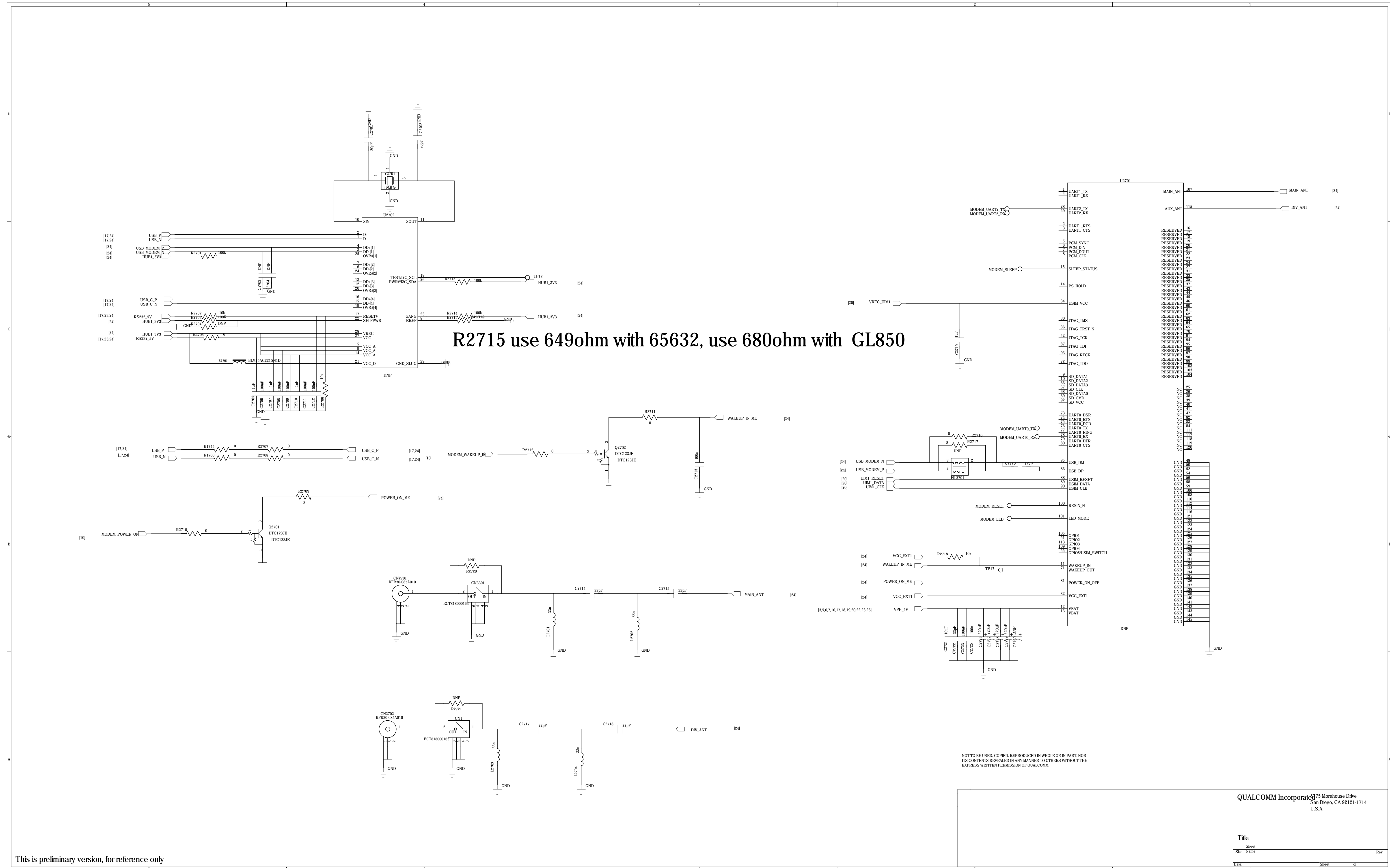

R2715 use 649ohm with 65632, use 680ohm with GL850

NOT TO BE USED, COPIED, REPRODUCED IN WHOLE OR IN PART, NOR ITS CONTENTS REVEALED IN ANY MANNER TO OTHERS WITHOUT THE EXPRESS WRITTEN PERMISSION OF QUALCOMM.

This is preliminary version, for reference only

QUALCOMM Incorporated
1175 Marchose Drive
San Diego, CA 92121-1714
U.S.A.

Title	
Sheet	Rev
Size	Name
Date:	Sheet of

NOTE THE CONNECTION

WIFI/BT

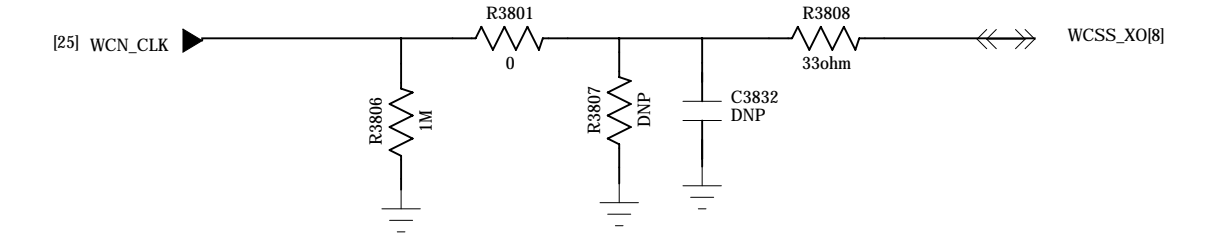
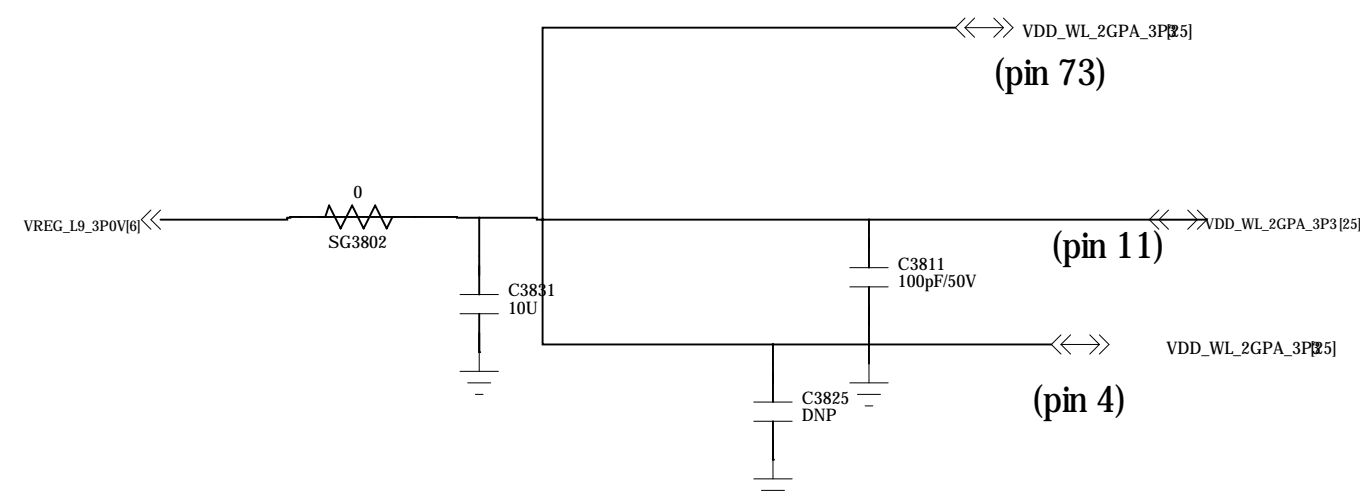
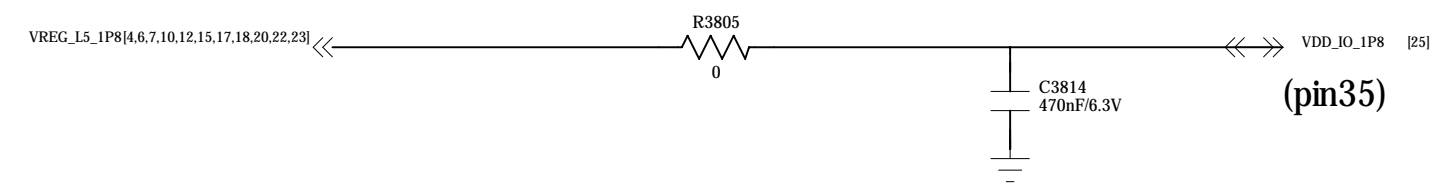
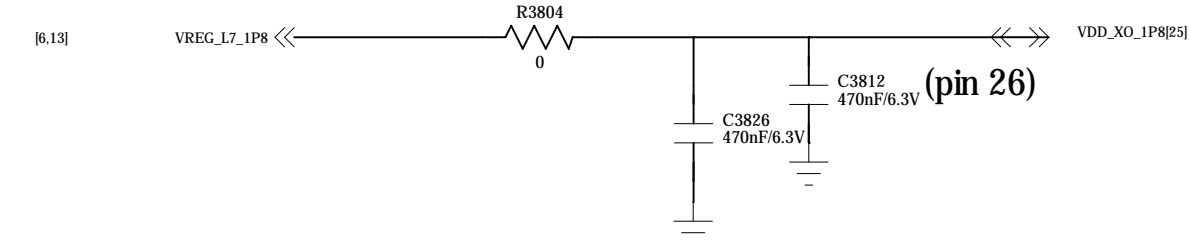
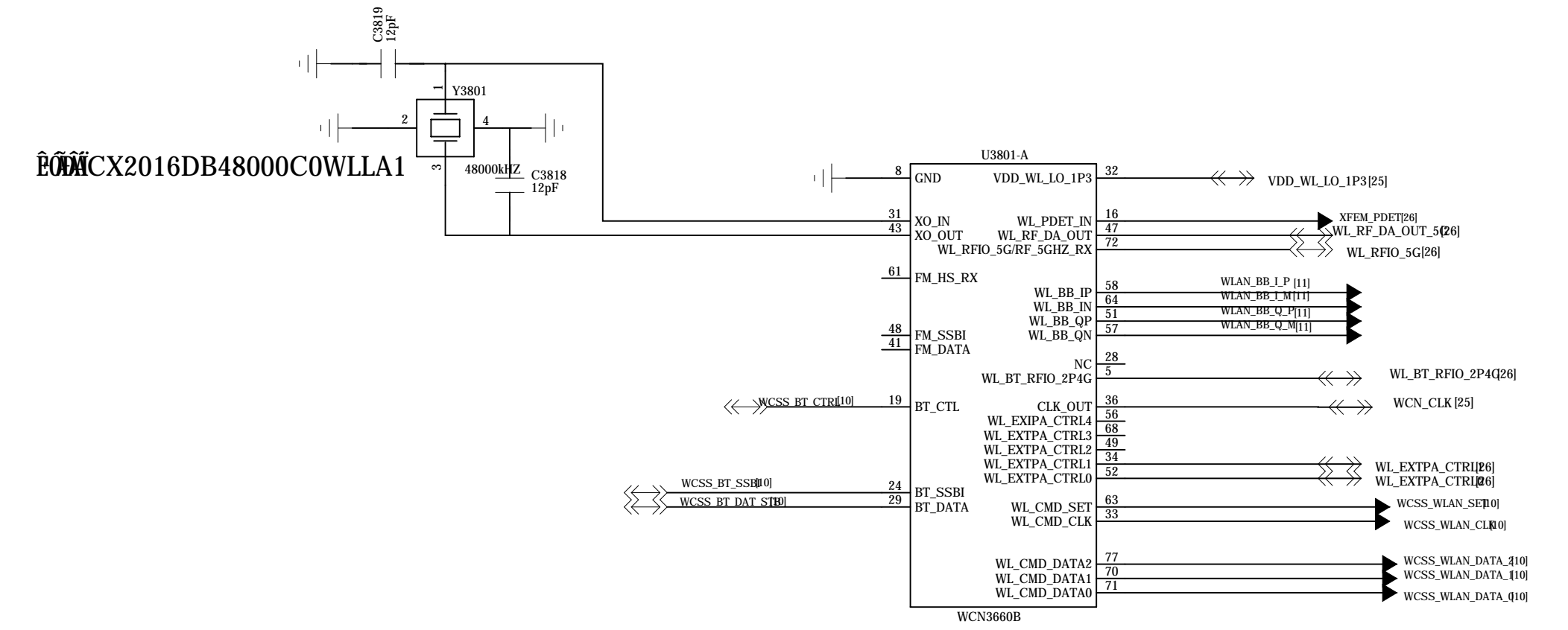
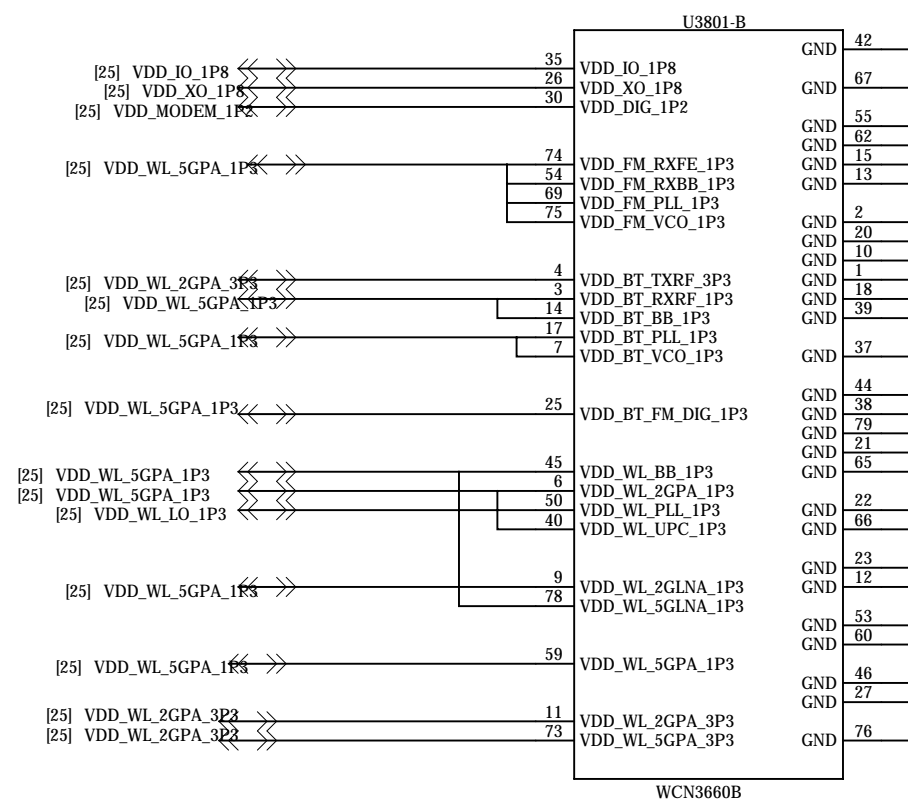
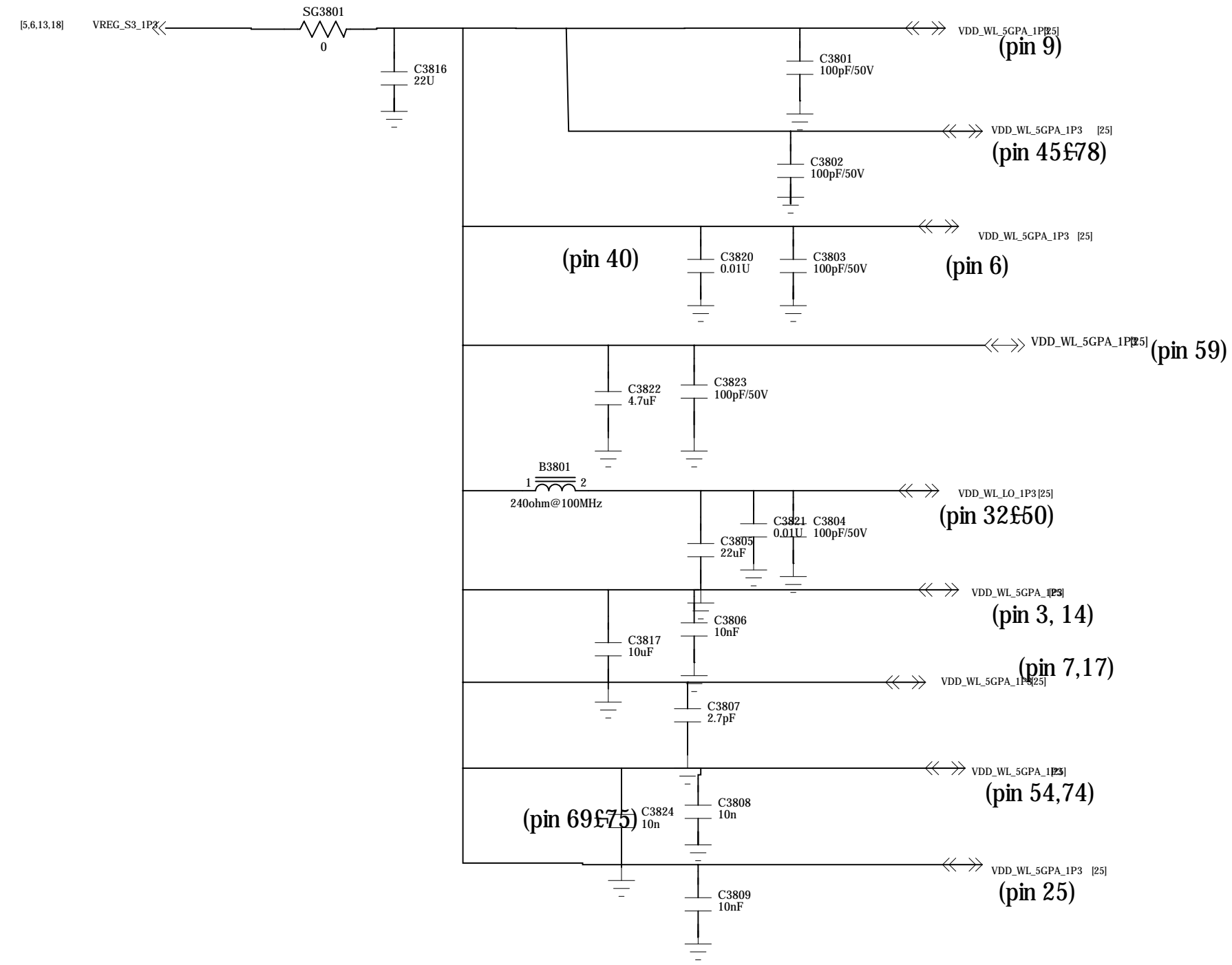

NOT TO BE USED, COPIED, REPRODUCED IN WHOLE OR IN PART, NOR ITS CONTENTS REVEALED IN ANY MANNER TO OTHERS WITHOUT THE EXPRESS WRITTEN PERMISSION OF QUALCOMM.

QUALCOMM Incorporated

5775 Marquette Drive
San Diego, CA 92121-1714
U.S.A.

Title		Rev
Size	Sheet	
1	1	

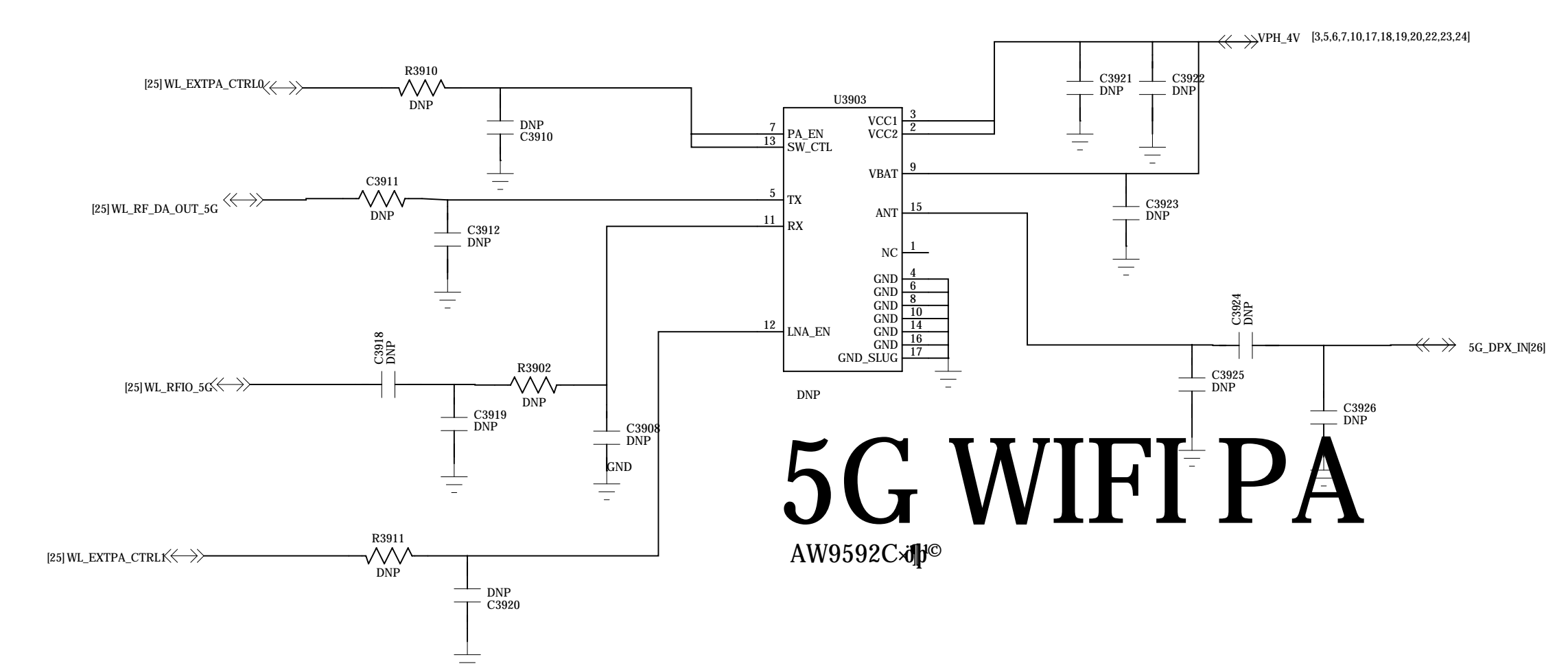
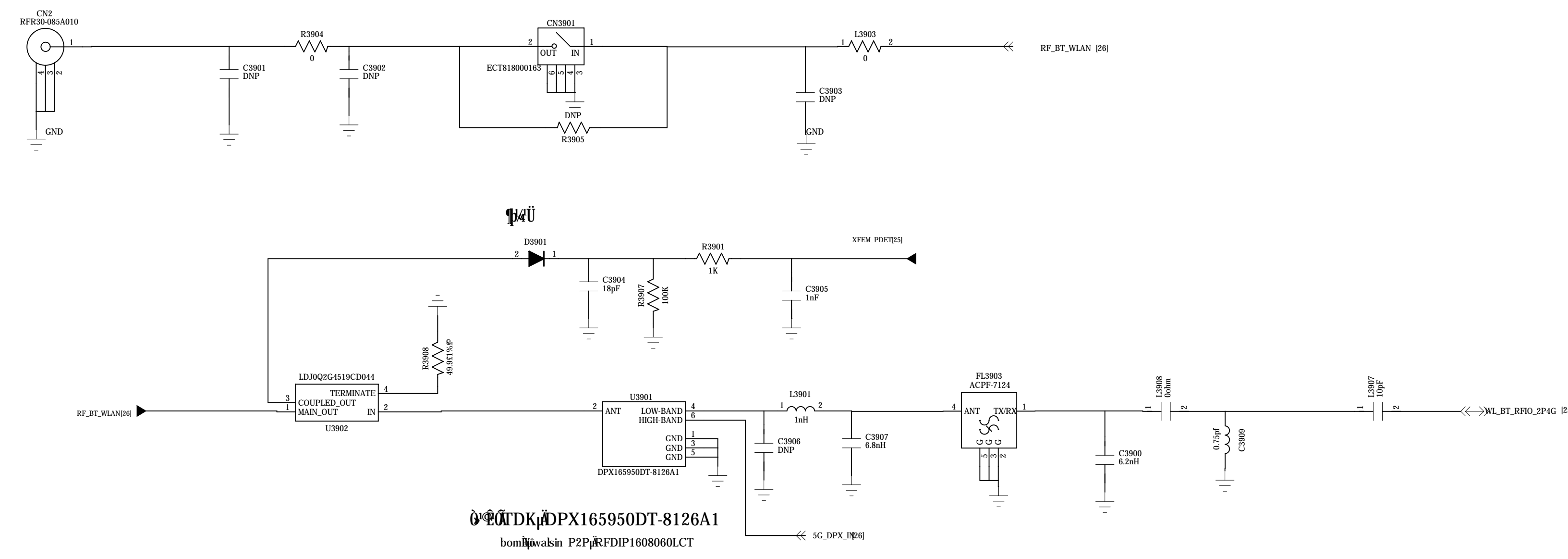

5G WIFI PA

AW9592C

NOT TO BE USED, COPIED, REPRODUCED IN WHOLE OR IN PART, NOR ITS CONTENTS REVEALED IN ANY MANNER TO OTHERS WITHOUT THE EXPRESS WRITTEN PERMISSION OF QUALCOMM.

QUALCOMM Incorporated
5775 Morehouse Drive
San Diego, CA 92121-1714
U.S.A.

Title		
Sheet	Name	Rev
1		