



TEST REPORT

No. I17D00245-EMC01

For

Client : Shanghai Sunmi Technology Co.,Ltd.

Production: POS System

Model Name : W1302

Hardware Version: B3.2

Software Version: SUNMI_T1mini_GLOBAL_000009_170913

FCC ID: 2AH25W1300

Issued date: 2018-01-15

Note:

The test results in this test report relate only to the devices specified in this report. This report shall not be reproduced except in full without the written approval of ECIT Shanghai.

Test Laboratory:

ECIT Shanghai, East China Institute of Telecommunications

Add: 7F, G Area, No.668, Beijing East Road, Huangpu District, Shanghai, P. R. China

Tel: (+86)-021-63843300, E-Mail: welcome@ecit.org.cn

Revision Version

Report Number	Revision	Date	Memo
I17D00245-EMC01	00	2018-01-03	Initial creation of test report
I17D00245-EMC01	01	2018-01-09	Second creation of test report
I17D00245-EMC01	02	2018-01-15	Third creation of test report

CONTENTS

- 1. TEST LABORATORY
- 1.1. TESTING LOCATION
- 1.2. TESTING ENVIRONMENT
- 1.3. PROJECT DATA
- 1.4. SIGNATURE.....
- 1.5. CLIENT INFORMATION
- 1.6. APPLICANT INFORMATION.....
- 1.7. MANUFACTURER INFORMATION.....
- 2. EQUIPMENT UNDER TEST (EUT) AND ANCILLARY EQUIPMENT (AE).....
- 2.1. ABOUT EUT.....
- 3.2. INTERNAL IDENTIFICATION OF EUT USED DURING THE TEST
- 3.3. INTERNAL IDENTIFICATION OF AE USED DURING THE TEST
- 4. REFERENCE DOCUMENTS
- 4.1 REFERENCE DOCUMENTS FOR TESTING
- 5. TEST RESULTS.....
- 5.1 SUMMARY OF TEST RESULTS
- 5.2 STATEMENTS.....
- 6. TEST EQUIPMENT UTILIZED.....
- 6.1 RADIATED EMISSION EQUIPMENT LIST
- 6.1 AC CONDUCTED EMISSION EQUIPMENT LIST
- 7. SYSTEM CONFIGURATION DURING TEST
- 7.1 TEST MODE.....
- 7.2 CONNECTION DIAGRAM OF TEST SYSTEM.....
- 8. MEASUREMENT RESULTS.....
- 8.1 RADIATED EMISSION 30MHZ-12.75GHZ

8.2 CONDUCTED EMISSION.....

1. Test Laboratory

1.1. Testing Location

Company Name: ECIT Shanghai, East China Institute of Telecommunications
Address: 7F, G Area, No. 668, Beijing East Road, Huangpu District, Shanghai,
P. R. China
Postal Code: 200001
Telephone: 86-21-63843300
Fax: 86-21-63843301
FCC registration No: 489729

1.2. Testing Environment

Normal Temperature: 15-35°C
Relative Humidity: 30-60%RH

1.3. Project data

Project Leader: Zhou Yan
Testing Start Date: 23-11, 2017
Testing End Date: 28-12, 2017

1.4. Signature



Tong Daocheng
(Prepared this test report)



You Jinjun
(Reviewed this test report)



Zheng Zhongbin
Director of the laboratory
(Approved this test report)

1.5. Client Information

1.6. Applicant Information

Company Name: Shanghai Sunmi Technology Co.,Ltd.
Address : Room 605, KIC Plaza, No.388 Song Hu Road, Yang Pu District,
Shanghai, China
Telephone: 18721763396
Post: 200433

1.7. Manufacturer Information

Company Name: Shanghai Sunmi Technology Co.,Ltd.
Address : Room 605, KIC Plaza, No.388 Song Hu Road, Yang Pu District,
Shanghai, China
Telephone: 18721763396
Post: 200433

2. Equipment under Test (EUT) and Ancillary Equipment (AE)

2.1. About EUT

EUT Description	POS System
Model name	W1302
Additional Communication Function	BT4.0;WIFI 802.11b,g,n

3.2. Internal Identification of EUT used during the test

EUT ID*	SN or IMEI	HW Version	SW Version	Date of receipt
N01	NA	B3.2	SUNMI_T1mini_GLOBAL _000009_170913	2017-11-01

*EUT ID: is used to identify the test sample in the lab internally.

3.3. Internal Identification of AE used during the test

AE ID*	Description	Model	SN	Remark
CA04	Adapter	EA10681P-240	NA	NA
CC01	Adapter	CYSE65-240250	NA	NA
UB01	Adapter Plug	POWER SUPPLY CORD PHP-301 TO PHS-301	NA	NA
UE01	Adapter Plug	HSC-203+HSC-213 1M BKOO	NA	NA
UF01	Adapter Plug	DTII-3P-11+04-1M	NA	NA
EA02	IOIOI Cable	NA	NA	NA
AE1	USB Cable	NA	NA	NA
AE2	LAN Cable	NA	NA	214cm
AE4	Cash Box	NA	NA	NA
AE5	Earphone	NA	NA	NA
AE6	Keyboard	KB212-B	CN-0Y88XT-65890-12 I-005Q-A00	NA
AE7	Mouse	MS111-P	CN-011D3V-71581-19 J-1A64	NA
AE8	Notebook PC	DELL Latitude E6510	NA	NA
AE9	SanDisk Ultra32GB	microSDHC UHS-I	NA	NA
AE10	U disk	DT101 G2	/	/

*AE ID: is used to identify the test sample in the lab internally.

4. Reference Documents

4.1 Reference Documents for testing

The following documents listed in this section are referred for testing.

Reference	Title	Version
FCC Part 15, Subpart B	Radio frequency devices	10-1-10 Edition
ANSI C63.4	Method of Measurement of Radio-Noise Emissions from Low-Voltage Electrical and Electronic Equipment in the Range of 9 kHz to 40 GHz	2014

5. Test Results

5.1 Summary of Test Results

Items	Test List	Clause in FCC rules	Verdict
1	Radiated Emission	15.109(a)	Pass
2	Conducted Emission	15.107(a)	Pass

5.2 Statements

The W1302, supporting BT/WLAN, manufactured by Shanghai Sunmi Technology Co.,Ltd. is a variant product for testing. ECIT only performed test cases which identified with Pass/Fail/Inc result in section 5.1.

ECIT has verified that the compliance of the tested device specified in section 3 of this test report is successfully evaluated according to the procedure and test methods as defined in type certification requirement listed in section 4 of this test report.

6. Test Equipment Utilized

6.1 Radiated Emission Equipment list

No.	Name	Type	Series Number	Producer	Cal. Date	Cal. interval
1	Universal Radio Communication	CMU200	123126	R&S	2017-05-11	1 Year
2	Test Receiver	ESU40	100307	R&S	2017-05-11	1 Year
3	Trilog Antenna	VULB9163	VULB9163-515	Schwarzbeck	2017-02-25	3 Year
4	Double Ridged Guide	ETS-3117	00135885	ETS	2017-01-11	3 Year
5	EMI Test Software	EMC32 V9.15	NA	R&S	NA	NA

6.1 AC Conducted Emission Equipment list

No.	Name	Type	Series Number	Producer	Cal. Date	Cal. interval
1	Universal Radio	CMU200	123123	R&S	2017-05-11	1 Year
2	Test Receiver	ESCI	101235	R&S	2017-05-11	1 Year
3	2-Line V-Network	ENV216	101380	R&S	2017-05-11	1 Year
4	EMI Test Software	EMC32 V9.15	NA	R&S	NA	NA

7. System Configuration during Test

7.1 Test Mode

Test Item	Function Type
AC Conducted Emission	Mode 1: Charge Mode +CA04+ UB01 Mode 2: Charge Mode +CC01+ UE01 Mode 3: Charge Mode +CC01+ UF01 Mode 4: Data link mode with PC
Radiated Emission	Mode 1: Charge Mode +CA04+ UB01 Mode 2: Charge Mode +CC01+ UE01 Mode 3: Charge Mode +CC01+ UF01 Mode 4: Data link mode with PC
Remark: 1.All test modes are performed, only the worst cases test data are recorded in this report. 2.Data Link with PC means data application transferred mode between EUT and PC.	

7.2 Connection Diagram of Test System

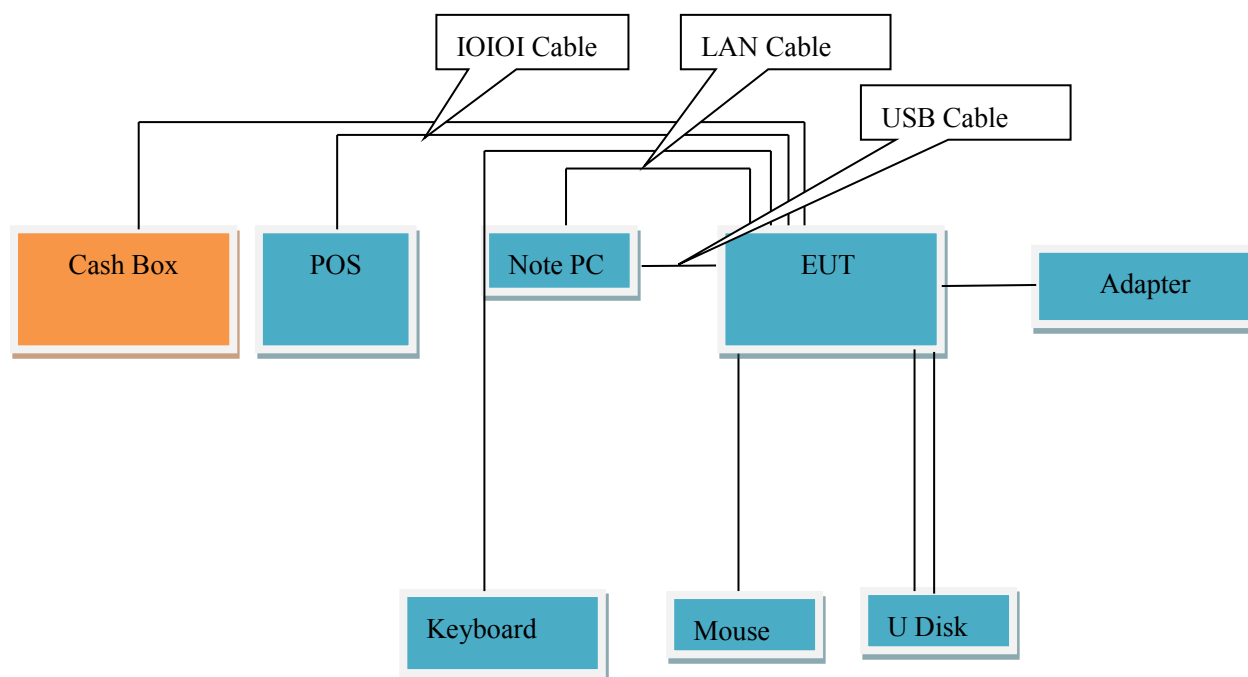

<Figure 1>

8. Measurement Results

Only the worst test result was shown in this report.

8.1 Radiated Emission 30MHz-12.75GHz

Method of Measurement

For 30-1000MHz, the EUT was placed on the top of a rotating 0.8-m table above the ground at a semi-anechoic chamber. The distance between the EUT and the received antenna was 3 meters. The table was rotated 360 degree and the received antenna mounted on a variable-height antenna tower was varied from 1m to 4m to find the maximum value of the field strength. Both horizontal and vertical polarizations of the antenna were set during the measurement. Tested in accordance with the procedures of ANSI C63.4-2014, section 8.3.

For 1000-12750MHz, The maximal emission value was acquired by adjusting the antenna height, The table was rotated 360 degree to determine the maximum value of the field strength. Both horizontal and vertical polarizations of the antenna were set during the measurement.

Limits for Radiated Emission at a measuring distance of 3m

Frequency Range (MHz)	Quasi-Peak (dBuV/m)
30-88	40
88-216	43.5
216-960	46
Above 960	54

Frequency Range (MHz)	Peak (dBuV/m)	Average (dBuV/m)
Above 1000	74	54

Test conditions

Frequency Range (MHz)	RBW/VBW	Sweep Time (s)
30-1000	120KHz/300KHz	Auto
1000-12750	1MHz/3MHz	Auto

Uncertainty Measurement

The measurement uncertainty(30MHz-1000MHz) is 5.48 dB (k=2).

The measurement uncertainty(1000MHz-6000MHz) is 5.20 dB (k=2).

Test Results

Mode 4: Data link mode with PC

Frequency Range:

30MHz – 1GHz

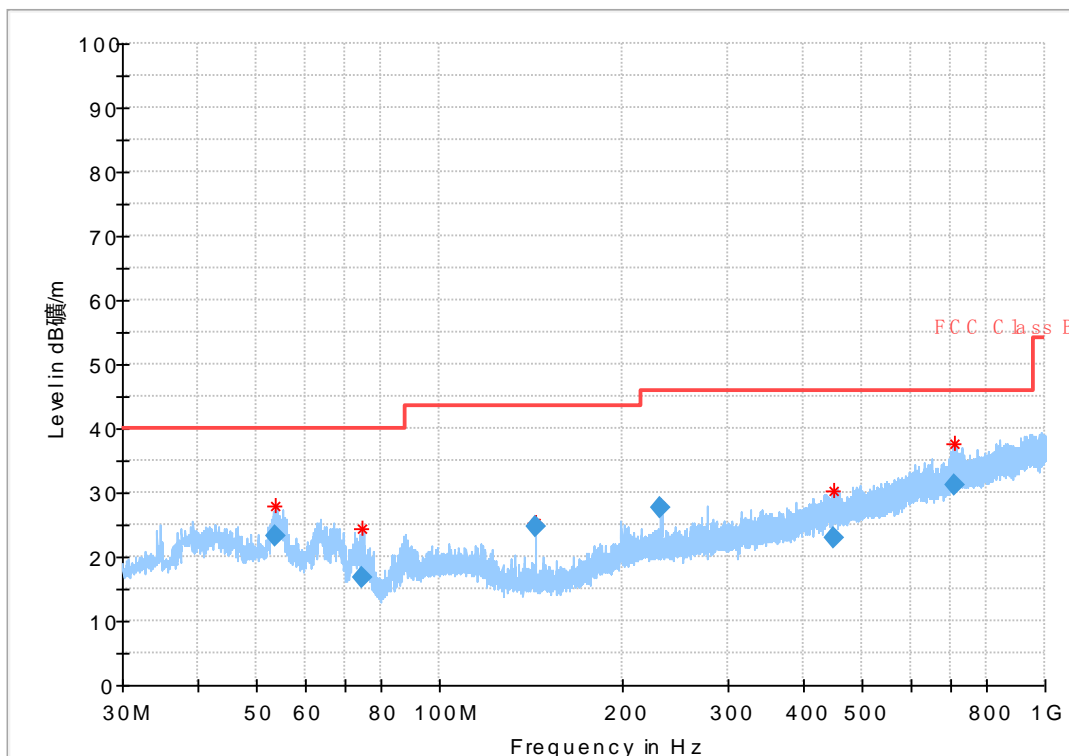

Frequency (MHz)	QuasiPeak (dB/m)	Limit (dB/m)	Margin (dB)	Meas. Time (ms)	Bandwidth (kHz)	Height (cm)	Pol	Azimuth (deg)	Corr. (dB)
53.817691	23.31	40.00	16.69	1000.0	120.000	100.0	V	20.0	-9.8
74.629960	16.89	40.00	23.11	1000.0	120.000	100.0	V	53.0	-13.9
144.017480	24.80	43.50	18.70	1000.0	120.000	225.0	H	68.0	-14.1
232.378995	27.79	46.00	18.21	1000.0	120.000	175.0	H	217.0	-8.7
447.591072	23.05	46.00	22.95	1000.0	120.000	175.0	V	270.0	-2.5
708.679509	31.13	46.00	14.87	1000.0	120.000	125.0	H	29.0	2.9

Note:

1. Emission level(QP)=Raw value by receiver + Corr(Antenna factor + cable loss - preamplifier gain)
2. The raw value is used to calculate by software which is not shown in the sheet.
3. Margin=limit value – emission level.

Mode 4: Data link mode with PC

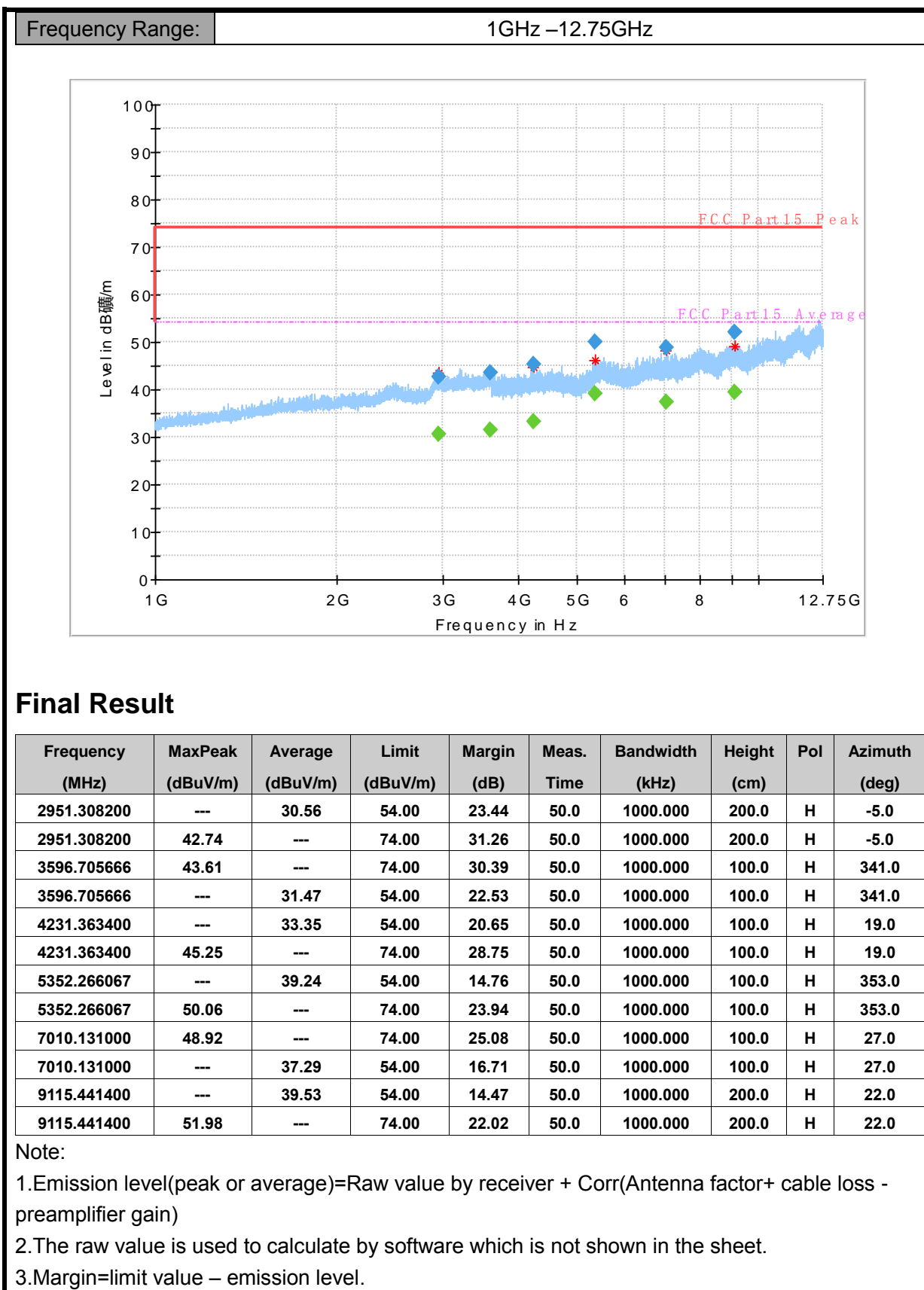

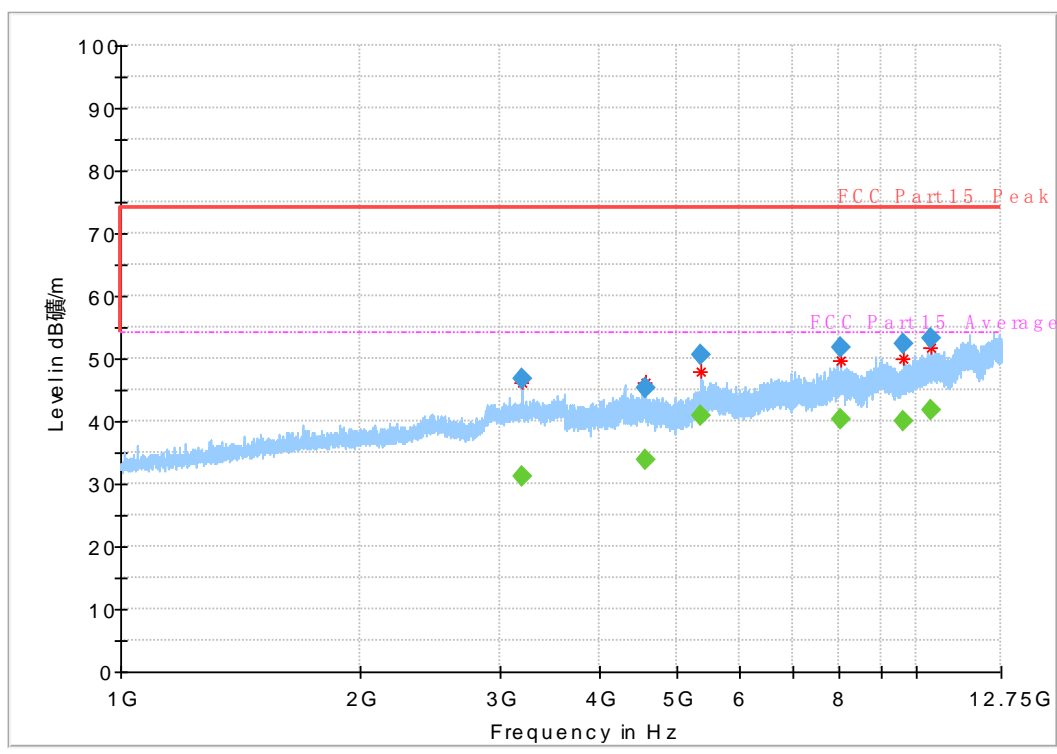

Final Result

Frequency (MHz)	MaxPeak (dBuV/m)	Average (dBuV/m)	Limit (dBuV/m)	Margin (dB)	Meas. Time	Bandwidth (kHz)	Height (cm)	Pol	Azimuth (deg)
3197.574266	---	31.08	54.00	22.92	50.0	1000.000	100.0	V	-8.0
3197.574266	46.79	---	74.00	27.21	50.0	1000.000	100.0	V	-8.0
4555.521733	45.41	---	74.00	28.59	50.0	1000.000	100.0	V	13.0
4555.521733	---	33.87	54.00	20.13	50.0	1000.000	100.0	V	13.0
5352.646267	50.73	---	74.00	23.27	50.0	1000.000	100.0	V	88.0
5352.646267	---	40.92	54.00	13.08	50.0	1000.000	100.0	V	88.0
8029.572333	51.79	---	74.00	22.21	50.0	1000.000	100.0	V	269.0
8029.572333	---	40.19	54.00	13.81	50.0	1000.000	100.0	V	269.0
9603.707600	52.21	---	74.00	21.79	50.0	1000.000	200.0	V	22.0
9603.707600	---	40.10	54.00	13.90	50.0	1000.000	200.0	V	22.0
10427.778000	---	41.62	54.00	12.38	50.0	1000.000	100.0	V	341.0
10427.778000	53.25	---	74.00	20.75	50.0	1000.000	100.0	V	341.0

Note:

- 1.Emission level(peak or average)=Raw value by receiver + Corr(Antenna factor+ cable loss - preamplifier gain)
- 2.The raw value is used to calculate by software which is not shown in the sheet.
- 3.Margin=limit value – emission level.

8.2 Conducted Emission

Method of Measurement

For equipment that is designed to be connected to the public utility (AC) power line, the radio frequency voltage that is conducted back onto the AC power line on any frequency or frequencies with the band 150 kHz to 30MHz shall not exceed the limits. Both lines of the power mains connected to the EUT were checked for maximum conducted interference. Tested in accordance with the procedures of ANSI C63.4-2014, section 7.3

Limit of Conducted Emission

Frequency Range (MHz)	Conducted Limit (dBuV)	
	Quasi-peak	Average
0.15-0.5	66 to 56*	56 to 46*
0.5-5	56	46
5-30	60	50

*Decreases with the logarithm of the frequency

Test Condition in Charging Mode

Voltage (V)	Frequency (Hz)	RBW	Sweep Time (s)
120	60	9 kHz	Auto

Uncertainty Measurement

The measurement uncertainty is 3.68dB (k=2).

Test Results

Mode 2: Charge Mode +CC01+ UE01

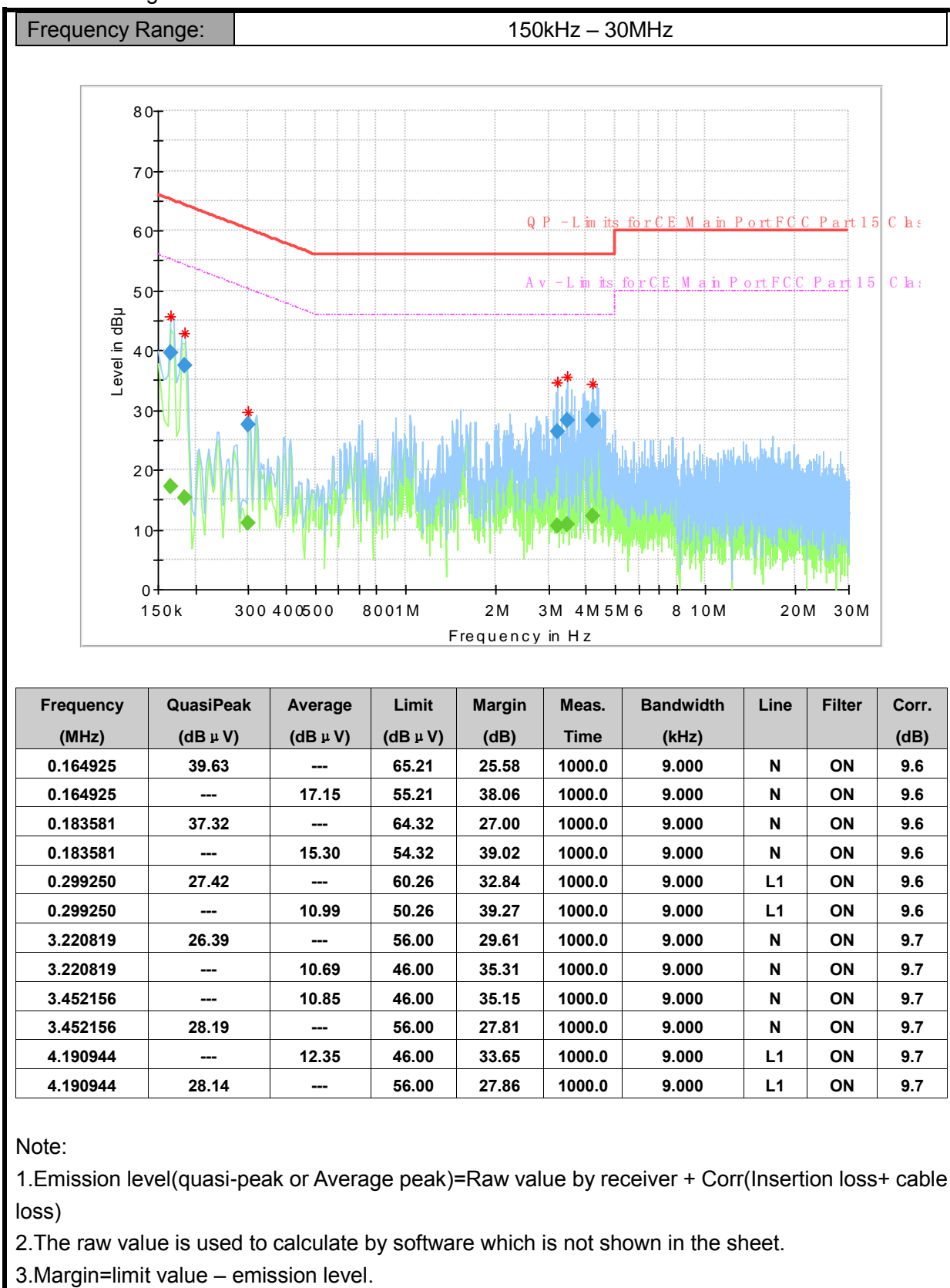

*****END OF REPORT*****