



TEST REPORT

Report Number: C21T00097-SRD04-V01

Applicant	Shanghai Sunmi Technology Co.,Ltd.
Product Name	Handheld Wireless Terminal
Model Name	T8A10
Brand Name	SUNMI
FCC ID	2AH25T8A10
IC	22621-T8A10

Industrial Internet Innovation Center (Shanghai) Co., Ltd. tested the above equipment in accordance with the requirements in FCC Part15, ANSI C63.10-2013, KDB 558074, RSS-Gen Issue 5, RSS-247 Issue 2.

Prepared by

Reviewed by

Approved by

Issue Date

2021-12-17

Industrial Internet Innovation Center (Shanghai) Co., Ltd.



NOTE

1. This report is invalid without the signature of the writer, reviewer and authorizer.
2. This report is invalid if altered.
3. For the benefit of clients, if you have any objection to the report, please inform the testing laboratory within 15 days from the date of receiving this report.
4. Samples in the test report are provided by the client. The test results are only applicable to the samples received by the laboratory. The source information of samples (such as sample sender, manufacturer, etc.) in the test report is provided by the client, and the laboratory is not responsible for its authenticity and the measurement accuracy.
5. The test report does not represent the identification of a product by a certification body or an authorized body.
6. This report is only valid as a whole, and no part of the report can be reproduced without the written approval of Industrial Internet Innovation Center (Shanghai) Co., Ltd.
7. Without the written permission of testing institutions and accreditation bodies, this report cannot be used in part or in whole for publicity or product introduction.
8. "N/A" is used in this report to indicate that it is not applicable or available.
9. Industrial Internet Innovation Center (Shanghai) Co., Ltd. assumes the legal responsibility for the report.
10. The measurement uncertainty is not taken into account when deciding conformity, and the results of measurement (or the average of measurement results) are directly used as the criterion for the stating conformity.

Test Laboratory:

Industrial Internet Innovation Center (Shanghai) Co., Ltd.

Add: Building 4, No. 766 Jingang Rd, Pudong, Shanghai, China

Tel: +86 21 68866880



Revision Version

Report Number	Revision	Date	Memo
C21T00097-SRD04-V00	00	2021-11-12	Initial creation of test report
C21T00097-SRD04-V01	01	2021-12-17	<ol style="list-style-type: none">1. FCC Rule Part Version has been update.2. RSS-GEN issue date has been update.3. A description has been added in 6.6.3 and 6.7 chapter.



CONTENTS

1. TEST LABORATORY.....	6
1.1. TESTING LOCATION.....	6
1.2. TESTING ENVIRONMENT.....	6
1.3. PROJECT INFORMATION.....	6
2. CLIENT INFORMATION.....	7
2.1. APPLICANT INFORMATION.....	7
2.2. MANUFACTURER INFORMATION.....	7
3. EQUIPMENT UNDER TEST (EUT) AND ANCILLARY EQUIPMENT (AE).....	8
3.1. ABOUT EUT.....	8
3.2. INTERNAL IDENTIFICATION OF EUT USED DURING THE TEST.....	8
3.3. INTERNAL IDENTIFICATION OF AE USED DURING THE TEST.....	8
4. REFERENCE DOCUMENTS.....	9
4.1. REFERENCE DOCUMENTS FOR TESTING.....	9
4.2. REFERENCE INFORMATION FROM CLIENT.....	9
5. TEST SUMMARY.....	10
5.1. SUMMARY OF TEST RESULTS.....	10
5.2. STATEMENTS.....	11
6. MEASUREMENT RESULTS.....	12
6.1. MAXIMUM OUTPUT POWER.....	13
6.2. PEAK POWER SPECTRAL DENSITY.....	19
6.3. OCCUPIED 26DB BANDWIDTH(CONDUCTED).....	24
6.4. 99% OCCUPIED BANDWIDTH(CONDUCTED).....	29
6.5. BAND EDGES COMPLIANCE.....	34



6.6. TRANSMITTER SPURIOUS EMISSION.....	42
6.7. FREQUENCY STABILITY.....	57
7. TEST EQUIPMENT LIST.....	58
7.1. CONDUCTED TEST SYSTEM.....	58
7.2. RADIATED EMISSION TEST SYSTEM.....	58
ANNEX A: ACCREDITATION CERTIFICATE.....	60

1. Test Laboratory

1.1. Testing Location

Primary Lab:

Company Name	Industrial Internet Innovation Center (Shanghai) Co., Ltd.
Address	Building 4, No. 766 Jingang Rd, Pudong, Shanghai, China
FCC Registration No.	958356
FCC Designation No.	CN1177
IC designation No.	CN0067

Subcontracting Lab #1:

Company Name	N/A
Address	N/A

1.2. Testing Environment

Normal Temperature	15°C~35°C
Relative Humidity	30%RH~60%RH
Supply Voltage	120V/60Hz

1.3. Project Information

Project Leader	Wang Wenwen
Testing Start Date	2021-08-05
Testing End Date	2021-10-22



2. Client Information

2.1. Applicant Information

Company Name	Shanghai Sunmi Technology Co.,Ltd.
Address	Room 505, KIC Plaza, No.388 Song Hu Road, Yang Pu District, Shanghai, China
Telephone	+86 18501703215

2.2. Manufacturer Information

Company Name	Shanghai Sunmi Technology Co.,Ltd.
Address	Room 505, KIC Plaza, No.388 Song Hu Road, Yang Pu District, Shanghai, China
Telephone	+86 18501703215

3. Equipment under Test (EUT) and Ancillary Equipment (AE)

3.1. About EUT

Product Name	Handheld Wireless Terminal
Model name	T8A10
Supported Radio Technology and Bands	GSM850/GSM900/DCS1800/PCS1900 WCDMA Band I/III/ IV/V/VIII LTE Band 1/2/3/4/5/7/12/13/17/18/19/25/26/38/41/66/71 BT 5.0,BLE WLAN 802.11b,g,n WLAN 802.11a,n,ac NFC GPS
Hardware Version	V4
Software Version	V025
WLAN Frequency	U-NII-1:5150 MHz~5250 MHz
FCC ID	2AH25T8A10
IC	22621-T8A10

3.2. Internal Identification of EUT used during the test

EUT ID*	SN or IMEI	HW Version	SW Version	Date of Receipt
N01	866584051015648 866584051015655	V4	V025	2021-08-04
N02	866584051015721 866584051015739	V4	V025	2021-08-04
N08	866584051015747 866584051015754	V4	V025	2021-08-04

*EUT ID: is internally used to identify the test sample in the lab.

3.3. Internal Identification of AE used during the test

AE ID*	Description	Model	SN/Remark
AE1	RF Cable	N/A	N/A

*AE ID: is internally used to identify the test sample in the lab.

*The AE is provided by the client.

4. Reference Documents

4.1. Reference Documents for testing

The following documents listed in this section are referred for testing.

Reference	Title	Version
FCC Part15	Title 47 of the Code of Federal Regulations; Chapter I Part 15 - Radio frequency devices	2020-10-01
ANSI 63.10	Methods of Measurement of Radio-Noise Emissions from Low-Voltage Electrical and Electronic Equipment in the Range of 9 kHz to 40 GHz	2013
KDB 789033	Information Infrastructure (U-NII) Devices - Part 15, Subpart E	2017
KDB 905462	COMPLIANCE MEASUREMENT PROCEDURES FOR UNLICENSED-NATIONAL INFORMATION INFRASTRUCTURE DEVICES OPERATING IN THE 5250-5350 MHz AND 5470-5725 MHz BANDS INCORPORATING DYNAMIC FREQUENCY SELECTION	2016
RSS-247 Issue 2	Digital Transmission Systems (DTSs), Frequency Hopping Systems (FHSs) and Licence-Exempt Local Area Network (LE-LAN) Devices	2017
RSS-Gen Issue 5	General Requirements for Compliance of Radio Apparatus	2021

4.2. Reference Information from client

Information of the test sample provided by the client.

Antenna gain of EUT 3 dBi

Note: The product T8A10 use an integral antenna which compliance with the requirement of 15.203.

5. Test Summary

5.1. Summary of Test Results

Measurement Items	Sub-clause of Part15C	Sub-clause of IC	Verdict
Maximum Output Power	15.407(a)	RSS-247 6.2	Pass
Power Spectral Density	15.407(a)	RSS-247 6.2	Pass
99% Occupied Bandwidth	N/A	RSS-Gen 6.7	Pass
-26dB	15.407(a)	RSS-247 6.2	Pass
Band edge compliance	15.407(b)	RSS-247 6.2	Pass
Transmitter spurious emissions radiated	15.407(b)	RSS-247 6.2	Pass
Spurious emissions radiated < 30 MHz	15.209 & 15.407(b)	RSS-247 6.2 RSS-Gen 8.9,8.10	Pass
Spurious emissions conducted < 30 MHz	15.407(b)	RSS-247 6.2	Pass
Frequency Stability	15.407(g)	RSS-Gen 8.11	Pass
Transmit Power Control	15.407(h)	RSS-247 6.2	N/A

Test Conditions

Tnom	Normal Temperature
Tmin	Low Temperature
Tmax	High Temperature
Vnom	Normal Voltage
Vmin	Low Voltage
Vmax	High Voltage
Hnom	Norm Humidity
Anom	Norm Air Pressure

For this report, all the test case listed above are tested under Normal Temperature and Normal Voltage, and also under norm humidity, the specific conditions as following:

Temperature	Tnom	25°C
Voltage	Vnom	3.8V
Humidity	Hnom	48%
Air Pressure	Anom	1010hPa

Note:

- a. All the test data for each data were verified, but only the worst case was reported.
- b. The DC and low frequency voltages' measurement uncertainty is $\pm 2\%$.



5.2. Statements

The T8A10 manufactured by Shanghai Sunmi Technology Co.,Ltd., Incorporated are new products for testing.

Industrial Internet Innovation Center (Shanghai) Co., Ltd. only performed test cases which identified with Pass/Fail/Inc result in section 5.1.

Industrial Internet Innovation Center (Shanghai) Co., Ltd. has verified that the compliance of the tested device specified in section 3 of this test report is successfully evaluated according to the procedure and test methods as defined in type certification requirement listed in section 4 of this test report.

6. Measurement Results

Shielding Room1 (6.0 meters×3.0 meters×2.7 meters) did not exceed following limits along the conducted RF performance testing:

Temperature	Min. = 15 °C, Max. = 35 °C
Relative humidity	Min. = 20 %, Max. = 75 %
Shielding effectiveness	> 100 dB
Ground system resistance	< 0.5
Temperature	Min. = 15 °C, Max. = 35 °C

Control room did not exceed following limits along the EMC testing:

Temperature	Min. = 15 °C, Max. = 35 °C
Relative humidity	Min. =30 %, Max. = 60 %
Shielding effectiveness	> 100 dB
Electrical insulation	> 10 k
Ground system resistance	< 0.5

Fully-anechoic chamber1 (6.9 meters×10.9 meters×5.4 meters) did not exceed following limits along the EMC testing:

Temperature	Min. = 15 °C, Max. = 35 °C
Relative humidity	Min. = 25 %, Max. = 75 %
Shielding effectiveness	> 100 dB
Electrical insulation	> 10 k
Ground system resistance	< 0.5
VSWR	Between 0 and 6 dB, from 1GHz to 18GHz
Site Attenuation Deviation	Between -4 and 4 dB,30MHz to 1GHz
Uniformity of field strength	Between 0 and 6 dB, from 80MHz to 3000 MHz

6.1. Maximum output Power

6.1.1. Measurement Limit and Method

Standard	Limit (dBm)
FCC 47 CFR Part 15.407(a)(1)(iv)	23 or $10+10 \log_{10}B$
RSS-247 6.2.1.1	23 or $10+10 \log_{10}B$

Limit use the less value, and B is the 26dB bandwidth.

6.1.2. The measurement method SA-1 is made according to KDB 789033

Set the spectrum analyzer in the following:

Detector: RMS.

RBW=1MHz.

VBW=3MHz.

Sweep time = AUTO.

Span: 30MHz (for 20MHz); 60MHz (for 40MHz); 120MHz (for 80MHz).

6.1.3. Test Setup

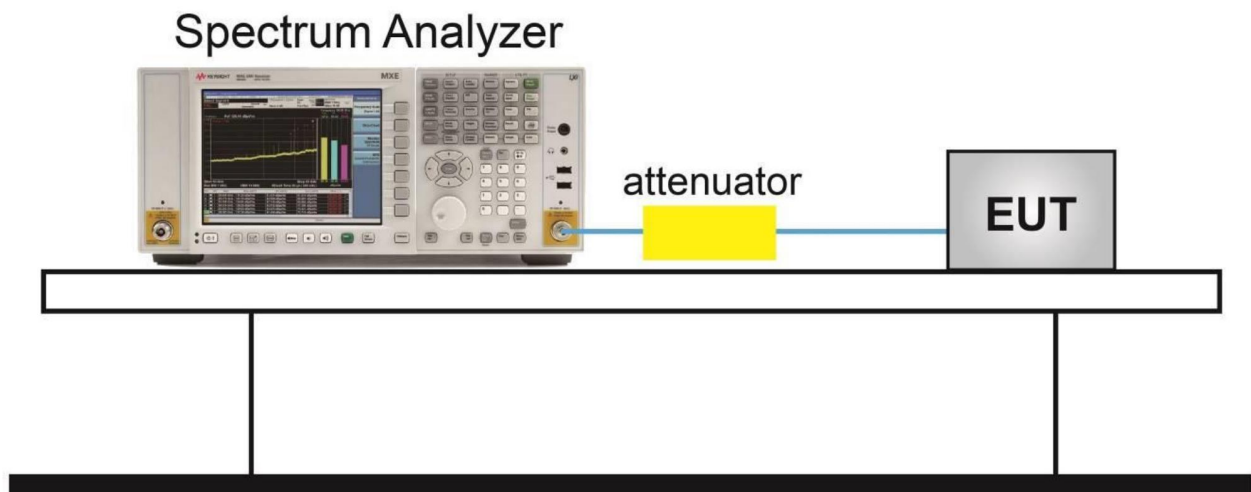



Measurement Results
U-NII-1

Mode	Channel	Conducted (dBm)	E.I.R.P (dBm)	Duty cycle factor (dB)
802.11a	5180	15.41	18.53	0.12
	5200	15.15	18.27	0.12
	5240	14.91	18.03	0.12
802.11n(20MHz)	5180	15.14	18.28	0.14
	5200	14.22	18.25	0.14
	5240	14.75	17.41	0.14
802.11n(40MHz)	5190	14.63	17.89	0.26
	5230	14.46	17.72	0.26
802.11ac	5180	14.87	18.01	0.14
	5200	14.77	17.91	0.14
	5240	14.81	17.95	0.14
802.11ac(40)	5190	14.81	18.07	0.26
	5230	14.7	17.96	0.26

TEST PLOTS:

Output Power-Conducted (802.11a, Ch36)

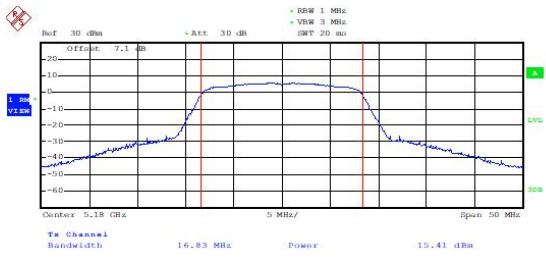

Date: 20.AUG.2021 11:59:07

Output Power-Conducted (802.11a, Ch40)

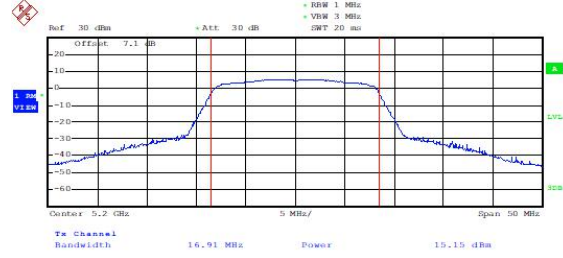

Date: 20.AUG.2021 12:01:10

Output Power-Conducted (802.11a, Ch48)

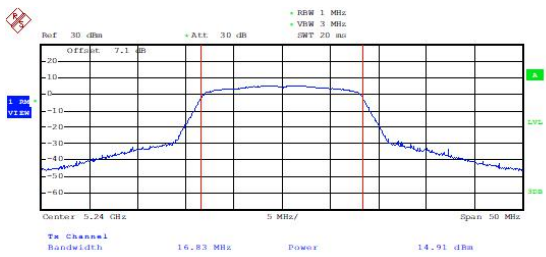

Date: 20.AUG.2021 12:02:16

Output Power-Conducted (802.11n-HT20, Ch36)



Date: 20.AUG.2021 12:03:39

Output Power-Conducted
(802.11n-HT20, Ch40)

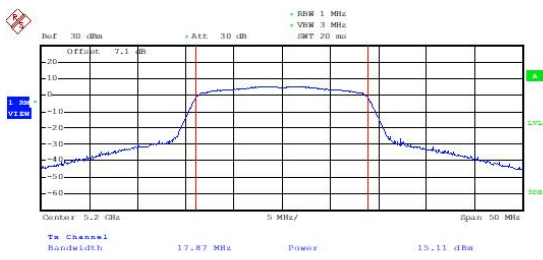

Date: 20.AUG.2021 12:04:45

Output Power-Conducted
(802.11n-HT20, Ch48)

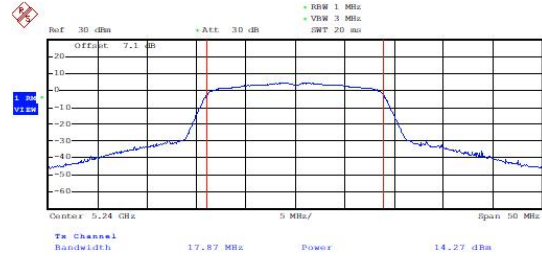

Date: 20.AUG.2021 12:05:59

Output Power-Conducted
(802.11n-HT40, Ch38)

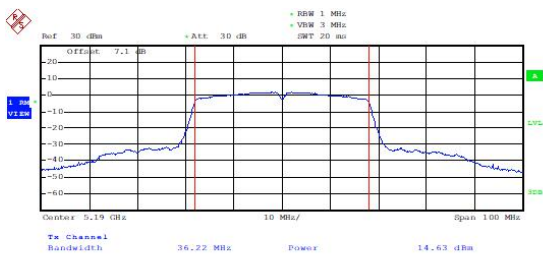

Date: 20.AUG.2021 12:07:35

Output Power-Conducted
(802.11n-HT40, Ch46)

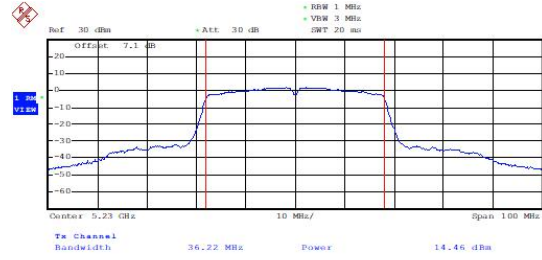

Date: 20.AUG.2021 12:10:34

Output Power-Conducted (802.11ac-VHT20, Ch36)

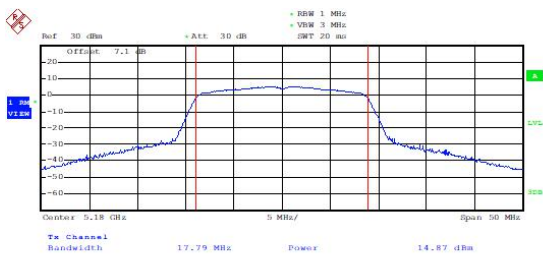

Date: 20.AUG.2021 12:11:56

Output Power-Conducted (802.11ac-VHT20, Ch40)



Date: 20.AUG.2021 12:13:05

Output Power-Conducted (802.11ac-VHT20, Ch48)

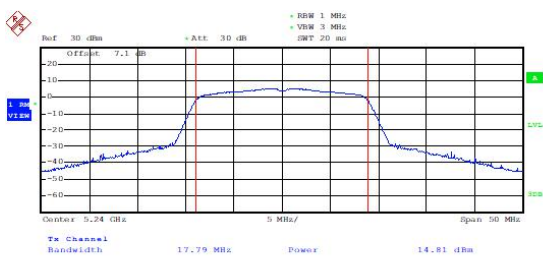

Date: 20.AUG.2021 12:14:22

Output Power-Conducted (802.11ac-VHT40, Ch38)

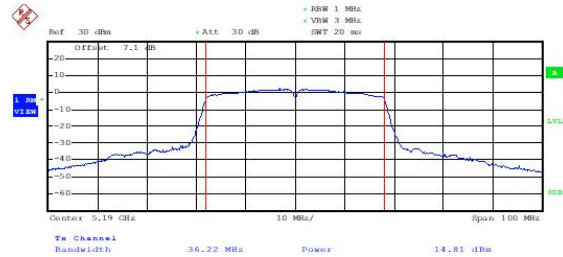

Date: 20.AUG.2021 12:15:31

Output Power-Conducted
(802.11ac-VHT40, Ch46)

/

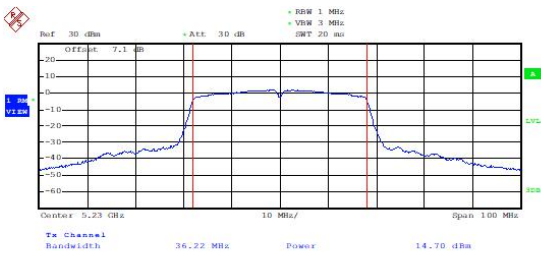

/

Date: 20. AUG. 2021 12:16:30

6.2. Peak Power Spectral Density

6.2.1. Measurement Limit

Standard	Limit (dBm)
FCC 47 CFR Part 15.407(a)(1)(iv)	≤ 11
RSS-247 6.2.1.1	≤ 11

6.2.2. Test Setup

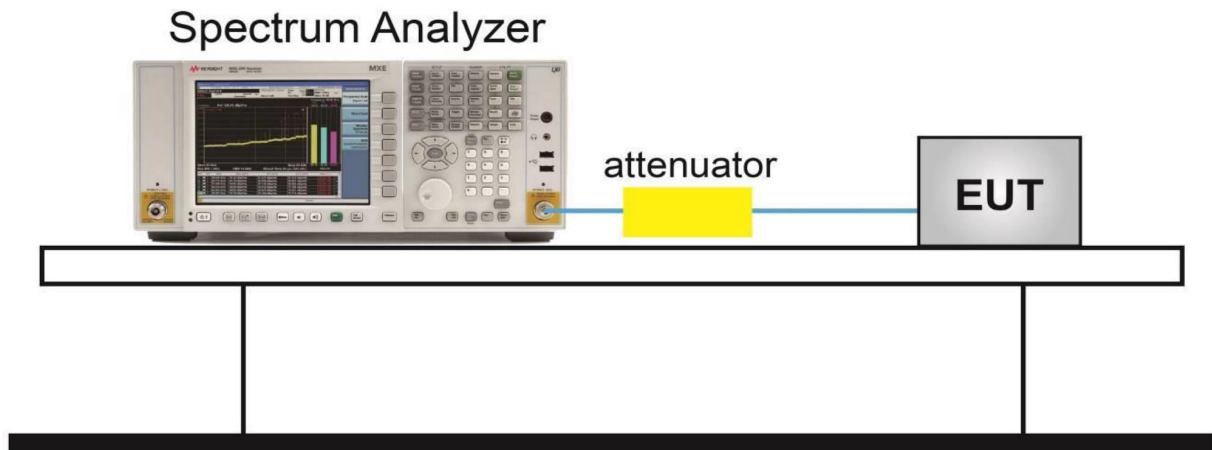

6.2.3. The output power measurement method SA-1 is made according to KDB 789033

Measurement Results

U-NII-1

Mode	Channel	Power Spectral Density (dBm/MHz)	Conclusion
802.11a	5180	5.613	P
	5200	5.997	P
	5240	5.097	P
802.11n HT20	5180	5.443	P
	5200	5.831	P
	5240	5.054	P
802.11n HT40	5190	2.737	P
	5230	2.280	P
802.11ac VHT20	5180	5.282	P
	5200	5.497	P
	5240	4.884	P
802.11ac VHT40	5190	2.470	P
	5230	1.809	P

U-NII-1:

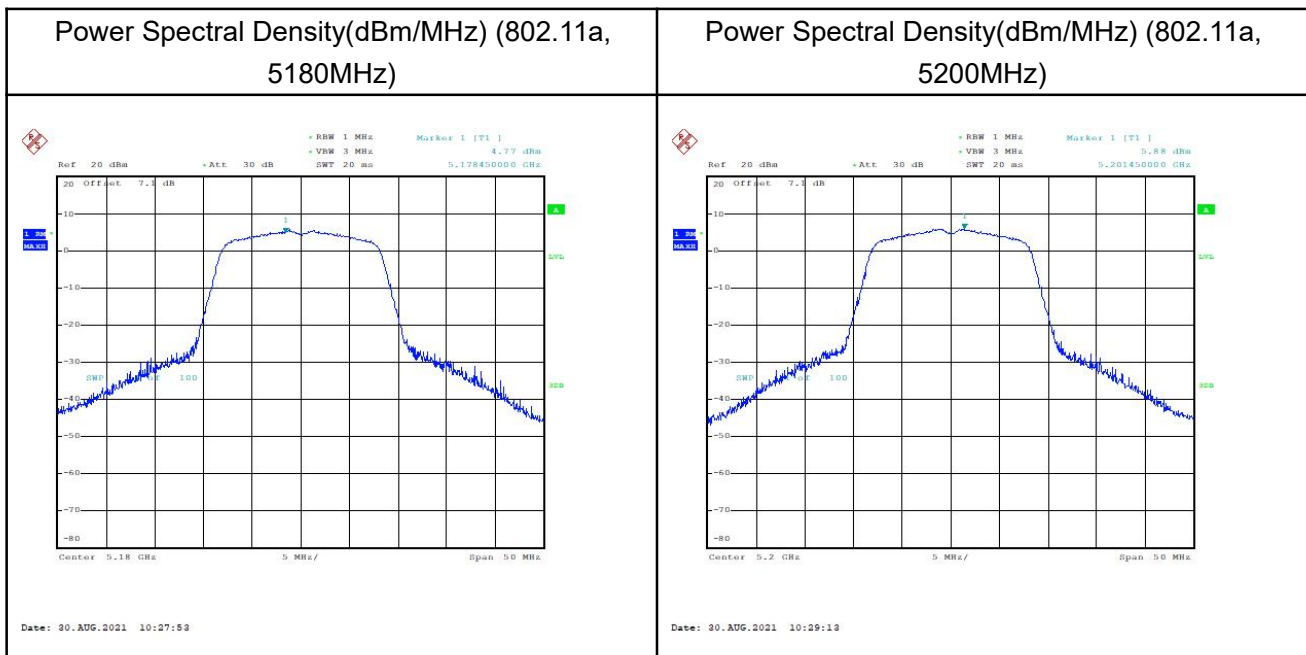

Power Spectral Density(dBm/MHz) (802.11a, 5240MHz)

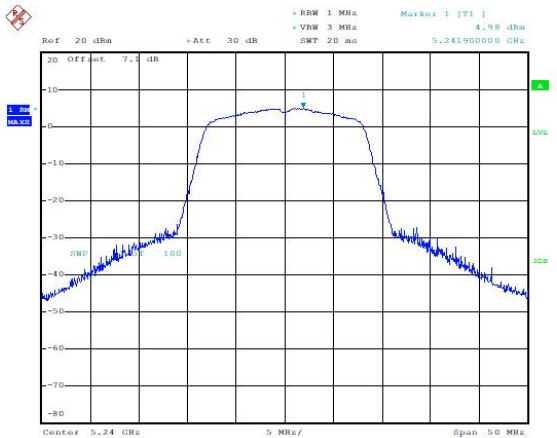

Date: 30.AUG.2021 10:30:09

Power Spectral Density(dBm/MHz) (802.11n-HT20, 5180MHz)

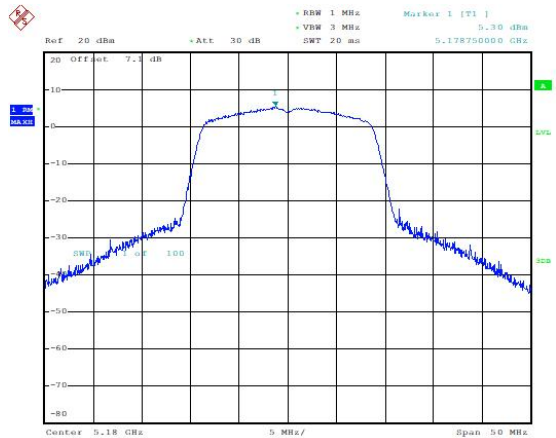

Date: 30.AUG.2021 10:31:32

Power Spectral Density(dBm/MHz) (802.11n-HT20), 5200MHz)

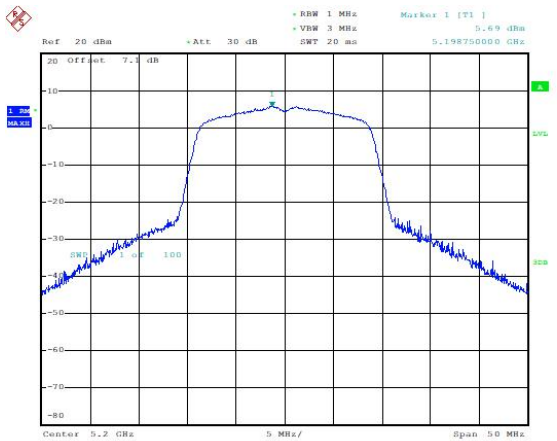

Date: 30.AUG.2021 10:33:18

Power Spectral Density(dBm/MHz) (802.11n-HT20), 5240MHz)

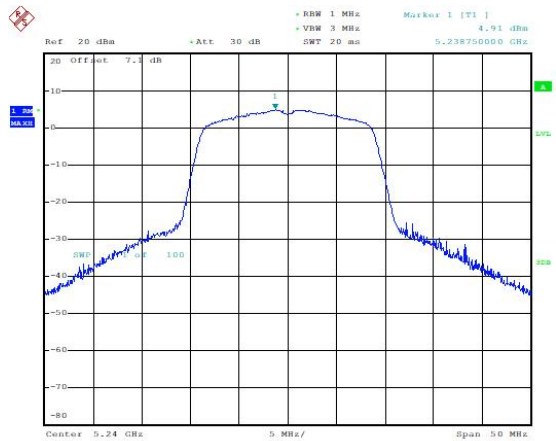

Date: 30.AUG.2021 10:34:25

Power Spectral Density(dBm/MHz)
(802.11n-HT40), 5190MHz)

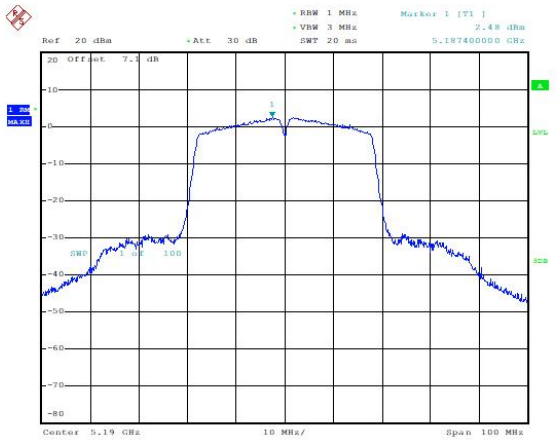

Date: 30.AUG.2021 10:37:10

Power Spectral Density(dBm/MHz)
(802.11n-HT40), 5230MHz)

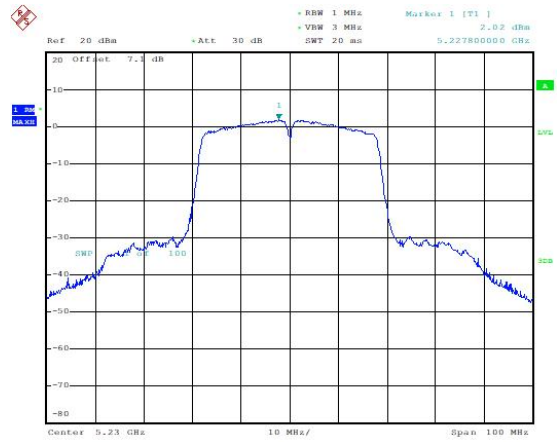

Date: 30.AUG.2021 10:38:17

Power Spectral Density(dBm/MHz)
(802.11ac-VHT20), 5180MHz)

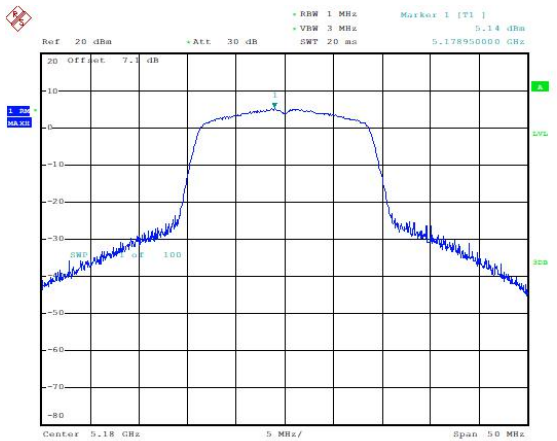

Date: 30.AUG.2021 10:40:02

Power Spectral Density(dBm/MHz)
(802.11ac-VHT20), 5200MHz)

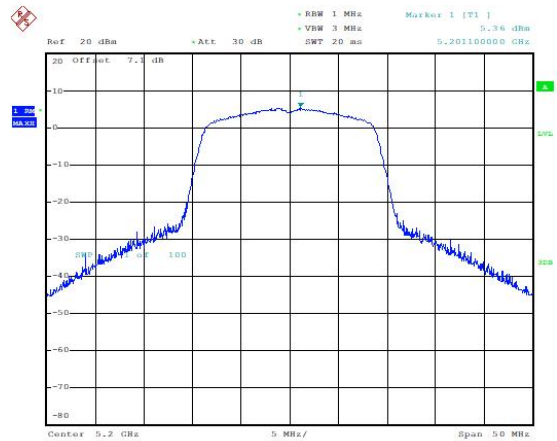

Date: 30.AUG.2021 10:41:54

Power Spectral Density(dBm/MHz)
(802.11ac-VHT20), 5240MHz)

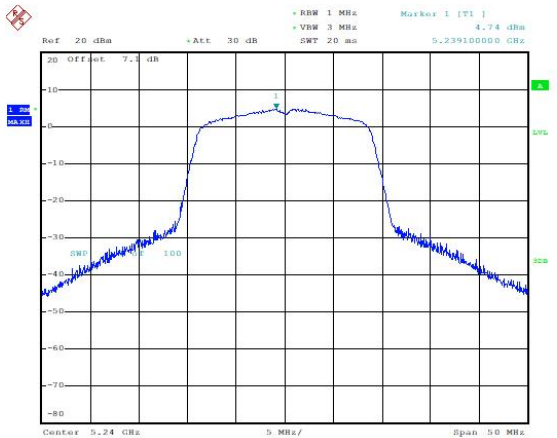

Date: 30.AUG.2021 10:43:49

Power Spectral Density(dBm/MHz)
(802.11ac-VHT40), 5190MHz)

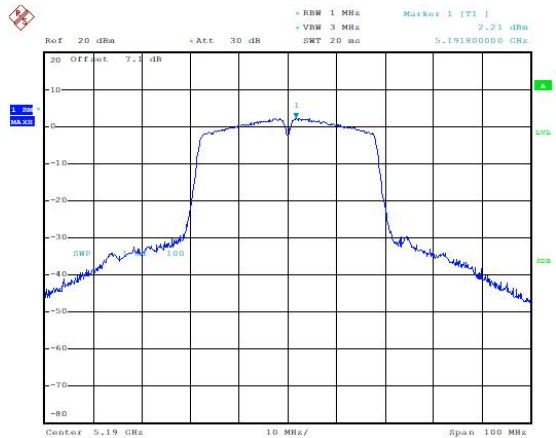

Date: 30.AUG.2021 10:45:57

Power Spectral Density(dBm/MHz)
(802.11ac-VHT40), 5230MHz)

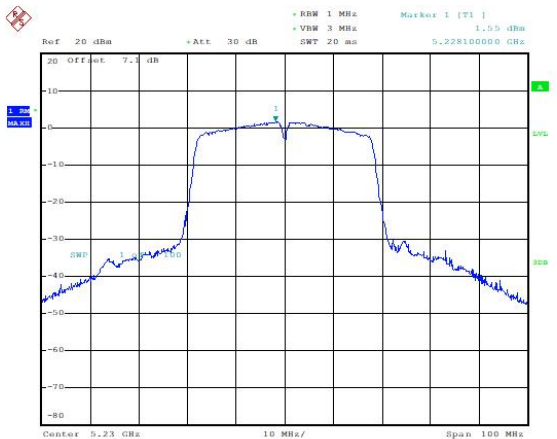

Date: 30.AUG.2021 10:46:56

/

/

6.3. Occupied 26dB Bandwidth(conducted)

6.3.1. Measurement Limit:

Standard	Limit (MHz)
FCC 47 CFR Part 15.407(a)	N/A
RSS-247 6.2	N/A

6.3.2. Test Setup

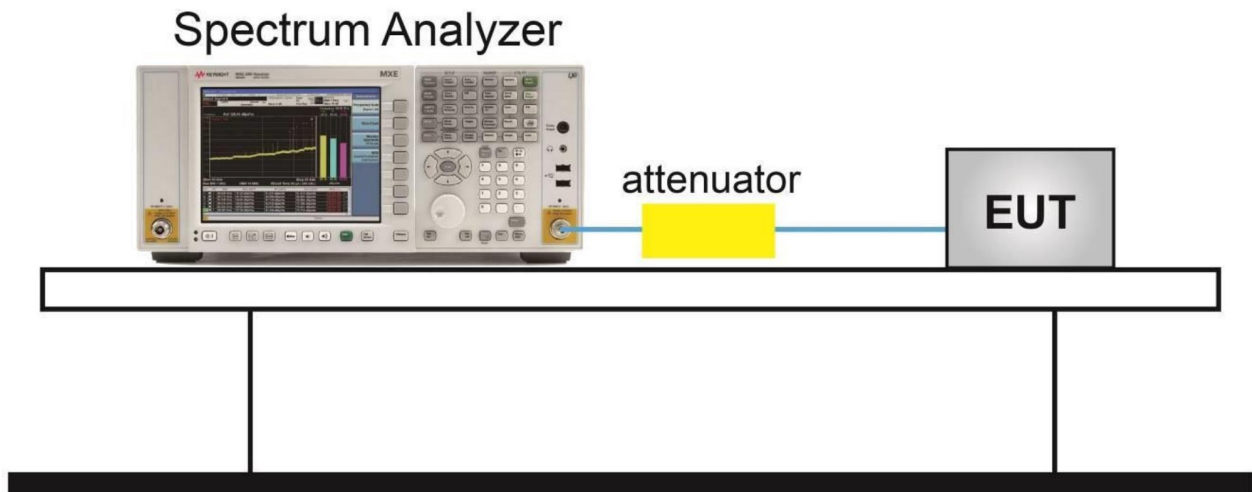

6.3.3. The measurement is made according to KDB 789033

Measurement Result

U-NII-1:

Mode	Channel	Occupied 26dB Bandwidth (MHz)	Conclusion
802.11a	5180 MHz	20.19	P
	5200 MHz	20.35	P
	5240 MHz	20.11	P
802.11n HT20	5180 MHz	20.51	P
	5200 MHz	20.67	P
	5240 MHz	20.59	P
802.11n HT40	5190 MHz	41.03	P
	5230 MHz	41.19	P
802.11ac HT20	5180 MHz	20.59	P
	5200 MHz	20.67	P
	5240MHz	20.67	P
802.11ac HT40	5190 MHz	41.19	P
	5230 MHz	41.19	P

U-NII-1:

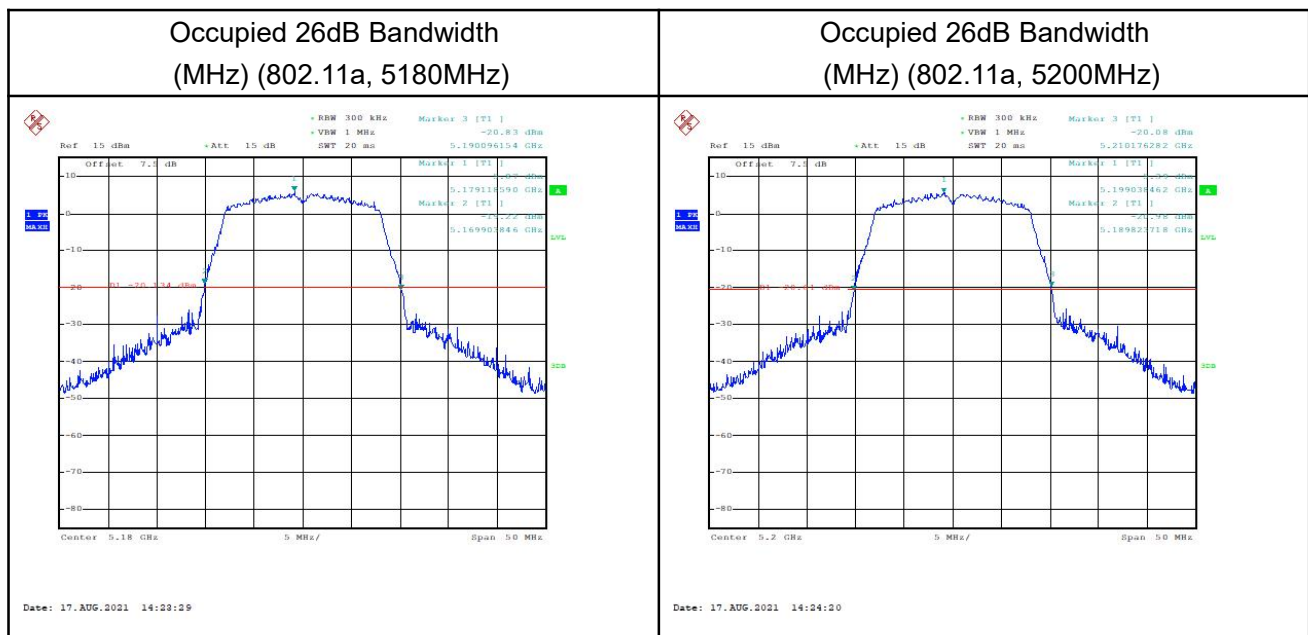

Occupied 26dB Bandwidth
(MHz) (802.11a, 5240MHz)

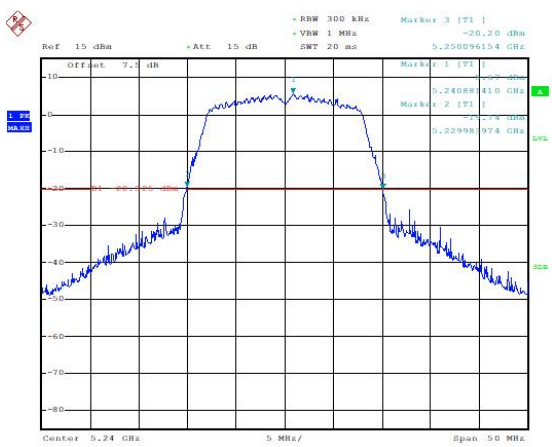

Date: 17.AUG.2021 14:26:25

Occupied 26dB Bandwidth
(MHz) (802.11n-HT20, 5180MHz)

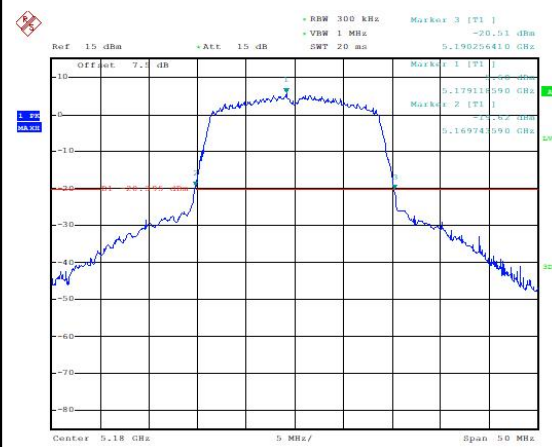

Date: 17.AUG.2021 14:26:43

Occupied 26dB Bandwidth
(MHz) (802.11n-HT20, 5200MHz)

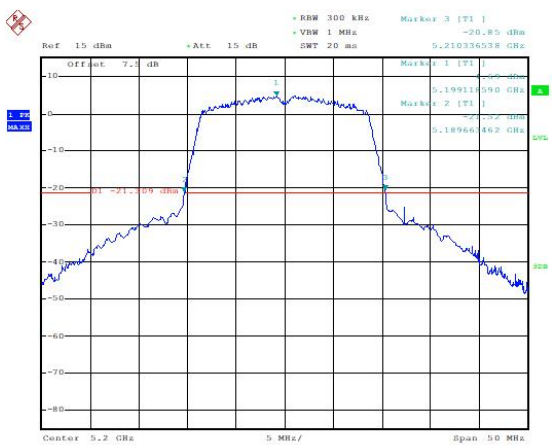

Date: 17.AUG.2021 14:27:47

Occupied 26dB Bandwidth
(MHz) (802.11n-HT20, 5240MHz)

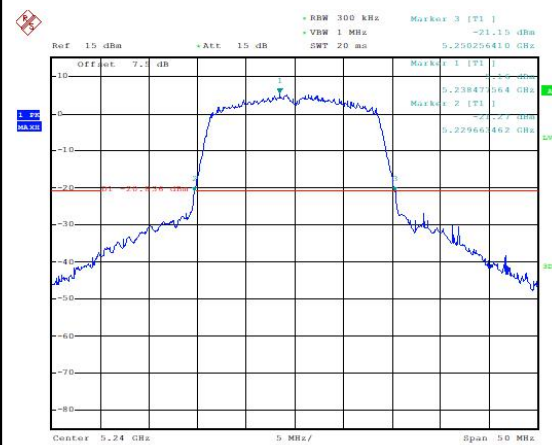

Date: 17.AUG.2021 14:28:33

Occupied 26dB Bandwidth
(MHz) (802.11n-HT40, 5190MHz)

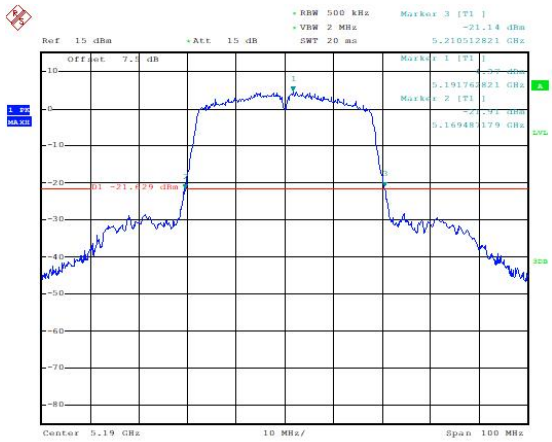

Date: 17.AUG.2021 14:31:18

Occupied 26dB Bandwidth
(MHz) (802.11n-HT40, 5230MHz)

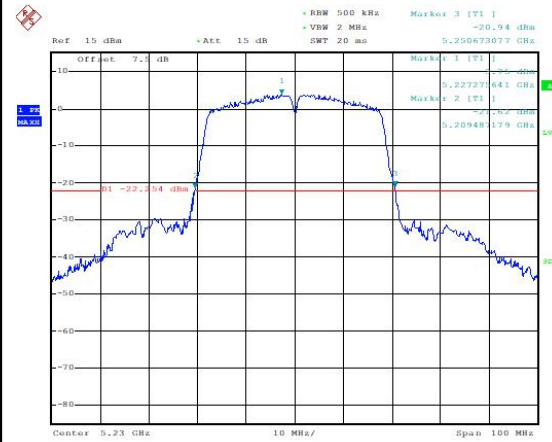

Date: 17.AUG.2021 14:32:25

Occupied 26dB Bandwidth
(MHz) (802.11ac-VHT20, 5180MHz)

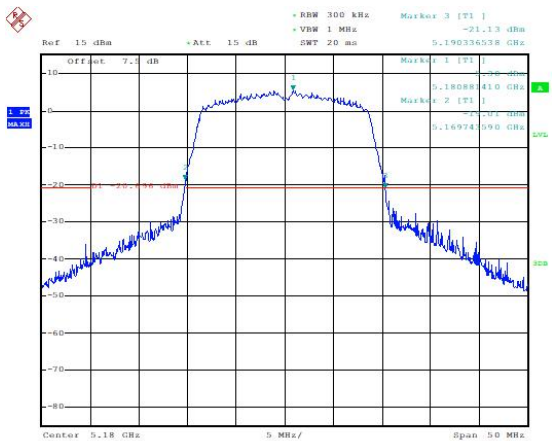

Date: 17.AUG.2021 14:33:45

Occupied 26dB Bandwidth
(MHz) (802.11ac-VHT20, 5200MHz)

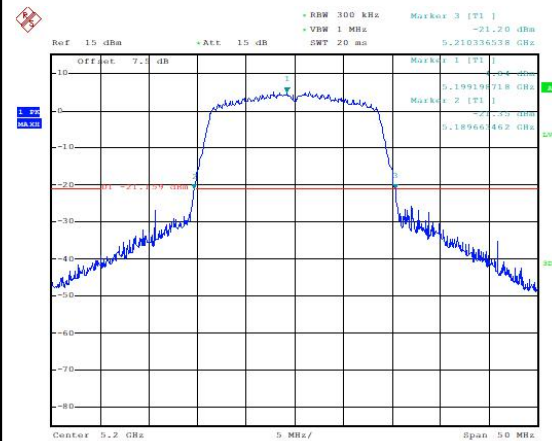

Date: 17.AUG.2021 14:34:36

Occupied 26dB Bandwidth
(MHz) (802.11ac-VHT20, 5240MHz)

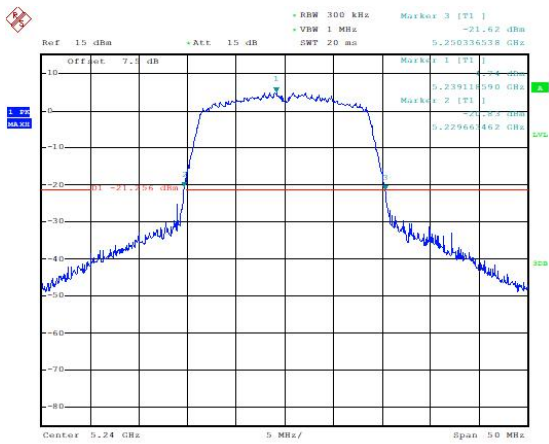

Date: 17.AUG.2021 14:35:44

Occupied 26dB Bandwidth
(MHz) (802.11ac-VHT40, 5190MHz)

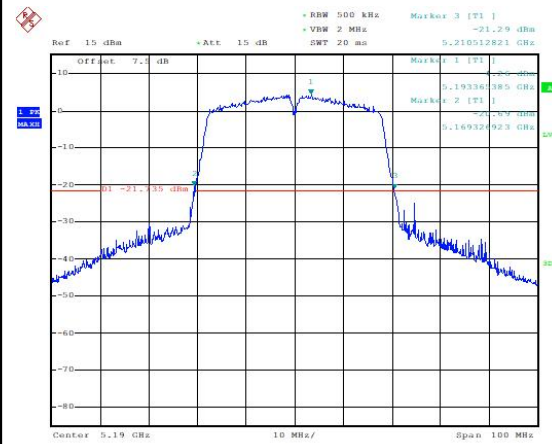

Date: 17.AUG.2021 14:37:31

Occupied 26dB Bandwidth
(MHz) (802.11ac-VHT40, 5230MHz)

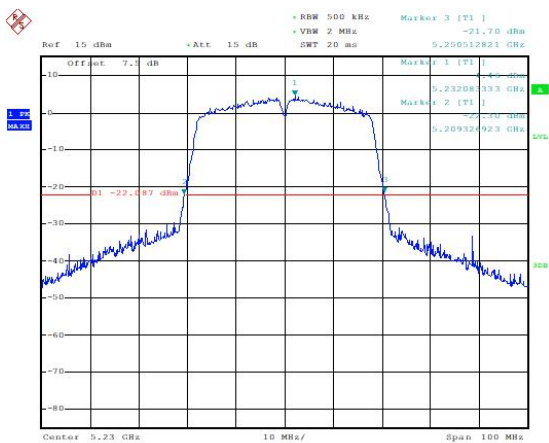

Date: 17.AUG.2021 14:38:22

Occupied 26dB Bandwidth
(MHz) (802.11ac-VHT80, 5210MHz)

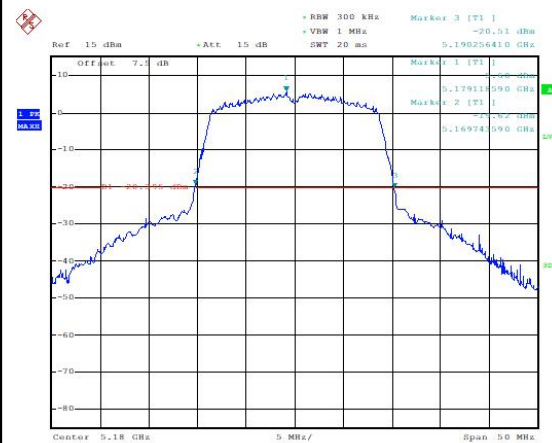

Date: 17.AUG.2021 14:26:49

6.4. 99% Occupied Bandwidth(conducted)

6.4.1. Measurement Limit:

Standard	Limit (MHz)
RSS-Gen 6.7	N/A

6.4.2. Test Setup

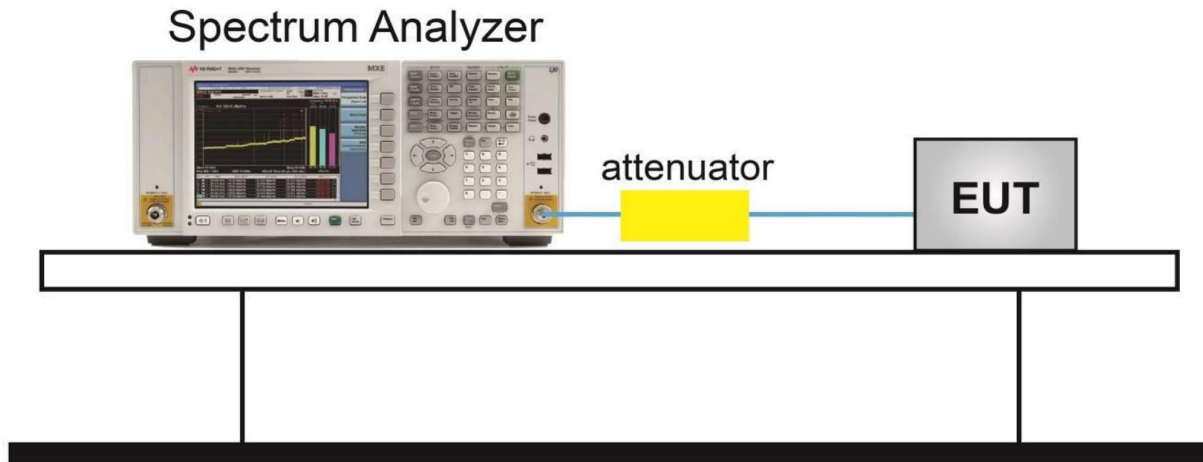

6.4.3. The measurement is made according to KDB 789033

U-NII-1:

Mode	Channel	99% Occupied Bandwidth (MHz)	Conclusion
802.11a	5180 MHz	16.827	P
	5200 MHz	16.907	P
	5240 MHz	16.827	P
802.11n HT20	5180 MHz	17.788	P
	5200 MHz	17.869	P
	5240 MHz	17.869	P
802.11n HT40	5190 MHz	36.218	P
	5230 MHz	36.218	P
802.11ac HT20	5180 MHz	17.788	P
	5200 MHz	17.788	P
	5240MHz	17.788	P
802.11ac HT40	5190 MHz	36.218	P
	5230 MHz	36.218	P

99% Occupied Bandwidth (MHz) (802.11a, 5180MHz)

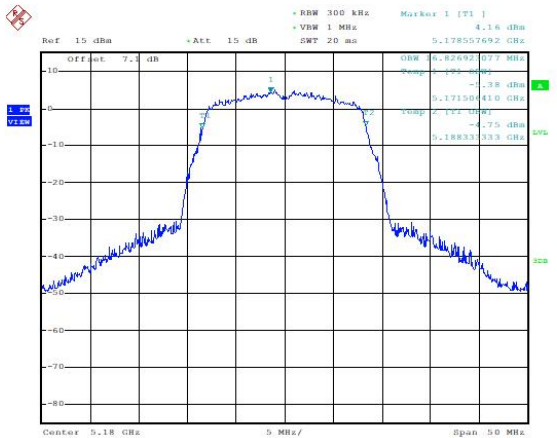

Date: 20.AUG.2021 11:31:08

99% Occupied Bandwidth (MHz) (802.11a, 5200MHz)

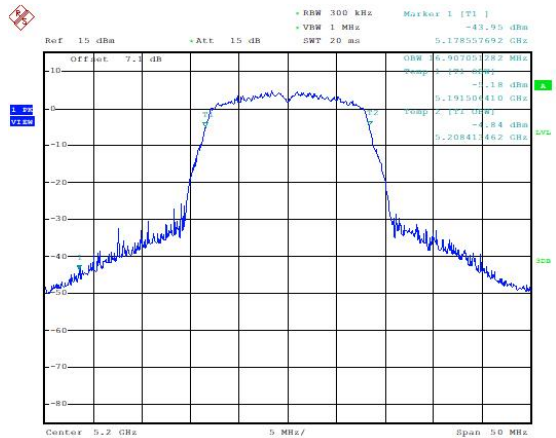

Date: 20.AUG.2021 11:33:02

99% Occupied Bandwidth (MHz) (802.11a, 5240MHz)

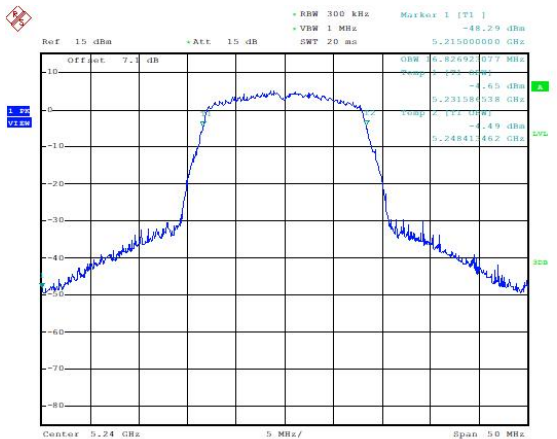

Date: 20.AUG.2021 11:34:01

99% Occupied Bandwidth (MHz) (802.11n-HT20, 5180MHz)

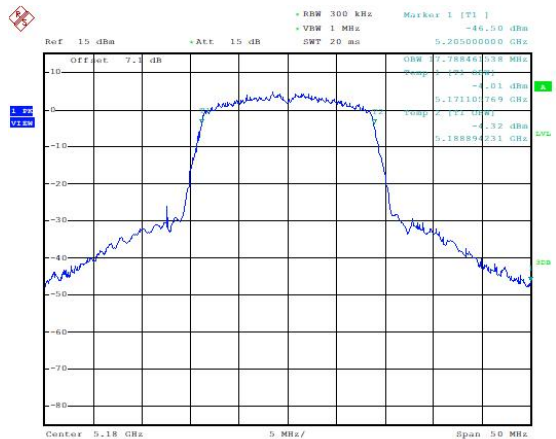

Date: 20.AUG.2021 11:35:45

99% Occupied Bandwidth (MHz) (802.11n-HT20),
5200MHz)



99% Occupied Bandwidth (MHz)
(802.11n-HT20), 5240MHz)



99% Occupied Bandwidth (MHz) (802.11n-HT40),
5190MHz)

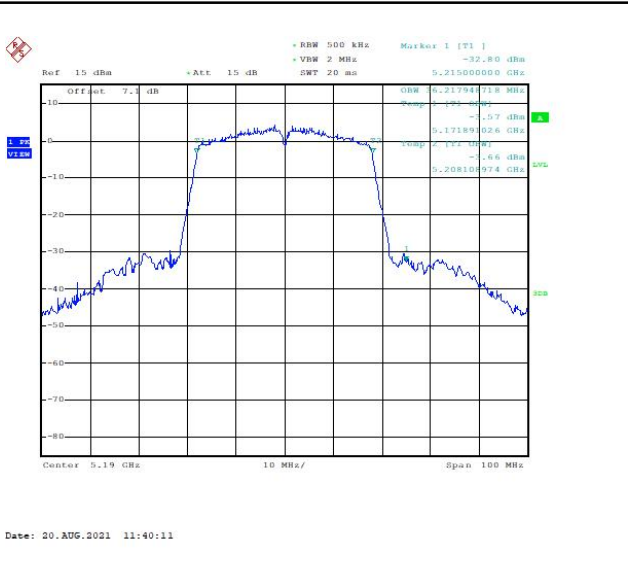

99% Occupied Bandwidth (MHz) (802.11n-HT40),
5230MHz)

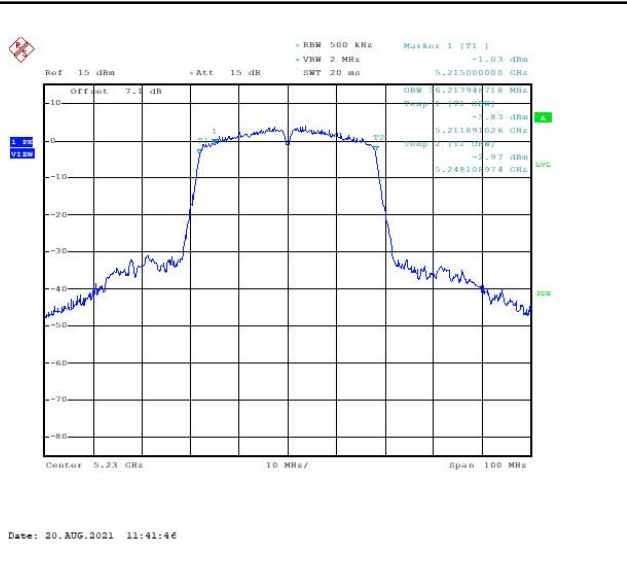

99% Occupied Bandwidth (MHz)
(802.11ac-VHT20), 5180MHz)

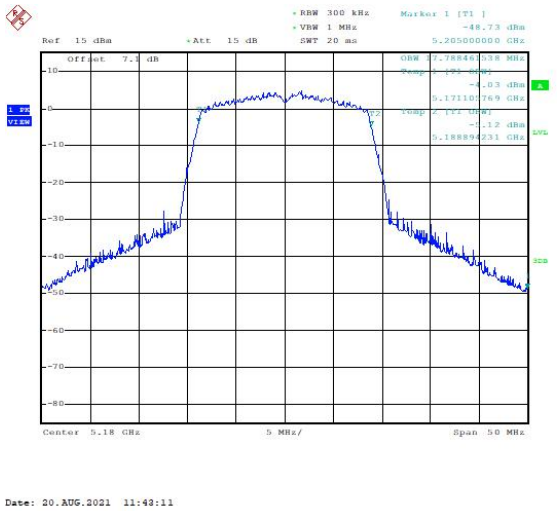

99% Occupied Bandwidth (MHz)
(802.11ac-VHT20), 5200MHz)

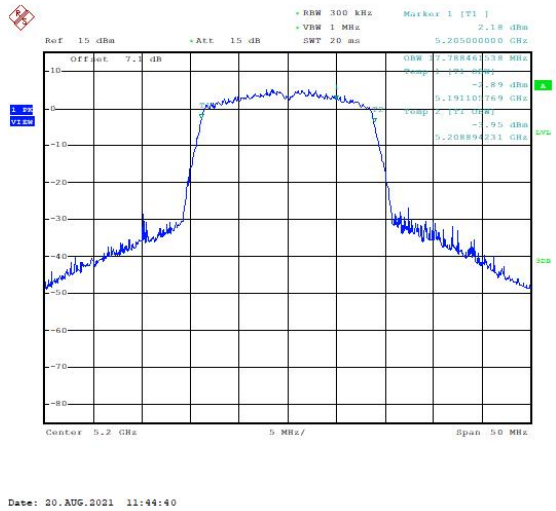

99% Occupied Bandwidth (MHz)
(802.11ac-VHT20), 5240MHz)

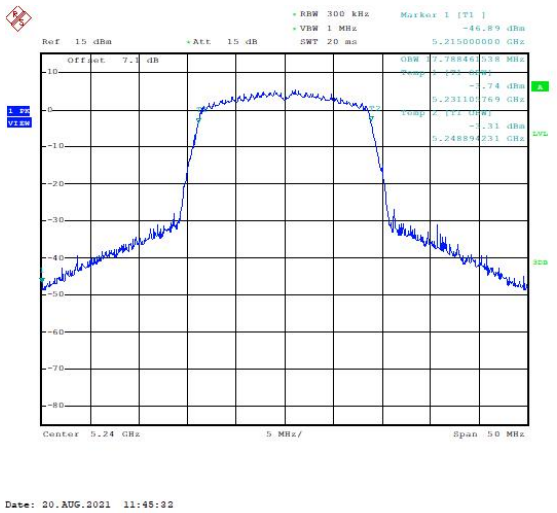

99% Occupied Bandwidth (MHz)
(802.11ac-VHT40), 5190MHz)

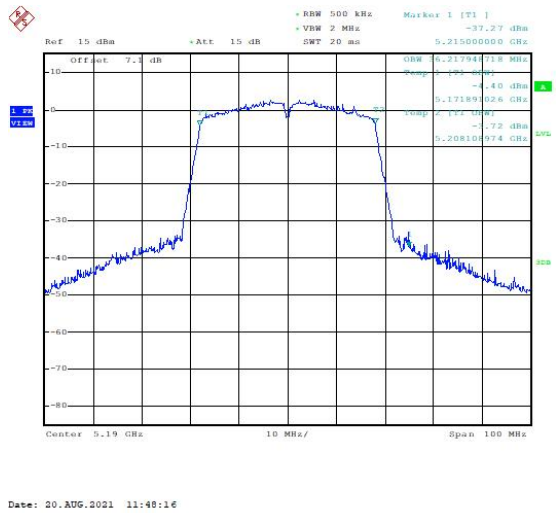

99% Occupied Bandwidth (MHz)
(802.11ac-VHT40), 5230MHz)

/

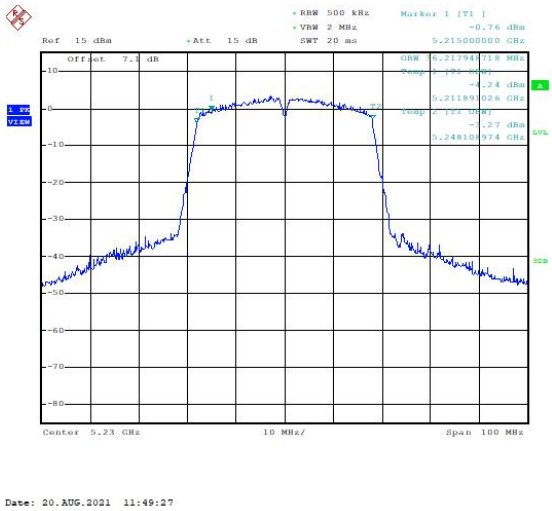

/

6.5. Band Edges Compliance

6.5.1. Band Edges - conducted

Measurement Limit:

Standard	Limit (dBm/MHz)
FCC 47 CFR Part 15.407(b)(1)	< -27
RSS-247 6.2.1.2	< -27

Note:The test doesn't add the antenna gain to the test plots.

6.5.2. The measurement is made according to KDB 789033

6.5.3. Test Setup

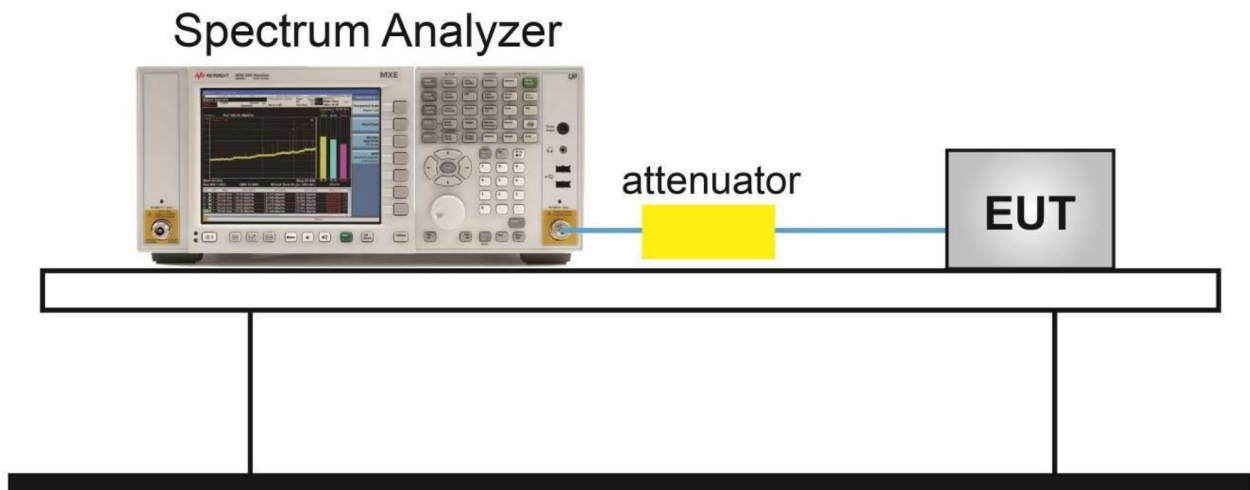



Measurement Result

U-NII-1:

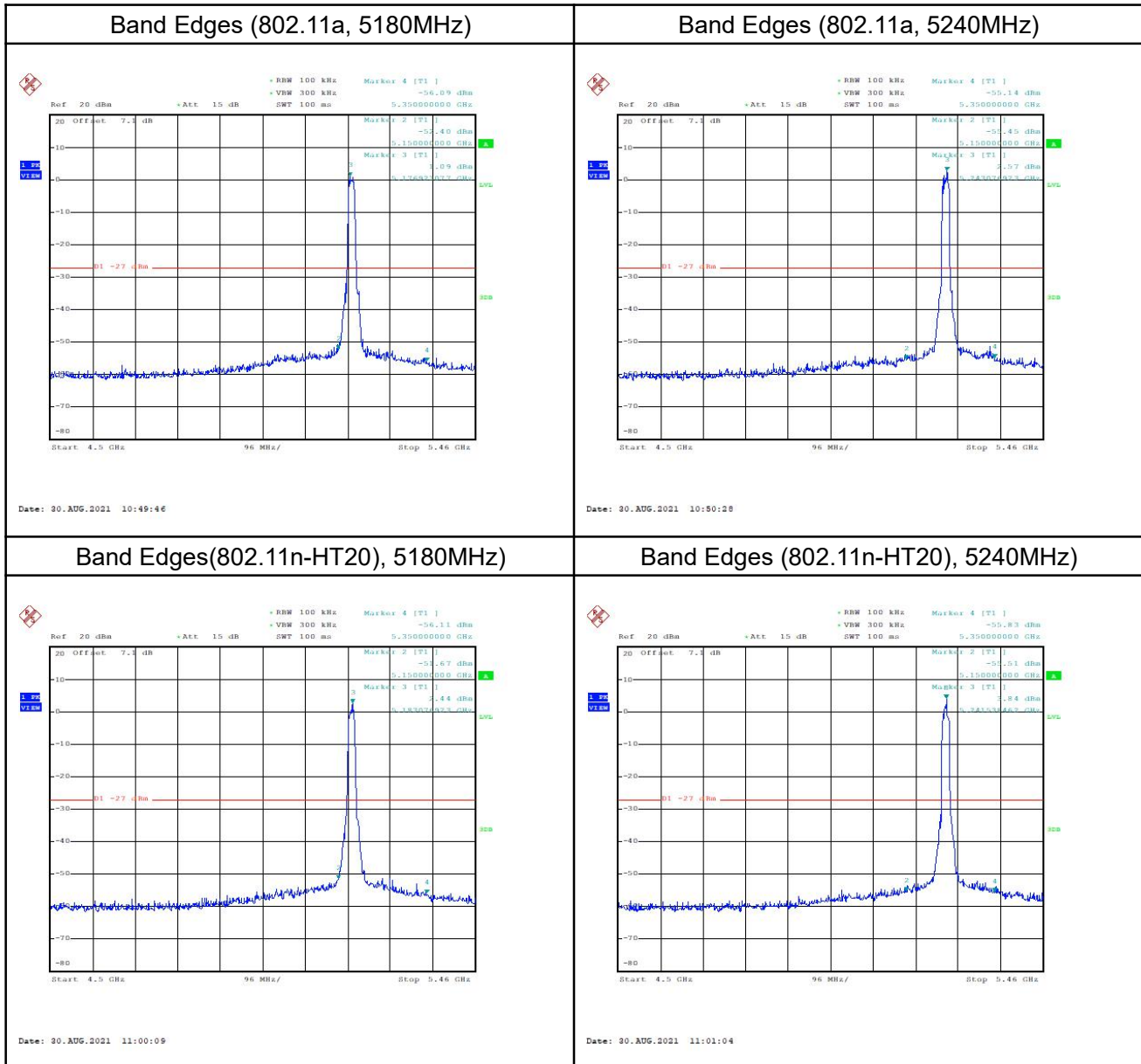

Band Edges(802.11n-HT40), 5190MHz

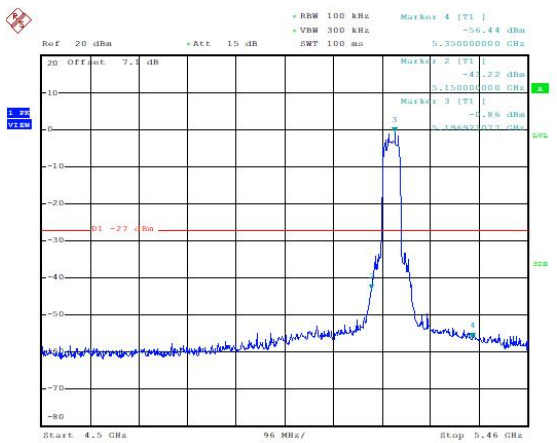

Date: 30.AUG.2021 10:52:02

Band Edges (802.11n-HT40), 5230MHz

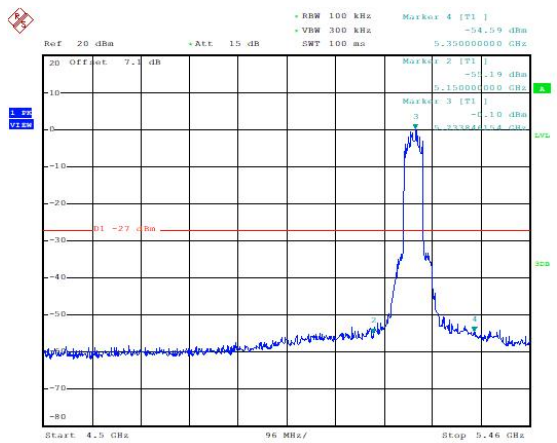

Date: 30.AUG.2021 10:53:24

Band Edges (802.11ac-VHT20), 5180MHz

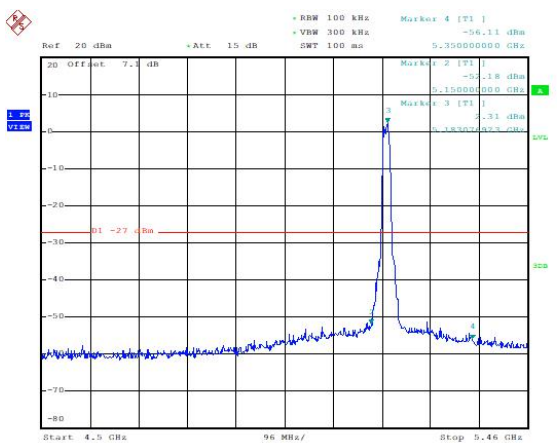

Date: 30.AUG.2021 10:54:01

Band Edges (802.11ac-VHT20), 5240MHz

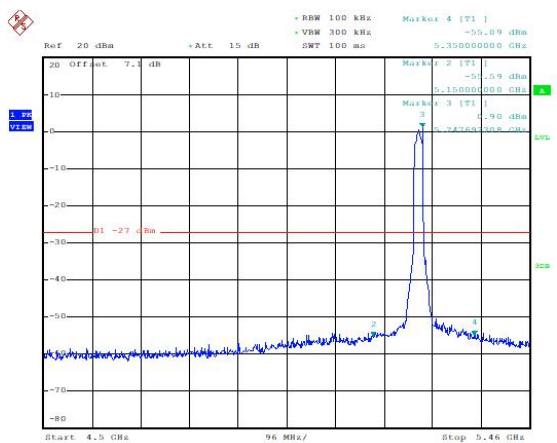

Date: 30.AUG.2021 10:56:39

Band Edges (802.11ac-VHT40), 5190MHz

Band Edges (802.11ac-VHT40), 5230MHz

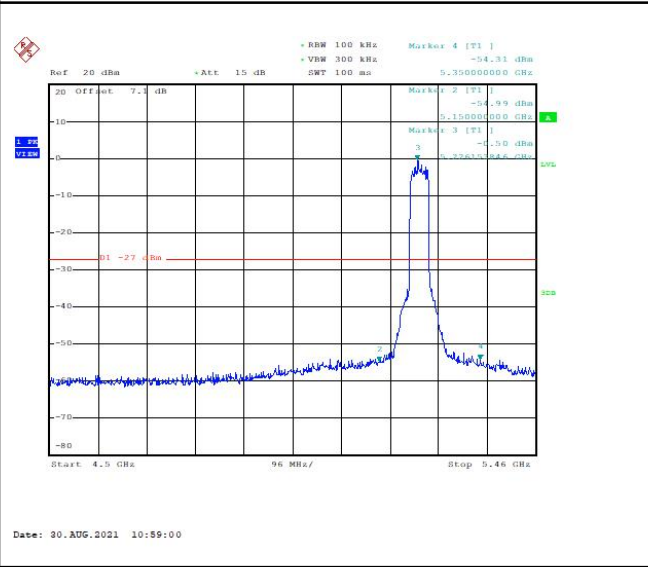
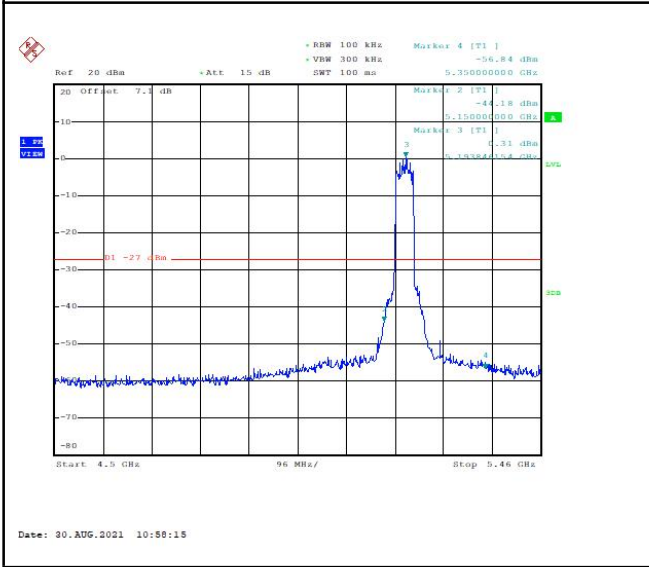

6.5.2. Band Edges - Radiated

6.5.2.1 Measurement Limit:

Standard	Limit (dB μ V/m)	
	FCC 47 CFR Part 15.209 & 15.407(b)(9),(10)	Peak
	Average	54
RSS-Gen 8.9,8.10	Peak	74
RSS-247 6.2.1.2	Average	54

6.5.2.2 The measurement is made according to KDB 789033.

Measurement Result U-NII-1:

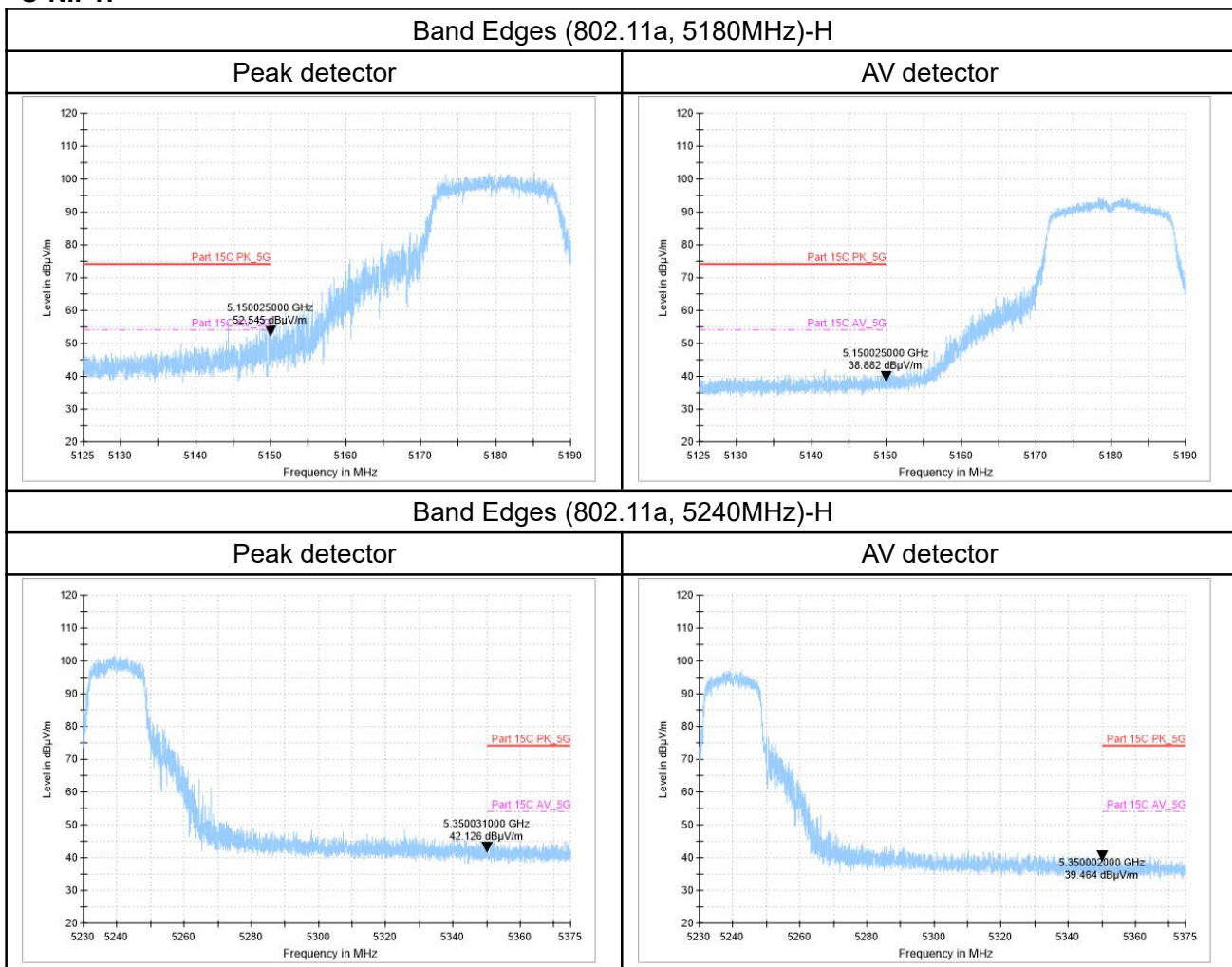

Band Edges (802.11n-HT20, 5180MHz)-V

Peak detector

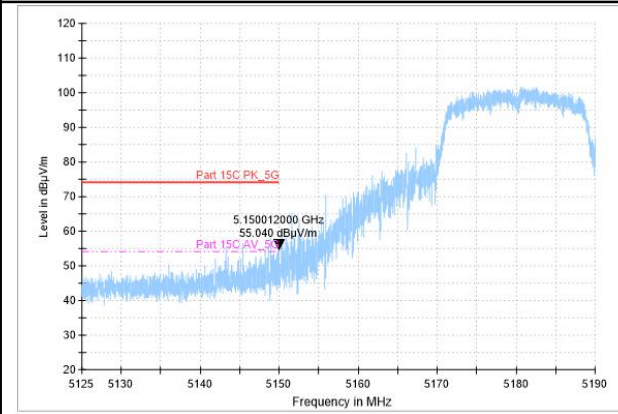

AV detector

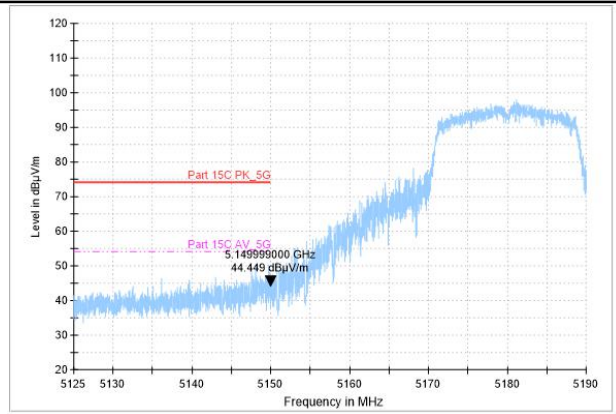

Band Edges (802.11n-HT20, 5240MHz)-H

Peak detector

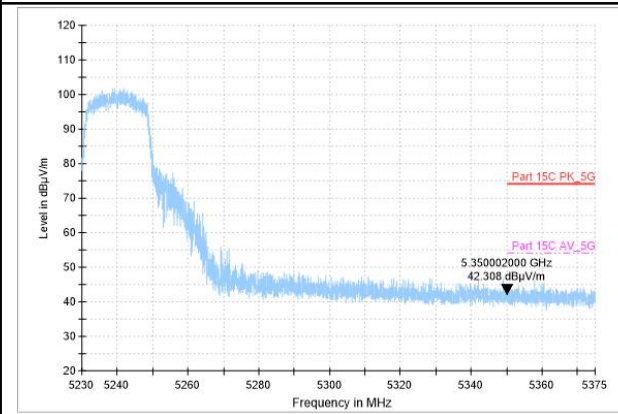

AV detector

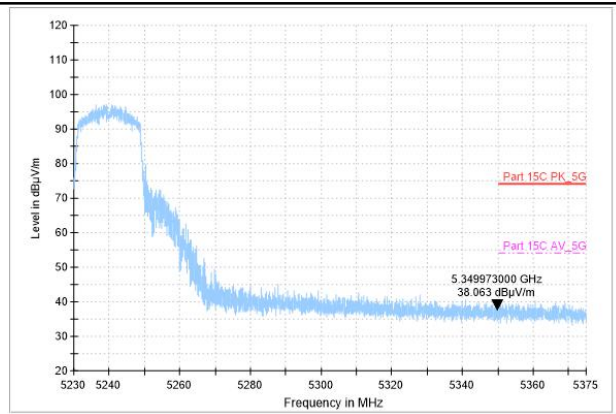

Band Edges (802.11n-HT40, 5190MHz)-V

Peak detector

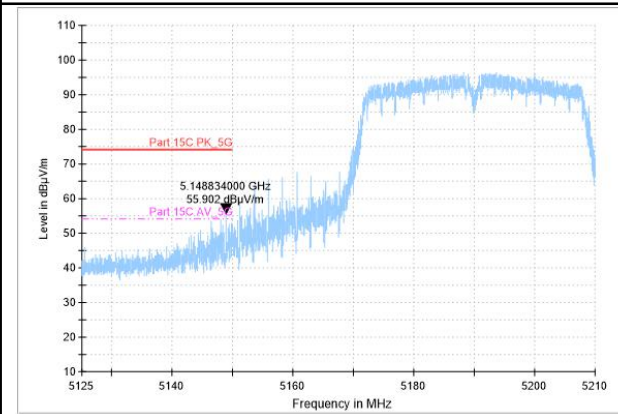

AV detector

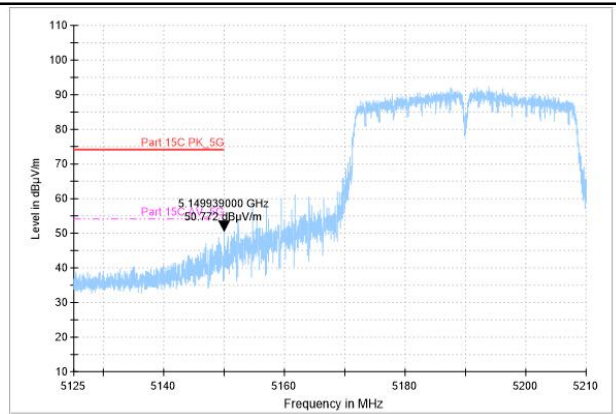

Band Edges (802.11n-HT40, 5230MHz)-V

Peak detector

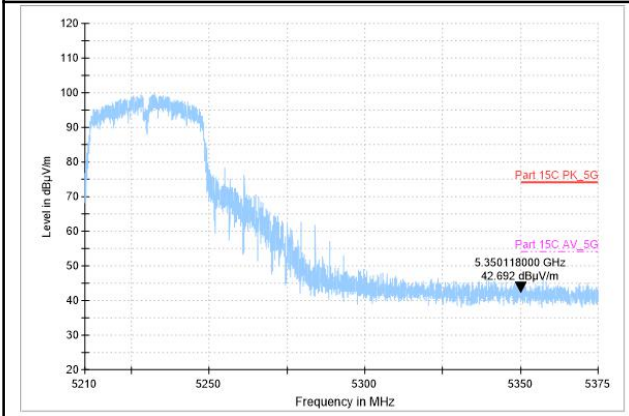

AV detector

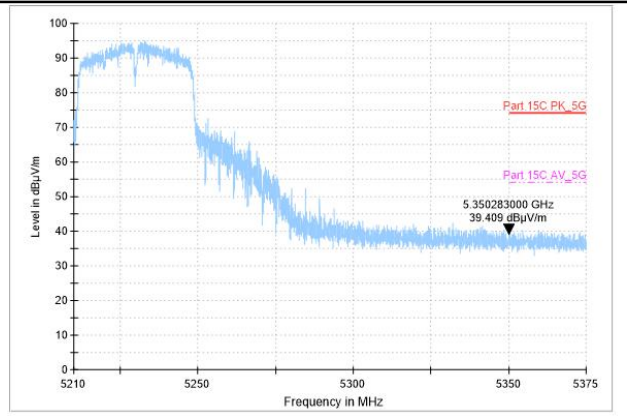

Band Edges (802.11ac-HT20, 5180MHz)-H

Peak detector

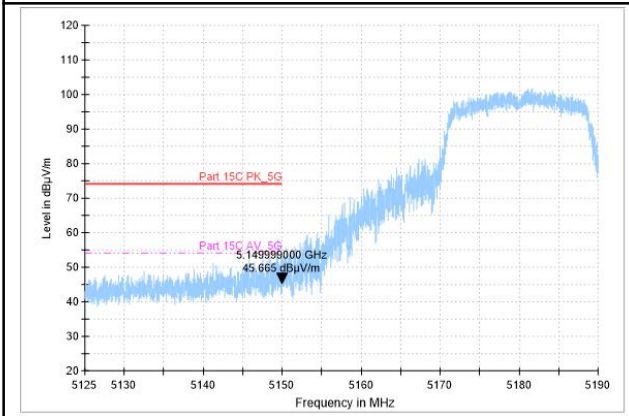

AV detector

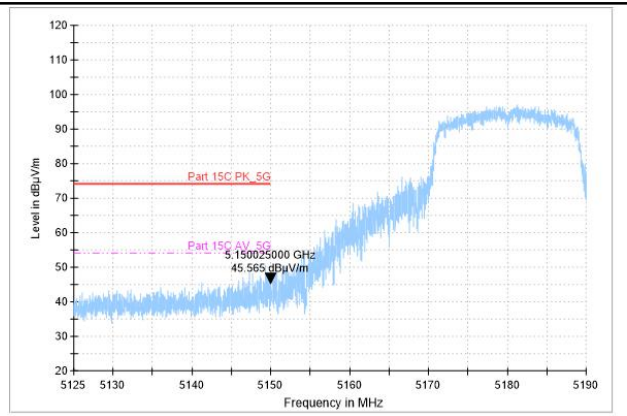

Band Edges (802.11ac-HT20, 5240MHz)-H

Peak detector

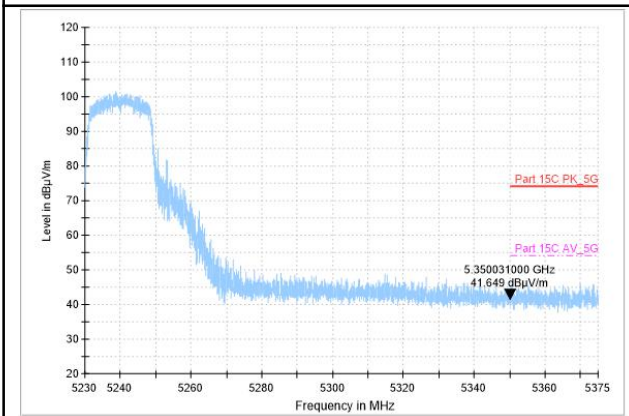

AV detector

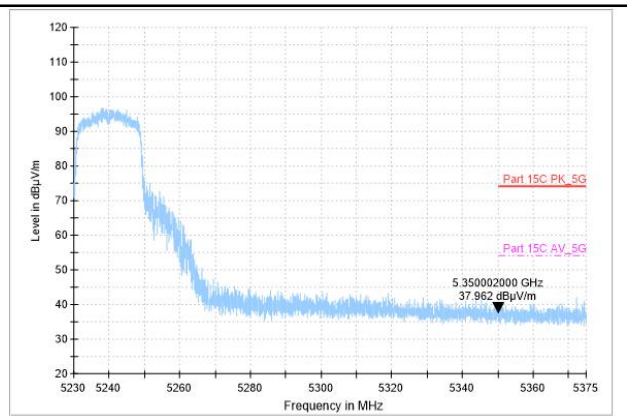

Band Edges (802.11ac-HT40, 5190MHz)-H

Peak detector

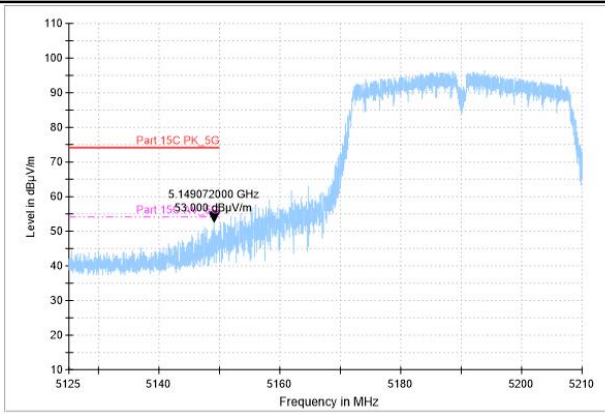

AV detector

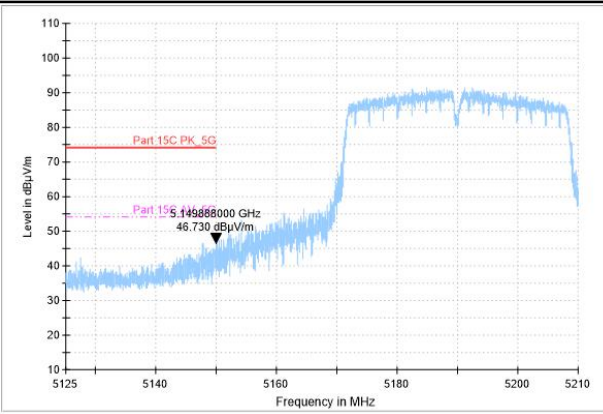

Band Edges (802.11ac-HT40, 5230MHz)-V

Peak detector

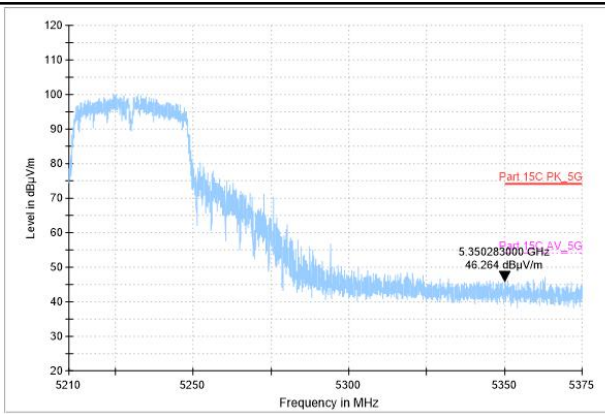

AV detector

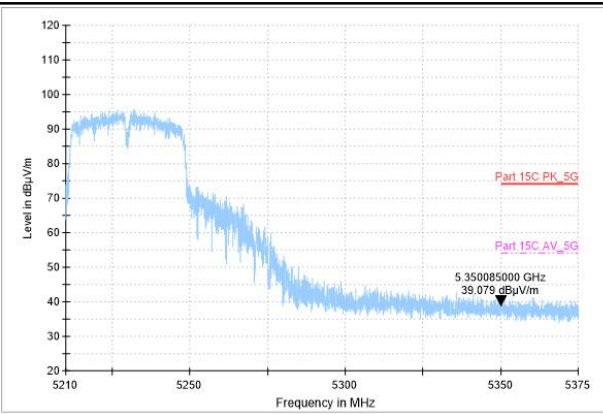

6.6. Transmitter Spurious Emission

6.6.1. Measurement Limit

Standard	Limit (dB μ V/m)	
	FCC 47 CFR Part 15.209 & 15.407(b)(9),(10)	Peak
Average		54
RSS-Gen 8.9,8.10 RSS-247 6.2.1.2	Peak	74
	Average	54

6.6.2. The measurement is made according to KDB 789033

Set the spectrum analyzer in the following:

Below 1GHz (detector: Peak and Quasi-Peak)

RBW=100kHz / VBW=300kHz / Sweep=AUTO

Above 1GHz (detector: Peak):

(a) PEAK: RBW=1MHz / VBW=3MHz / Sweep=AUTO

(b) AVERAGE: RBW=1MHz / VBW=3MHz / Sweep= AUTO

Limit in restricted band:

Frequency of emission (MHz)	Field strength(dB μ V/m)	Measurement distance(m)
0.009-0.490	129-94	3
0.490-1.705	74-63	3
1.705-30	70	3
30-88	40.0	3
88-216	43.5	3
216-960	46.0	3
Above 960	54.0	3

Note: for frequency range below 960MHz, the limit in 15.209 is defined in 10m test distance. The limit used above is calculated from 10m to 3m

6.6.3. Test Setup

Below 1GHz Test Setup

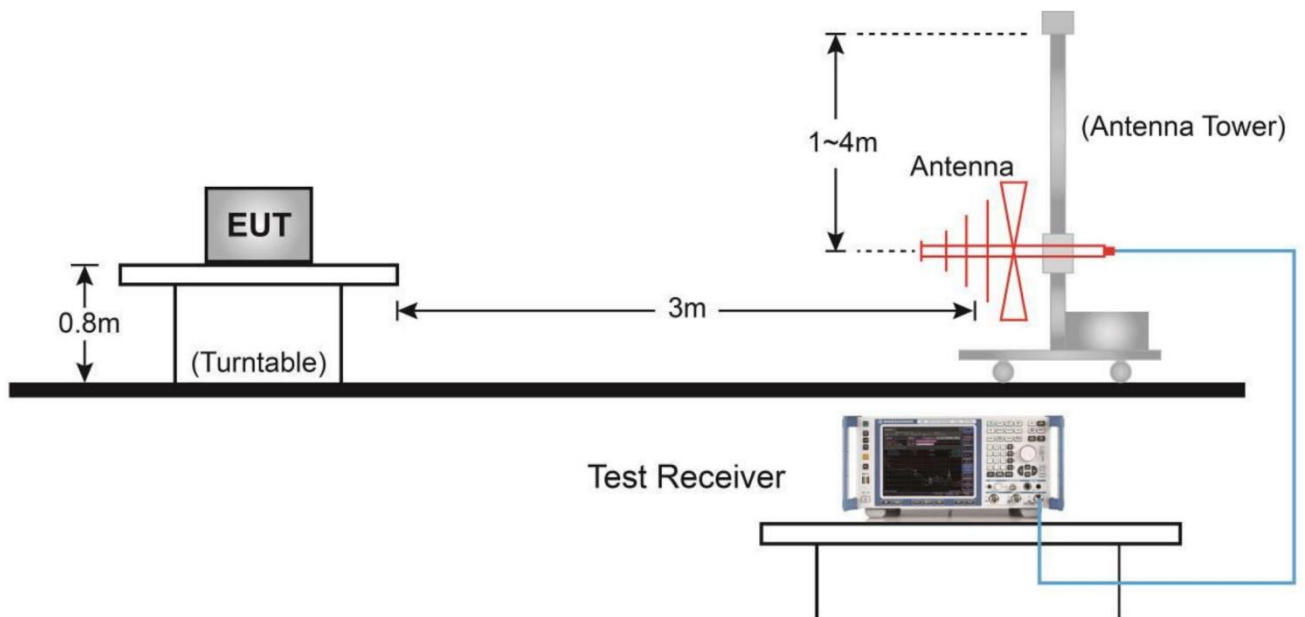

Above 1GHz Test Setup

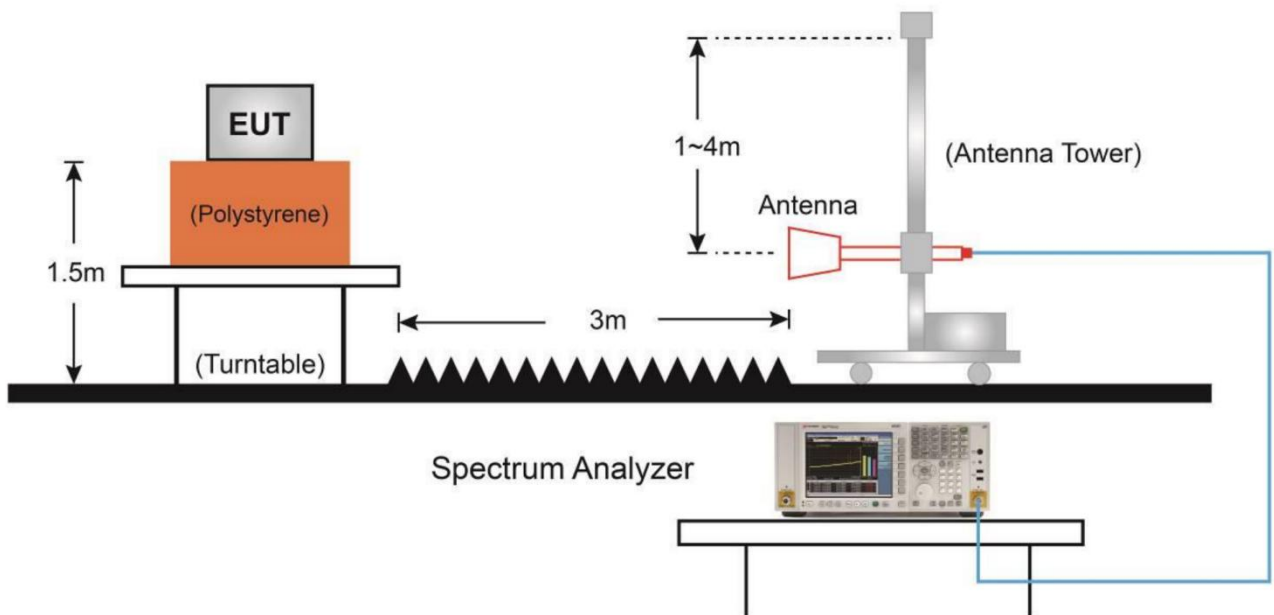

Test procedures

The measurement was applied in a semi - anechoic chamber. While testing for spurious emission higher than 1GHz, if applied, the pre - amplifier would be equipped just at the output terminal of the antenna.

Tabletop devices shall be placed on a nonconducting platform with nominal top surface dimensions 1 m by 1.5 m. For emissions testing at or below 1 GHz, the table height shall be 80 cm above the reference ground plane. For emission measurements above 1 GHz, the table height shall be 1.5 m.

The turntable rotated 360 degrees to determine the position of the maximum emission level.

The EUT was set 3 meters away from the receiving antenna which was mounted on an antenna mast. The antenna moved up and down between from 1meter to 4 meters to find out the maximum emission level.

The EUT was tested according to KDB 789033 D02: Section G.

The radiated emission was measured using the Spectrum Analyzer with the resolutions bandwidth set as:

RBW = 300 Hz, VBW = 1 kHz (9 kHz~150 kHz);

RBW = 10 kHz, VBW = 30 kHz (150 kHz~30MHz);

RBW = 100 kHz, VBW = 300 kHz (30MHz~1GHz for PK)

RBW = 1MHz, VBW = 3MHz (>1GHz for PK);

Remark:

1. Factor= Antenna Factor + Cable Loss (- Amplifier, is employed)
2. Measured level= Original Receiver Reading + Factor
3. Margin = Limit – Measured level
4. If the PK measured level is lower than AV limit, the AV test can be elided

Modulation type and data rate tested (Only worst case result is given below):

U-NII-1:

Mode	Data rate	Channel
802.11a	6Mbps	36(5180MHz)
802.11n-HT20	MCS0	48(5240MHz)
802.11n-HT40	MCS0	38(5190MHz)
802.11ac-HT20	MCS0	36(5180MHz)
802.11ac-HT40	MCS0	38(5190MHz)

Measurement Results

U-NII-1

<p style="text-align: center;">Radiated Spurious Emission (802.11a, ch36, 30MHz-1GHz)</p>	<p style="text-align: center;">Radiated Spurious Emission (802.11a, ch36, 1GHz-8GHz)</p>
<p style="text-align: center;">Radiated Spurious Emission (802.11a, ch36, 8GHz-18GHz)</p>	<p style="text-align: center;">Radiated Spurious Emission (802.11a, ch36, 18GHz-26.5GHz)</p>
<p style="text-align: center;">Radiated Spurious Emission (802.11a, ch36, 26.5 GHz-40 GHz)</p>	<p style="text-align: center;">/</p>
	<p style="text-align: center;">/</p>

Radiated Spurious Emission
(802.11n-HT20, ch48, 30MHz-1GHz)

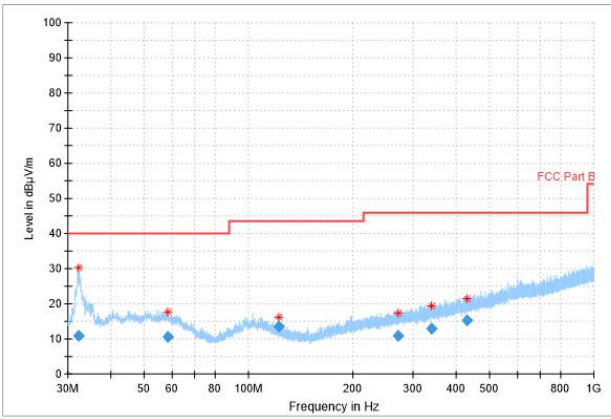

Radiated Spurious Emission
(802.11n-HT20, ch48, 1GHz-8GHz)

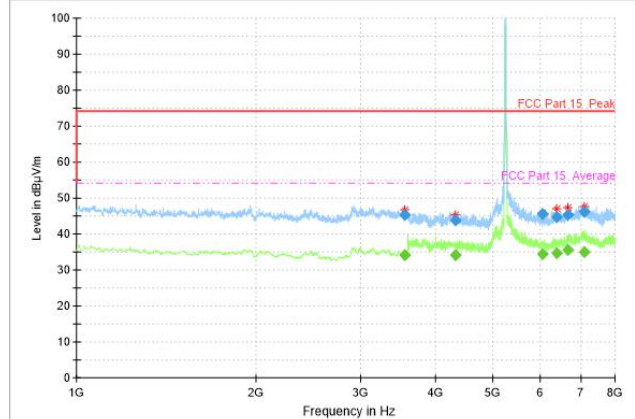

Radiated Spurious Emission
(802.11n-HT20, ch48, 8GHz-18GHz)

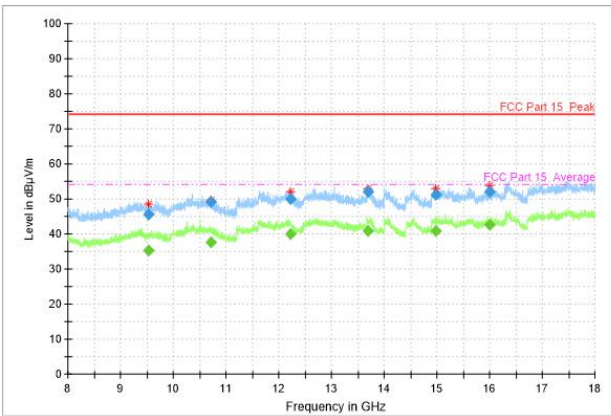

Radiated Spurious Emission
(802.11n-HT20, ch48, 18GHz-26.5GHz)

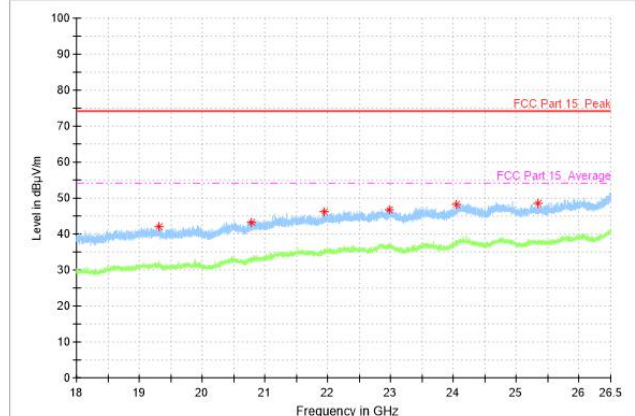

Radiated Spurious Emission
(802.11n-HT20, ch48, 26.5 GHz-40 GHz)

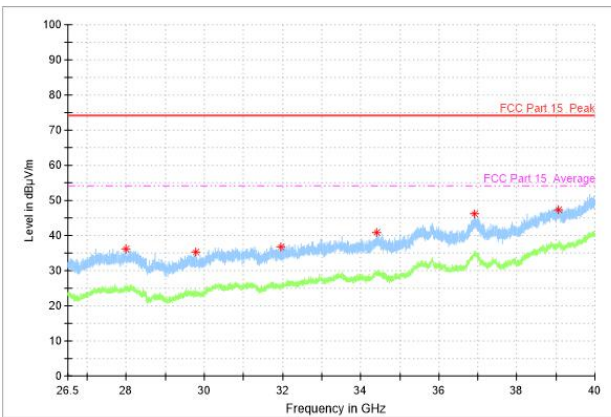

/

/

Radiated Spurious Emission
(802.11n-HT40, ch38, 30MHz-1GHz)

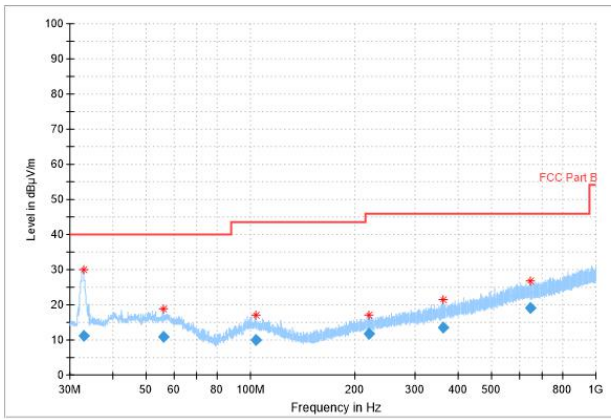

Radiated Spurious Emission
(802.11n-HT40, ch38, 1GHz-8GHz)

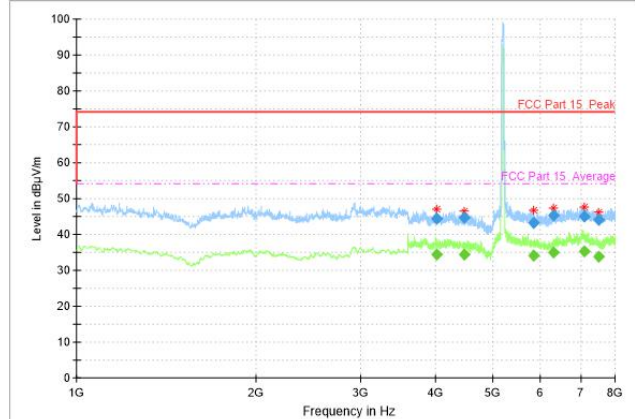

Radiated Spurious Emission
(802.11n-HT40, ch38, 8GHz-18GHz)

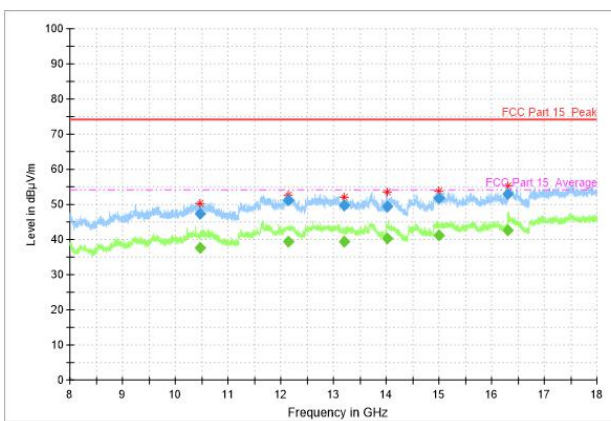

Radiated Spurious Emission
(802.11n-HT40, ch38, 18GHz-26.5GHz)

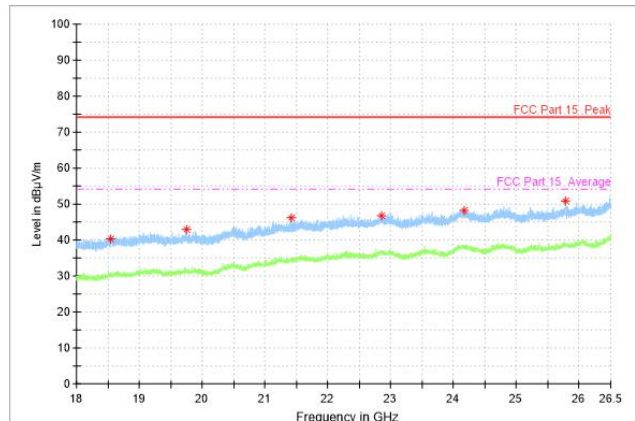

Radiated Spurious Emission
(802.11n-HT40, ch38, 26.5 GHz-40 GHz)

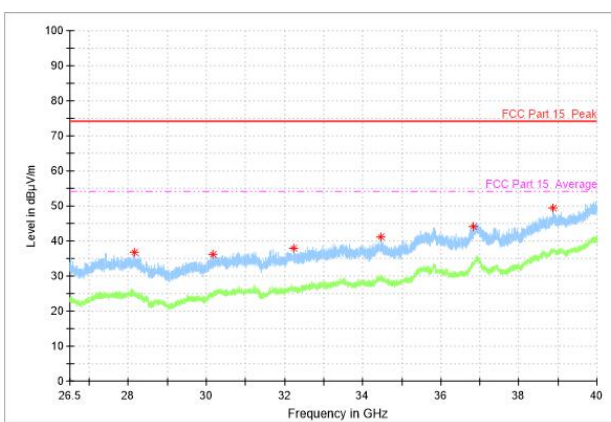

/

/

Radiated Spurious Emission
(802.11ac-VHT20, ch36, 30MHz-1GHz)

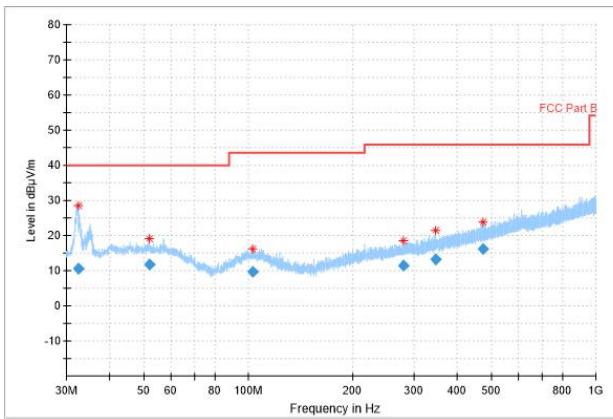

Radiated Spurious Emission
(802.11ac-VHT20, ch36, 1GHz-8GHz)

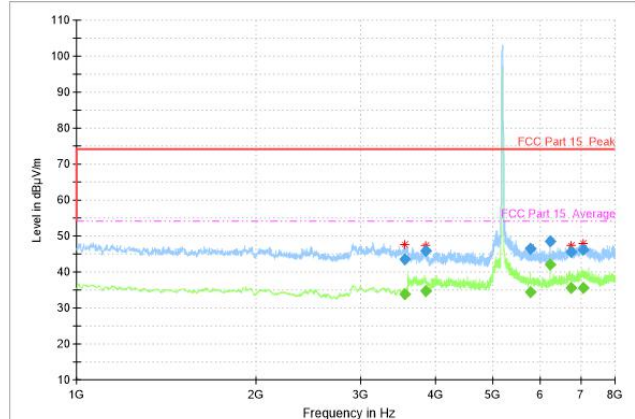

Radiated Spurious Emission
(802.11ac-VHT20, ch36, 8GHz-18GHz)

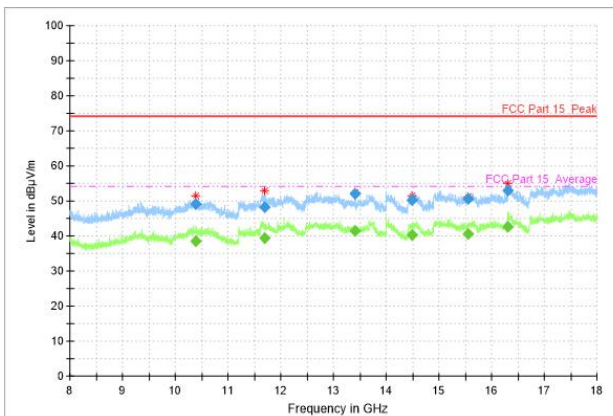

Radiated Spurious Emission
(802.11ac-VHT20, ch36, 18GHz-26.5GHz)

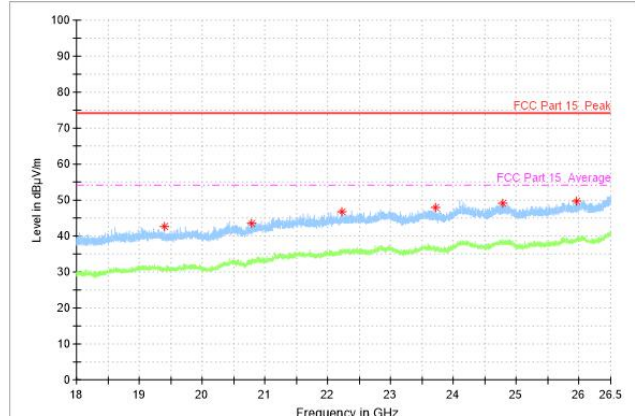

Radiated Spurious Emission
(802.11ac-VHT20, ch36, 26.5 GHz-40 GHz)

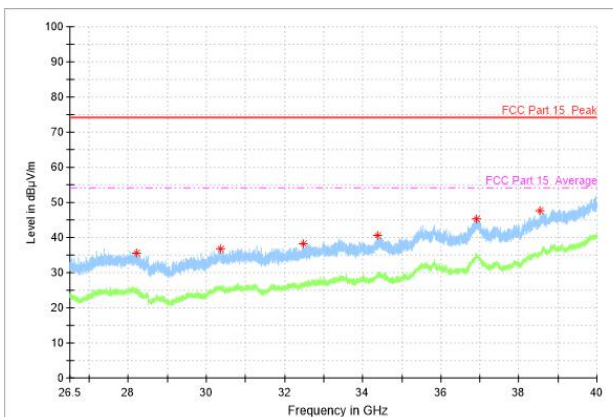

/

/

Radiated Spurious Emission
(802.11ac-VHT40, ch38, 30MHz-1GHz)

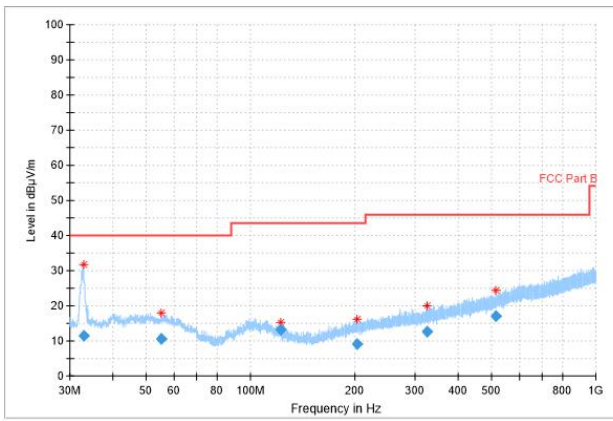

Radiated Spurious Emission
(802.11ac-VHT40, ch38, 1GHz-8GHz)

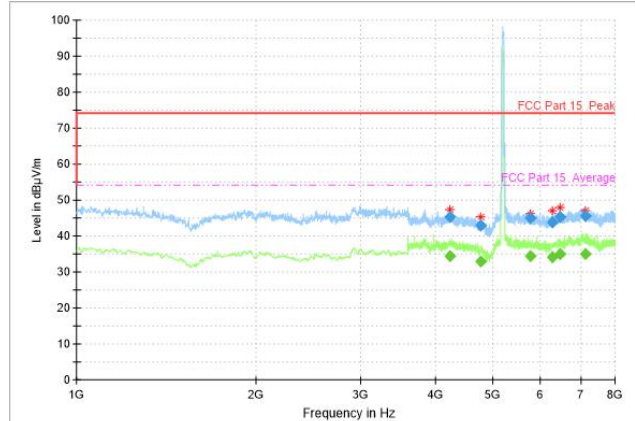

Radiated Spurious Emission
(802.11ac-VHT40, ch38, 8GHz-18GHz)

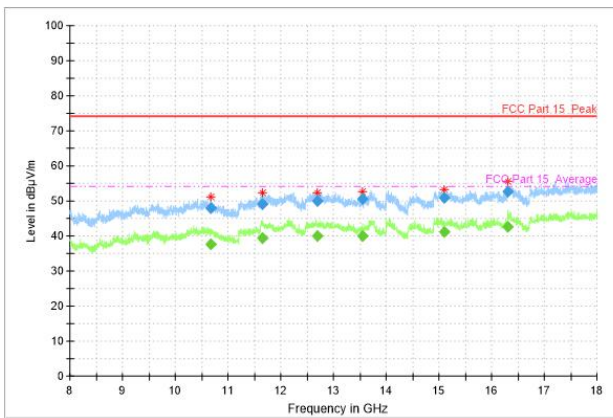

Radiated Spurious Emission
(802.11ac-VHT40, ch38, 18GHz-26.5GHz)

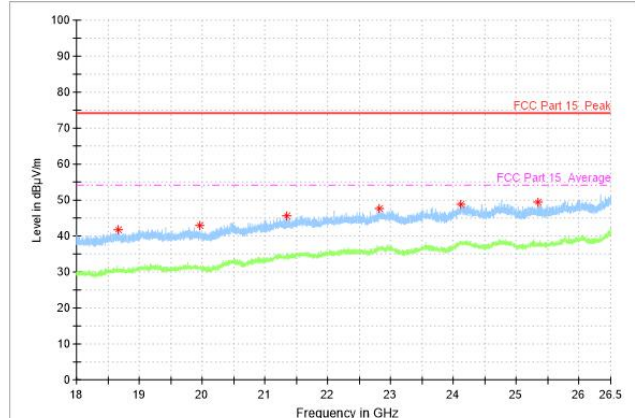

Radiated Spurious Emission
(802.11ac-VHT40, ch38, 26.5 GHz-40 GHz)

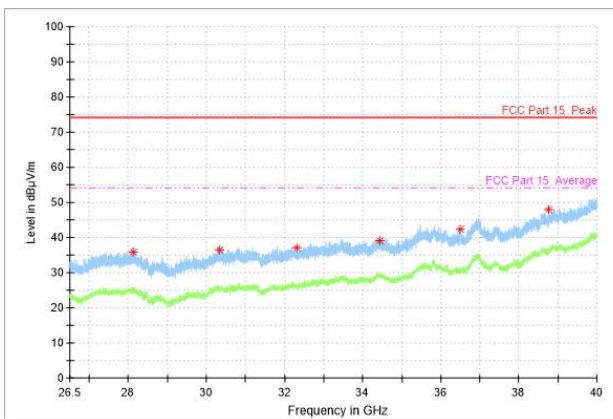

/

/

Note: The signal exceeding the limit is the main frequency signal.

U-NII-1

802.11a

Channel 36(30MHz ~1GHz)

Frequency(MHz)	Result(dBuV/m)	ARpl (dB)	PMea(dBuV/m)	Polarity
32.2	11.34	-14.3	25.64	V
57.6	11.11	-12.2	23.31	H
104.5	9.47	-13.3	22.77	V
289.5	11.52	-11	22.52	V
362.6	13.54	-9.1	22.64	H
447.4	15.55	-7.5	23.05	V

Channel 36(1GHz ~ 8GHz)

Frequency(MHz)	Result(dBuV/m)	ARpl (dB)	PMea(dBuV/m)	Polarity
2916.6	45.19	1.6	43.59	H
3874.8	45.52	1.6	43.92	H
5744.0	45.62	2.3	43.32	H
6363.0	46.03	2.8	43.23	H
6912.6	45.54	3.9	41.64	H
7469.8	44.7	3.4	41.3	H

Channel 36(8GHz ~ 18GHz)

Frequency(MHz)	Result(dBuV/m)	ARpl (dB)	PMea(dBuV/m)	Polarity
9213.0	45.99	5	40.99	H
10638.4	47.51	7.6	39.91	H
12234.8	51.1	10.8	40.3	H
13722.0	50.6	11.7	38.9	H
14937.8	53.07	13.8	39.27	H
16307.6	53.92	16.1	37.82	H

Channel 36(18GHz ~ 26.5GHz)

Frequency(MHz)	Result(dBuV/m)	ARpl (dB)	PMea(dBuV/m)	Polarity
18998.8	41.93	-4.5	46.43	H
20320.5	42.56	-4.2	46.76	H
21576.0	45.8	-2.2	48	H
22835.6	46.43	-0.6	47.03	H
24137.8	48.1	-0.1	48.2	H
25345.7	47.98	-0.2	48.18	V

Channel 36(26.5GHz ~ 40GHz)

Frequency(MHz)	Result(dBuV/m)	ARpl (dB)	PMea(dBuV/m)	Polarity
28487.2	34.92	-0.8	35.72	V
30528.4	35.77	0.9	34.87	V
32680.3	38.58	3.8	34.78	V
34409.6	40.36	4.6	35.76	V
36853.2	43.97	8.5	35.47	H
38797.2	47.15	11.3	35.85	V

802.11n-HT20

Channel 48(30MHz ~1GHz)

Frequency(MHz)	Result(dBuV/m)	ARpl (dB)	PMea(dBuV/m)	Polarity
32.2	10.95	-14.3	25.25	V
58.5	10.58	-12.2	22.78	H
122.7	13.51	-15.3	28.81	V
270.8	10.93	-11.1	22.03	V
337.9	12.9	-9.5	22.4	V
430.0	15.37	-7.7	23.07	V

Channel 48(1GHz ~ 8GHz)

Frequency(MHz)	Result(dBuV/m)	ARpl (dB)	PMea(dBuV/m)	Polarity
3553.6	45.19	1.2	43.99	H
4316.0	43.97	1.2	42.77	H
6046.4	45.51	2.3	43.21	H
6390.0	44.61	2.8	41.81	H
6654.4	45.36	3.6	41.76	H
7099.2	46.17	4.2	41.97	H

Channel 48(8GHz ~ 18GHz)

Frequency(MHz)	Result(dBuV/m)	ARpl (dB)	PMea(dBuV/m)	Polarity
9529.8	45.45	5.8	39.65	H
10714.0	48.99	7.5	41.49	H
12224.8	49.96	10.8	39.16	H
13691.0	51.97	11.6	40.37	H
14983.6	51.23	13.8	37.43	H

16002.0	52	15.1	36.9	H
---------	----	------	------	---

Channel 48 (18GHz ~ 26.5GHz)

Frequency(MHz)	Result(dBuV/m)	ARpl (dB)	PMea(dBuV/m)	Polarity
19320.0	41.97	-4.9	46.87	V
20784.6	43.26	-3.4	46.66	V
21940.6	46.07	-2.2	48.27	V
22982.7	46.73	-1.3	48.03	V
24044.4	48.3	-0.2	48.5	V
25347.4	48.43	-0.2	48.63	H

Channel 48(26.5GHz ~ 40GHz)

Frequency(MHz)	Result(dBuV/m)	ARpl (dB)	PMea(dBuV/m)	Polarity
27974.2	36.11	-0.2	36.31	H
29777.8	35.16	0.2	34.96	H
31964.8	36.89	2.1	34.79	H
34415.0	40.81	4.6	36.21	H
36904.4	46.23	8.4	37.83	V
39075.2	47.37	12.1	35.27	V

802.11n-HT40

Channel 38(30MHz ~1GHz)

Frequency(MHz)	Result(dBuV/m)	ARpl (dB)	PMea(dBuV/m)	Polarity
32.8	11.23	-14.2	25.43	V
55.9	10.87	-12.1	22.97	V
103.4	9.96	-13.3	23.26	V
220.9	11.82	-12.5	24.32	V
362.5	13.51	-9.1	22.61	H
645.2	19.17	-3.5	22.67	H

Channel 38(1GHz ~ 8GHz)

Frequency(MHz)	Result(dBuV/m)	ARpl (dB)	PMea(dBuV/m)	Polarity
4016.6	44.55	1.5	43.05	H
4465.4	44.63	1.5	43.13	H
5844.4	43.3	2.2	41.1	H
6305.4	45.3	3	42.3	H
7099.0	45.01	4.2	40.81	H

7520.2	44.05	3.2	40.85	H
--------	-------	-----	-------	---

Channel 38(8GHz ~ 18GHz)

Frequency(MHz)	Result(dBuV/m)	ARpl (dB)	PMea(dBuV/m)	Polarity
10477.6	47.26	7.5	39.76	H
12133.2	51.06	10.5	40.56	H
13210.6	49.71	10.8	38.91	H
14014.0	49.36	12.4	36.96	H
14998.0	51.88	13.7	38.18	H
16306.2	53.03	16.1	36.93	H

Channel 46(18GHz ~ 26.5GHz)

Frequency(MHz)	Result(dBuV/m)	ARpl (dB)	PMea(dBuV/m)	Polarity
18538.0	40.33	-4.5	44.83	V
19755.2	42.89	-4.4	47.29	V
21411.9	46.27	-2.3	48.57	H
22847.6	46.82	-0.6	47.42	H
24169.3	48.37	0	48.37	V
25782.6	51	0.8	50.2	H

Channel 38(26.5GHz ~ 40GHz)

Frequency(MHz)	Result(dBuV/m)	ARpl (dB)	PMea(dBuV/m)	Polarity
28145.6	36.79	1.1	35.69	V
30170.6	36.27	0.8	35.47	V
32224.0	37.86	2.6	35.26	H
34475.8	41.06	4.5	36.56	V
36834.2	44.23	8.5	35.73	H
38860.6	49.33	11.5	37.83	V

802.11ac-VHT20

Channel 36(30MHz ~1GHz)

Frequency(MHz)	Result(dBuV/m)	ARpl (dB)	PMea(dBuV/m)	Polarity
32.3	10.45	-14.2	24.65	V
51.8	11.75	-12	23.75	V
103.1	9.76	-13.3	23.06	H
279.9	11.5	-10.9	22.4	H
346.6	13.3	-9.4	22.7	V

473.7	16.09	-6.7	22.79	H
-------	-------	------	-------	---

Channel 36(1GHz ~ 8GHz)

Frequency(MHz)	Result(dBuV/m)	ARpl (dB)	PMea(dBuV/m)	Polarity
3553.2	43.41	1.2	42.21	H
3849.8	45.75	1.9	43.85	H
5771.4	46.52	2.2	44.32	H
6216.0	48.47	2.8	45.67	H
6739.8	45.52	3.7	41.82	H
7060.6	46.27	4.4	41.87	H

Channel 36(8GHz ~ 18GHz)

Frequency(MHz)	Result(dBuV/m)	ARpl (dB)	PMea(dBuV/m)	Polarity
10383.0	49.14	7.8	41.34	H
11689.4	48.36	10	38.36	H
13418.0	52.19	11.4	40.79	H
14498.4	50.43	12.6	37.83	H
15541.4	50.68	14.3	36.38	H
16301.6	53	16.1	36.9	H

Channel 36(18GHz ~ 26.5GHz)

Frequency(MHz)	Result(dBuV/m)	ARpl (dB)	PMea(dBuV/m)	Polarity
19398.2	42.79	-4.9	47.69	H
20786.3	43.53	-3.4	46.93	H
22221.1	46.62	-1.9	48.52	H
23706.0	47.96	-0.7	48.66	V
24779.6	49.11	0.4	48.71	V
25950.0	49.67	-0.5	50.17	V

Channel 36(26.5GHz ~ 40GHz)

Frequency(MHz)	Result(dBuV/m)	ARpl (dB)	PMea(dBuV/m)	Polarity
28215.8	35.62	0.4	35.22	H
30363.7	36.85	1.1	35.75	V
32472.4	38.09	3.3	34.79	V
34382.6	40.71	4.6	36.11	V
36919.3	45.4	8.4	37	H
38550.1	47.57	10.1	37.47	V

802.11ac-VHT40

Channel 38(30MHz ~1GHz)

Frequency(MHz)	Result(dBuV/m)	ARpl (dB)	PMea(dBuV/m)	Polarity
32.8	11.53	-14.2	25.73	V
55.2	10.62	-12.1	22.72	V
122.8	13.21	-15.4	28.61	V
203.1	9.14	-13.7	22.84	V
324.8	12.65	-9.7	22.35	H
513.2	16.96	-5.9	22.86	V

Channel 38(1GHz ~ 8GHz)

Frequency(MHz)	Result(dBuV/m)	ARpl (dB)	PMea(dBuV/m)	Polarity
4233.6	45.2	1.3	43.9	H
4760.0	42.85	1.5	41.35	H
5762.0	44.89	2.3	42.59	H
6282.6	43.85	2.9	40.95	H
6474.6	45.19	2.9	42.29	H
7126.2	45.68	4.2	41.48	H

Channel 38(8GHz ~ 18GHz)

Frequency(MHz)	Result(dBuV/m)	ARpl (dB)	PMea(dBuV/m)	Polarity
10670.6	48.03	7.6	40.43	H
11663.0	49.04	9.9	39.14	H
12692.4	49.87	10.8	39.07	H
13556.4	50.59	11.1	39.49	H
15112.2	50.81	13.6	37.21	H
16314.4	52.58	16.2	36.38	H

Channel 38(18GHz ~ 26.5GHz)

Frequency(MHz)	Result(dBuV/m)	ARpl (dB)	PMea(dBuV/m)	Polarity
18660.4	41.73	-4.9	46.63	H
19966.9	43.03	-4.6	47.63	V
21350.7	45.63	-2.5	48.13	V
22823.8	47.63	-0.7	48.33	V
24118.3	48.82	-0.1	48.92	H
25335.5	49.44	-0.1	49.54	V

Channel 38(26.5GHz ~ 40GHz)

Frequency(MHz)	Result(dBuV/m)	ARpl (dB)	PMea(dBuV/m)	Polarity
----------------	----------------	-----------	--------------	----------



28121.4	35.74	1.1	34.64	H
30317.8	36.5	1.1	35.4	V
32305.0	37.02	2.8	34.22	V
34424.5	39.26	4.6	34.66	V
36488.6	42.33	6.4	35.93	H
38751.2	47.84	11.1	36.74	H



6.7. Frequency Stability

Manufacturers ensured the EUT meet the requirement of frequency stability, such that an emission is maintained within the band of operation under all conditions of normal operation as specified in the user's manual.(According to 15.407(g) and RSS-Gen 8.11)

7. Test Equipment List

7.1. Conducted Test System

Item	Equipment Name	Type	Serial Number	Manufacturer	Cal. Date	Cal. interval
1	Vector Signal Analyzer	FSQ26	101091	R&S	2020-05-11	1 year
					2021-05-10	
2	DC Power Supply	ZUP60-14	LOC-220Z006 -0007	TDL-Lambda	2020-05-11	1 year
					2021-05-10	
3	Eagle Test Software	Eagle V3.1 FCC BT/WIFI	N/A	ECIT	N/A	N/A

7.2. Radiated Emission Test System

Item	Equipment Name	Type	Serial Number	Manufacturer	Cal. Date	Cal. interval
1	Universal Radio Communication Tester	CMU200	123123	R&S	2020-05-11	1 year
					2021-05-10	
2	EMI Test Receiver	ESU40	100307	R&S	2021-03-03	1 year
3	TRILOG Broadband Antenna	VULB9163	VULB9163-51 5	Schwarzbeck	2021-02-03	2 years
4	Double- ridged Waveguide Antenna	ETS-3117	00135890	ETS	2020-02-28	3 years
5	Universal Radio Communication Tester	CMW500	104178	R&S	2020-05-11	1 year
					2021-05-10	
6	EMI Test Software	EMC32 V 9.15.00	N/A	R&S	N/A	N/A

Anechoic chamber

Fully anechoic chamber by ETS.Measurement Uncertainty



Measurement uncertainty for all the testing in this report are within the limit specified in 3IN documents .
The detailed measurement uncertainty is defined in 3IN documents.

Measurement Items	Range	Confidence Level	Calculated Uncertainty
Peak Output Power-Conducted	5100MHz-5875MHz	95%	1.024dB
Peak Power Spectral Density	5100MHz-5875MHz	95%	1.024dB/MHz
Conducted Emission	30MHz-2GHz	95%	0.90dB
Conducted Emission	2GHz-3.6GHz	95%	0.88dB
Conducted Emission	3.6GHz-8GHz	95%	0.96dB
Conducted Emission	8GHz-20GHz	95%	0.94dB
Conducted Emission	20GHz-22GHz	95%	0.88dB
Conducted Emission	22GHz-26GHz	95%	0.86dB
Transmitter Spurious Emission-Radiated	9KHz-30MHz	95%	5.66dB
Transmitter Spurious Emission-Radiated	30MHz-1000MHz	95%	4.98dB
Transmitter Spurious Emission-Radiated	1000MHz -18000MHz	95%	5.06dB
Transmitter Spurious Emission-Radiated	18000MHz -40000MHz	95%	5.20dB
AC Power line Conducted Emission	0.15MHz-30MHz	95%	3.66 dB

Annex A: Accreditation Certificate



Accredited Laboratory

A2LA has accredited

INDUSTRIAL INTERNET INNOVATION CENTER (SHANGHAI) CO., LTD.

Shanghai, People's Republic of China

for technical competence in the field of

Electrical Testing

This laboratory is accredited in accordance with the recognized International Standard ISO/IEC 17025:2017 General requirements for the competence of testing and calibration laboratories. This accreditation demonstrates technical competence for a defined scope and the operation of a laboratory quality management system (refer to joint ISO-ILAC-IAF Communiqué dated April 2017).



Presented this 12th day of April 2021.

Vice President, Accreditation Services
For the Accreditation Council
Certificate Number 3682.01
Valid to February 28, 2023

For the tests to which this accreditation applies, please refer to the laboratory's Electrical Scope of Accreditation.

*****END OF REPORT*****