



TEST REPORT

Report Number: C21T00097-SRD02-V01

Applicant	Shanghai Sunmi Technology Co.,Ltd.
Product Name	Handheld Wireless Terminal
Model Name	T8A10
Brand Name	SUNMI
FCC ID	2AH25T8A10
IC	22621-T8A10

Industrial Internet Innovation Center (Shanghai) Co., Ltd. tested the above equipment in accordance with the requirements in FCC Part15, ANSI C63.10-2013, KDB 558074, RSS-Gen Issue 5, RSS-247 Issue 2.

Prepared by

Reviewed by

Approved by

Issue Date

2021-12-17

Industrial Internet Innovation Center (Shanghai) Co., Ltd.



NOTE

1. This report is invalid without the signature of the writer, reviewer and authorizer.
2. This report is invalid if altered.
3. For the benefit of clients, if you have any objection to the report, please inform the testing laboratory within 15 days from the date of receiving this report.
4. Samples in the test report are provided by the client. The test results are only applicable to the samples received by the laboratory. The source information of samples (such as sample sender, manufacturer, etc.) in the test report is provided by the client, and the laboratory is not responsible for its authenticity and the measurement accuracy.
5. The test report does not represent the identification of a product by a certification body or an authorized body.
6. This report is only valid as a whole, and no part of the report can be reproduced without the written approval of Industrial Internet Innovation Center (Shanghai) Co., Ltd.
7. Without the written permission of testing institutions and accreditation bodies, this report cannot be used in part or in whole for publicity or product introduction.
8. "N/A" is used in this report to indicate that it is not applicable or available.
9. Industrial Internet Innovation Center (Shanghai) Co., Ltd. assumes the legal responsibility for the report.
10. The measurement uncertainty is not taken into account when deciding conformity, and the results of measurement (or the average of measurement results) are directly used as the criterion for the stating conformity.

Test Laboratory:

Industrial Internet Innovation Center (Shanghai) Co., Ltd.
Add: Building 4, No. 766 Jingang Rd, Pudong, Shanghai, China
Tel: +86 21 68866880



Revision Version

Report Number	Revision	Date	Memo
C21T00097-SRD02-V00	00	2021-11-12	Initial creation of test report
C21T00097-SRD02-V01	01	2021-12-17	<ol style="list-style-type: none">1. FCC Rule Part Version has been update2. Fixed the description of Antenna Gain in section 6.7.3 to change gain to factor.3. RSS-GEN issue date has been update



CONTENTS

1. TEST LABORATORY.....	6
1.1. TESTING LOCATION.....	6
1.2. TESTING ENVIRONMENT.....	6
1.3. PROJECT INFORMATION.....	6
2. CLIENT INFORMATION.....	7
2.1. APPLICANT INFORMATION.....	7
2.2. MANUFACTURER INFORMATION.....	7
3. EQUIPMENT UNDER TEST (EUT) AND ANCILLARY EQUIPMENT (AE).....	8
3.1. ABOUT EUT.....	8
3.2. INTERNAL IDENTIFICATION OF EUT USED DURING THE TEST.....	8
3.3. INTERNAL IDENTIFICATION OF AE USED DURING THE TEST.....	8
4. REFERENCE DOCUMENTS.....	9
4.1. REFERENCE DOCUMENTS FOR TESTING.....	9
4.2. REFERENCE INFORMATION FROM CLIENT.....	9
5. TEST SUMMARY.....	10
5.1. SUMMARY OF TEST RESULTS.....	10
5.2. STATEMENTS.....	11
6. MEASUREMENT RESULTS.....	12
6.1. PEAK OUTPUT POWER-CONDUCTED.....	13
6.2. 99% OCCUPIED BANDWIDTH.....	16
6.3. PEAK POWER SPECTRAL DENSITY.....	19
6.4. 6DB BANDWIDTH.....	22
6.5. FREQUENCY BAND EDGES-CONDUCTED.....	25



6.6. CONDUCTED EMISSION.....	27
6.7. RADIATED EMISSION.....	31
7. TEST EQUIPMENT LIST.....	41
7.1. CONDUCTED TEST SYSTEM.....	41
7.2. RADIATED EMISSION TEST SYSTEM.....	41
ANNEX A: MEASUREMENT UNCERTAINTY.....	42
ANNEX B: ACCREDITATION CERTIFICATE.....	43

1. Test Laboratory

1.1. Testing Location

Primary Lab:

Company Name	Industrial Internet Innovation Center (Shanghai) Co., Ltd.
Address	Building 4, No. 766 Jingang Rd, Pudong, Shanghai, China
FCC Registration No.	958356
FCC Designation No.	CN1177
IC designation No.	CN0067

Subcontracting Lab #1:

Company Name	N/A
Address	N/A

1.2. Testing Environment

Normal Temperature	15°C~35°C
Relative Humidity	30%RH~60%RH
Supply Voltage	120V/60Hz

1.3. Project Information

Project Leader	Wang Wenwen
Testing Start Date	2021-08-05
Testing End Date	2021-10-22



2. Client Information

2.1. Applicant Information

Company Name	Shanghai Sunmi Technology Co.,Ltd.
Address	Room 505, KIC Plaza, No.388 Song Hu Road, Yang Pu District, Shanghai, China
Telephone	+86 18501703215

2.2. Manufacturer Information

Company Name	Shanghai Sunmi Technology Co.,Ltd.
Address	Room 505, KIC Plaza, No.388 Song Hu Road, Yang Pu District, Shanghai, China
Telephone	+86 18501703215

3. Equipment under Test (EUT) and Ancillary Equipment (AE)

3.1. About EUT

Product Name	Handheld Wireless Terminal
Model name	T8A10
Supported Radio Technology and Bands	GSM850/GSM900/DCS1800/PCS1900 WCDMA Band I/II/ IV/V/VIII LTE Band 1/2/3/4/5/7/12/13/17/18/19/25/26/38/41/66/71 BT 5.0,BLE WLAN 802.11b,g,n WLAN 802.11a,n,ac NFC GPS
Hardware Version	V4
Software Version	V025
FCC ID	2AH25T8A10
IC	22621-T8A10

Note: Photographs of EUT are shown in ANNEX B of this test report.

3.2. Internal Identification of EUT used during the test

EUT ID*	SN or IMEI	HW Version	SW Version	Date of Receipt
N01	866584051015648 866584051015655	V4	V025	2021-08-04
N02	866584051015721 866584051015739	V4	V025	2021-08-04
N08	866584051015747 866584051015754	V4	V025	2021-08-04

*EUT ID: is internally used to identify the test sample in the lab.

3.3. Internal Identification of AE used during the test

AE ID*	Description	Model	SN/Remark
AE1	RF Cable	N/A	N/A

*AE ID: is internally used to identify the test sample in the lab.

*The AE is provided by the client.

4. Reference Documents

4.1. Reference Documents for testing

The following documents listed in this section are referred for testing.

Reference	Title	Version
FCC Part15	FCC CFR 47, Part 15, Subpart C: 15.205 Restricted bands of operation; 15.209 Radiated emission limits, general requirements; 15.247 Operation within the bands 902-928MHz, 2400-2483.5MHz, and 5725-5850MHz.	2020-10-01
ANSI C63.10	American National Standard of Procedures for Compliance Testing of Unlicensed Wireless Devices	2013
KDB 558074	Guidance for Performing Compliance Measurements on Frequency Hopping Spread Spectrum systems (DSS) Operating Under §15.247	v05r02
RSS-247 Issue 2	Digital Transmission Systems (DTSs), Frequency Hopping Systems (FHSs) and Licence-Exempt Local Area Network (LE-LAN) Devices	2017
RSS-Gen Issue 5	General Requirements for Compliance of Radio Apparatus	2021

4.2. Reference Information from client

Information of the test sample provided by the client.

Antenna gain of EUT 3 dBi

Note: The product T8A10 use an integral antenna which compliance with the requirement of 15.203.

5. Test Summary

5.1. Summary of Test Results

Measurement Items	Sub-clause of Part15C	Sub-clause of IC	Verdict
Maximum Peak Output Power	15.247(b)	RSS-247 5.4	Pass
Peak Power Spectral Density	15.247(e)	RSS-247 5.2	Pass
6dB Occupied Bandwidth	15.247(a)	RSS-247 5.2	Pass
99% Occupied Bandwidth	N/A	RSS-Gen 6.7	Pass
Band Edges Compliance	15.247(d)	RSS-247 5.5	Pass
Transmitter Spurious Emission-Conducted	15.247(d)	RSS-247 5.5	Pass
Transmitter Spurious Emission-Radiated	15.247/15.205/15.209	RSS-Gen 8.9,8.10	Pass

Test Conditions

Tnom	Normal Temperature
Tmin	Low Temperature
Tmax	High Temperature
Vnom	Normal Voltage
Vmin	Low Voltage
Vmax	High Voltage
Hnom	Norm Humidity
Anom	Norm Air Pressure

For this report, all the test case listed above are tested under Normal Temperature and Normal Voltage, and also under norm humidity, the specific conditions as following:

Temperature	Tnom	25°C
Voltage	Vnom	3.8V
Humidity	Hnom	48%
Air Pressure	Anom	1010hPa

Note:

a. All the test data for each data were verified, but only the worst case was reported.



5.2. Statements

The T8A10 manufactured by Shanghai Sunmi Technology Co.,Ltd., Incorporated are new products for testing.

Industrial Internet Innovation Center (Shanghai) Co., Ltd. only performed test cases which identified with Pass/Fail/Inc result in section 5.1.

Industrial Internet Innovation Center (Shanghai) Co., Ltd. has verified that the compliance of the tested device specified in section 3 of this test report is successfully evaluated according to the procedure and test methods as defined in type certification requirement listed in section 4 of this test report.

6. Measurement Results

Shielding Room1 (6.0 meters×3.0 meters×2.7 meters) did not exceed following limits along the conducted RF performance testing:

Temperature	Min. = 15 °C, Max. = 35 °C
Relative humidity	Min. = 20 %, Max. = 75 %
Shielding effectiveness	> 100 dB
Ground system resistance	< 0.5
Temperature	Min. = 15 °C, Max. = 35 °C

Control room did not exceed following limits along the EMC testing:

Temperature	Min. = 15 °C, Max. = 35 °C
Relative humidity	Min. =30 %, Max. = 60 %
Shielding effectiveness	> 100 dB
Electrical insulation	> 10 k
Ground system resistance	< 0.5

Fully-anechoic chamber1 (6.9 meters×10.9 meters×5.4 meters) did not exceed following limits along the EMC testing:

Temperature	Min. = 15 °C, Max. = 35 °C
Relative humidity	Min. = 25 %, Max. = 75 %
Shielding effectiveness	> 100 dB
Electrical insulation	> 10 k
Ground system resistance	< 0.5
VSWR	Between 0 and 6 dB, from 1GHz to 18GHz
Site Attenuation Deviation	Between -4 and 4 dB,30MHz to 1GHz
Uniformity of field strength	Between 0 and 6 dB, from 80MHz to 3000 MHz

6.1. Peak Output Power-Conducted

6.1.1. Measurement Limit

Standard	Limit (dBm)
FCC 47 Part 15.247(b)(3)	<30
RSS-247 5.4(d)	<30

6.1.2. Test Condition

DTS procedure	RBW	VBW	Span	Sweeptime
BT-LE	3MHz	10MHz	9MHz	Auto

6.1.3. Test procedure

The measurement is according to ANSI C63.10 clause 11.9.1

- a) Set the RBW \geq DTS bandwidth.
- b) Set VBW \geq [3 \times RBW].
- c) Set span \geq [3 \times RBW].
- d) Sweep time = auto couple.
- e) Detector = peak.
- f) Trace mode = max hold.
- g) Allow trace to fully stabilize.
- h) Use peak marker function to determine the peak amplitude level.

6.1.4. Test Setup

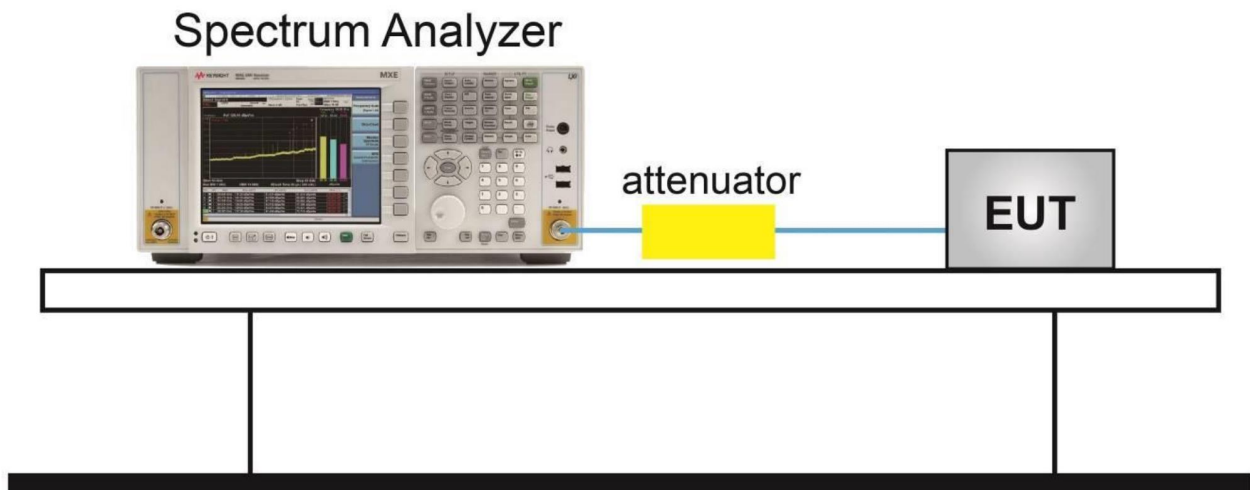

Measurement Results

1M

<p>Peak Conducted Output Power CH0 (dBm)</p>	<p>4.27</p>	<p>Peak Conducted Output Power CH19 (dBm)</p>	<p>4.93</p>
<p>Date: 26.AUG.2021 15:28:08</p>		<p>Date: 26.AUG.2021 15:29:15</p>	
<p>Peak Conducted Output Power CH39 (dBm)</p>	<p>3.57</p>	<p>/</p>	<p>/</p>
<p>Date: 26.AUG.2021 15:30:00</p>			

2M

<p>Peak Conducted Output Power CH0 (dBm)</p>	<p>4.35</p>	<p>Peak Conducted Output Power CH19 (dBm)</p>	<p>4.97</p>
<p>Peak Conducted Output Power CH39 (dBm)</p>	<p>3.64</p>	<p>/</p>	<p>/</p>

6.2. 99% Occupied Bandwidth

6.2.1. Measurement Limit

Standard	Limit
RSS-Gen 6.7	N/A

6.2.2. Test procedures

The measurement is according to ANSI C63.10 clause 6.9.3.

1. The output power of EUT was connected to the spectrum analyzer. The path loss was compensated to the results for each measurement.
2. Enable EUT transmitter maximum power continuously.
3. Set RBW shall be in the range of 1% to 5% of the OBW.
4. Set the VBW $\geq [3 \times \text{RBW}]$.
5. Detector = peak.
6. Trace mode = max hold.
7. Sweep = auto couple.
8. Allow the trace to stabilize.
9. The occupied bandwidth is the frequency bandwidth such that, below its lower and above its upper frequency limits, the mean powers are each equal to 0.5% of the total mean power of the given emission.

6.2.3. Test Setup

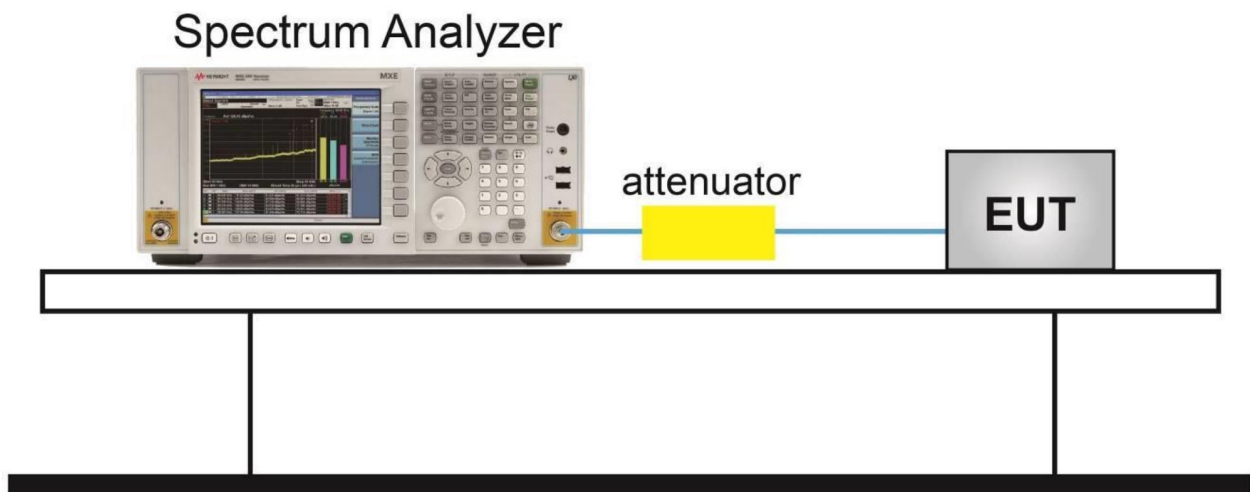



Measurement Result

1M

Modulation type	Channel	99% Bandwidth (MHz)
GFSK DH5	Ch 0	1.029
	Ch 19	1.034
	Ch 39	1.034

Test graphs as below

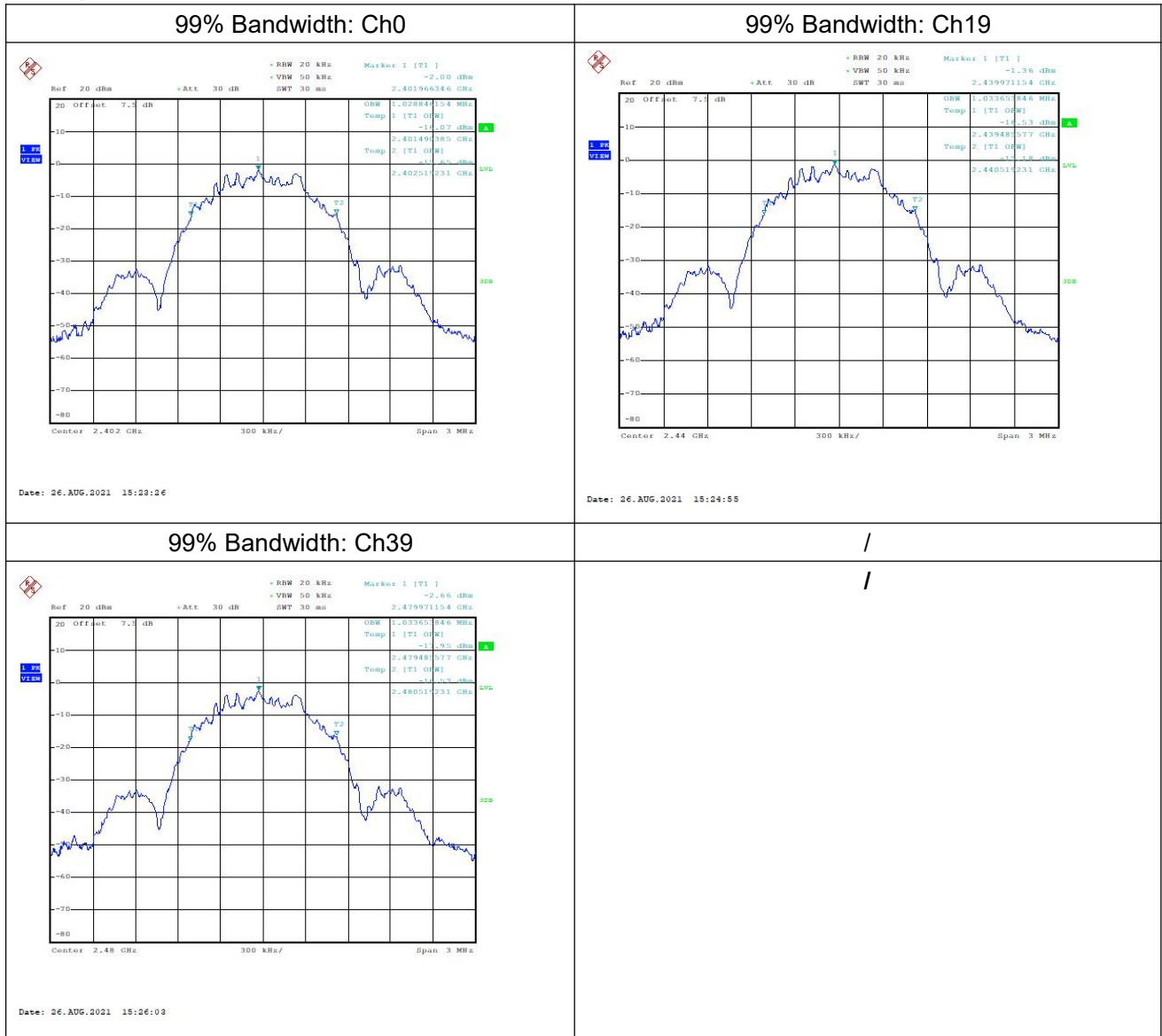



2M

Modulation type	Channel	99% Bandwidth (MHz)
GFSK DH5	Ch 0	2.067
	Ch 19	2.067
	Ch 39	2.058

Test graphs as below

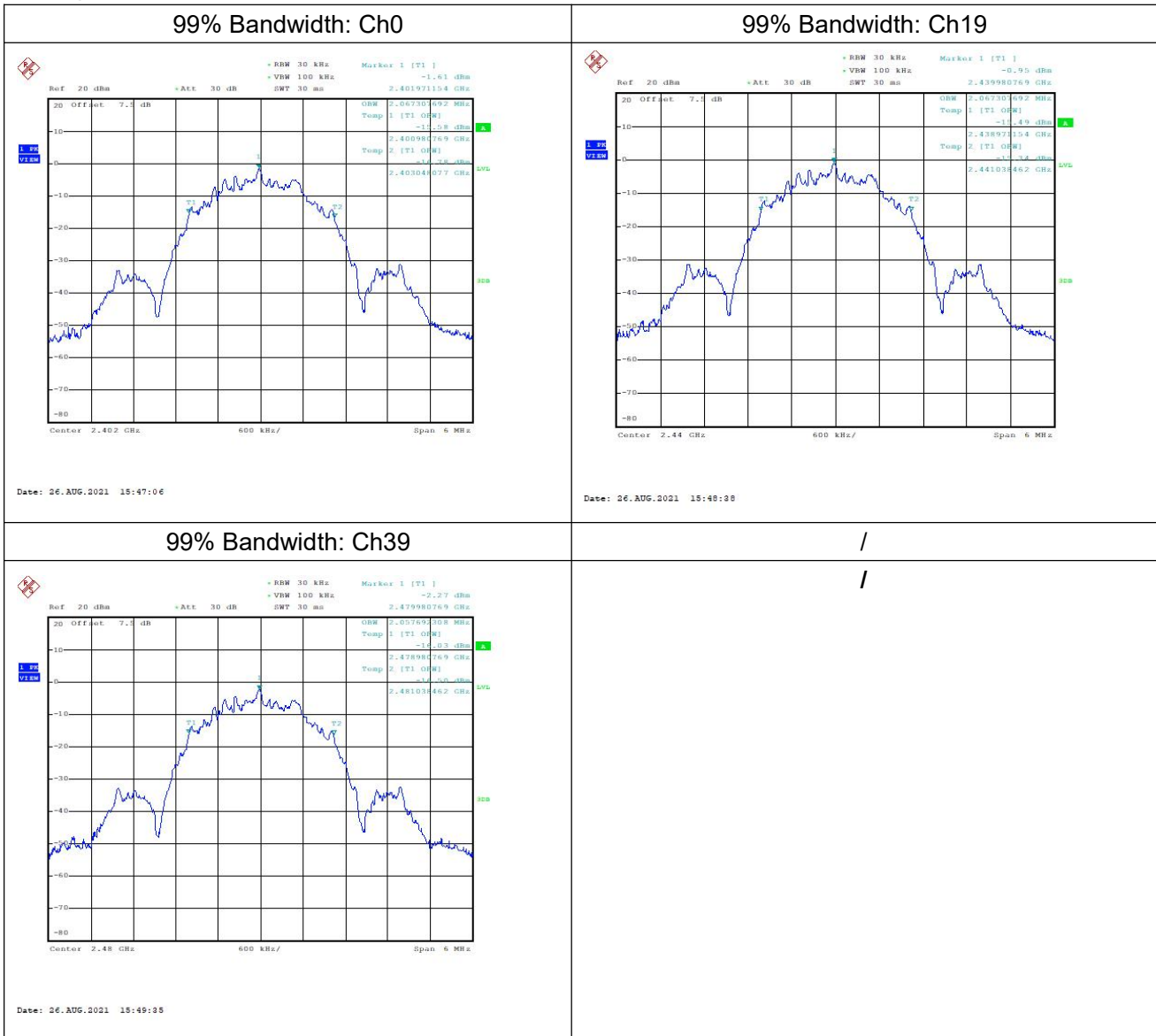

6.3. Peak Power Spectral Density

6.3.1. Measurement Limit

Standard	Limit
FCC 47 Part 15.247(e)	$\leq 8\text{dBm}/3\text{ kHz}$
RSS-247 5.2(b)	$\leq 8\text{dBm}/3\text{ kHz}$

6.3.2. Test procedures

The measurement is according to ANSI C63.10 clause 11.10.

1. The output power of EUT was connected to the spectrum analyzer. The path loss was compensated to the results for each measurement.
2. Enable EUT transmitter maximum power continuously.
3. Set analyzer center frequency to DTS channel center frequency.
4. Set the span to 1.5 times the DTS bandwidth.
5. Set the RBW to $3\text{ kHz} \leq \text{RBW} \leq 100\text{ kHz}$.
6. Set the VBW $\geq [3 \times \text{RBW}]$.
7. Detector = peak.
8. Sweep time = auto couple.
9. Trace mode = max hold.
10. Allow trace to fully stabilize.
11. Use the peak marker function to determine the maximum amplitude level within the RBW.
12. If measured value exceeds requirement, then reduce RBW (but no less than 3 kHz) and repeat.

6.3.2. Test Setup

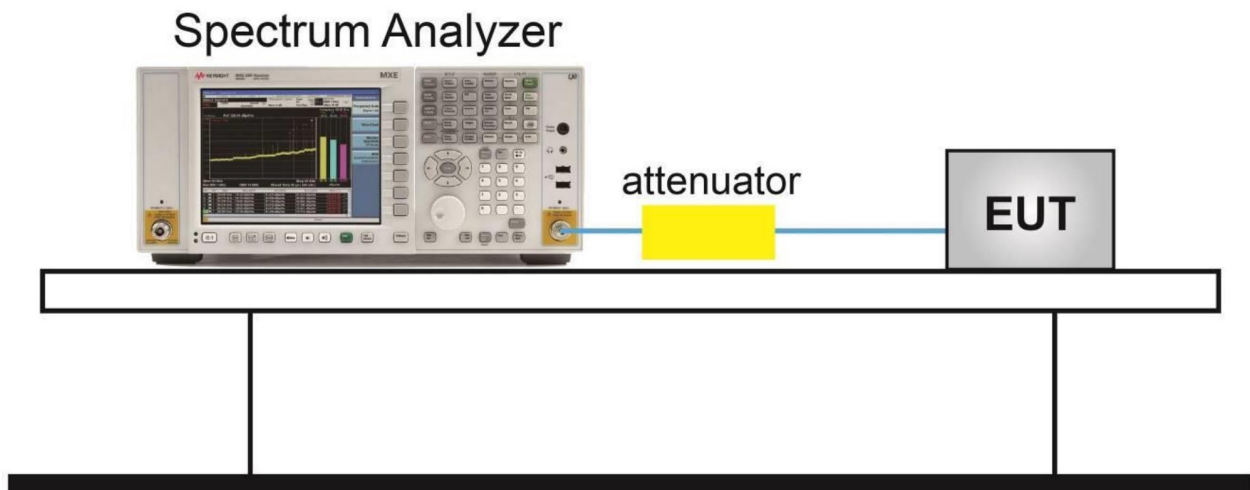

Measurement Results

1M

Modulation type	Channel	PSD (dBm/3kHz)
GFSK DH5	Ch 0	-12.582
	Ch 19	-12.04
	Ch 39	-13.267

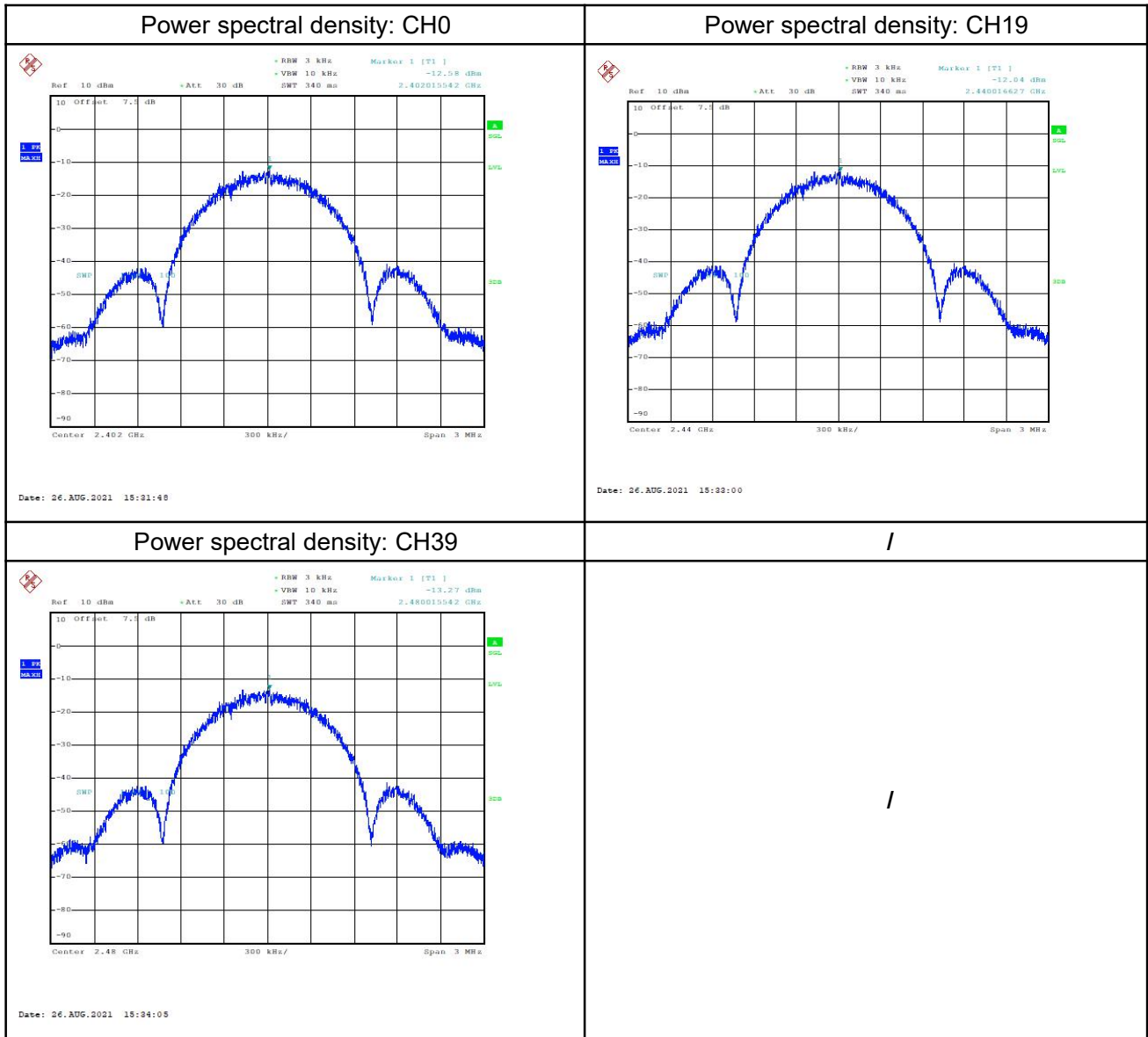

2M

Modulation type	Channel	PSD (dBm/3kHz)
GFSK DH5	Ch 0	-15.168
	Ch 19	-14.277
	Ch 39	-15.621

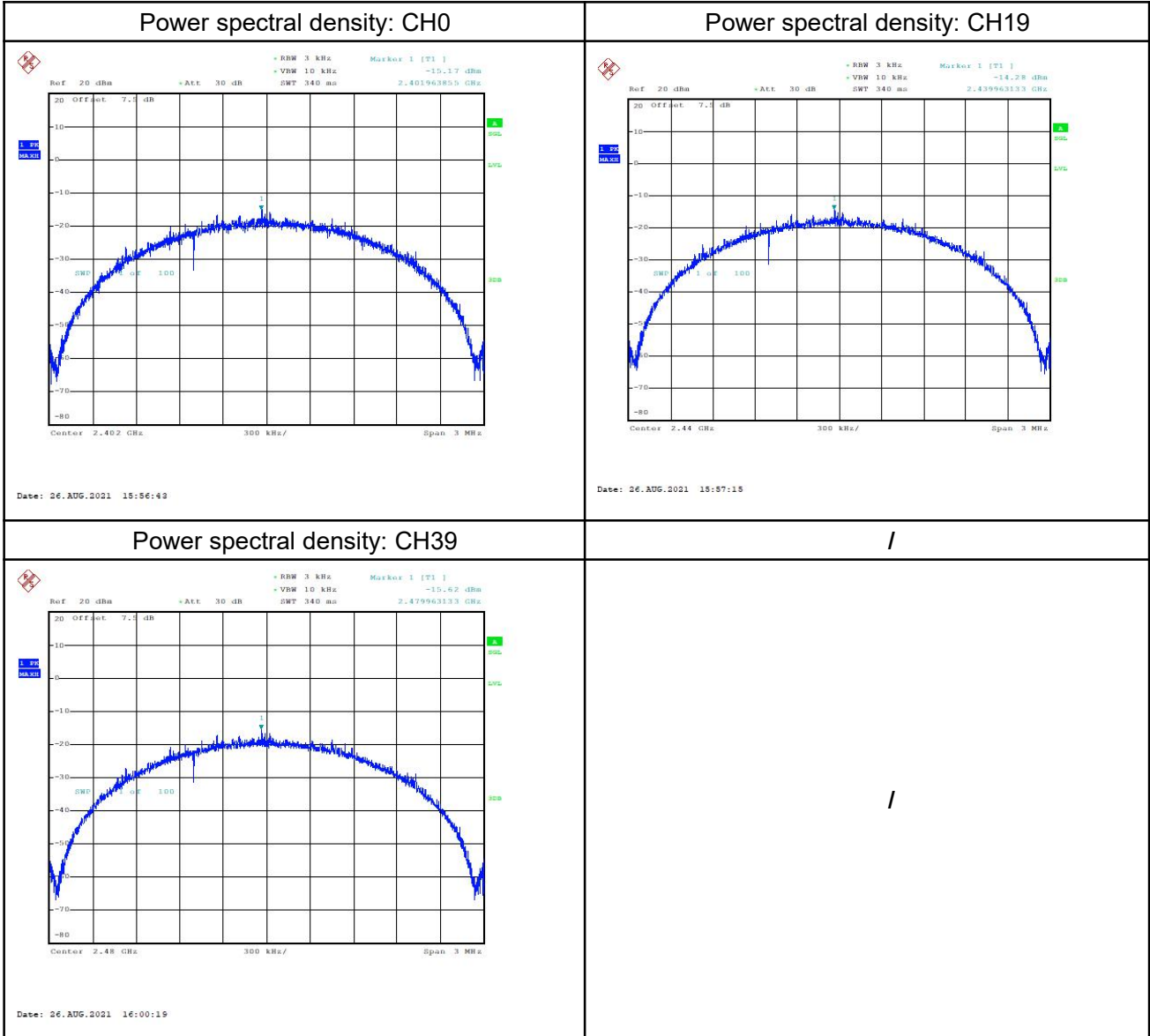

6.4. 6dB Bandwidth

6.4.1. Measurement Limit

Standard	Limit
FCC 47 Part 15.247 (a) (2)	$\geq 500\text{kHz}$
RSS-247 5.2(a)	$\geq 500\text{kHz}$

6.4.2. Test procedures

The measurement is according to ANSI C63.10 clause 11.8.

1. The output power of EUT was connected to the spectrum analyzer. The path loss was compensated to the results for each measurement.
2. Enable EUT transmitter maximum power continuously.
3. Set RBW = 100 kHz.
4. Set the VBW $\geq [3 \times \text{RBW}]$.
5. Detector = peak.
6. Trace mode = max hold.
7. Sweep = auto couple.
8. Allow the trace to stabilize.
9. Measure the maximum width of the emission that is constrained by the frequencies associated with the two outermost amplitude points (upper and lower frequencies) that are attenuated by 6 dB relative to the maximum level measured in the fundamental emission.

6.4.3. Test Setup

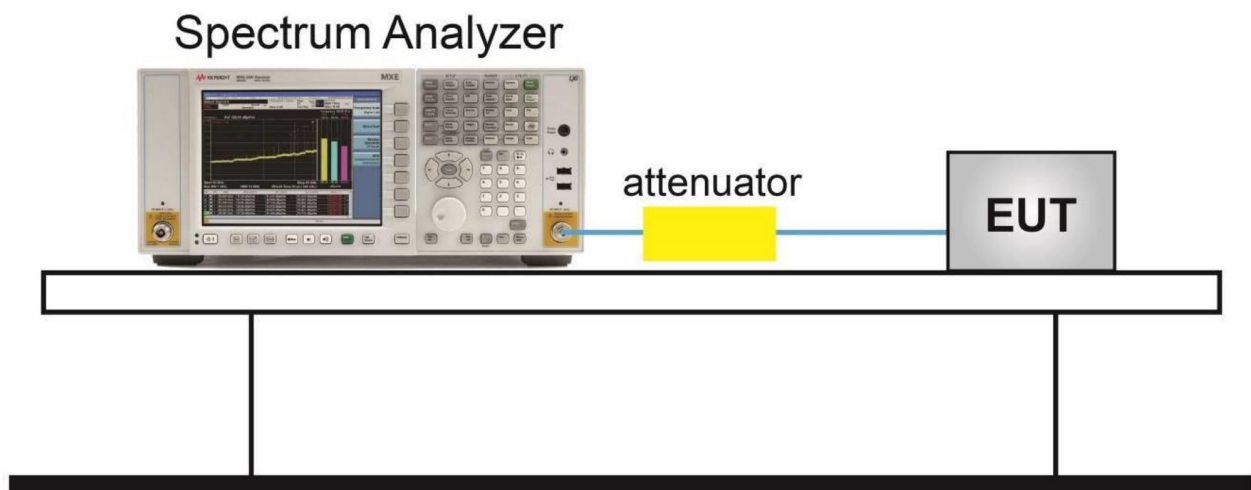



Measurement Result

1M

Modulation type	Channel	6dB Bandwidth (kHz)
GFSK DH5	Ch 0	668
	Ch 19	678
	Ch 39	673

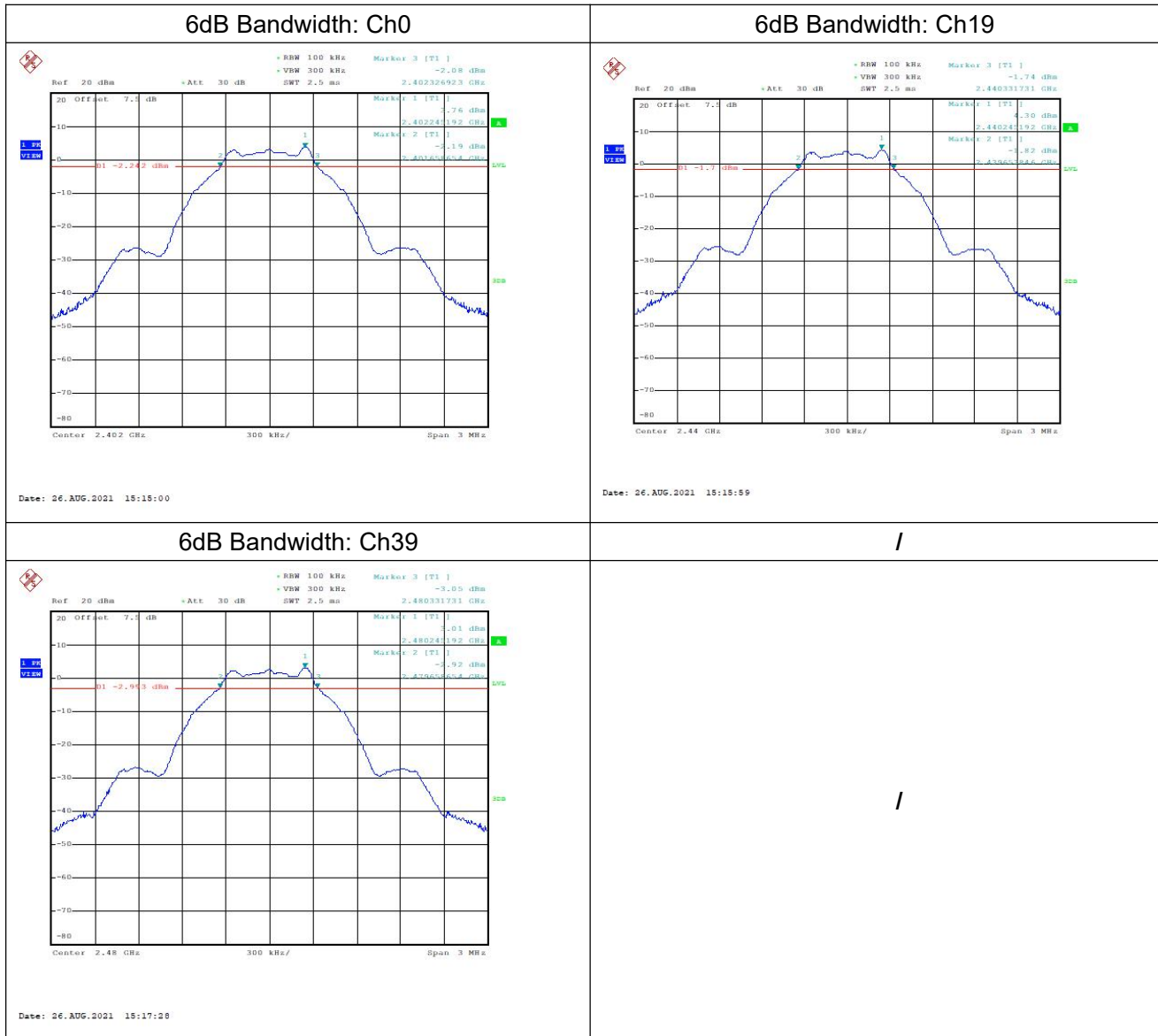

1M

Modulation type	Channel	6dB Bandwidth (kHz)
GFSK DH5	Ch 0	1173
	Ch 19	1173
	Ch 39	1154

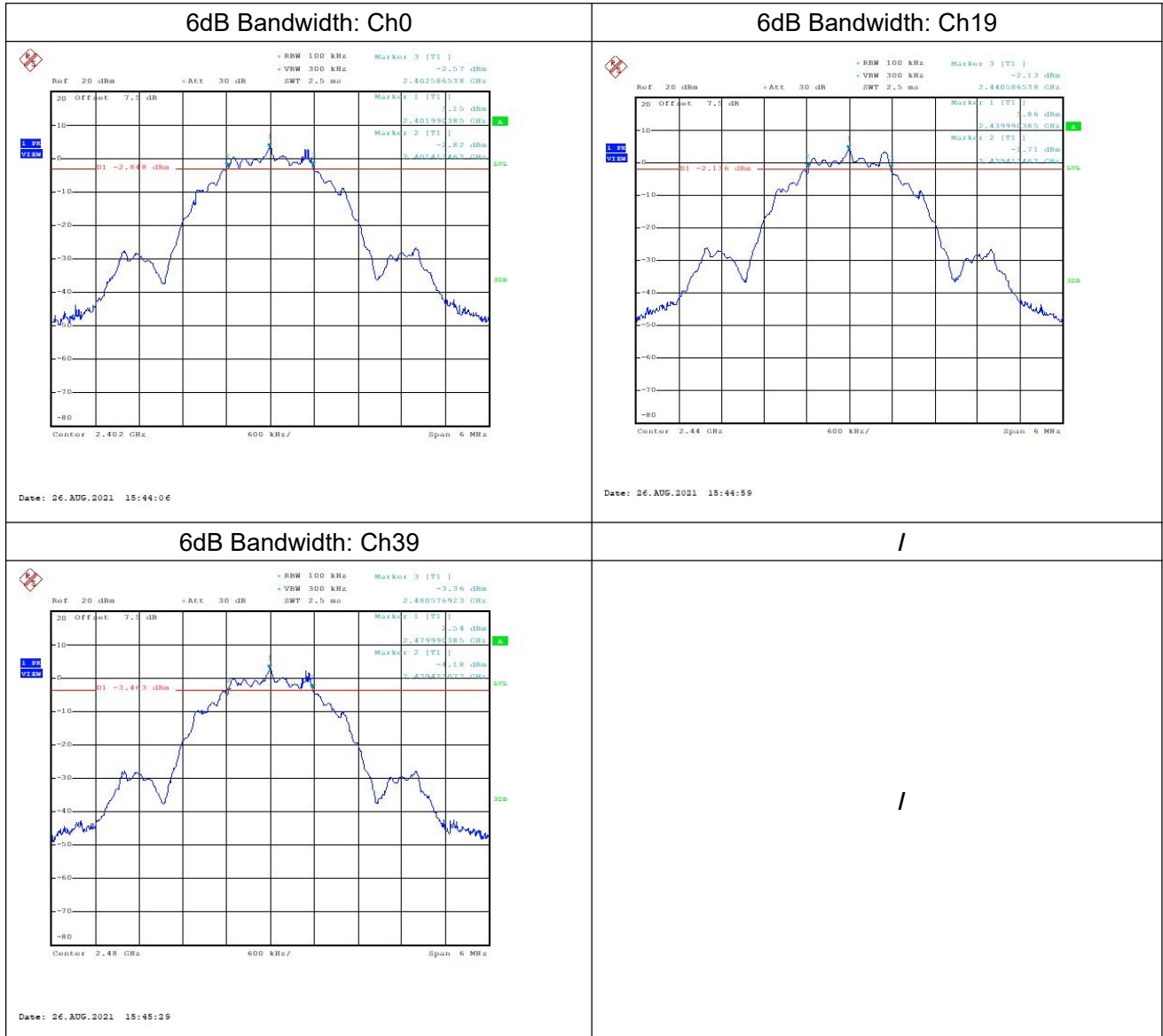

6.5. Frequency Band Edges-Conducted

6.5.1. Measurement Limit

Standard	Limited(dBc)
FCC 47 Part 15.247(d)	>20
RSS-247 5.5	>20

6.5.2. Test procedure

The measurement is according to ANSI C63.10 clause 11.13.2

- 1) Span: Wide enough to capture the peak level of the emission operating on the channel closest to the band edge, as well as any modulation products that fall outside of the authorized band of operation.
- 2) Reference level: As required to keep the signal from exceeding the maximum instrument input mixer level for linear operation. In general, the peak of the spectral envelope shall be more than [10 log (OBW/RBW)] below the reference level. Specific guidance is given in 4.1.5.2.
- 3) Attenuation: Auto (at least 10 dB preferred).
- 4) Sweep time: Coupled.
- 5) Resolution bandwidth: 100 kHz.6) Video bandwidth: 300 kHz.7) Detector: Peak.8) Trace: Max hold.

6.5.3. Test Setup

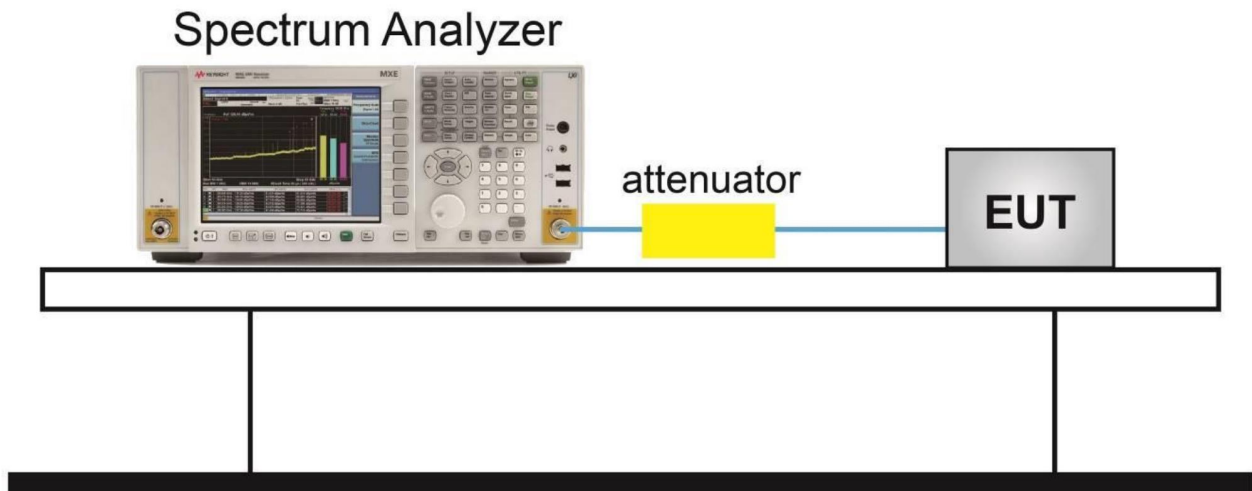

Measurement results

1M

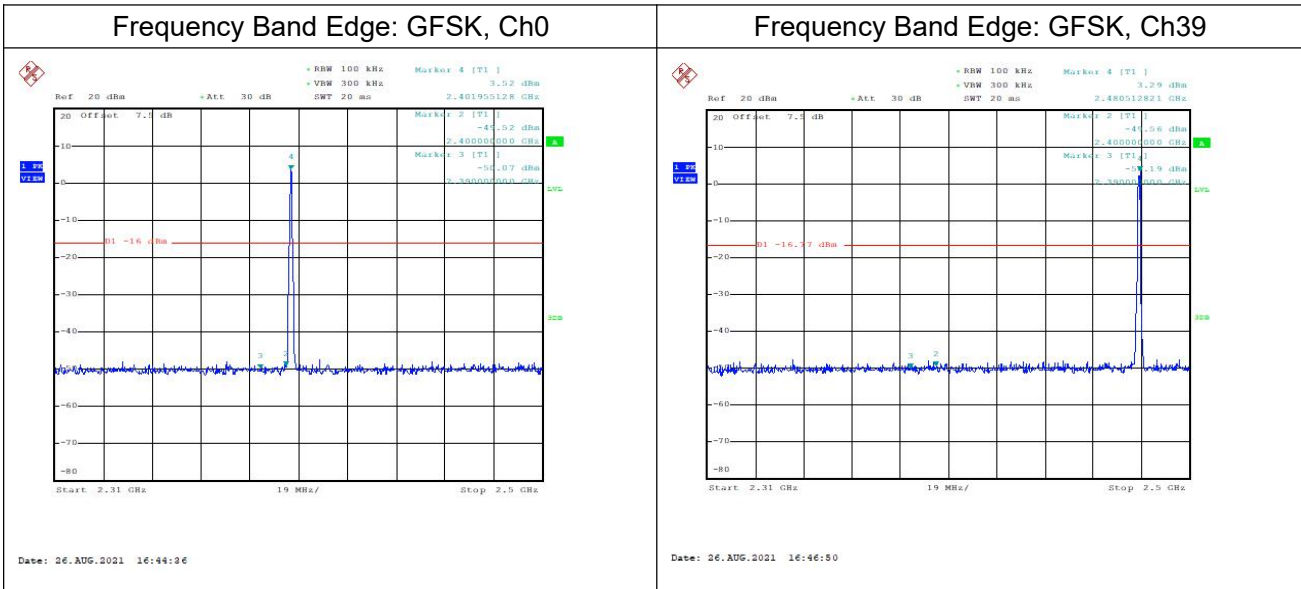

2M

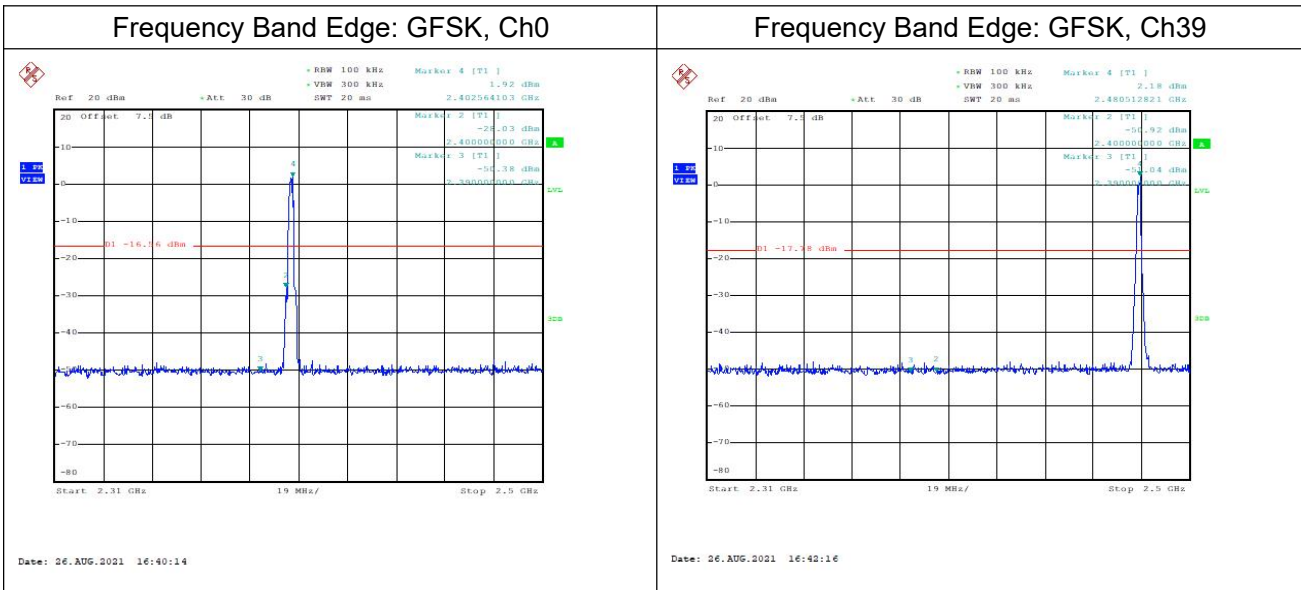

6.6. Conducted Emission

6.6.1. Measurement Limit

Standard	Limit
FCC 47 Part15.247 (d)	20dB below peak output power in 100KHz bandwidth
RSS-247 5.5	20dB below peak output power in 100KHz bandwidth

6.6.2. Test procedures

This measurement is according to ANSI C63.10 clause 11.11.

1. The output power of EUT was connected to the spectrum analyzer. The path loss was compensated to the results for each measurement.
2. Enable EUT transmitter maximum power continuously.

Reference level measurement

3. Set instrument center frequency to DTS channel center frequency.
4. Set the span to ≥ 1.5 times the DTS bandwidth.
5. Set the RBW = 100 kHz.
6. Set the VBW $\geq [3 \times \text{RBW}]$.
7. Detector = peak.
8. Sweep time = auto couple.
9. Trace mode = max hold.
10. Allow trace to fully stabilize.
11. Use the peak marker function to determine the maximum PSD level.

Emission level measurement

12. Set the center frequency and span to encompass frequency range to be measured.
13. Set the RBW = 100 kHz.
14. Set the VBW $\geq [3 \times \text{RBW}]$.
15. Detector = peak.
16. Sweep time = auto couple.
17. Trace mode = max hold.
18. Allow trace to fully stabilize.
19. Use the peak marker function to determine the maximum amplitude level.

6.6.3. Test Setup

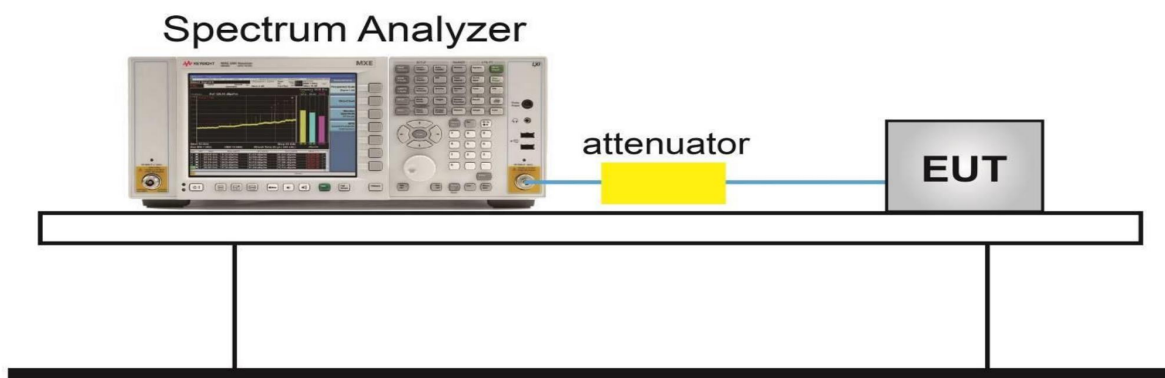

Measurement Results

1M

Conducted spurious emission: Ch0, 2402MHz

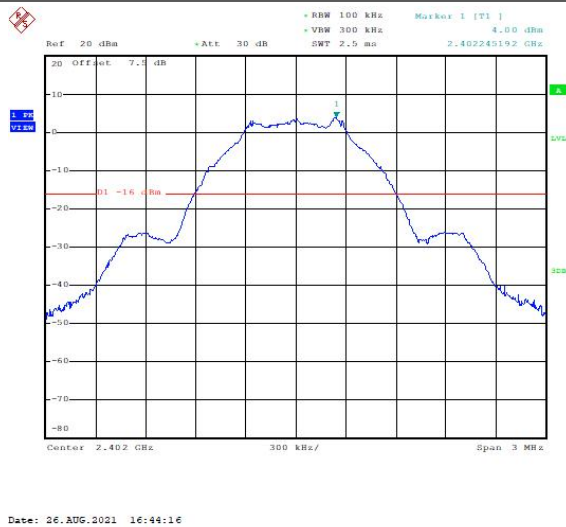

Conducted spurious emission: Ch0, 30MHz~26GHz

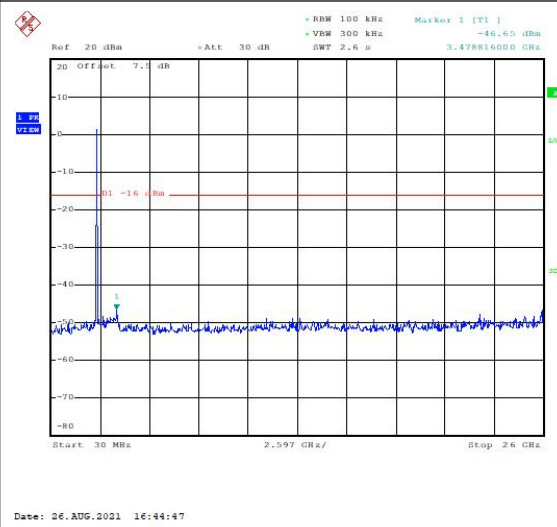

Conducted spurious emission: Ch19, 2441MHz

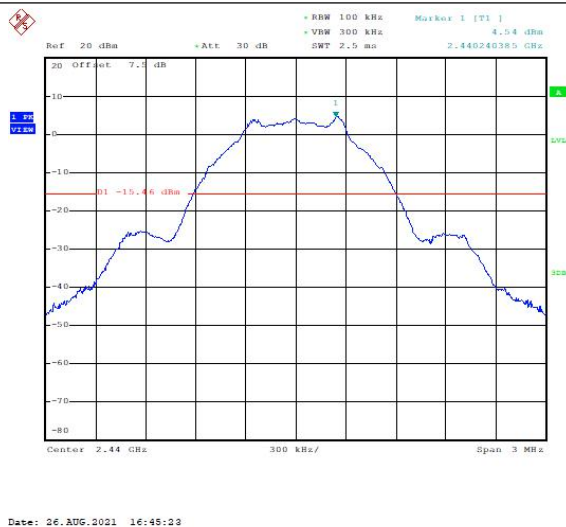

Conducted spurious emission: Ch19, 30MHz~26GHz

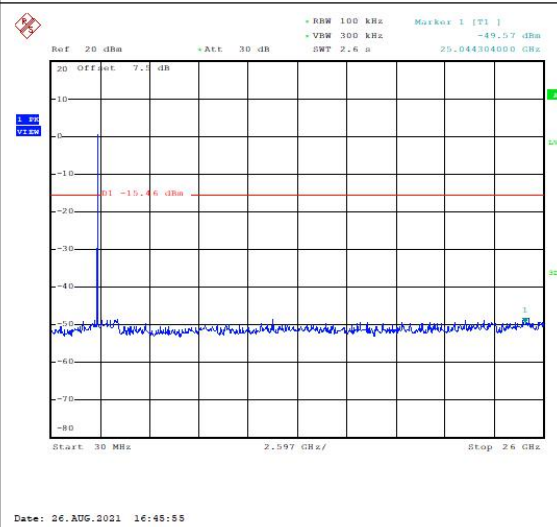

Conducted spurious emission: Ch39, 2480MHz

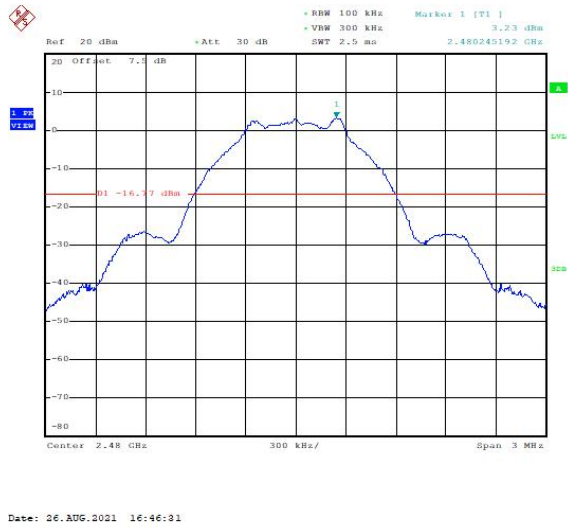

Conducted spurious emission: Ch39, 30MHz~26GHz

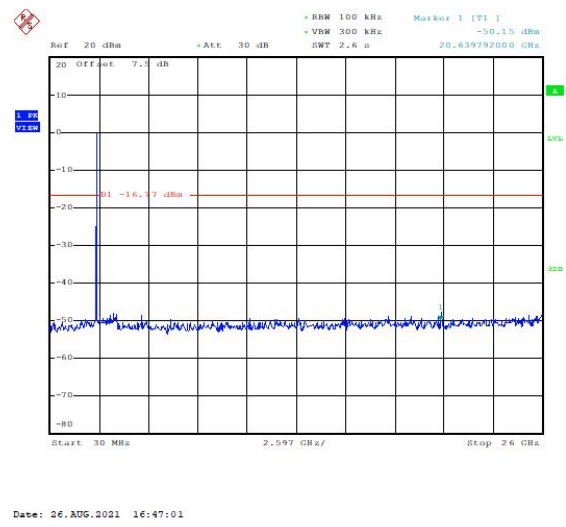

2M

Conducted spurious emission: Ch0, 2402MHz

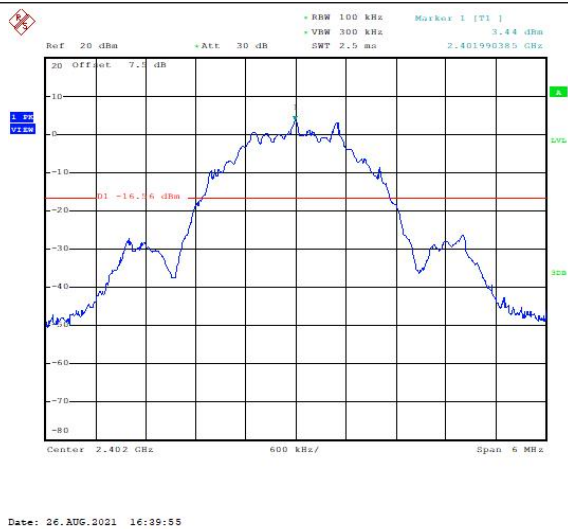

Conducted spurious emission: Ch0, 30MHz~26GHz

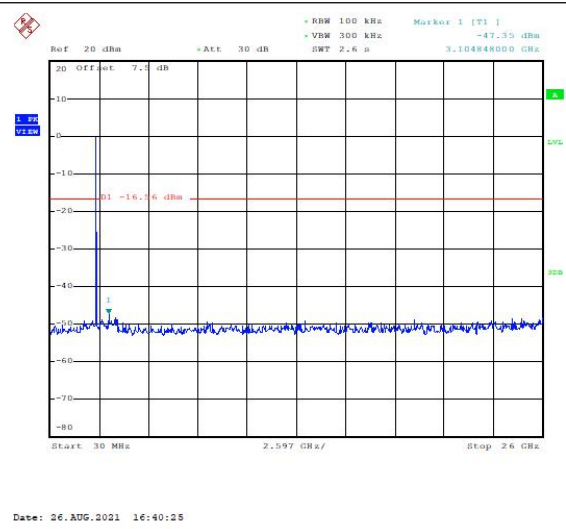

Conducted spurious emission: Ch19, 2441MHz

Conducted spurious emission: Ch19,
30MHz~26GHz

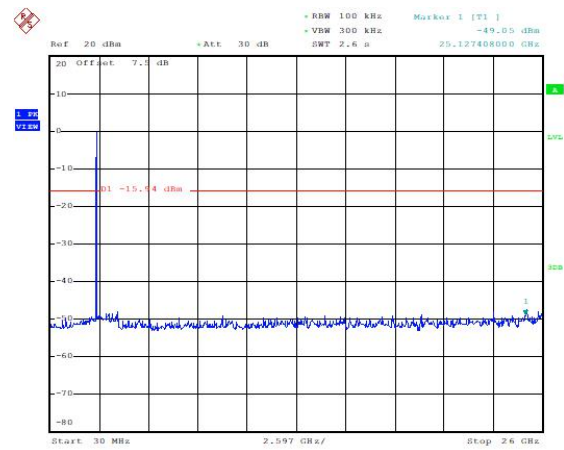
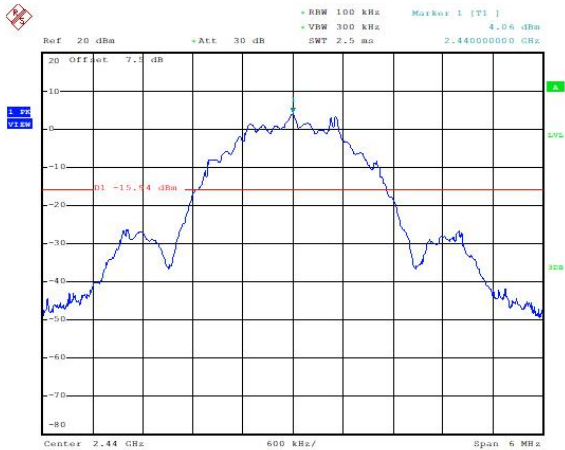

Date: 26.AUG.2021 16:41:02

Date: 26.AUG.2021 16:41:04

Conducted spurious emission: Ch39, 2480MHz

Conducted spurious emission: Ch39,
30MHz~26GHz

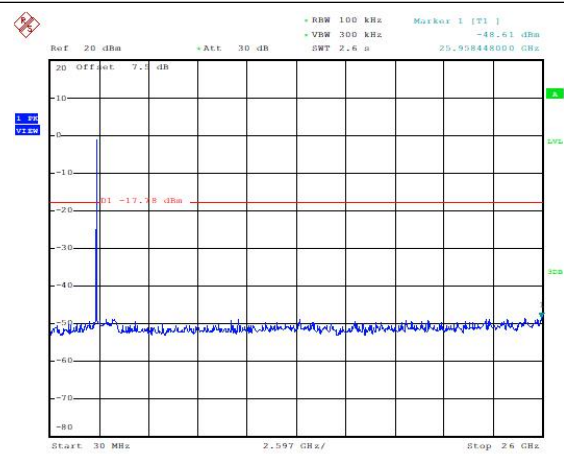
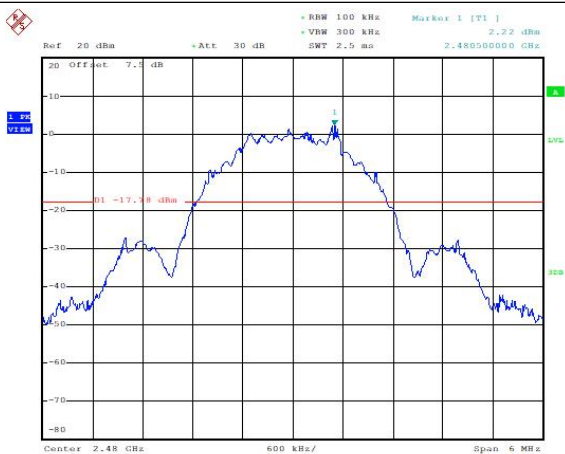

Date: 26.AUG.2021 16:41:56

Date: 26.AUG.2021 16:42:27

6.7. Radiated Emission

6.7.1. Measurement Limit

Standard	Limit
FCC 47 Part 15.247(d), 15.205(a), 15.209(a)	20dB below peak output power
RSS-Gen 8.9, 8.10	20dB below peak output power

In addition, radiated emissions which fall in the restricted bands, as defined in 15.205(a), must also comply with the radiated emission limits specified in 15.209(a) (see 15.205(c)).

Limit in restricted band

Frequency of emission	Field strength (uV/m)	Field strength (dBuV/m)
30~88	100	40
88~216	150	43.5
216~960	200	46
Above 960	500	54

6.7.2. Test Method

Portable, small, lightweight, or modular devices that may be handheld, worn on the body, or placed on a table during operation shall be positioned on a non-conducting platform, the top of which is 80 cm above the reference ground plane. The preferred area occupied by the EUT arrangement is 1 m by 1.5 m, but it may be larger or smaller to accommodate various sized EUTs. For testing purposes, ceiling- and wall-mounted devices also shall be positioned on a tabletop (see also ANSI C63.10-2013 section 6.3.4 and 6.3.5). In making any tests involving handheld, body-worn, or ceiling-mounted equipment, it is essential to recognize that the measured levels may be dependent on the orientation (attitude) of the three orthogonal axes of the EUT. Thus, exploratory tests as specified in 8.3.1 shall be carried out for various axes orientations to determine the attitude having maximum or near-maximum emission level. The EUT was placed on a non-conductive table. The measurement antenna was placed at a distance of 3 meters from the EUT. During the tests, the antenna height and the EUT azimuth were varied in order to identify the maximum level of emissions from the EUT. This maximization process was repeated with the EUT positioned in each of its three orthogonal orientations.

Frequency of emission (MHz)	RBW/VBW	Sweep Time (s)
30~1000	100KHz/300KHz	5
1000~4000	1MHz/3MHz	15
4000~18000	1MHz/3MHz	40
18000~26500	1MHz/3MHz	20

6.7.3. Test Setup

Below 1GHz Test Setup

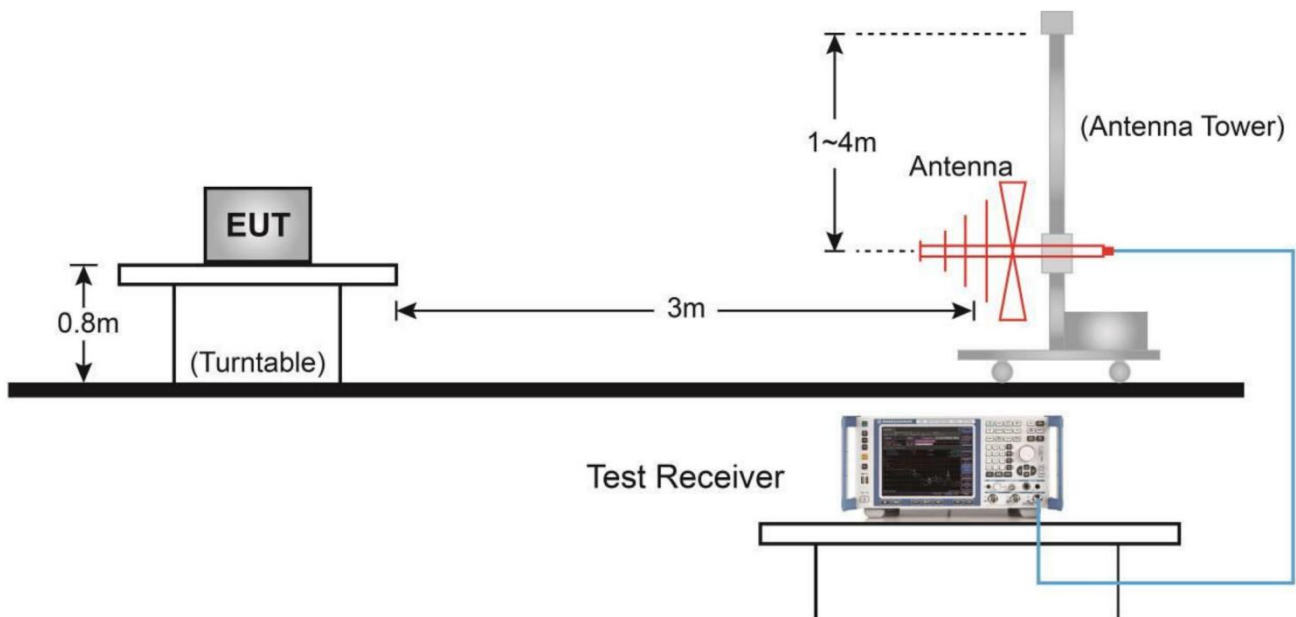

Above 1GHz Test Setup

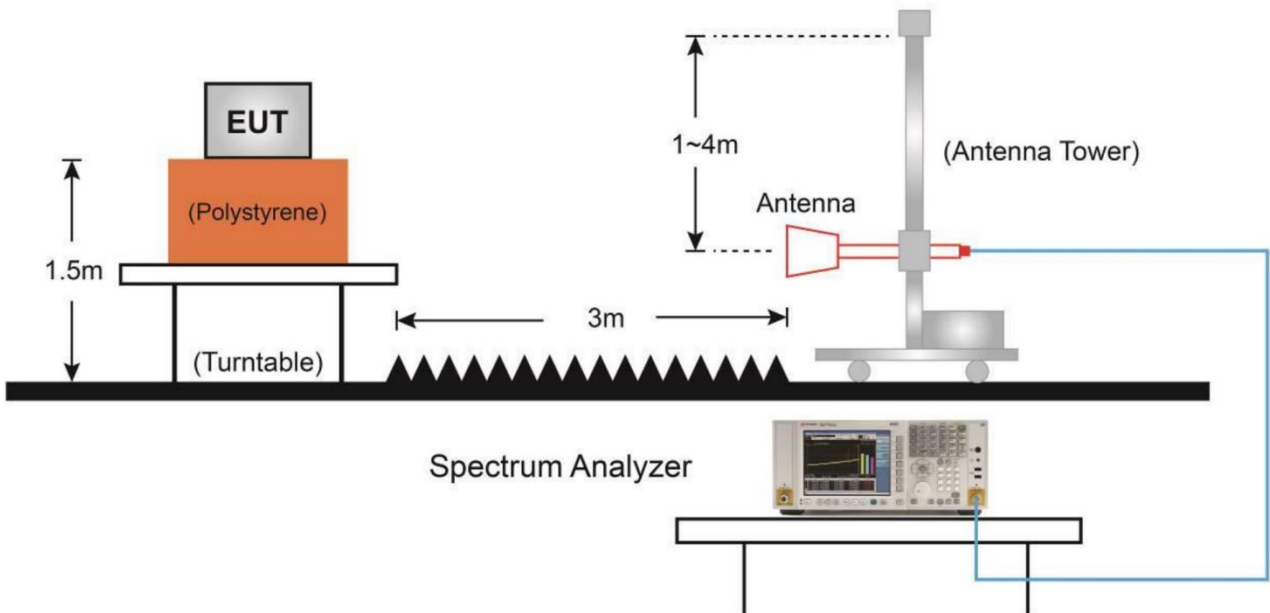

Measurement Results:

A “reference path loss” is established and A_{Rpi} is the attenuation of “reference path loss”, and including the gain of receive antenna, the gain of the preamplifier, the cable loss.

The measurement results are obtained as described below:

$$A_{Rpi} = \text{Cable loss} + \text{Antenna Factor} - \text{Preamplifier gain}$$

$$\text{Result} = P_{\text{Mea}} + A_{Rpi}$$

Mainly Supply

1M

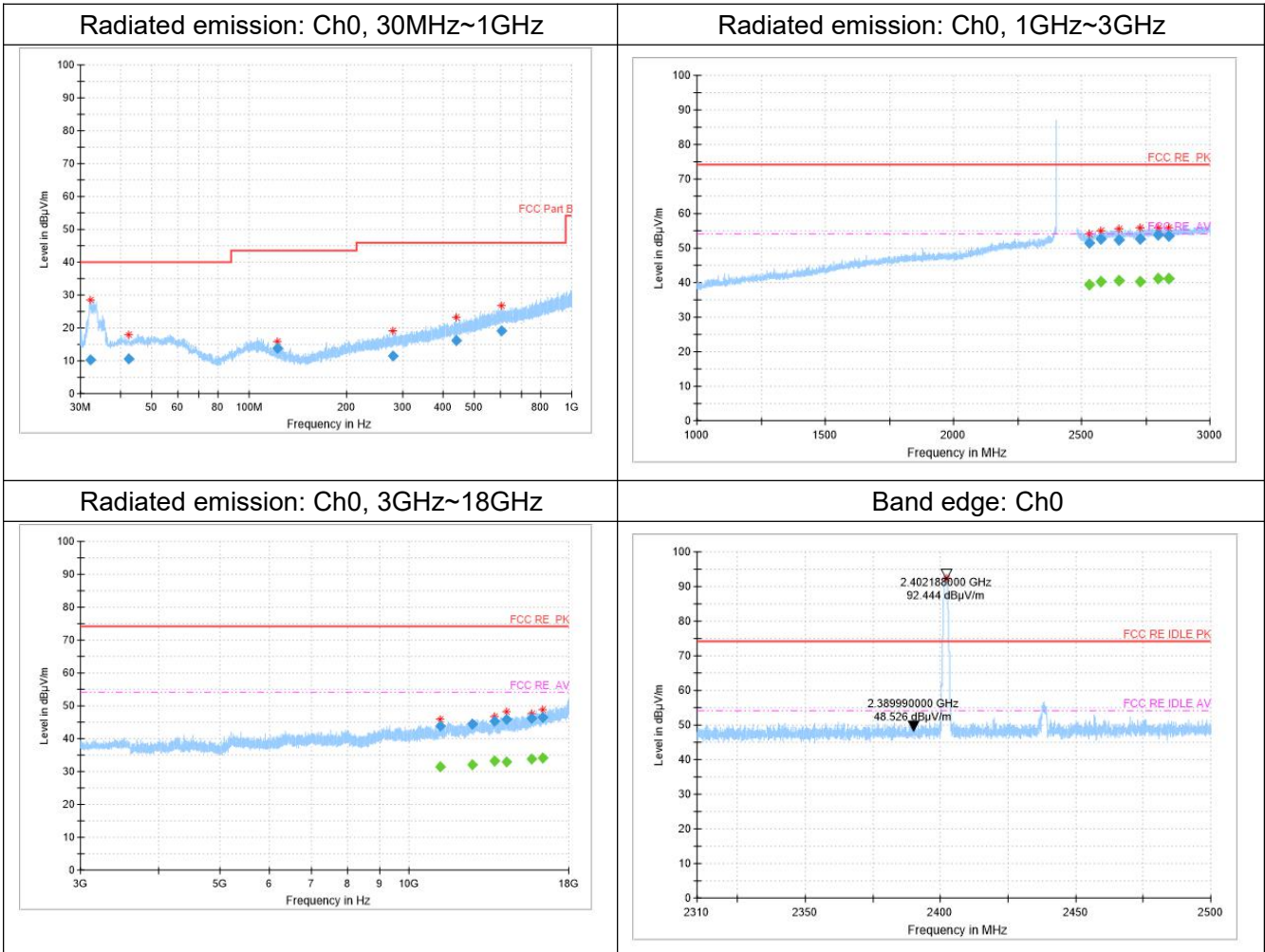

Radiated emission: Ch39, 30MHz~1GHz

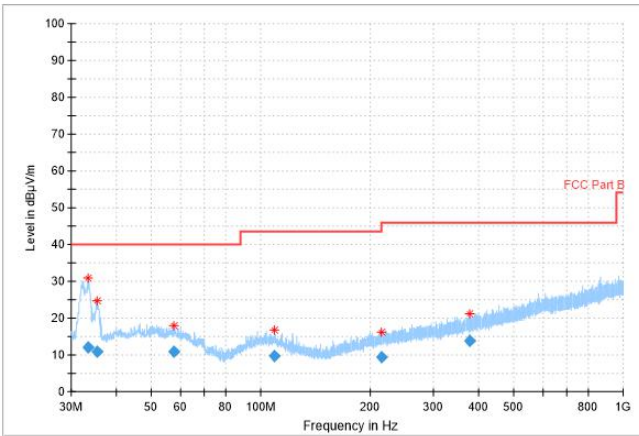

Radiated emission: Ch39, 1GHz~3GHz

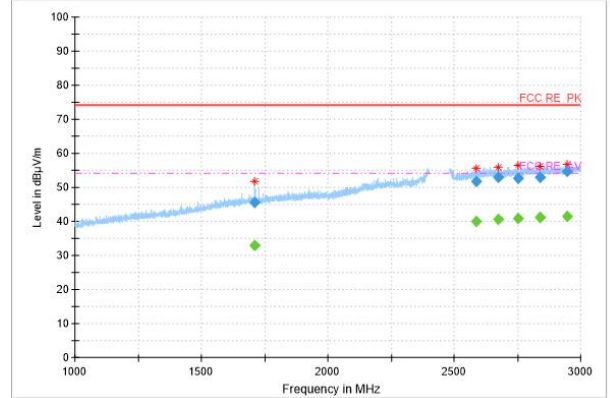

Radiated emission: Ch39, 3GHz~18GHz

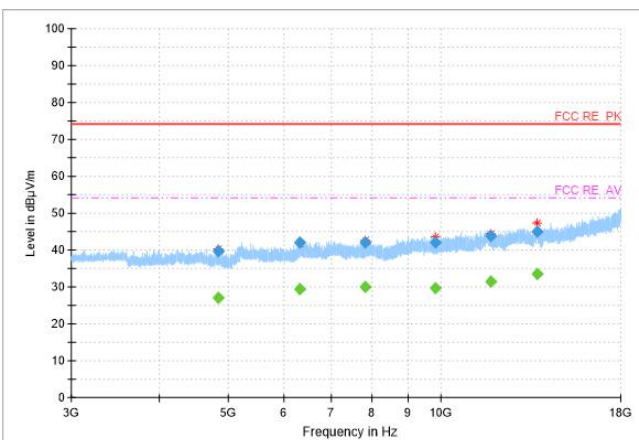

Bandedge:Ch39

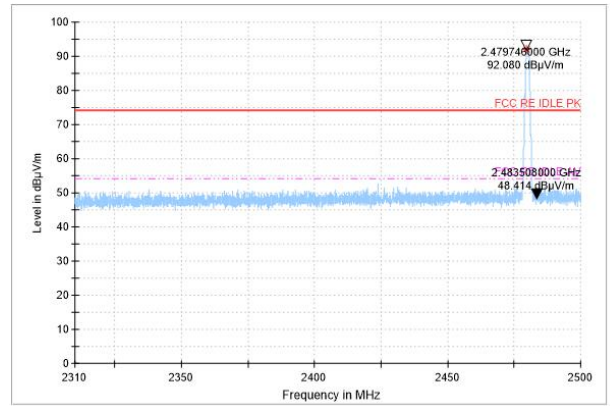

ALL Channel 18GHz~26GHz

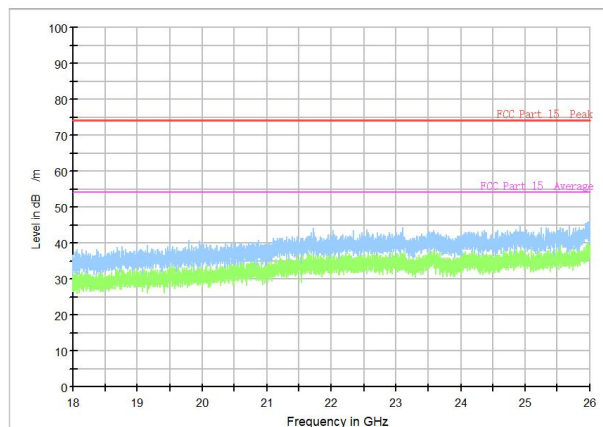

/

/

2M

Radiated emission: Ch0, 30MHz~1GHz

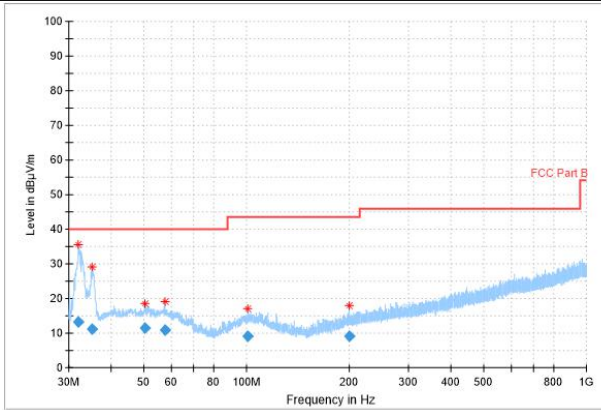

Radiated emission: Ch0, 1GHz~3GHz

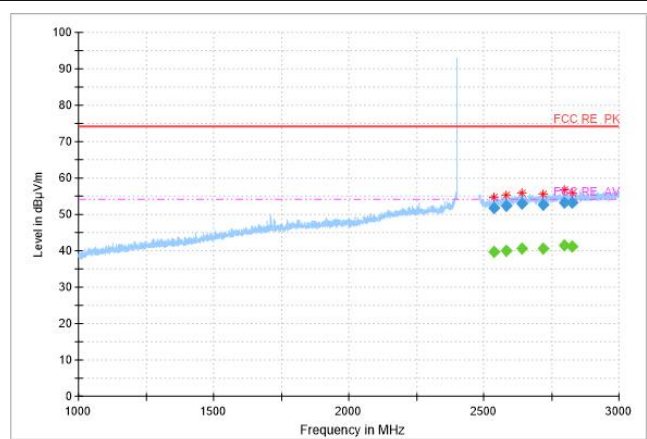

Radiated emission: Ch0, 3GHz~18GHz

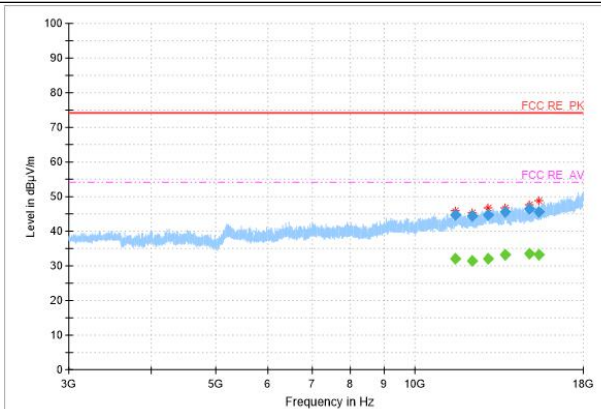

Band edge: Ch0

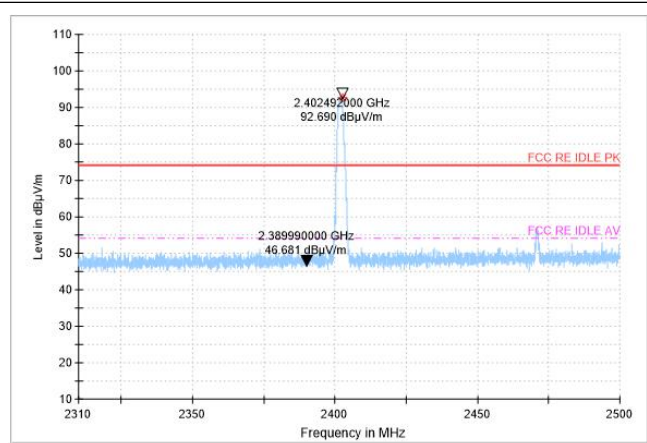

Radiated emission: Ch39, 30MHz~1GHz

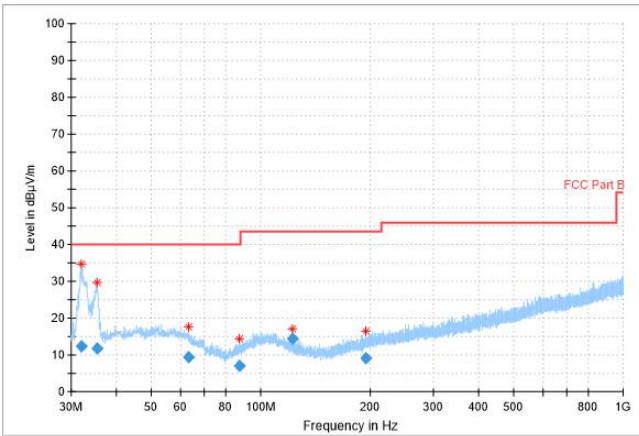

Radiated emission: Ch39, 1GHz~3GHz

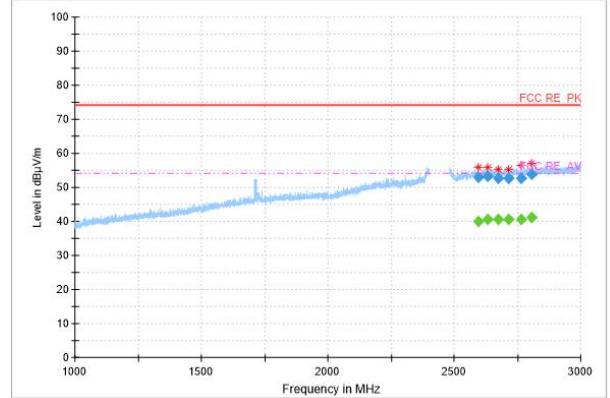

Radiated emission: Ch39, 3GHz~18GHz

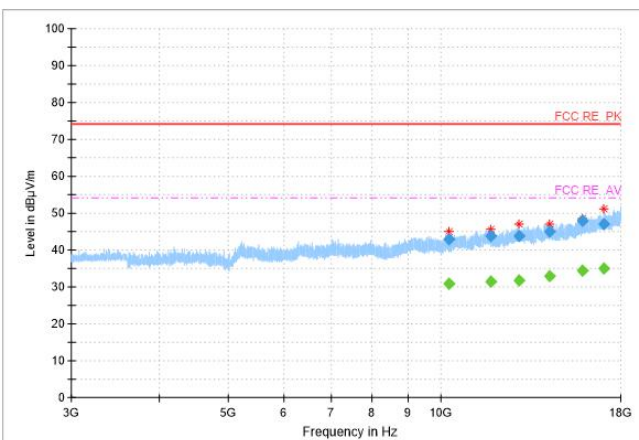

Bandedge:Ch39

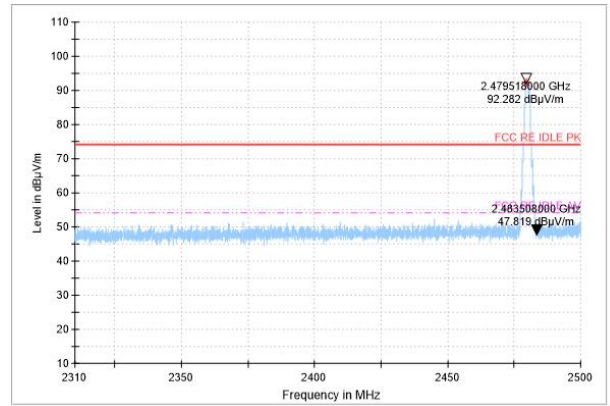

ALL Channel 18GHz~26GHz

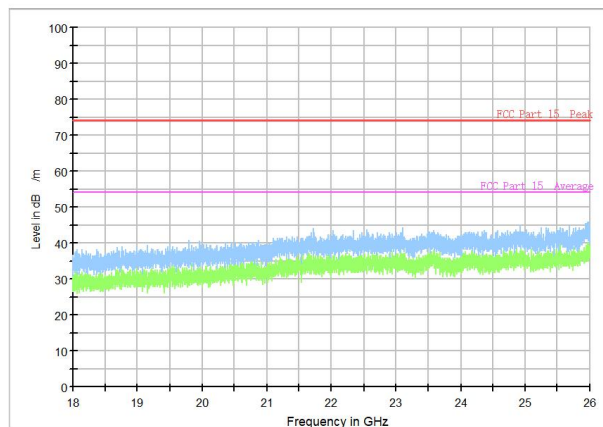

/

/



Mainly Supply

1M

Ch0 30MHz-1GHz

Frequency(MHz)	Result(dBuV/m)	ARpl (dB)	PMea(dBuV/m)	Polarity
32.2	10.44	-14.3	24.74	V
42.3	10.57	-12.6	23.17	V
122.7	13.9	-15.3	29.2	V
279.4	11.49	-10.9	22.39	H
437.3	16.07	-7.7	23.77	H
605.1	19.08	-3.3	22.38	H

Ch0 1GHz-3GHz

Frequency(MHz)	Result(dBuV/m)	ARpl (dB)	PMea(dBuV/m)	Polarity
2527.0	51.44	14.6	36.84	V
2574.1	52.77	15.3	37.47	V
2646.0	52.42	15.9	36.52	H
2725.3	52.65	16.1	36.55	H
2797.0	53.84	16.6	37.24	H
2837.7	53.5	16.6	36.9	H

Ch0 3GHz-18GHz

Frequency(MHz)	Result(dBuV/m)	ARpl (dB)	PMea(dBuV/m)	Polarity
11231.0	43.96	1.7	42.26	H
12630.7	44.3	2.8	41.5	V
13707.2	45.29	4.1	41.19	H
14309.8	45.76	5.4	40.36	H
15720.6	46.17	6.9	39.27	H
16340.3	46.41	8	38.41	V

Ch39 30MHz-1GHz

Frequency(MHz)	Result(dBuV/m)	ARpl (dB)	PMea(dBuV/m)	Polarity
33.4	12.06	-14.2	26.26	V
35.3	10.84	-14	24.84	V
57.6	11	-12.2	23.2	H
109.3	9.63	-13.2	22.83	V
214.9	9.54	-12.9	22.44	V
378.1	13.83	-8.7	22.53	H

Ch39 1GHz-3GHz

Frequency(MHz)	Result(dBuV/m)	ARpl (dB)	PMea(dBuV/m)	Polarity
1711.3	45.68	7.8	37.88	V
2588.6	51.78	15.4	36.38	H
2671.8	52.96	15.9	37.06	H
2752.1	52.75	16.2	36.55	H
2839.1	52.93	16.6	36.33	H
2945.4	54.73	16.8	37.93	H

Ch39 1GHz-3GHz (Average)

Frequency(MHz)	Result(dBuV/m)	ARpl (dB)	PMea(dBuV/m)	Polarity
2945.4	41.48	16.8	24.68	H

Ch39 3GHz-18GHz

Frequency(MHz)	Result(dBuV/m)	ARpl (dB)	PMea(dBuV/m)	Polarity
4836.1	39.8	-4.7	44.5	H
6307.5	42.15	-2.4	44.55	V
7824.6	42.11	-1.8	43.91	H
9834.4	42.2	-0.4	42.6	V
11785.0	43.87	2	41.87	H
13689.7	45.14	4	41.14	V

2M

Ch0 30MHz-1GHz

Frequency(MHz)	Result(dBuV/m)	ARpl (dB)	PMea(dBuV/m)	Polarity
32.0	13.12	-14.3	27.42	V
35.2	11.32	-14	25.32	V
50.4	11.46	-11.9	23.36	H
57.6	11.01	-12.2	23.21	H
100.6	9.09	-13.3	22.39	H
200.5	9.14	-13.9	23.04	H

Ch0 1GHz-3GHz

Frequency(MHz)	Result(dBuV/m)	ARpl (dB)	PMea(dBuV/m)	Polarity
2539.1	51.9	14.9	37	V
2583.6	52.27	15.4	36.87	H
2640.0	53.08	15.8	37.28	V
2718.5	52.59	16	36.59	V
2796.6	53.09	16.6	36.49	V
2828.4	53.33	16.6	36.73	H

Ch0 3GHz-18GHz

Frequency(MHz)	Result(dBuV/m)	ARpl (dB)	PMea(dBuV/m)	Polarity
11512.0	44.72	2.3	42.42	V
12203.9	44.48	2	42.48	H
12913.9	44.69	3.3	41.39	V
13712.5	45.52	4.1	41.42	H
14906.1	46.49	5.8	40.69	H
15438.0	45.53	6.4	39.13	H

Ch39 30MHz-1GHz

Frequency(MHz)	Result(dBuV/m)	ARpl (dB)	PMea(dBuV/m)	Polarity
32.1	12.26	-14.3	26.56	V
35.4	11.77	-13.9	25.67	V
63.3	9.51	-13.5	23.01	H
87.4	7.11	-16.1	23.21	V
122.7	14.27	-15.3	29.57	V
195.2	9	-14.1	23.1	V



Ch39 1GHz-3GHz

Frequency(MHz)	Result(dBuV/m)	ARpl (dB)	PMea(dBuV/m)	Polarity
2596.9	52.86	15.5	37.36	H
2632.3	53.35	15.7	37.65	H
2672.4	52.51	15.9	36.61	H
2714.9	52.76	16	36.76	V
2764.6	52.56	16.3	36.26	H
2805.5	53.92	16.6	37.32	V

Ch39 3GHz-18GHz

Frequency(MHz)	Result(dBuV/m)	ARpl (dB)	PMea(dBuV/m)	Polarity
10260.1	42.96	0.1	42.86	V
11759.8	43.81	2	41.81	V
12927.7	43.95	3.4	40.55	V
14287.6	44.92	5.4	39.52	H
15869.4	47.86	7.6	40.26	H
17020.1	47.12	8.8	38.32	V

7. Test Equipment List

7.1. Conducted Test System

Item	Equipment Name	Type	Serial Number	Manufacturer	Cal. Date	Cal. interval
1	Vector Signal Analyzer	FSQ26	101091	R&S	2020-05-11	1 year
					2021-05-10	
2	DC Power Supply	ZUP60-14	LOC-220Z006 -0007	TDL-Lambda	2020-05-11	1 year
					2021-05-10	
3	Eagle Test Software	Eagle V3.1 FCC BT/WIFI	N/A	ECIT	N/A	N/A

7.2. Radiated Emission Test System

Item	Equipment Name	Type	Serial Number	Manufacturer	Cal. Date	Cal. interval
1	Universal Radio Communication Tester	CMU200	123123	R&S	2020-05-11	1 year
					2021-05-10	
2	EMI Test Receiver	ESU40	100307	R&S	2021-03-03	1 year
3	TRILOG Broadband Antenna	VULB9163	VULB9163-51 5	Schwarzbeck	2021-02-03	2 years
4	Double- ridged Waveguide Antenna	ETS-3117	00135890	ETS	2020-02-28	3 years
5	Universal Radio Communication Tester	CMW500	104178	R&S	2020-05-11	1 year
					2021-05-10	
6	EMI Test Software	EMC32 V 9.15.00	N/A	R&S	N/A	N/A

Anechoic chamber

Fully anechoic chamber by ETS.

Annex A: Measurement Uncertainty

Measurement uncertainty for all the testing in this report are within the limit specified in 3IN documents. The detailed measurement uncertainty is defined in 3IN documents.

Measurement Items	Range	Confidence Level	Calculated Uncertainty
Peak Output Power-Conducted	2402MHz-2480MHz	95%	0.544dB
Peak Power Spectral Density	2402MHz-2480MHz	95%	0.544dB
6dB Bandwidth	2402MHz-2480MHz	95%	62.04Hz
Frequency Band Edges-Conducted	2390MHz-2488.5MHz	95%	0.544dB
Conducted Emission	30MHz-2GHz	95%	0.90dB
Conducted Emission	2GHz-3.6GHz	95%	0.88dB
Conducted Emission	3.6GHz-8GHz	95%	0.96dB
Conducted Emission	8GHz-20GHz	95%	0.94dB
Conducted Emission	20GHz-22GHz	95%	0.88dB
Conducted Emission	22GHz-26GHz	95%	0.86dB
Transmitter Spurious Emission-Radiated	9KHz-30MHz	95%	5.66dB
Transmitter Spurious Emission-Radiated	30MHz-1000MHz	95%	4.98dB
Transmitter Spurious Emission-Radiated	1000MHz -18000MHz	95%	5.06dB
Transmitter Spurious Emission-Radiated	18000MHz -40000MHz	95%	5.20dB
AC Power line Conducted Emission	0.15MHz-30MHz	95%	3.66 dB

Annex B: Accreditation Certificate



Accredited Laboratory

A2LA has accredited

INDUSTRIAL INTERNET INNOVATION CENTER (SHANGHAI) CO., LTD.

Shanghai, People's Republic of China

for technical competence in the field of

Electrical Testing

This laboratory is accredited in accordance with the recognized International Standard ISO/IEC 17025:2017 General requirements for the competence of testing and calibration laboratories. This accreditation demonstrates technical competence for a defined scope and the operation of a laboratory quality management system (refer to joint ISO-ILAC-IAF Communiqué dated April 2017).



Presented this 12th day of April 2021.



Vice President, Accreditation Services
For the Accreditation Council
Certificate Number 3682.01
Valid to February 28, 2023

For the tests to which this accreditation applies, please refer to the laboratory's Electrical Scope of Accreditation.

*****END OF REPORT*****