



TEST REPORT

Report Number: C21T00097-EMC04-V01

Applicant	Shanghai Sunmi Technology Co.,Ltd.
Product Name	Handheld Wireless Terminal
Model Name	T8A10
Brand Name	SUNMI
FCC ID	2AH25T8A10
IC	22621-T8A10

Industrial Internet Innovation Center (Shanghai) Co., Ltd. tested the above equipment in accordance with the requirements in FCC CFR47 Part 2, FCC CFR47 Part 15C, ANSI C63.10-2013, RSS-Gen Issue 5, RSS-210 Issue 10.

Prepared by 李柳凯

Reviewed by 李五真

Approved by 李柳凯

Issue Date 2021-12-16

Industrial Internet Innovation Center (Shanghai) Co., Ltd.



NOTE

1. This report is invalid without the signature of the writer, reviewer and authorizer.
2. This report is invalid if altered.
3. For the benefit of clients, if you have any objection to the report, please inform the testing laboratory within 15 days from the date of receiving this report.
4. Samples in the test report are provided by the client. The test results are only applicable to the samples received by the laboratory. The source information of samples (such as sample sender, manufacturer, etc.) in the test report is provided by the client, and the laboratory is not responsible for its authenticity and the measurement accuracy.
5. The test report does not represent the identification of a product by a certification body or an authorized body.
6. This report is only valid as a whole, and no part of the report can be reproduced without the written approval of Industrial Internet Innovation Center (Shanghai) Co., Ltd.
7. Without the written permission of testing institutions and accreditation bodies, this report cannot be used in part or in whole for publicity or product introduction.
8. "N/A" is used in this report to indicate that it is not applicable or available.
9. Industrial Internet Innovation Center (Shanghai) Co., Ltd. assumes the legal responsibility for the report.
10. The measurement uncertainty is not taken into account when deciding conformity, and the results of measurement (or the average of measurement results) are directly used as the criterion for the stating conformity.

Test Laboratory:

Industrial Internet Innovation Center (Shanghai) Co., Ltd.
Add: Building 4, No. 766 Jingang Rd, Pudong, Shanghai, China
Tel: +86 21 68866880

Industrial Internet Innovation Center (Shanghai) Co., Ltd.
Add: Building 4, No. 766 Jingang Rd, Pudong, Shanghai, China
Tel: +86 21 68866880

Page Number: 2 of 29
Report No.: C21T00097-EMC04-V01



Revision Version

Report Number	Revision	Date	Memo
C21T00097-EMC04-V00	00	2021-12-09	Initial creation of test report
C21T00097-EMC04-V01	01	2021-12-16	Updated chapter 5.1 and 6.2



CONTENTS

1. TEST LABORATORY	6
1.1. TESTING LOCATION	6
1.2. TESTING ENVIRONMENT	6
1.3. PROJECT INFORMATION	6
2. CLIENT INFORMATION	7
2.1. APPLICANT INFORMATION	7
2.2. MANUFACTURER INFORMATION	7
3. EQUIPMENT UNDER TEST (EUT) AND ANCILLARY EQUIPMENT (AE)	8
3.1. ABOUT EUT	8
3.2. INTERNAL IDENTIFICATION OF EUT USED DURING THE TEST	8
3.3. INTERNAL IDENTIFICATION OF AE USED DURING THE TEST	8
4. REFERENCE DOCUMENTS	9
4.1. REFERENCE DOCUMENTS FOR TESTING	9
5. TEST SUMMARY	10
5.1. SUMMARY OF TEST RESULTS	10
5.2. STATEMENTS	10
5.3. DECISION OF FINAL TEST MODE	11
5.4. EUT CONNECTION DIAGRAM OF TEST SYSTEM	12
6. MEASUREMENT RESULTS	13
6.1 20DB BANDWIDTH	13
6.2 FREQUENCY STABILITY	15
6.3 RADIATED EMISSIONS	17
6.3.1 ELECTRIC FIELD STRENGTH OF FUNDAMENTAL EMISSIONS	17
6.3.2 ELECTRIC FIELD RADIATED EMISSIONS (BELOW 30MHZ)	19



6.3.3 ELECTRIC FIELD RADIATED EMISSIONS (ABOVE 30MHZ)	21
6.4 CONDUCTED EMISSIONS	23
6.5 OCCUPIED BANDWIDTH	25
7. TEST EQUIPMENT LIST	27
ANNEX A: MEASUREMENT UNCERTAIN	28
ANNEX B: ACCREDITATION CERTIFICATE	29

1. Test Laboratory

1.1. Testing Location

Primary Lab:

Company Name	Industrial Internet Innovation Center (Shanghai) Co., Ltd.
Address	Building 4, No. 766 Jingang Rd, Pudong, Shanghai, China
FCC Registration No.	958356
FCC Designation No.	CN1177
IC designation No.	CN0067

1.2. Testing Environment

Normal Temperature	15°C~35°C
Relative Humidity	30%RH~60%RH
Supply Voltage	120V/60Hz

1.3. Project Information

Project Leader	Wang Wenwen
Testing Start Date	2021-10-26
Testing End Date	2021-10-26



2. Client Information

2.1. Applicant Information

Company Name	Shanghai Sunmi Technology Co.,Ltd.
Address	Room 505, KIC Plaza, No.388 Song Hu Road, Yang Pu District, Shanghai, China
Telephone	+86 18501703215

2.2. Manufacturer Information

Company Name	Shanghai Sunmi Technology Co.,Ltd.
Address	Room 505, KIC Plaza, No.388 Song Hu Road, Yang Pu District, Shanghai, China
Telephone	+86 18501703215

3. Equipment under Test (EUT) and Ancillary Equipment (AE)

3.1. About EUT

Product Name	Handheld Wireless Terminal
Model name	T8A10
Supported Radio Technology and Bands	GSM850/GSM900/GSM1800/GSM1900 WCDMA Band I /Band II /Band IV /Band V /Band VIII LTE 1/2/3/4/5/7/12/13/17/18/19/25/26/28/38/40/41/66/71 BT5.0 WLAN 802.11b,g,n WLAN 802.11a,n,ac NFC GPS GLONASS Galileo BDS
Hardware Version	V4
Software Version	V025

Note: Photographs of EUT are shown in ANNEX B of this test report.

3.2. Internal Identification of EUT used during the test

EUT ID*	SN or IMEI	HW Version	SW Version	Date of Receipt
N08	866584051015747	V4	V025	2021/08/04

*EUT ID: is internally used to identify the test sample in the lab.

3.3. Internal Identification of AE used during the test

AE ID*	Description	Model	SN/Remark
CA01	Adapter	CK18W02U	N/A
UA02	USB Cable	USB A TO C+PTC 1.5M	N/A
BA10	Battery	JKRA	N/A
AE1	Type A Card	N/A	N/A

*AE ID: is internally used to identify the test sample in the lab.

*The AE is provided by the lab.

4. Reference Documents

4.1. Reference Documents for testing

The following documents listed in this section are referred for testing.

Reference	Title	Version
FCC CFR47 Part 2	Frequency allocations and radio treaty matters; general rules and regulations	2020/10/01
FCC CFR47 Part 15C	Radio Frequency Devices-Intentional Radiators	2020/10/01
ANSI C63.10	American National Standard of Procedures for Compliance Testing of Unlicensed Wireless Devices	2013
RSS-210	License-Exempt Radio Apparatus: Category I Equipment	Issue 10
RSS-Gen	General Requirements for Compliance of Radio Apparatus	Issue 5

5. Test Summary

5.1. Summary of Test Results

Items	Test List	Sub-clause of FCC Standard	Sub-clause of IC Standard	Verdict
1	20 dB bandwidth	2.1049	RSS-Gen 6.7	Pass
2	Frequency Stability	15.225(e)	RSS-210 B.6.b	Pass
3	Radiated Emissions	15.225 (a) (b) (c) (d) and 15.209	RSS-210 B.6.a (i , ii , iii, iv)	Pass
4	Conducted Emissions	15.207	RSS-Gen 8.8	Pass
5	Occupied bandwidth	N/A	RSS-Gen 6.7	Pass

5.2. Statements

The T8A10, manufactured by Shanghai Sunmi Technology Co.,Ltd. is a new product for testing.

Industrial Internet Innovation Center (Shanghai) Co., Ltd. only performed test cases which identified with Pass/Fail/Inc result in section 5.1.

Industrial Internet Innovation Center (Shanghai) Co., Ltd. has verified that the compliance of the tested device specified in section 3 of this test report is successfully evaluated according to the procedure and test methods as defined in type certification requirement listed in section 4 of this test report.

5.3. Decision of final test mode

The EUT was tested together with the above additional components, and a configuration, which produced the worst emission levels, was selected and recorded in this report.

The test configuration modes are as the following:

Test Item	Test setup and operating modes
20 dB bandwidth	Mode 1: TX mode <Figure 1>
Frequency Stability	Mode 1: TX mode <Figure 1>
Radiated Emissions	Mode 1: TX mode <Figure 1>
Conducted Emissions	Mode 2: TX mode+CA01+UA02+BA10 <Figure 2>
Occupied bandwidth	Mode 1: TX mode <Figure 1>
Remark: Enter working mode according to NFC transmission command. The EUT will transmit the NFC command continuously during the test, and will read the information from the Type A Card continuously.	

5.4. EUT Connection Diagram of Test System

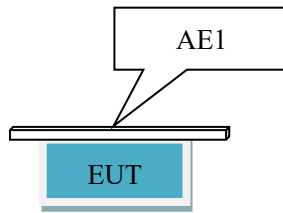

<Figure 1> Mode 1

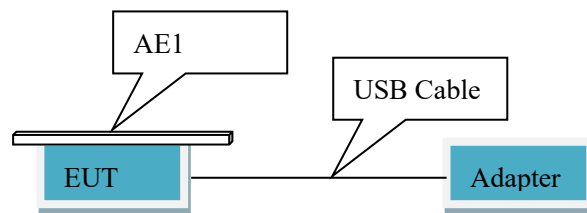

<Figure 2> Mode 2

6. Measurement Results

6.1 20dB Bandwidth

Reference

See Clause 6.9 of ANSI C63.10-2013

Measurement Methods

The transmitter output signal was picked up by coil antenna to the spectrum analyzer.

The transmitter output signal was picked up by coil antenna connected to the spectrum analyzer.

The bandwidth of the center frequency was measured with 140Hz RBW, 420Hz VBW and 14kHz span.

Test Setup

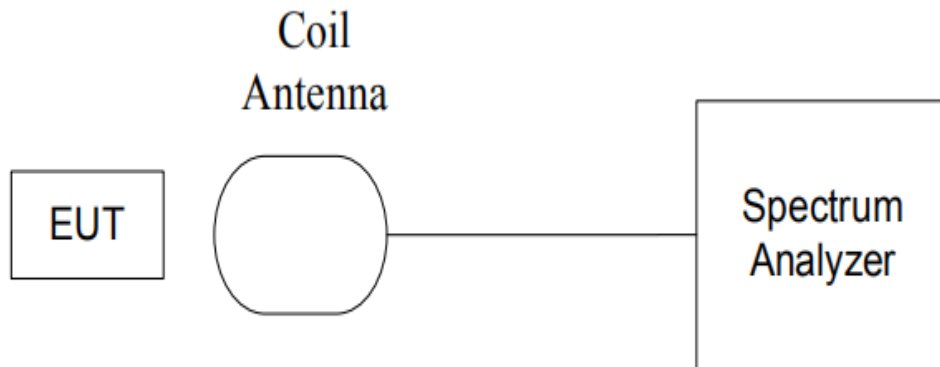

EUT Operating Mode and Test Conditions

The measurement of EUT is carried out under the transmit state of NFC and without modulation.

EUT had been not connected to a travel adapter.

During the measurements, the ambient temperature is in the range of 15~25°C.

Limits

The 20dB bandwidth shall be less than 80% of the permitted frequency band. For 13.56MHz NFC, the permitted frequency band is 14kHz, so the limit is 11.2kHz.

Test Results:

Carrier frequency (MHz)	20dB Bandwidth (kHz)	Conclusion
13.56	0.583	Pass

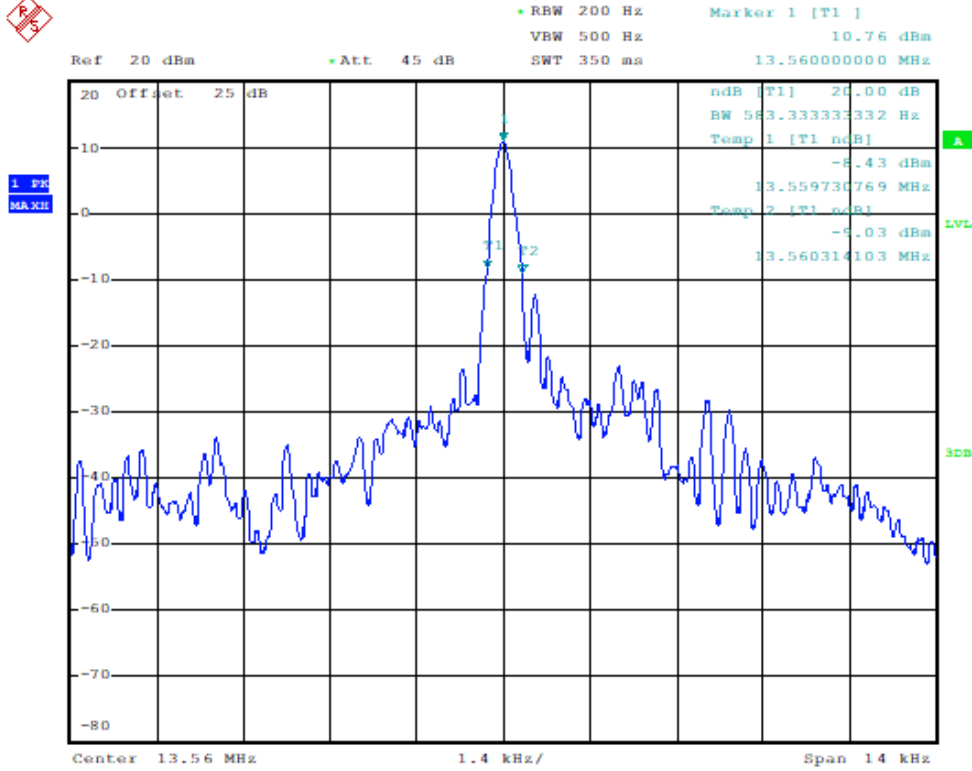

Date: 26.OCT.2021 15:05:42

6.2 Frequency Stability

Reference

See Clause 6.8 of ANSI C63.10-2013

Measurement Methods

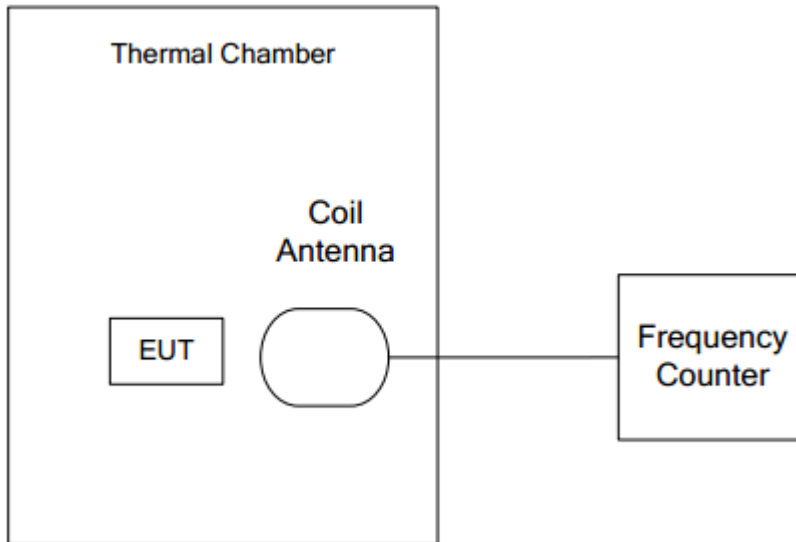

The transmitter output signal was picked up by the coil antenna connected to the frequency counter. The center frequency was measured with 30Hz RBW and 1kHz span.

During the test, the EUT was placed in a thermal chamber until thermal balance and lasting appropriate time.

EUT Operating Mode and Test Conditions

The measurement of EUT is carried out under the transmit state of without modulation, EUT1 had been not connected to a travel adapter.

Operation Temperature: $T_{min}=-20^{\circ}\text{C}$, $T_{nom}=25^{\circ}\text{C}$, and $T_{max}=55^{\circ}\text{C}$

Operation Voltage: $V_{min}=3.45\text{V}$, $V_{max}=4.45\text{V}$, and $T_{nom}=3.87\text{V}$.

Limits

FCC: The frequency tolerance of the carrier signal shall be maintained within $\pm 0.01\%$ of the operating frequency.

IC: The carrier frequency stability shall not exceed ± 100 ppm.

Test Results

Temperature	Voltage	Frequency Error (MHz)			
		Startup	2Min Later	5Min Later	10Min Later
T_{min}	V_{nom}	13.560000	13.560024	13.560019	13.560022
T_{max}	V_{nom}	13.560136	13.560116	13.560138	13.560141
T_{nom}	V_{nom}	13.560168	13.560137	13.560171	13.560170
T_{nom}	V_{min}	13.560127	13.560122	13.560123	13.560124



Tnom	Vmax	13.560139	13.560135	13.560133	13.560132
------	------	-----------	-----------	-----------	-----------

Temperature	Voltage	Frequency Error (%)			
		Startup	2Min Later	5Min Later	10Min Later
Tmin	Vnom	0.000	0.001	0.001	0.001
Tmax	Vnom	0.001	0.001	0.001	0.001
Tnom	Vnom	0.001	0.001	0.001	0.001
Tnom	Vmin	0.001	0.001	0.001	0.001
Tnom	Vmax	0.001	0.001	0.001	0.001

6.3 Radiated Emissions

6.3.1 Electric Field Strength of Fundamental Emissions

Reference

See Clause 6.4 of ANSI C63.10-2013

Method of Measurement

The test set-up was made in accordance to the general provisions of ANSI C63.10-2013. The transmitter carrier output levels (E-Field) from the EUT are measured in a semi-anechoic chamber. The EUT is placed on a non-conductive stand of 80cm high, and at a measurement distance of 3m from the receiving antenna. The center of the receiving antenna is 1 meter above the ground. The E-field is measured with a shielded loop antenna connected to a measurement receiver. Detected E-field was maximized by rotating the EUT through 360° and adjusting the receiving antenna polarizations. Both horizontal and vertical polarizations of the antenna were set during the measurement. The maximization processes were repeated with the EUT positioned respectively in its three orthogonal axes. The measurements were performed with the peak detector and if required, the quasi-peak detector.

The measurement bandwidth:

Frequency (MHz)	RBW / VBW
12.56-14.56	10 / 30kHz

The E-field measured at 3m is calculated as:

$$\text{E-field (dBuV/m)} = \text{Rx (dBuV)} + \text{Cable Loss (dB)} + \text{AF@3m (dB/m)}$$

Test Setup

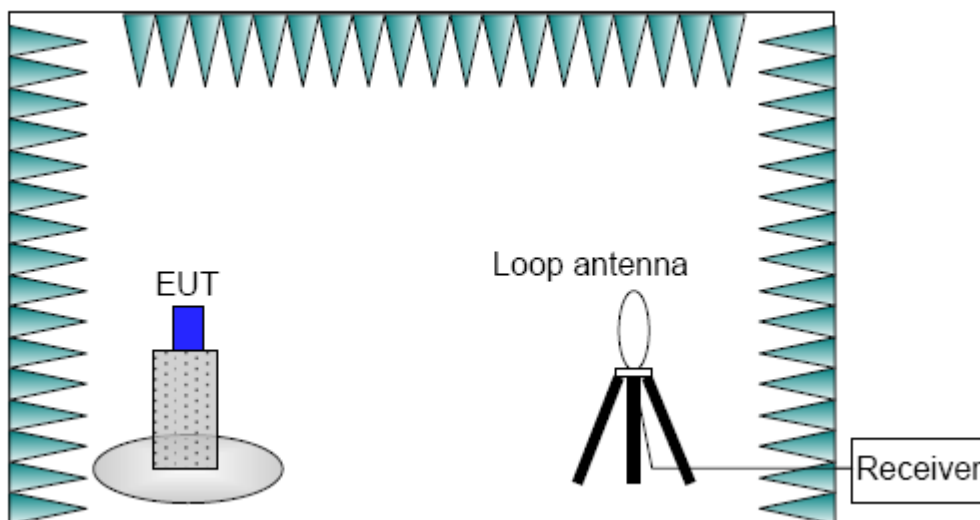

Limits

Clause 15.225(a) the field strength of any emissions within the band 13.553-13.567 MHz shall not exceed 15,848 microvolts/meter at 30 meters.

Clause 15.225(b) within the bands 13.410-13.553 MHz and 13.567-13.710 MHz, the field strength of any emissions shall not exceed 334 microvolts/meter at 30 meters.

Clause 15.225(c) within the bands 13.110-13.410 MHz and 13.710-14.010 MHz the field strength of any emissions shall not exceed 106 microvolts/meter at 30 meters.

Frequency Range (MHz)	E-field Strength Limit @30m (uV/m)	E-field Strength Limit @3m (dBuV/m)
13.560 ± 0.007	+15,848	124
13.410 to 13.553 13.567 to 13.710	+334	90
13.110 to 13.410 13.710 to 14.010	+106	81

Note: Where the limits have been defined at one distance, and a signal level measured at another, the limits have been extrapolated using the following formula:

$$\text{Extrapolation (dB)} = 40 \log_{10}(\text{Measurement Distance} / \text{Specification Distance})$$

Measurement Results

Measurement results of normal conditions see Figure 1 for different set-ups of EUT. The result displayed take into account applicable antenna factors and cable losses.

Note: dBμV/m stands for dBuV/m

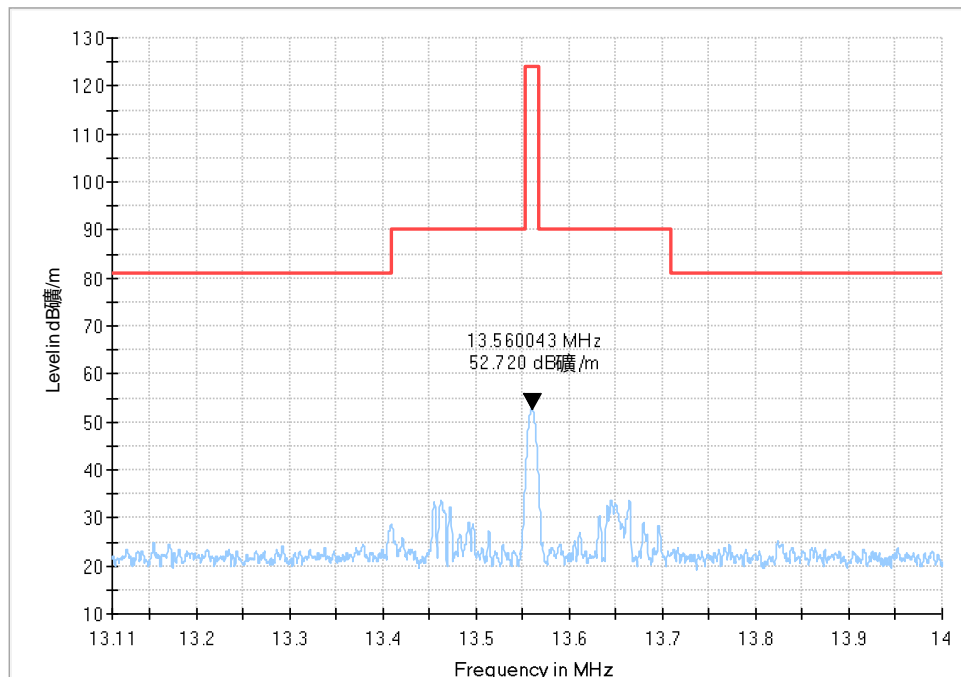

Figure 1 TX mode

6.3.2 Electric Field Radiated Emissions (Below 30MHz)

Reference

See Clause 6.4 of ANSI C63.10-2013

Method of Measurement

The electric field radiated emissions from the EUT are measured in a semi-anechoic chamber. The EUT is placed on a non-conductive stand of 80cm high, and at a measurement distance of 3m from the receiving antenna. The center of the receiving antenna is 1 meter above the ground. The E-field is measured with a shielded loop antenna connected to a measurement receiver. Detected E-field was maximized by rotating the EUT through 360° and adjusting the receiving antenna polarizations. Both horizontal and vertical polarizations of the antenna were set during the measurement. The maximization processes were repeated with the EUT positioned respectively in its three orthogonal axes. The measurements were performed with the peak detector and if required, the quasi-peak detector.

The measurement bandwidth:

Frequency (MHz)	RBW / VBW
0.009-30	10 / 30kHz

The E-field measured at 3m is calculated as:

$$E\text{-field (dBuV/m)} = Rx \text{ (dBuV)} + \text{Cable Loss (dB)} + AF@3m \text{ (dB/m)}$$

Test Setup

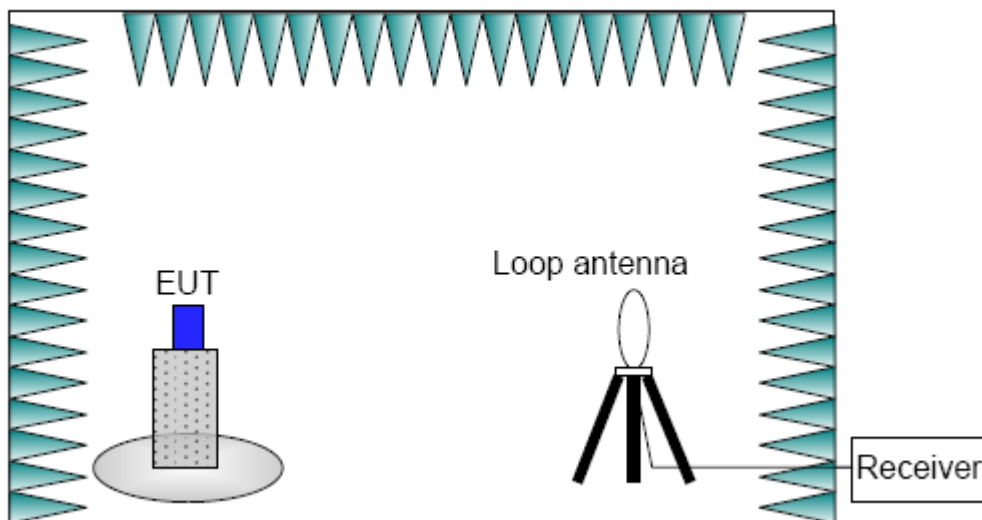

Limits

Frequency Range (MHz)	E-field Strength Limit @30m (mV/m)	E-field Strength Limit @3m (dBuV/m)
0.009-0490	2400/F (kHz)	129-94
0.490-1.705	24000/F (kHz)	74-63
1.705-30	30	70

Note: Where the limits have been defined at one distance, and a signal level measured at another, the limits have been extrapolated using the following formula:
 Extrapolation (dB) = $40\log_{10}(\text{Measurement Distance} / \text{Specification Distance})$
 dBuA/m=dBuV/m / 120π

Measurement Results

Measurement results of normal conditions see Figure 2 for different set-ups of EUT. The result displayed take into account applicable antenna factors and cable losses
 dBuV/m and dBuA/m can be converted to each other, so the test data of dBuV/m are reflected in the report

Note: $\text{dB}\mu\text{V}/\text{m}$ stands for dBuV/m

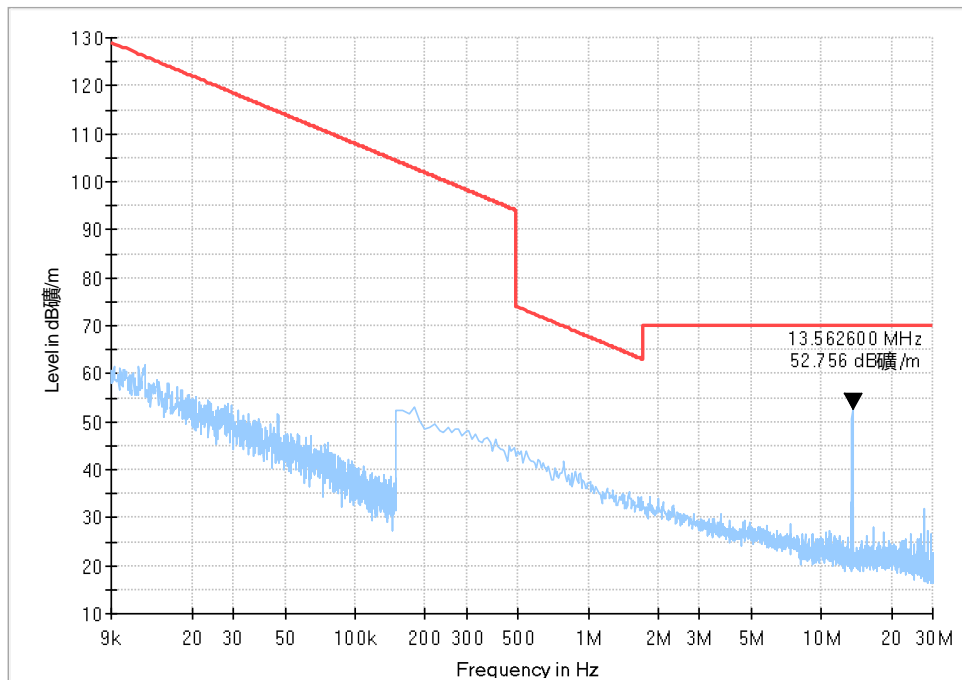

Figure 2 TX mode (9kHz-30MHz)

6.3.3 Electric Field Radiated Emissions (Above 30MHz)

Reference

See Clause 6.5 of ANSI C63.10-2013

Method of Measurement

The electric field radiated emissions from the EUT are measured in a semi-anechoic chamber. The EUT is placed on a non-conductive stand of 80cm high, and at a measurement distance of 3m from the receiving antenna. The table was rotated 360 degree and the received antenna mounted on a variable-height antenna tower was varied from 1m to 4m to find the maximum value of the field strength. Both horizontal and vertical polarizations of the antenna were set during the measurement. The data of cable loss and antenna factor has been calibrated in full testing frequency range before the testing. The measurements were performed with the peak detector and if required, the quasi-peak detector.

The measurement bandwidth:

Frequency (MHz)	RBW / VBW
30-1000	120 kHz / 300kHz

Test Setup

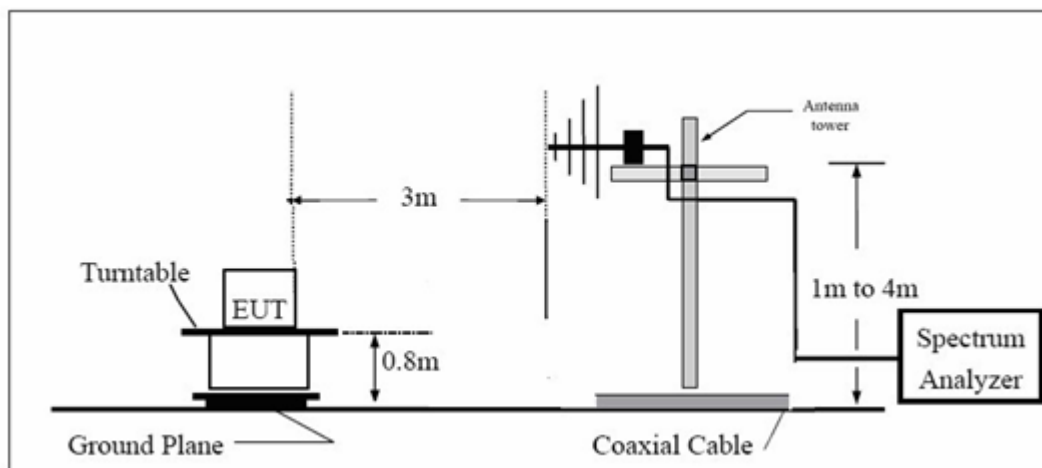

Limits

Frequency Range (MHz)	E-field Strength Limit @3m (mV/m)	E-field Strength Limit @3m (dBuV/m)
30-88	100	40
88-216	150	43.5
216-960	200	46
960-1000	500	54

Measurement Results

Measurement results of normal conditions see Figure 3 for different set-ups of EUT. The result displayed take into account applicable antenna factors and cable losses

QP detection is used in radiated emissions test, and the Duty Cycle of NFC main frequency signal is 100%.

Note: dB μ V/m stands for dBuV/m

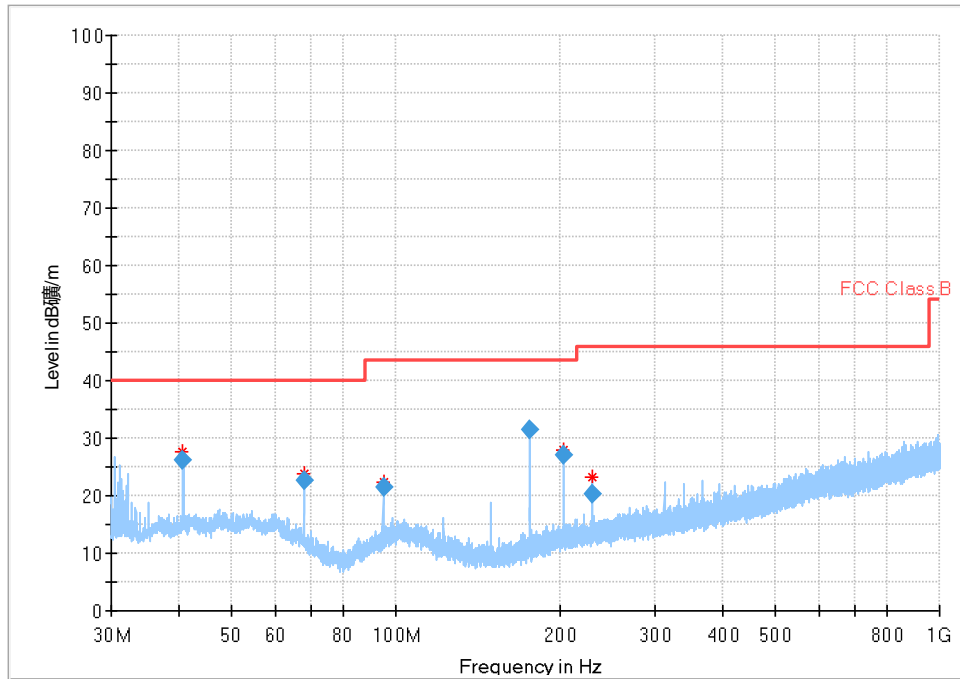

Figure 3 TX mode (30MHz-1000MHz)

Frequency (MHz)	QuasiPeak (dB μ V/m)	Limit (dB μ V/m)	Margin (dB)	Meas. Time (ms)	Bandwidth (kHz)	Height (cm)	Pol	Azimuth h (deg)	Corr. (dB)
40.664696	26.18	40.00	13.82	1000.0	120.000	225.0	H	158.0	-12.8
67.809555	22.67	40.00	17.33	1000.0	120.000	225.0	H	65.0	-15.2
94.919421	21.55	43.50	21.95	1000.0	120.000	179.0	H	62.0	-14.3
176.283472	31.40	43.50	12.10	1000.0	120.000	125.0	H	172.0	-15.2
203.404963	27.16	43.50	16.34	1000.0	120.000	125.0	H	218.0	-13.7
230.504797	20.43	46.00	25.57	1000.0	120.000	105.0	H	218.0	-12.8

6.4 Conducted Emissions

Reference

See Clause 6.2 of ANSI C63.10-2013

Methods of Measurement

The conducted emissions from the AC port of the EUT are measured in a shielding room. The EUT is connected to a Line Impedance Stabilization Network (LISN). An overview sweep with peak detection was performed. The measurements were performed with a quasi-peak detector and if required, an average detector. Tested in accordance with the procedures of ANSI C63.10-2013

The conducted emission measurements were made with the following detector of the test receiver Quasi-Peak / Average Detector.

Test Setup

The measurement bandwidth and Test Condition

Frequency (MHz)	RBW	Sweep Time (s)	Test Voltage
0.15-30	9 kHz	Auto	120V/60Hz

Test Setup

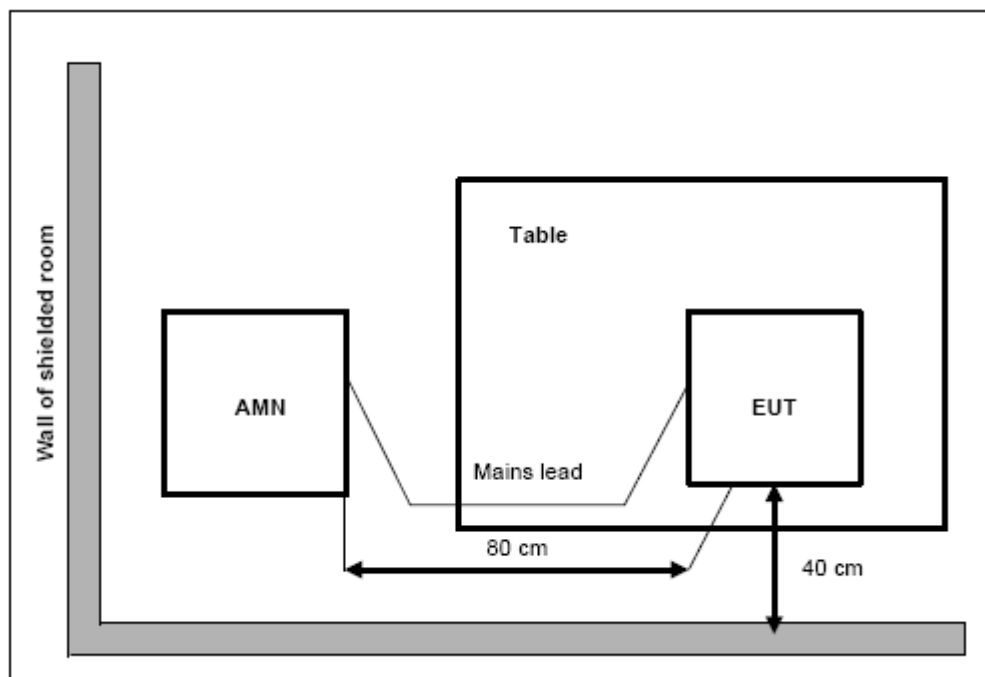

Limits

Frequency Range (MHz)	Conducted Limit (dBuV)	
	Quasi-peak	Average
0.15-0.5	66 to 56*	56 to 46*
0.5-5	56	46
5-30	60	50

*Decreases with the logarithm of the frequency

Measurement Results

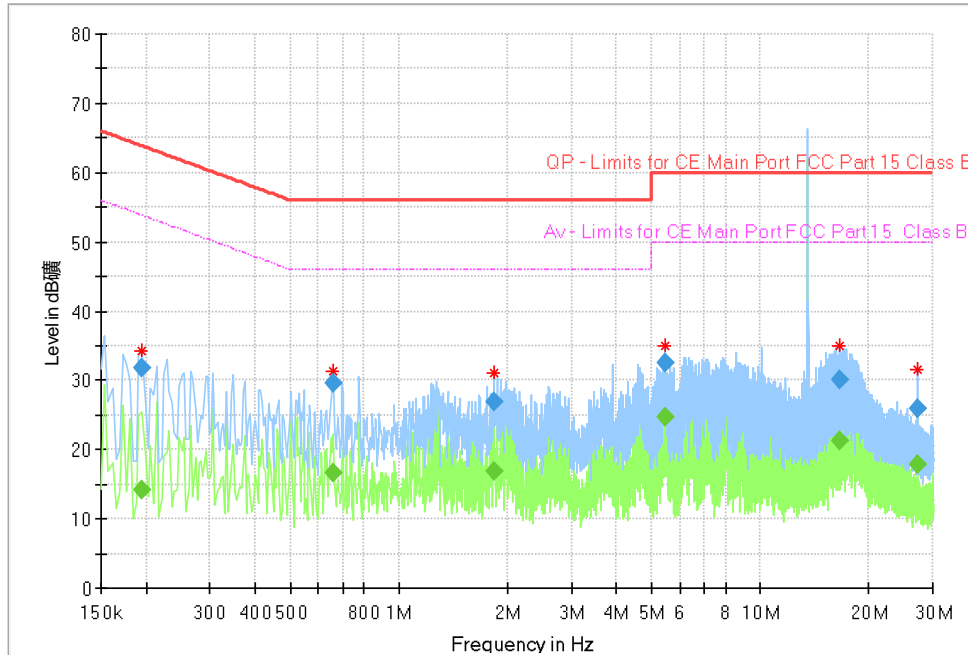

Figure 4 TX mode (150kHz-30MHz)

Frequency (MHz)	QuasiPeak (dB μ V)	Average (dB μ V)	Limit (dB μ V)	Margin (dB)	Meas. Time	Bandwidth (kHz)	Line	Filter	Corr. (dB)
0.194775	---	14.25	53.83	39.58	15000.	9.000	N	ON	9.6
0.194775	31.76	---	63.83	32.07	15000.	9.000	N	ON	9.6
0.657450	---	16.66	46.00	29.34	15000.	9.000	N	ON	9.6
0.657450	29.63	---	56.00	26.37	15000.	9.000	N	ON	9.6
1.829063	---	16.97	46.00	29.03	15000.	9.000	N	ON	9.6
1.829063	26.89	---	56.00	29.11	15000.	9.000	N	ON	9.6
5.448375	---	24.82	50.00	25.18	15000.	9.000	N	ON	9.8
5.448375	32.66	---	60.00	27.34	15000.	9.000	N	ON	9.8
16.518994	---	21.33	50.00	28.67	15000.	9.000	N	ON	10.1
16.518994	30.08	---	60.00	29.92	15000.	9.000	N	ON	10.1
27.123206	---	17.90	50.00	32.10	15000.	9.000	N	ON	10.3
27.123206	25.93	---	60.00	34.07	15000.	9.000	N	ON	10.3

Note:

1. Emission level(quasi-peak or Average peak)=Raw value by receiver + Corr(Insertion loss+ cable loss)
2. The raw value is used to calculate by software which is not shown in the sheet.
3. Margin=limit value – emission level.
4. L1 and N line is all have been tested , the result of them is synthesized in the above data diagram.
5. The frequency over the limits is the NFC main signal frequency.

6.5 Occupied bandwidth

Reference

See Clause 6.7 of RSS-Gen

Measurement Methods

The occupied bandwidth or the “99% emission bandwidth” is defined as the frequency range between two points, one above and the other below the carrier frequency, within which 99% of the total transmitted power of the fundamental transmitted emission is contained. The occupied bandwidth shall be reported for all equipment in addition to the specified bandwidth required in the applicable RSSs.

The following conditions shall be observed for measuring the occupied bandwidth:

- The transmitter shall be operated at its maximum carrier power measured under normal test conditions.
- The span of the spectrum analyzer shall be set large enough to capture all products of the modulation process, including the emission skirts, around the carrier frequency, but small enough to avoid having other emissions (e.g. on adjacent channels) within the span.
- The detector of the spectrum analyzer shall be set to “Sample”. However, a peak, or peak hold, may be used in place of the sampling detector since this usually produces a wider bandwidth than the actual bandwidth (worst-case measurement). Use of a peak hold (or “Max Hold”) may be necessary to determine the occupied / x dB bandwidth if the device is not transmitting continuously.
- The resolution bandwidth (RBW) shall be in the range of 1% to 5% of the actual occupied / x dB bandwidth and the video bandwidth (VBW) shall not be smaller than three times the RBW value. Video averaging is not permitted.

Note: It may be necessary to repeat the measurement a few times until the RBW and VBW are in compliance with the above requirement.

Test setup

Refer to Electric Field Radiated Emissions (Below 30MHz) of this report.

Measurement Results

Center Freq. (MHz)	Threshold Level	fL(MHz)	fH(MHz)
13.56	99 % OBW	13.559	13.560

7. Test Equipment List

Item	Equipment Name	Type	Serial Number	Manufacturer	Cal. Date	Cal. interval
1	Test Receiver	ESU40	100307	R&S	2021-03-03	1 year
2	Trilog Antenna	VULB9163	VULB9163-515	Schwarzbeck	2021-02-03	2 years
3	Loop Antenna	AL-130R	121083	COM-POWER	2019-12-26	3 years
4	EMI Test Software	EMC32 V9.15	N/A	R&S	N/A	N/A
5	Test Receiver	ESCI	101235	R&S	2021-05-10	1 year
6	2-Line V-Network	ENV216	101380	R&S	2021-03-20	1 year
7	EMI Test Software	EMC32 V10.35.02	N/A	R&S	N/A	N/A
8	Vector Signal Analyser	FSQ26	101096	R&S	2021-05-10	1 year
9	Climate chamber	B-TF-107C	201804107	Boyi	2021-05-10	1 year



Annex A: Measurement Uncertain

This uncertainty represents an expanded uncertainty expressed at approximately the 95% confidence level using a coverage factor of $k=2$.

Case	Uncertainty
20 dB bandwidth	60.8 Hz
Frequency Stability	60.8 Hz
Electric Field Strength of Fundamental Emissions	5.66 dB
Electric Field Radiated Emissions (Below 30MHz)	5.66 dB
Electric Field Radiated Emissions (Above 30MHz)	4.98 dB
Conducted Emissions	3.66 dB
Occupied bandwidth	60.8 Hz

Annex B: Accreditation Certificate



Accredited Laboratory

A2LA has accredited

INDUSTRIAL INTERNET INNOVATION CENTER (SHANGHAI) CO., LTD.

Shanghai, People's Republic of China

for technical competence in the field of

Electrical Testing

This laboratory is accredited in accordance with the recognized International Standard ISO/IEC 17025:2017 General requirements for the competence of testing and calibration laboratories. This accreditation demonstrates technical competence for a defined scope and the operation of a laboratory quality management system (refer to joint ISO-ILAC-IAF Communiqué dated April 2017).



Presented this 12th day of April 2021.



Vice President, Accreditation Services
For the Accreditation Council
Certificate Number 3682.01
Valid to February 28, 2023

For the tests to which this accreditation applies, please refer to the laboratory's Electrical Scope of Accreditation.

*****END OF REPORT*****