



TEST REPORT

No. I19D00082-EMC01

For

Client : Shanghai Sunmi Technology Co.,Ltd.

Production : Handheld Wireless Terminal

Model Name : T8A01

Brand Name: SUNMI

FCC ID: 2AH25T8A01

Hardware Version: V1.01

Software Version: L2K_V1.8_20190426

Issued date: 2019-08-15

NOTE

1. The test results in this test report relate only to the devices specified in this report.
2. This report shall not be reproduced except in full without the written approval of East China Institute of Telecommunications
3. The measurement uncertainty is not taken into account when deciding conformity, and the results of measurement (or the average of measurement results) are directly used as the criterion for the stating conformity.

Test Laboratory:

East China Institute of Telecommunications

Add: 7-8F, G Area, No.668, Beijing East Road, Huangpu District, Shanghai, P. R. China

Tel: +862163843300

FAX: +862163843301

E-Mail: welcome@ecit.org.cn

Revision Version

Report Number	Revision	Date	Memo
I19D00082-EMC01	00	2019-08-13	Initial creation of test report
I19D00082-EMC01	01	2019-08-15	Second creation of test report

CONTENTS

1. TEST LABORATORY	6
1.1. TESTING LOCATION	6
1.2. TESTING ENVIRONMENT	6
1.3. PROJECT DATA	6
1.4. SIGNATURE	6
2. CLIENT INFORMATION	7
2.1. APPLICANT INFORMATION	7
2.2. MANUFACTURER INFORMATION	7
3. EQUIPMENT UNDER TEST (EUT) AND ANCILLARY EQUIPMENT (AE)	8
3.1. ABOUT EUT	8
3.2. INTERNAL IDENTIFICATION OF EUT USED DURING THE TEST	8
3.3. INTERNAL IDENTIFICATION OF AE USED DURING THE TEST	8
4. REFERENCE DOCUMENTS.....	9
4.1 REFERENCE DOCUMENTS FOR TESTING	9
5. TEST RESULTS.....	10
5.1 SUMMARY OF TEST RESULTS	10
5.2 STATEMENTS.....	10
6. TEST EQUIPMENT UTILIZED	11
6.1 RADIATED EMISSION EQUIPMENT LIST	11
6.1 AC CONDUCTED EMISSION EQUIPMENT LIST	11
7. SYSTEM CONFIGURATION DURING TEST	12
7.1 TEST MODE.....	12
7.2 CONNECTION DIAGRAM OF TEST SYSTEM.....	13
8. MEASUREMENT RESULTS	14
8.1 RADIATED EMISSION 30MHZ-18GHZ.....	14

8.2 AC CONDUCTED EMISSION..... 18

1. Test Laboratory

1.1. Testing Location

Company Name: ECIT Shanghai, East China Institute of Telecommunications
Address: 7F, G Area, No. 668, Beijing East Road, Huangpu District, Shanghai,
P. R. China
Postal Code: 200001
Telephone: 86-21-63843300
Fax: 86-21-63843301
FCC registration No: 958356

1.2. Testing Environment

Normal Temperature: 15-35°C
Relative Humidity: 30-60%RH

1.3. Project data

Project Leader: Zhou Yan
Testing Start Date: 2019-06-18
Testing End Date: 2019-08-14

1.4. Signature

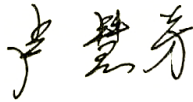

Lu Huifang
(Prepared this test report)



You Jinjun
(Reviewed this test report)

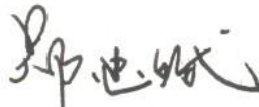

Zheng Zhongbin
(Approved this test report)

2. Client Information

2.1. Applicant Information

Company Name: Shanghai Sunmi Technology Co.,Ltd.
Address : Room 605, Block 7, KIC Plaza, No.388 Song Hu Road, Yang Pu
District, Shanghai, China
Telephone: 86-18721763396
Post Code: /

2.2. Manufacturer Information

Company Name: Shanghai Sunmi Technology Co.,Ltd.
Address : Room 605, Block 7, KIC Plaza, No.388 Song Hu Road, Yang Pu
District, Shanghai, China
Telephone: 86-18721763396
Post Code: /

3. Equipment under Test (EUT) and Ancillary Equipment (AE)

3.1. About EUT

EUT Description	Handheld Wireless Terminal
Model name	T8A01
GSM Frequency Band	GSM850/900/1800/1900
WCDMA Frequency Band	WCDMA Band I/II/IV/V/VIII
CDMA Frequency Band	BC0/BC1
LTE Frequency Band	LTE Band1/2/3/4/5/7/9/12/17/18/19/25/26/28/38/41
Additional Communication Function	BLE 4.0;WLAN 802.11a,b,g,n;GPS;NFC;MP3

3.2. Internal Identification of EUT used during the test

EUT ID*	SN or IMEI	HW Version	SW Version	Date of receipt
N06	863036040001653	V1.01	L2K_V1.8_20190426	2019-06-18
N02 (For RE_Data Link test)	/	V1.01	L2K_V1.8_20190426	2019-07-03

*EUT ID: is used to identify the test sample in the lab internally.

3.3. Internal Identification of AE used during the test

AE ID*	Description	Model	SN
CA03	Adapter	TPA-23A050200UU01	NA
CB01	Adapter	TPA-10D050200UU01	NA
UA05	USB Cable	USB CABLE 2.0A TO C-2DD021-101125	NA
BA04	Battery	JKJG	41981V8031000314
AE1	Desktop PC	OptiPlex 790 DT	X8RP1 A01 APCC
AE2	Notebook PC	DELL Latitude E6510	NA
AE3	LAN Cable	NA	NA
AE4	VGA Cable	NA	NA
AE5	RS232 Cable	NA	NA
AE6	Keyboard	KB212-B	CN-0Y88XT-65890-12I-005Q-A00
AE7	Mouse	MS111-P	CN-011D3V-71581-19J-1A64
AE8	Monitor	Dell E1709Wc	NA
AE9	USB Cable	NA	NA
AE10	SanDisk Ultra32GB	Kingston SDC4/4GB 77	NA
AE11	Earphone	BRE01JY	NA

*AE ID: is used to identify the test sample in the lab internally.

4. Reference Documents

4.1 Reference Documents for testing

The following documents listed in this section are referred for testing.

Reference	Title	Version
FCC Part 15, Subpart B	Radio frequency devices	2019/6/21
ANSI C63.4	Method of Measurement of Radio-Noise Emissions from Low-Voltage Electrical and Electronic Equipment in the Range of 9 kHz to 40 GHz	2014

5. Test Results

5.1 Summary of Test Results

Items	Test List	Clause in FCC rules	Verdict
1	Radiated Emission	15.109(a)	Pass
2	AC Conducted Emission	15.107(a)	Pass

5.2 Statements

The T8A01 manufactured by Shanghai Sunmi Technology Co.,Ltd. is a new model for testing. ECIT only performed test cases which identified with Pass/Fail/Inc result in section 5.1.

ECIT has verified that the compliance of the tested device specified in section 3 of this test report is successfully evaluated according to the procedure and test methods as defined in type certification requirement listed in section 4 of this test report.

6. Test Equipment Utilized

6.1 Radiated Emission Equipment list

Item	Instrument Name	Type	Serial Number	Manufacturer	Cal. Date	Cal. interval
1	Universal Radio Communication Tester	CMU200	123126	R&S	2019-05-10	1 year
2	Test Receiver	ESU40	100307	R&S	2019-05-10	1 year
3	Trilog Antenna	VULB9163	VULB9163-515	Schwarzbeck	2017-02-25	3 years
4	Double Ridged Guide Antenna	ETS-3117	00135885	ETS	2017-01-11	3 years
5	EMI Test Software	EMC32 V9.15	NA	R&S	NA	NA
6	Signal Generator	SMF 100A	102314	R&S	2019-05-10	1 year
7	GPS Simulator	GSS 4200	1182	SPIRENT	2018-12-17	1 year

6.1 AC Conducted Emission Equipment list

Item	Instrument Name	Type	Serial Number	Manufacturer	Cal. Date	Cal. interval
1	Universal Radio Communication Tester	CMU200	123123	R&S	2019-05-10	1 year
2	Test Receiver	ESCI	101235	R&S	2019-05-10	1 year
3	2-Line V-Network	ENV216	101380	R&S	2019-05-10	1 year
4	EMI Test Software	EMC32 V10.35.02	NA	R&S	NA	NA
5	Signal Generator	SMF 100A	102314	R&S	2019-05-10	1 year
6	GPS Simulator	GSS 4200	1182	SPIRENT	2018-12-17	1 year

7. System Configuration during Test

7.1 Test Mode

Test Item	Function Type
AC Conducted Emission	Mode 1: USB cable (Data Link with PC)+N02 <Figure 1> Mode 2: Adapter charging +CA03+N06 <Figure 2> Mode 3: Adapter charging +CB01+N06 <Figure 2> Mode 4: GPS mode+N06 <Figure 2> Mode 5: GSM 850 receiver <Figure 2>
Radiated Emission	Mode 1: USB cable (Data Link with PC)+N02 <Figure 1> Mode 2: Adapter charging +CA03+N06 <Figure 2> Mode 3: Adapter charging +CB01+N06 <Figure 2> Mode 4: GPS mode+N06 <Figure 2> Mode 5: GSM 850 receiver <Figure 2>
Remark: 1. All test modes are performed, only the worst cases test data are recorded in this report. 2. After laboratory verification, GSM850 receiver is the worst mode of receiving part. 3. Data Link with PC means data application transferred mode between EUT and PC. 4. EUT and GPS simulator (GSS4200) connection is established.	

7.2 Connection Diagram of Test System

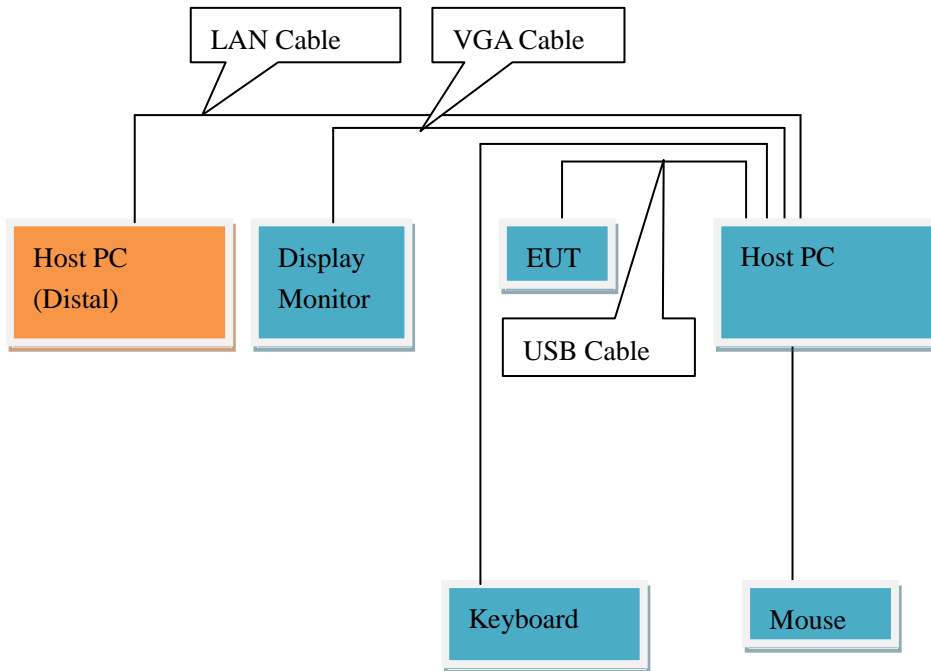

<Figure 1>

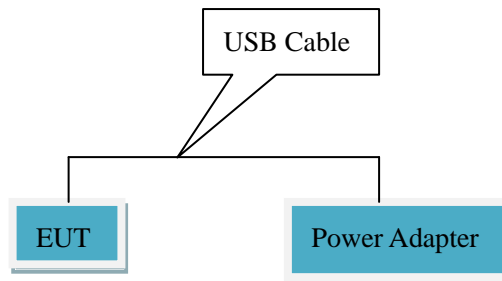

<Figure 2>

8. Measurement Results

Only the worst test result was shown in this report.

8.1 Radiated Emission 30MHz-18GHz

Method of Measurement

For 30MHz -1000MHz, the EUT was placed on the top of a rotating 0.8m table above the ground at a semi-anechoic chamber. The distance between the EUT and the received antenna was 3 meters. The table was rotated 360 degree and the received antenna mounted on a variable-height antenna tower was varied from 1m to 4m to find the maximum value of the field strength. Both horizontal and vertical polarizations of the antenna were set during the measurement. Tested in accordance with the procedures of ANSI C63.4-2014, section 8.3.

For 1000MHz-18000MHz, The maximal emission value was acquired by adjusting the antenna height, The table was rotated 360 degree to determine the maximum value of the field strength. Both horizontal and vertical polarizations of the antenna were set during the measurement.

Limits for Radiated Emission at a measuring distance of 3m

Frequency Range (MHz)	Quasi-Peak (dBuV/m)
30-88	40
88-216	43.5
216-960	46
Above 960	54

Frequency Range (MHz)	Peak (dBuV/m)	Average (dBuV/m)
Above 1000	74	54

Test conditions

Frequency Range (MHz)	RBW/VBW	Sweep Time (s)
30-1000	120kHz/300kHz	Auto
1000-18000	1MHz/3MHz	Auto

Uncertainty Measurement

The measurement uncertainty (30MHz-1000MHz) is 4.98 dB (k=2).

The measurement uncertainty (1000MHz-18000MHz) is 5.06 dB (k=2).

Test Results

Sweep the whole frequency band through the range from 30MHz to the 5th harmonic of the carrier, the Emissions in the frequency band 18GHz-40GHz is more than 20dB below the limit are not report.

Mode 1:USB cable (Data Link with PC)+N02 <Figure 1>

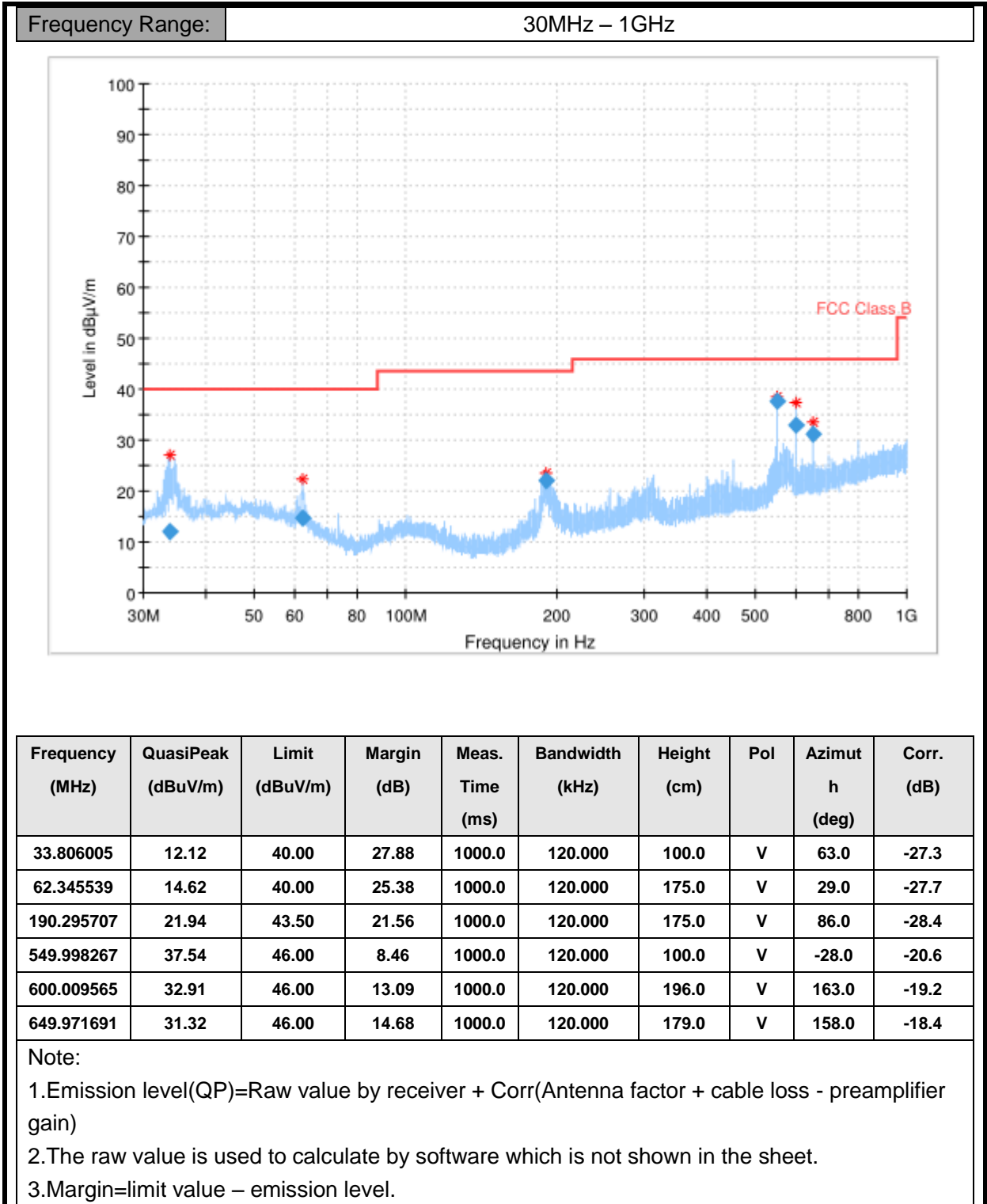

Mode 2: Adapter charging +CA03+N06 <Figure 2>

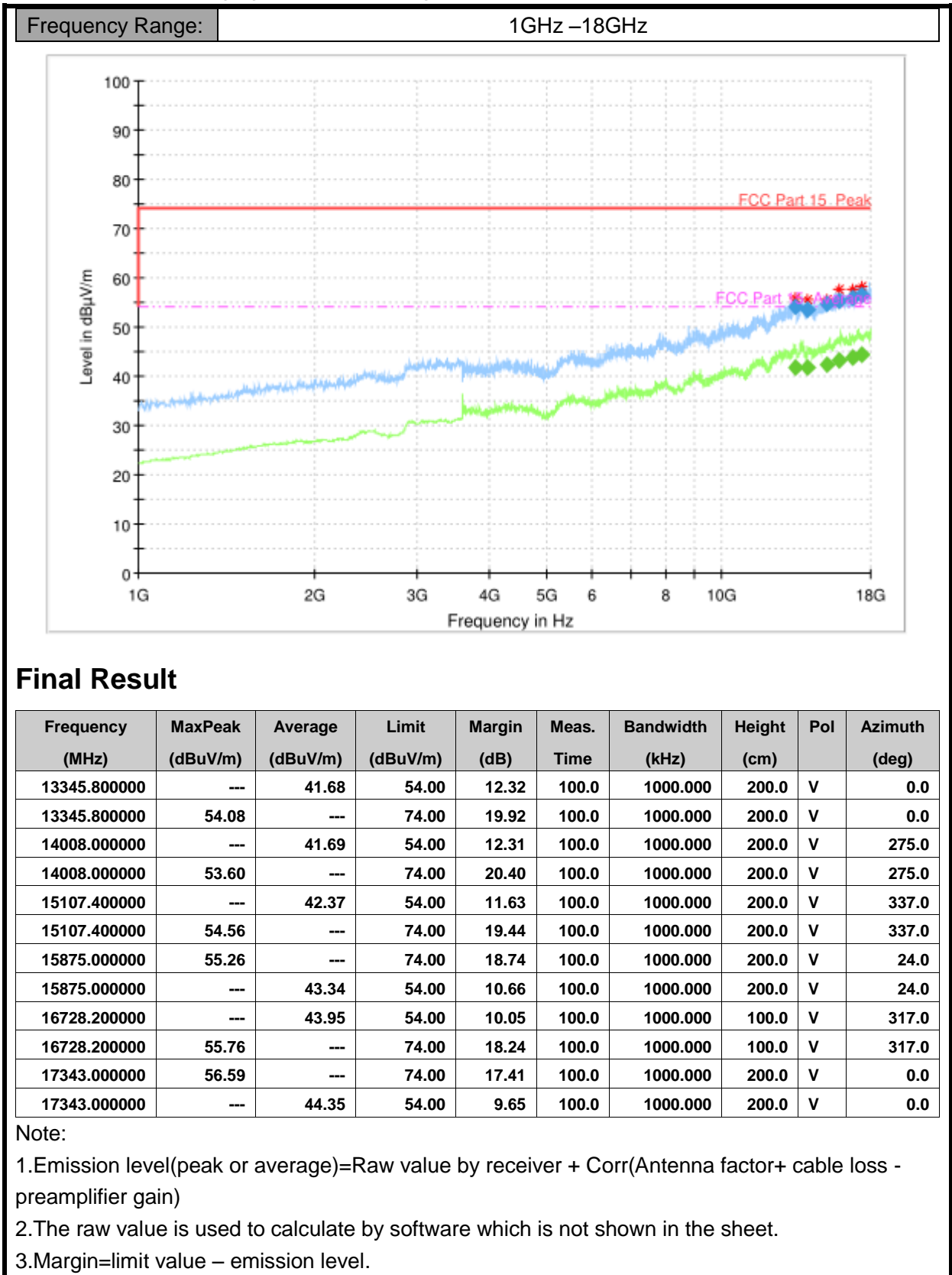

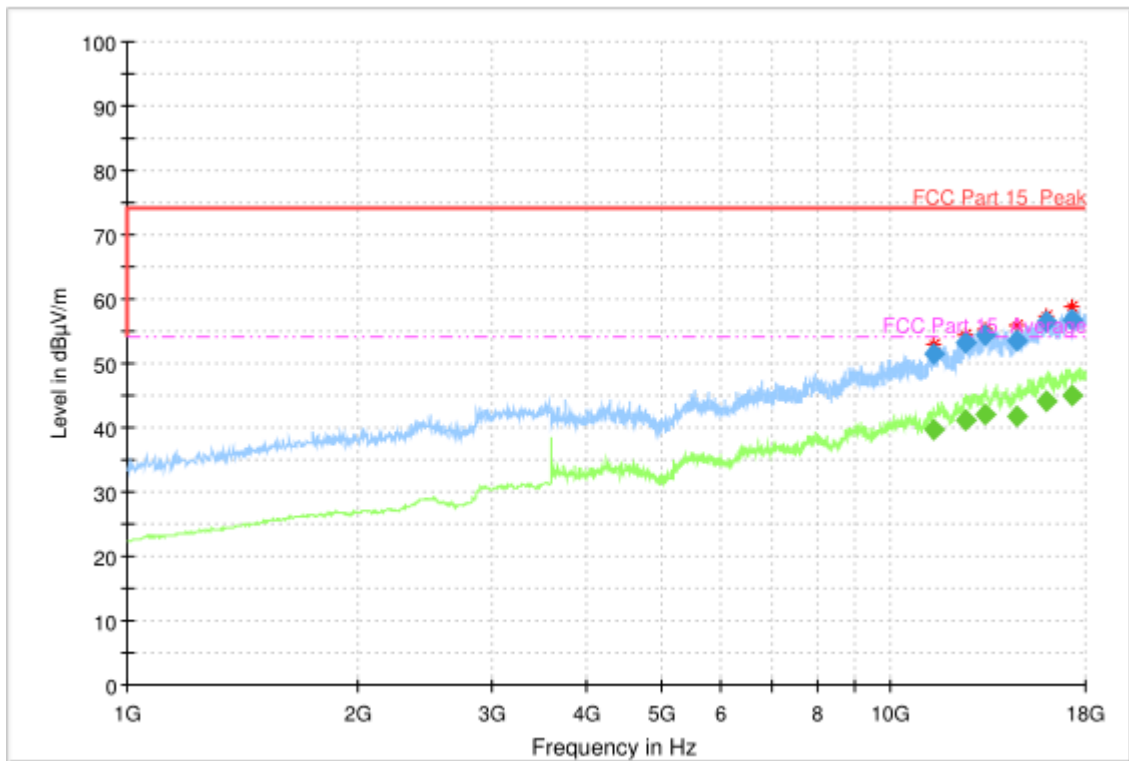

Final Result

Frequency (MHz)	MaxPeak (dBuV/m)	Average (dBuV/m)	Limit (dBuV/m)	Margin (dB)	Meas. Time	Bandwidth (kHz)	Height (cm)	Pol	Azimuth (deg)
11416.600000	---	39.73	54.00	14.27	100.0	1000.000	100.0	H	94.0
11416.600000	51.59	---	74.00	22.41	100.0	1000.000	100.0	H	94.0
12535.800000	53.18	---	74.00	20.82	100.0	1000.000	200.0	H	129.0
12535.800000	---	41.22	54.00	12.78	100.0	1000.000	200.0	H	129.0
13307.400000	54.40	---	74.00	19.60	100.0	1000.000	100.0	H	54.0
13307.400000	---	42.00	54.00	12.00	100.0	1000.000	100.0	H	54.0
14660.400000	53.67	---	74.00	20.33	100.0	1000.000	200.0	H	77.0
14660.400000	---	41.84	54.00	12.16	100.0	1000.000	200.0	H	77.0
16027.200000	---	44.13	54.00	9.87	100.0	1000.000	100.0	H	64.0
16027.200000	56.54	---	74.00	17.46	100.0	1000.000	100.0	H	64.0
17220.600000	56.75	---	74.00	17.25	100.0	1000.000	200.0	H	118.0
17220.600000	---	44.91	54.00	9.09	100.0	1000.000	200.0	H	118.0

Note:

- 1.Emission level(peak or average)=Raw value by receiver + Corr(Antenna factor+ cable loss - preamplifier gain)
- 2.The raw value is used to calculate by software which is not shown in the sheet.
- 3.Margin=limit value – emission level.

8.2 AC Conducted Emission

Method of Measurement

For equipment that is designed to be connected to the public utility (AC) power line, the radio frequency voltage that is conducted back onto the AC power line on any frequency or frequencies with the band 150 kHz to 30MHz shall not exceed the limits. Both lines of the power mains connected to the EUT were checked for maximum conducted interference. Tested in accordance with the procedures of ANSI C63.4-2014, section 7.3

Limit of Conducted Emission

Frequency Range (MHz)	Conducted Limit (dBuV)	
	Quasi-peak	Average
0.15-0.5	66 to 56*	56 to 46*
0.5-5	56	46
5-30	60	50

*Decreases with the logarithm of the frequency

Test Condition in Charging Mode

Voltage (V)	Frequency (Hz)	RBW	Sweep Time (s)
120	60	9 kHz	Auto

Uncertainty Measurement

The measurement uncertainty is 3.66dB (k=2).

Test Results

Mode 3: Adapter charging +CB01+N06 <Figure 2>

Frequency Range: 150kHz – 30MHz

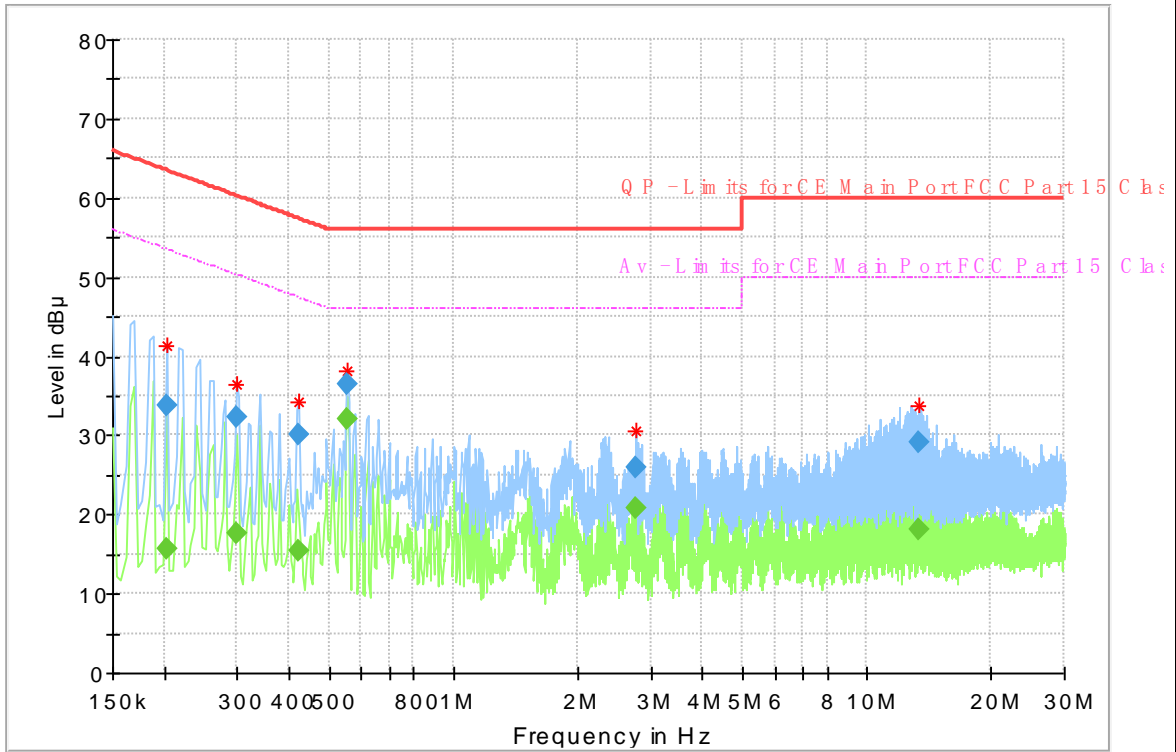

Frequency (MHz)	QuasiPeak (dBµ V)	Average (dBµ V)	Limit (dBµ V)	Margin (dB)	Meas. Time	Bandwidth (kHz)	Line	Filter	Corr. (dB)
0.202238	---	15.55	53.52	37.96	15000.	9.000	N	ON	9.8
0.202238	33.78	---	63.52	29.74	15000.	9.000	N	ON	9.8
0.299250	---	17.72	50.26	32.55	15000.	9.000	N	ON	9.8
0.299250	32.35	---	60.26	27.91	15000.	9.000	N	ON	9.8
0.422381	30.04	---	57.40	27.36	15000.	9.000	N	ON	9.8
0.422381	---	15.45	47.40	31.95	15000.	9.000	N	ON	9.8
0.552975	---	32.14	46.00	13.86	15000.	9.000	L1	ON	9.8
0.552975	36.44	---	56.00	19.56	15000.	9.000	L1	ON	9.8
2.758144	---	20.87	46.00	25.13	15000.	9.000	L1	ON	10.1
2.758144	25.95	---	56.00	30.05	15000.	9.000	L1	ON	10.1
13.399669	29.12	---	60.00	30.88	15000.	9.000	L1	ON	12.3
13.399669	---	18.02	50.00	31.98	15000.	9.000	L1	ON	12.3

Note:

1. Emission level (quasi-peak or Average peak) = Raw value by receiver + Corr (Insertion loss + cable loss)
2. The raw value is used to calculate by software which is not shown in the sheet.
3. Margin = limit value – emission level.
4. L1 and N line is all have been tested, the result of them is synthesized in the above data diagram.

*****END OF REPORT*****