



Industrial Internet Innovation Center (Shanghai) Co.,Ltd.

SRD TEST REPORT

PRODUCT	Smart POS System
BRAND	SUNMI
MODEL	T6F10
APPLICANT	Shanghai Sunmi Technology Co.,Ltd.
FCC ID	2AH25T6F10NA
IC	22621-T6F10
ISSUE DATE	September 9, 2024
STANDARD(S)	FCC Part15C, RSS-247 Issue 3, RSS-Gen Issue 5

Prepared by: *Li Haisheng*

李海生

Reviewed by: *Yang Fan*

杨帆

Approved by: *Zhang Min*

张旻

CAUTION:

This report shall not be reproduced except in full without the written permission of the test laboratory and shall not be quoted out of context.

CONTENTS

1. SUMMARY OF TEST REPORT	3
1.1 TEST STANDARD(S)	3
1.2 REFERENCE DOCUMENT(S).....	3
1.3 SUMMARY OF TEST RESULTS.....	3
1.4 DATA PROVIDED BY APPLICANT.....	4
2. GENERAL INFORMATION OF THE LABORATORY	5
2.1 TESTING LABORATORY	5
2.2 LABORATORY ENVIRONMENTAL REQUIREMENTS.....	5
2.3 PROJECT INFORMATION	5
3. GENERAL INFORMATION OF THE CUSTOMER	6
3.1 APPLICANT	6
3.2 MANUFACTURER	6
4. GENERAL INFORMATION OF THE PRODUCT.....	7
4.1 PRODUCT DESCRIPTION FOR EQUIPMENT UNDER TEST (EUT).....	7
4.2 INTERNAL IDENTIFICATION OF AE USED DURING THE TEST.....	7
4.3 ADDITIONAL INFORMATION	8
5. TEST CONFIGURATION INFORMATION	9
5.1 LABORATORY ENVIRONMENTAL CONDITIONS.....	9
5.2 TEST EQUIPMENTS UTILIZED.....	9
5.3 MEASUREMENT UNCERTAINTY	11
6. TEST RESULTS.....	13
6.1 PEAK OUTPUT POWER-CONDUCTED	13
6.2 99% OCCUPIED BANDWIDTH.....	16
6.3 PEAK POWER SPECTRAL DENSITY	19
6.4 6DB BANDWIDTH.....	22
6.5 FREQUENCY BAND EDGES-CONDUCTED	25
6.6 CONDUCTED EMISSION	27
6.7 RADIATED EMISSION.....	32
6.8 AC POWERLINE CONDUCTED EMISSION	44
ANNEX A: REVISED HISTORY	47
ANNEX B: ACCREDITATION CERTIFICATE.....	48

1. Summary of Test Report

1.1 Test Standard(s)

No.	Test Standard	Title	Version
1	FCC Part15C	FCC CFR 47, Part 15, Subpart C: 15.205 Restricted bands of operation; 15.209 Radiated emission limits, general requirements; 15.247 Operation within the bands 902-928MHz, 2400-2483.5MHz, and 5725-5850MHz.	--
2	RSS-247 Issue 3	Digital Transmission Systems (DTSs), Frequency Hopping Systems (FHSs) and Licence-Exempt Local Area Network (LE-LAN) Devices	2023
3	RSS-Gen Issue 5	General Requirements for Compliance of Radio Apparatus	2021

1.2 Reference Document(s)

No.	Test Standard	Title	Version
1	ANSI C63.10	American National Standard of Procedures for Compliance Testing of Unlicensed Wireless Devices	2013
2	KDB 558074 D01 15.247 Meas Guidance v05r02	Guidance for Performing Compliance Measurements on Frequency Hopping Spread Spectrum systems (DSS) Operating Under §15.247	--

Note: The standard of KDB 558074 D01 15.247 Meas Guidance v05r02 has not been accredited by A2LA.

1.3 Summary of Test Results

No.	Measurement Items	FCC Rules	IC Rules	Verdict
1	Maximum Peak Output Power	15.247(b)	RSS-247 5.4	Pass
2	Peak Power Spectral Density	15.247(e)	RSS-247 5.2	Pass
3	6dB Occupied Bandwidth	15.247(a)	RSS-247 5.2	Pass
4	99% Occupied Bandwidth	N/A	RSS-GEN 6.7	Pass
5	Band Edges Compliance	15.247(d)	RSS-247 5.5	Pass
6	Transmitter Spurious Emission-Conducted	15.247(d)	RSS-247 5.5	Pass
7	Transmitter Spurious Emission-Radiated	15.247/15.205/15.209	RSS-GEN 8.9, 8.10	Pass
8	AC Powerline Conducted Emission	15.207	RSS-GEN 8.8	Pass
9	Antenna requirement	15.203/15.247(c)	RSS Gen 6.8, RSS-247 5.4	Pass ^{Note 2}

Note 1:

The T6F10 manufactured by Shanghai Sunmi Technology Co.,Ltd. is a new product for testing. Industrial Internet Innovation Center (Shanghai) Co., Ltd. only performed test cases which identified with Pass/Fail/Inc result in section 1.3.

Industrial Internet Innovation Center (Shanghai) Co., Ltd. has verified that the compliance of the tested device specified in section 4 of this test report is successfully evaluated according to the procedure and test methods as defined in type certification requirement listed in section 1 of this test report.

Note 2:

Bluetooth used a FPC antenna with max Gain 2.21 dBi that complied with FCC 15.203 and ISSED rules Requirement.

Note:

- a. All the test data for each data were verified, but only the worst case was reported.

1.4 Data Provided by Applicant

No.	Item(s)	Data
1	Antenna gain of EUT	2.21 dBi

Note: The data of antenna gain is provided by the Antenna specification may affect the validity of the test results in this report, and the impact and consequences of this shall be undertaken by the customer.

2. General Information of The Laboratory

2.1 Testing Laboratory

Lab Name	Industrial Internet Innovation Center (Shanghai) Co.,Ltd.
Address	Building 4, No. 766, Jingang Road, Pudong, Shanghai, China
Telephone	021-68866880
FCC Registration No.	708870
FCC Designation No.	CN1364
IC Designation No.	10766A
CAB identifier	CN0067

2.2 Laboratory Environmental Requirements

Temperature	15°C~35°C
Relative Humidity	25%RH~75%RH
Atmospheric Pressure	86kPa~106kPa

2.3 Project Information

Project Manager	Gao Hongning
Test Date	July 10,2024 to August 25,2024

3. General Information of The Customer

3.1 Applicant

Company	Shanghai Sunmi Technology Co.,Ltd.
Address	Room 505, No.388 Song Hu Road, Yang Pu District, Shanghai, China
Telephone	18826519551

3.2 Manufacturer

Company	Shanghai Sunmi Technology Co.,Ltd.
Address	Room 505, No.388 Song Hu Road, Yang Pu District, Shanghai, China
Telephone	18826519551

4. General Information of The Product

4.1 Product Description for Equipment under Test (EUT)

Product Name	Smart POS System
Model name	T6F10
Date of Receipt	S05aa:July 10,2024 S07aa:July 10,2024
EUT ID*	S05aa/S07aa
SN/IMEI	S05aa: 868393070000286'868393070002282 S07aa: 868393070001573'868393070003579
Supported Radio Technology and Bands	WCDMA Band II/IV/V LTE Band 2/4/5/7/12/13/14/17/25/26/30/38/41/66/71 WLAN 802.11b/g/n WLAN 802.11a/n/ac BT 5.0 BR/EDR/BLE NFC GPS/Galileo
Hardware Version	V1.0(NA)
Software Version	V3.0.0
HVIN	T6F10
FCC ID	2AH25T6F10NA
IC	22621-T6F10
Power Rating	DC 7.7V form battery,DC 5V form adapter
NOTE1: EUT ID is the internal identification code of the laboratory. NOTE2: Samples in the test report are provided by the customer. The test results are only applicable to the samples received by the laboratory.	

4.2 Internal Identification of AE used during the test

AE ID*	Description	Model	SN/Remark
AE1	RF Cable	N/A	N/A
CA01	Adapter	TPA-141A050200UU01	N/A
CB01	Adapter	UC13US	N/A
CC01	Adapter	TPA-23A050200UU01	N/A
UA01	AC Cable	N/A	N/A
BA02	Battery	HPPA	Guangdong Highpower NewEnergy Technology Co., Ltd.

NOTE1: AE ID is the internal identification code of the laboratory.

NOTE2: By verifying that CC01+BA02 is the worst battery and adapter combination, this battery and adapter are used in all tests.

4.3 Additional Information

BLE Frequency	2402MHz-2480MHz
BLE Channel	Ch0-39
BLE Modulation	GFSK

Test frequency list:

BLE_1M	Channel	0	19	39
	Freq. (MHz)	2402	2440	2480

Note: This report is for BLE only.

Emissions Information:

TestMode	Frequency Min(MHz)	Frequency Max(MHz)	Max OutPut Power EIRP(dBm)	Max OutPut Power EIRP(W)	OBW (KHz)	Necessary Bandwidth & Emission Classification
1M	2402	2480	0.07	0.0010	1072	1M07F1D
2M	2402	2480	0.10	0.0010	2104	2M10F1D

5. Test Configuration Information

5.1 Laboratory Environmental Conditions

5.1.1 Permanent Facilities

Relative Humidity	Min. = 45 %, Max. = 55 %		
Atmospheric Pressure	101kPa		
Temperature	Normal	Minimum	Maximum
	25°C	-10°C	50°C
Working Voltage of EUT	Normal	Minimum	Maximum
	7.7V	6.0V	8.8V

5.2 Test Equipments Utilized

5.2.1 Conducted Test System

No.	Name	Model	S/N	SW Version	HW Version	Manufacturer	Cal. Date	Cal. Interval
1	Test Software	TS1120	10671	V3.2.22	N/A	Tonscend	N/A	N/A
2	Automatic control unit	JS0806-2	2218060621	N/A	N/A	Tonscend	2024-03-25	1 year
3	Wireless communication comprehensive tester	CMW270	100919	V3.5.137	N/A	R&S	2023-07-26	1 year
							2024-07-25	
4	Spectrum Analyzer	FSQ40	200063	V4.75	N/A	R&S	2023-10-16	1 year
5	Vector Signal Generator	SMU200A	104684	V03.20.286.21	N/A	R&S	2023-07-26	1 year
							2024-07-25	
6	Vector Signal Generator	SMBV100A	257904	V4.15.125.49	N/A	R&S	2023-12-19	1 Year
7	Programmable Power Supply	Keithley 2303	4039070	N/A	N/A	Keithley	2024-06-07	1 Year
8	Temperature box	B-TF-107C	BTF107C-201804107	N/A	N/A	Boyi	2024-06-07	1 Year
9	Network test unit AP	GT-AXE11000	N2IG0X401637KWF	V3.0.0.4.386_45940	N/A	ASUS	N/A	N/A

5.2.2 Radiated Emission Test System

No	Name	Model	S/N	SW Version	HW Version	Manufacturer	Cal. Date	Cal. Interval
1	Universal Radio Communication Tester	CMU200	123126	V5.2.1	B12	R&S	2023-10-16	1 Year
2	Universal Radio Communication Tester	CMW500	104178	V3.7.20	1206.0600.00	R&S	2023-10-16	1 Year
3	EMI Test Receiver	ESU40	100307	V5.1-24-3	01	R&S	2023-12-19	1 Year
4	TRILOG Broadband Antenna	VULB9163	01345	N/A	N/A	Schwarzbeck	2024-03-29	1 Year
5	Double-ridged Waveguide Antenna	ETS-3117	00135890	N/A	N/A	ETS	2024-03-16	1 Years
6	EMI Test Software	EMC32 V10.35.02	N/A	V10.35.02	N/A	R&S	N/A	N/A
7	Horn Antenna	3160-09	LM6321	N/A	N/A	R&S	2023-07-16 2024-07-15	1 Years
8	Horn Antenna	3160-10	LM5942	N/A	N/A	R&S	2023-07-16 2024-07-15	1 Years
9	Loop Antenna	AL-130R	121083	N/A	N/A	COM-POWER	2023-09-13	1 year
10	Preamplifier	SCU08F1	8320024	N/A	N/A	R&S	2023-10-16	1 year
11	Preamplifier	SCU18	10155	N/A	N/A	R&S	2023-10-16	1 year
12	Preamplifier	SCU26	10025	N/A	N/A	R&S	2023-10-16	1 year
13	Preamplifier	SCU40	10020	N/A	N/A	R&S	2023-10-16	1 year
14	2-Line V-Network	ENV216	101380	N/A	N/A	R&S	2023-12-19	1 year
15	EMI Test Software	EMC32 V10.35.02	N/A	N/A	N/A	R&S	N/A	N/A
16	Test Receiver	ESCI	101235	V5.1-24-3	0	R&S	2023-12-19	1 year
17	Antenna Tower	TPMDC-LF	N/A	N/A	N/A	Top Precision	N/A	N/A
18	Antenna Tower	TPMDC-HF	N/A	N/A	N/A	Top Precision	N/A	N/A

5.2.3 Test Environment

Shielding Room1 (6.0 meters×3.0 meters×2.7 meters) did not exceed following limits along the conducted RF performance testing:

Temperature	Min. = 15 °C, Max. = 35 °C
Relative humidity	Min. = 20 %, Max. = 75 %
Shielding effectiveness	> 100 dB
Ground system resistance	< 0.5 Ω
Temperature	Min. = 15 °C, Max. = 35 °C

Control room did not exceed following limits along the EMC testing:

Temperature	Min. = 15 °C, Max. = 35 °C
Relative humidity	Min. = 30 %, Max. = 60 %
Shielding effectiveness	> 100 dB
Electrical insulation	> 10 kΩ
Ground system resistance	< 0.5 Ω

Fully-anechoic chamber1 (9.8 meters×6.7 meters×6.7 meters) did not exceed following limits along the EMC testing:

Temperature	Min. = 15 °C, Max. = 35 °C
Relative humidity	Min. = 25 %, Max. = 75 %
Shielding effectiveness	> 100 dB
Electrical insulation	> 10 kΩ
Ground system resistance	< 0.5 Ω
VSWR	Between 0 and 6 dB, from 1GHz to 18GHz
Site Attenuation Deviation	Between -4 and 4 dB, 30MHz to 1GHz

5.3 Measurement Uncertainty

Measurement Uncertainty of Conduction test

Item(s)	Frequency range	Confidence Level	Uncertainty
DTS Bandwidth	2400–2483.5MHz	95%	±1.9%
Maximum Conducted Output Power	2400–2483.5MHz	95%	± 1.18 dB
Maximum Power Spectral Density Level	2400–2483.5MHz	95%	±0.98 dB
Band-edge Compliance	2400–2483.5MHz	95%	±1.21dB
Unwanted Emissions In Non-restricted Freq Bands	9kHz-7GHz	95%	9kHz-7GHz:±1.21dB

	7GHz-40GHz	95%	7GHz-40GHz:±3.31dB
--	------------	-----	--------------------

Measurement Uncertainty of Radiation test

Measurement Items	Uncertainty(dB)
Radiated Emission 30MHz-1000MHz	±5.10
Radiated Emission 1000MHz-18000MHz	±5.66
Radiated Emission 18000MHz-40000MHz	±5.22
AC Powerline Conducted Emission	±4.38

Note: This uncertainty represents an expanded uncertainty expressed at approximately the 95% confidence level using a coverage factor of k=2.

6. Test Results

6.1 Peak Output Power-Conducted

6.1.1 Measurement Limit

Standard	Conducted Limit(dBm)	EIRP Limit(dBm)
FCC 47 Part 15.247(b)(3)	<30	N/A
RSS-247 5.4(d)	<30	<36

6.1.2 Test Condition

DTS procedure	RBW	VBW	Span	Sweeptime
BT-LE	2MHz	5MHz	6MHz	Auto

6.1.3 Test Procedure

The measurement is according to ANSI C63.10 clause 11.9.1

- a) Set the $RBW \geq DTS$ bandwidth.
- b) Set $VBW \geq [3 \times RBW]$.
- c) Set span $\geq [3 \times RBW]$.
- d) Sweep time = auto couple.
- e) Detector = peak.
- f) Trace mode = max hold.
- g) Allow trace to fully stabilize.
- h) Use peak marker function to determine the peak amplitude level.

6.1.4 Test setup

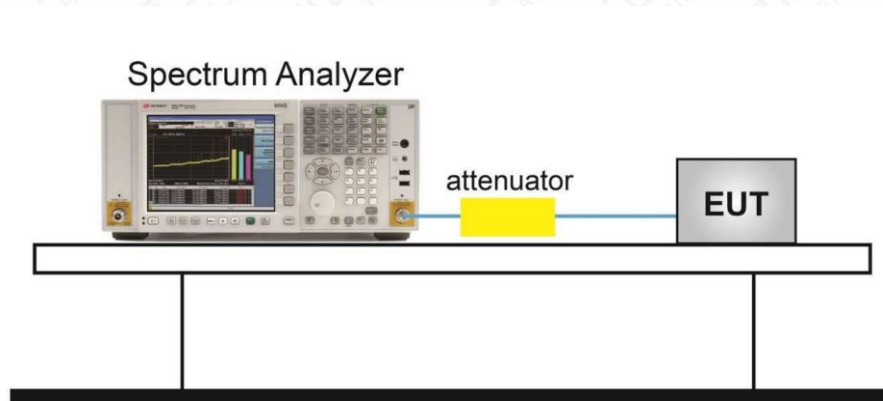

Note: The attenuator shown in the figure is the attenuation of the entire test system.

6.1.5 Measurement Results

TestMode	Antenna	Frequency[MHz]	Conducted Peak Power[dBm]	Conducted Limit[dBm]	EIRP[dBm]	EIRP Limit[dBm]	Verdict
BLE_1M	Ant1	2402	-2.50	≤30	-0.29	≤36	PASS
BLE_1M	Ant1	2440	-2.14	≤30	0.07	≤36	PASS
BLE_1M	Ant1	2480	-3.26	≤30	-1.05	≤36	PASS
BLE_2M	Ant1	2402	-2.60	≤30	-0.39	≤36	PASS
BLE_2M	Ant1	2440	-2.11	≤30	0.10	≤36	PASS
BLE_2M	Ant1	2480	-3.28	≤30	-1.07	≤36	PASS

Test Graphs Peak

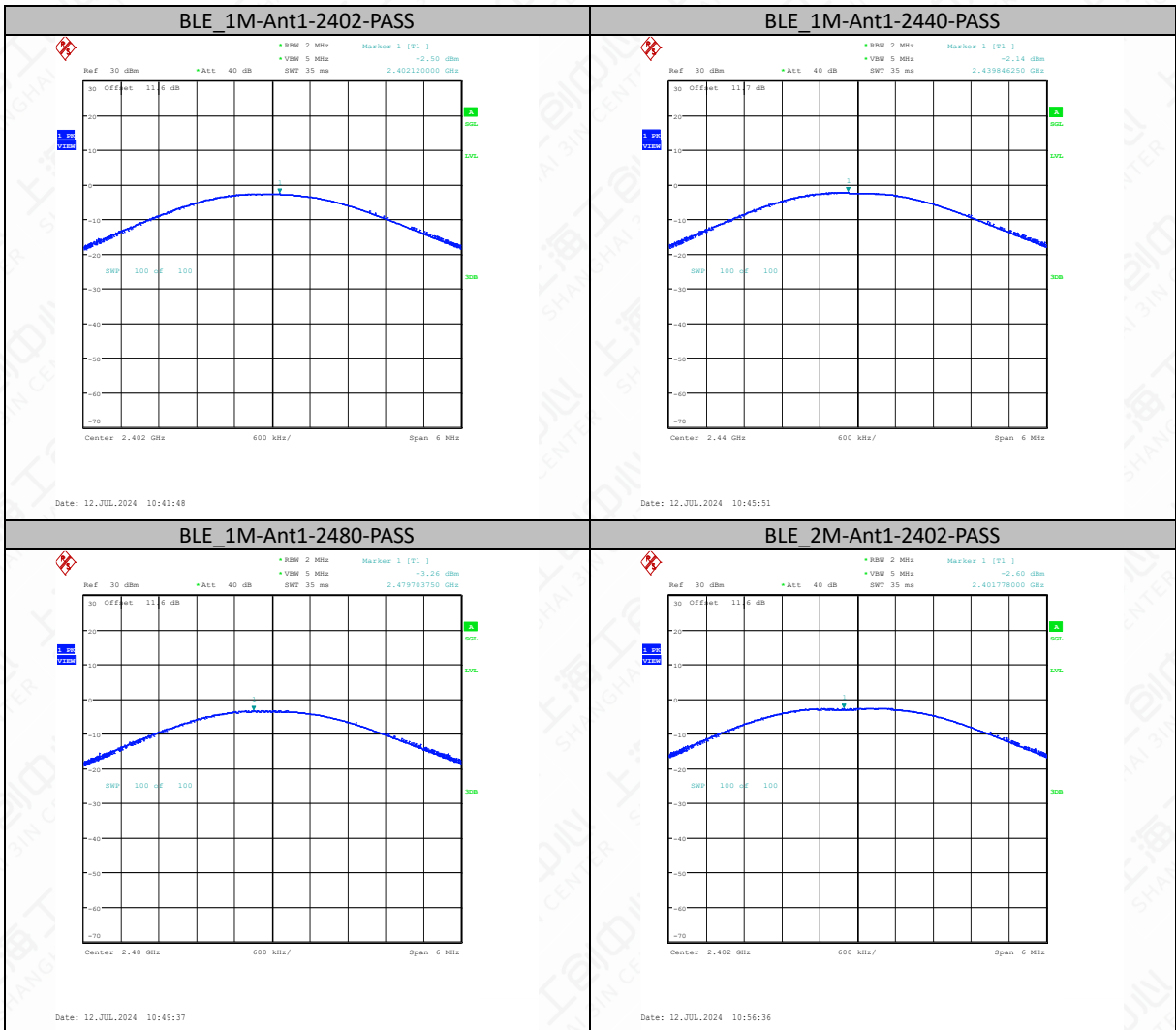

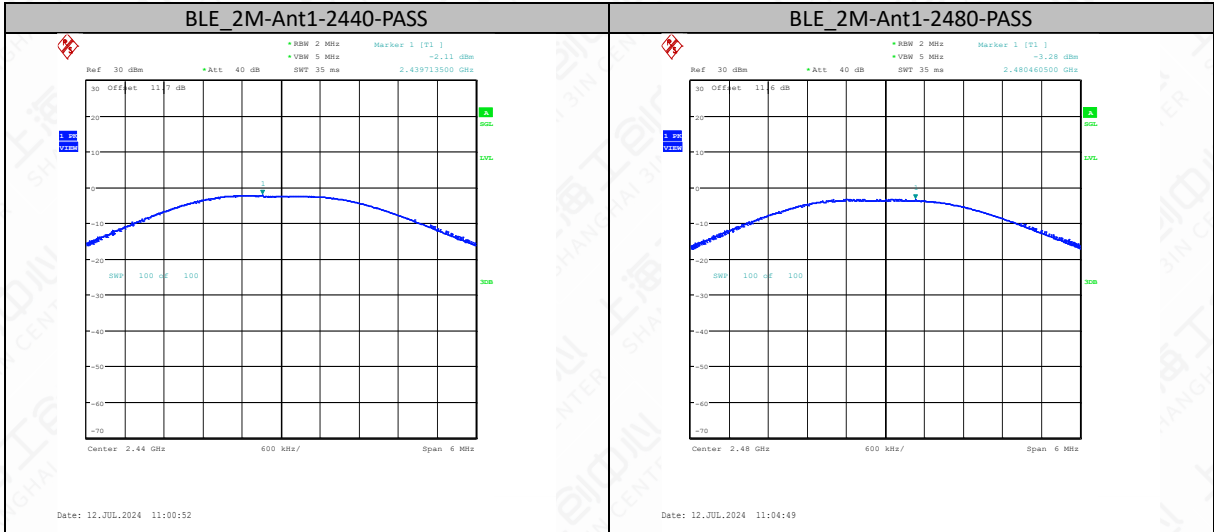

6.2 99% Occupied Bandwidth

6.2.1 Measurement Limit

Standard	Limit
15.247(a)	N/A
RSS-Gen 6.7	N/A

6.2.2 Test procedures

The measurement is according to ANSI C63.10 clause 6.9.3.

1. The output power of EUT was connected to the spectrum analyzer. The path loss was compensated to the results for each measurement.
2. Enable EUT transmitter maximum power continuously.
3. Set RBW shall be in the range of 1% to 5% of the OBW.
4. Set the VBW $\geq [3 \times \text{RBW}]$.
5. Detector = peak.
6. Trace mode = max hold.
7. Sweep = auto couple.
8. Allow the trace to stabilize.
9. The occupied bandwidth is the frequency bandwidth such that, below its lower and above its upper frequency limits, the mean powers are each equal to 0.5% of the total mean power of the given emission.

6.2.3 Test setup

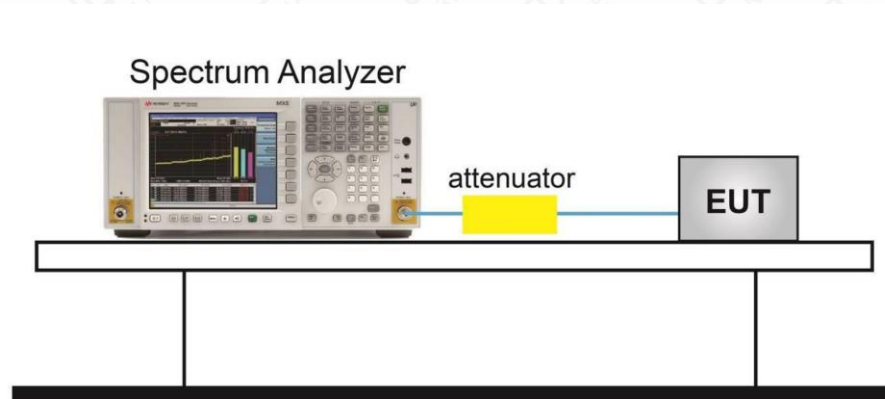

Note: The attenuator shown in the figure is the attenuation of the entire test system.

6.2.4 Measurement Result

TestMode	Antenna	Frequency[MHz]	OCB [MHz]	FL[MHz]	FH[MHz]	Limit[MHz]	Verdict
BLE_1M	Ant1	2402	1.056	2401.4720	2402.5280	---	---
BLE_1M	Ant1	2440	1.064	2439.4680	2440.5320	---	---
BLE_1M	Ant1	2480	1.072	2479.4600	2480.5320	---	---
BLE_2M	Ant1	2402	2.096	2400.9600	2403.0560	---	---
BLE_2M	Ant1	2440	2.08	2438.9640	2441.0440	---	---
BLE_2M	Ant1	2480	2.104	2478.9520	2481.0560	---	---

Test graphs

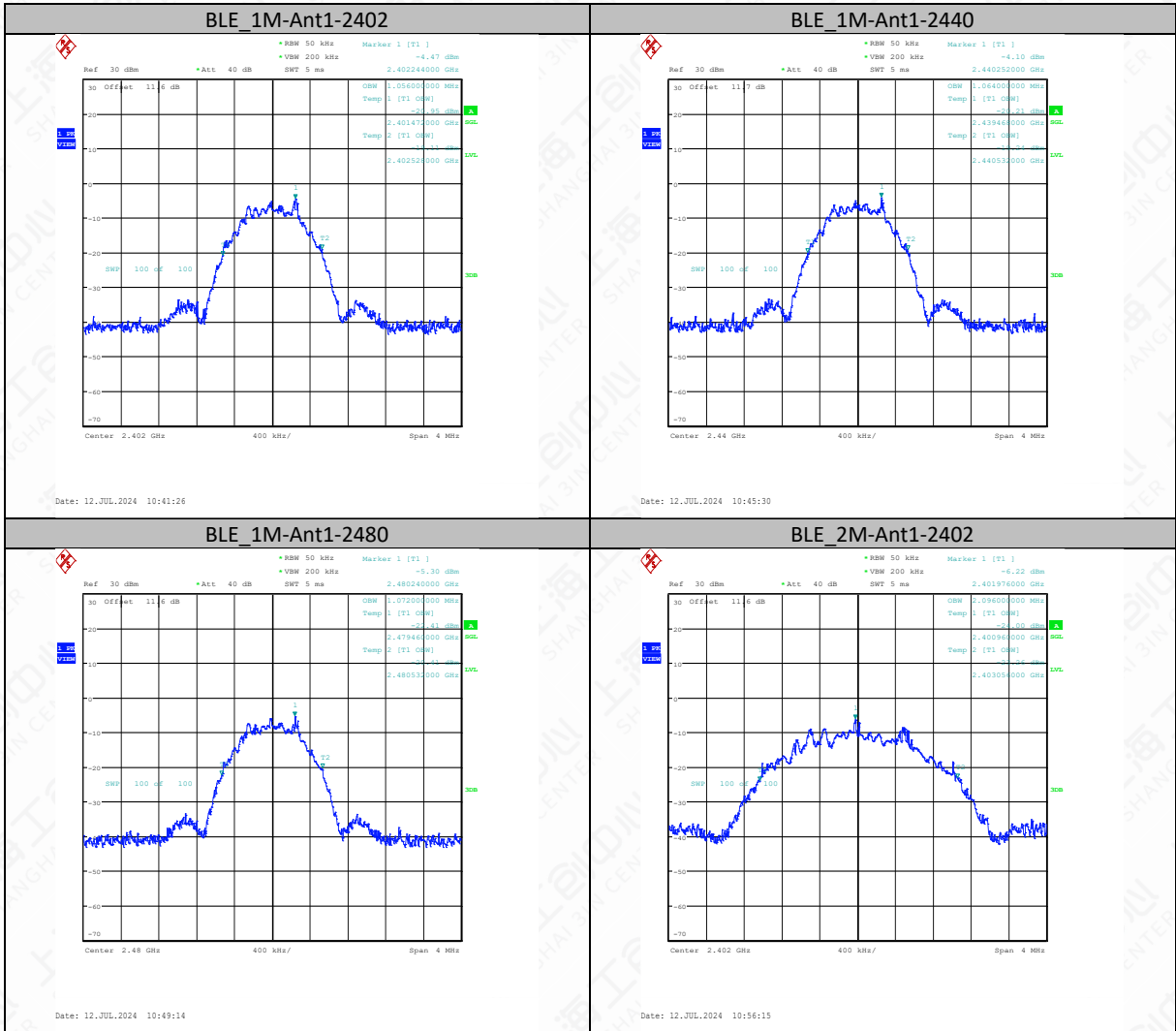

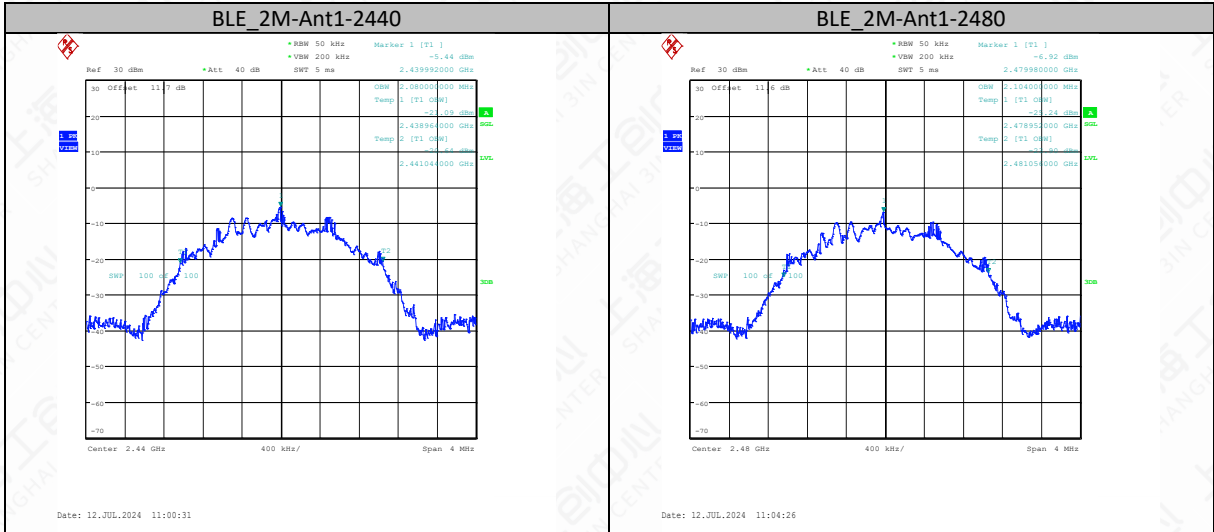

6.3 Peak Power Spectral Density

6.3.1 Measurement Limit

Standard	Limit
FCC 47 Part 15.247(e)	$\leq 8\text{dBm}/3\text{ kHz}$
RSS-247 5.2(b)	$\leq 8\text{dBm}/3\text{ kHz}$

6.3.2 Test procedures

The measurement is according to ANSI C63.10 clause 11.10.

1. The output power of EUT was connected to the spectrum analyzer. The path loss was compensated to the results for each measurement.
2. Enable EUT transmitter maximum power continuously.
3. Set analyzer center frequency to DTS channel center frequency.
4. Set the span to 1.5 times the DTS bandwidth.
5. Set the RBW to $3\text{ kHz} \leq \text{RBW} \leq 100\text{ kHz}$.
6. Set the VBW $\geq [3 \times \text{RBW}]$.
7. Detector = peak.
8. Sweep time = auto couple.
9. Trace mode = max hold.
10. Allow trace to fully stabilize.
11. Use the peak marker function to determine the maximum amplitude level within the RBW.
12. If measured value exceeds requirement, then reduce RBW (but no less than 3 kHz) and repeat.

6.3.3 Test Setup

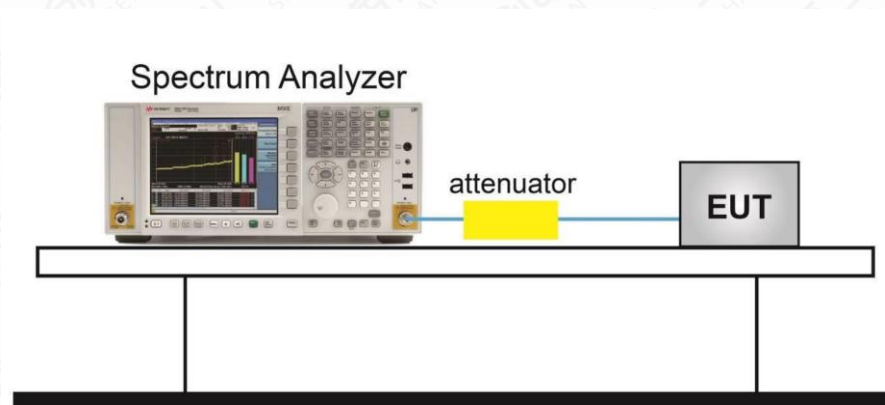

Note: The attenuator shown in the figure is the attenuation of the entire test system.

6.3.4 Measurement Results

TestMode	Antenna	Frequency[MHz]	Result[dBm/3kHz]	Limit[dBm/3kHz]	Verdict
BLE_1M	Ant1	2402	-19.77	≤ 8.00	PASS
BLE_1M	Ant1	2440	-19.25	≤ 8.00	PASS
BLE_1M	Ant1	2480	-20.46	≤ 8.00	PASS
BLE_2M	Ant1	2402	-22.09	≤ 8.00	PASS
BLE_2M	Ant1	2440	-21.57	≤ 8.00	PASS

BLE_2M	Ant1	2480	-22.73	≤8.00	PASS
--------	------	------	--------	-------	------

Test Graphs

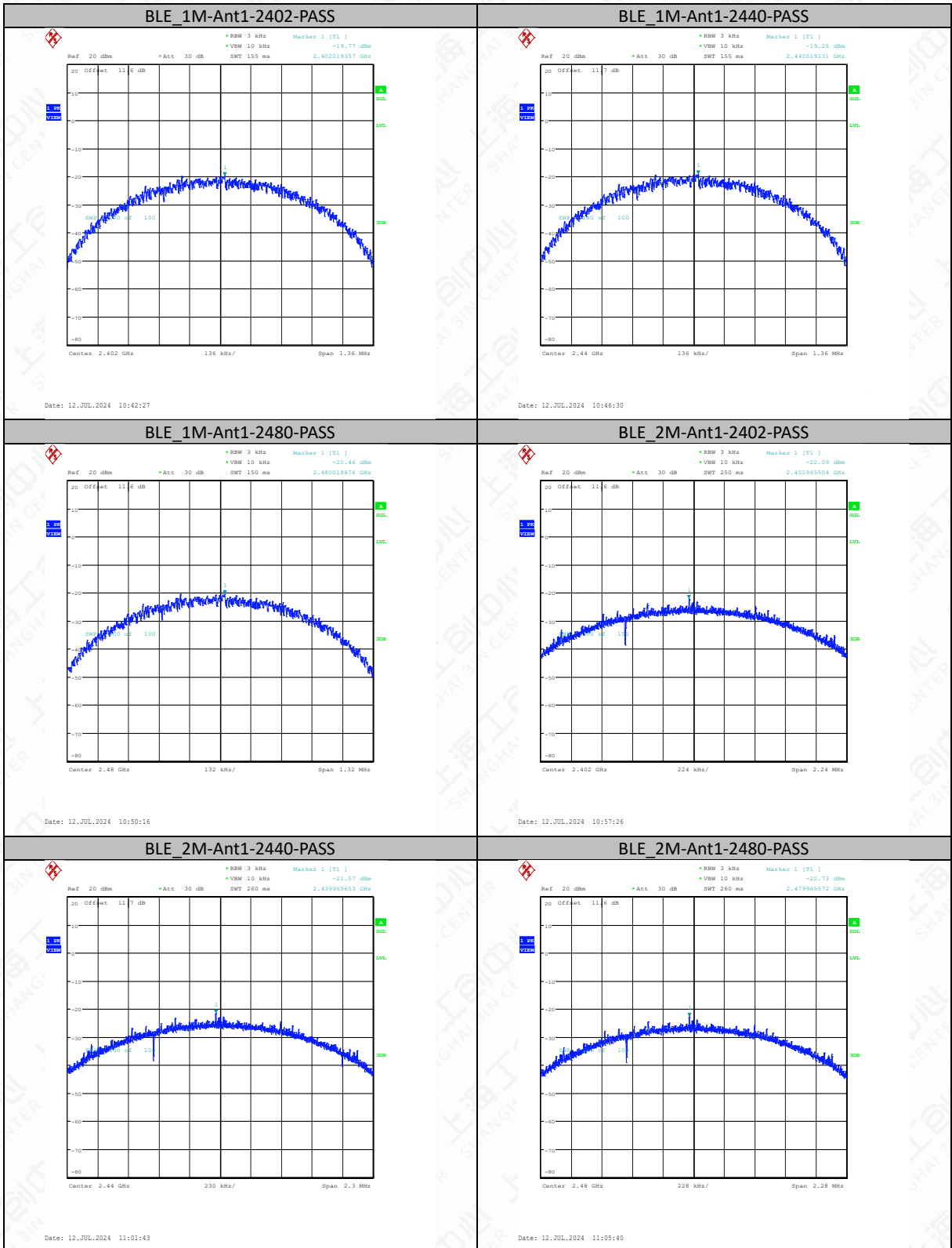

6.4 6dB Bandwidth

6.4.1 Measurement Limit

Standard	Limit
FCC 47 Part 15.247 (a) (2)	≥500kHz
RSS-247 5.2(a)	≥ 500kHz

6.4.2 Test procedures

The measurement is according to ANSI C63.10 clause 11.8.

1. The output power of EUT was connected to the spectrum analyzer. The path loss was compensated to the results for each measurement.
2. Enable EUT transmitter maximum power continuously.
3. Set RBW = 100 kHz.
4. Set the VBW ≥ [3 × RBW].
5. Detector = peak.
6. Trace mode = max hold.
7. Sweep = auto couple.
8. Allow the trace to stabilize.
9. Measure the maximum width of the emission that is constrained by the frequencies associated with the two outermost amplitude points (upper and lower frequencies) that are attenuated by 6 dB relative to the maximum level measured in the fundamental emission.

6.4.3 Test Setup

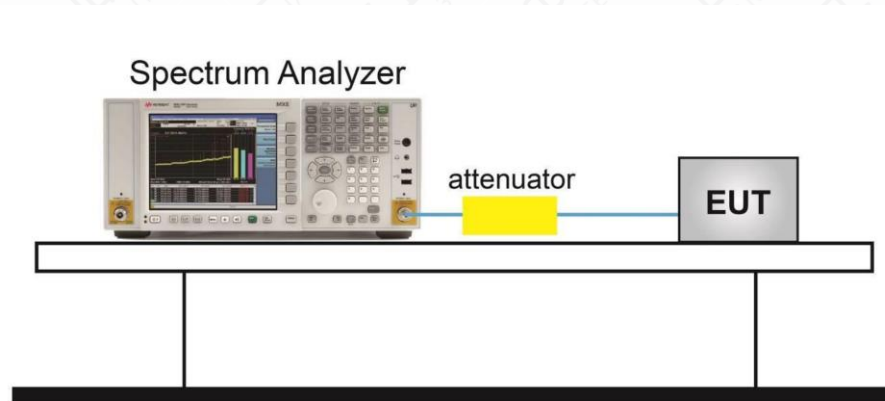

Note: The attenuator shown in the figure is the attenuation of the entire test system.

6.4.4 Measurement Result

TestMode	Antenna	Frequency[MHz]	DTS BW [MHz]	FL[MHz]	FH[MHz]	Limit[MHz]	Verdict
BLE_1M	Ant1	2402	0.68	2401.66	2402.34	0.5	PASS
BLE_1M	Ant1	2440	0.68	2439.65	2440.34	0.5	PASS
BLE_1M	Ant1	2480	0.66	2479.67	2480.33	0.5	PASS
BLE_2M	Ant1	2402	1.12	2401.45	2402.57	0.5	PASS
BLE_2M	Ant1	2440	1.15	2439.44	2440.58	0.5	PASS
BLE_2M	Ant1	2480	1.14	2479.44	2480.58	0.5	PASS

Test Graphs

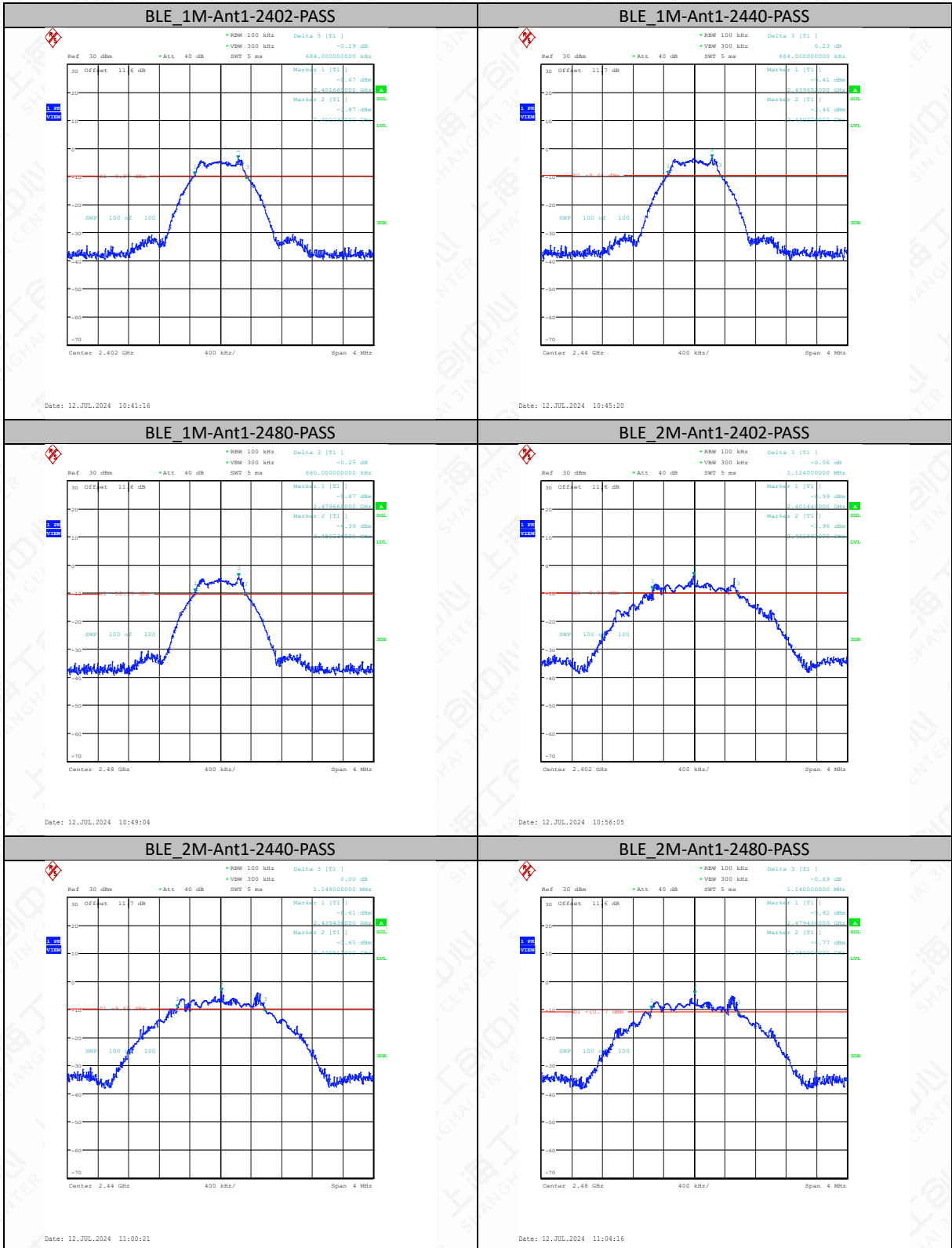

6.5 Frequency Band Edges-Conducted

6.5.1 Measurement Limit

Standard	Limit(dBc)
FCC 47 Part 15.247(d)	>20
RSS-247 5.5	>20

6.5.2 Test procedures

The measurement is according to ANSI C63.10 clause 11.13.2

- 1) Span: Wide enough to capture the peak level of the emission operating on the channel closest to the band edge, as well as any modulation products that fall outside of the authorized band of operation.
- 2) Reference level: As required to keep the signal from exceeding the maximum instrument input mixer level for linear operation. In general, the peak of the spectral envelope shall be more than [10 log (OBW/RBW)] below the reference level. Specific guidance is given in 4.1.5.2.
- 3) Attenuation: Auto (at least 10 dB preferred).
- 4) Sweep time: Coupled.
- 5) Resolution bandwidth: 100 kHz.
- 6) Video bandwidth: 300 kHz.
- 7) Detector: Peak.
- 8) Trace: Max hold.

6.5.3 Test Setup

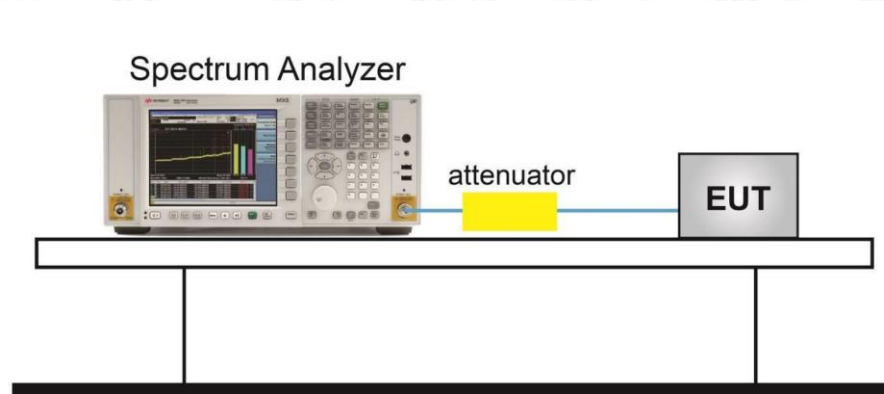

Note: The attenuator shown in the figure is the attenuation of the entire test system.

6.5.4 Measurement Result

TestMode	Antenna	ChName	Frequency[MHz]	RefLevel[dBm]	Result[dBm]	Limit[dBm]	Verdict
BLE_1M	Ant1	Low	2402	-4.60	-44.1	≤-24.6	PASS
BLE_1M	Ant1	High	2480	-4.87	-43.82	≤-24.87	PASS
BLE_2M	Ant1	Low	2402	-4.16	-36.86	≤-24.16	PASS
BLE_2M	Ant1	High	2480	-5.46	-43.87	≤-25.46	PASS

Test Graphs

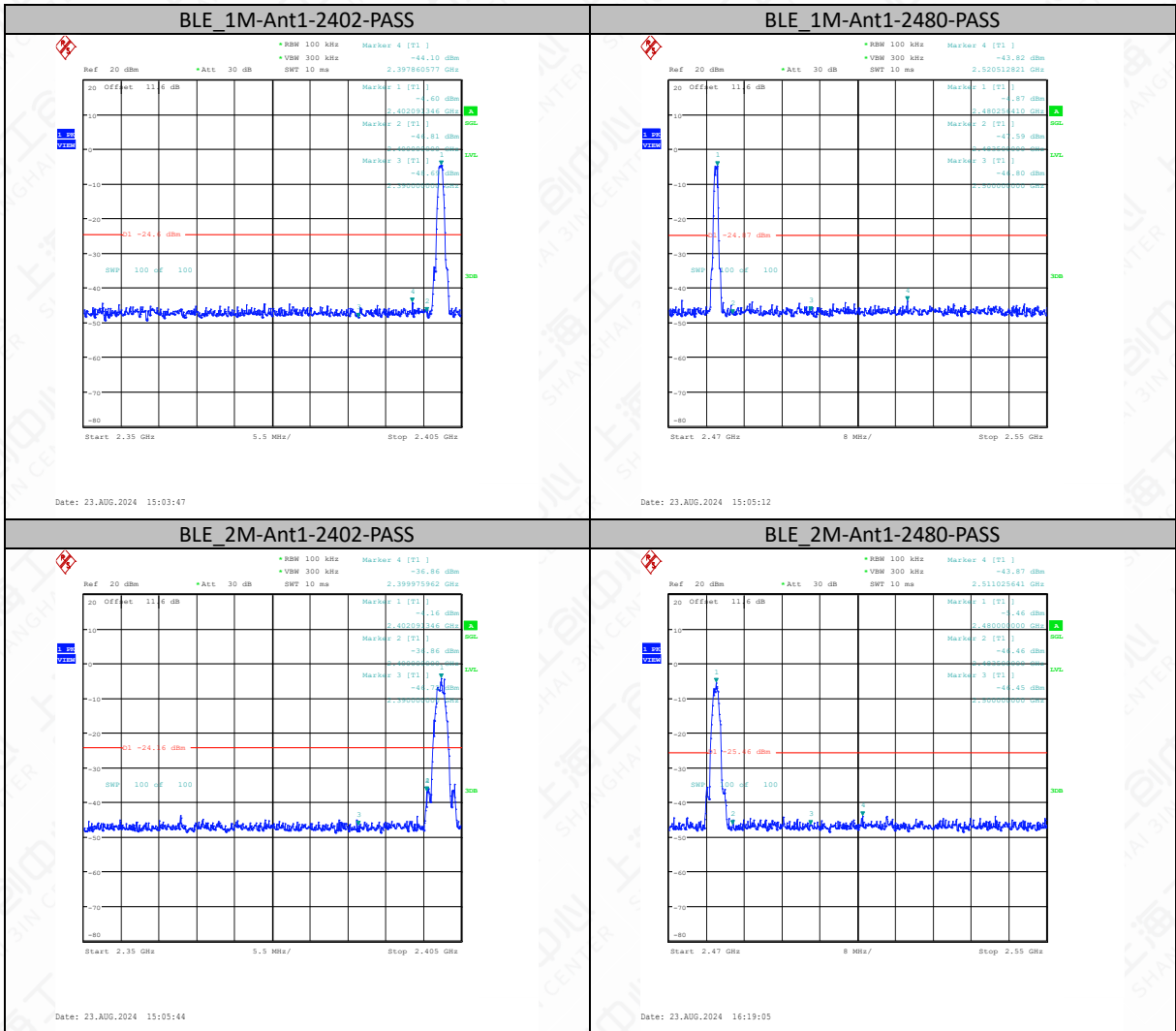

6.6 Conducted Emission

6.6.1 Measurement Limit

Standard	Limit(dBc)
FCC 47 Part 15.247(d)	20dB below peak output power in 100KHz bandwidth
RSS-247 5.5	20dB below peak output power in 100KHz bandwidth

6.6.2 Test procedures

This measurement is according to ANSI C63.10 clause 11.11.

1. The output power of EUT was connected to the spectrum analyzer. The path loss was compensated to the results for each measurement.
2. Enable EUT transmitter maximum power continuously.

Reference level measurement

3. Set instrument center frequency to DTS channel center frequency.
4. Set the span to ≥ 1.5 times the DTS bandwidth.
5. Set the RBW = 100 kHz.
6. Set the VBW $\geq [3 \times \text{RBW}]$.
7. Detector = peak.
8. Sweep time = auto couple.
9. Trace mode = max hold.
10. Allow trace to fully stabilize.
11. Use the peak marker function to determine the maximum PSD level.

Emission level measurement

1. Set the center frequency and span to encompass frequency range to be measured.
2. Set the RBW = 100 kHz.
3. Set the VBW $\geq [3 \times \text{RBW}]$.
4. Detector = peak.
5. Sweep time = auto couple.
6. Trace mode = max hold.
7. Allow trace to fully stabilize.
8. Use the peak marker function to determine the maximum amplitude level.

Note: Not recorded emission from 9 KHz to 30 MHz as emission level at least 20dBc lower than emission limit.

6.6.3 Test Setup

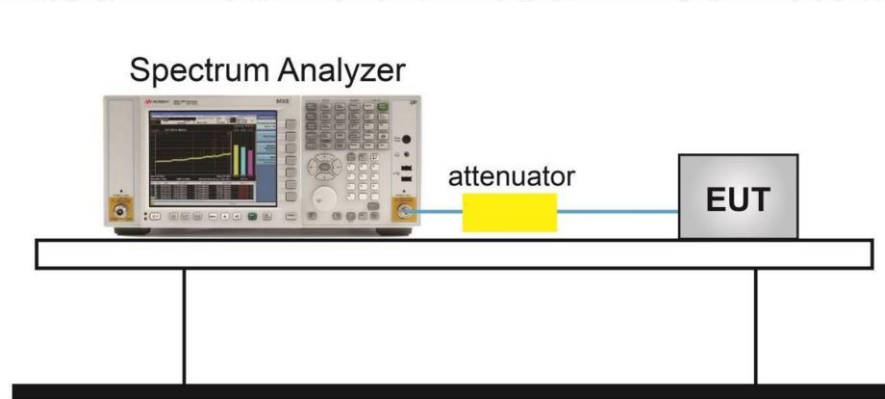

Note: The attenuator shown in the figure is the attenuation of the entire test system.

6.6.4 Measurement Result

TestMode	Antenna	Frequency[MHz]	FreqRange [MHz]	RefLevel [dBm]	Result[dBm]	Limit[dBm]	Verdict
BLE_1M	Ant1	2402	0~Reference	-4.63	-4.63	---	PASS
BLE_1M	Ant1	2402	30~1000	-4.63	-54.93	≤-24.63	PASS
BLE_1M	Ant1	2402	1000~26500	-4.63	-51.04	≤-24.63	PASS
BLE_1M	Ant1	2440	0~Reference	-3.73	-3.73	---	PASS
BLE_1M	Ant1	2440	30~1000	-3.73	-55.33	≤-23.73	PASS
BLE_1M	Ant1	2440	1000~26500	-3.73	-50.81	≤-23.73	PASS
BLE_1M	Ant1	2480	0~Reference	-4.88	-4.88	---	PASS
BLE_1M	Ant1	2480	30~1000	-4.88	-54.96	≤-24.88	PASS
BLE_1M	Ant1	2480	1000~26500	-4.88	-50.85	≤-24.88	PASS
BLE_2M	Ant1	2402	0~Reference	-6.49	-6.49	---	PASS
BLE_2M	Ant1	2402	30~1000	-6.49	-54.7	≤-26.49	PASS
BLE_2M	Ant1	2402	1000~26500	-6.49	-50.66	≤-26.49	PASS
BLE_2M	Ant1	2440	0~Reference	-4.69	-4.69	---	PASS
BLE_2M	Ant1	2440	30~1000	-4.69	-54.91	≤-24.69	PASS
BLE_2M	Ant1	2440	1000~26500	-4.69	-48.94	≤-24.69	PASS
BLE_2M	Ant1	2480	0~Reference	-5.92	-5.92	---	PASS
BLE_2M	Ant1	2480	30~1000	-5.92	-54.52	≤-25.92	PASS
BLE_2M	Ant1	2480	1000~26500	-5.92	-50.38	≤-25.92	PASS

Test Graphs

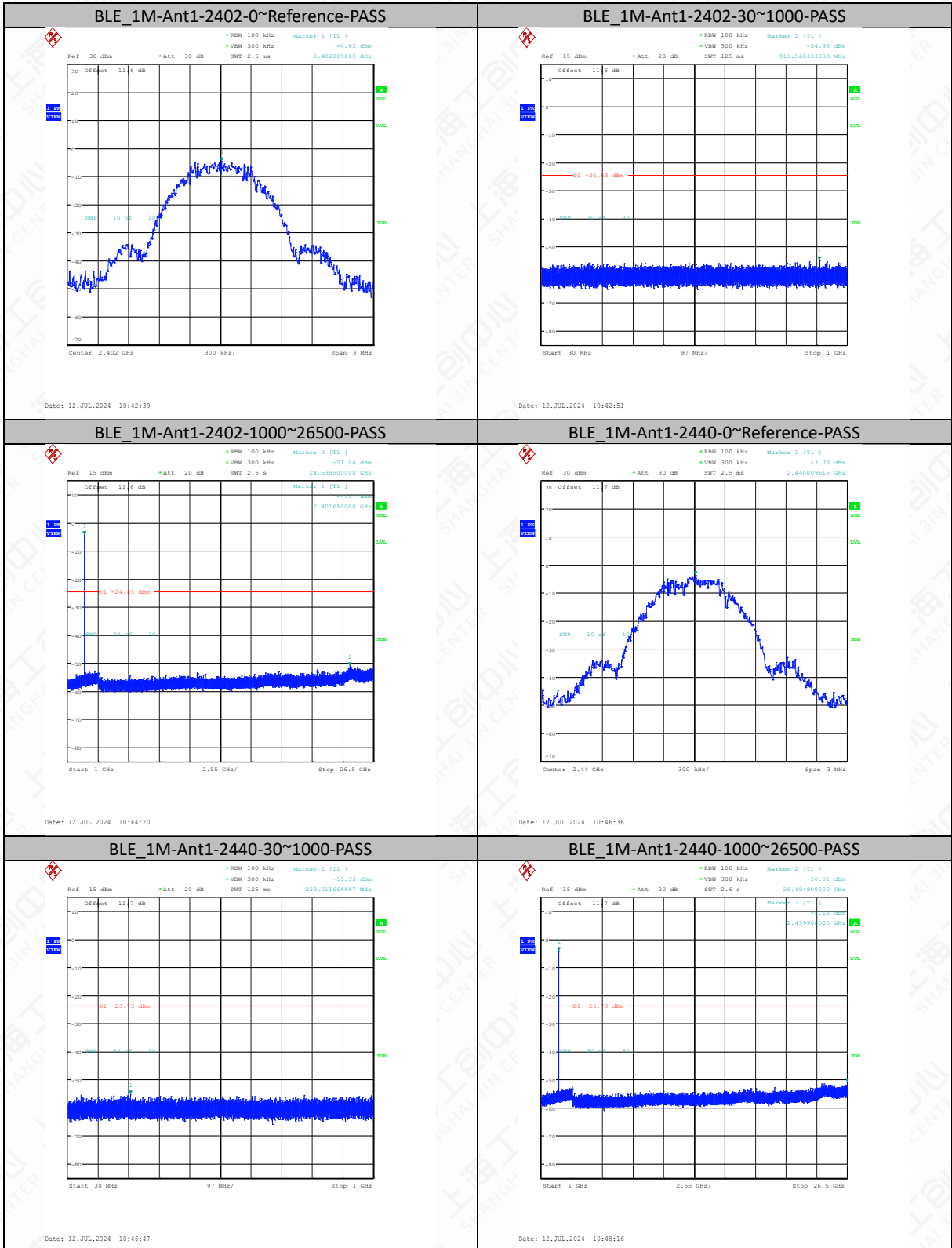

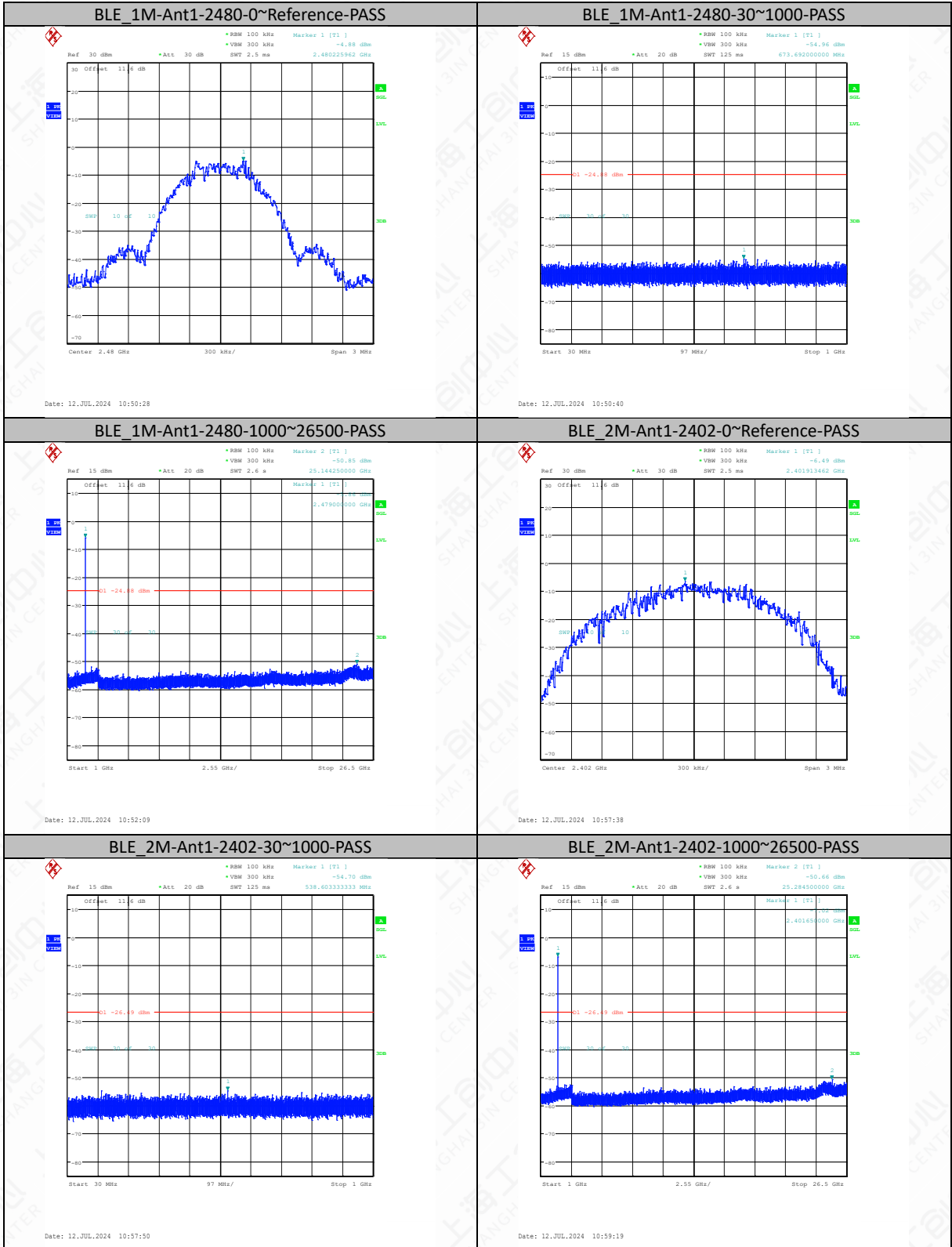

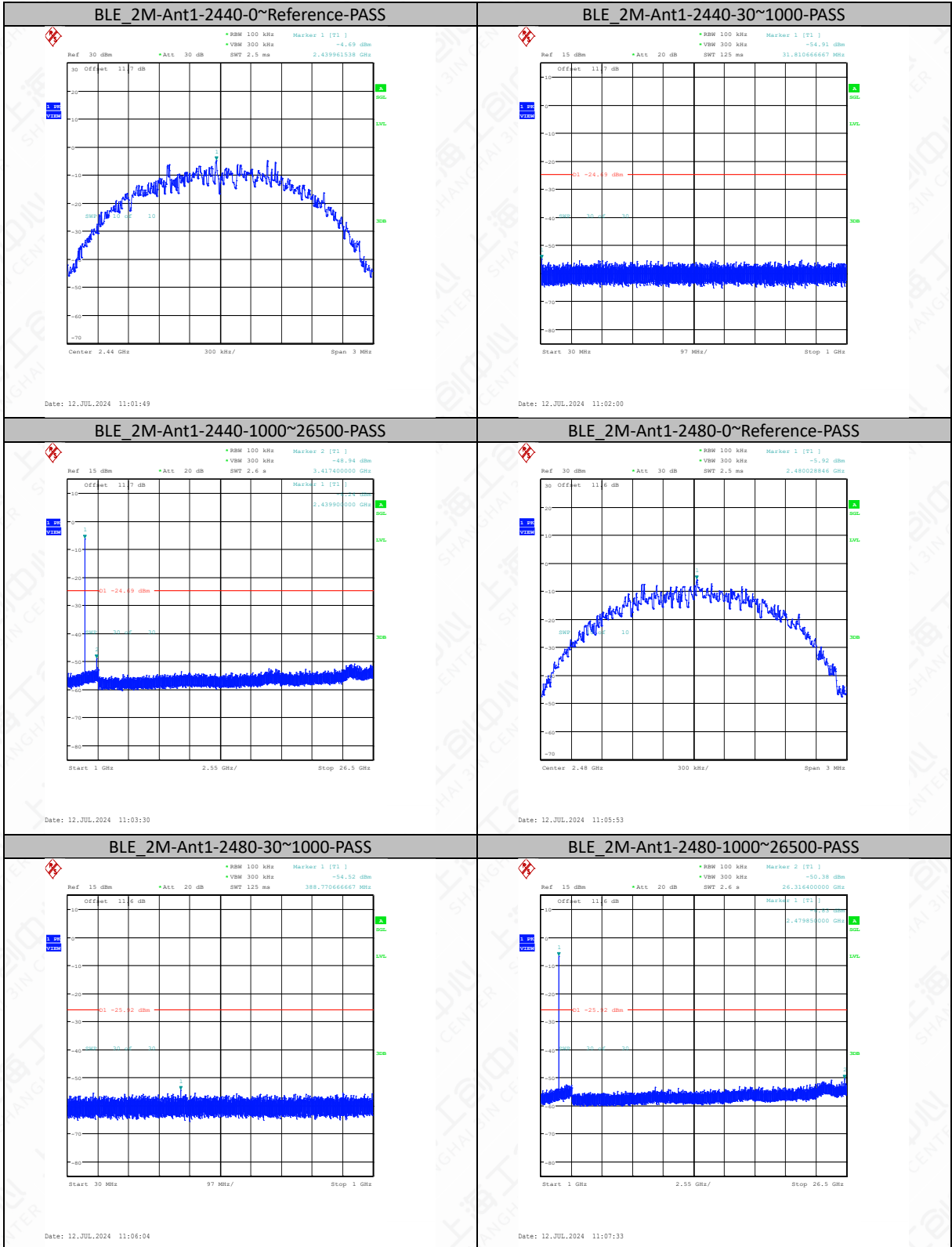

6.7 Radiated Emission

6.7.1 Measurement Limit

According to the FCC 15.205&15.209/RSS-Gen section 8.9&1.0

Limit in restricted band

Frequency of emission (MHz)	Field strength (mV/m)	Field strength (dBuV/m)
0.009~0.49	2400/F (kHz)	129-94
0.49~1.705	24000/F (kHz)	74-63
1.705~30	30	70
30~88	100	40
88~216	150	43.5
216~960	200	46
Above 960	500	54

6.7.2 Test Method

Portable, small, lightweight, or modular devices that may be handheld, worn on the body, or placed on a table during operation shall be positioned on a non-conducting platform, the top of which is 80 cm above the reference ground plane. The preferred area occupied by the EUT arrangement is 1 m by 1.5 m, but it may be larger or smaller to accommodate various sized EUTs. For testing purposes, ceiling- and wall-mounted devices also shall be positioned on a tabletop (see also ANSI C63.10-2013 section 6.3.4 and 6.3.5). In making any tests involving handheld, body-worn, or ceiling-mounted equipment, it is essential to recognize that the measured levels may be dependent on the orientation (attitude) of the three orthogonal axes of the EUT. Thus, exploratory tests as specified in 8.3.1 shall be carried out for various axes orientations to determine the attitude having maximum or near-maximum emission level.

The EUT was placed on a non-conductive table. The measurement antenna was placed at a distance of 3 meters from the EUT. During the tests, the antenna height and the EUT azimuth were varied in order to identify the maximum level of emissions from the EUT. This maximization process was repeated with the EUT positioned in each of its three orthogonal orientations.

Test Settings – Below 1GHz (Quasi-Peak Field Strength Measurements)

1. Set the center frequency and span to encompass frequency range to be measured.
2. Set the RBW = 100 kHz.
3. Set the VBW = 300 kHz.
4. Detector = quasi-peak.
5. Sweep time = auto couple.
6. Trace mode = max hold.
7. Trace was allowed to stabilize.

Test Settings – Above 1GHz (Peak Field Strength Measurements)

1. Set the center frequency and span to encompass frequency range to be measured.
2. Set the RBW = 1MHz.
3. Set the VBW = 3MHz.
4. Detector = peak
5. Trace mode = max hold

6. Sweep time = auto
7. Trace (RMS) averaging was performed over at least 100 traces.

Test Settings – Above 1GHz (Average Field Strength Measurements)

1. Set the center frequency and span to encompass frequency range to be measured.
2. Set the RBW = 1MHz.
3. Set the VBW = 3MHz.
4. Detector = power average (RMS).
5. Number of measurement points = 1001 (Number of points must be $\geq 2 \times \text{span} \setminus \setminus \text{RBW}$)
6. Sweep time = auto
7. Trace (RMS) averaging was performed over at least 100 traces.

Frequency of emission (MHz)	RBW/VBW	Sweep Time (s)
0.009~30	9KHz/30KHz	Auto
30~1000	100KHz/300KHz	5
1000~4000	1MHz/3MHz	15
4000~18000	1MHz/3MHz	40
18000~26500	1MHz/3MHz	20

6.7.3 Test Setup

Below 30MHz Test Setup

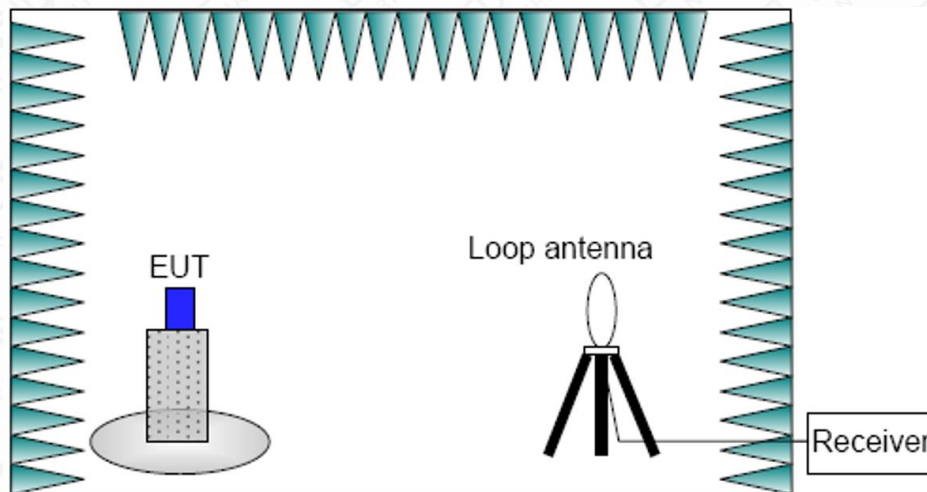

Below 1GHz Test Setup

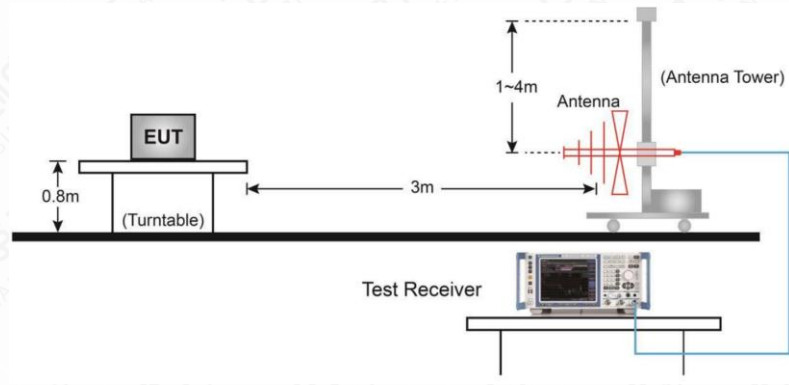

Above 1GHz Test Setup

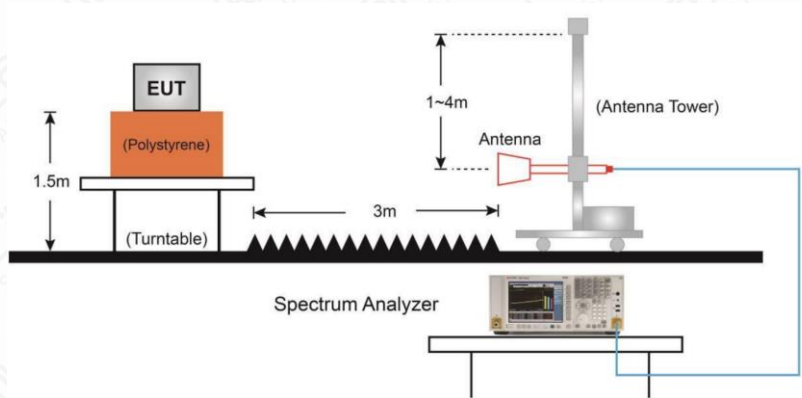

6.7.4 Measurement Results

A “reference path loss” is established and AR_{pi} is the attenuation of “reference path loss”, and including the gain of receive antenna, the gain of the preamplifier, the cable loss.

The measurement results are obtained as described below:

$$A_{Rpi} = \text{Cable loss} + \text{Antenna Factor} - \text{Preamplifier gain}$$

$$\text{Result} = P_{\text{Mea}} + A_{Rpi}$$

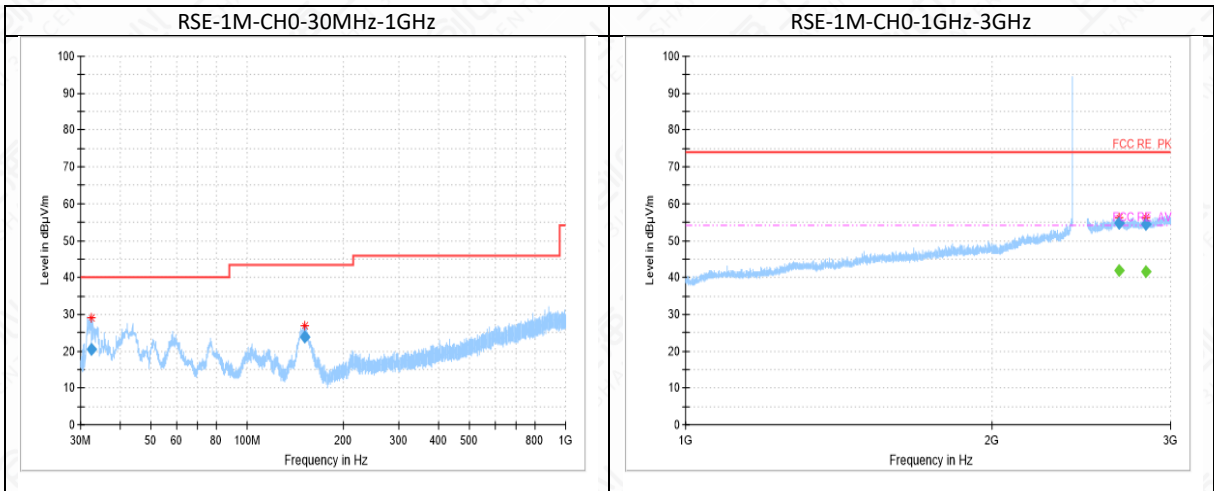

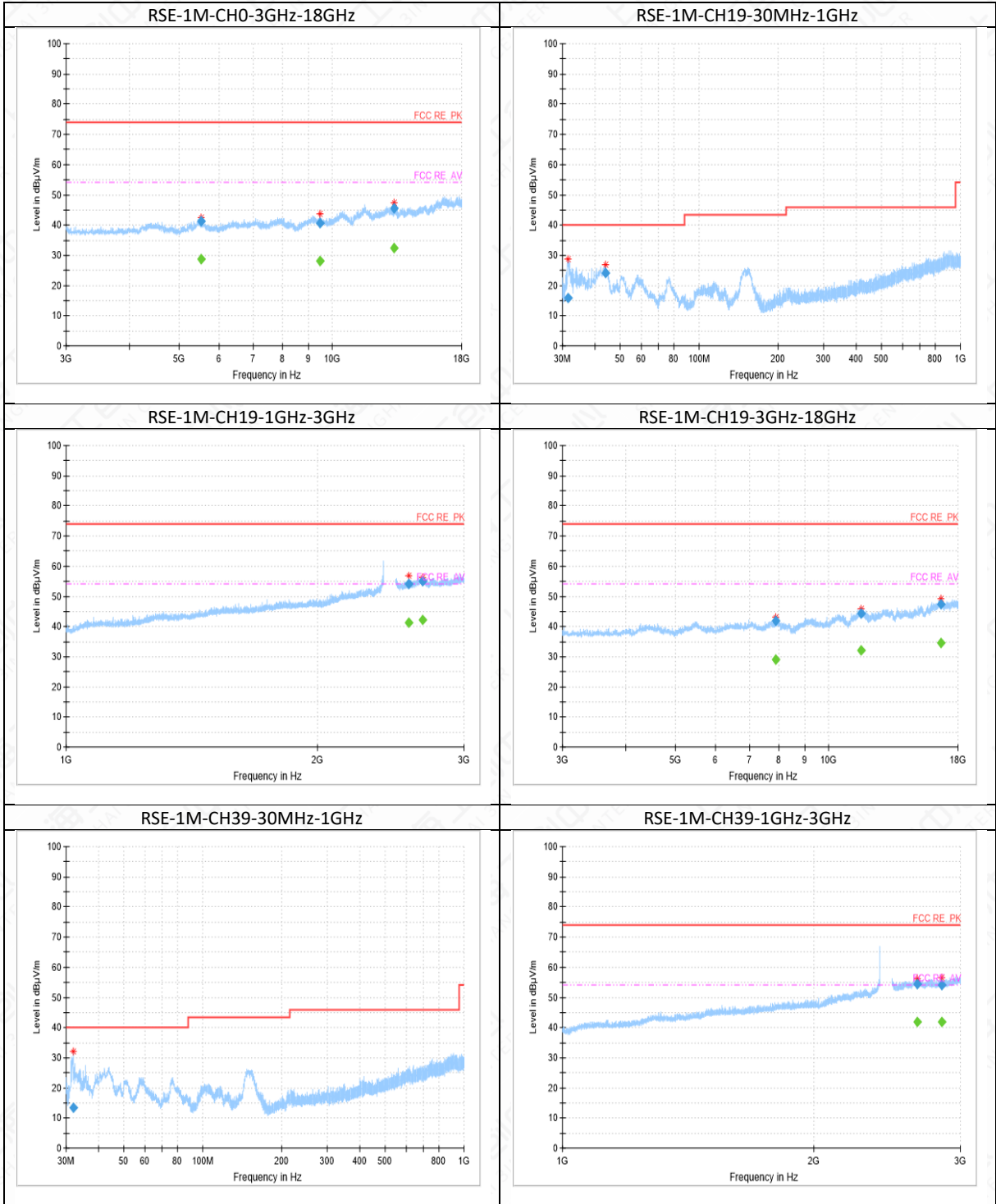

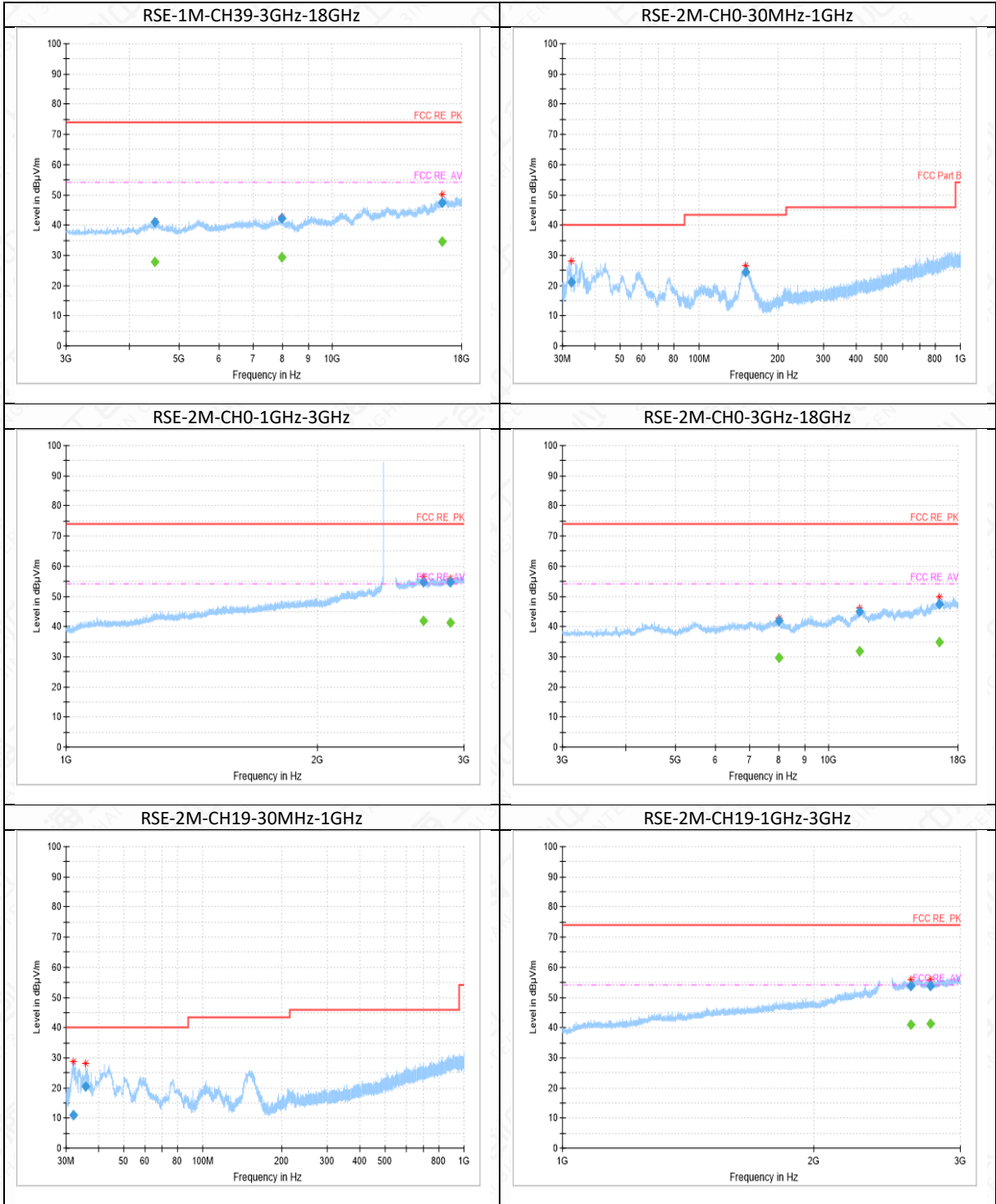

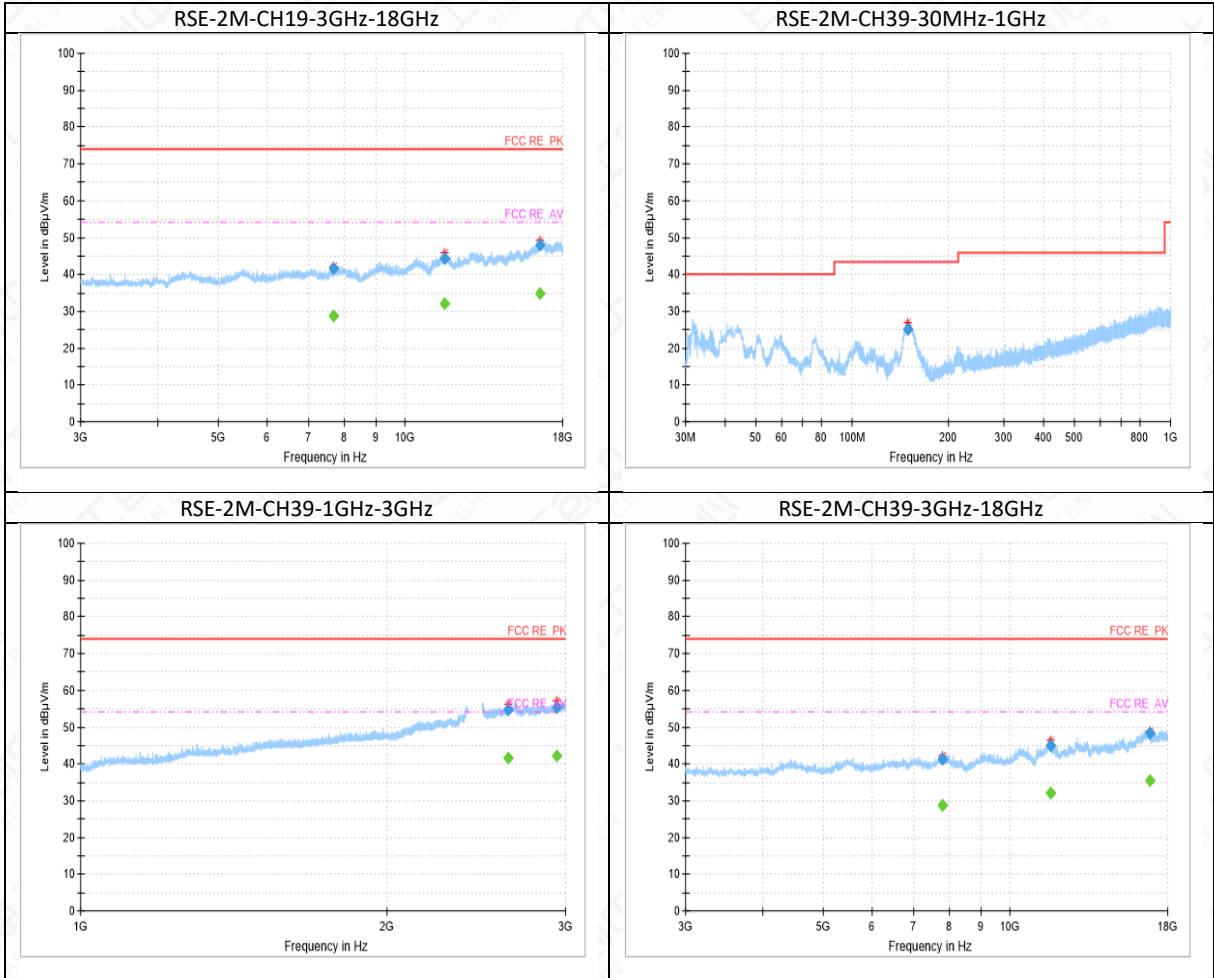

Bandedge

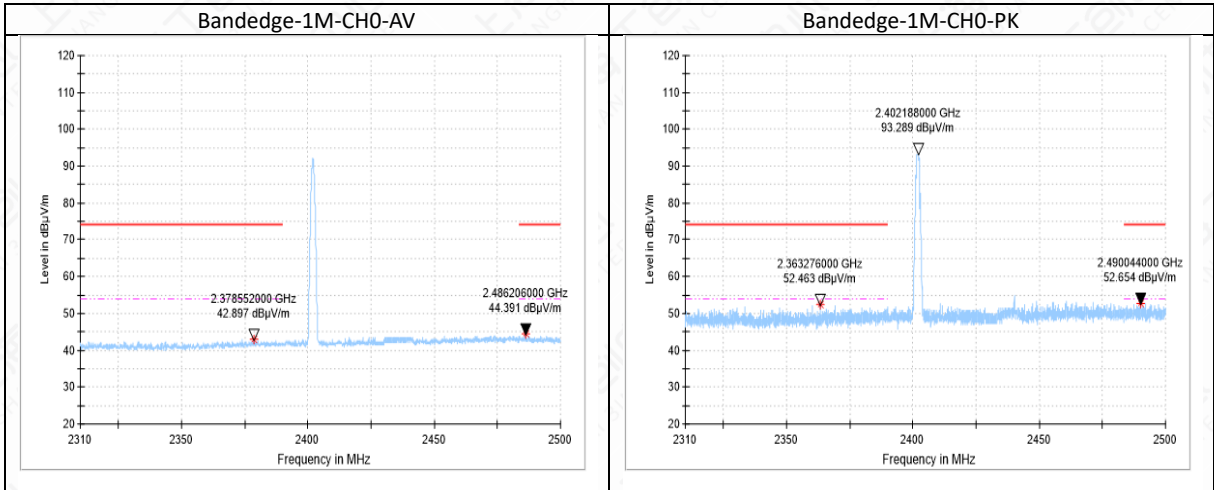

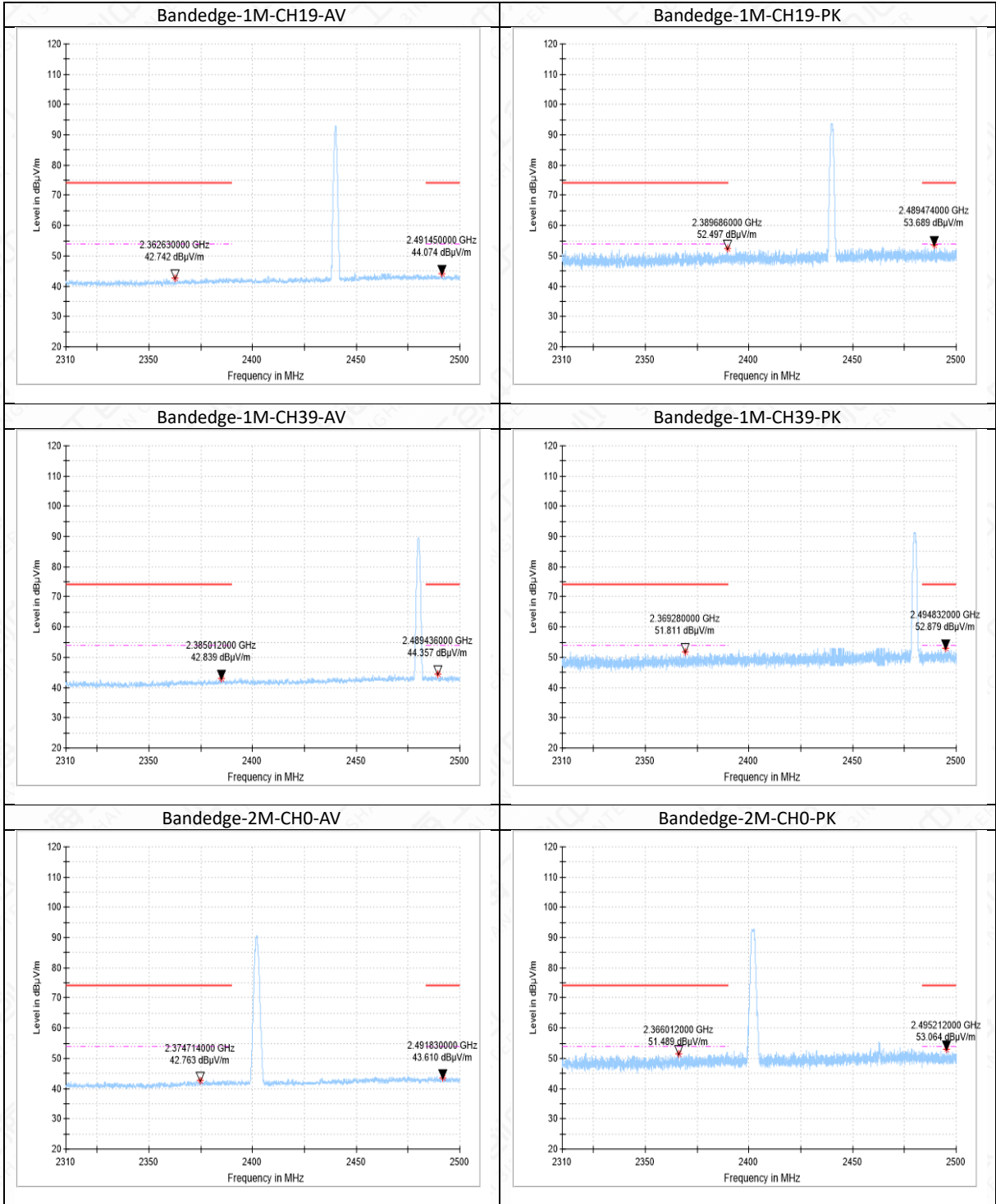

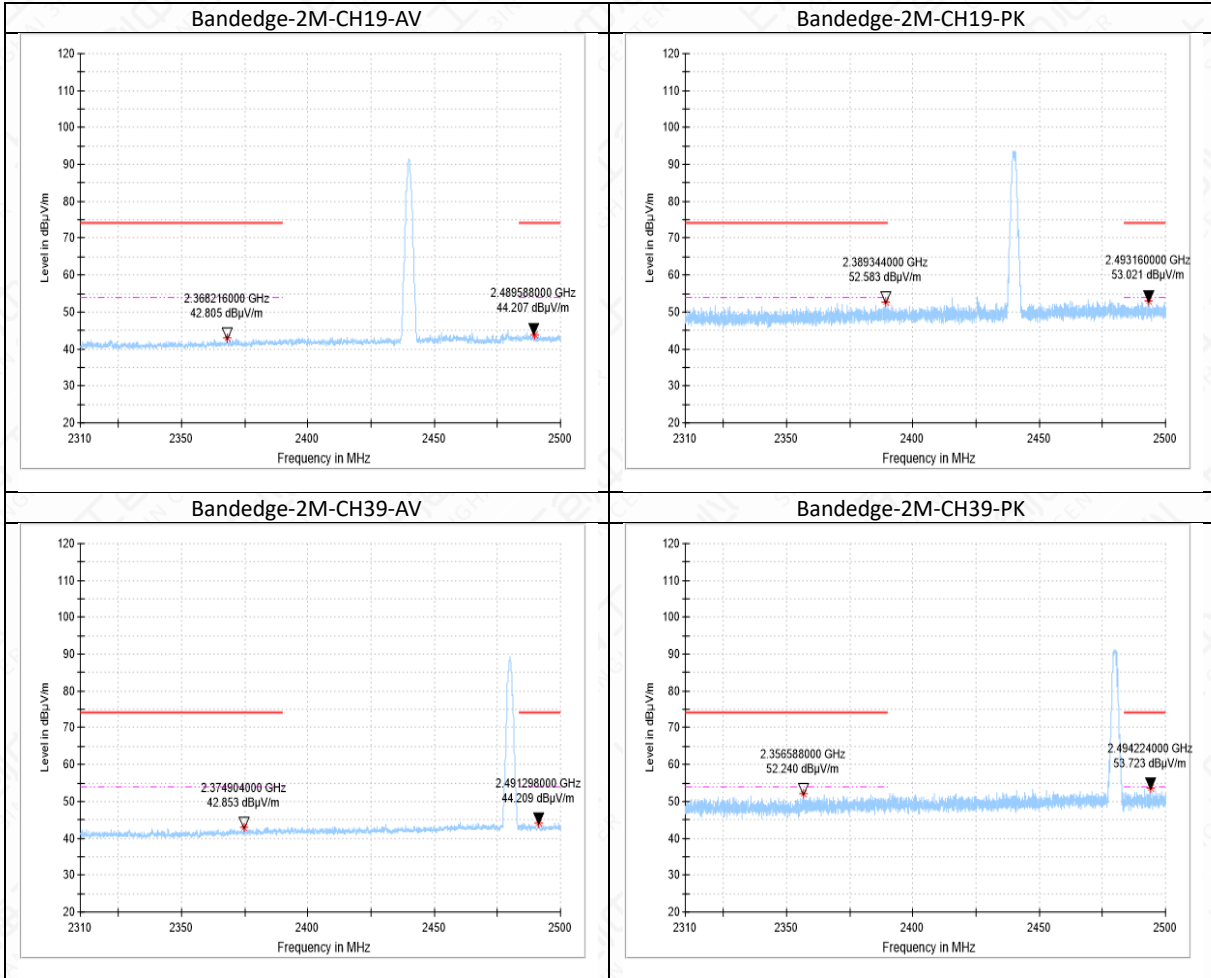
RSE-1M-CH0-30MHz-1GHz

Frequency (MHz)	QuasiPeak(dBµV/m)	ARpl (dB)	PMea (dBµV/m)	Margin(dB)	Limit(dBµV/m)	Polarity
32.4	20.43	-15	35.43	19.57	40.00	V
151.5	23.9	-16	39.9	19.60	43.50	H

RSE-1M-CH0-1GHz-3GHz

Frequency (MHz)	MaxPeak(dBµV/m)	ARpl (dB)	PMea (dBµV/m)	Margin(dB)	Limit(dBµV/m)	Polarity
2668.1	54.64	18	36.64	19.36	74.00	H
2838.3	54.34	17	37.34	19.66	74.00	H

RSE-1M-CH0-1GHz-3GHz

Frequency (MHz)	Average(dBµV/m)	ARpl (dB)	PMea (dBµV/m)	Margin(dB)	Limit(dBµV/m)	Polarity
2668.1	42.01	18	24.01	11.99	54.00	H
2838.3	41.74	17	24.74	12.26	54.00	H

RSE-1M-CH0-3GHz-18GHz

Frequency (MHz)	MaxPeak(dBµV/m)	ARpl (dB)	PMea (dBµV/m)	Margin(dB)	Limit(dBµV/m)	Polarity
5541.6	41.3	-3	44.3	32.70	74.00	V

9461.2	40.62	0	40.62	33.38	74.00	H
13278.8	45.51	4	41.51	28.49	74.00	V

RSE-1M-CH0-3GHz-18GHz

Frequency (MHz)	Average(dBμV/m)	ARpl (dB)	PMea (dBμV/m)	Margin(dB)	Limit(dBμV/m)	Polarity
5541.6	28.9	-3	31.9	25.10	54.00	V
9461.2	28.01	0	28.01	25.99	54.00	H
13278.8	32.51	4	28.51	21.49	54.00	V

RSE-1M-CH19-30MHz-1GHz

Frequency (MHz)	QuasiPeak(dBμV/m)	ARpl (dB)	PMea (dBμV/m)	Margin(dB)	Limit(dBμV/m)	Polarity
31.6	16.03	-16	32.03	23.97	40.00	V
43.8	24.09	-12	36.09	15.91	40.00	V

RSE-1M-CH19-1GHz-3GHz

Frequency (MHz)	MaxPeak(dBμV/m)	ARpl (dB)	PMea (dBμV/m)	Margin(dB)	Limit(dBμV/m)	Polarity
2574.2	54.27	17	37.27	19.73	74.00	H
2676.9	55.19	17	38.19	18.81	74.00	V

RSE-1M-CH19-1GHz-3GHz

Frequency (MHz)	Average(dBμV/m)	ARpl (dB)	PMea (dBμV/m)	Margin(dB)	Limit(dBμV/m)	Polarity
2574.2	41.41	17	24.41	12.59	54.00	H
2676.9	42.09	17	25.09	11.91	54.00	V

RSE-1M-CH19-3GHz-18GHz

Frequency (MHz)	MaxPeak(dBμV/m)	ARpl (dB)	PMea (dBμV/m)	Margin(dB)	Limit(dBμV/m)	Polarity
7877.9	41.87	-2	43.87	32.13	74.00	V
11622.1	44.39	4	40.39	29.61	74.00	V
16654.8	47.47	10	37.47	26.53	74.00	H

RSE-1M-CH19-3GHz-18GHz

Frequency (MHz)	Average(dBμV/m)	ARpl (dB)	PMea (dBμV/m)	Margin(dB)	Limit(dBμV/m)	Polarity
7877.9	29.16	-2	31.16	24.84	54.00	V
11622.1	32.04	4	28.04	21.96	54.00	V
16654.8	34.56	10	24.56	19.44	54.00	H

RSE-1M-CH39-30MHz-1GHz

Frequency (MHz)	QuasiPeak(dBμV/m)	ARpl (dB)	PMea (dBμV/m)	Margin(dB)	Limit(dBμV/m)	Polarity
31.9	13.59	-15	28.59	26.41	40.00	V

RSE-1M-CH39-1GHz-3GHz

Frequency (MHz)	MaxPeak(dBμV/m)	ARpl (dB)	PMea (dBμV/m)	Margin(dB)	Limit(dBμV/m)	Polarity
2662.5	54.58	18	36.58	19.42	74.00	V
2852.0	54.22	18	36.22	19.78	74.00	H

RSE-1M-CH39-1GHz-3GHz

Frequency (MHz)	Average(dBμV/m)	ARpl (dB)	PMea (dBμV/m)	Margin(dB)	Limit(dBμV/m)	Polarity
2662.5	41.89	18	23.89	12.11	54.00	V
2852.0	41.78	18	23.78	12.22	54.00	H

RSE-1M-CH39-3GHz-18GHz

Frequency (MHz)	MaxPeak(dBμV/m)	ARpl (dB)	PMea (dBμV/m)	Margin(dB)	Limit(dBμV/m)	Polarity
4483.1	40.97	-4	44.97	33.03	74.00	V
7964.5	42.27	-1	43.27	31.73	74.00	V
16466.2	47.4	10	37.4	26.60	74.00	V

RSE-1M-CH39-3GHz-18GHz

Frequency (MHz)	Average(dBμV/m)	ARpl (dB)	PMea (dBμV/m)	Margin(dB)	Limit(dBμV/m)	Polarity
4483.1	27.96	-4	31.96	26.04	54.00	V
7964.5	29.38	-1	30.38	24.62	54.00	V
16466.2	34.52	10	24.52	19.48	54.00	V

RSE-2M-CH0-30MHz-1GHz

Frequency (MHz)	QuasiPeak(dBμV/m)	ARpl (dB)	PMea (dBμV/m)	Margin(dB)	Limit(dBμV/m)	Polarity
32.4	21.09	-15	36.09	18.91	40.00	V
150.2	24.57	-16	40.57	18.93	43.50	H

RSE-2M-CH0-1GHz-3GHz

Frequency (MHz)	MaxPeak(dBμV/m)	ARpl (dB)	PMea (dBμV/m)	Margin(dB)	Limit(dBμV/m)	Polarity
2679.6	54.79	17	37.79	19.21	74.00	V
2884.4	54.7	17	37.7	19.30	74.00	H

RSE-2M-CH0-1GHz-3GHz

Frequency (MHz)	Average(dBμV/m)	ARpl (dB)	PMea (dBμV/m)	Margin(dB)	Limit(dBμV/m)	Polarity
2679.6	42.01	17	25.01	11.99	54.00	V
2884.4	41.42	17	24.42	12.58	54.00	H

RSE-2M-CH0-3GHz-18GHz

Frequency (MHz)	MaxPeak(dBμV/m)	ARpl (dB)	PMea (dBμV/m)	Margin(dB)	Limit(dBμV/m)	Polarity
7991.8	42	-1	43	32.00	74.00	V
11530.2	44.89	3	41.89	29.11	74.00	H
16545.0	47.45	10	37.45	26.55	74.00	H

RSE-2M-CH0-3GHz-18GHz

Frequency (MHz)	Average(dBμV/m)	ARpl (dB)	PMea (dBμV/m)	Margin(dB)	Limit(dBμV/m)	Polarity
7991.8	29.52	-1	30.52	24.48	54.00	V
11530.2	31.93	3	28.93	22.07	54.00	H
16545.0	34.75	10	24.75	19.25	54.00	H

RSE-2M-CH19-30MHz-1GHz

Frequency (MHz)	QuasiPeak(dBμV/m)	ARpl (dB)	PMea (dBμV/m)	Margin(dB)	Limit(dBμV/m)	Polarity
32.1	11.03	-15	26.03	28.97	40.00	V
35.7	20.41	-14	34.41	19.59	40.00	V

RSE-2M-CH19-1GHz-3GHz

Frequency (MHz)	MaxPeak(dBμV/m)	ARpl (dB)	PMea (dBμV/m)	Margin(dB)	Limit(dBμV/m)	Polarity
2612.9	53.91	17	36.91	20.09	74.00	H
2761.8	53.73	17	36.73	20.27	74.00	H

RSE-2M-CH19-1GHz-3GHz

Frequency (MHz)	Average(dBμV/m)	ARpl (dB)	PMea (dBμV/m)	Margin(dB)	Limit(dBμV/m)	Polarity
2612.9	41.06	17	24.06	12.94	54.00	H
2761.8	41.33	17	24.33	12.67	54.00	H

RSE-2M-CH19-3GHz-18GHz

Frequency (MHz)	MaxPeak(dBμV/m)	ARpl (dB)	PMea (dBμV/m)	Margin(dB)	Limit(dBμV/m)	Polarity
7684.2	41.66	-1	42.66	32.34	74.00	V
11625.0	44.44	4	40.44	29.56	74.00	V
16547.4	47.88	10	37.88	26.12	74.00	V

RSE-2M-CH19-3GHz-18GHz

Frequency (MHz)	Average(dBμV/m)	ARpl (dB)	PMea (dBμV/m)	Margin(dB)	Limit(dBμV/m)	Polarity
7684.2	28.88	-1	29.88	25.12	54.00	V
11625.0	32.24	4	28.24	21.76	54.00	V
16547.4	34.81	10	24.81	19.19	54.00	V

RSE-2M-CH39-30MHz-1GHz

Frequency (MHz)	QuasiPeak(dBμV/m)	ARpl (dB)	PMea (dBμV/m)	Margin(dB)	Limit(dBμV/m)	Polarity
149.7	25.14	-16	41.14	18.36	43.50	H

RSE-2M-CH39-1GHz-3GHz

Frequency (MHz)	MaxPeak(dBμV/m)	ARpl (dB)	PMea (dBμV/m)	Margin(dB)	Limit(dBμV/m)	Polarity
2633.3	54.78	17	37.78	19.22	74.00	V
2939.8	55.21	18	37.21	18.79	74.00	H

RSE-2M-CH39-1GHz-3GHz

Frequency (MHz)	Average(dBμV/m)	ARpl (dB)	PMea (dBμV/m)	Margin(dB)	Limit(dBμV/m)	Polarity
2633.3	41.62	17	24.62	12.38	54.00	V
2939.8	42.2	18	24.2	11.80	54.00	H

RSE-2M-CH39-3GHz-18GHz

Frequency (MHz)	MaxPeak(dBμV/m)	ARpl (dB)	PMea (dBμV/m)	Margin(dB)	Limit(dBμV/m)	Polarity
7789.2	41.13	-2	43.13	32.87	74.00	H
11659.8	45.1	3	42.1	28.90	74.00	V
16840.2	48.3	10	38.3	25.70	74.00	H

RSE-2M-CH39-3GHz-18GHz

Frequency (MHz)	Average(dBμV/m)	ARpl (dB)	PMea (dBμV/m)	Margin(dB)	Limit(dBμV/m)	Polarity
7789.2	28.85	-2	30.85	25.15	54.00	H
11659.8	32.01	3	29.01	21.99	54.00	V
16840.2	35.57	10	25.57	18.43	54.00	H

Note:

1. The out-of- limit signal in the picture is the main frequency signal.
2. Only data in worst mode is provided.
3. Sweep the whole frequency band through the range from 30MHz to the 10th harmonic of the carrier, the Emissions in the frequency band 18GHz-26.5GHz is more than 20dB below the limit are not report.
4. The test data below 30MHz is more than 20dB lower than the limit value, so it is not provided in the report.

6.8 AC Powerline Conducted Emission

6.8.1 Method of Measurement: ANSI C63.10-2013-clause 6.2

1. The one EUT cable configuration and arrangement and mode of operation that produced the emission with the highest amplitude relative to the limit is selected for the final measurement, while applying the appropriate modulating signal to the EUT.
2. If the EUT is relocated from an exploratory test site to a final test site, the highest emissions shall be remaximized at the final test location before final ac power-line conducted emission measurements are performed.
3. The final test on all current-carrying conductors of all of the power cords to the equipment that comprises the EUT (but not the cords associated with other non-EUT equipment in the system) is then performed for the full frequency range for which the EUT is being tested for compliance without further variation of the EUT arrangement, cable positions, or EUT mode of operation.
4. If the EUT is comprised of equipment units that have their own separate ac power connections, e.g., floor-standing equipment with independent power cords for each shelf that are able to connect directly to the ac power network, each current-carrying conductor of one unit is measured while the other units are connected to a second (or more) LISN(s). All units shall be separately measured. If a power strip is provided by the manufacturer, to supply all of the units making up the EUT, only the conductors in the power cord of the power strip shall be measured.

If the EUT uses a detachable antenna, these measurements shall be made with a suitable dummy load connected to the antenna output terminals; otherwise, the tests shall be made with the antenna connected and, if adjustable, fully extended. When measuring the ac conducted emissions from a device that operates between 150 kHz and 30 MHz a non-detachable antenna may be replaced with a dummy load for the measurements within the fundamental emission band of the transmitter, but only for those measurements.³⁶ Record the six highest EUT emissions relative to the limit of each of the current-carrying conductors of the power cords of the equipment that comprises the EUT over the frequency range specified by the procuring or regulatory agency. Diagram or photograph the test setup that was used. See Clause 8 for full reporting requirements.

6.8.2 Test Setup

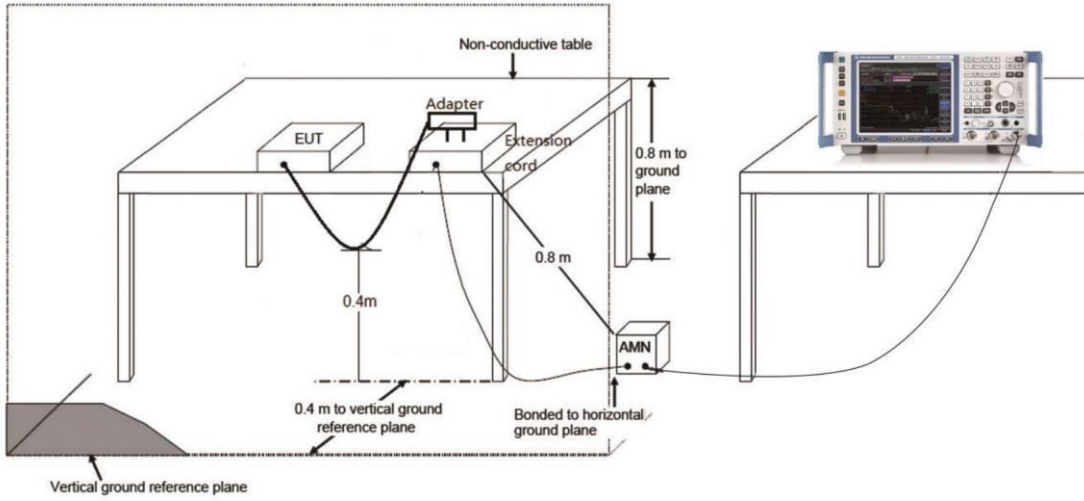

6.8.3 Test Condition

Voltage (V)	Frequency (Hz)
120	60

6.8.4 Measurement limit

(Quasi-peak-average Limit)

Frequency range (MHz)	Quasi-peak Limit (dB μ V)	Average Limit (dB μ V)	Conclusion
0.15 to 0.5	66 to 56	56 to 46	P
0.5 to 5	56	46	
5 to 30	60	50	

NOTE: The limit decreases linearly with the logarithm of the frequency in the range 0.15 MHz to 0.5 MHz.

6.8.5 Measurement Result

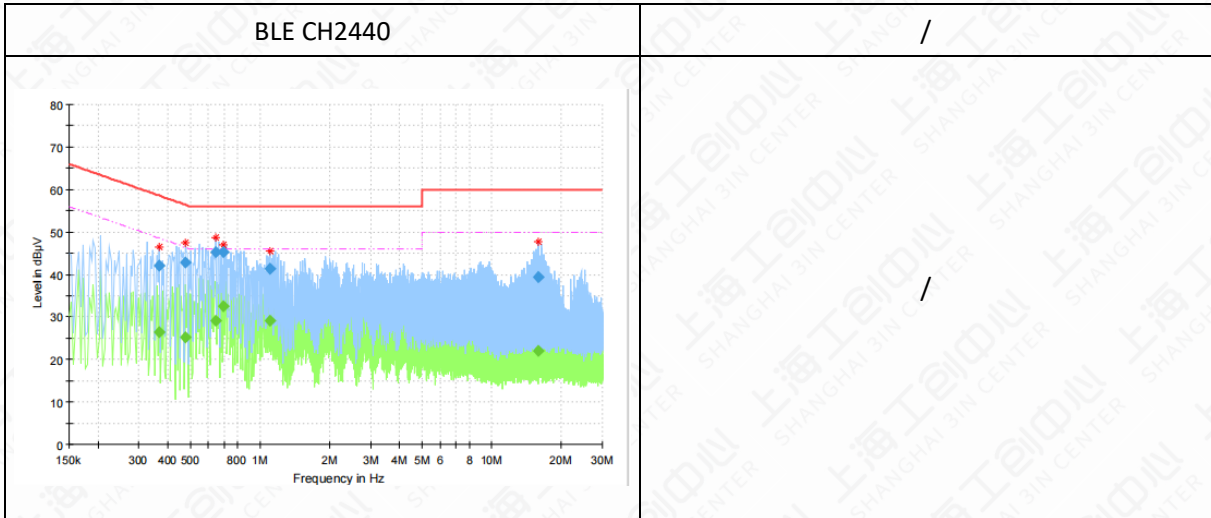

Frequency (MHz)	QuasiPeak (dBµV)	Average (dBµV)	Limit (dBµV)	Margin (dB)	Meas. Time (ms)	Bandwidth (kHz)	Line	Filter	Corr. (dB)
0.366413	42.16	---	58.58	16.42	15000.0	9.000	N	ON	10.5
0.366413	---	26.44	48.58	22.14	15000.0	9.000	N	ON	10.5
0.478350	---	25.16	46.37	21.21	15000.0	9.000	N	ON	10.5
0.478350	42.76	---	56.37	13.61	15000.0	9.000	N	ON	10.5
0.646256	45.25	---	56.00	10.75	15000.0	9.000	L1	ON	9.8
0.646256	---	29.04	46.00	16.96	15000.0	9.000	L1	ON	9.8
0.694763	---	32.49	46.00	13.51	15000.0	9.000	N	ON	10.5
0.694763	45.26	---	56.00	10.74	15000.0	9.000	N	ON	10.5
1.108931	---	29.16	46.00	16.84	15000.0	9.000	N	ON	10.5
1.108931	41.26	---	56.00	14.74	15000.0	9.000	N	ON	10.5
15.791400	---	22.07	50.00	27.93	15000.0	9.000	N	ON	12.7
15.791400	39.46	---	60.00	20.54	15000.0	9.000	N	ON	12.7

Note:

1. All modes have been tested and only the worst mode is recorded in the report.
2. L1 and N is all have been tested, the result of them is synthesized in the above data diagram.

Annex A: Revised History

Version	Revised Content
V0	Initial

Annex B: Accreditation Certificate

Accredited Laboratory

A2LA has accredited

INDUSTRIAL INTERNET INNOVATION CENTER (SHANGHAI) CO., LTD.

Shanghai, People's Republic of China

for technical competence in the field of

Electrical Testing

This laboratory is accredited in accordance with the recognized International Standard ISO/IEC 17025:2017 *General requirements for the competence of testing and calibration laboratories*. This accreditation demonstrates technical competence for a defined scope and the operation of a laboratory quality management system (refer to joint ISO-ILAC-IAF Communiqué dated April 2017).



Presented this 20th day of September 2023.



Mr. Trace McInturff, Vice President, Accreditation Services
For the Accreditation Council
Certificate Number 3682.01
Valid to February 28, 2025

For the tests to which this accreditation applies, please refer to the laboratory's Electrical Scope of Accreditation.

END OF REPORT