



TEST REPORT

No. I19D00121-EMC01

For

Client : Shanghai Sunmi Technology Co.,Ltd.

Production : Smart POS system

Model Name : T6900

Brand Name: SUNMI

FCC ID: 2AH25T6900

Hardware Version: B1691_MAIN_PCB

Software Version: V1.0.1

Issued date: 2019-08-26

NOTE

1. The test results in this test report relate only to the devices specified in this report.
2. This report shall not be reproduced except in full without the written approval of East China Institute of Telecommunications
3. The measurement uncertainty is not taken into account when deciding conformity, and the results of measurement (or the average of measurement results) are directly used as the criterion for the stating conformity.

Test Laboratory:

East China Institute of Telecommunications

Add: 7-8F, G Area, No.668, Beijing East Road, Huangpu District, Shanghai, P. R. China

Tel: +862163843300

FAX: +862163843301

E-Mail: welcome@ecit.org.cn

Revision Version

Report Number	Revision	Date	Memo
I19D00121-EMC01	00	2019-08-26	Initial creation of test report

CONTENTS

1. TEST LABORATORY	6
1.1. TESTING LOCATION	6
1.2. TESTING ENVIRONMENT	6
1.3. PROJECT DATA.....	6
1.4. SIGNATURE.....	6
2. CLIENT INFORMATION	7
2.1. APPLICANT INFORMATION.....	7
2.2. MANUFACTURER INFORMATION.....	7
3. EQUIPMENT UNDER TEST (EUT) AND ANCILLARY EQUIPMENT (AE)	8
3.1. ABOUT EUT.....	8
3.2. INTERNAL IDENTIFICATION OF EUT USED DURING THE TEST	8
3.3. INTERNAL IDENTIFICATION OF AE USED DURING THE TEST	8
4. REFERENCE DOCUMENTS.....	9
4.1 REFERENCE DOCUMENTS FOR TESTING.....	9
5. TEST RESULTS.....	10
5.1 SUMMARY OF TEST RESULTS	10
5.2 STATEMENTS.....	10
6. TEST EQUIPMENT UTILIZED	11
6.1 RADIATED EMISSION EQUIPMENT LIST	11
6.1 AC CONDUCTED EMISSION EQUIPMENT LIST	11
7. SYSTEM CONFIGURATION DURING TEST.....	12
7.1 TEST MODE.....	12
7.2 CONNECTION DIAGRAM OF TEST SYSTEM.....	13
8. MEASUREMENT RESULTS.....	14
8.1 RADIATED EMISSION 30MHZ-18GHZ.....	14

8.2 AC CONDUCTED EMISSION..... 21

1. Test Laboratory

1.1. Testing Location

Company Name:	ECIT Shanghai, East China Institute of Telecommunications
Address:	7-8F, G Area, No. 668, Beijing East Road, Huangpu District, Shanghai, P. R. China
Postal Code:	200001
Telephone:	(+86)-021-63843300
Fax:	(+86)-021-63843301
FCC registration No:	958356

1.2. Testing Environment

Normal Temperature:	15-35°C
Relative Humidity:	30-60% RH
Supply Voltage	120V/60Hz

1.3. Project data

Project Leader:	Chen Minfei
Testing Start Date:	2019-08-02
Testing End Date:	2019-08-16

1.4. Signature

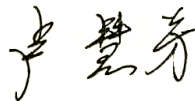

Lu Huifang
(Prepared this test report)



You Jinjun
(Reviewed this test report)

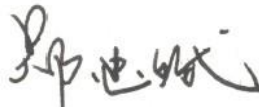

Zheng Zhongbin
(Approved this test report)

2. Client Information

2.1. Applicant Information

Company Name	Shanghai Sunmi Technology Co.,Ltd.
Address	Room 605, Block 7, KIC Plaza, No.388 Song Hu Road, Yang Pu District, Shanghai, China
Telephone	86-18721763396
Postcode	/

2.2. Manufacturer Information

Company Name	Shanghai Sunmi Technology Co.,Ltd.
Address	Room 605, Block 7, KIC Plaza, No.388 Song Hu Road, Yang Pu District, Shanghai, China
Telephone	86-18721763396
Postcode	/

3. Equipment under Test (EUT) and Ancillary Equipment (AE)

3.1. About EUT

Product Name	Smart POS system
Model name	T6900
GSM Frequency Band	GSM850/GSM900/GSM1800/GSM1900
UMTS Frequency Band	Band I /Band II /BandIV/Band V /BandVIII
LTE Frequency Band	LTE 1/2/3/4/5/7/17/28/38/41
Additional Communication Function	BT4.2;WiFi 802.11a,b,g,n;NFC;GPS;

3.2. Internal Identification of EUT used during the test

EUT ID*	SN or IMEI	HW Version	SW Version	Date of receipt
N04	865150030742925/ 865150030742926	B1691_MAIN_PCB	V1.0.1	2019-07-23
N01	869006040013739/ 869006040014034	B1691_MAIN_PCB	V1.0.1	2019-07-23

*EUT ID: is used to identify the test sample in the lab internally.

3.3. Internal Identification of AE used during the test

AE ID*	Description	Model	SN
CA04	Adapter	TPA-23A050200UU01	NA
UA03	USB Cable	USB2.0 A/M TO TYPE C/M CABLE 1.5M black	NA
BA04	Battery	T6900	B19069011894
AE1	LAN Cable	NA	NA
AE2	RS232 Cable	NA	NA
AE3	VGA Cable	NA	NA
AE4	Keyboard	KB212-B	CN-0Y88XT-65890-12I-005Q-A00
AE5	Mouse	MS111-P	CN-011D3V-71581-19J-1A64
AE6	Desktop PC	OptiPlex 790 DT	X8RP1 A01 APCC
AE7	Notebook PC	DELL Latitude E6510	NA
AE8	SanDisk Ultra32GB	microSDHC UHS-I	NA

*AE ID: is used to identify the test sample in the lab internally.

*The AE were provided by the lab.

4. Reference Documents

4.1 Reference Documents for testing

The following documents listed in this section are referred for testing.

Reference	Title	Version
FCC Part 15, Subpart B	Radio frequency devices	2019/8/21
ANSI C63.4	Method of Measurement of Radio-Noise Emissions from Low-Voltage Electrical and Electronic Equipment in the Range of 9 kHz to 40 GHz	2014

5. Test Results

5.1 Summary of Test Results

Items	Test List	Clause in FCC rules	Verdict
1	Radiated Emission	15.109(a)	Pass
2	AC Conducted Emission	15.107(a)	Pass

5.2 Statements

The T6900, supporting GSMWCDMA/LTE.etc, manufactured by Shanghai Sunmi Technology Co.,Ltd. is a new product for testing. ECIT only performed test cases which identified with Pass/Fail/Inc result in section 5.1.

ECIT has verified that the compliance of the tested device specified in section 3 of this test report is successfully evaluated according to the procedure and test methods as defined in type certification requirement listed in section 4 of this test report.

Note: This project has two sets of configured sample N04 (No fingerprint) and N01 (With the fingerprint), among which the N04 sample is the main test, and the N01 sample tests the worst mode of the N04 sample.

6. Test Equipment Utilized

6.1 Radiated Emission Equipment list

Item	Instrument Name	Type	Serial Number	Manufacturer	Cal. Date	Cal. interval
1	Universal Radio Communication	CMU200	123126	R&S	2019-05-10	1 year
2	Universal Radio Communication	CMW500	104178	R&S	2019-05-10	1 year
3	Test Receiver	ESU40	100307	R&S	2019-05-10	1 year
4	Trilog Antenna	VULB9163	VULB9163-5 15	Schwarzbeck	2017-02-25	3 years
5	Double Ridged Guide	ETS-3117	00135885	ETS	2017-01-11	3 years
6	EMI Test Software	EMC32 V9.15	NA	R&S	NA	NA
7	GPS Simulator	GSS 4200	1182	SPIRENT	2018-12-17	1 year

6.1 AC Conducted Emission Equipment list

Item	Instrument Name	Type	Serial Number	Manufacturer	Cal. Date	Cal. interval
1	Universal Radio Communication	CMU200	123123	R&S	2019-05-10	1 year
2	Universal Radio Communication	CMW500	104178	R&S	2019-05-10	1 year
3	Test Receiver	ESCI	101235	R&S	2019-05-10	1 year
4	2-Line V-Network	ENV216	101380	R&S	2019-04-24	1 year
5	EMI Test Software	EMC32 V10.35.02	NA	R&S	NA	NA
6	GPS Simulator	GSS 4200	1182	SPIRENT	2018-12-17	1 year

7. System Configuration during Test

7.1 Test Mode

N04 Sample:

Test Item	Function Type
AC Conducted Emission	Mode 1: USB cable (Data Link with PC) <Figure 1> Mode 2: Adapter charging <Figure 2> Mode 3: GPS mode <Figure 2> Mode 4: GSM 850 receiver <Figure 2>
Radiated Emission	Mode 1: USB cable (Data Link with PC) <Figure 1> Mode 2: Adapter charging <Figure 2> Mode 3: GPS mode <Figure 2> Mode 4: GSM 850 receiver <Figure 2>
Remark: 1. All test modes are performed, only the worst cases test data are recorded in this report. 2. After laboratory verification, GSM850 receiver is the worst mode of receiving part. 3. Data Link with PC means data application transferred mode between EUT and PC. 4. EUT and GPS simulator (GSS4200) connection is established. 5. The worst case for conducted emission is mode 2. The worst case of radiated emission for 30MHz-1GHz is mode 2 and for 1GHz -18GHz is mode 2.	

N01 Sample:

Test Item	Function Type
AC Conducted Emission	Mode 2: Adapter charging <Figure 2>
Radiated Emission	Mode 2: Adapter charging <Figure 2>
Remark: 1. All test modes are performed, only the worst cases test data are recorded in this report. 2. After laboratory verification, GSM850 receiver is the worst mode of receiving part. 3. Data Link with PC means data application transferred mode between EUT and PC. 4. EUT and GPS simulator (GSS4200) connection is established. 5. The worst case for conducted emission is mode 2. The worst case of radiated emission for 30MHz-1GHz is mode 2 and for 1GHz -18GHz is mode 2.	

7.2 Connection Diagram of Test System

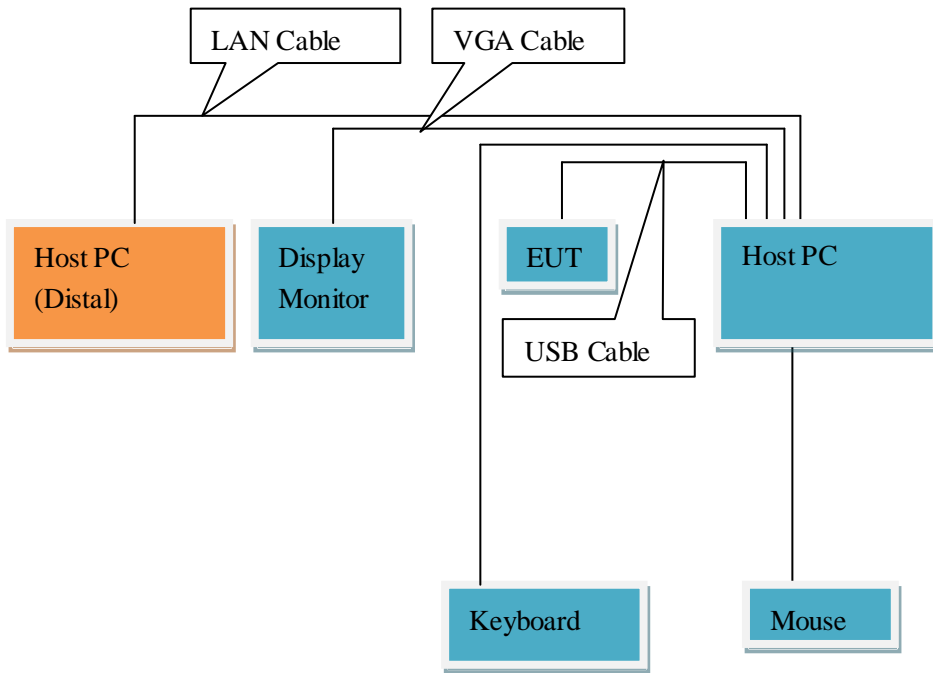

<Figure 1> Mode 1

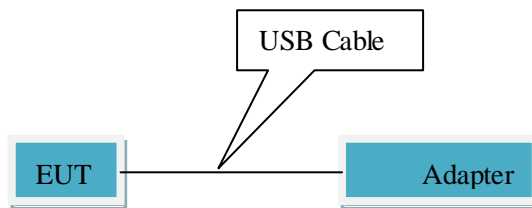

<Figure 2> Mode 2~4

8. Measurement Results

Only the worst test result was shown in this report.

8.1 Radiated Emission 30MHz-18GHz

Method of Measurement

For 30MHz -1000MHz, the EUT was placed on the top of a rotating 0.8m table above the ground at a semi-anechoic chamber. The distance between the EUT and the received antenna was 3 meters. The table was rotated 360 degree and the received antenna mounted on a variable-height antenna tower was varied from 1m to 4m to find the maximum value of the field strength. Both horizontal and vertical polarizations of the antenna were set during the measurement. Tested in accordance with the procedures of ANSI C63.4-2014, section 8.3.

For 1000MHz-18000MHz, The maximal emission value was acquired by adjusting the antenna height, The table was rotated 360 degree to determine the maximum value of the field strength. Both horizontal and vertical polarizations of the antenna were set during the measurement.

Limits for Radiated Emission at a measuring distance of 3m

Frequency Range (MHz)	Quasi-Peak (dBuV/m)
30-88	40
88-216	43.5
216-960	46
Above 960	54

Frequency Range (MHz)	Peak (dBuV/m)	Average (dBuV/m)
Above 1000	74	54

Test conditions

Frequency Range (MHz)	RBW/VBW	Sweep Time (s)
30-1000	120kHz/300kHz	Auto
1000-18000	1MHz/3MHz	Auto

Uncertainty Measurement

The measurement uncertainty (30MHz-1000MHz) is 4.98 dB (k=2).

The measurement uncertainty (1000MHz-18000MHz) is 5.06 dB (k=2).

Test Results

Sweep the whole frequency band through the range from 30MHz to the 5th harmonic of the carrier, the Emissions in the frequency band 18GHz-40GHz is more than 20dB below the limit are not report.

N04 Sample_ Mode 2: Adapter charging <Figure 2>

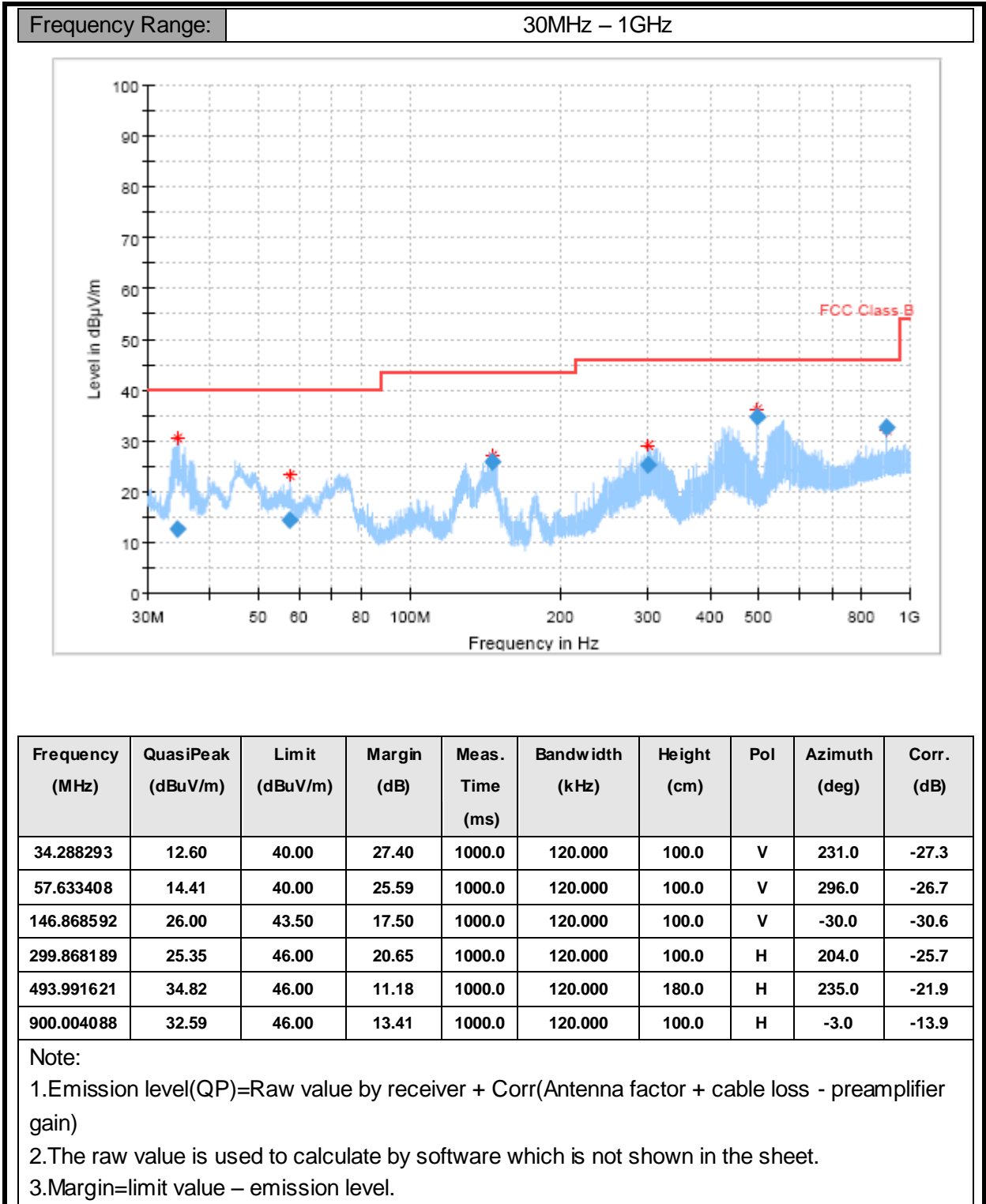

N04 Sample_ Mode 2: Adapter charging <Figure 2>

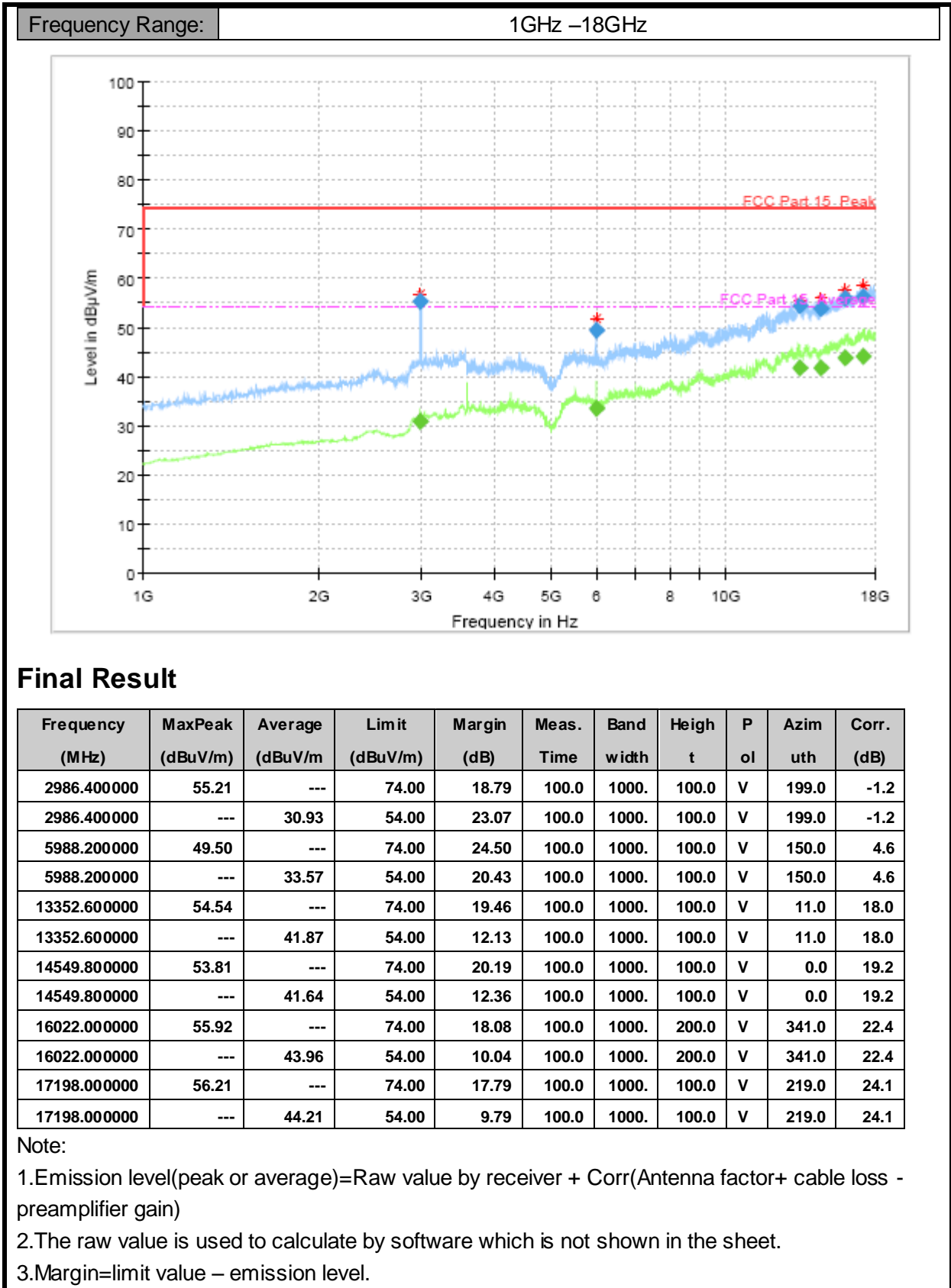

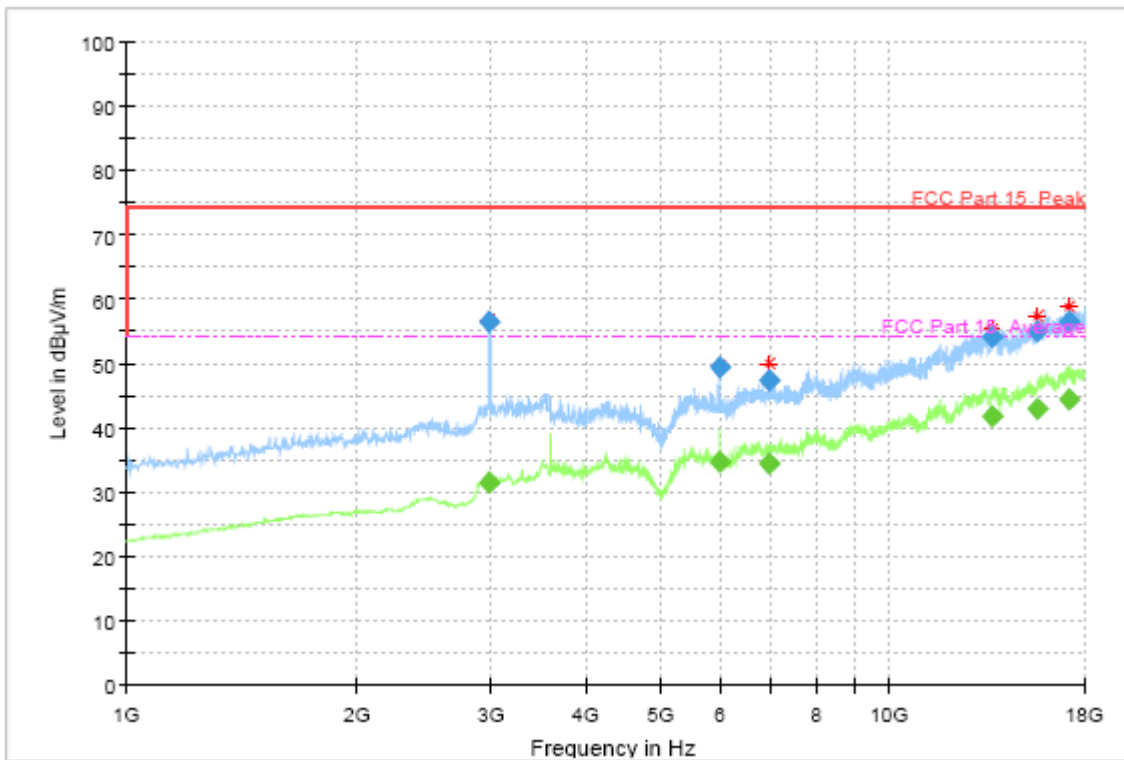

Final Result

Frequency (MHz)	MaxPeak (dBuV/m)	Average (dBuV/m)	Limit (dBuV/m)	Margin (dB)	Meas. Time	Bandwidth	Height	Po l	Azimuth	Corr. (dB)
2991.600000	56.56	---	74.00	17.44	100.0	1000.00	200.0	H	190.0	-1.3
2991.600000	---	31.43	54.00	22.57	100.0	1000.00	200.0	H	190.0	-1.3
5999.000000	49.48	---	74.00	24.52	100.0	1000.00	200.0	H	138.0	4.6
5999.000000	---	34.82	54.00	19.18	100.0	1000.00	200.0	H	138.0	4.6
6969.800000	47.49	---	74.00	26.51	100.0	1000.00	100.0	H	62.0	7.1
6969.800000	---	34.30	54.00	19.70	100.0	1000.00	100.0	H	62.0	7.1
13589.800000	---	41.71	54.00	12.29	100.0	1000.00	200.0	H	96.0	18.3
13589.800000	54.08	---	74.00	19.92	100.0	1000.00	200.0	H	96.0	18.3
15599.000000	54.92	---	74.00	19.08	100.0	1000.00	100.0	H	176.0	21.3
15599.000000	---	42.82	54.00	11.18	100.0	1000.00	100.0	H	176.0	21.3
17160.600000	---	44.46	54.00	9.54	100.0	1000.00	200.0	H	274.0	24.1
17160.600000	56.44	---	74.00	17.56	100.0	1000.00	200.0	H	274.0	24.1

Note:

1. Emission level(peak or average)=Raw value by receiver + Corr(Antenna factor+ cable loss - preamplifier gain)
2. The raw value is used to calculate by software which is not shown in the sheet.
3. Margin=limit value – emission level.

N01 Sample_ Mode 2: Adapter charging <Figure 2>

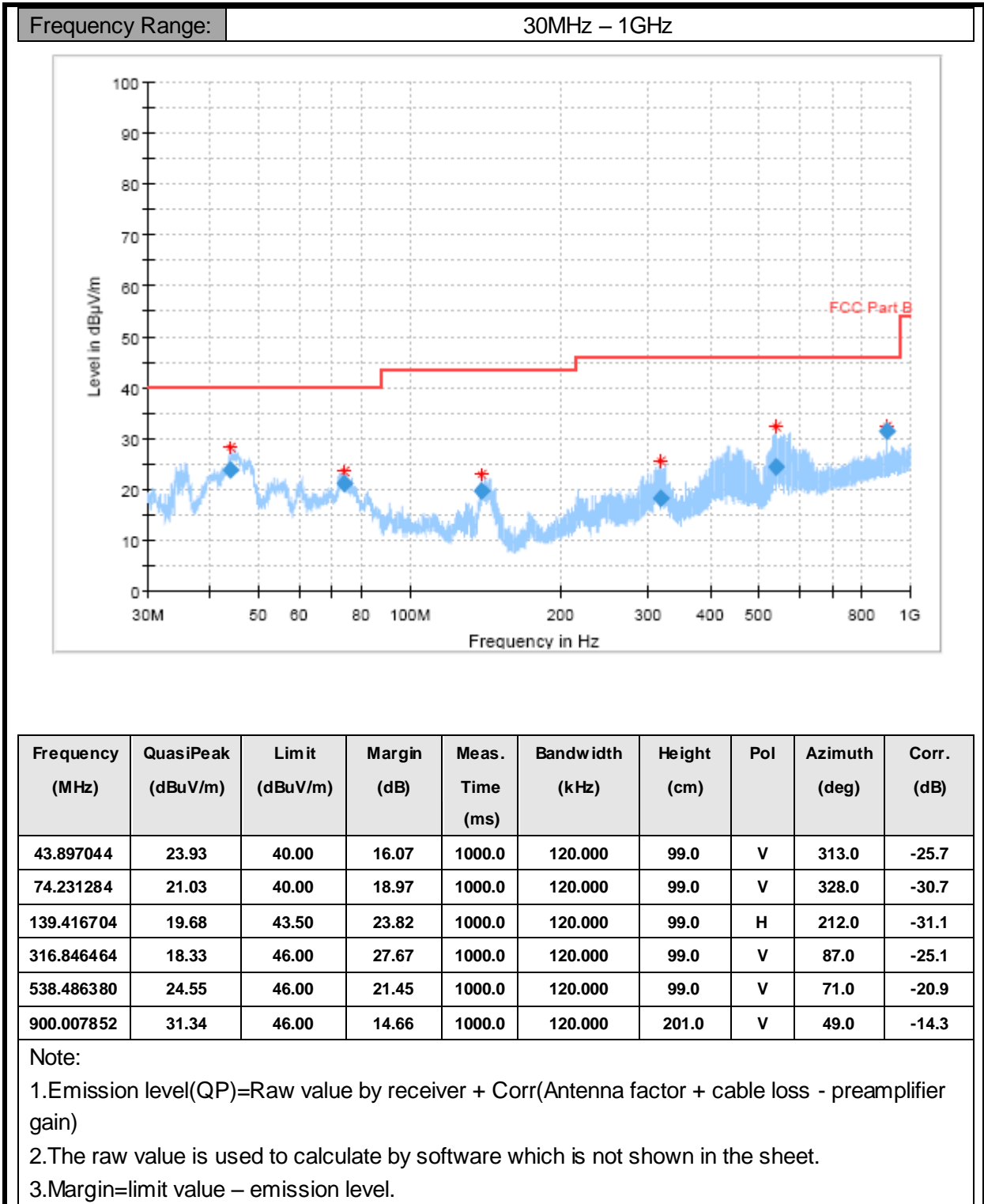

N01 Sample_ Mode 2: Adapter charging <Figure 2>

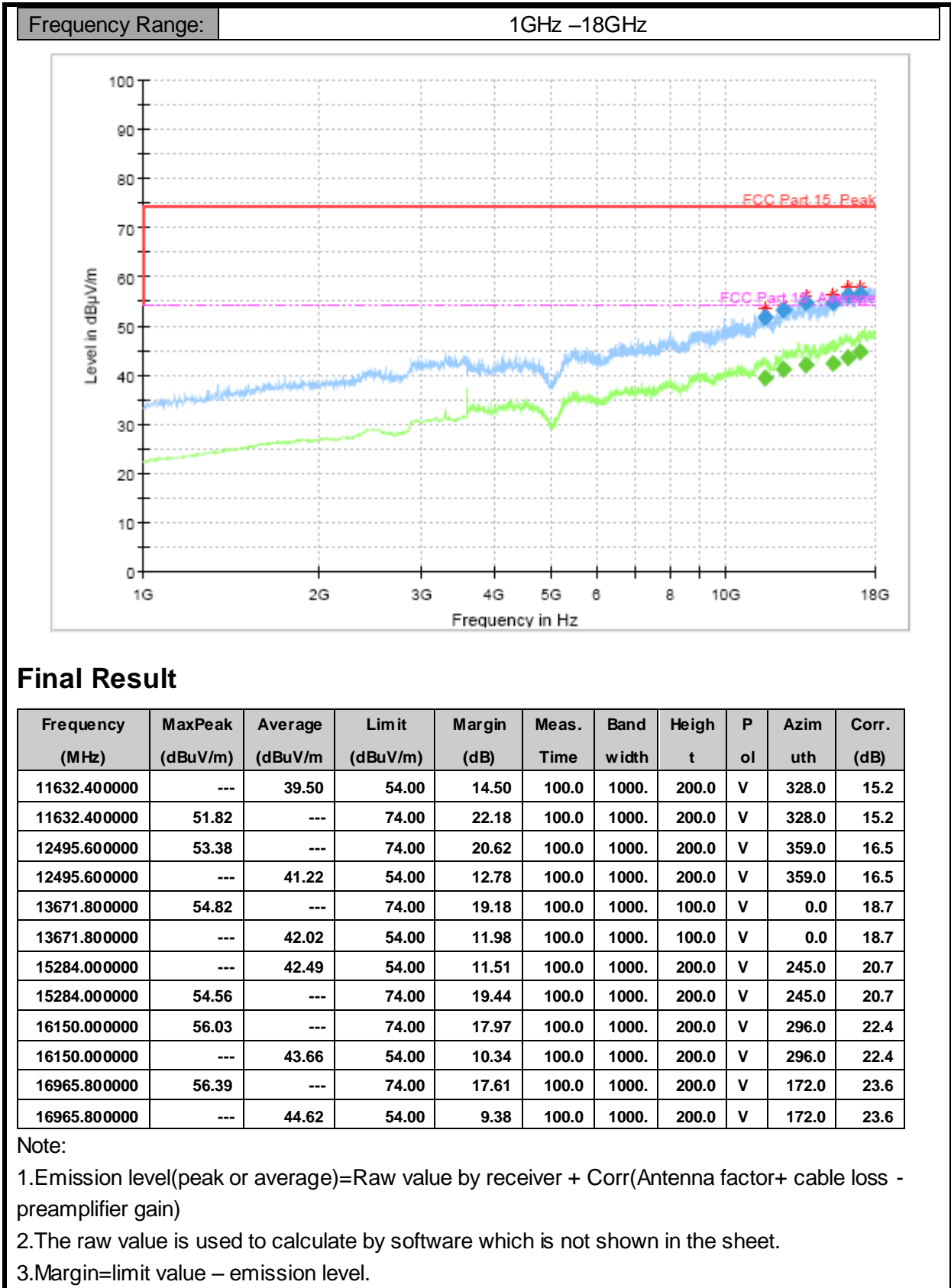

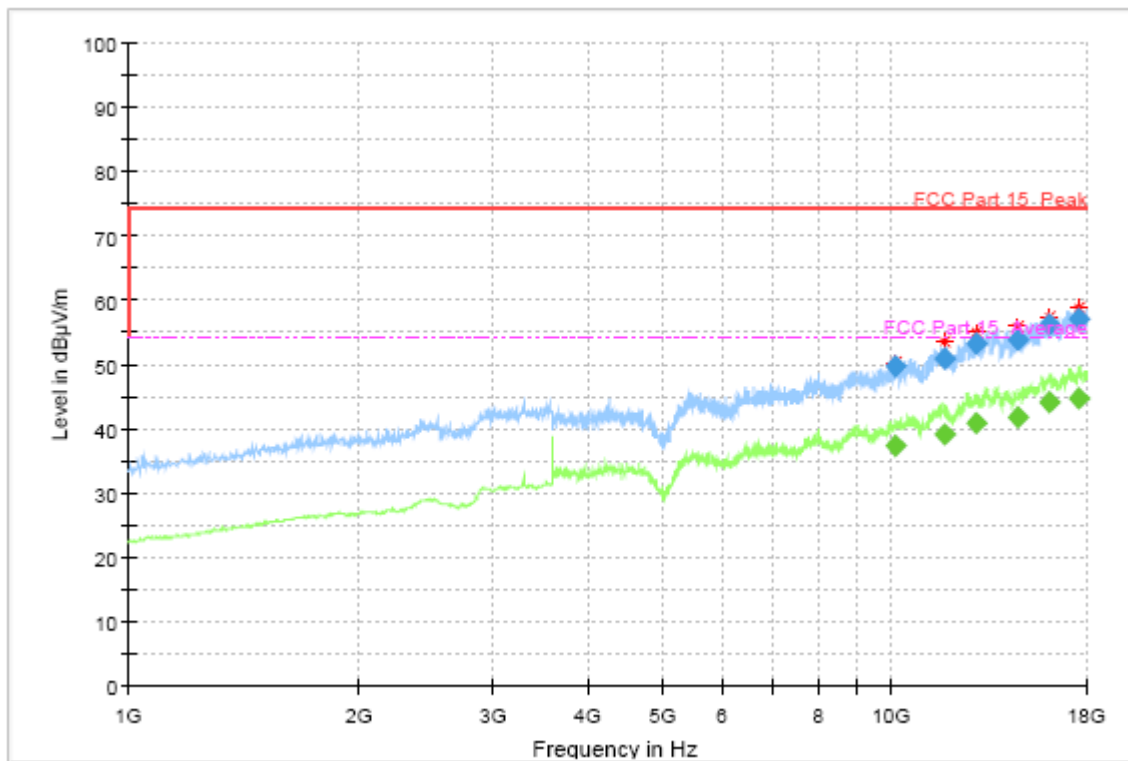

Final Result

Frequency (MHz)	MaxPeak (dBuV/m)	Average (dBuV/m)	Limit (dBuV/m)	Margin (dB)	Meas. Time	Bandwidth	Height	Po l	Azimu th	Corr. (dB)
10121.400000	49.63	---	74.00	24.37	100.0	1000.00	100.0	H	10121.	11.7
10121.400000	---	37.43	54.00	16.57	100.0	1000.00	100.0	H	10121.	11.7
11736.400000	51.01	---	74.00	22.99	100.0	1000.00	200.0	H	11736.	15.1
11736.400000	---	39.16	54.00	14.84	100.0	1000.00	200.0	H	11736.	15.1
12883.200000	53.32	---	74.00	20.68	100.0	1000.00	100.0	H	12883.	17.5
12883.200000	---	40.99	54.00	13.01	100.0	1000.00	100.0	H	12883.	17.5
14633.800000	53.89	---	74.00	20.11	100.0	1000.00	200.0	H	14633.	19.6
14633.800000	---	41.70	54.00	12.30	100.0	1000.00	200.0	H	14633.	19.6
16037.200000	56.14	---	74.00	17.86	100.0	1000.00	200.0	H	16037.	22.5
16037.200000	---	44.11	54.00	9.89	100.0	1000.00	200.0	H	16037.	22.5
17534.800000	57.02	---	74.00	16.98	100.0	1000.00	100.0	H	17534.	24.6
17534.800000	---	44.72	54.00	9.28	100.0	1000.00	100.0	H	17534.	24.6

Note:

1. Emission level(peak or average)=Raw value by receiver + Corr(Antenna factor+ cable loss - preamplifier gain)
2. The raw value is used to calculate by software which is not shown in the sheet.
3. Margin=limit value – emission level.

8.2 AC Conducted Emission

Method of Measurement

For equipment that is designed to be connected to the public utility (AC) power line, the radio frequency voltage that is conducted back onto the AC power line on any frequency or frequencies with the band 150 kHz to 30MHz shall not exceed the limits. Both lines of the power mains connected to the EUT were checked for maximum conducted interference. Tested in accordance with the procedures of ANSI C63.4-2014, section 7.3

Limit of Conducted Emission

Frequency Range (MHz)	Conducted Limit (dBuV)	
	Quasi-peak	Average
0.15-0.5	66 to 56*	56 to 46*
0.5-5	56	46
5-30	60	50

*Decreases with the logarithm of the frequency

Test Condition in Charging Mode

Voltage (V)	Frequency (Hz)	RBW	Sweep Time (s)
120	60	9 kHz	Auto

Uncertainty Measurement

The measurement uncertainty is 3.66dB (k=2).

Test Results

N04 Sample_ Mode 2: Adapter charging <Figure 2>

Frequency Range: 150kHz – 30MHz

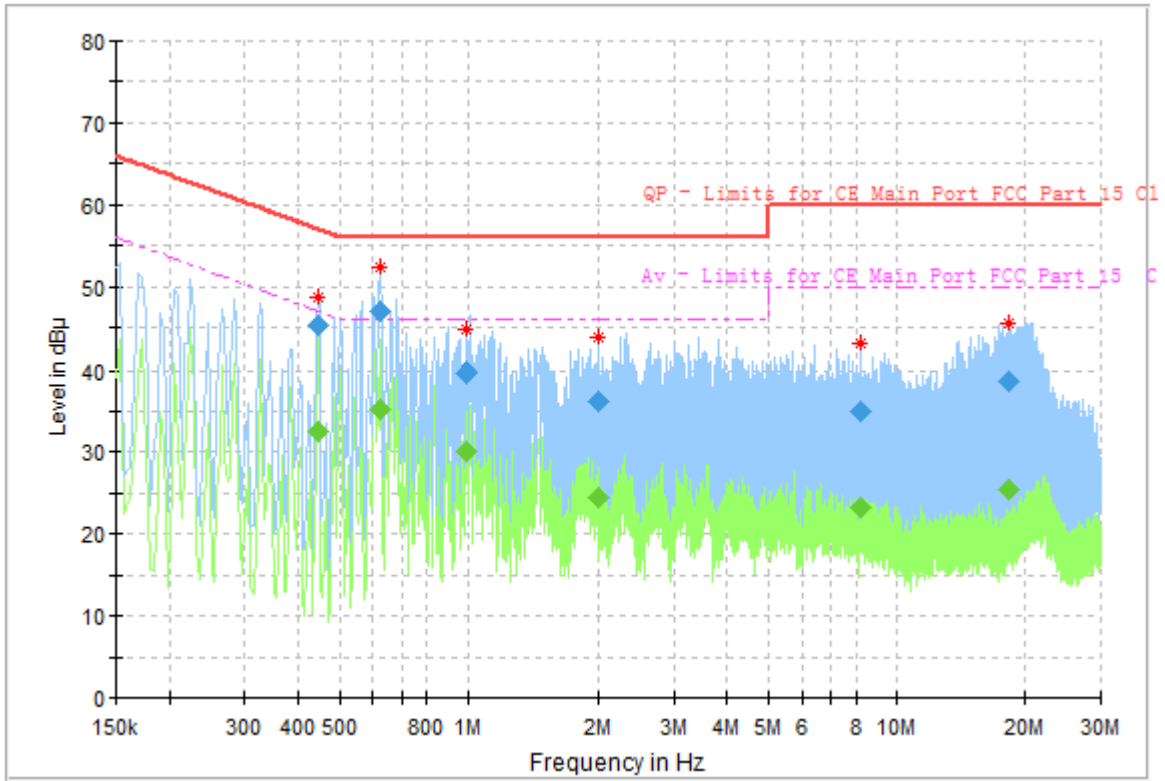

Frequency (MHz)	QuasiPeak (dBμ V)	Average (dBμ V)	Limit (dBμ V)	Margin (dB)	Meas. Time	Bandwidth (kHz)	Line	Filter	Corr. (dB)
0.444769	---	32.44	46.97	14.53	15000.	9.000	L1	ON	9.8
0.444769	45.20	---	56.97	11.78	15000.	9.000	L1	ON	9.8
0.620138	---	35.13	46.00	10.87	15000.	9.000	L1	ON	9.8
0.620138	46.96	---	56.00	9.04	15000.	9.000	L1	ON	9.8
0.993263	---	30.11	46.00	15.89	15000.	9.000	L1	ON	9.9
0.993263	39.67	---	56.00	16.33	15000.	9.000	L1	ON	9.9
1.993238	---	24.35	46.00	21.65	15000.	9.000	N	ON	10.0
1.993238	36.13	---	56.00	19.87	15000.	9.000	N	ON	10.0
8.179650	---	23.32	50.00	26.68	15000.	9.000	N	ON	10.7
8.179650	34.87	---	60.00	25.13	15000.	9.000	N	ON	10.7
18.164475	---	25.38	50.00	24.62	15000.	9.000	N	ON	13.6
18.164475	38.69	---	60.00	21.31	15000.	9.000	N	ON	13.6

Note:

1. Emission level (quasi-peak or Average peak) = Raw value by receiver + Corr (Insertion loss + cable loss)
2. The raw value is used to calculate by software which is not shown in the sheet.
3. Margin = limit value – emission level.
4. L1 and N line is all have been tested, the result of them is synthesized in the above data diagram.

N01 Sample_ Mode 2: Adapter charging <Figure 2>

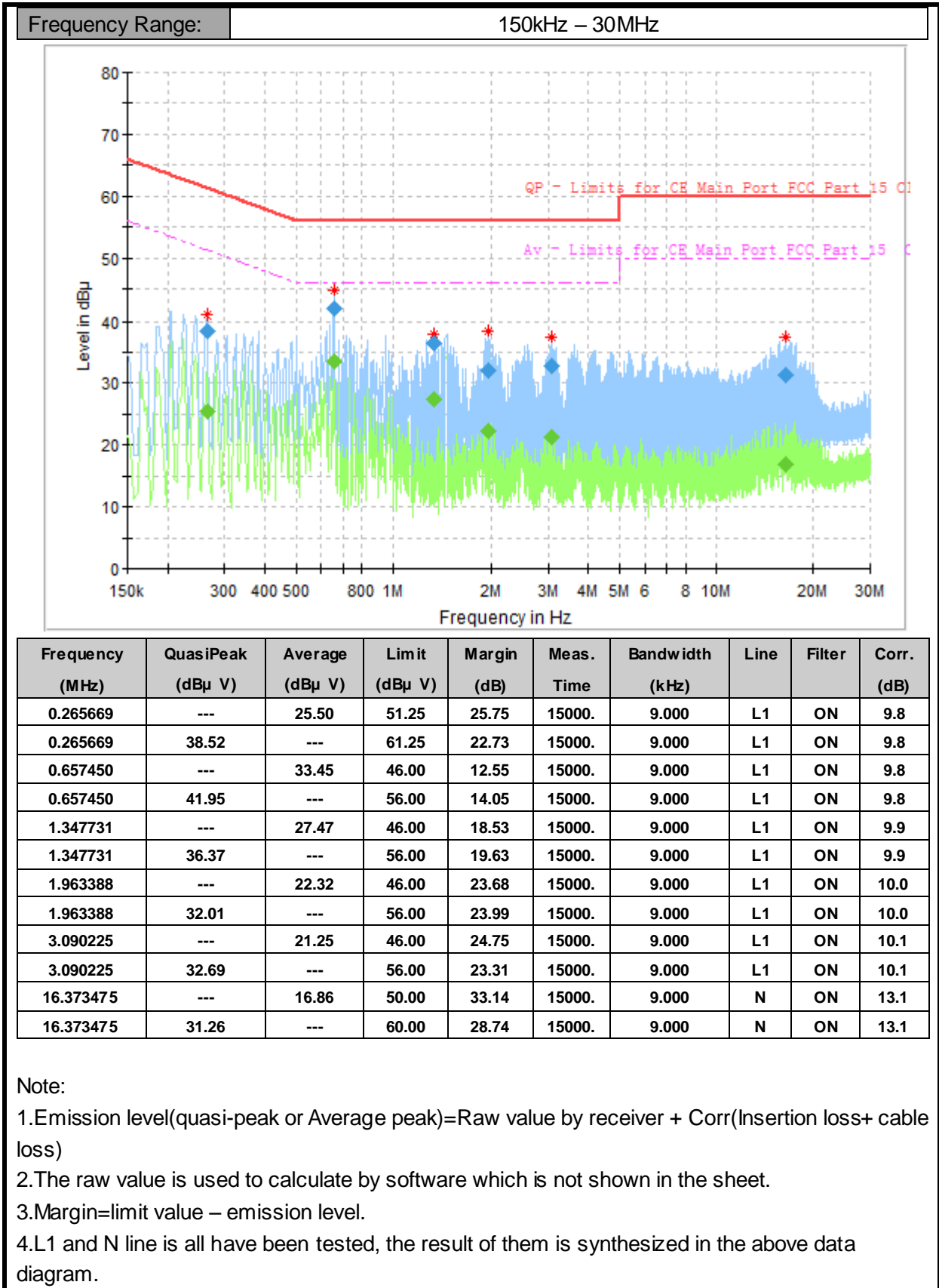

*****END OF REPORT*****