

**Industrial Internet Innovation Center (Shanghai) Co.,Ltd.****FCC/IC 5.8G WIFI TEST REPORT**

<b>PRODUCT</b>	Wireless data POS System
<b>BRAND</b>	SUNMI
<b>MODEL</b>	T5820
<b>FCC ID</b>	2AH25T5820C
<b>IC</b>	22621-T5820C
<b>APPLICANT</b>	Shanghai Sunmi Technology Co.,Ltd.
<b>ISSUE DATE</b>	January 31, 2023
<b>STANDARD(S)</b>	FCC Part15, RSS-247 Issue 2, RSS-Gen Issue 5

Prepared by: *Tao Lingyan*Reviewed by: *Yang Fan*Approved by: *Zhang Min***CAUTION:**

*This report shall not be reproduced except in full without the written permission of the test laboratory and shall not be quoted out of context.*

## CONTENTS

<b>1. SUMMARY OF TEST REPORT .....</b>	<b>3</b>
1.1 TEST STANDARD(S) .....	3
1.2 REFERENCE DOCUMENTS.....	3
1.3 SUMMARY OF TEST RESULTS.....	3
1.4 DATA PROVIDED BY APPLICANT.....	4
<b>2. GENERAL INFORMATION OF THE LABORATORY .....</b>	<b>5</b>
2.1 TESTING LABORATORY .....	5
2.2 MENTS.....	5
2.3 PROJECT INFORMATION.....	5
<b>3. GENERAL INFORMATION OF THE CUSTOMER.....</b>	<b>6</b>
3.1 APPLICANT .....	6
3.2 MANUFACTURER .....	6
<b>4. GENERAL INFORMATION OF THE PRODUCT.....</b>	<b>7</b>
4.1 PRODUCT DESCRIPTION FOR EQUIPMENT UNDER TEST (EUT).....	7
4.2 INTERNAL IDENTIFICATION OF AE USED DURING THE TEST.....	7
4.3 ADDITIONAL INFORMATION .....	7
<b>5. TEST CONFIGURATION INFORMATION .....</b>	<b>9</b>
5.1 LABORATORY ENVIRONMENTAL CONDITIONS.....	9
5.2 TEST EQUIPMENTS UTILIZED.....	9
5.3 MEASUREMENT UNCERTAINTY .....	11
<b>6. MEASUREMENT RESULTS .....</b>	<b>12</b>
6.1 OCCUPIED CHANNEL BANDWIDTH .....	12
6.2 MIN EMISSION BANDWIDTH.....	19
6.3 MAXIMUM CONDUCTED OUTPUT POWER.....	26
6.4 MAXIMUM POWER SPECTRAL DENSITY .....	33
6.5 FREQUENCY STABILITY .....	41
6.6 TRANSMITTER SPURIOUS EMISSION.....	42
6.7 BAND EDGES COMPLIANCE.....	46
6.8 AC POWERLINE CONDUCTED EMISSION .....	48
<b>ANNEX A: REVISED HISTORY.....</b>	<b>51</b>
<b>ANNEX B: ACCREDITATION CERTIFICATE.....</b>	<b>52</b>

## 1. Summary of Test Report

### 1.1 Test Standard(s)

No.	Test Standard(s)	Title	Version
1	FCC Part15	Title 47 of the Code of Federal Regulations; Chapter I Part 15 - Radio frequency devices	2020
2	RSS-247 Issue 2	Digital Transmission Systems (DTSs), Frequency Hopping Systems (FHSs) and Licence-Exempt Local Area Network (LE-LAN) Devices	2017
3	RSS-Gen Issue 5	General Requirements for Compliance of Radio Apparatus	2021

### 1.2 Reference Documents

No.	Reference	Title	Version
1	ANSI 63.10	Methods of Measurement of Radio-Noise Emissions from Low-Voltage Electrical and Electronic Equipment in the Range of 9 kHz to 40 GHz	2013
2	KDB 789033	Information Infrastructure (U-NII) Devices - Part 15, Subpart E	2017
3	KDB 905462	COMPLIANCE MEASUREMENT PROCEDURES FOR UNLICENSED-NATIONAL INFORMATION INFRASTRUCTURE DEVICES OPERATING IN THE 5250-5350 MHz AND 5470-5725 MHz BANDS INCORPORATING DYNAMIC FREQUENCY SELECTION	2016

### 1.3 Summary of Test Results

Measurement Items	Sub-clause of Part15C	Sub-clause of IC	Verdict
Maximum Output Power	15.407(a)	RSS-247 6.2	Pass
Power Spectral Density	15.407(a)	RSS-247 6.2	Pass
6dB Occupied Bandwidth	15.407(e)	RSS-247 6.2	Pass
99% Occupied Bandwidth	15.407(e)	RSS-GEN 6.7	Pass
Band edge compliance	15.407(b)	RSS-247 6.2	Pass
Transmitter Spurious Emission-Conducted	15.407	RSS-247 6.2	Pass
Transmitter Spurious Emission - Radiated	15.407,15.205,15.209	RSS-247 6.2 RSS-Gen 8.9,8.10	Pass
AC Powerline Conducted Emission	15.207	RSS-Gen 8.8	Pass

**Note:**

The T5820, manufactured by Shanghai Sunmi Technology Co.,Ltd. is a new product for testing.

The product's Band 41 uses only 2535-2655 MHZ.

Industrial Internet Innovation Center (Shanghai) Co., Ltd. only performed test cases which identified with Pass/Fail/Inc result in section 1.

Industrial Internet Innovation Center (Shanghai) Co., Ltd. has verified that the compliance of the tested device specified in section 1.3 of this test report is successfully evaluated according to the procedure and

test methods as defined in type certification requirement listed in section 4 of this test report.

- a. All the test data for each data were verified, but only the worst case was reported.
- b. The DC and low frequency voltages' measurement uncertainty is  $\pm 2\%$ .
- c. Activate simultaneous transmission in all possible configurations during the testing.

#### 1.4 Data Provided by Applicant

No.	Item(s)	Data
1	Antenna gain of EUT	3.31 dBi

Note: The data of 1.4 is provided by the customer may affect the validity of the test results in this report, and the impact and consequences of this shall be undertaken by the customer.

## 2. General Information of The Laboratory

### 2.1 Testing Laboratory

Lab Name	Industrial Internet Innovation Center (Shanghai) Co.,Ltd.
Address	Building 4, No. 766, Jingang Road, Pudong, Shanghai, China
Telephone	021-68866880
FCC Registration No.	958356
FCC Designation No.	CN1177
IC Designation No.	10766A

### 2.2 ments

Temperature	15°C~35°C
Relative Humidity	25%RH~75%RH
Atmospheric Pressure	101kPa

### 2.3 Project Information

Project Manager	Gao Hongning
Test Date	October 20, 2022 to December 15, 2022

### 3. General Information of The Customer

#### 3.1 Applicant

Company	Shanghai Sunmi Technology Co.,Ltd.
Address	Room 505, No.388, Song Hu Road, Yang Pu District, Shanghai, China
Telephone	13510126210

#### 3.2 Manufacturer

Company	Shanghai Sunmi Technology Co.,Ltd.
Address	Room 505, No.388, Song Hu Road, Yang Pu District, Shanghai, China

## 4. General Information of The Product

### 4.1 Product Description for Equipment under Test (EUT)

Product	Wireless data POS System
Model	T5820
Date of Receipt	S01aa/ S06aa:October 20,2022 S11aa:December 08, 2022
EUT ID*	S01aa/S11aa/S06aa
SN/IMEI	S01aa:860450060018328 860450060018336 S11aa:N/A S06aa: 860450060018740 860450060018757
Supported Radio Technology and Bands	GSM850/GSM900/DCS1800/PCS1900 WCDMA Band I/II/IV/V/VIII LTE Band 1/2/3/4/5/7/12/17/28/38/41 WLAN 802.11 b/g/n WLAN 802.11 a/n/ac BT5.1 BR/EDR, BLE NFC GPS/Glonass/BDS
HVIN	T5820C
Hardware Version	V01
Software Version	XQT530_V004_20220923
FCC ID	2AH25T5820C
IC	22621-T5820C
NOTE: EUT ID is the internal identification code of the laboratory.	

### 4.2 Internal Identification of AE used during the test

AE ID*	Description	Model	SN/Remark
AE1	RF Cable	N/A	N/A

### 4.3 Additional Information

WLAN Frequency	UNII 3: 5725MHz-5850MHz
Occupied Channel Bandwidth	20 MHz for Wi-Fi (802.11 a/n/ac) 40 MHz for Wi-Fi (802.11 ac) 80 MHz for Wi-Fi(802.11 ac)

WLAN type of modulation	OFDM
-------------------------	------



## 5. Test Configuration Information

### 5.1 Laboratory Environmental Conditions

#### 5.1.1 Permanent Facilities

Relative Humidity	Min. = 45 %, Max. = 55 %		
Atmospheric Pressure	101kPa		
Temperature	Normal	Minimum	Maximum
	25°C	0°C	45°C
Working Voltage of EUT	Normal	Minimum	Maximum
	7.2V	6.8V	8.4V

### 5.2 Test Equipments Utilized

#### 5.2.1 Conducted Test System

No.	Name	Model	S/N	Manufacturer	Cal. Date	Cal. Interval
1	Programmable Power Supply	Keithley 2303	4039070	Starpoint	July 12, 2022	1 Year
2	Vector Signal Generator	SMBV100 A	257904	R&S	February 21, 2022	1 Year
3	Temperature box	B-TF-107C	BTF107C-201804107	Boyi	June 30, 2022	1 Year
4	Spectrum Analyzer	FSQ40	200063	R&S	October 19, 2022	1 year
5	USB Wideband Power Sensor	U2021XA	MY56410009	Keysight	February 21, 2022	1 Year
6	Simultaneous Sampling DQA	U2531A	TW56183514	Agilent	March 02, 2022	1 Year
7	Vector Signal Generator	SMU200A	104684	R&S	August 22, 2022	1 Year
8	Wireless communication comprehensive tester	CMW270	100919	R&S	August 22, 2022	1 Year
9	Eagle Test Software	Eagle V3.3	N/A	ECIT	N/A	N/A
10	Talent Microwave Band Rejection Filter	Filter	191016001	N/A	N/A	N/A

**5.2.2 Radiated Emission Test System**

No.	Name	Model	S/N	Manufacturer	Cal. Date	Cal. Interval
1	Universal Radio Communication Tester	CMU200	123123	R&S	October 17,2022	1Year
2	Universal Radio Communication Tester	CMW500	104178	R&S	October 17,2022	1Year
3	EMI Test Receiver	ESU40	100307	R&S	February 23, 2022	1 Year
4	TRILOG Broadband Antenna	VULB9163	VULB9163-515	Schwarzbeck	March 11, 2022	1 Year
5	Double- ridged Waveguide Antenna	ETS-3117	00135890	ETS	March 9, 2022	2 Years
6	2-Line V-Network	ENV216	101380	R&S	February 21, 2022	1 Year
7	EMI Test Software	EMC32 V9.15.00	N/A	R&S	N/A	N/A

**5.2.3 Radiated Emission Test System**

**Shielding Room1** (6.0 meters×3.0 meters×2.7 meters) did not exceed following limits along the conducted RF performance testing:

Temperature	Min. = 15 °C, Max. = 35 °C
Relative humidity	Min. = 20 %, Max. = 75 %
Shielding effectiveness	> 100 dB
Ground system resistance	< 0.5 Ω
Temperature	Min. = 15 °C, Max. = 35 °C

**Control room** did not exceed following limits along the EMC testing:

Temperature	Min. = 15 °C, Max. = 35 °C
Relative humidity	Min. =30 %, Max. = 60 %
Shielding effectiveness	> 100 dB
Electrical insulation	> 10 kΩ
Ground system resistance	< 0.5 Ω

**Fully-anechoic chamber1** (9.8 meters×6.7 meters×6.7 meters) did not exceed following limits along the EMC testing:

Temperature	Min. = 15 °C, Max. = 35 °C
Relative humidity	Min. = 25 %, Max. = 75 %
Shielding effectiveness	> 100 dB

Electrical insulation	> 10 kΩ
Ground system resistance	< 0.5 Ω
VSWR	Between 0 and 6 dB, from 1GHz to 18GHz
Site Attenuation Deviation	Between -4 and 4 dB,30MHz to 1GHz

### 5.3 Measurement Uncertainty

Item(s)	Range	Confidence Level	Calculated Uncertainty
Peak Output Power-Conducted	5100MHz-5875MHz	95%	1.024dB
Peak Power Spectral Density	5100MHz-5875MHz	95%	1.024dB/MHz
Conducted Emission	9KHz-30MHz	95%	0.89dB
Conducted Emission	30MHz-2GHz	95%	0.90dB
Conducted Emission	2GHz-3.6GHz	95%	0.88dB
Conducted Emission	3.6GHz-8GHz	95%	0.96dB
Conducted Emission	8GHz-20GHz	95%	0.94dB
Conducted Emission	20GHz-22GHz	95%	0.88dB
Conducted Emission	22GHz-26GHz	95%	0.86dB
Transmitter Spurious Emission-Radiated	9KHz-30MHz	95%	5.66dB
Transmitter Spurious Emission-Radiated	30MHz-1000MHz	95%	4.98dB
Transmitter Spurious Emission-Radiated	1000MHz -18000MHz	95%	5.06dB
Transmitter Spurious Emission-Radiated	18000MHz -40000MHz	95%	5.20dB
AC Power line Conducted Emission	0.15MHz-30MHz	95%	3.66 dB

## 6. Measurement Results

### 6.1 Occupied channel bandwidth

#### 6.1.1 Measurement Limit and Method

Standard	Limit(KHz)
RSS-Gen 6.7	N/A

The measurement method is made according to KDB 789033 D

1. Set center frequency to the nominal EUT channel center frequency.
2. Set span = 1.5 times to 5.0 times the OBW.
3. Set RBW = 1 % to 5 % of the OBW
4. Set VBW  $\geq 3 \cdot$  RBW
5. Video averaging is not permitted. Where practical, a sample detection and single sweep mode shall be used. Otherwise, peak detection and max hold mode (until the trace stabilizes) shall be used.
6. Use the 99 % power bandwidth function of the instrument (if available).
7. If the instrument does not have a 99 % power bandwidth function, the trace data points are recovered and directly summed in power units. The recovered amplitude data points, beginning at the lowest frequency, are placed in a running sum until 0.5 % of the total is reached; that frequency is recorded as the lower frequency. The process is repeated until 99.5 % of the total is reached; that frequency is recorded as the upper frequency. The 99% occupied bandwidth is the difference between these two frequencies.

#### 6.1.2 Test Setup

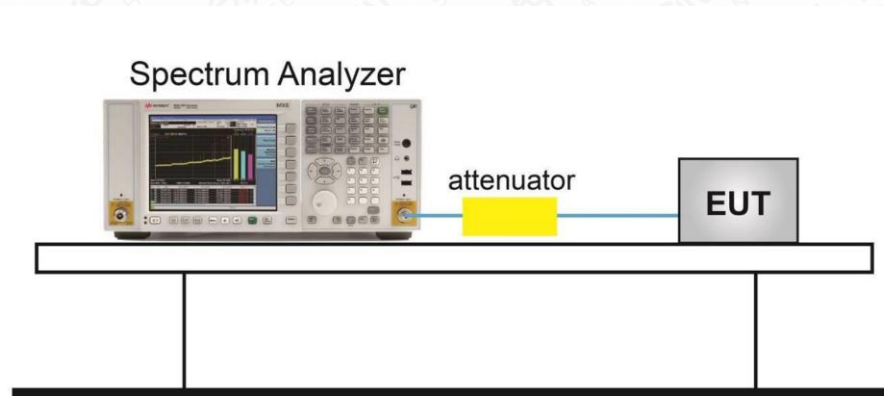

## 6.1.3 Test Result

TestMode	Antenna	Frequency[MHz]	OCB [MHz]	FL[MHz]	FH[MHz]
11A	Ant1	5745	17.88	5736.0400	5753.9200
11A	Ant1	5785	17.96	5776.0000	5793.9600
11A	Ant1	5825	17.88	5816.0400	5833.9200
11N20SISO	Ant1	5745	18.68	5735.6000	5754.2800
11N20SISO	Ant1	5785	18.88	5775.4800	5794.3600
11N20SISO	Ant1	5825	18.76	5815.5600	5834.3200
11N40SISO	Ant1	5755	37.52	5736.2800	5773.8000
11N40SISO	Ant1	5795	37.44	5776.2800	5813.7200
11AC20SISO	Ant1	5745	18.68	5735.6400	5754.3200
11AC20SISO	Ant1	5785	18.6	5775.6800	5794.2800
11AC20SISO	Ant1	5825	18.6	5815.6800	5834.2800
11AC40SISO	Ant1	5755	37.2	5736.4400	5773.6400
11AC40SISO	Ant1	5795	37.2	5776.3600	5813.5600
11AC80SISO	Ant1	5775	76.48	5736.7600	5813.2400

6.1.4 Test Graphs

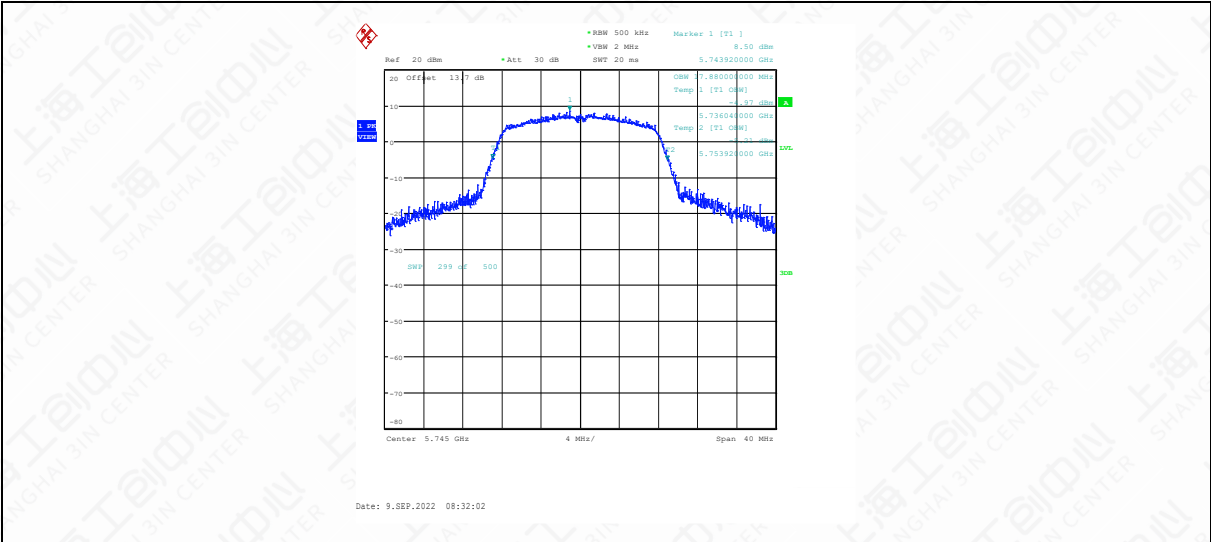

11A-Ant1-5745

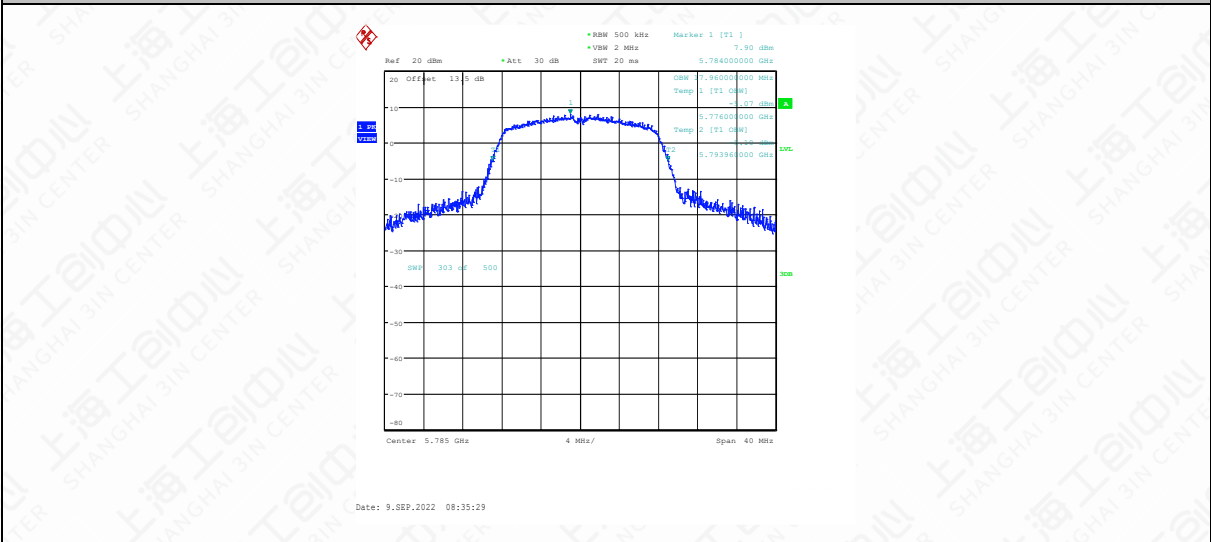

11A-Ant1-5785

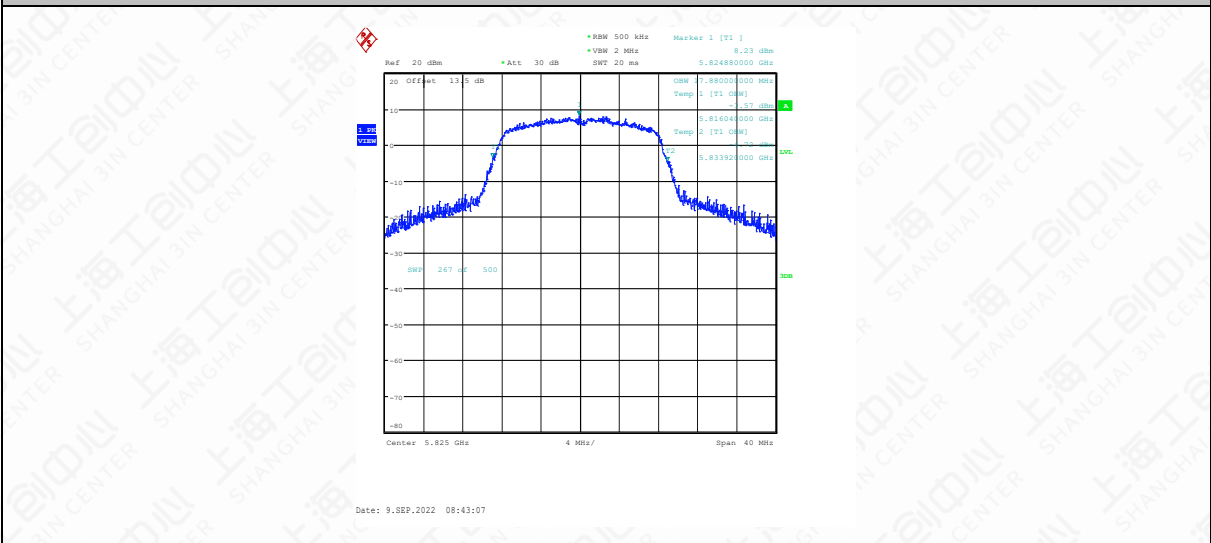

11A-Ant1-5825

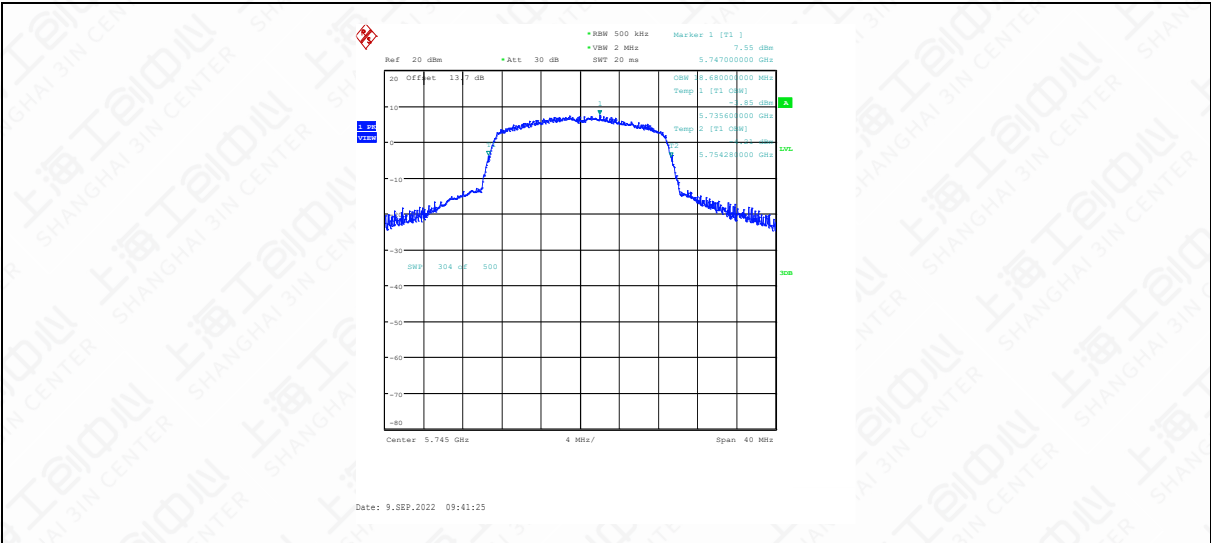

11N20SISO-Ant1-5745

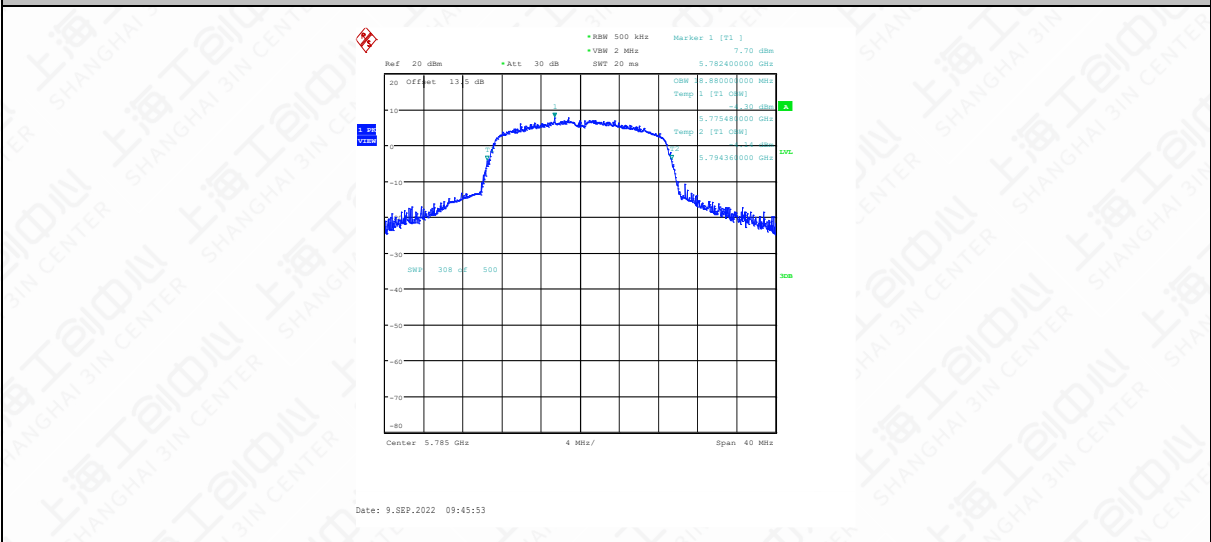

11N20SISO-Ant1-5785

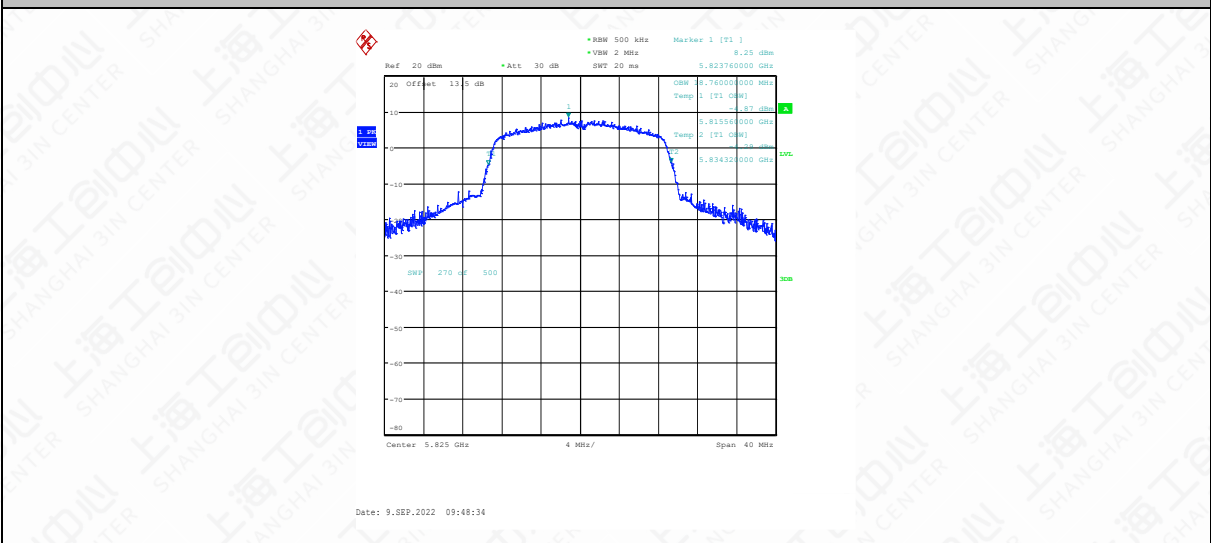

11N20SISO-Ant1-5825

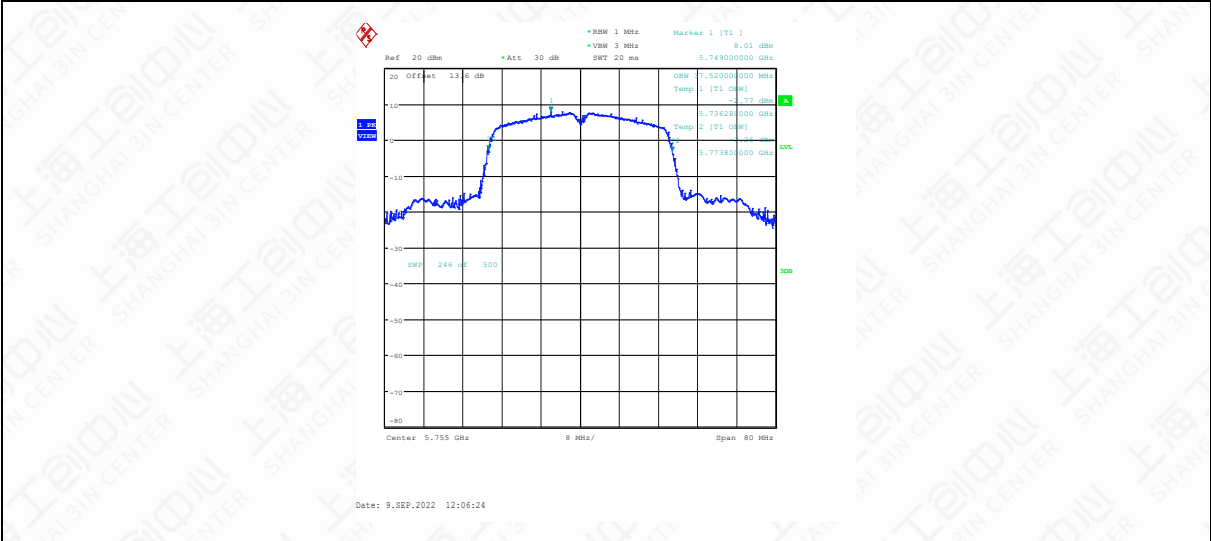

11N40SISO-Ant1-5755

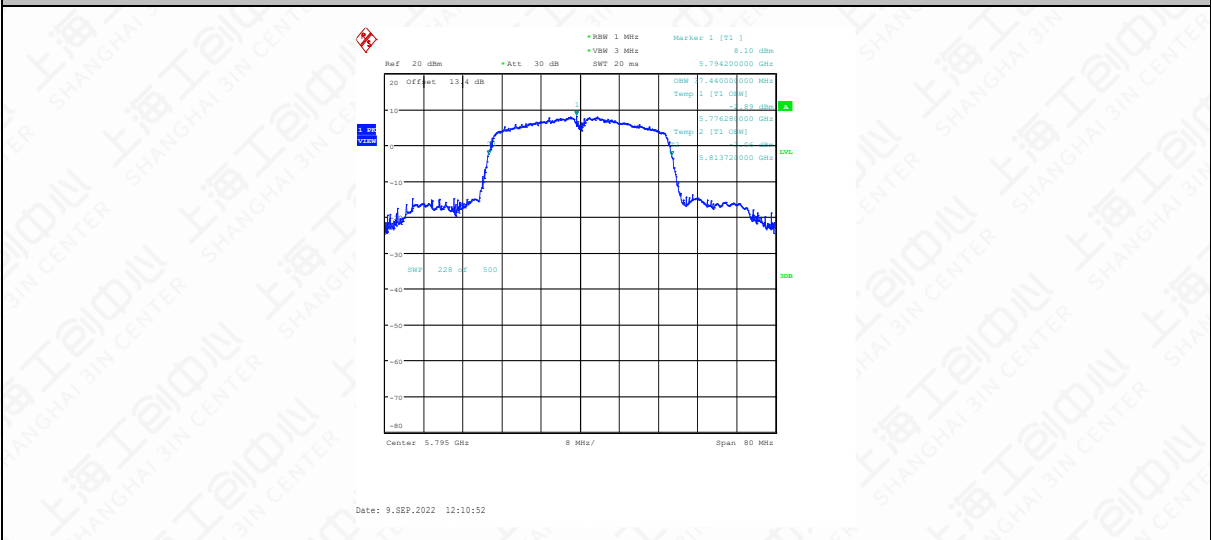

11N40SISO-Ant1-5795

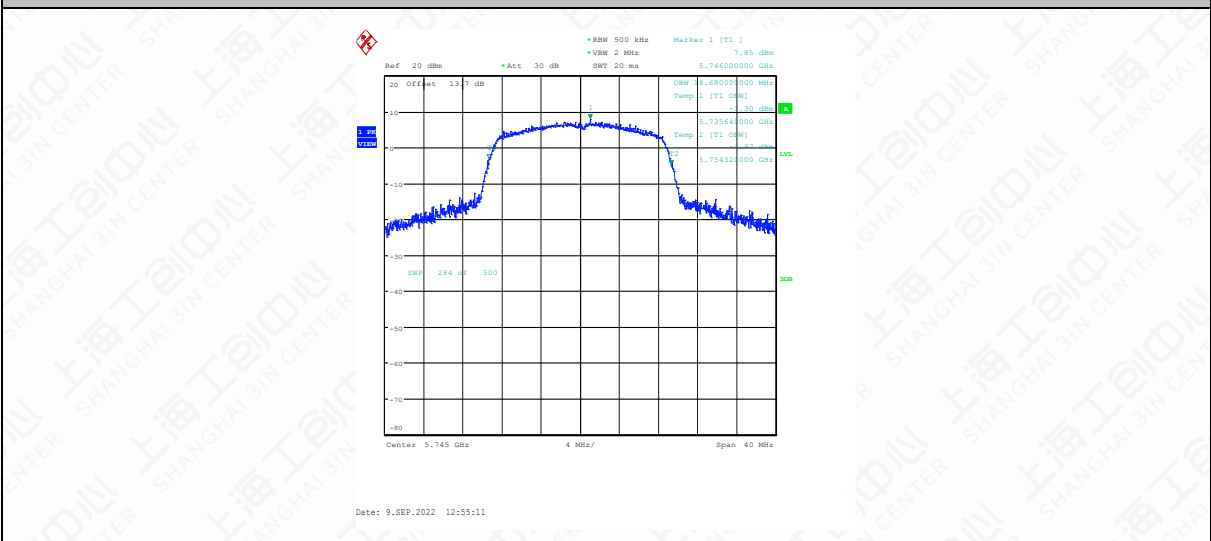

11AC20SISO-Ant1-5745



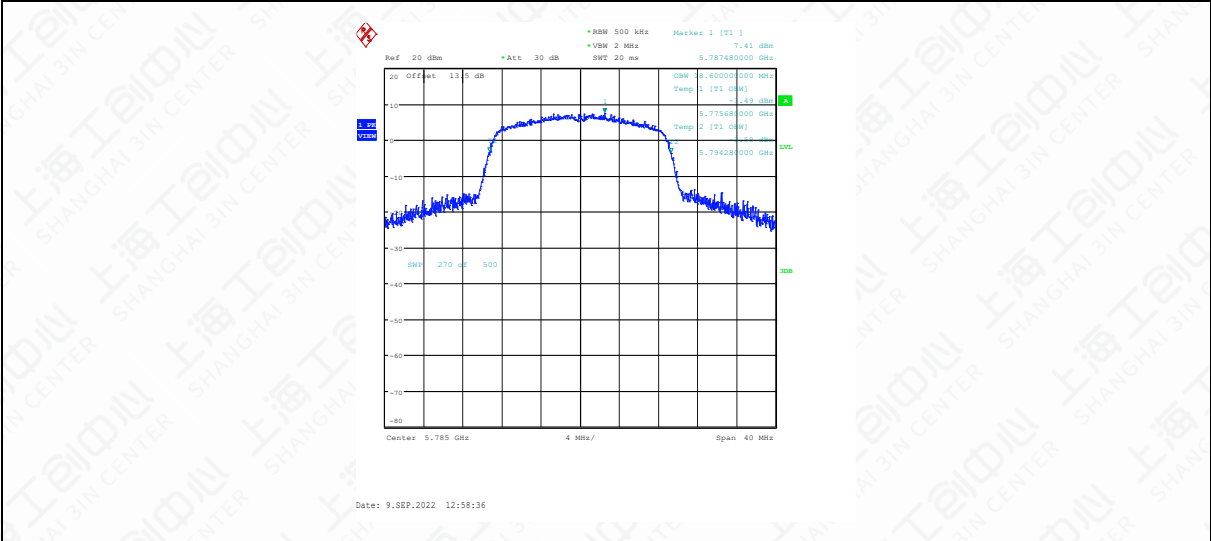

11AC20SISO-Ant1-5785

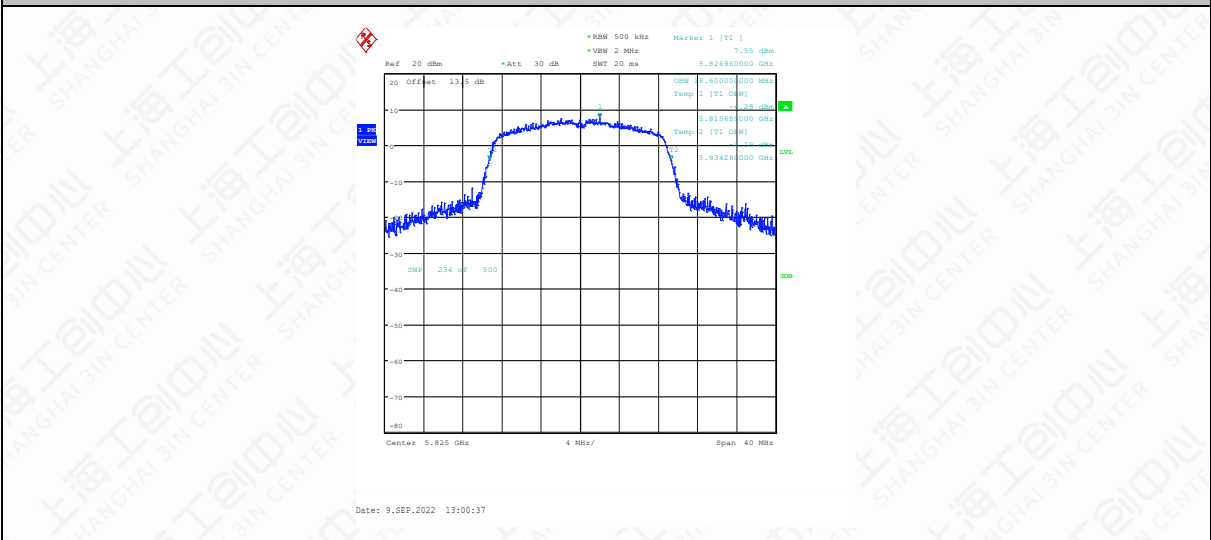

11AC20SISO-Ant1-5825

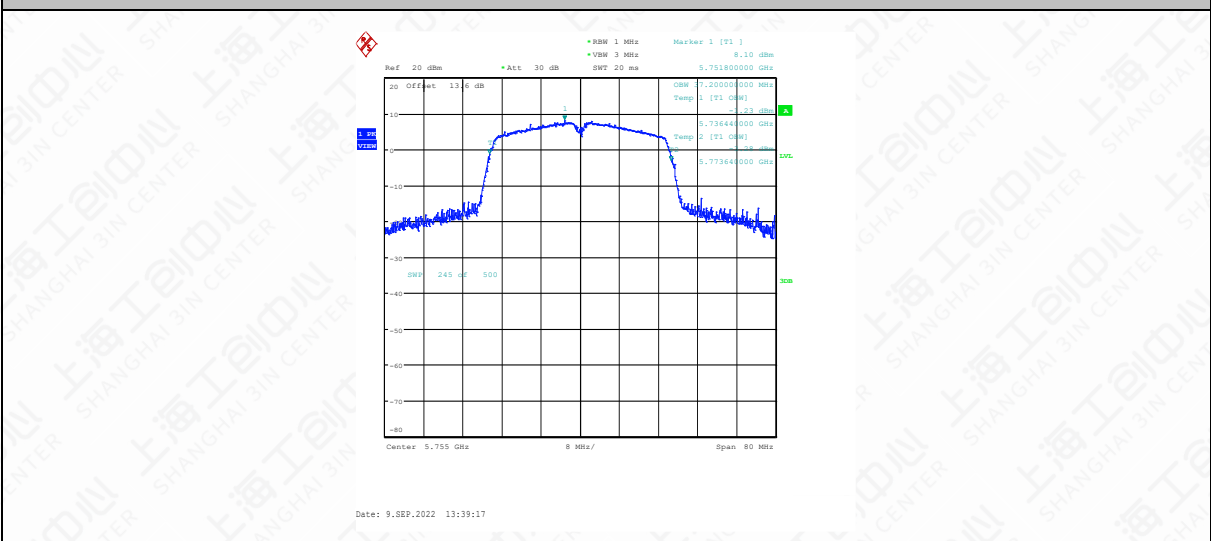

11AC40SISO-Ant1-5755

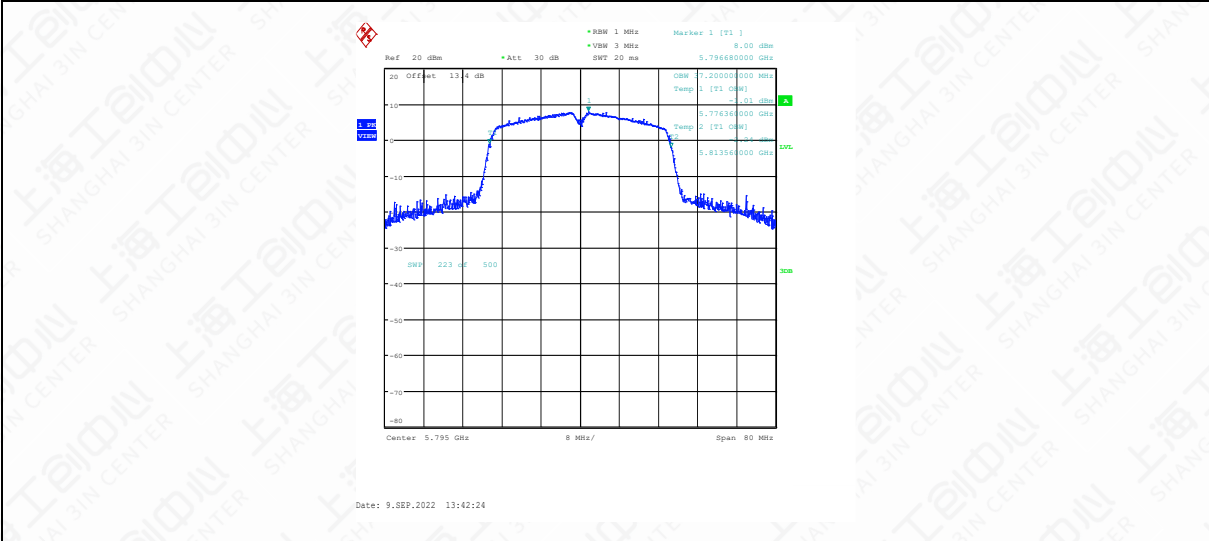

11AC40SISO-Ant1-5795

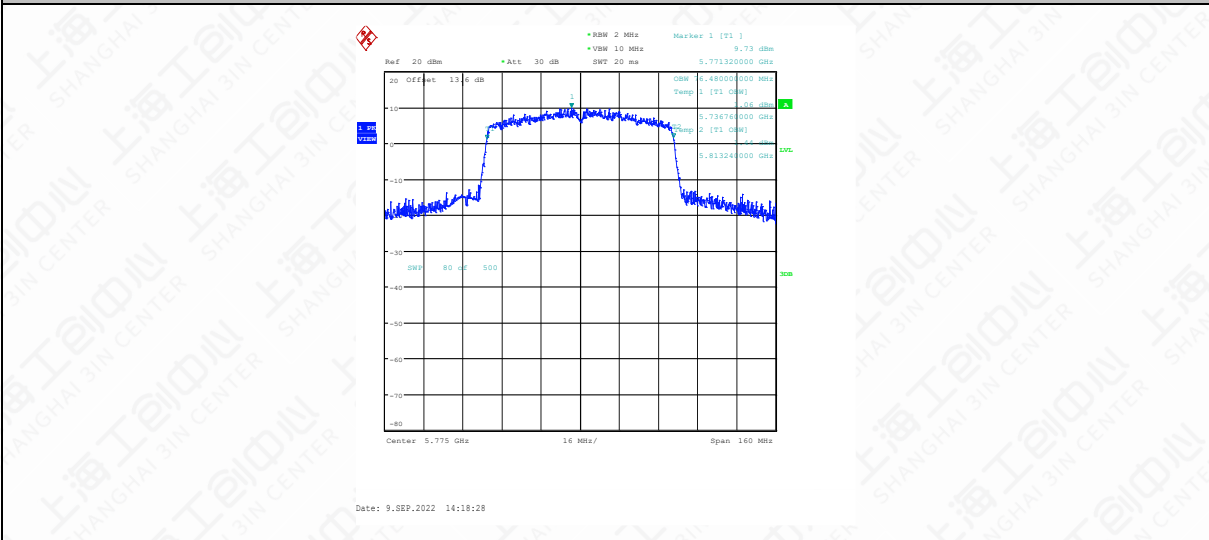

11AC80SISO-Ant1-5775

## 6.2 Min emission bandwidth

### 6.2.1 Measurement Limit and Method

Standard	Limit(KHz)
FCC 47 CFR Part 15.407(e)	≥500
RSS-247 6.2.4.1	≥500

The measurement is made according to KDB 789033 C

Section 15.407(e) specifies the minimum 6 dB emission bandwidth of at least 500 kHz for the band 5.725-5.85GHz. The following procedure shall be used for measuring this bandwidth:

- a) Set RBW= 100 kHz.
- b) Set the video bandwidth (VBW)  $\geq 3 \times$  RBW.
- c) Detector = Peak.
- d) Trace mode = max hold.
- e) Sweep = auto couple.
- f) Allow the trace to stabilize.
- g) Measure the maximum width of the emission that is constrained by the frequencies associated with the two outermost amplitude points (upper and lower frequencies) that are attenuated by 6 dB relative to the maximum level measured in the fundamental emission.

Note: The automatic bandwidth measurement capability of a spectrum analyzer or EMI receiver maybe employed if it implements the functionality described above.

### 6.2.2 Test Setup

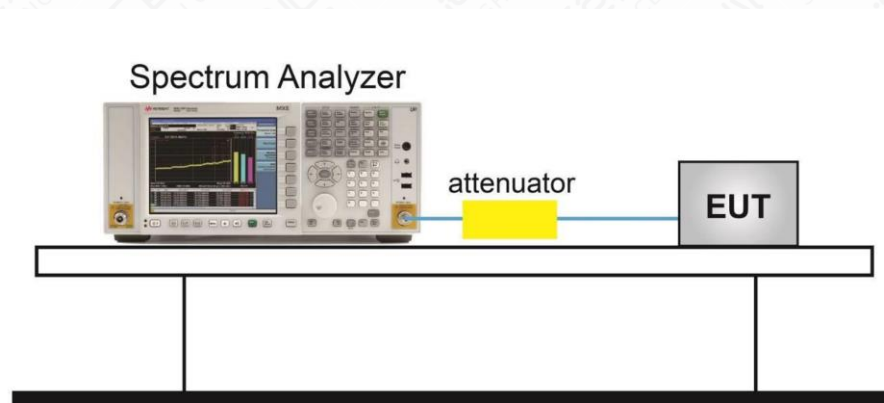

## 6.2.3 Test Result B4

TestMode	Antenna	Frequency[MHz]	6db EBW [MHz]	FL[MHz]	FH[MHz]
11A	Ant1	5745	15.04	5737.48	5752.52
11A	Ant1	5785	15.08	5777.40	5792.48
11A	Ant1	5825	15.08	5817.40	5832.48
11N20SISO	Ant1	5745	15.12	5737.40	5752.52
11N20SISO	Ant1	5785	15.04	5777.44	5792.48
11N20SISO	Ant1	5825	15.08	5817.44	5832.52
11N40SISO	Ant1	5755	35.12	5737.40	5772.52
11N40SISO	Ant1	5795	35.12	5777.40	5812.52
11AC20SISO	Ant1	5745	13.88	5738.64	5752.52
11AC20SISO	Ant1	5785	15.00	5777.52	5792.52
11AC20SISO	Ant1	5825	15.08	5817.44	5832.52
11AC40SISO	Ant1	5755	35.12	5737.40	5772.52
11AC40SISO	Ant1	5795	35.12	5777.40	5812.52
11AC80SISO	Ant1	5775	75.20	5737.40	5812.60

6.2.4 Test Graphs B4

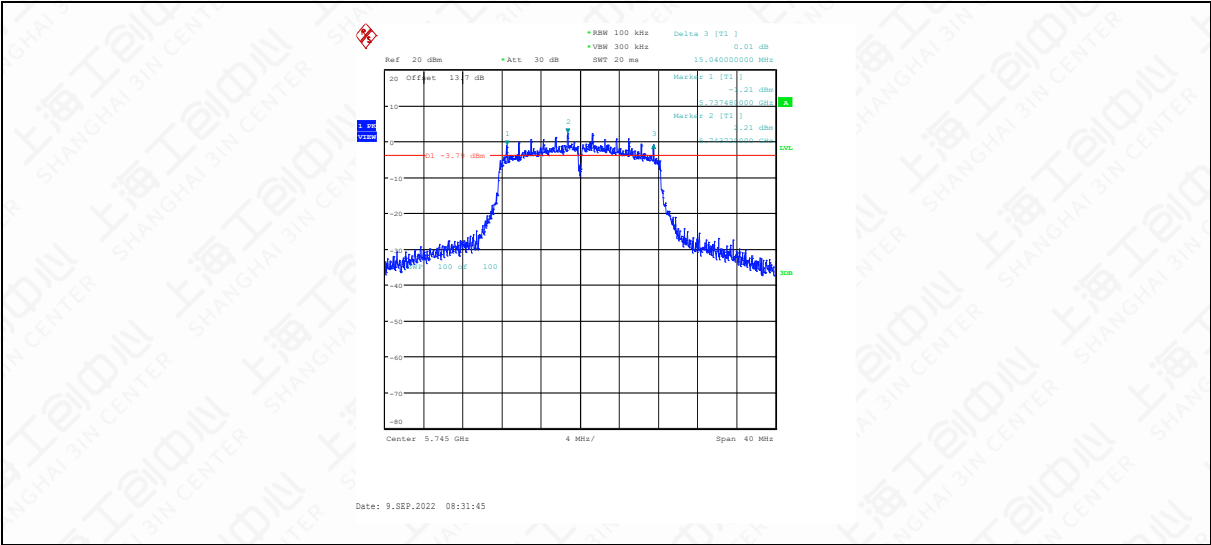

11A-Ant1-5745

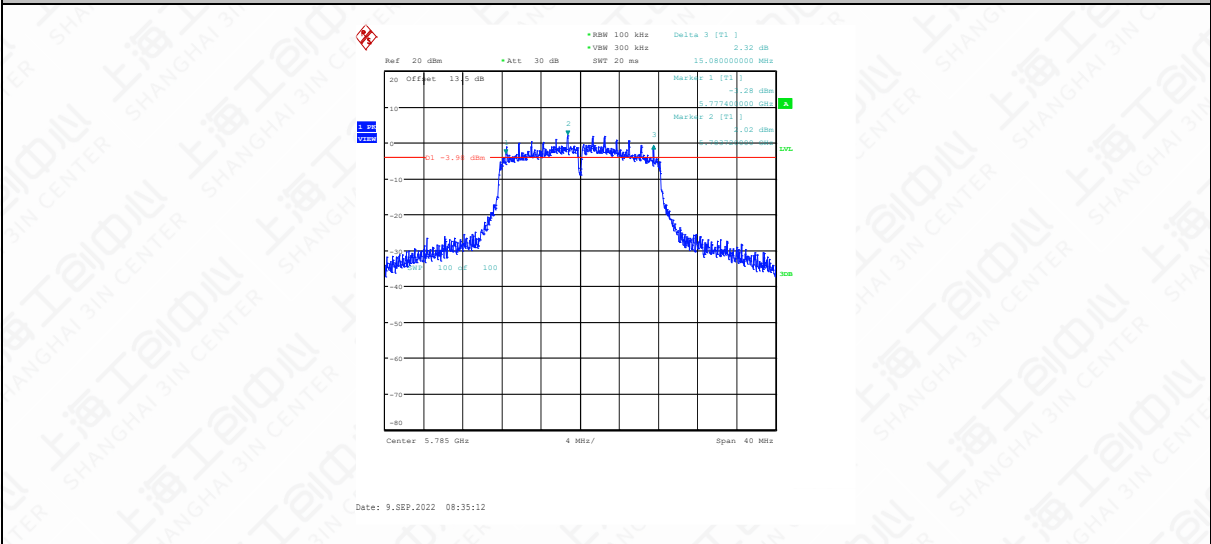

11A-Ant1-5785

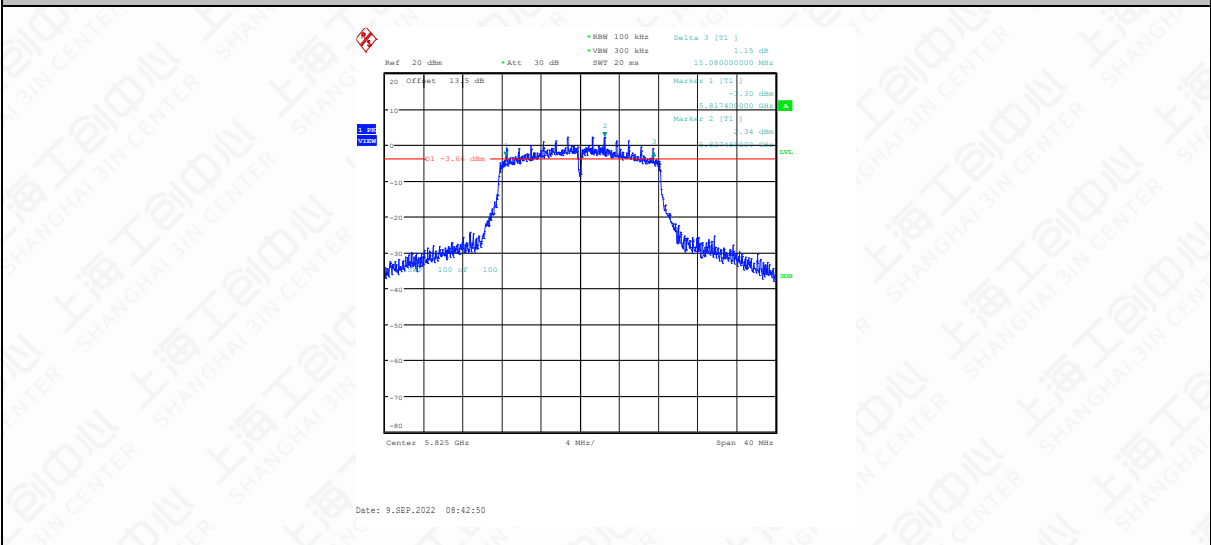

11A-Ant1-5825

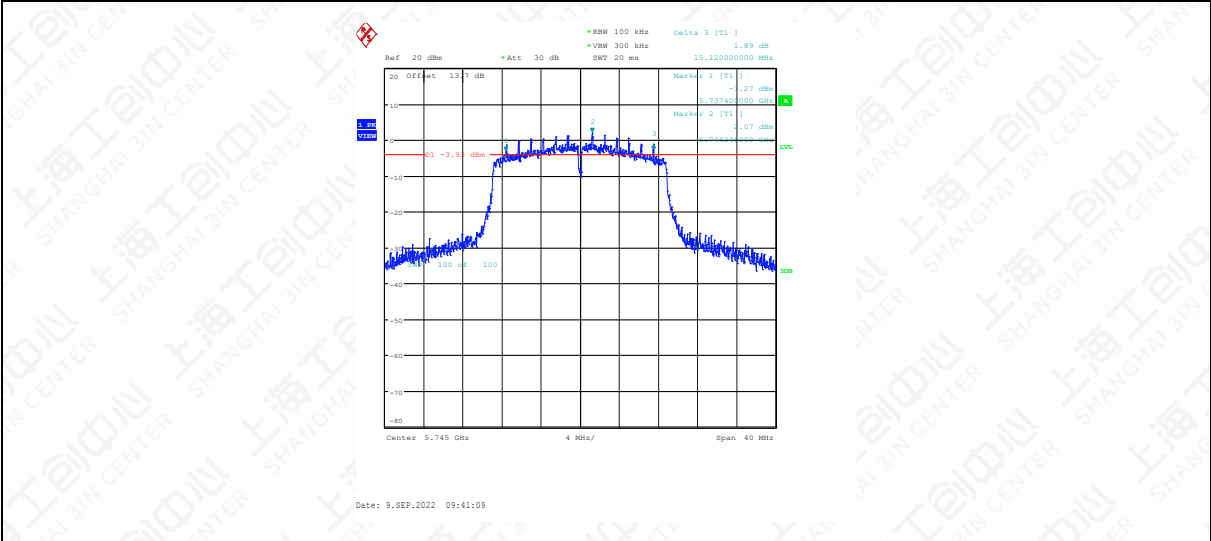

11N20SISO-Ant1-5745

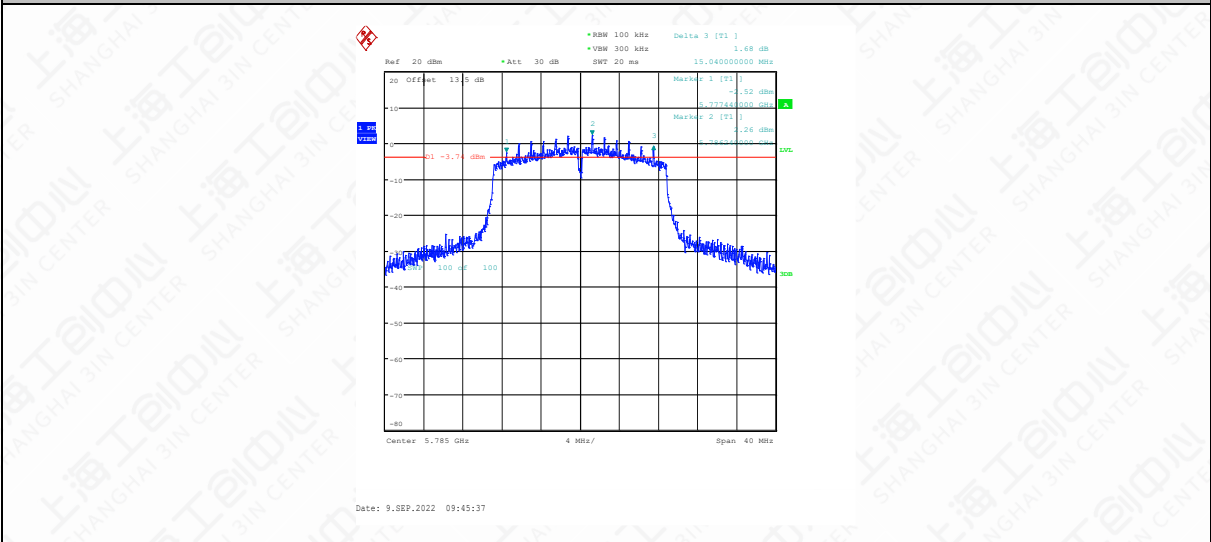

11N20SISO-Ant1-5785

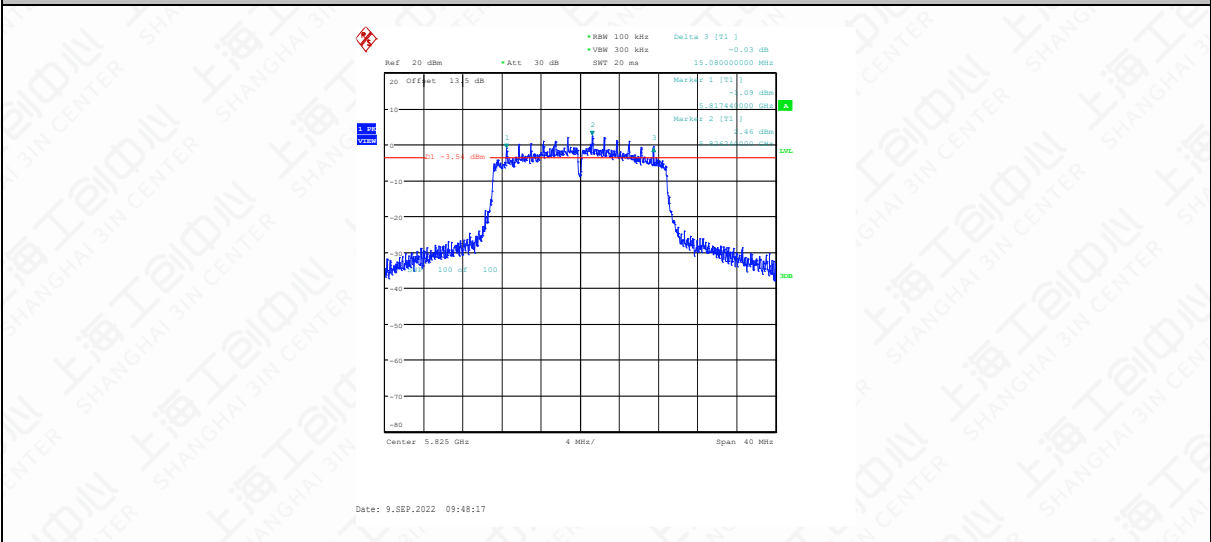

11N20SISO-Ant1-5825

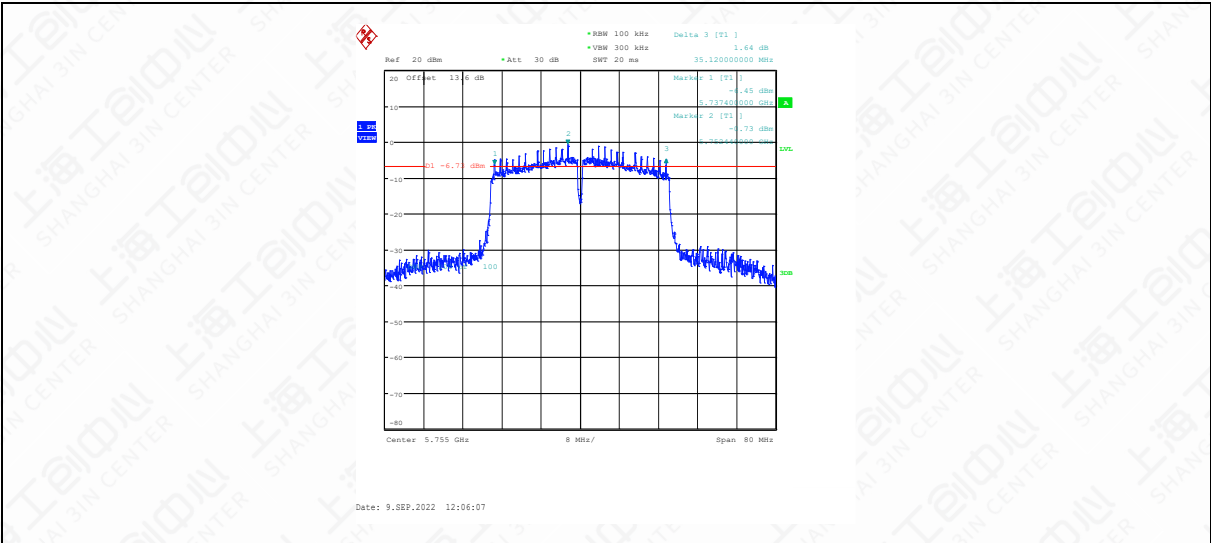

11N40SISO-Ant1-5755

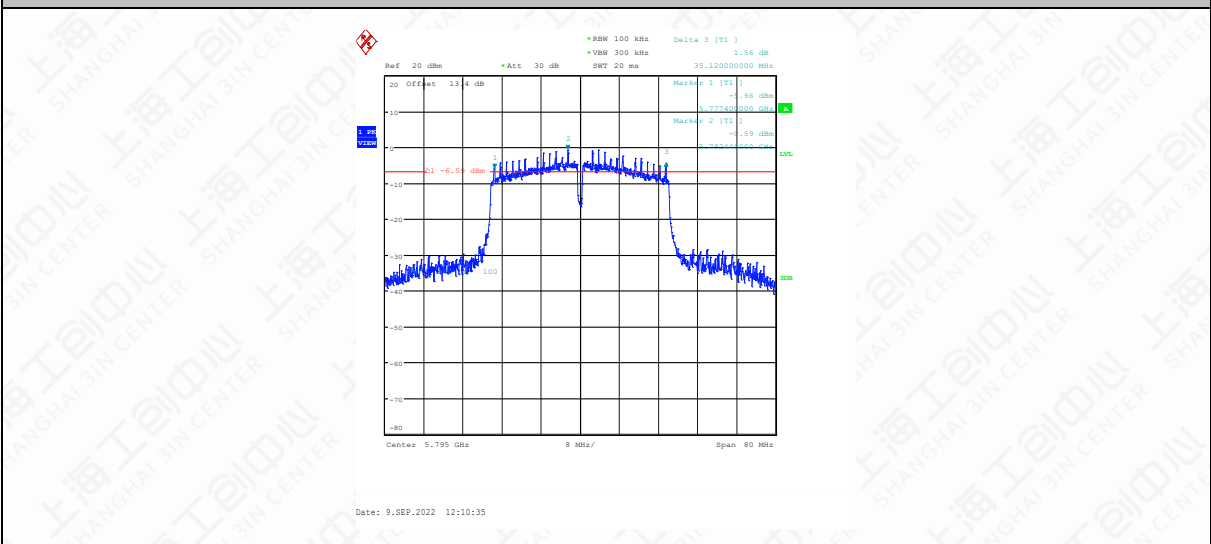

11N40SISO-Ant1-5795

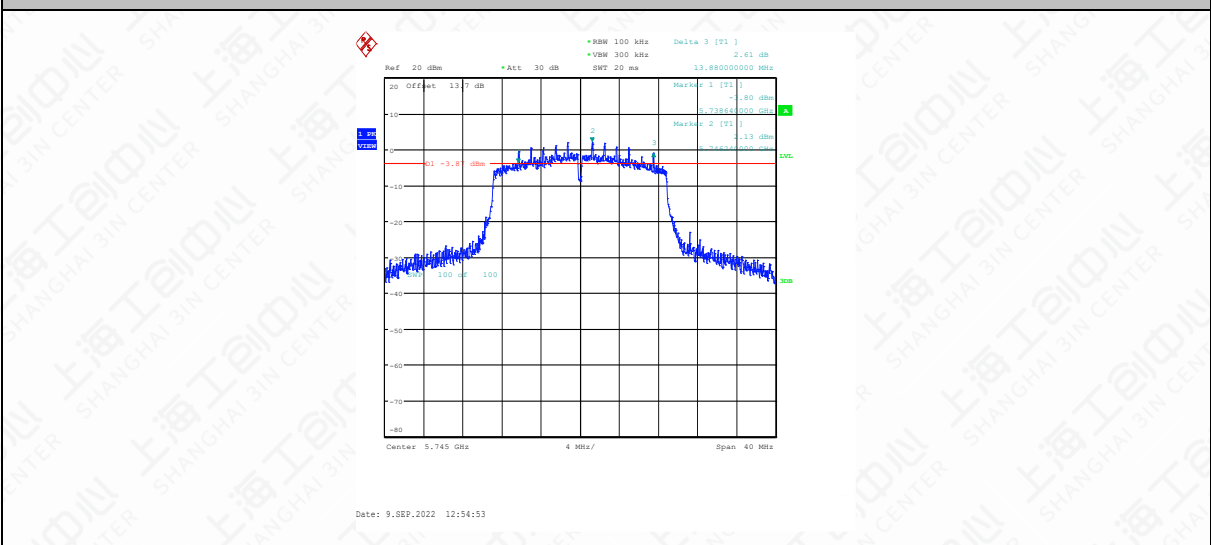

11AC20SISO-Ant1-5745

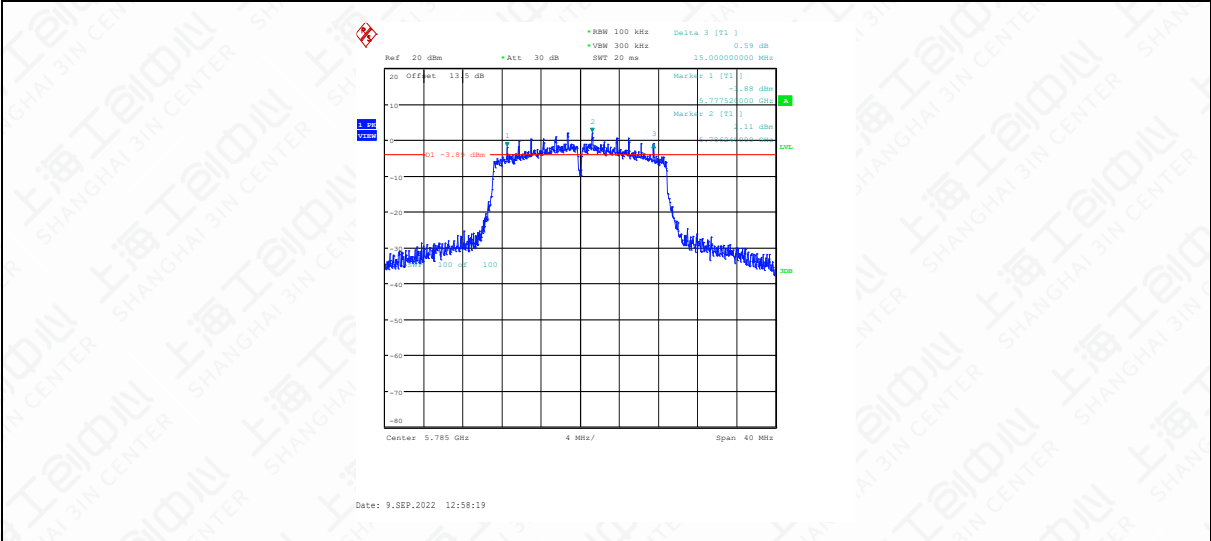

11AC20SISO-Ant1-5785

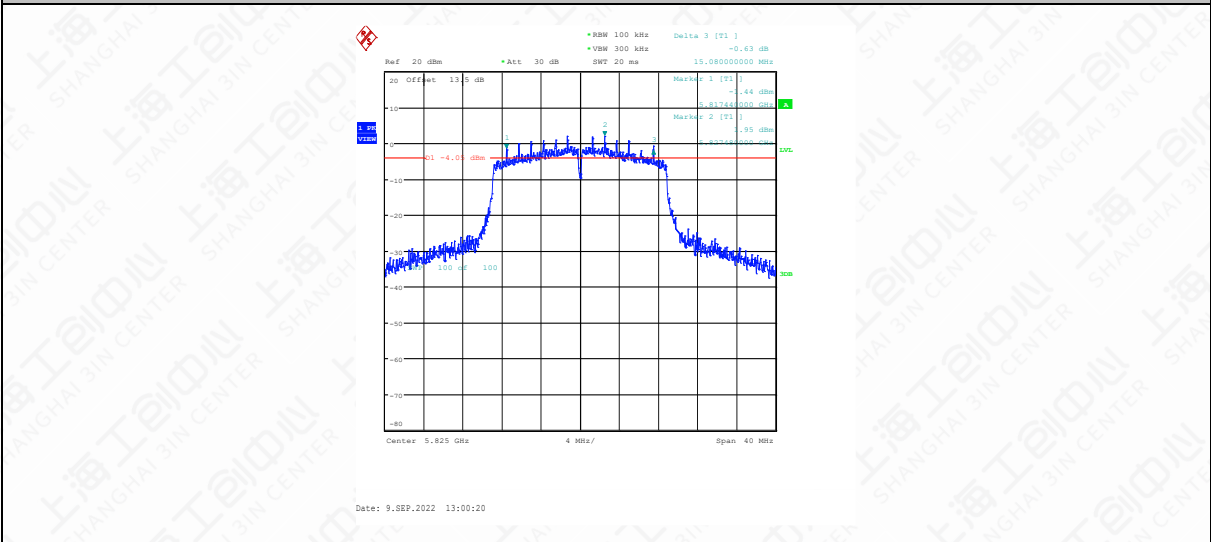

11AC20SISO-Ant1-5825

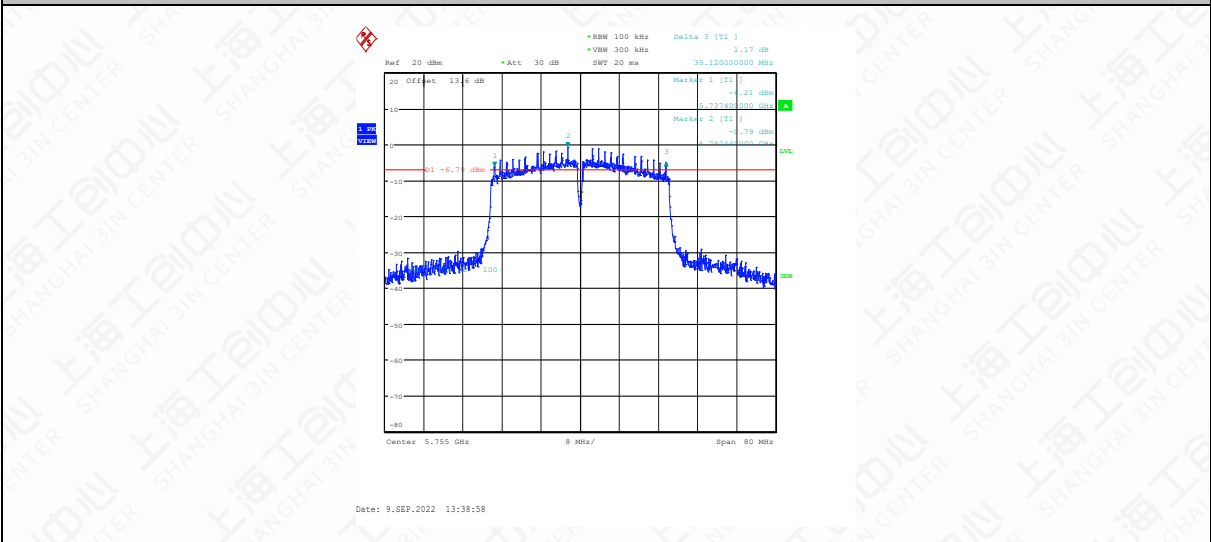

11AC40SISO-Ant1-5755



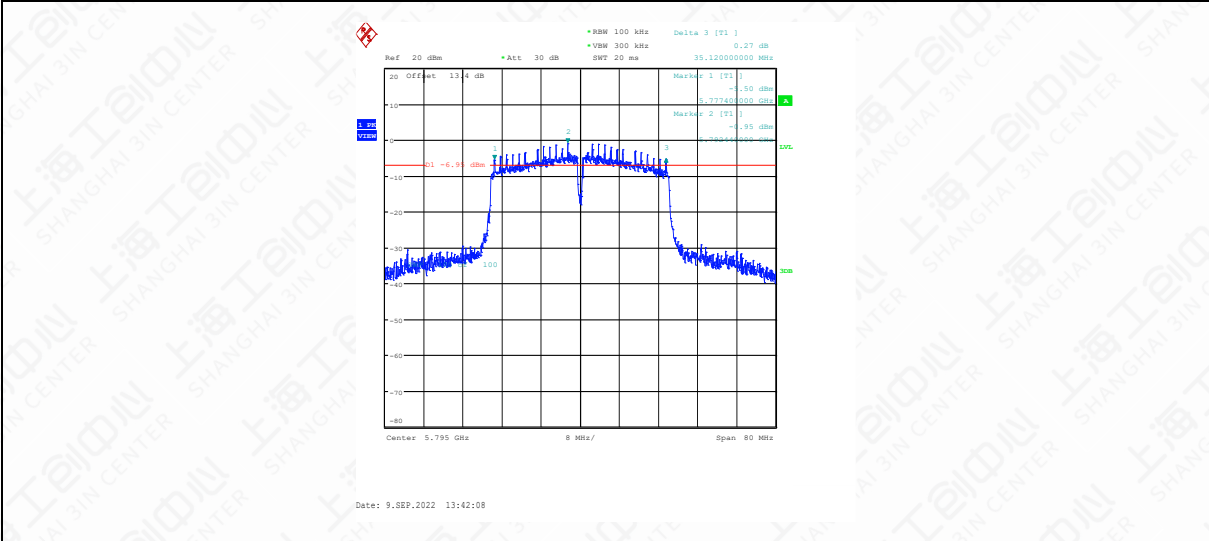

11AC40SISO-Ant1-5795

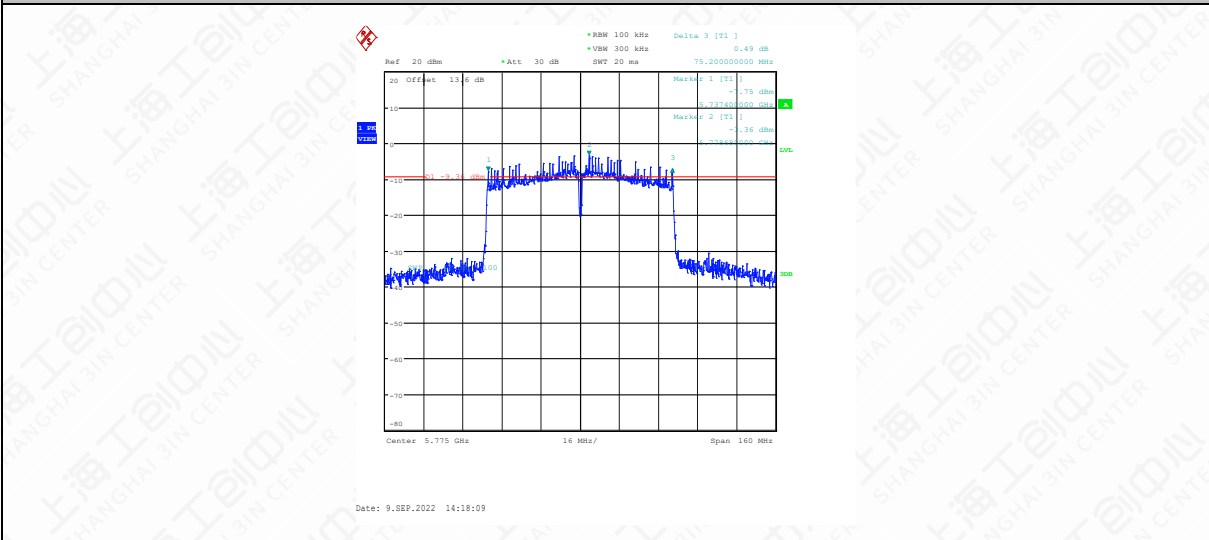

11AC80SISO-Ant1-5775

### 6.3 Maximum conducted output power

#### 6.3.1 Measurement Limit and Method

Standard	Limit (dBm)
FCC CRF Part 15.407(a)	< 30
RSS-247 6.2.4.1	< 30

The measurement method SA-1 is made according to KDB 789033 E

1. Set span to encompass the entire emission bandwidth (EBW) (or, alternatively, the entire 99% occupied bandwidth) of the signal.
2. Set RBW=1MHz
3. Set VBW≥3MHz
4. Number of points in sweep  $\geq 2 \times \text{span} / \text{RBW}$ . (This ensures that bin-to-bin spacing is  $\leq \text{RBW}/2$ , so that narrowband signals are not lost between frequency bins.)
5. Sweep time = auto.
6. Detector = power averaging (rms), if available. Otherwise, use sample detector mode.
7. If transmit duty cycle < 98%, use a video trigger with the trigger level set to enable triggering only on full power pulses. Transmitter must operate at maximum power control level for the entire duration of every sweep. If the EUT transmits continuously (i.e., with no off intervals) or at duty cycle  $\geq 98\%$ , and if each transmission is entirely at the maximum power control level, then the trigger shall be set to “free run.”
8. Trace average at least 100 traces in power averaging (rms) mode.
9. Compute power by integrating the spectrum across the EBW (or, alternatively, the entire 99% occupied bandwidth) of the signal using the instrument’s band power measurement function with band limits set equal to the EBW (or occupied bandwidth) band edges. If the instrument does not have a band power function, sum the spectrum levels (in power units) at 1 MHz intervals extending across the EBW (or, alternatively, the entire 99% occupied bandwidth) of the spectrum.

### 6.3.2 Test setup

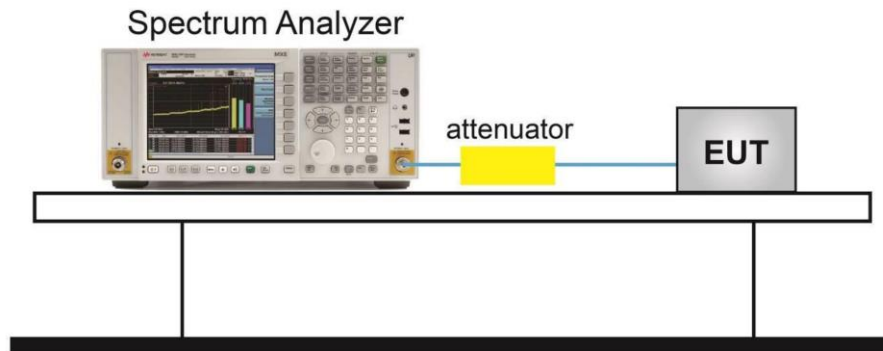

### 6.3.3 Test Result Channel Power

Test Mode	Tx power level	Frequency [MHz]	Channel Power [dBm]	Duty Cycle [%]	DC Factor [dBm]	Result [dBm]	Limit [dBm]	EIRP [dBm]
11A	19	5745	12.85	97.22	0.12	12.97	≤30.00	16.28
11A	19	5785	12.57	96.53	0.15	12.72	≤30.00	16.03
11A	19	5825	12.61	96.53	0.15	12.76	≤30.00	16.07
11N20SISO	19	5745	12.47	96.30	0.16	12.63	≤30.00	15.94
11N20SISO	19	5785	12.39	97.01	0.13	12.52	≤30.00	15.83
11N20SISO	19	5825	12.47	96.30	0.16	12.63	≤30.00	15.94
11N40SISO	19	5755	11.96	94.20	0.26	12.22	≤30.00	15.53
11N40SISO	19	5795	12.11	94.20	0.26	12.37	≤30.00	15.68
11AC20SISO	19	5745	12.45	96.32	0.16	12.61	≤30.00	15.92
11AC20SISO	19	5785	12.37	97.04	0.13	12.50	≤30.00	15.81
11AC20SISO	19	5825	12.27	97.04	0.13	12.40	≤30.00	15.71
11AC40SISO	19	5755	11.98	94.29	0.26	12.24	≤30.00	15.55
11AC40SISO	19	5795	11.97	94.20	0.26	12.23	≤30.00	15.54
11AC80SISO	19	5775	12.18	86.49	0.63	12.81	≤30.00	16.12

Note: The Duty Cycle Factor is compensated in the graph.

6.3.4 Test Graphs Channel Power

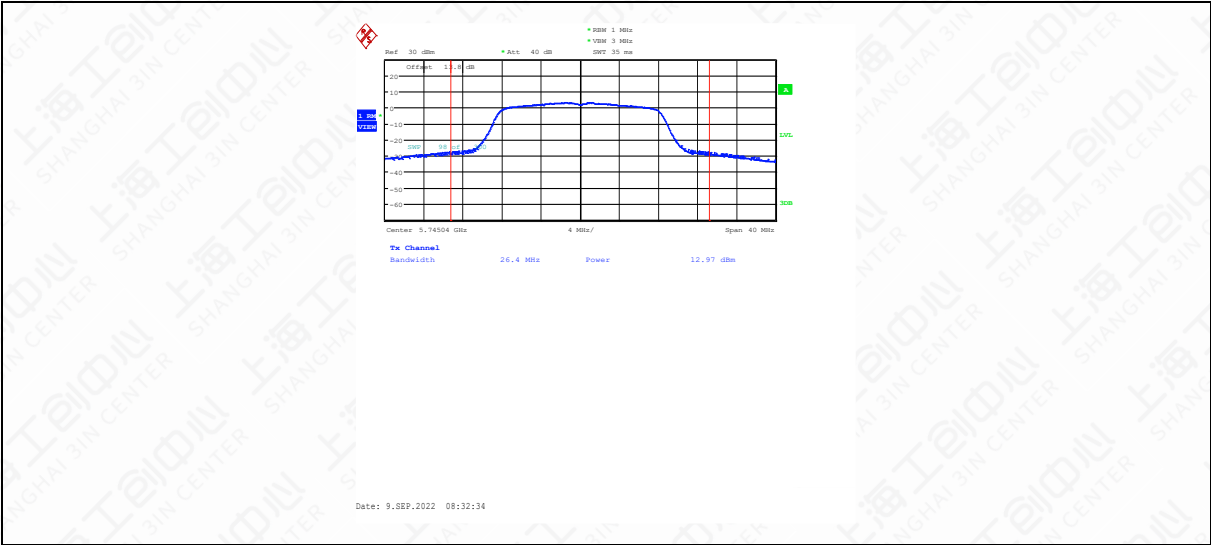

11A-Ant1-5745-----12.85-97.22-0.12

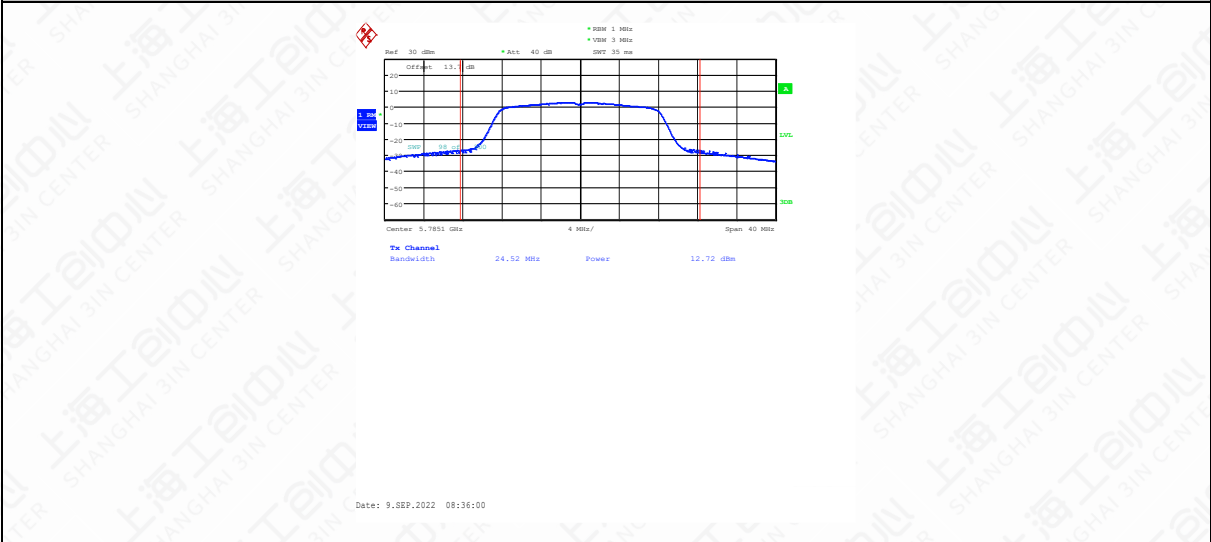

11A-Ant1-5785-----12.57-96.53-0.15

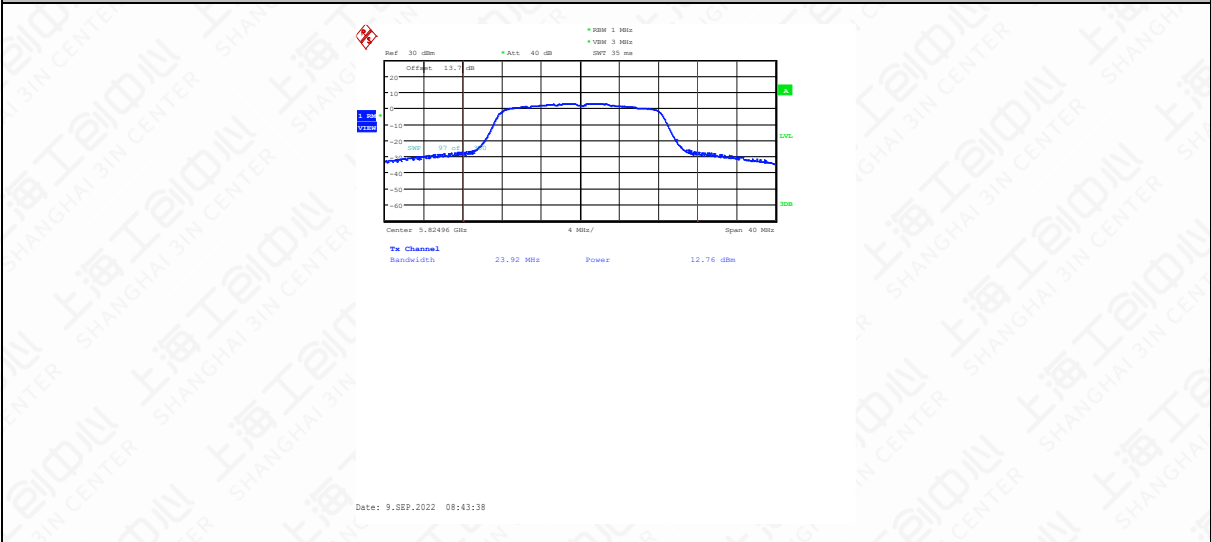

11A-Ant1-5825-----12.61-96.53-0.15

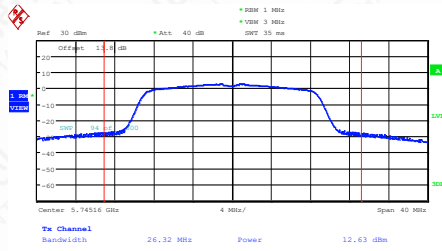

Date: 9,SEP,2022 09:41:58

11N20SISO-Ant1-5745-----12.47-96.30-0.16

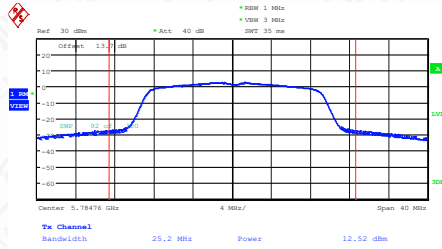

Date: 9,SEP,2022 09:46:26

11N20SISO-Ant1-5785-----12.39-97.01-0.13

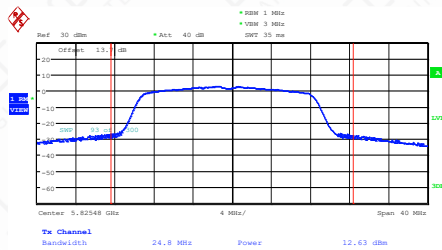

Date: 9,SEP,2022 09:49:05

11N20SISO-Ant1-5825-----12.47-96.30-0.16

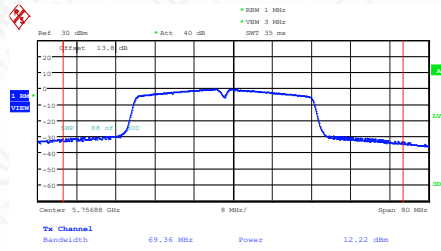

Date: 9,SEP,2022 12:06:55

11N40SISO-Ant1-5755-----11.96-94.20-0.26

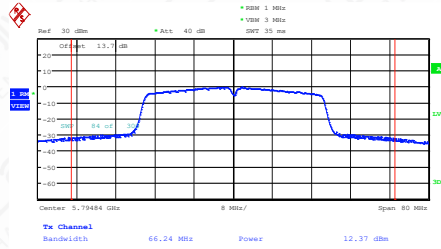

Date: 9,SEP,2022 12:11:23

11N40SISO-Ant1-5795-----12.11-94.20-0.26

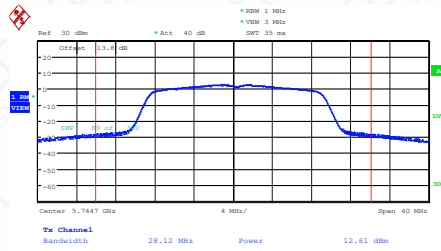

Date: 9,SEP,2022 12:55:43

11AC20SISO-Ant1-5745-----12.45-96.32-0.16

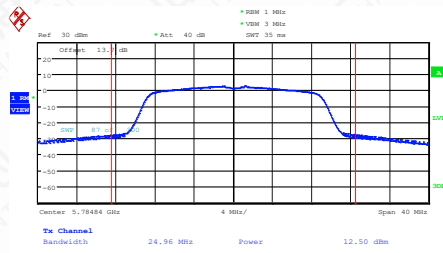

Date: 9,SEP,2022 12:59:08

11AC20SISO-Ant1-5785-----12.37-97.04-0.13

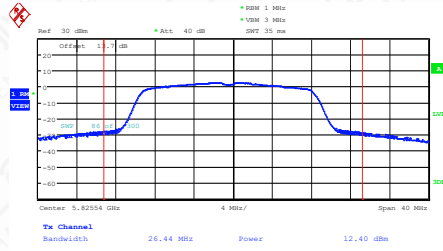

Date: 9,SEP,2022 13:01:07

11AC20SISO-Ant1-5825-----12.27-97.04-0.13

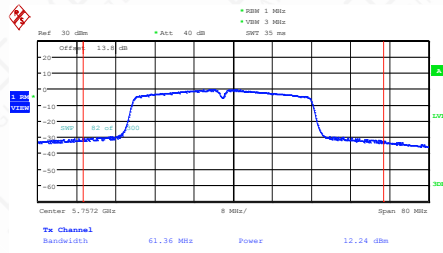

Date: 9,SEP,2022 13:39:48

11AC40SISO-Ant1-5755-----11.98-94.29-0.26

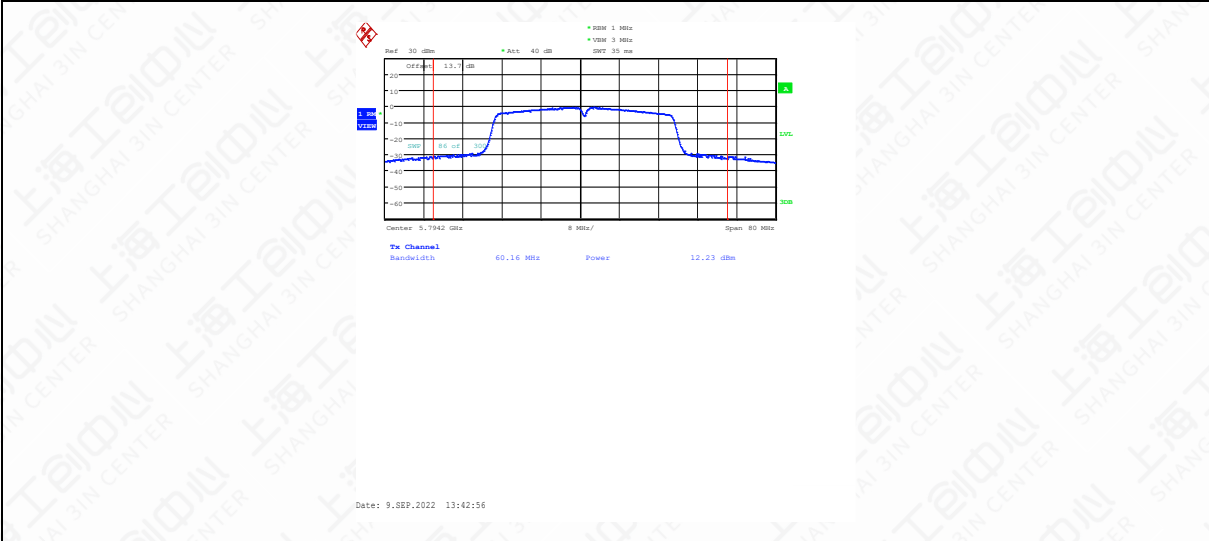

11AC40SISO-Ant1-5795-----11.97-94.20-0.26

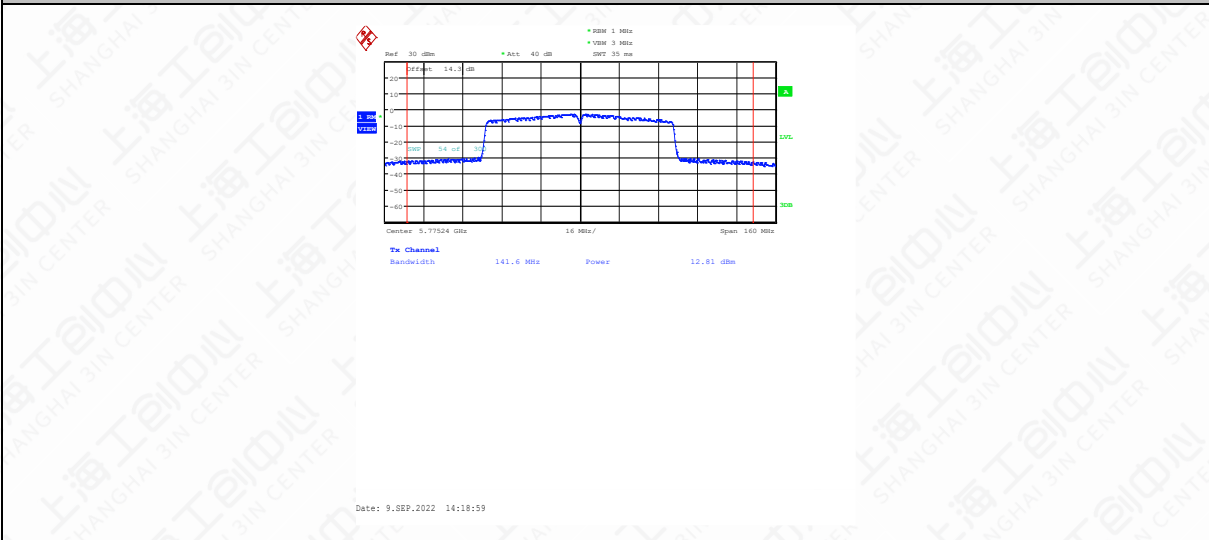

11AC80SISO-Ant1-5775-----12.18-86.49-0.63



## 6.4 Maximum power spectral density

### 6.4.1 Measurement Limit and Method

Standard	Limit
FCC 47 CFR Part 15.407(a)	< 30 dBm/500 kHz
RSS-247 6.2.4.1	< 30 dBm/500 kHz

The measurement method is made according to KDB 789033 F

1. Create an average power spectrum for the EUT operating mode being tested by following the instructions in II.E.2. for measuring maximum conducted output power using a spectrum analyzer or EMI receiver: select the appropriate test method (SA-1, SA-2, SA-3, or alternatives to each) and apply it up to, but not including, the step labeled, "Compute power..." (This procedure is required even if the maximum conducted output power measurement was performed using a power meter, method PM.)
2. Use the peak search function on the instrument to find the peak of the spectrum and record its value.
3. Make the following adjustments to the peak value of the spectrum, if applicable:
  - a) If Method SA-2 or SA-2 Alternative was used, add  $10 \log(1/x)$ , where  $x$  is the duty cycle, to the peak of the spectrum.
  - b) If Method SA-3 Alternative was used and the linear mode was used in step II.E.2.g)(viii), add 1 dB to the final result to compensate for the difference between linear averaging and power averaging.
4. The result is the Maximum PSD over 1 MHz reference bandwidth.
5. For devices operating in the bands 5.15-5.25 GHz, 5.25-5.35 GHz, and 5.47-5.725 GHz, the above procedures make use of 1 MHz RBW to satisfy directly the 1 MHz reference bandwidth specified in Section 15.407(a)(5). For devices operating in the band 5.725-5.85 GHz, the rules specify a measurement bandwidth of 500 kHz. Many spectrum analyzers do not have 500 kHz RBW, thus a narrower RBW may need to be used. The rules permit the use of a RBWs less than 1 MHz, or 500 kHz, "provided that the measured power is integrated over the full reference bandwidth" to show the total power over the specified measurement bandwidth (i.e., 1 MHz, or 500 kHz). If measurements are performed using a reduced resolution bandwidth (< 1 MHz, or < 500 kHz) and integrated over 1 MHz, or 500 kHz bandwidth, the following adjustments to the procedures apply:
  - a) Set  $RBW \geq 1/T$ , where  $T$  is defined in II.B.I.a).
  - b) Set  $VBW \geq 3 RBW$ .

c) If measurement bandwidth of Maximum PSD is specified in 500 kHz, add  $10 \log (500 \text{ kHz}/\text{RBW})$  to the measured result, whereas RBW (<500 kHz) is the reduced resolution bandwidth of the spectrum analyzer set during measurement.

d) If measurement bandwidth of Maximum PSD is specified in 1 MHz, add  $10 \log (1\text{MHz}/\text{RBW})$  to the measured result, whereas RBW (< 1 MHz) is the reduced resolution bandwidth of spectrum analyzer set during measurement.

e) Care must be taken to ensure that the measurements are performed during a period of continuous transmission or are corrected upward for duty cycle.

Note: As a practical matter, it is recommended to use reduced RBW of 100 kHz for steps 5.c) and 5.d) above, since RBW=100 KHZ is available on nearly all spectrum analyzers.

#### 6.4.2 Test setup

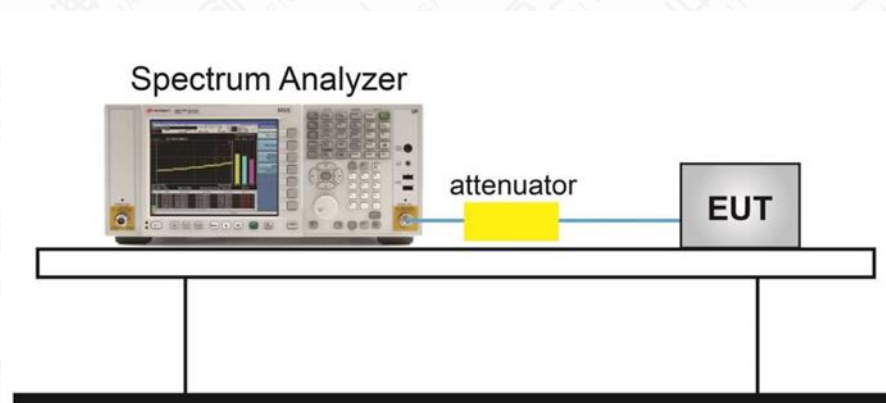

## 6.4.3 Test Result

TestMode	Antenna	Frequency[MHz]	Result [dBm/MHz]	Limit[dBm/MHz]	Verdict
11A	Ant1	5745	-0.07	≤30.00	PASS
11A	Ant1	5785	-0.38	≤30.00	PASS
11A	Ant1	5825	-0.19	≤30.00	PASS
11N20SISO	Ant1	5745	-0.69	≤30.00	PASS
11N20SISO	Ant1	5785	-0.83	≤30.00	PASS
11N20SISO	Ant1	5825	-0.59	≤30.00	PASS
11N40SISO	Ant1	5755	-4.06	≤30.00	PASS
11N40SISO	Ant1	5795	-3.87	≤30.00	PASS
11AC20SISO	Ant1	5745	-0.82	≤30.00	PASS
11AC20SISO	Ant1	5785	-0.81	≤30.00	PASS
11AC20SISO	Ant1	5825	-0.81	≤30.00	PASS
11AC40SISO	Ant1	5755	-3.99	≤30.00	PASS
11AC40SISO	Ant1	5795	-3.92	≤30.00	PASS
11AC80SISO	Ant1	5775	-6.46	≤30.00	PASS

Note: 1.The Result and Limit Unit is dBm/500 kHz in the band 5.725–5.85 GHz.

2.The Duty Cycle Factor and RBW Factor is compensated in the graph.

## 6.4.4 Test Graphs



11A-Ant1-5745--0.19-0.12-0.00-0.00



11A-Ant1-5785--0.53-0.15-0.00-0.00



11A-Ant1-5825--0.34-0.15-0.00-0.00



11N20SISO-Ant1-5745--0.85-0.16-0.00-0.00

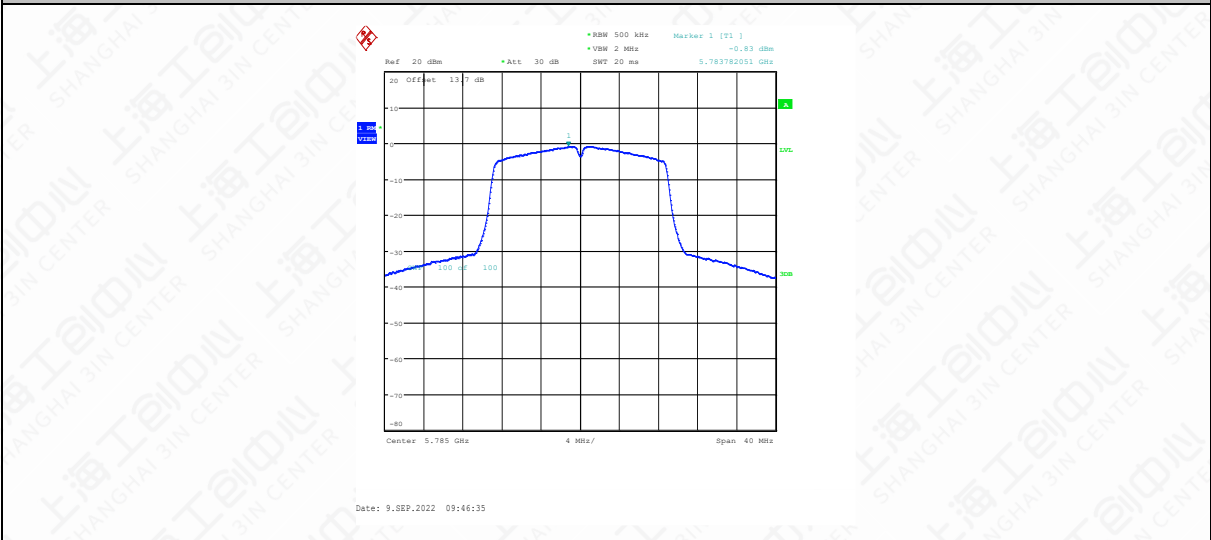

11N20SISO-Ant1-5785--0.96-0.13-0.00-0.00



11N20SISO-Ant1-5825--0.75-0.16-0.00-0.00



11N40SISO-Ant1-5755--4.32-0.26-0.00-0.00



11N40SISO-Ant1-5795--4.13-0.26-0.00-0.00



11AC20SISO-Ant1-5745--0.98-0.16-0.00-0.00



11AC20SISO-Ant1-5785--0.94-0.13-0.00-0.00



11AC20SISO-Ant1-5825--0.94-0.13-0.00-0.00

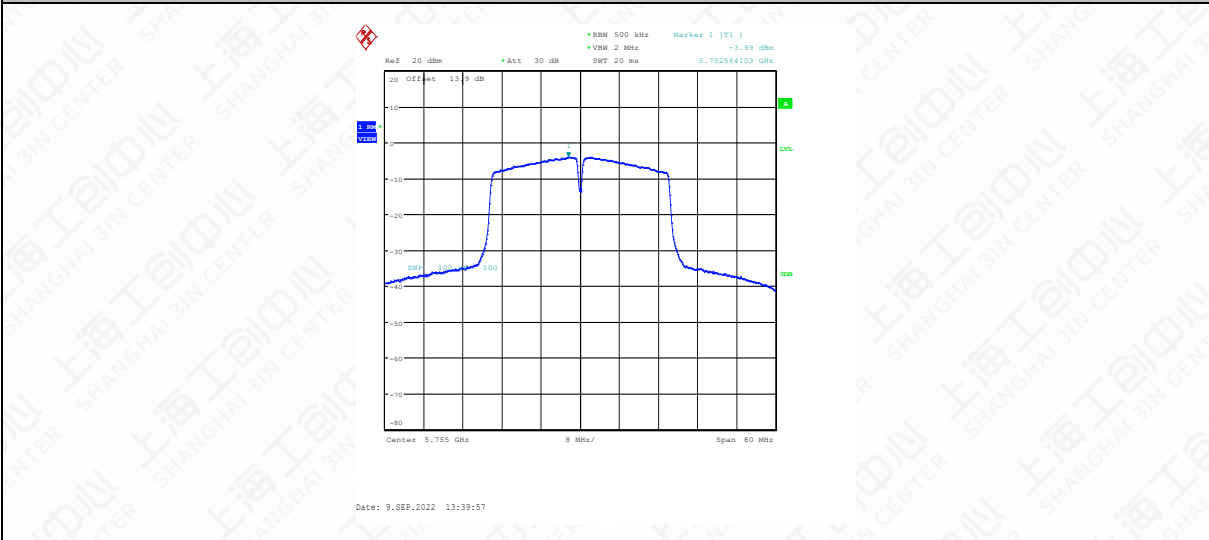

11AC40SISO-Ant1-5755--4.25-0.26-0.00-0.00



11AC40SISO-Ant1-5795--4.18-0.26-0.00-0.00

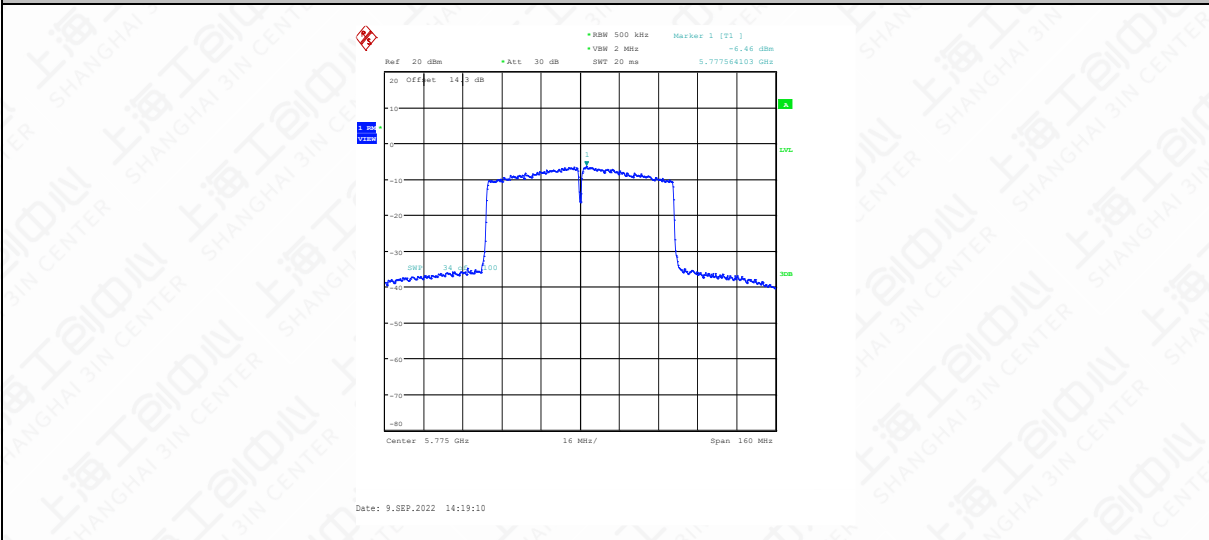

11AC80SISO-Ant1-5775--7.09-0.63-0.00-0.00



## 6.5 Frequency Stability

Manufacturers ensured the EUT meet the requirement of frequency stability, such that an emission is maintained within the band of operation under all conditions of normal operation as specified in the user's manual.(According to15.407(g))

## 6.6 Transmitter Spurious Emission

### 6.6.1 Transmitter Spurious Emission - Radiated

The measurement is made according to ANSI C63.10.

Frequency of emission (MHz)	Field strength(uV/m)	Field strength(dBuV/m)
0.009-0.490	2400/F(kHz)	129-94
0.490-1.705	24000/F(kHz)	74-63
1.705-30	30	70
30-88	100	40
88-216	150	43.5
216-960	200	46
Above 960	500	54

### 6.6.2 Test procedures

The measurement was applied in a semi-anechoic chamber. While testing for spurious emission higher than 1GHz, if applied, the pre-amplifier would be equipped just at the output terminal of the antenna.

Tabletop devices shall be placed on a nonconducting platform with nominal top surface dimensions 1 m by 1.5 m. For emissions testing at or below 1 GHz, the table height shall be 80 cm above the reference ground plane. For emission measurements above 1 GHz, the table height shall be 1.5 m.

The turntable rotated 360 degrees to determine the position of the maximum emission level.

The EUT was set 3 meters away from the receiving antenna which was mounted on an antenna mast. The antenna moved up and down between from 1meter to 4 meters to find out the maximum emission level.

The EUT was tested according to KDB 789033 D02: Section G.

The radiated emission was measured using the Spectrum Analyzer with the resolutions bandwidth set as:

RBW = 300 Hz, VBW = 1 kHz (9 kHz~150 kHz);

RBW = 10 kHz, VBW = 30 kHz (150 kHz~30MHz);

RBW = 100 kHz, VBW = 300 kHz (30MHz~1GHz for PK)

RBW = 1MHz, VBW = 3MHz (>1GHz for PK);

Remark:

1. Factor= Antenna Factor + Cable Loss (-Amplifier, is employed)

2. Measured level= Original Receiver Reading + Factor
3. Margin = Limit – Measured level
4. If the PK measured level is lower than AV limit, the AV test can be elided. Modulation type and data rate tested (Only worst case result is given below):

Mainly Supply		
Mode	Data rate	Channel
802.11a	6Mbps	165(5825MHz)
802.11n-HT20	MCS0	157(5785MHz)
802.11n-HT40	MCS0	159(5795MHz)
802.11ac-HT20	MCS0	165(5825MHz)
802.11ac-HT40	MCS0	159(5795MHz)
802.11ac-HT80	MCS0	155(5775MHz)

Below 1GHz Test Setup

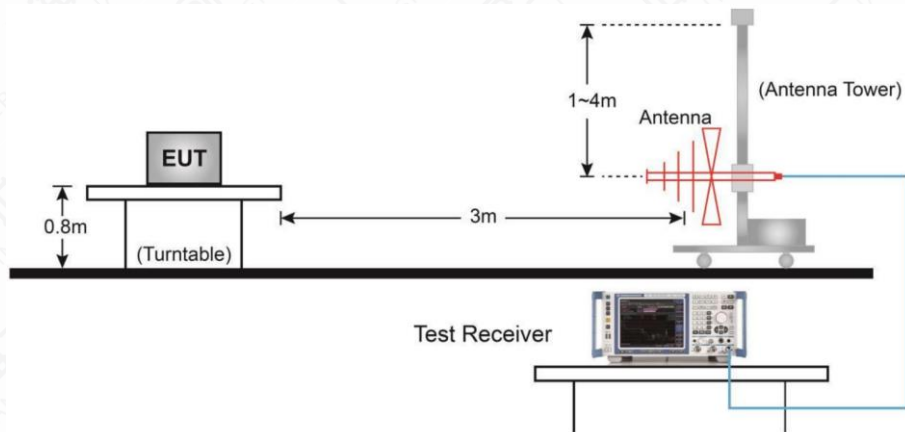

Above 1GHz Test Setup

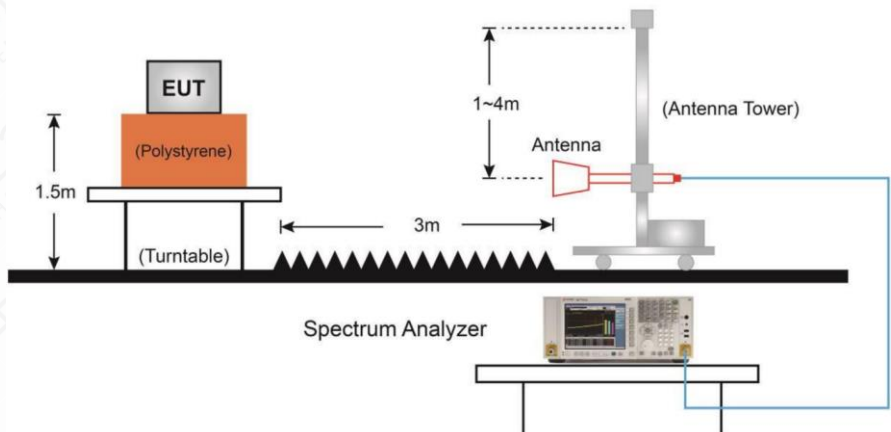

## 6.6.3 Measurement Results

Mode	Channel	Frequency Range	Conclusion
802.11ac-VHT80	155(5775MHz)	30 MHz ~1 GHz	P
		1 GHz ~ 8 GHz	P
		8 GHz ~ 18 GHz	P
		18 GHz ~ 26.5 GHz	P

The test data below 30MHz is more than 20dB lower than the limit value, so it is not provided in the report.

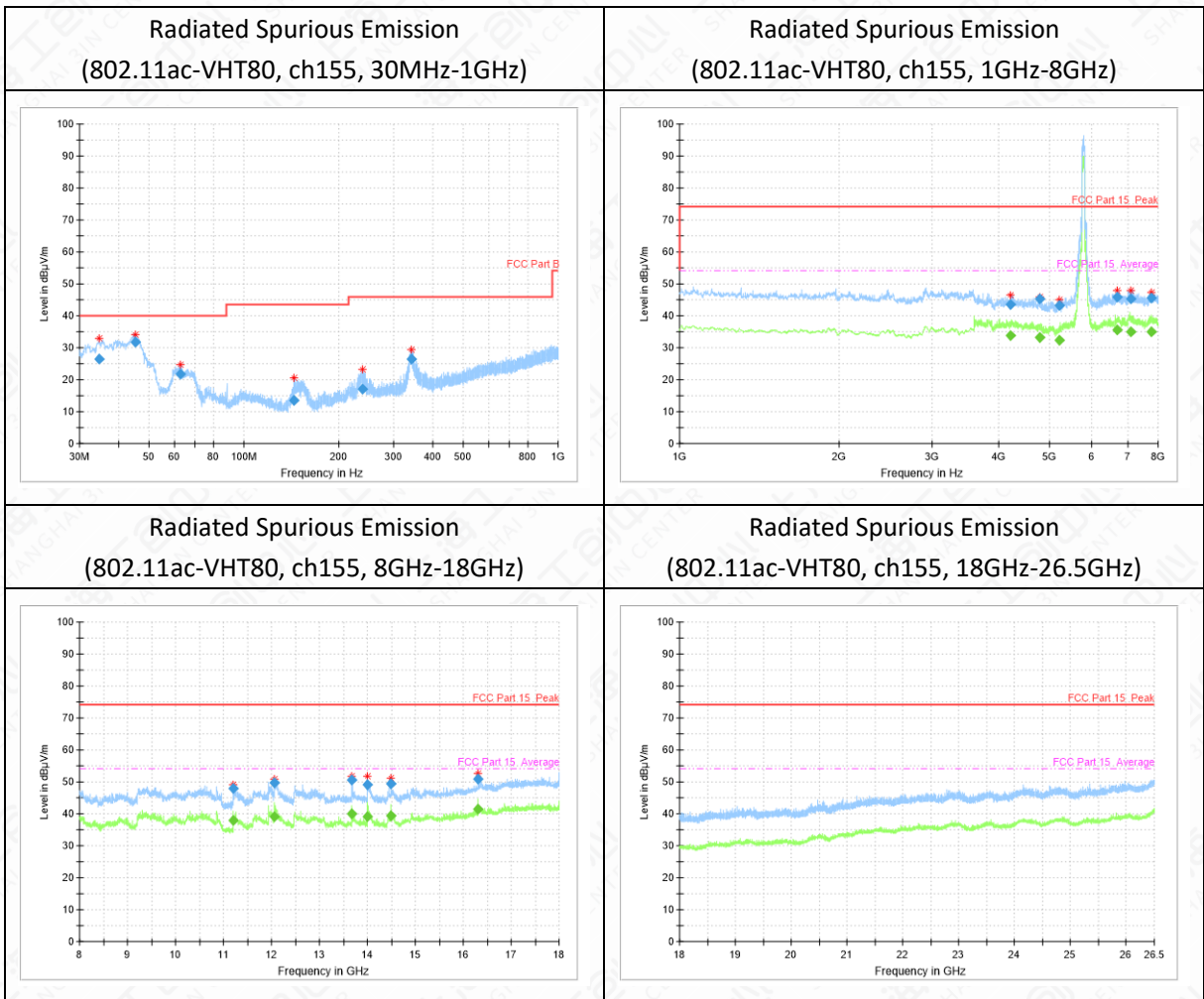

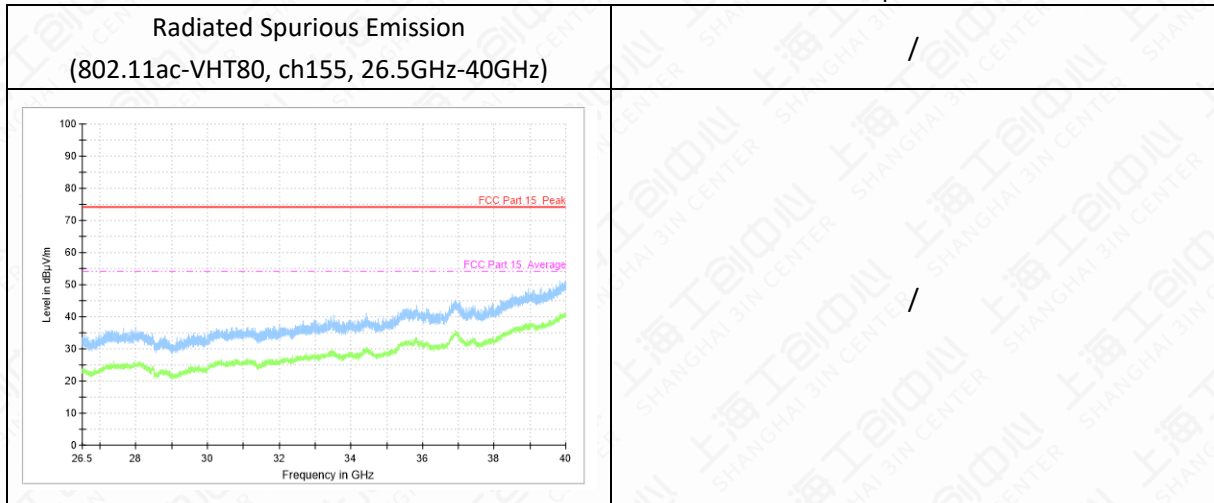

Note: Only data in worst mode is provided.

#### 802.11ac-VHT80 mode

##### Channel 155(30MHz ~ 1GHz )

Frequency(MHz)	Result(dBuV/m)	ARpl(dB)	PMea(dBuV/m)	Polarity
34.6	26.45	-14.1	40.55	V
45.3	31.63	-12.3	43.93	V
62.9	21.62	-13.3	34.92	V
144.4	13.45	-17.1	30.55	H
238.6	17.19	-12.5	29.69	H
340.3	26.45	-9.5	35.95	H

##### Channel 155 (1GHz-8GHz )

Frequency(MHz)	Result(dBuV/m)	ARpl(dB)	PMea(dBuV/m)	Polarity
4205.0	43.63	1.1	42.53	V
4778.0	45.3	1.5	43.8	H
5210.2	43.32	2.5	40.82	V
6688.8	45.79	4	41.79	H
7091.4	45.33	4.3	41.03	H
7758.4	45.49	4	41.49	V

##### Channel 155 (8GHz-18GHz)

Frequency(MHz)	Result(dBuV/m)	ARpl(dB)	PMea(dBuV/m)	Polarity
11201.6	47.88	7.9	39.98	V
12063.0	49.82	10.2	39.62	V
13677.0	50.62	11.6	39.02	V
14001.2	49.14	12.4	36.74	V
14485.8	49.39	12.5	36.89	V
16303.0	50.92	16.1	34.82	V

## 6.7 Band Edges Compliance

### 6.7.1 Measurement Limit

- (1) For transmitters operating in the 5.15-5.25 GHz band: All emissions outside of the 5.15-5.35 GHz band shall not exceed an e.i.r.p. of  $-27$  dBm/MHz.
- (2) For transmitters operating in the 5.25-5.35 GHz band: All emissions outside of the 5.15-5.35 GHz band shall not exceed an e.i.r.p. of  $-27$  dBm/MHz.
- (3) For transmitters operating in the 5.47-5.725 GHz band: All emissions outside of the 5.47-5.725 GHz band shall not exceed an e.i.r.p. of  $-27$  dBm/MHz.
- (4) All emissions shall be limited to a level of  $-27$  dBm/MHz at 75 MHz or more above or below the band edge increasing linearly to 10 dBm/MHz at 25 MHz above or below the band edge, and from 25 MHz above or below the band edge increasing linearly to a level of 15.6 dBm/MHz at 5 MHz above or below the band edge, and from 5 MHz above or below the band edge increasing linearly to a level of 27 dBm/MHz at the band edge.
- (5) In addition, radiated emissions which fall in the restricted bands, as defined in § 15.205(a), must also comply with the radiated emission limits specified in § 15.209(a) (see § 15.205(c)).

Frequency (MHz)	Field strength (microvolts/meter)	Measurement distance (meters)
0.009-0.490	2400/F(kHz)	300
0.490-1.705	24000/F(kHz)	30
1.705-30.0	30	30
30-88	100**	3
88-216	150**	3
216-960	200**	3
Above 960	500	3

MHz	MHz	MHz	GHz
0.090-0.110	16.42-16.423	399.9-410	4.5-5.15
0.495-0.505	16.69475-16.69525	608-614	5.35-5.46
2.1735-2.1905	16.80425-16.80475	960-1240	7.25-7.75
4.125-4.128	25.5-25.67	1300-1427	8.025-8.5
4.17725-4.17775	37.5-38.25	1435-1626.5	9.0-9.2
4.20725-4.20775	73-74.6	1645.5-1646.5	9.3-9.5
6.215-6.218	74.8-75.2	1660-1710	10.6-12.7
6.26775-6.26825	108-121.94	1718.8-1722.2	13.25-13.4
6.31175-6.31225	123-138	2200-2300	14.47-14.5
8.291-8.294	149.9-150.05	2310-2390	15.35-16.2
8.362-8.366	156.52475-156.52525	2483.5-2500	17.7-21.4
8.37625-8.38675	156.7-156.9	2690-2900	22.01-23.12
8.41425-8.41475	162.0125-167.17	3260-3267	23.6-24.0
12.29-12.293	167.72-173.2	3332-3339	31.2-31.8
12.51975-12.52025	240-285	3345.8-3358	36.43-36.5
12.57675-12.57725	322-335.4	3600-4400	(2)
13.36-13.41			

Set the spectrum analyzer in the following

1. Sweep mode: SweepAnalyzer6db.
2. PEAK: RBW=1MHz / VBW=3MHz / Sweep=2.5ms, Sweep point;5001
3. AVERAGE: RBW=1MHz / VBW=10Hz / Sweep=2.5ms, Sweep point;5001

### 6.7.2 Measurement Result

Mode	Channel	Conclusion
802.11a	149	P
	165	P
802.11n	149	P
HT20	165	P

802.11n HT40	151 159	P P
802.11ac VHT20	149 165	P P
802.11ac VHT40	151 159	P P
802.11ac VHT80	155	P

Test graphs as below:

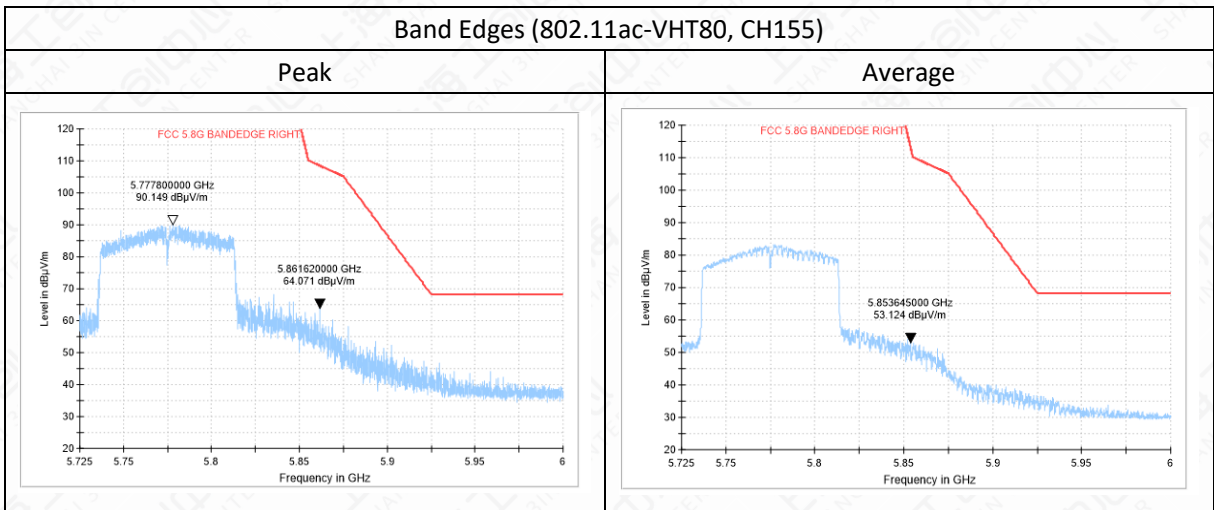

Note: Only data in worst mode is provided.

## 6.8 AC Powerline Conducted Emission

### 6.8.1 Method of Measurement: ANSI C63.10-2013-clause 6.2

1. The one EUT cable configuration and arrangement and mode of operation that produced the emission with the highest amplitude relative to the limit is selected for the final measurement, while applying the appropriate modulating signal to the EUT.
2. If the EUT is relocated from an exploratory test site to a final test site, the highest emissions shall be remaximized at the final test location before final ac power-line conducted emission measurements are performed.
3. The final test on all current-carrying conductors of all of the power cords to the equipment that comprises the EUT (but not the cords associated with other non-EUT equipment in the system) is then performed for the full frequency range for which the EUT is being tested for compliance without further variation of the EUT arrangement, cable positions, or EUT mode of operation.
4. If the EUT is comprised of equipment units that have their own separate ac power connections, e.g., floor-standing equipment with independent power cords for each shelf that are able to connect directly to the ac power network, each current-carrying conductor of one unit is measured while the other units are connected to a second (or more) LISN(s). All units shall be separately measured. If a power strip is provided by the manufacturer, to supply all of the units making up the EUT, only the conductors in the power cord of the power strip shall be measured.

If the EUT uses a detachable antenna, these measurements shall be made with a suitable dummy load connected to the antenna output terminals; otherwise, the tests shall be made with the antenna connected and, if adjustable, fully extended. When measuring the ac conducted emissions from a device that operates between 150 kHz and 30 MHz a non-detachable antenna may be replaced with a dummy load for the measurements within the fundamental emission band of the transmitter, but only for those measurements.<sup>36</sup> Record the six highest EUT emissions relative to the limit of each of the current-carrying conductors of the power cords of the equipment that comprises the EUT over the frequency range specified by the procuring or regulatory agency. Diagram or photograph the test setup that was used. See Clause 8 for full reporting requirements.



6.8.2 Test Setup

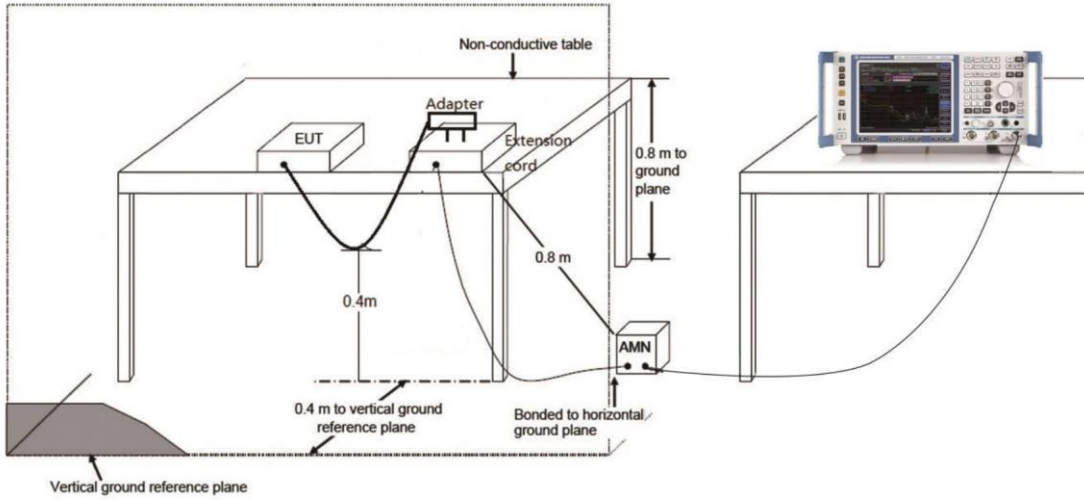

6.8.3 Test Condition

Voltage (V)	Frequency (Hz)
120	60

Measurement Result and limit  
(Quasi-peak-average Limit)

Frequency range (MHz)	Quasi-peak Limit (dB $\mu$ V)	Average Limit (dB $\mu$ V)	Conclusion
0.15 to 0.5	66 to 56	56 to 46	P
0.5 to 5	56	46	
5 to 30	60	50	

NOTE: The limit decreases linearly with the logarithm of the frequency in the range 0.15 MHz to 0.5 MHz.

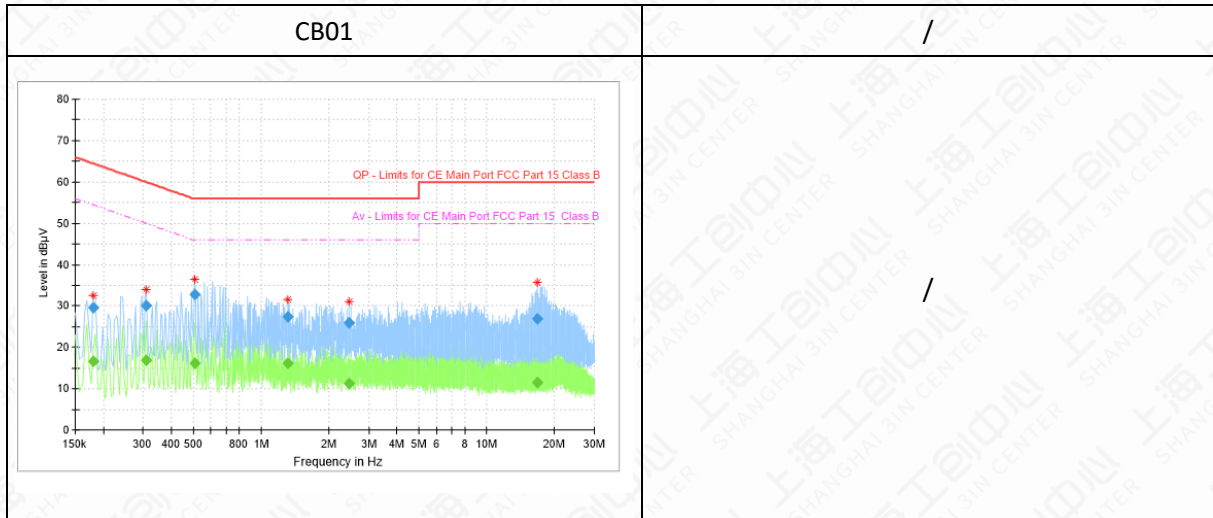

Frequency (MHz)	QuasiPeak (dBµV)	Average (dBµV)	Limit (dBµV)	Margin (dB)	Meas. Time (ms)	Bandwidth (kHz)	Line	Filter	Corr. (dB)
0.179850	---	16.72	54.49	37.78	15000.0	9.000	L1	ON	9.6
0.179850	29.68	---	64.49	34.82	15000.0	9.000	L1	ON	9.6
0.310444	---	16.80	49.96	33.16	15000.0	9.000	L1	ON	9.6
0.310444	30.07	---	59.96	29.89	15000.0	9.000	L1	ON	9.6
0.508200	---	16.04	46.00	29.96	15000.0	9.000	L1	ON	9.6
0.508200	32.68	---	56.00	23.32	15000.0	9.000	L1	ON	9.6
1.317881	---	16.15	46.00	29.85	15000.0	9.000	N	ON	9.7
1.317881	27.32	---	56.00	28.68	15000.0	9.000	N	ON	9.7
2.455913	---	11.16	46.00	34.84	15000.0	9.000	N	ON	9.7
2.455913	26.04	---	56.00	29.96	15000.0	9.000	N	ON	9.7
16.739138	---	11.50	50.00	38.50	15000.0	9.000	N	ON	10.1
16.739138	26.86	---	60.00	33.14	15000.0	9.000	N	ON	10.1

**Annex A: Revised History**

Version	Revised Content
V00	Initial
V01	Update the FCC Designation No.in section 2.1; Update the FCC ID and HVIN in section 4.1

Annex B: Accreditation Certificate



The certificate features a decorative orange and blue wavy border on the left side. At the top center, it displays the logos for ILAC-MRA and A2LA. Below the logos, the text reads "Accredited Laboratory" in a large, bold, blue font. Underneath, it states "A2LA has accredited" in a smaller font, followed by "INDUSTRIAL INTERNET INNOVATION CENTER (SHANGHAI) CO., LTD." in a large, bold, blue font. Below the company name, it says "Shanghai, People's Republic of China" in a smaller font. Further down, it specifies "for technical competence in the field of Electrical Testing" in a bold, blue font. A paragraph of text follows, stating: "This laboratory is accredited in accordance with the recognized International Standard ISO/IEC 17025:2017 General requirements for the competence of testing and calibration laboratories. This accreditation demonstrates technical competence for a defined scope and the operation of a laboratory quality management system (refer to joint ISO-ILAC-IAF Communiqué dated April 2017)." To the left of this paragraph is a gold-colored circular seal with the text "CORPORATE SEAL 1978" and "A2LA". To the right of the seal is a blue ink signature. Below the signature, it says "Presented this 12<sup>th</sup> day of April 2021." and "Vice President, Accreditation Services For the Accreditation Council Certificate Number 3682.01 Valid to February 28, 2023". At the bottom of the certificate, it reads "For the tests to which this accreditation applies, please refer to the laboratory's Electrical Scope of Accreditation."

END OF REPORT