

**Industrial Internet Innovation Center (Shanghai) Co.,Ltd.**

**EMC TEST REPORT**

<b>PRODUCT</b>	Wireless data POS System
<b>BRAND</b>	SUNMI
<b>MODEL</b>	T5820
<b>APPLICANT</b>	Shanghai Sunmi Technology Co.,Ltd.
<b>FCC ID</b>	2AH25T5820
<b>IC</b>	22621-T5820
<b>ISSUE DATE</b>	February 10, 2023
<b>STANDARD(S)</b>	FCC Part 15, Subpart B, ANSI C63.4-2014, ICES-003 Issue 7.

Prepared by: Peng Xin

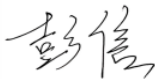

Reviewed by: Qin Yabin



Approved by: Zhang Min



**CAUTION:**

*This report shall not be reproduced except in full without the written permission of the test laboratory and shall not be quoted out of context.*

## CONTENTS

<b>1 SUMMARY OF TEST REPORT</b> .....	<b>3</b>
1.1 TEST STANDARD (S) .....	3
1.2 SUMMARY OF TEST RESULTS .....	3
<b>2 GENERAL INFORMATION OF THE LABORATORY</b> .....	<b>4</b>
2.1 TESTING LABORATORY .....	4
2.2 LABORATORY ENVIRONMENTAL REQUIREMENTS .....	4
2.3 PROJECT INFORMATION .....	4
<b>3 GENERAL INFORMATION OF THE CUSTOMER</b> .....	<b>5</b>
3.1 APPLICANT .....	5
3.2 MANUFACTURER .....	5
3.3 FACTORY .....	5
<b>4 GENERAL INFORMATION OF THE PRODUCT</b> .....	<b>6</b>
4.1 PRODUCT DESCRIPTION FOR EQUIPMENT UNDER TEST (EUT) .....	6
4.2 DESCRIPTION FOR AUXILIARY EQUIPMENT (AE) .....	6
<b>5 TEST CONFIGURATION INFORMATION</b> .....	<b>8</b>
5.1 LABORATORY ENVIRONMENTAL CONDITIONS .....	8
5.2 DECISION OF FINAL TEST MODE .....	9
5.3 EUT SYSTEM OPERATION .....	10
5.4 EUT CONNECTION DIAGRAM OF TEST SYSTEM .....	10
5.5 TEST EQUIPMENT UTILIZED .....	11
5.6 MEASUREMENT UNCERTAINTY .....	11
<b>6 TEST RESULTS</b> .....	<b>12</b>
6.1 RADIATED EMISSION .....	12
6.2 CONDUCTED EMISSION .....	14
<b>ANNEX A: MEASUREMENT DATA</b> .....	<b>16</b>
<b>ANNEX B: REVISED HISTORY</b> .....	<b>20</b>
<b>ANNEX C: ACCREDITATION CERTIFICATE</b> .....	<b>21</b>

## 1 Summary of Test Report

### 1.1 Test Standard (s)

No.	Test Standard(s)	Title	Version
1	FCC Part 15, Subpart B	Radio frequency devices	2021/10/1
2	ANSI C63.4	Method of Measurement of Radio-Noise Emissions from Low-Voltage Electrical and Electronic Equipment in the Range of 9 kHz to 40 GHz	2014
3	ICES-003	Information Technology Equipment (Including Digital Apparatus)-Limits and Methods of Measurement	Issue 7

NOTE:

- According to customer requirements, test and report using the latest version of the standard.

### 1.2 Summary of Test Results

No.	Item(s)	Standard(s)	Verdicts for Single Item	Detailed Results
1	Radiated Emission	15.109(a)	Pass	See section 6.1
2	AC Conducted Emission	15.107(a)	Pass	See section 6.2

NOTE:

The T5820, manufactured by Shanghai Sunmi Technology Co.,Ltd. is a variant product for testing. Industrial Internet Innovation Center (Shanghai) Co., Ltd. only performed test cases which identified with Pass/Fail/Inc result in section 1.3.

Industrial Internet Innovation Center (Shanghai) Co., Ltd. has verified that the compliance of the tested device specified in section 4 of this test report is successfully evaluated according to the procedure and test methods as defined in type certification requirement listed in section 1 of this test report.

## 2 General Information of The Laboratory

### 2.1 Testing Laboratory

Lab Name	Industrial Internet Innovation Center (Shanghai) Co.,Ltd.
Address	Building 4, No. 766, Jingang Road, Pudong, Shanghai, China
Telephone	021-68866880
FCC Registration No.	958356
FCC Designation No.	CN1177
IC designation No.	CN0067

### 2.2 Laboratory Environmental Requirements

Temperature	15°C~35°C
Relative Humidity	25%RH~75%RH
Atmospheric Pressure	86kPa~106kPa
Supply Voltage	120V/60Hz

### 2.3 Project Information

Project Manager	Gao Hongning
Test Date	November 11, 2022 to January 19, 2023

### 3 General Information of The Customer

#### 3.1 Applicant

Company	Shanghai Sunmi Technology Co.,Ltd.
Address	Room 505, No.388, Song Hu Road, Yang Pu District, Shanghai, China
Telephone	13510126210

#### 3.2 Manufacturer

Company	Shanghai Sunmi Technology Co.,Ltd.
Address	Room 505, No.388, Song Hu Road, Yang Pu District, Shanghai, China
Telephone	13510126210

#### 3.3 Factory

Company	N/A
Address	N/A

## 4 General Information of The Product

### 4.1 Product Description for Equipment under Test (EUT)

Product	Wireless data POS System
Model	T5820
Date of Receipt	October 20, 2022
EUT ID*	S02aa
SN/IMEI	860450060011182'860450060011190
Supported Radio Technology and Bands	GSM850/GSM900/GSM1800/GSM1900 WCDMA Band I/II/ IV/V/VIII LTE Band 1/2/3/4/5/7/12/17/28/38/41 BT5.1 WLAN 802.11b,g,n WLAN 802.11a,n,ac GPS GLONASS BDS
Hardware Version	V01
Software Version	XQT530_V004_20220923
HVIN	T5820
NOTE1: EUT ID is the internal identification code of the laboratory.	
NOTE2: Photographs of EUT are shown in ANNEX A of this test report.	

### 4.2 Description for Auxiliary Equipment (AE)

AE ID*	Description	Model	SN/Remark
CA01	Adapter	TPA-46B050100UU	N/A
UA01	USB Cable	N/A	N/A
AE1	Notebook PC	DELL Latitude E6510	N/A
AE2	Desktop PC	OptiPlex 790 DT	X8RP1 A01 APCC
AE3	LAN Cable	N/A	N/A
AE4	VGA Cable	N/A	N/A
AE5	RS232 Cable	N/A	N/A
AE6	Keyboard	KB212-B	CN-0Y88XT-65890-12I-005Q-A00
AE7	Mouse	MS111-P	CN-011D3V-71581-19J-1A64

AE8	Monitor	Dell E1709Wc	N/A
AE9	Micro SD card	Kingston SDC4/4GB 77	N/A

NOTE: \*AE ID is the internal identification code of the laboratory.

## 5 Test Configuration Information

### 5.1 Laboratory Environmental Conditions

#### 5.1.1 Permanent Facilities

Semi-anechoic chamber SAC3-1 (9 m*8m*6.2m) & SAC3-2 (9.8m*6.7m*6.7m)	
Shielding effectiveness	0.014MHz ~1MHz, >60dB; 1MHz~1000MHz, >90dB.
Electrical insulation	> 2MΩ
Ground system resistance	< 4Ω
Normalised site attenuation (NSA)	< ± 4 dB, 3m distance, from 30 to 1000 MHz
Site voltage standing-wave ratio (SVSWR)	Between 0 and 6 dB, from 1GHz to 18GHz
Uniformity of field strength	Between 0 and 6 dB, from 80 to 6000 MHz

Shielded room	
Shielding effectiveness	0.014MHz~1MHz, >60dB; 1MHz~1000MHz, >90dB.
Electrical insulation	> 2 MΩ
Ground system resistance	< 4Ω



## 5.2 Decision of final test mode

The EUT was tested in conjunction with the accessories in Section 4.2. We tested all of the following test modes and selected the worst mode from the test results and recorded them in the report.

The test configuration modes are as the following:

Test Item	Test setup and operating modes
Radiated emission	30MHz-18GHz frequency range: Mode 1: LTE2 receiver mode + Camera+ CA01+ UA01 Mode 2: Data Link mode + UA01 Mode 3: GPS mode + CA01+ UA01 Mode 4: GLONASS mode + CA01+ UA01 Mode 5: BDS mode + CA01+ UA01 Mode 6: Print mode + CA01+ UA01
AC Conducted emission	Mode 1: LTE2 receiver mode + Camera+ CA01+ UA01 Mode 2: Data Link mode + UA01 Mode 3: GPS mode + CA01+ UA01 Mode 4: GLONASS mode + CA01+ UA01 Mode 5: BDS mode + CA01+ UA01 Mode 6: Print mode + CA01+ UA01
<p><b>Note:</b></p> <ol style="list-style-type: none"> <li>All test modes are performed, only the worst cases test data are recorded in this report.</li> <li>After laboratory verification, LTE band 2 is the worst mode among all receiving modes of 2G/3G/4G and is recorded in the report.</li> <li>The worst case of radiated emission for 30MHz-1GHz is Mode 2 and for 1GHz -18GHz is Mode 2.</li> <li>The worst case for conducted emission is mode 6.</li> </ol>	

### 5.3 EUT System Operation

1. Connect the EUT with AE.
2. Setup the EUT according to the standard.
3. Start testing and monitoring the function.
4. Data Link with PC means data application transferred mode between EUT and PC.
5. EUT and GNSS simulator (SMBV100A) connection is established.
6. The EUT remains in print mode.

### 5.4 EUT Connection Diagram of Test System

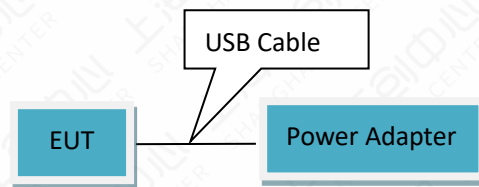

<Figure 5.4-1> Mode 1,3~6

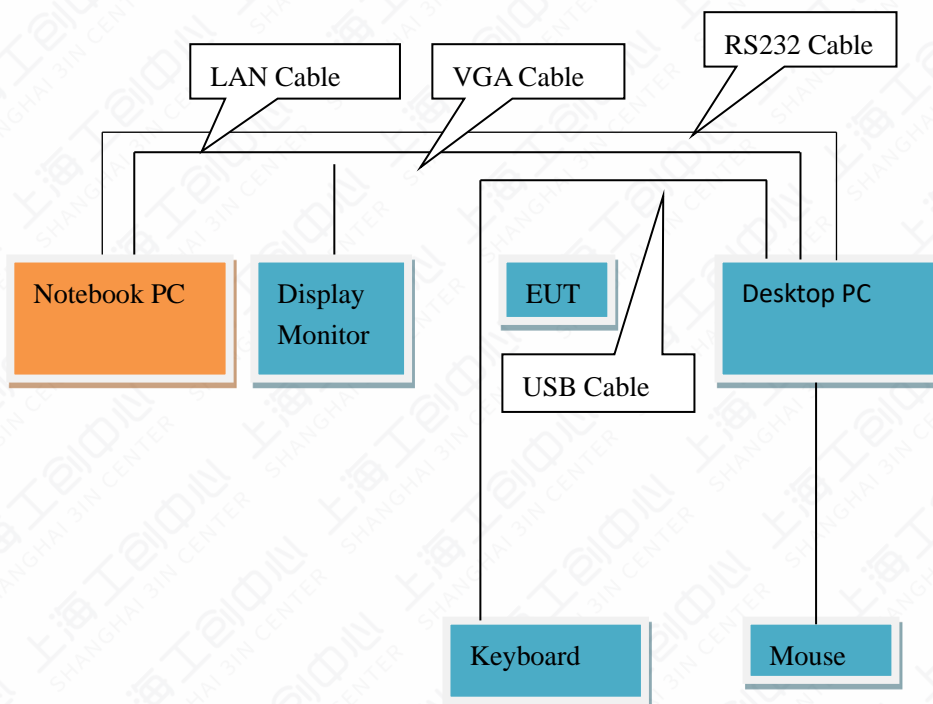

<Figure 5.4-2> Mode 2

### 5.5 Test Equipment Utilized

No.	Name	Model	S/N	Manufacturer	Cal. Date	Cal. Interval
1	Test Receiver	ESCI	101235	R&S	2022-02-23	1 year
2	Test Receiver	ESU40	100307	R&S	2022-02-23	1 year
3	Trilog Antenna	VULB9163	VULB9163-515	Schwarzbeck	2022-03-11	1 year
4	Double Ridged Guide Antenna	ETS-3117	00135890	ETS	2022-03-09	2 years
5	2-Line V-Network	ENV216	101380	R&S	2022-02-21	1 year
6	EMI Test Software	EMC32 V9.15	N/A	R&S	N/A	N/A
7	Universal Radio Communication Tester	CMW500	104178	R&S	2022-10-17	1 year
8	GNSS simulator	SMBV100A	257904	R&S	2022-02-21	1 year
9	Universal Radio Communication Tester	CMU200	123102	R&S	2022-10-17	1 year

### 5.6 Measurement Uncertainty

Item (s)	Uncertainty
Radiated Emission 30MHz-1000MHz	4.94 dB
Radiated Emission 1000MHz-18000MHz	5.02 dB
Conducted Emission	3.56 dB

Note: This uncertainty represents an expanded uncertainty expressed at approximately the 95% confidence level using a coverage factor of  $k=2$ .

## 6 Test Results

### 6.1 Radiated Emission

#### 6.1.1 Method of Measurement

a. For 30MHz -1000MHz, the EUT was placed on the top of a rotating 0.8m table above the ground at a semi-anechoic chamber. The distance between the EUT and the received antenna was 3 meters. The table was rotated 360 degree and the received antenna mounted on a variable-height antenna tower was varied from 1m to 4m to find the maximum value of the field strength. Both horizontal and vertical polarizations of the antenna were set during the measurement.

b. For 1000MHz -18000MHz, the EUT was placed on the top of a 0.8m table above the ground at a 3m fully anechoic chamber. The maximal emission value was acquired by adjusting the antenna height, The table was rotated 360 degree to determine the maximum value of the field strength. Both horizontal and vertical polarizations of the antenna were set during the measurement

#### 6.1.2 EUT Connection Diagram of Test System

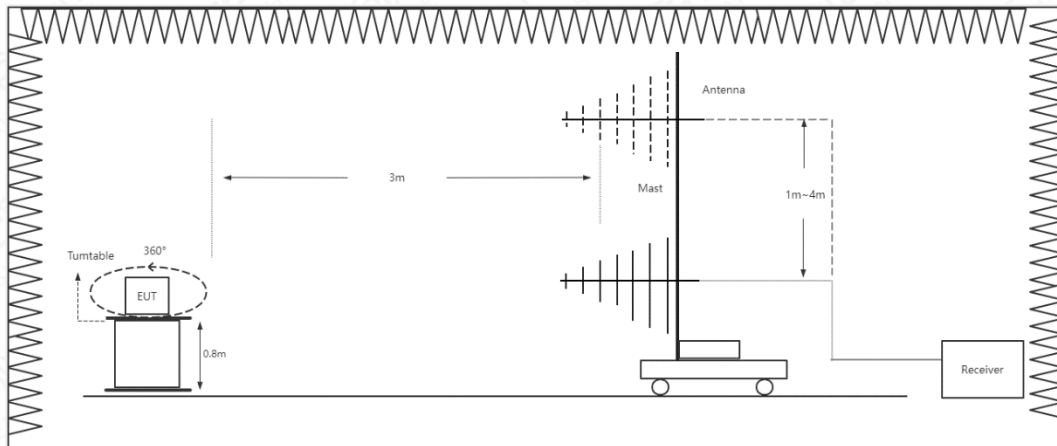

Figure 6.1.2-1 RE 30MHz-1GHz Connection Diagram

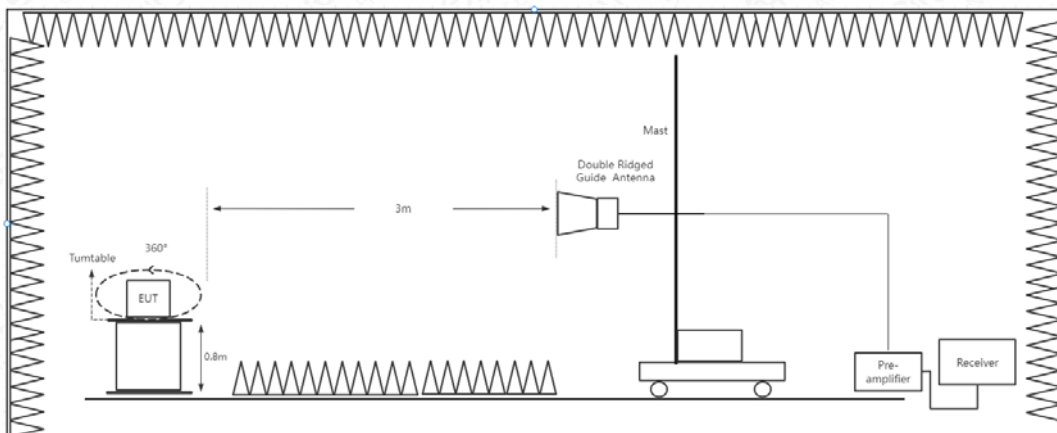

Figure 6.1.2-2 RE Above 1GHz Connection Diagram

## 6.1.3 Test Condition

Frequency Range (MHz)	RBW/VBW	Sweep Time (s)
30-1000	120kHz/300kHz	AUTO
1000-18000	1MHz/3MHz	AUTO

## 6.1.4 Limit/Criterion

Frequency Range (MHz)	Quasi-Peak (dB $\mu$ V/m)	Peak (dB $\mu$ V/m)	Average (dB $\mu$ V/m)
30-88	40	N/A	N/A
88-216	43.5	N/A	N/A
216-960	46	N/A	N/A
Above 960	54	N/A	N/A
Above 1000	N/A	74	54

## 6.1.5 Test environmental conditions

Temperature	23.2°C
Relative Humidity	54.3%RH
Atmospheric Pressure	101.6kPa

## 6.1.6 Test Results

Mode	Frequency (MHz)	Test Results	Verdicts
Mode 2: Data Link mode+ UA01	30-1000	See Annex A.1-1	Pass
Mode 2: Data Link mode+ UA01	1000-18000	See Annex A.1-2 & A.1-3	Pass

NOTE Abbreviations used in this clause: Pass—P; Fail—F; Not applicable—N/A

## 6.2 Conducted Emission

### 6.2.1 Method of Measurement

The EUT was placed on a 0.8m height table with EUT being connected to the power mains through a line impedance stabilization network (LISN). Both lines of the power mains connected to the EUT were checked for maximum conducted interference. The frequency range from 150 kHz to 30 MHz was searched.

### 6.2.2 EUT Connection Diagram of Test System

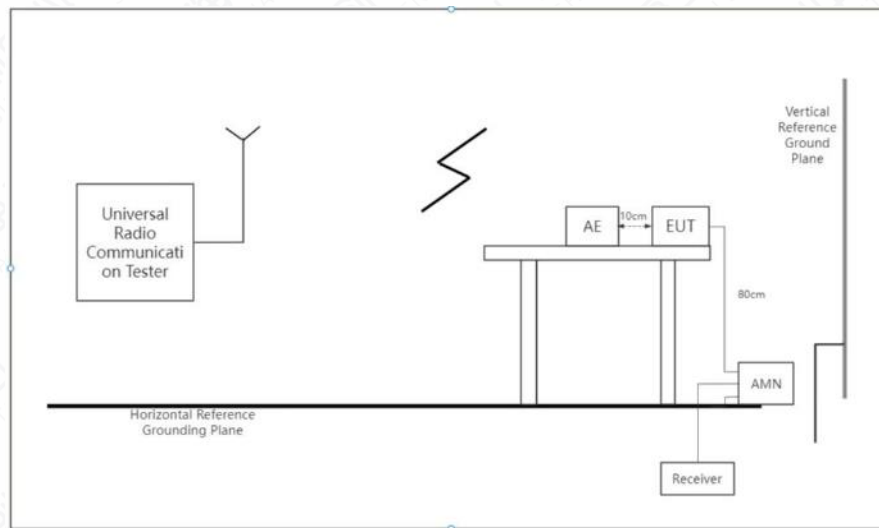

Figure 6.2.2-1 CE Connection Diagram

### 6.2.3 Test Condition

#### Test Condition in Charging Mode

Voltage (V)	Frequency (Hz)	RBW	Sweep Time (s)
120	60	9 kHz	AUTO

### 6.2.4 Limit

Frequency Range (MHz)	Conducted Limit (dB $\mu$ V)	
	Quasi-peak	Average
0.15-0.5	66 to 56*	56 to 46*
0.5-5	56	46
5-30	60	50

\*Decreases with the logarithm of the frequency

**6.2.5 Testing environmental conditions**

Temperature	24.5°C
Relative Humidity	54.1%RH
Atmospheric Pressure	102.1 kPa

**6.2.6 Test Results**

Mode	Frequency (MHz)	Test Results	Verdicts
Mode 6: Print mode+ CA01+UA01	0.15-30	See Annex A.2-1	Pass
NOTE Abbreviations used in this clause: Pass—P; Fail—F; Not applicable—N/A			

## Annex A: Measurement Data

### A.1 Radiated Emission

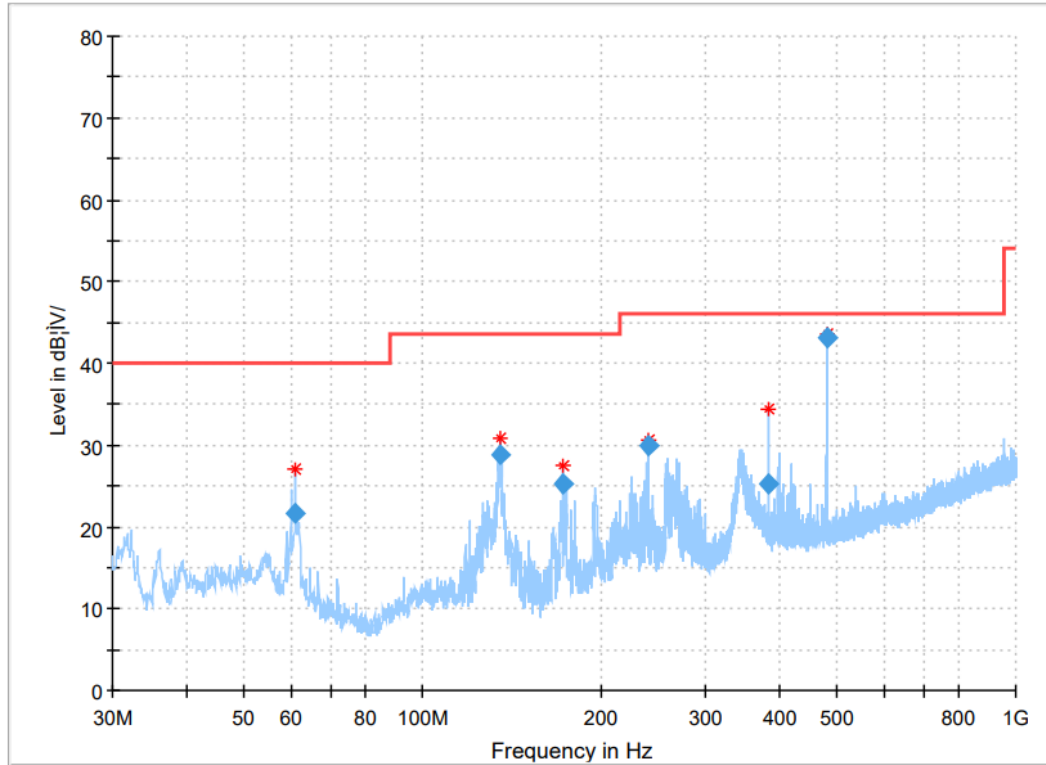

Figure A.1-1 Mode 2 (30M-1GHz)

Frequency (MHz)	QuasiPeak (dBµV/m)	Limit (dBµV/m)	Margin (dB)	Height (cm)	Pol	Azimuth (deg)	Corr. (dB)
61.102600	21.72	40.00	18.28	100.0	V	48.0	-13.1
135.292280	28.84	43.50	14.66	100.0	V	48.0	-16.3
172.472560	25.14	43.50	18.36	100.0	V	240.0	-15.2
240.001000	29.87	46.00	16.13	100.0	V	127.0	-11.2
383.928320	25.17	46.00	20.83	100.0	H	117.0	-7.6
480.004000	43.24	46.00	2.76	100.0	H	352.0	-5.7

Note: Horizontal and vertical polarity is all have been tested, the result of them is synthesized in the above data diagram.



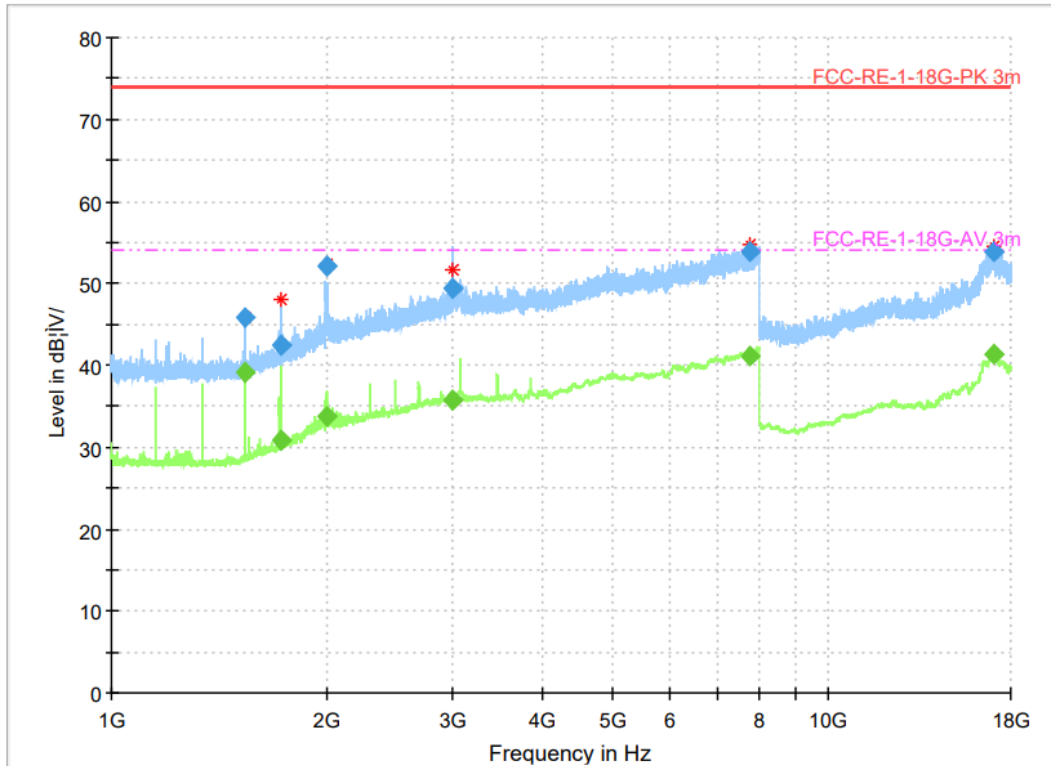

Figure A.1-2 Mode 2 (1GHz-18GHz)-H

Frequency (MHz)	MaxPeak (dBμV/m)	Average (dBμV/m)	Limit (dBμV/m)	Margin (dB)	Meas. Time (ms)	Bandwidth (kHz)	Height (cm)	Pol	Azimuth (deg)	Corr. (dB)
1535.9875	45.88	---	74.00	28.12	500.0	1000.0	100.0	H	141.0	2.7
1535.9875	---	39.07	54.00	14.93	500.0	1000.0	100.0	H	141.0	2.7
1729.1687	---	30.84	54.00	23.16	500.0	1000.0	215.0	H	282.0	4.4
1729.1687	42.43	---	74.00	31.57	500.0	1000.0	215.0	H	282.0	4.4
1992.1162	---	33.79	54.00	20.21	500.0	1000.0	100.0	H	141.0	6.7
1992.1162	52.10	---	74.00	21.90	500.0	1000.0	100.0	H	141.0	6.7
2995.3069	---	35.77	54.00	18.23	500.0	1000.0	103.0	H	170.0	11.6
2995.3069	49.44	---	74.00	24.56	500.0	1000.0	103.0	H	170.0	11.6
7789.1312	---	41.18	54.00	12.82	500.0	1000.0	185.0	H	254.0	20.7
7789.1312	53.75	---	74.00	20.25	500.0	1000.0	185.0	H	254.0	20.7
17029.303	53.93	---	74.00	20.07	500.0	1000.0	115.0	H	3.0	22.6
17029.303	---	41.28	54.00	12.72	500.0	1000.0	115.0	H	3.0	22.6

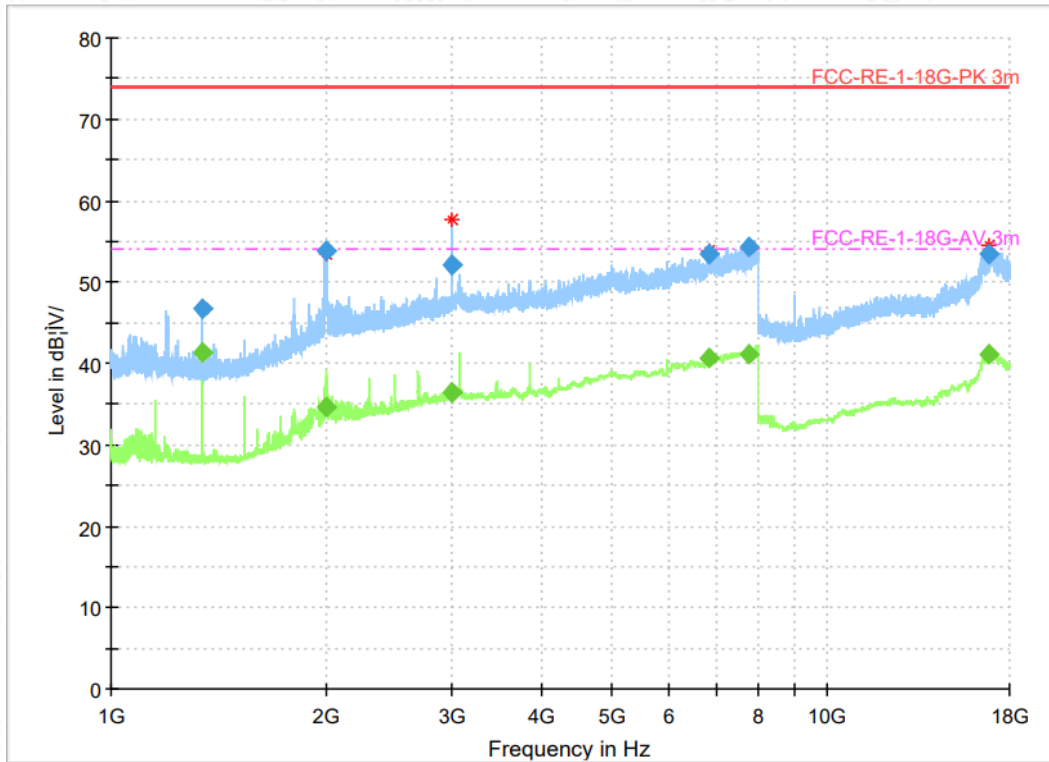

Figure A.1-3 Mode 2 (1GHz-18GHz)-V

Frequency (MHz)	MaxPeak (dBµV/m)	Average (dBµV/m)	Limit (dBµV/m)	Margin (dB)	Meas. Time (ms)	Bandwidth (kHz)	Height (cm)	Pol	Azimuth (deg)	Corr. (dB)
1343.7662	46.74	---	74.00	27.26	500.0	1000.0	102.0	V	305.0	2.1
1343.7662	---	41.27	54.00	12.73	500.0	1000.0	102.0	V	305.0	2.1
1997.9062	53.85	---	74.00	20.15	500.0	1000.0	100.0	V	49.0	6.7
1997.9062	---	34.71	54.00	19.30	500.0	1000.0	100.0	V	49.0	6.7
2998.2737	---	36.46	54.00	17.54	500.0	1000.0	100.0	V	77.0	11.7
2998.2737	51.98	---	74.00	22.02	500.0	1000.0	100.0	V	77.0	11.7
6849.4012	---	40.63	54.00	13.37	500.0	1000.0	115.0	V	326.0	19.3
6849.4012	53.46	---	74.00	20.54	500.0	1000.0	115.0	V	326.0	19.3
7801.6350	---	41.20	54.00	12.80	500.0	1000.0	115.0	V	194.0	20.8
7801.6350	54.23	---	74.00	19.77	500.0	1000.0	115.0	V	194.0	20.8
16865.968	---	41.07	54.00	12.93	500.0	1000.0	102.0	V	236.0	22.4
16865.968	53.51	---	74.00	20.49	500.0	1000.0	102.0	V	236.0	22.4

## A.2 Conducted Emission

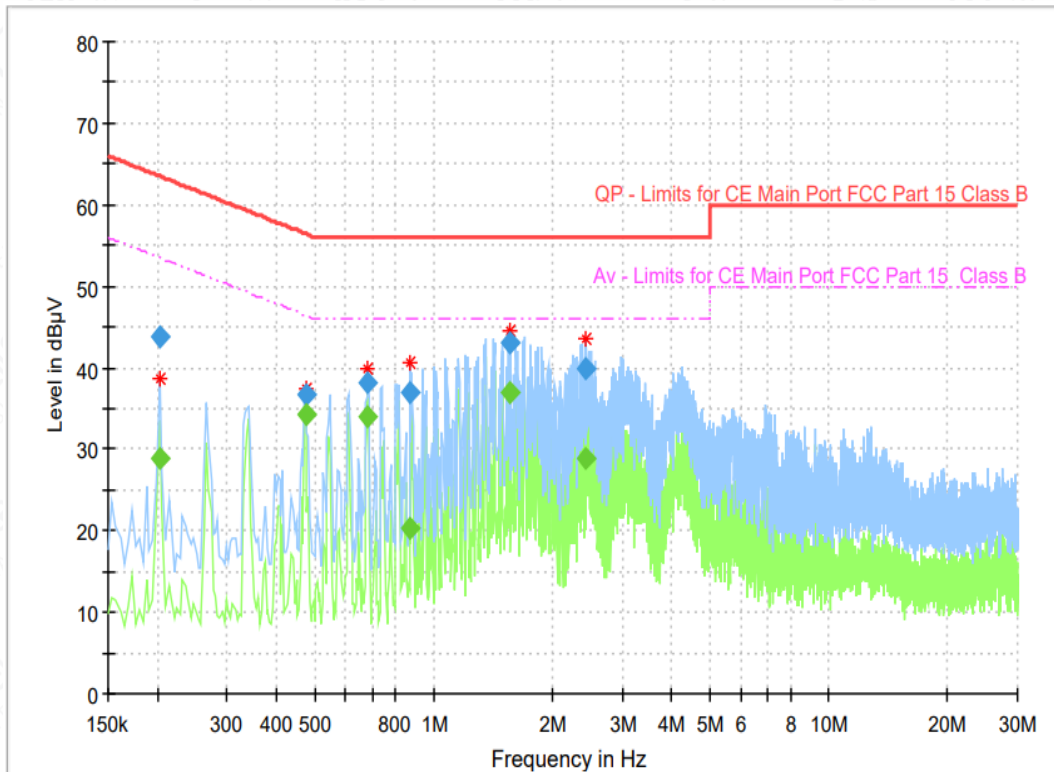

Figure A.2-1 Mode 6(150kHz-30MHz)

Frequency (MHz)	QuasiPeak (dBµV)	Average (dBµV)	Limit (dBµV)	Margin (dB)	Meas. Time (ms)	Bandwidth (kHz)	Line	Filter	Corr. (dB)
0.202238	---	28.85	53.52	24.67	15000	9.000	L1	ON	9.6
0.202238	43.81	---	63.52	19.70	15000	9.000	L1	ON	9.6
0.474619	---	34.31	46.43	12.13	15000	9.000	N	ON	9.4
0.474619	36.61	---	56.43	19.82	15000	9.000	N	ON	9.4
0.679838	---	33.95	46.00	12.05	15000	9.000	N	ON	9.6
0.679838	38.10	---	56.00	17.90	15000	9.000	N	ON	9.6
0.870131	---	20.27	46.00	25.73	15000	9.000	N	ON	9.6
0.870131	36.89	---	56.00	19.11	15000	9.000	N	ON	9.6
1.564144	---	36.89	46.00	9.11	15000	9.000	N	ON	9.7
1.564144	43.11	---	56.00	12.89	15000	9.000	N	ON	9.7
2.422331	---	28.80	46.00	17.20	15000	9.000	N	ON	9.7
2.422331	40.00	---	56.00	16.00	15000	9.000	N	ON	9.7

Note: L1 and N line is all have been tested, the result of them is synthesized in the above data diagram.

**Annex B: Revised History**

<b>Version</b>	<b>Revised Content</b>
V00	Initial

Annex C: Accreditation Certificate



**Accredited Laboratory**

A2LA has accredited

**INDUSTRIAL INTERNET INNOVATION CENTER  
(SHANGHAI) CO., LTD.**  
*Shanghai, People's Republic of China*

for technical competence in the field of  
**Electrical Testing**

This laboratory is accredited in accordance with the recognized International Standard ISO/IEC 17025:2017 General requirements for the competence of testing and calibration laboratories. This accreditation demonstrates technical competence for a defined scope and the operation of a laboratory quality management system (refer to joint ISO-ILAC-IAF Communiqué dated April 2017).



Presented this 12<sup>th</sup> day of April 2021.



Vice President, Accreditation Services  
For the Accreditation Council  
Certificate Number 3682.01  
Valid to February 28, 2023

*For the tests to which this accreditation applies, please refer to the laboratory's Electrical Scope of Accreditation.*