



TEST REPORT

No. I18D00147-EMC01

For

Client : Shanghai Sunmi Technology Co.,Ltd.

Production: POS System

Model Name : “T3521” “T3522” “T3523”

Hardware Version: V1.02

Software Version: 1.1.16 / 1.1.17

FCC ID: 2AH25T2LITE

Issued date: 2018-09-27

Note:

The test results in this test report relate only to the devices specified in this report. This report shall not be reproduced except in full without the written approval of ECIT Shanghai.

Test Laboratory:

ECIT Shanghai, East China Institute of Telecommunications

Add: 7F, G Area, No.668, Beijing East Road, Huangpu District, Shanghai, P. R. China

Tel: (+86)-021-63843300, E-Mail: welcome@ecit.org.cn

Revision Version

Report Number	Revision	Date	Memo
I18D00147-EMC01	00	2018-09-27	Initial creation of test report

CONTENTS

1. TEST LABORATORY	5
1.1. TESTING LOCATION	5
1.2. TESTING ENVIRONMENT	5
1.3. PROJECT DATA.....	5
1.4. SIGNATURE.....	5
1.5. CLIENT INFORMATION	6
1.6. APPLICANT INFORMATION.....	6
1.7. MANUFACTURER INFORMATION.....	6
2. EQUIPMENT UNDER TEST (EUT) AND ANCILLARY EQUIPMENT (AE)	7
2.1. ABOUT EUT.....	7
3.2. INTERNAL IDENTIFICATION OF EUT USED DURING THE TEST	7
3.3. INTERNAL IDENTIFICATION OF AE USED DURING THE TEST	7
4. REFERENCE DOCUMENTS.....	8
4.1 REFERENCE DOCUMENTS FOR TESTING.....	8
5. TEST RESULTS.....	9
5.1 SUMMARY OF TEST RESULTS	9
5.2 STATEMENTS.....	9
6. TEST EQUIPMENT UTILIZED	10
6.1 RADIATED EMISSION EQUIPMENT LIST	10
6.1 AC CONDUCTED EMISSION EQUIPMENT LIST	10
7. SYSTEM CONFIGURATION DURING TEST.....	11
7.1 TEST MODE.....	11
7.2 CONNECTION DIAGRAM OF TEST SYSTEM.....	12
8. MEASUREMENT RESULTS.....	13
8.1 RADIATED EMISSION 30MHZ-18GHZ.....	13

8.2 CONDUCTED EMISSION..... 23

1. Test Laboratory

1.1. Testing Location

Company Name: ECIT Shanghai, East China Institute of Telecommunications
Address: 7F, G Area, No. 668, Beijing East Road, Huangpu District, Shanghai,
P. R. China
Postal Code: 200001
Telephone: 86-21-63843300
Fax: 86-21-63843301
FCC registration No: 489729

1.2. Testing Environment

Normal Temperature: 15-35°C
Relative Humidity: 30-60%RH

1.3. Project data

Project Leader: Zhou Yan
Testing Start Date: 08-28, 2018
Testing End Date: 09-27, 2018

1.4. Signature



Qin Yabin
(Prepared this test report)



You Jinjun
(Reviewed this test report)

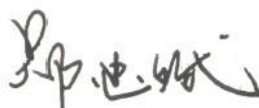

Zheng Zhongbin
(Approved this test report)

1.5. Client Information**1.6. Applicant Information**

Company Name: Shanghai Sunmi Technology Co.,Ltd.
Address : Room 505, KIC Plaza, No.388 Song Hu Road, Yang Pu District,
Shanghai, China
Telephone: 18721763396
Postcode: 200433

1.7. Manufacturer Information

Company Name: Shanghai Sunmi Technology Co.,Ltd.
Address : Room 505, KIC Plaza, No.388 Song Hu Road, Yang Pu District,
Shanghai, China
Telephone: 18721763396
Postcode: 200433

2. Equipment under Test (EUT) and Ancillary Equipment (AE)

2.1. About EUT

EUT Description	POS System
Model name	"T3521" "T3522" "T3523"
Additional Communication Function	BT2.1,3.0,4.0,BLE;WiFi 802.11b,g,n

3.2. Internal Identification of EUT used during the test

EUT ID*	SN or IMEI	HW Version	SW Version	Date of receipt
N04	/	V1.02	1.1.16	2018-08-27
N09	/	V1.02	1.1.17	2018-08-27
N06	/	V1.02	1.1.16	2018-08-27

*EUT ID: is used to identify the test sample in the lab internally.

3.3. Internal Identification of AE used during the test

AE ID*	Description	Model	SN
CA09	Adapter	CYZS36-240150	/
UA03	AC Power Line	/	/
EA02	IOIOI Cable	/	/
AE1	USB Cable	/	/
AE2	LAN Cable	/	/
AE3	Cash Box	/	/
AE4	Keyboard	/	/
AE5	Mouse	/	/
AE6	Notebook PC	DELL Latitude E6510	/
AE7	SanDisk Ultra32GB	Micro SDHC UHS-I	/
AE8	U disk	DT101 G2	/
AE9	Earphone	/	/

*AE ID: is used to identify the test sample in the lab internally.

4. Reference Documents

4.1 Reference Documents for testing

The following documents listed in this section are referred for testing.

Reference	Title	Version
FCC Part 15, Subpart B	Radio frequency devices	10-1-10 Edition
ANSI C63.4	Method of Measurement of Radio-Noise Emissions from Low-Voltage Electrical and Electronic Equipment in the Range of 9 kHz to 40 GHz	2014

5. Test Results

5.1 Summary of Test Results

Items	Test List	Clause in FCC rules	Verdict
1	Radiated Emission	15.109(a)	Pass
2	AC Conducted Emission	15.107(a)	Pass

5.2 Statements

The “T3521” “T3522” “T3523”, supporting BT/WLAN, manufactured by Shanghai Sunmi Technology Co.,Ltd. is a new product for testing. ECIT only performed test cases which identified with Pass/Fail/Inc result in section 5.1.

ECIT has verified that the compliance of the tested device specified in section 3 of this test report is successfully evaluated according to the procedure and test methods as defined in type certification requirement listed in section 4 of this test report.

Note: This project has 3 configured sample N04, N09, N06, and we mainly tested model N04. N09 and N06 configure the sample to test the worst mode of N04.

6. Test Equipment Utilized

6.1 Radiated Emission Equipment list

No.	Name	Type	Series Number	Producer	Cal. Date	Cal. interval
1	Universal Radio Communication	CMU200	123126	R&S	2018-05-11	1 Year
2	Test Receiver	ESU40	100307	R&S	2018-05-11	1 Year
3	Trilog Antenna	VULB9163	VULB9163-515	Schwarzbeck	2017-02-25	3 Year
4	Double Ridged Guide	ETS-3117	00135885	ETS	2017-01-11	3 Year
5	EMI Test Software	EMC32 V9.15	NA	R&S	NA	NA

6.1 AC Conducted Emission Equipment list

No.	Name	Type	Series Number	Producer	Cal. Date	Cal. interval
1	Universal Radio	CMU200	123123	R&S	2018-05-11	1 Year
2	Test Receiver	ESCI	101235	R&S	2018-05-11	1 Year
3	2-Line V-Network	ENV216	101380	R&S	2018-05-11	1 Year
4	EMI Test Software	EMC32 V9.15	NA	R&S	NA	NA

7. System Configuration during Test

7.1 Test Mode

N04 Sample:

Test Item	Function Type
AC Conducted Emission	Mode 1: Full system+CA09+UA03 Mode 2: DATA LINK Mode + CA09+UA03
Radiated Emission	Mode 1: Full system+CA09+UA03 Mode 2: DATA LINK Mode + CA09+UA03
Remark: 1. All test modes are performed, only the worst cases test data are recorded in this report. 2. The full system include LAN cable, cash box, keyboard, mouse, earphone, data link, U disk and note PC.	

N09 Sample:

Test Item	Function Type
AC Conducted Emission	Mode 1: Full system+CA09+UA03
Radiated Emission	Mode 1: Full system+CA09+UA03
Remark: 1. All test modes are performed, only the worst cases test data are recorded in this report. 2. The full system include LAN cable, cash box, keyboard, mouse, earphone, data link, U disk and note PC.	

N06 Sample:

Test Item	Function Type
AC Conducted Emission	Mode 1: Full system+CA09+UA03
Radiated Emission	Mode 1: Full system+CA09+UA03
Remark: 1. All test modes are performed, only the worst cases test data are recorded in this report. 2. The full system include LAN cable, cash box, keyboard, mouse, earphone, data link, U disk and note PC.	

7.2 Connection Diagram of Test System

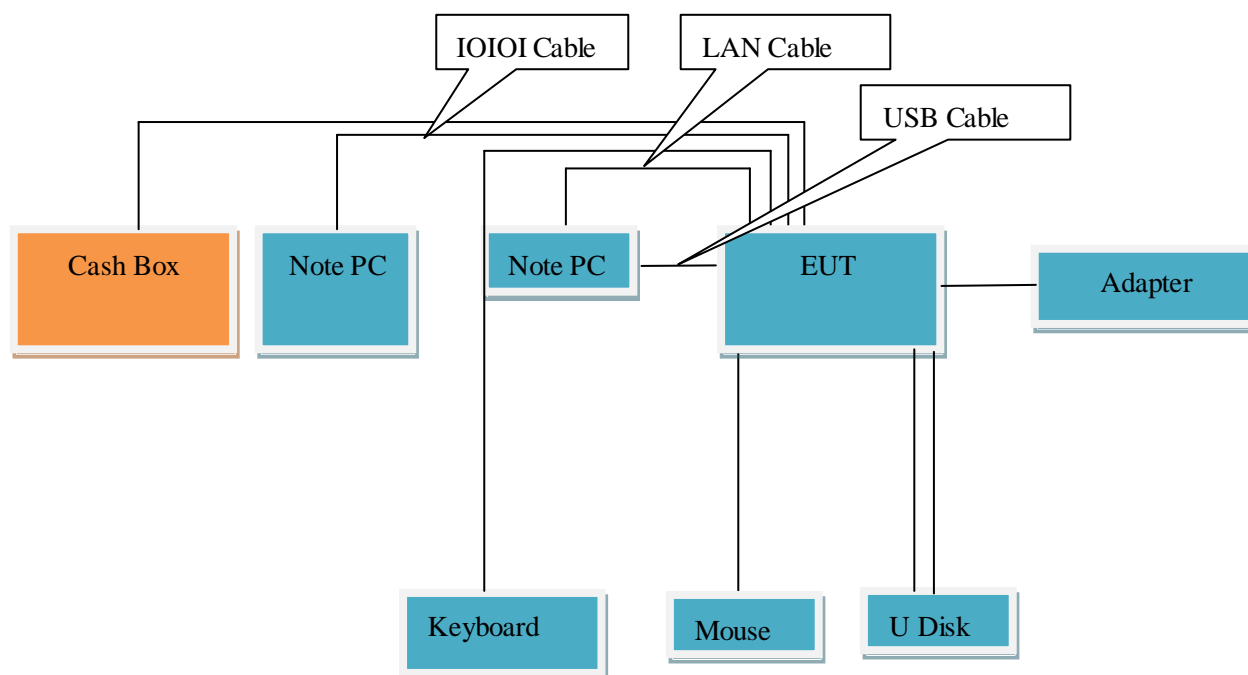

<Figure 1> Mode 1,2

8. Measurement Results

Only the worst test result was shown in this report.

8.1 Radiated Emission 30MHz-18GHz

Method of Measurement

For 30-1000MHz, the EUT was placed on the top of a rotating 0.8-m table above the ground at a semi-anechoic chamber. The distance between the EUT and the received antenna was 3 meters. The table was rotated 360 degree and the received antenna mounted on a variable-height antenna tower was varied from 1m to 4m to find the maximum value of the field strength. Both horizontal and vertical polarizations of the antenna were set during the measurement. Tested in accordance with the procedures of ANSI C63.4-2014, section 8.3.

For 1000-18000MHz, The maximal emission value was acquired by adjusting the antenna height, The table was rotated 360 degree to determine the maximum value of the field strength. Both horizontal and vertical polarizations of the antenna were set during the measurement.

Limits for Radiated Emission at a measuring distance of 3m

Frequency Range (MHz)	Quasi-Peak (dBuV/m)
30-88	40
88-216	43.5
216-960	46
Above 960	54

Frequency Range (MHz)	Peak (dBuV/m)	Average (dBuV/m)
Above 1000	74	54

Test conditions

Frequency Range (MHz)	RBW/VBW	Sweep Time (s)
30-1000	120KHz/300KHz	Auto
1000-18000	1MHz/3MHz	Auto

Uncertainty Measurement

The measurement uncertainty (30MHz-1000MHz) is 4.98 dB (k=2).

The measurement uncertainty (1000MHz-18000MHz) is 5.06 dB (k=2).

Test Results

N04: Mode 1: Full system+CA09+UA03

Frequency Range: 30MHz – 1GHz

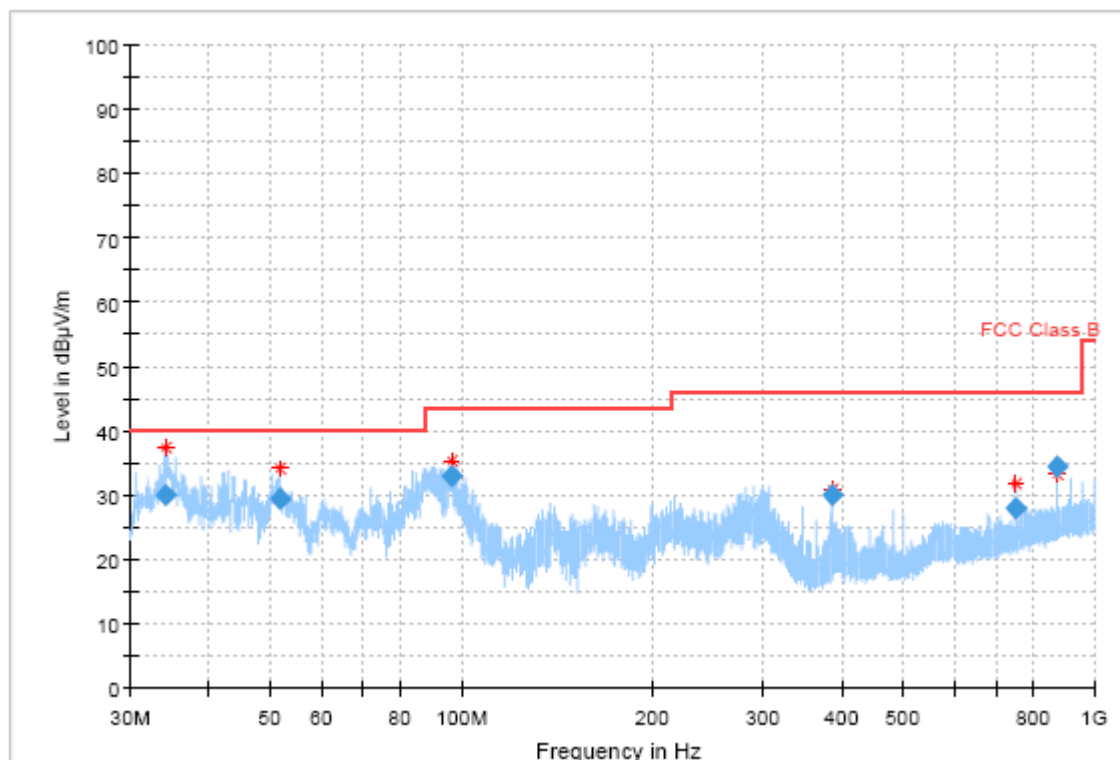

Frequency (MHz)	QuasiPeak (dBµV/m)	Limit (dBµV/m)	Margin (dB)	Meas. Time (ms)	Bandwidth (kHz)	Height (cm)	Pol	Azimuth (deg)	Corr. (dB)
34.112499	30.04	40.00	9.96	1000.0	120.000	100.0	V	88.0	-22.0
51.726677	29.35	40.00	10.65	1000.0	120.000	102.0	V	300.0	-20.4
96.385712	32.96	43.50	10.54	1000.0	120.000	100.0	V	97.0	-24.2
384.003955	30.04	46.00	15.96	1000.0	120.000	100.0	H	122.0	-19.7
749.942592	27.80	46.00	18.20	1000.0	120.000	106.0	H	135.0	-12.2
874.924344	34.50	46.00	11.50	1000.0	120.000	175.0	H	137.0	-10.5

Note:

1. Emission level(QP)=Raw value by receiver + Corr(Antenna factor + cable loss - preamplifier gain)
2. The raw value is used to calculate by software which is not shown in the sheet.
3. Margin=limit value – emission level.

N04: Mode 1: Full system+CA09+UA03

Frequency Range:

1GHz –18GHz

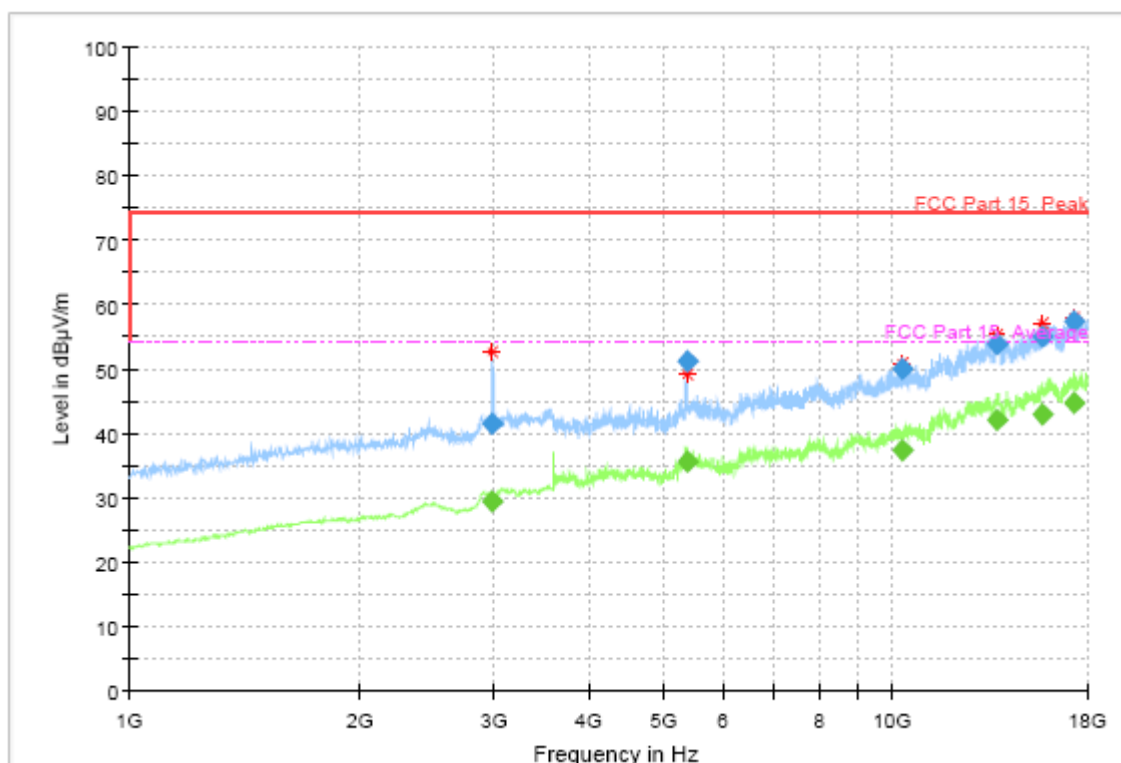

Final Result

Frequency (MHz)	MaxPeak (dBuV/m)	Average (dBuV/m)	Limit (dBuV/m)	Margin (dB)	Meas. Time	Bandwidth (kHz)	Height (cm)	Pol	Azimuth (deg)
2991.600000	41.56	---	74.00	32.44	100.0	1000.000	100.0	H	13.0
2991.600000	---	29.42	54.00	24.58	100.0	1000.000	100.0	H	13.0
5379.400000	---	35.56	54.00	18.44	100.0	1000.000	200.0	H	105.0
5379.400000	51.05	---	74.00	22.95	100.0	1000.000	200.0	H	105.0
10277.800000	---	37.45	54.00	16.55	100.0	1000.000	200.0	H	0.0
10277.800000	50.12	---	74.00	23.88	100.0	1000.000	200.0	H	0.0
13712.200000	---	42.20	54.00	11.80	100.0	1000.000	200.0	H	312.0
13712.200000	53.94	---	74.00	20.06	100.0	1000.000	200.0	H	312.0
15663.800000	55.07	---	74.00	18.93	100.0	1000.000	100.0	H	80.0
15663.800000	---	43.05	54.00	10.95	100.0	1000.000	100.0	H	80.0
17305.600000	---	44.64	54.00	9.36	100.0	1000.000	200.0	H	358.0
17305.600000	57.32	---	74.00	16.68	100.0	1000.000	200.0	H	358.0

Note:

1. Emission level (peak or average) = Raw value by receiver + Corr (Antenna factor + cable loss - preamplifier gain)
2. The raw value is used to calculate by software which is not shown in the sheet.
3. Margin = limit value - emission level.

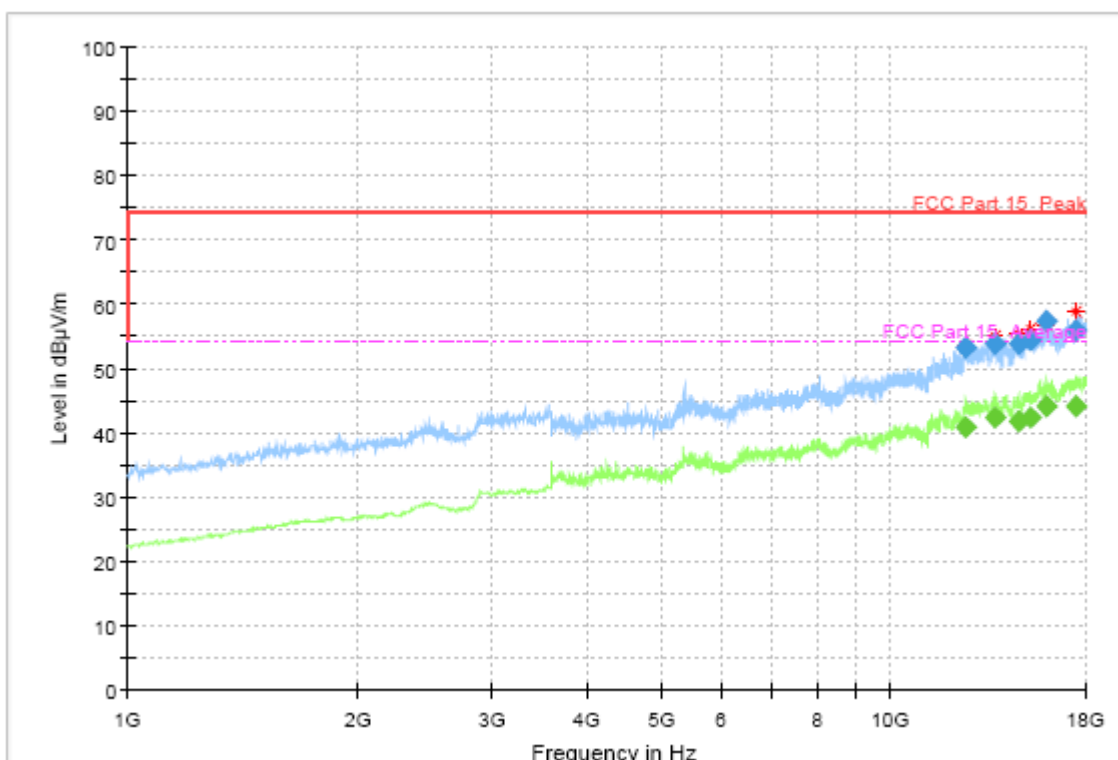

Final Result

Frequency (MHz)	MaxPeak (dBuV/m)	Average (dBuV/m)	Limit (dBuV/m)	Margin (dB)	Meas. Time	Bandwidth (kHz)	Height (cm)	PoI	Azimuth (deg)
12527.000000	---	40.83	54.00	13.17	100.0	1000.000	100.0	V	0.0
12527.000000	53.14	---	74.00	20.86	100.0	1000.000	100.0	V	0.0
13698.600000	53.69	---	74.00	20.31	100.0	1000.000	100.0	V	347.0
13698.600000	---	42.21	54.00	11.79	100.0	1000.000	100.0	V	347.0
14712.200000	---	41.80	54.00	12.20	100.0	1000.000	100.0	V	56.0
14712.200000	53.90	---	74.00	20.10	100.0	1000.000	100.0	V	56.0
15216.200000	54.33	---	74.00	19.67	100.0	1000.000	100.0	V	300.0
15216.200000	---	42.48	54.00	11.52	100.0	1000.000	100.0	V	300.0
16028.600000	57.25	---	74.00	16.75	100.0	1000.000	100.0	V	223.0
16028.600000	---	44.18	54.00	9.82	100.0	1000.000	100.0	V	223.0
17451.600000	55.76	---	74.00	18.24	100.0	1000.000	100.0	V	21.0
17451.600000	---	44.14	54.00	9.86	100.0	1000.000	100.0	V	21.0

Note:

- 1.Emission level(peak or average)=Raw value by receiver + Corr(Antenna factor+ cable loss - preamplifier gain)
- 2.The raw value is used to calculate by software which is not shown in the sheet.
- 3.Margin=limit value – emission level.

N09: Mode 1: Full system+CA09+UA03

Frequency Range:

30MHz – 1GHz

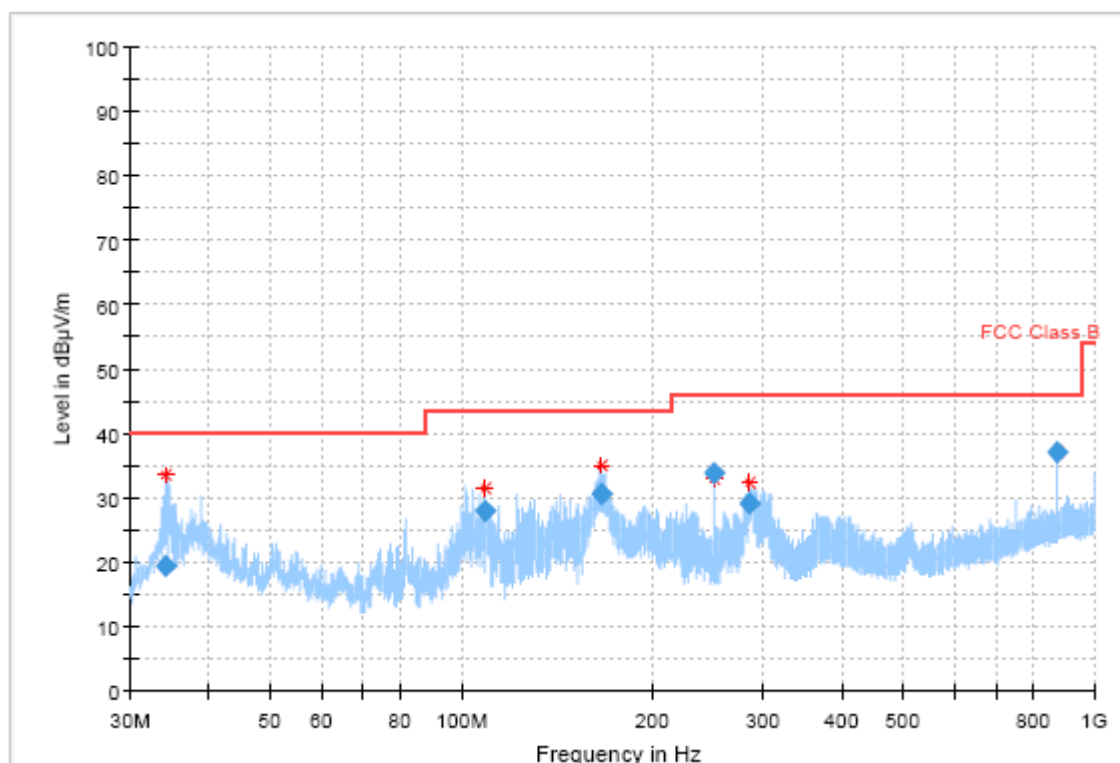

Frequency (MHz)	QuasiPeak (dBµV/m)	Limit (dBµV/m)	Margin (dB)	Meas. Time (ms)	Bandwidth (kHz)	Height (cm)	PoI	Azimuth (deg)	Corr. (dB)
34.225768	19.44	40.00	20.56	1000.0	120.000	100.0	V	101.0	-22.0
108.802973	28.00	43.50	15.50	1000.0	120.000	225.0	H	47.0	-23.8
166.625629	30.69	43.50	12.81	1000.0	120.000	125.0	H	85.0	-26.7
250.005213	33.82	46.00	12.18	1000.0	120.000	100.0	H	-3.0	-23.2
284.381747	29.04	46.00	16.96	1000.0	120.000	100.0	H	140.0	-22.4
874.941432	37.02	46.00	8.98	1000.0	120.000	225.0	H	1.0	-10.5

Note:

1. Emission level(QP)=Raw value by receiver + Corr(Antenna factor + cable loss - preamplifier gain)
2. The raw value is used to calculate by software which is not shown in the sheet.
3. Margin=limit value – emission level.

N09: Mode 1: Full system+CA09+UA03

Frequency Range: 1GHz –18GHz

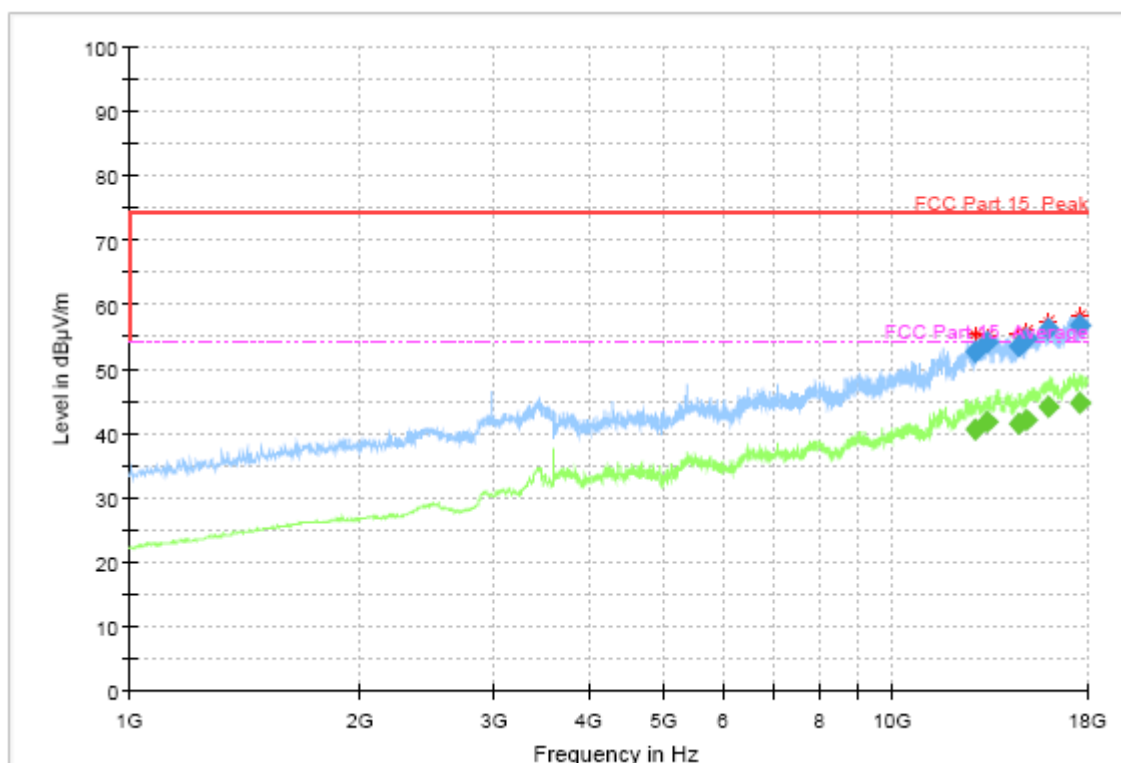

Final Result

Frequency (MHz)	MaxPeak (dBuV/m)	Average (dBuV/m)	Limit (dBuV/m)	Margin (dB)	Meas. Time	Bandwidth (kHz)	Height (cm)	Pol	Azimuth (deg)
12856.400000	52.72	---	74.00	21.28	100.0	1000.000	100.0	H	69.0
12856.400000	---	40.52	54.00	13.48	100.0	1000.000	100.0	H	69.0
13295.400000	54.04	---	74.00	19.96	100.0	1000.000	100.0	H	285.0
13295.400000	---	41.81	54.00	12.19	100.0	1000.000	100.0	H	285.0
14634.800000	53.43	---	74.00	20.57	100.0	1000.000	100.0	H	308.0
14634.800000	---	41.61	54.00	12.39	100.0	1000.000	100.0	H	308.0
14947.400000	---	42.05	54.00	11.95	100.0	1000.000	100.0	H	0.0
14947.400000	54.62	---	74.00	19.38	100.0	1000.000	100.0	H	0.0
16017.000000	---	44.01	54.00	9.99	100.0	1000.000	100.0	H	354.0
16017.000000	56.27	---	74.00	17.73	100.0	1000.000	100.0	H	354.0
17601.400000	56.85	---	74.00	17.15	100.0	1000.000	100.0	H	69.0
17601.400000	---	44.71	54.00	9.29	100.0	1000.000	100.0	H	69.0

Note:

1. Emission level (peak or average) = Raw value by receiver + Corr (Antenna factor + cable loss - preamplifier gain)
2. The raw value is used to calculate by software which is not shown in the sheet.
3. Margin = limit value - emission level.

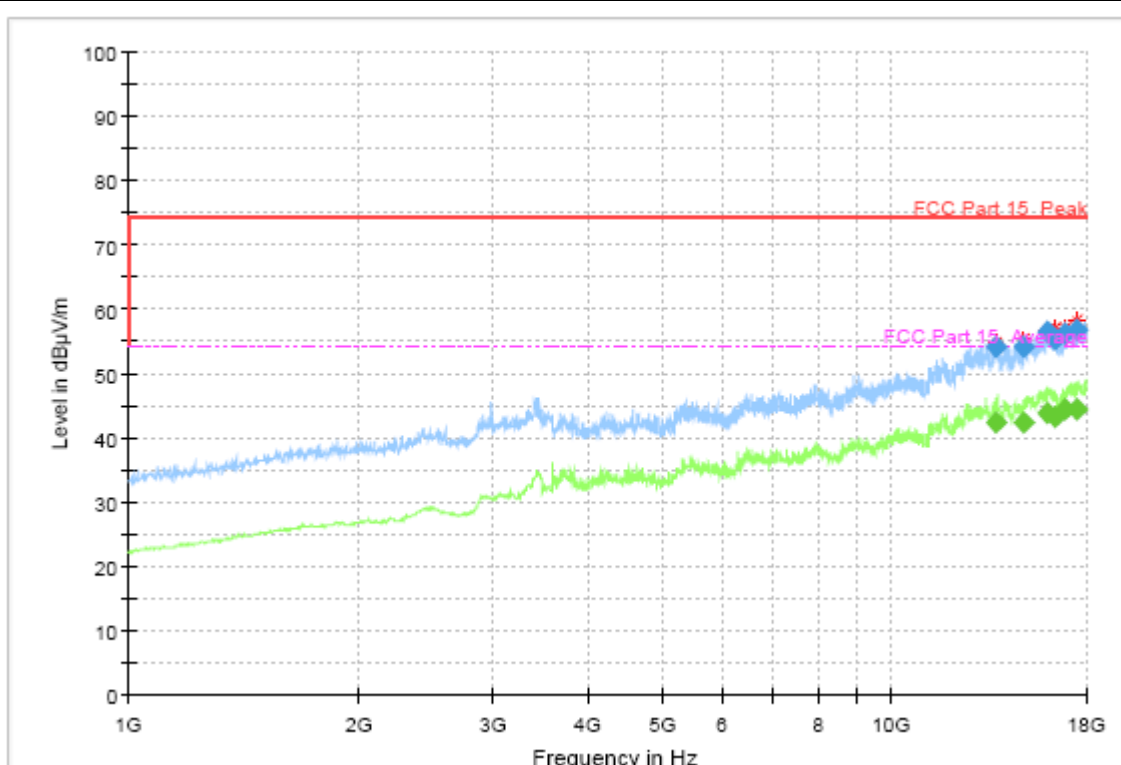

Final Result

Frequency (MHz)	MaxPeak (dBuV/m)	Average (dBuV/m)	Limit (dBuV/m)	Margin (dB)	Meas. Time	Bandwidth (kHz)	Height (cm)	PoI	Azimuth (deg)
13712.000000	54.16	---	74.00	19.84	100.0	1000.000	200.0	V	141.0
13712.000000	---	42.22	54.00	11.78	100.0	1000.000	200.0	V	141.0
14919.200000	---	42.33	54.00	11.67	100.0	1000.000	100.0	V	336.0
14919.200000	54.03	---	74.00	19.97	100.0	1000.000	100.0	V	336.0
15998.200000	56.35	---	74.00	17.65	100.0	1000.000	100.0	V	14.0
15998.200000	---	43.95	54.00	10.05	100.0	1000.000	100.0	V	14.0
16330.000000	---	43.20	54.00	10.80	100.0	1000.000	100.0	V	116.0
16330.000000	55.21	---	74.00	18.79	100.0	1000.000	100.0	V	116.0
16843.200000	56.32	---	74.00	17.68	100.0	1000.000	100.0	V	69.0
16843.200000	---	44.30	54.00	9.70	100.0	1000.000	100.0	V	69.0
17518.200000	56.74	---	74.00	17.26	100.0	1000.000	200.0	V	0.0
17518.200000	---	44.49	54.00	9.51	100.0	1000.000	200.0	V	0.0

Note:

1. Emission level (peak or average) = Raw value by receiver + Corr (Antenna factor + cable loss - preamplifier gain)
2. The raw value is used to calculate by software which is not shown in the sheet.
3. Margin = limit value - emission level.

N06: Mode 1: Full system+CA09+UA03

Frequency Range:

30MHz – 1GHz

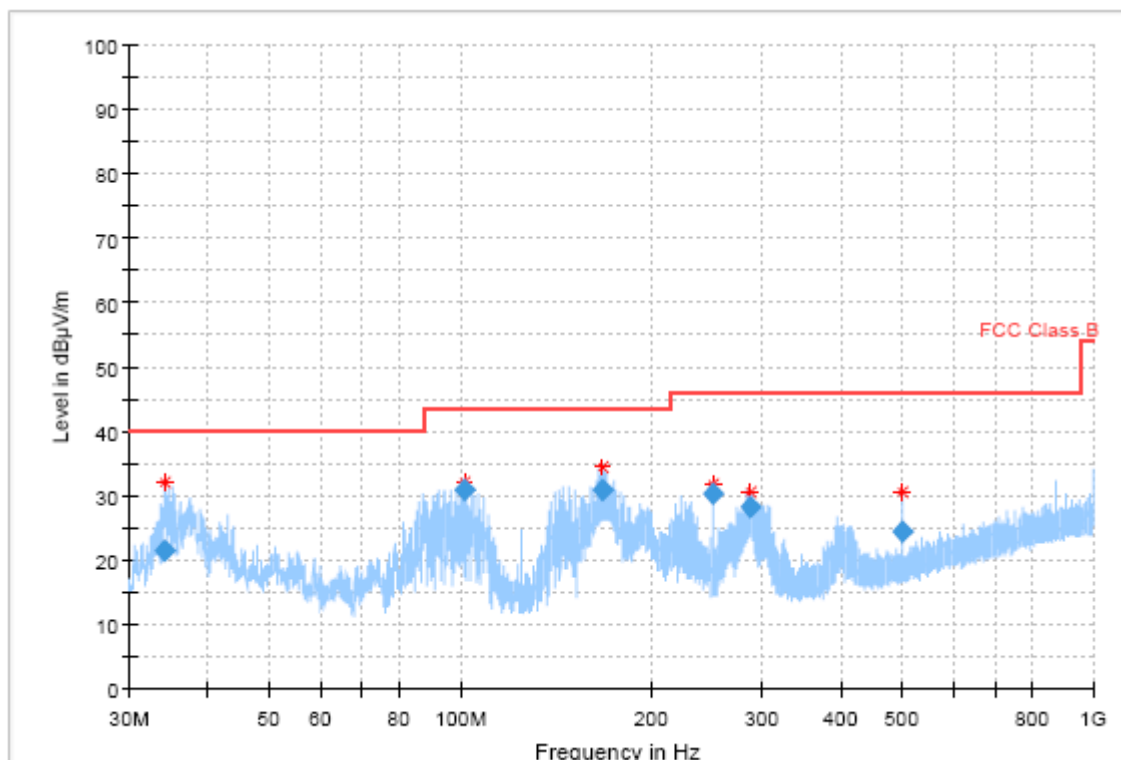

Frequency (MHz)	QuasiPeak (dBµV/m)	Limit (dBµV/m)	Margin (dB)	Meas. Time (ms)	Bandwidth (kHz)	Height (cm)	PoI	Azimuth (deg)	Corr. (dB)
34.145371	21.52	40.00	18.48	1000.0	120.000	100.0	V	94.0	-22.0
101.856776	30.82	43.50	12.68	1000.0	120.000	225.0	H	38.0	-23.6
167.903957	30.82	43.50	12.68	1000.0	120.000	175.0	H	97.0	-26.6
249.992768	30.24	46.00	15.76	1000.0	120.000	107.0	H	-13.0	-23.2
288.184179	28.28	46.00	17.72	1000.0	120.000	100.0	H	154.0	-22.3
499.963800	24.43	46.00	21.57	1000.0	120.000	198.0	H	22.0	-17.1

Note:

1. Emission level(QP)=Raw value by receiver + Corr(Antenna factor + cable loss - preamplifier gain)
2. The raw value is used to calculate by software which is not shown in the sheet.
3. Margin=limit value – emission level.

N06: Mode 1: Full system+CA09+UA03

Frequency Range: 1GHz –18GHz

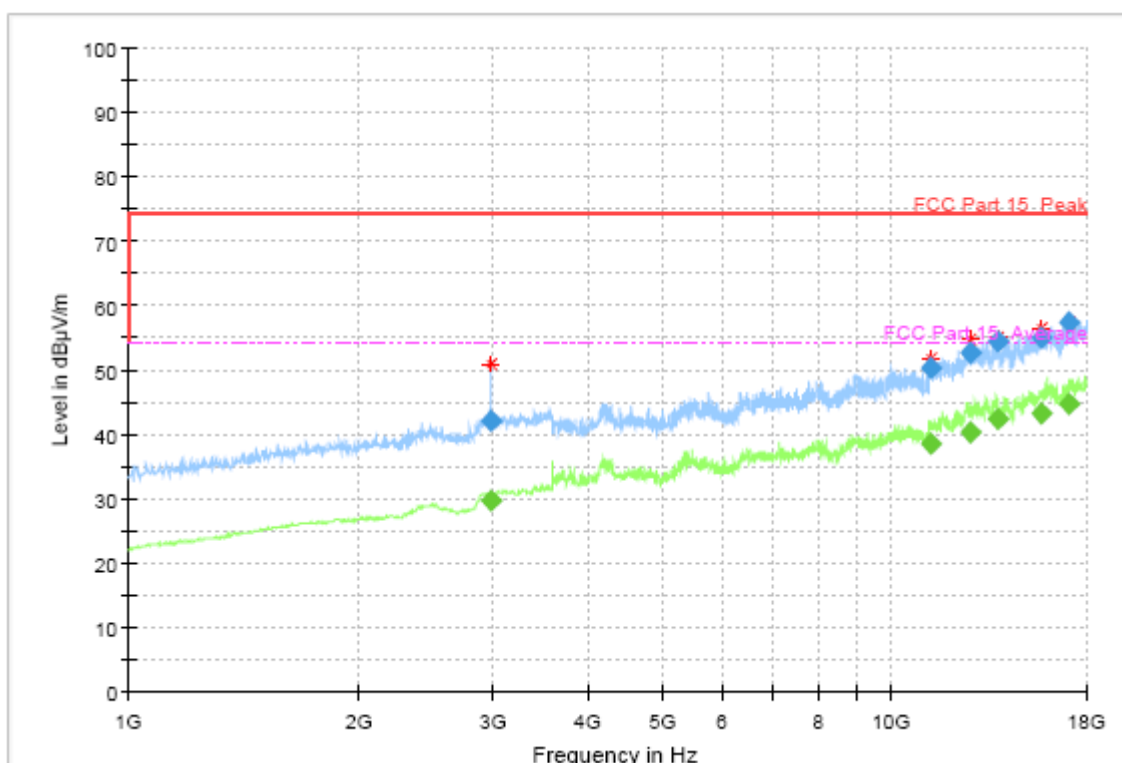

Final Result

Frequency (MHz)	MaxPeak (dBuV/m)	Average (dBuV/m)	Limit (dBuV/m)	Margin (dB)	Meas. Time	Bandwidth (kHz)	Height (cm)	Pol	Azimuth (deg)
2986.400000	---	29.66	54.00	24.34	100.0	1000.000	200.0	H	0.0
2986.400000	41.96	---	74.00	32.04	100.0	1000.000	200.0	H	0.0
11263.600000	---	38.46	54.00	15.54	100.0	1000.000	200.0	H	72.0
11263.600000	50.42	---	74.00	23.58	100.0	1000.000	200.0	H	72.0
12686.000000	52.67	---	74.00	21.33	100.0	1000.000	100.0	H	314.0
12686.000000	---	40.24	54.00	13.76	100.0	1000.000	100.0	H	314.0
13750.400000	---	42.39	54.00	11.61	100.0	1000.000	200.0	H	165.0
13750.400000	54.51	---	74.00	19.49	100.0	1000.000	200.0	H	165.0
15678.600000	---	43.26	54.00	10.74	100.0	1000.000	100.0	H	90.0
15678.600000	54.97	---	74.00	19.03	100.0	1000.000	100.0	H	90.0
17111.600000	57.44	---	74.00	16.56	100.0	1000.000	200.0	H	282.0
17111.600000	---	44.84	54.00	9.16	100.0	1000.000	200.0	H	282.0

Note:

1. Emission level (peak or average) = Raw value by receiver + Corr (Antenna factor + cable loss - preamplifier gain)
2. The raw value is used to calculate by software which is not shown in the sheet.
3. Margin = limit value - emission level.

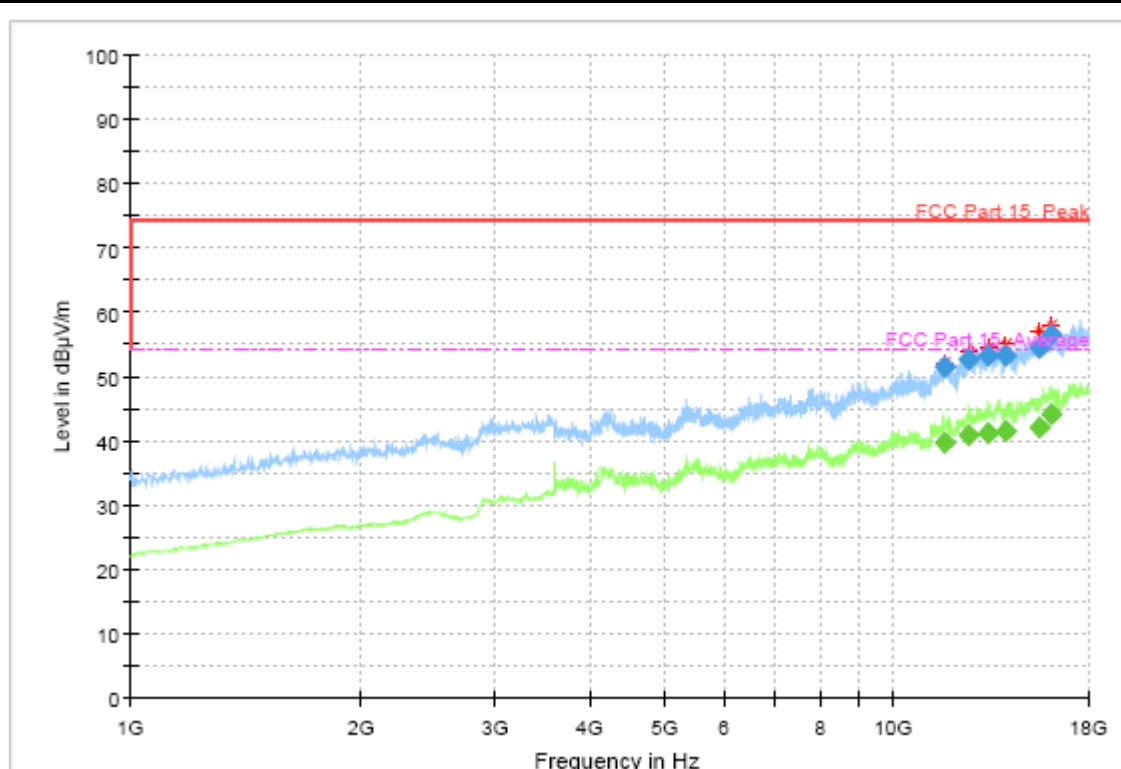

Final Result

Frequency (MHz)	MaxPeak (dBuV/m)	Average (dBuV/m)	Limit (dBuV/m)	Margin (dB)	Meas. Time	Bandwidth (kHz)	Height (cm)	PoI	Azimuth (deg)
11628.800000	51.35	---	74.00	22.65	100.0	1000.000	100.0	V	304.0
11628.800000	---	39.57	54.00	14.43	100.0	1000.000	100.0	V	304.0
12554.200000	52.53	---	74.00	21.47	100.0	1000.000	200.0	V	23.0
12554.200000	---	40.90	54.00	13.10	100.0	1000.000	200.0	V	23.0
13254.400000	53.18	---	74.00	20.82	100.0	1000.000	100.0	V	245.0
13254.400000	---	41.22	54.00	12.78	100.0	1000.000	100.0	V	245.0
14049.200000	---	41.53	54.00	12.47	100.0	1000.000	200.0	V	0.0
14049.200000	53.19	---	74.00	20.81	100.0	1000.000	200.0	V	0.0
15548.200000	---	42.20	54.00	11.80	100.0	1000.000	100.0	V	15.0
15548.200000	54.31	---	74.00	19.69	100.0	1000.000	100.0	V	15.0
16048.800000	56.41	---	74.00	17.59	100.0	1000.000	200.0	V	34.0
16048.800000	---	44.23	54.00	9.77	100.0	1000.000	200.0	V	34.0

Note:

1. Emission level (peak or average) = Raw value by receiver + Corr (Antenna factor + cable loss - preamplifier gain)
2. The raw value is used to calculate by software which is not shown in the sheet.
3. Margin = limit value - emission level.

8.2 Conducted Emission

Method of Measurement

For equipment that is designed to be connected to the public utility (AC) power line, the radio frequency voltage that is conducted back onto the AC power line on any frequency or frequencies with the band 150 kHz to 30MHz shall not exceed the limits. Both lines of the power mains connected to the EUT were checked for maximum conducted interference. Tested in accordance with the procedures of ANSI C63.4-2014, section 7.3

Limit of Conducted Emission

Frequency Range (MHz)	Conducted Limit (dBuV)	
	Quasi-peak	Average
0.15-0.5	66 to 56*	56 to 46*
0.5-5	56	46
5-30	60	50

*Decreases with the logarithm of the frequency

Test Condition in Charging Mode

Voltage (V)	Frequency (Hz)	RBW	Sweep Time (s)
120	60	9 kHz	Auto

Uncertainty Measurement

The measurement uncertainty is 3.66dB (k=2).

Test Results

N04: Mode 1: Full system+CA09+UA03

Frequency Range:

150kHz – 30MHz

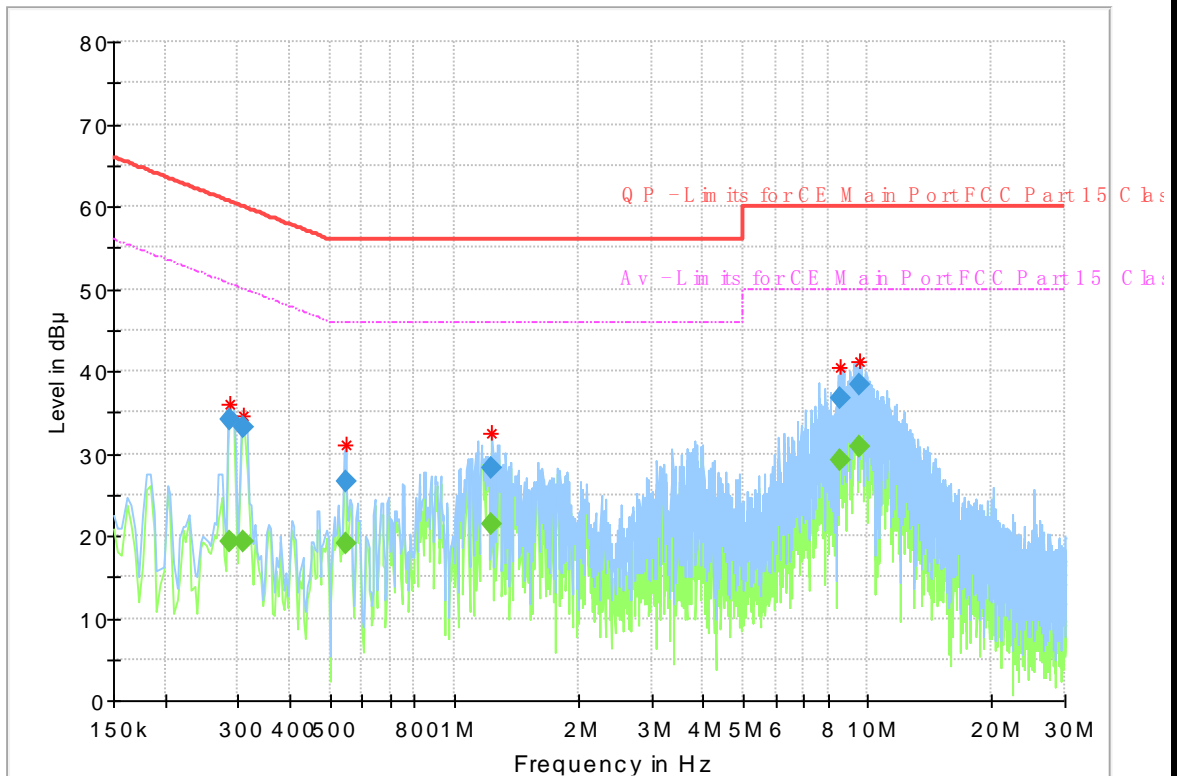

Frequency (MHz)	QuasiPeak (dBµ V)	Average (dBµ V)	Limit (dBµ V)	Margin (dB)	Meas. Time	Bandwidth (kHz)	Line	Filter	Corr. (dB)
0.288056	34.01	---	60.58	26.57	1000.0	9.000	N	ON	9.7
0.288056	---	19.34	50.58	31.24	1000.0	9.000	N	ON	9.7
0.310444	33.18	---	59.96	26.78	1000.0	9.000	N	ON	9.7
0.310444	---	19.20	49.96	30.76	1000.0	9.000	N	ON	9.7
0.545512	---	19.16	46.00	26.84	1000.0	9.000	L1	ON	9.7
0.545512	26.65	---	56.00	29.35	1000.0	9.000	L1	ON	9.7
1.235794	---	21.36	46.00	24.64	1000.0	9.000	L1	ON	9.7
1.235794	28.21	---	56.00	27.79	1000.0	9.000	L1	ON	9.7
8.563969	36.63	---	60.00	23.37	1000.0	9.000	L1	ON	9.8
8.563969	---	29.11	50.00	20.89	1000.0	9.000	L1	ON	9.8
9.552750	---	30.88	50.00	19.12	1000.0	9.000	N	ON	9.8
9.552750	38.46	---	60.00	21.54	1000.0	9.000	N	ON	9.8

Note:

1. Emission level (quasi-peak or Average peak) = Raw value by receiver + Corr (Insertion loss + cable loss)
2. The raw value is used to calculate by software which is not shown in the sheet.
3. Margin = limit value – emission level.

N09: Mode 1: Full system+CA09+UA03

Frequency Range:

150kHz – 30MHz

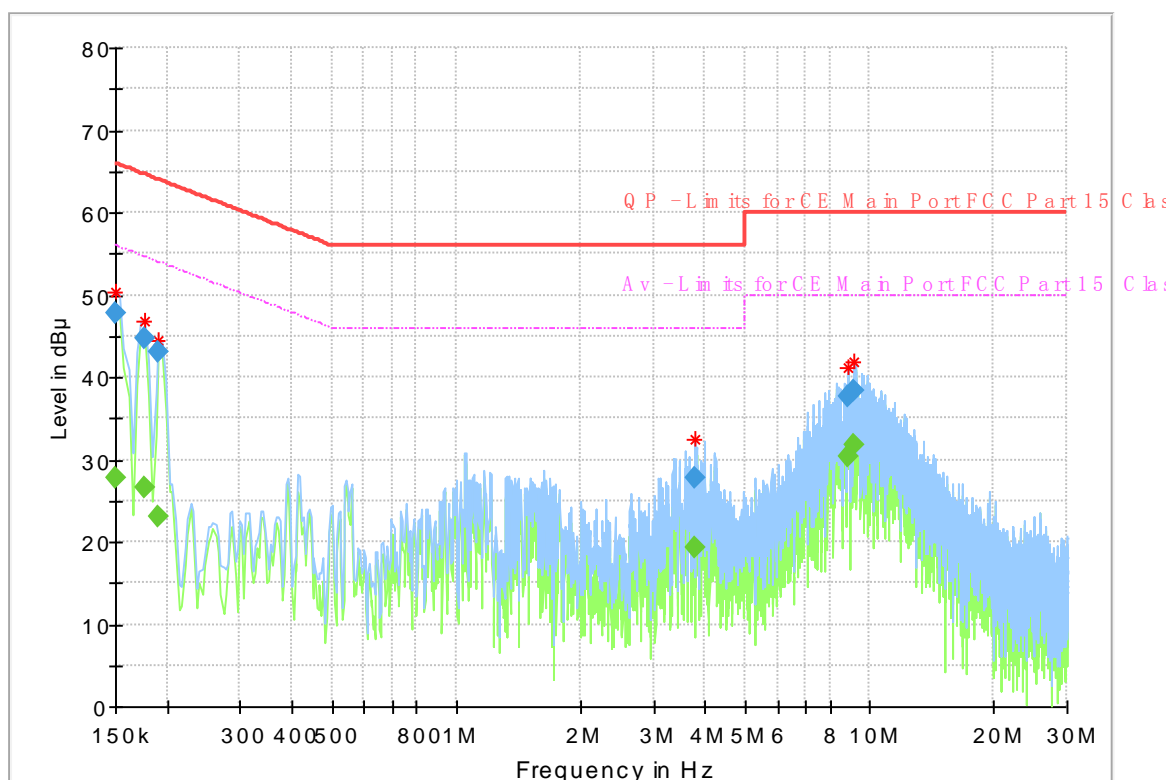

Frequency (MHz)	QuasiPeak (dBµ V)	Average (dBµ V)	Limit (dBµ V)	Margin (dB)	Meas. Time	Bandwidth (kHz)	Line	Filter	Corr. (dB)
0.150000	---	27.86	56.00	28.14	1000.0	9.000	L1	ON	9.7
0.150000	47.74	---	66.00	18.26	1000.0	9.000	L1	ON	9.7
0.176119	---	26.55	54.67	28.12	1000.0	9.000	N	ON	9.7
0.176119	44.82	---	64.67	19.85	1000.0	9.000	N	ON	9.7
0.191044	42.97	---	63.99	21.02	1000.0	9.000	N	ON	9.7
0.191044	---	23.12	53.99	30.87	1000.0	9.000	N	ON	9.7
3.769312	27.77	---	56.00	28.23	1000.0	9.000	L1	ON	9.7
3.769312	---	19.19	46.00	26.81	1000.0	9.000	L1	ON	9.7
8.825156	---	30.44	50.00	19.56	1000.0	9.000	L1	ON	9.8
8.825156	37.60	---	60.00	22.40	1000.0	9.000	L1	ON	9.8
9.198281	---	31.70	50.00	18.30	1000.0	9.000	L1	ON	9.8
9.198281	38.45	---	60.00	21.55	1000.0	9.000	L1	ON	9.8

Note:

1. Emission level (quasi-peak or Average peak) = Raw value by receiver + Corr (Insertion loss + cable loss)
2. The raw value is used to calculate by software which is not shown in the sheet.
3. Margin = limit value – emission level.

N06: Mode 1: Full system+CA09+UA03

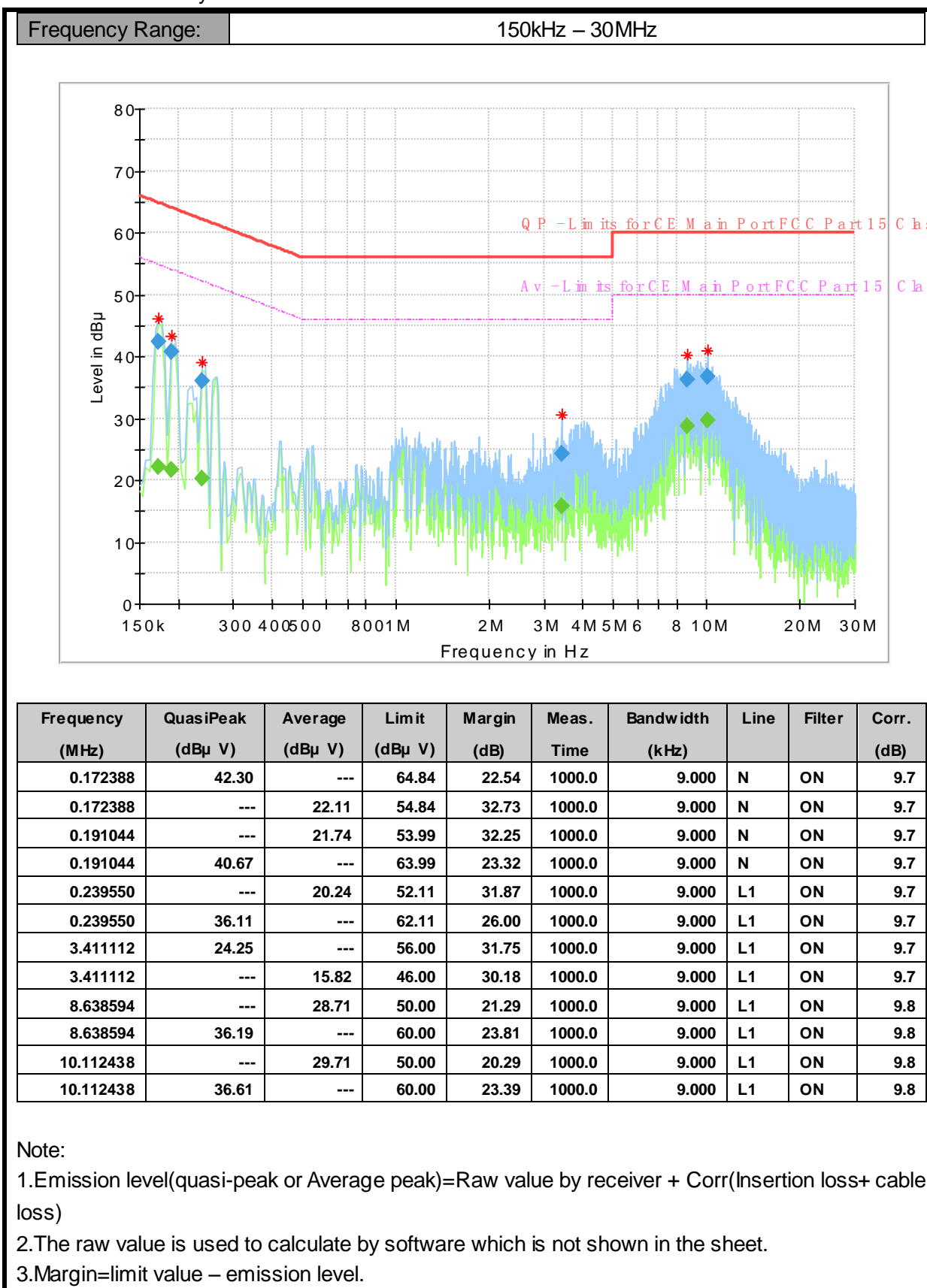

*****END OF REPORT*****