



RF TEST REPORT

Applicant Shanghai Sunmi Technology Co.,Ltd.
FCC ID 2AH25T1711
Product POS system
Brand SUNMI
Model T1711
Report No. R1911A0661-R3V1
Issue Date December 31, 2019

TA Technology (Shanghai) Co., Ltd. tested the above equipment in accordance with the requirements in **FCC CFR47 Part 2 (2018)/ FCC CFR47 Part 27C (2018)**. The test results show that the equipment tested is capable of demonstrating compliance with the requirements as documented in this report.

Performed by: Peng Tao

Approved by: Kai Xu

TA Technology (Shanghai) Co., Ltd.

No.145, Jintang Rd, Tangzhen Industry Park, Pudong Shanghai, China

TEL: +86-021-50791141/2/3

FAX: +86-021-50791141/2/3-8000



TABLE OF CONTENT

1	Test Laboratory	4
1.1	Notes of the Test Report	4
1.2	Test facility	4
1.3	Testing Location	4
2	General Description of Equipment under Test	5
2.1	Applicant and Manufacturer Information	5
2.2	General information	5
3	Applied Standards	6
4	Test Configuration	7
5	Test Case Results	8
5.1	RF Power Output and Effective Radiated Power	8
5.2	Occupied Bandwidth	21
5.3	Band Edge Compliance	34
5.4	Peak-to-Average Power Ratio (PAPR)	50
5.5	Frequency Stability	53
5.6	Spurious Emissions at Antenna Terminals	59
5.7	Radiates Spurious Emission	65
6	Main Test Instruments	71



Summary of Measurement Results

Number	Test Case	Clause in FCC rules	Verdict
1	RF power output and Effective Radiated Power	2.1046/ 27.50(d)(4)/ 27.50(h)(2)	PASS
2	Occupied Bandwidth	2.1049	PASS
3	Band Edge Compliance	27.53(h) /27.53(m)	PASS
4	Peak-to-Average Power Ratio	27.50(d)/KDB971168 D01(5.7)	PASS
5	Frequency Stability	2.1055 / 27.54	PASS
6	Spurious Emissions at Antenna Terminals	2.1051 /27.53(h) /27.53(m)	PASS
7	Radiates Spurious Emission	2.1053 /27.53(h) /27.53(m)	PASS
Note: PASS: The EUT complies with the essential requirements in the standard. FAIL: The EUT does not comply with the essential requirements in the standard.			
Date of Testing: November 13, 2019~ December 2, 2019			



1 Test Laboratory

1.1 Notes of the Test Report

This report shall not be reproduced in full or partial, without the written approval of **TA technology (shanghai) co., Ltd.** The results documented in this report apply only to the tested sample, under the conditions and modes of operation as described herein .Measurement Uncertainties were not taken into account and are published for informational purposes only. This report is written to support regulatory compliance of the applicable standards stated above.

1.2 Test facility

FCC (Designation number: CN1179, Test Firm Registration Number: 446626)

TA Technology (Shanghai) Co., Ltd. has been listed on the US Federal Communications Commission list of test facilities recognized to perform electromagnetic emissions measurements.

1.3 Testing Location

Company: TA Technology (Shanghai) Co., Ltd.
Address: No.145, Jintang Rd, Tangzhen Industry Park, Pudong Shanghai, China
City: Shanghai
Post code: 201201
Country: P. R. China
Contact: Xu Kai
Telephone: +86-021-50791141/2/3
Fax: +86-021-50791141/2/3-8000
Website: <http://www.ta-shanghai.com>
E-mail: xukai@ta-shanghai.com

2 General Description of Equipment under Test

2.1 Applicant and Manufacturer Information

Applicant	Shanghai Sunmi Technology Co.,Ltd.
Applicant address	Room 505, KIC Plaza, No.388 Song Hu Road, Yang Pu District, Shanghai, China
Manufacturer	Shanghai Sunmi Technology Co.,Ltd.
Manufacturer address	Room 505, KIC Plaza, No.388 Song Hu Road, Yang Pu District, Shanghai, China

2.2 General information

EUT Description			
Model	T1711		
SN	DM03D9940005		
Hardware Version	D2MMB60C		
Software Version	V1.0.10		
Power Supply	AC adapter		
Antenna Type	Internal Antenna		
Antenna Gain	LTE Band 4:0.84dBi LTE Band 7:1.33 dBi		
Test Mode(s)	LTE Band 4; LTE Band 7;		
Test Modulation	(LTE)QPSK 16QAM;		
LTE Category	4		
Maximum E.I.R.P.	LTE Band 4:	22.36dBm	
	LTE Band 7:	22.97dBm	
Rated Power Supply Voltage:	24V		
Extreme Voltage	Minimum: 22.8V Maximum: 25.2V		
Extreme Temperature	Lowest: -20°C Highest: +60°C		
Operating Frequency Range(s)	Mode	Tx (MHz)	Rx (MHz)
	LTE Band 4	1710 ~ 1755	2110 ~ 2155
	LTE Band 7	2500 ~ 2570	2620 ~ 2690
EUT Accessory			
Adapter	Manufacturer: Jiangsu Chenyang Electron Co.,Ltd. Model: CYSE65-240250		
Note: 1. The information of the EUT is declared by the manufacturer.			



3 Applied Standards

According to the specifications of the manufacturer, it must comply with the requirements of the following standards:

Test standards:

FCC CFR47 Part 27C (2018)

ANSI C63.26 (2015)

Reference standard:

FCC CFR47 Part 2 (2018)

KDB 971168 D01 Power Meas License Digital Systems v03r01

4 Test Configuration

Radiated measurements are performed by rotating the EUT in three different orthogonal test planes. EUT stand-up position (Z axis), lie-down position (X, Y axis). Receiver antenna polarization (horizontal and vertical), the worst emission was found in position (X axis, vertical polarization) and the worst case was recorded.

All mode and data rates and positions and RB size and modulations were investigated. Subsequently, only the worst case emissions are reported.

The following testing in LTE is set based on the maximum RF Output Power.

The following testing in different Bandwidth is set to detail in the following table:

Test modes are chosen to be reported as the worst case configuration below for LTE Band 4/7:

Test items	Modes	Bandwidth (MHz)						Modulation		RB			Test Channel			
		1.4	3	5	10	15	20	QPSK	16QAM	1	50%	100%	L	M	H	
RF power output and Effective Isotropic Radiated power	LTE 4	O	O	O	O	O	O	O	O	O	O	O	O	O	O	O
	LTE 7	-	-	O	O	O	O	O	O	O	O	O	O	O	O	O
Occupied Bandwidth	LTE 4	O	O	O	O	O	O	O	O	-	-	O	O	O	O	
	LTE 7	-	-	O	O	O	O	O	O	-	-	O	O	O	O	
Band Edge Compliance	LTE 4	O	O	O	O	O	O	O	O	O	-	O	O	-	O	
	LTE 7	-	-	O	O	O	O	O	O	O	-	O	O	-	O	
Peak-to-Average Power Ratio	LTE 4	O	O	O	O	O	O	O	O	-	-	O	O	O	O	
	LTE 7	-	-	O	O	O	O	O	O	-	-	O	O	O	O	
Frequency Stability	LTE 4	O	O	O	O	O	O	O	O	-	-	O	-	O	-	
	LTE 7	-	-	O	O	O	O	O	O	-	-	O	-	O	-	
Spurious Emissions at Antenna Terminals	LTE 4	O	O	O	O	O	O	O	-	O	-	-	O	O	O	
	LTE 7	-	-	O	O	O	O	O	-	O	-	-	O	O	O	
Radiates Spurious Emission	LTE 4	O	-	O	-	-	O	O	-	O	-	-	-	O	-	
	LTE 7	-	-	O	-	O	O	O	-	O	-	-	-	O	-	
Note	1. The mark "O" means that this configuration is chosen for testing. 2. The mark "-" means that this configuration is not testing.															

5 Test Case Results

5.1 RF Power Output and Effective Radiated Power

Ambient condition

Temperature	Relative humidity	Pressure
23°C ~25°C	45%~50%	101.5kPa

Methods of Measurement

During the process of the testing, The EUT is controlled by the Base Station Simulator to ensure max power transmission and proper modulation.

1. The testing follows FCC KDB 971168 D01 v03r01 Section 5.8 and ANSI C63.26 (2015).

- a) Connect the equipment as illustrated. Mount the equipment with the manufacturer specified antenna in a vertical orientation on a manufacturer specified mounting surface located on a non-conducting rotating platform of a RF anechoic chamber (preferred) or a standard radiation site.
- b) Key the transmitter, then rotate the EUT 360° azimuthally and record spectrum analyzer power level (LVL) measurements at angular increments that are sufficiently small to permit resolution of all peaks. If a standard radiation test site is used, raise and lower the test antenna to obtain a maximum reading at each angular increment. (Note: several batteries may be needed to offset the effect of battery voltage droop, which should not exceed 5% of the manufactured specified battery voltage during transmission).
- c) Replace the transmitter under test with a vertically polarized half-wave dipole (or an antenna whose gain is known relative to an ideal half-wave dipole). The center of the antenna should be at the same location as the center of the antenna under test.
- d) Connect the antenna to a signal generator with a known output power and record the path loss (in dB) as LOSS. If a standard radiation test site is used, raise and lower the test antenna to obtain a maximum reading. $LOSS = \text{Generator Output Power (dBm)} - \text{Analyzer reading (dBm)}$
- e) Determine the effective radiated output power at each angular position from the readings in steps b) and d) using the following equation: $ERP \text{ (dBm)} = \text{LVL (dBm)} + \text{LOSS (dB)}$
- f) The maximum ERP is the maximum value determined in the preceding step.
- g) When calculating ERP, in addition to knowing the antenna radiation and matching characteristics, it is necessary to know the loss values of all elements (e.g. transmission line attenuation, mismatches, filters, combiners) interposed between the point where transmitter output power is measured, and the point where power is applied to the antenna. ERP can then be calculated as follows:

$$EIRP \text{ (dBm)} = \text{Output Power (dBm)} - \text{Losses (dB)} + \text{Antenna Gain (dBi)}$$

where: dBd refers to gain relative to an ideal dipole.

$$EIRP \text{ (dBm)} = ERP \text{ (dBm)} + 2.15 \text{ (dB.)}$$

The RB allocation refers to section 5.1, using the maximum output power configuration.

Test Setup

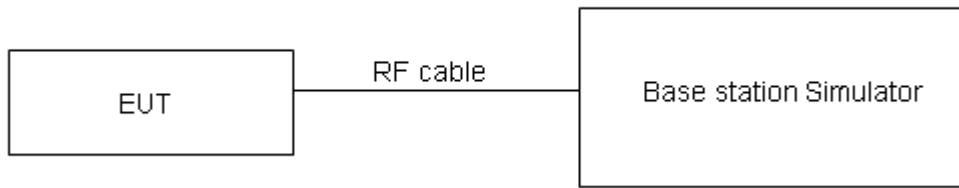

The loss between RF output port of the EUT and the input port of the tester has been taken into consideration.

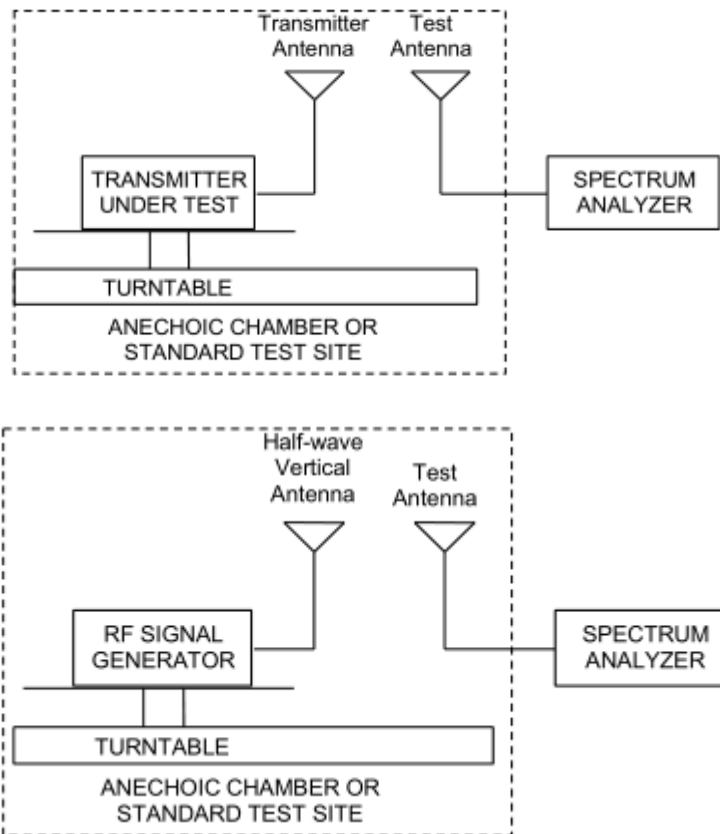

Note: Area side:2.4mX3.6m

The radiated emission was measured in the following position: EUT stand-up position (Z axis), lie-down position (X, Y axis). The worst emission was found in stand-up position (Z axis) and the worst case was recorded.

Limits

No specific RF power output requirements in part 2.1046.

Rule Part 27.50(d) (4) specifies that “Fixed, mobile and portable (hand-held) stations operating in the 1710–1755 MHz band are limited to 1 watt EIRP”

Rule Part 27.50(h) (2) specifies that “Mobile and other user stations. Mobile stations are limited to 2.0 watts EIRP. All user stations are limited to 2.0 watts transmitter output power.”



Part 27.50(d)(4)Limit	$\leq 1 \text{ W}$ (30 dBm)
Part 27.50(h)(2) Limit	$\leq 2 \text{ W}$ (33 dBm)

Measurement Uncertainty

The assessed measurement uncertainty to ensure 95% confidence level for the normal distribution is with the coverage factor $k = 2$, $U=0.4$ dB for RF power output, $k = 2$, $U= 1.19$ dB for EIRP.



Test Results

Band	Bandwidth (MHz)	UL Channel	RB Size	RB Position	Modulation	Power (dBm)	EIRP
LTE Band4	1.4	19957	1	#0	QPSK	21.27	22.11
LTE Band4	1.4	19957	1	#Mid	QPSK	21.52	22.36
LTE Band4	1.4	19957	1	#Max	QPSK	21.32	22.16
LTE Band4	1.4	19957	3	#0	QPSK	21.18	22.02
LTE Band4	1.4	19957	3	#Mid	QPSK	21.18	22.02
LTE Band4	1.4	19957	3	#Max	QPSK	21.15	21.99
LTE Band4	1.4	19957	6	#0	QPSK	20.29	21.13
LTE Band4	1.4	19957	1	#0	QAM16	20.48	21.32
LTE Band4	1.4	19957	1	#Mid	QAM16	20.64	21.48
LTE Band4	1.4	19957	1	#Max	QAM16	20.46	21.30
LTE Band4	1.4	19957	3	#0	QAM16	20.25	21.09
LTE Band4	1.4	19957	3	#Mid	QAM16	20.17	21.01
LTE Band4	1.4	19957	3	#Max	QAM16	20.25	21.09
LTE Band4	1.4	19957	6	#0	QAM16	19.00	19.84
LTE Band4	1.4	20175	1	#0	QPSK	21.13	21.97
LTE Band4	1.4	20175	1	#Mid	QPSK	21.29	22.13
LTE Band4	1.4	20175	1	#Max	QPSK	20.95	21.79
LTE Band4	1.4	20175	3	#0	QPSK	20.81	21.65
LTE Band4	1.4	20175	3	#Mid	QPSK	20.95	21.79
LTE Band4	1.4	20175	3	#Max	QPSK	21.00	21.84
LTE Band4	1.4	20175	6	#0	QPSK	19.90	20.74
LTE Band4	1.4	20175	1	#0	QAM16	20.08	20.92
LTE Band4	1.4	20175	1	#Mid	QAM16	20.42	21.26
LTE Band4	1.4	20175	1	#Max	QAM16	20.17	21.01
LTE Band4	1.4	20175	3	#0	QAM16	19.90	20.74
LTE Band4	1.4	20175	3	#Mid	QAM16	19.90	20.74
LTE Band4	1.4	20175	3	#Max	QAM16	20.13	20.97
LTE Band4	1.4	20175	6	#0	QAM16	18.93	19.77
LTE Band4	1.4	20393	1	#0	QPSK	20.81	21.65
LTE Band4	1.4	20393	1	#Mid	QPSK	20.70	21.54
LTE Band4	1.4	20393	1	#Max	QPSK	20.68	21.52
LTE Band4	1.4	20393	3	#0	QPSK	20.77	21.61
LTE Band4	1.4	20393	3	#Mid	QPSK	20.69	21.53
LTE Band4	1.4	20393	3	#Max	QPSK	20.57	21.41
LTE Band4	1.4	20393	6	#0	QPSK	19.80	20.64
LTE Band4	1.4	20393	1	#0	QAM16	19.13	19.97
LTE Band4	1.4	20393	1	#Mid	QAM16	19.18	20.02
LTE Band4	1.4	20393	1	#Max	QAM16	19.00	19.84
LTE Band4	1.4	20393	3	#0	QAM16	19.50	20.34
LTE Band4	1.4	20393	3	#Mid	QAM16	19.49	20.33



LTE Band4	1.4	20393	3	#Max	QAM16	19.76	20.60
LTE Band4	1.4	20393	6	#0	QAM16	18.93	19.77
LTE Band4	3	19965	1	#0	QPSK	21.02	21.86
LTE Band4	3	19965	1	#Mid	QPSK	20.73	21.57
LTE Band4	3	19965	1	#Max	QPSK	20.91	21.75
LTE Band4	3	19965	8	#0	QPSK	20.15	20.99
LTE Band4	3	19965	8	#Mid	QPSK	20.16	21.00
LTE Band4	3	19965	8	#Max	QPSK	20.08	20.92
LTE Band4	3	19965	15	#0	QPSK	20.19	21.03
LTE Band4	3	19965	1	#0	QAM16	20.17	21.01
LTE Band4	3	19965	1	#Mid	QAM16	19.91	20.75
LTE Band4	3	19965	1	#Max	QAM16	19.92	20.76
LTE Band4	3	19965	8	#0	QAM16	18.89	19.73
LTE Band4	3	19965	8	#Mid	QAM16	18.90	19.74
LTE Band4	3	19965	8	#Max	QAM16	18.77	19.61
LTE Band4	3	19965	15	#0	QAM16	18.86	19.70
LTE Band4	3	20175	1	#0	QPSK	20.89	21.73
LTE Band4	3	20175	1	#Mid	QPSK	20.76	21.60
LTE Band4	3	20175	1	#Max	QPSK	20.97	21.81
LTE Band4	3	20175	8	#0	QPSK	19.73	20.57
LTE Band4	3	20175	8	#Mid	QPSK	19.74	20.58
LTE Band4	3	20175	8	#Max	QPSK	20.05	20.89
LTE Band4	3	20175	15	#0	QPSK	20.01	20.85
LTE Band4	3	20175	1	#0	QAM16	20.18	21.02
LTE Band4	3	20175	1	#Mid	QAM16	20.49	21.33
LTE Band4	3	20175	1	#Max	QAM16	20.70	21.54
LTE Band4	3	20175	8	#0	QAM16	18.60	19.44
LTE Band4	3	20175	8	#Mid	QAM16	18.61	19.45
LTE Band4	3	20175	8	#Max	QAM16	18.81	19.65
LTE Band4	3	20175	15	#0	QAM16	18.59	19.43
LTE Band4	3	20385	1	#0	QPSK	20.84	21.68
LTE Band4	3	20385	1	#Mid	QPSK	20.45	21.29
LTE Band4	3	20385	1	#Max	QPSK	20.62	21.46
LTE Band4	3	20385	8	#0	QPSK	19.75	20.59
LTE Band4	3	20385	8	#Mid	QPSK	19.78	20.62
LTE Band4	3	20385	8	#Max	QPSK	19.53	20.37
LTE Band4	3	20385	15	#0	QPSK	19.69	20.53
LTE Band4	3	20385	1	#0	QAM16	19.20	20.04
LTE Band4	3	20385	1	#Mid	QAM16	18.97	19.81
LTE Band4	3	20385	1	#Max	QAM16	19.11	19.95
LTE Band4	3	20385	8	#0	QAM16	18.75	19.59
LTE Band4	3	20385	8	#Mid	QAM16	18.77	19.61
LTE Band4	3	20385	8	#Max	QAM16	18.74	19.58



LTE Band4	3	20385	15	#0	QAM16	18.74	19.58
LTE Band4	5	19975	1	#0	QPSK	20.98	21.82
LTE Band4	5	19975	1	#Mid	QPSK	20.79	21.63
LTE Band4	5	19975	1	#Max	QPSK	21.01	21.85
LTE Band4	5	19975	12	#0	QPSK	19.99	20.83
LTE Band4	5	19975	12	#Mid	QPSK	20.00	20.84
LTE Band4	5	19975	12	#Max	QPSK	19.85	20.69
LTE Band4	5	19975	25	#0	QPSK	20.08	20.92
LTE Band4	5	19975	1	#0	QAM16	19.85	20.69
LTE Band4	5	19975	1	#Mid	QAM16	19.58	20.42
LTE Band4	5	19975	1	#Max	QAM16	19.46	20.30
LTE Band4	5	19975	12	#0	QAM16	18.89	19.73
LTE Band4	5	19975	12	#Mid	QAM16	18.90	19.74
LTE Band4	5	19975	12	#Max	QAM16	18.81	19.65
LTE Band4	5	19975	25	#0	QAM16	19.20	20.04
LTE Band4	5	20175	1	#0	QPSK	20.64	21.48
LTE Band4	5	20175	1	#Mid	QPSK	20.73	21.57
LTE Band4	5	20175	1	#Max	QPSK	20.69	21.53
LTE Band4	5	20175	12	#0	QPSK	19.81	20.65
LTE Band4	5	20175	12	#Mid	QPSK	19.81	20.65
LTE Band4	5	20175	12	#Max	QPSK	20.00	20.84
LTE Band4	5	20175	25	#0	QPSK	19.81	20.65
LTE Band4	5	20175	1	#0	QAM16	19.87	20.71
LTE Band4	5	20175	1	#Mid	QAM16	20.00	20.84
LTE Band4	5	20175	1	#Max	QAM16	20.37	21.21
LTE Band4	5	20175	12	#0	QAM16	18.55	19.39
LTE Band4	5	20175	12	#Mid	QAM16	18.56	19.40
LTE Band4	5	20175	12	#Max	QAM16	18.83	19.67
LTE Band4	5	20175	25	#0	QAM16	18.67	19.51
LTE Band4	5	20375	1	#0	QPSK	20.56	21.40
LTE Band4	5	20375	1	#Mid	QPSK	20.61	21.45
LTE Band4	5	20375	1	#Max	QPSK	20.71	21.55
LTE Band4	5	20375	12	#0	QPSK	19.59	20.43
LTE Band4	5	20375	12	#Mid	QPSK	19.65	20.49
LTE Band4	5	20375	12	#Max	QPSK	19.67	20.51
LTE Band4	5	20375	25	#0	QPSK	19.64	20.48
LTE Band4	5	20375	1	#0	QAM16	19.65	20.49
LTE Band4	5	20375	1	#Mid	QAM16	19.26	20.10
LTE Band4	5	20375	1	#Max	QAM16	19.33	20.17
LTE Band4	5	20375	12	#0	QAM16	18.72	19.56
LTE Band4	5	20375	12	#Mid	QAM16	18.76	19.60
LTE Band4	5	20375	12	#Max	QAM16	18.58	19.42
LTE Band4	5	20375	25	#0	QAM16	18.77	19.61



LTE Band4	10	20000	1	#0	QPSK	21.11	21.95
LTE Band4	10	20000	1	#Mid	QPSK	21.03	21.87
LTE Band4	10	20000	1	#Max	QPSK	20.95	21.79
LTE Band4	10	20000	25	#0	QPSK	20.01	20.85
LTE Band4	10	20000	25	#Mid	QPSK	20.03	20.87
LTE Band4	10	20000	25	#Max	QPSK	19.82	20.66
LTE Band4	10	20000	50	#0	QPSK	19.96	20.80
LTE Band4	10	20000	1	#0	QAM16	20.66	21.50
LTE Band4	10	20000	1	#Mid	QAM16	20.21	21.05
LTE Band4	10	20000	1	#Max	QAM16	19.42	20.26
LTE Band4	10	20000	25	#0	QAM16	19.17	20.01
LTE Band4	10	20000	25	#Mid	QAM16	19.19	20.03
LTE Band4	10	20000	25	#Max	QAM16	18.91	19.75
LTE Band4	10	20000	50	#0	QAM16	19.04	19.88
LTE Band4	10	20175	1	#0	QPSK	20.81	21.65
LTE Band4	10	20175	1	#Mid	QPSK	21.10	21.94
LTE Band4	10	20175	1	#Max	QPSK	20.88	21.72
LTE Band4	10	20175	25	#0	QPSK	19.81	20.65
LTE Band4	10	20175	25	#Mid	QPSK	19.80	20.64
LTE Band4	10	20175	25	#Max	QPSK	19.83	20.67
LTE Band4	10	20175	50	#0	QPSK	19.77	20.61
LTE Band4	10	20175	1	#0	QAM16	20.41	21.25
LTE Band4	10	20175	1	#Mid	QAM16	20.94	21.78
LTE Band4	10	20175	1	#Max	QAM16	20.81	21.65
LTE Band4	10	20175	25	#0	QAM16	18.64	19.48
LTE Band4	10	20175	25	#Mid	QAM16	18.81	19.65
LTE Band4	10	20175	25	#Max	QAM16	19.02	19.86
LTE Band4	10	20175	50	#0	QAM16	18.73	19.57
LTE Band4	10	20350	1	#0	QPSK	21.06	21.90
LTE Band4	10	20350	1	#Mid	QPSK	20.76	21.60
LTE Band4	10	20350	1	#Max	QPSK	20.67	21.51
LTE Band4	10	20350	25	#0	QPSK	19.74	20.58
LTE Band4	10	20350	25	#Mid	QPSK	19.72	20.56
LTE Band4	10	20350	25	#Max	QPSK	19.53	20.37
LTE Band4	10	20350	50	#0	QPSK	19.69	20.53
LTE Band4	10	20350	1	#0	QAM16	20.23	21.07
LTE Band4	10	20350	1	#Mid	QAM16	19.17	20.01
LTE Band4	10	20350	1	#Max	QAM16	19.14	19.98
LTE Band4	10	20350	25	#0	QAM16	18.79	19.63
LTE Band4	10	20350	25	#Mid	QAM16	18.74	19.58
LTE Band4	10	20350	25	#Max	QAM16	18.51	19.35
LTE Band4	10	20350	50	#0	QAM16	18.68	19.52
LTE Band4	15	20025	1	#0	QPSK	21.13	21.97



LTE Band4	15	20025	1	#Mid	QPSK	20.83	21.67
LTE Band4	15	20025	1	#Max	QPSK	20.95	21.79
LTE Band4	15	20025	36	#0	QPSK	19.94	20.78
LTE Band4	15	20025	36	#Mid	QPSK	19.96	20.80
LTE Band4	15	20025	36	#Max	QPSK	19.80	20.64
LTE Band4	15	20025	75	#0	QPSK	19.84	20.68
LTE Band4	15	20025	1	#0	QAM16	20.75	21.59
LTE Band4	15	20025	1	#Mid	QAM16	19.61	20.45
LTE Band4	15	20025	1	#Max	QAM16	19.94	20.78
LTE Band4	15	20025	36	#0	QAM16	18.83	19.67
LTE Band4	15	20025	36	#Mid	QAM16	18.85	19.69
LTE Band4	15	20025	36	#Max	QAM16	18.77	19.61
LTE Band4	15	20025	75	#0	QAM16	19.02	19.86
LTE Band4	15	20175	1	#0	QPSK	20.76	21.60
LTE Band4	15	20175	1	#Mid	QPSK	20.94	21.78
LTE Band4	15	20175	1	#Max	QPSK	20.86	21.70
LTE Band4	15	20175	36	#0	QPSK	19.71	20.55
LTE Band4	15	20175	36	#Mid	QPSK	19.70	20.54
LTE Band4	15	20175	36	#Max	QPSK	19.72	20.56
LTE Band4	15	20175	75	#0	QPSK	19.69	20.53
LTE Band4	15	20175	1	#0	QAM16	20.23	21.07
LTE Band4	15	20175	1	#Mid	QAM16	20.37	21.21
LTE Band4	15	20175	1	#Max	QAM16	20.88	21.72
LTE Band4	15	20175	36	#0	QAM16	18.51	19.35
LTE Band4	15	20175	36	#Mid	QAM16	18.51	19.35
LTE Band4	15	20175	36	#Max	QAM16	18.79	19.63
LTE Band4	15	20175	75	#0	QAM16	18.65	19.49
LTE Band4	15	20325	1	#0	QPSK	20.77	21.61
LTE Band4	15	20325	1	#Mid	QPSK	20.70	21.54
LTE Band4	15	20325	1	#Max	QPSK	20.59	21.43
LTE Band4	15	20325	36	#0	QPSK	19.84	20.68
LTE Band4	15	20325	36	#Mid	QPSK	19.87	20.71
LTE Band4	15	20325	36	#Max	QPSK	19.55	20.39
LTE Band4	15	20325	75	#0	QPSK	19.78	20.62
LTE Band4	15	20325	1	#0	QAM16	19.65	20.49
LTE Band4	15	20325	1	#Mid	QAM16	19.38	20.22
LTE Band4	15	20325	1	#Max	QAM16	19.03	19.87
LTE Band4	15	20325	36	#0	QAM16	18.84	19.68
LTE Band4	15	20325	36	#Mid	QAM16	18.84	19.68
LTE Band4	15	20325	36	#Max	QAM16	18.66	19.50
LTE Band4	15	20325	75	#0	QAM16	18.83	19.67
LTE Band4	20	20050	1	#0	QPSK	20.89	21.73
LTE Band4	20	20050	1	#Mid	QPSK	20.60	21.44



LTE Band4	20	20050	1	#Max	QPSK	20.75	21.59
LTE Band4	20	20050	50	#0	QPSK	19.84	20.68
LTE Band4	20	20050	50	#Mid	QPSK	19.86	20.70
LTE Band4	20	20050	50	#Max	QPSK	19.73	20.57
LTE Band4	20	20050	100	#0	QPSK	19.82	20.66
LTE Band4	20	20050	1	#0	QAM16	20.33	21.17
LTE Band4	20	20050	1	#Mid	QAM16	20.28	21.12
LTE Band4	20	20050	1	#Max	QAM16	20.07	20.91
LTE Band4	20	20050	50	#0	QAM16	18.87	19.71
LTE Band4	20	20050	50	#Mid	QAM16	18.87	19.71
LTE Band4	20	20050	50	#Max	QAM16	18.88	19.72
LTE Band4	20	20050	100	#0	QAM16	18.91	19.75
LTE Band4	20	20175	1	#0	QPSK	20.70	21.54
LTE Band4	20	20175	1	#Mid	QPSK	21.08	21.92
LTE Band4	20	20175	1	#Max	QPSK	21.07	21.91
LTE Band4	20	20175	50	#0	QPSK	19.59	20.43
LTE Band4	20	20175	50	#Mid	QPSK	19.58	20.42
LTE Band4	20	20175	50	#Max	QPSK	19.76	20.60
LTE Band4	20	20175	100	#0	QPSK	19.61	20.45
LTE Band4	20	20175	1	#0	QAM16	19.39	20.23
LTE Band4	20	20175	1	#Mid	QAM16	19.45	20.29
LTE Band4	20	20175	1	#Max	QAM16	19.41	20.25
LTE Band4	20	20175	50	#0	QAM16	18.62	19.46
LTE Band4	20	20175	50	#Mid	QAM16	18.73	19.57
LTE Band4	20	20175	50	#Max	QAM16	18.81	19.65
LTE Band4	20	20175	100	#0	QAM16	18.71	19.55
LTE Band4	20	20300	1	#0	QPSK	20.76	21.60
LTE Band4	20	20300	1	#Mid	QPSK	21.07	21.91
LTE Band4	20	20300	1	#Max	QPSK	20.61	21.45
LTE Band4	20	20300	50	#0	QPSK	19.81	20.65
LTE Band4	20	20300	50	#Mid	QPSK	19.87	20.71
LTE Band4	20	20300	50	#Max	QPSK	19.69	20.53
LTE Band4	20	20300	100	#0	QPSK	19.73	20.57
LTE Band4	20	20300	1	#0	QAM16	19.64	20.48
LTE Band4	20	20300	1	#Mid	QAM16	20.07	20.91
LTE Band4	20	20300	1	#Max	QAM16	19.39	20.23
LTE Band4	20	20300	50	#0	QAM16	18.92	19.76
LTE Band4	20	20300	50	#Mid	QAM16	18.87	19.71
LTE Band4	20	20300	50	#Max	QAM16	18.60	19.44
LTE Band4	20	20300	100	#0	QAM16	18.76	19.60



Band	Bandwidth (MHz)	UL Channel	RB Size	RB Position	Modulation	Power (dBm)	EIRP
LTE Band7	5	20775	1	#0	QPSK	21.17	22.50
LTE Band7	5	20775	1	#Mid	QPSK	21.14	22.47
LTE Band7	5	20775	1	#Max	QPSK	21.07	22.40
LTE Band7	5	20775	12	#0	QPSK	20.40	21.73
LTE Band7	5	20775	12	#Mid	QPSK	20.41	21.74
LTE Band7	5	20775	12	#Max	QPSK	20.17	21.50
LTE Band7	5	20775	25	#0	QPSK	20.35	21.68
LTE Band7	5	20775	1	#0	QAM16	20.62	21.95
LTE Band7	5	20775	1	#Mid	QAM16	20.17	21.50
LTE Band7	5	20775	1	#Max	QAM16	20.37	21.70
LTE Band7	5	20775	12	#0	QAM16	19.19	20.52
LTE Band7	5	20775	12	#Mid	QAM16	19.22	20.55
LTE Band7	5	20775	12	#Max	QAM16	18.94	20.27
LTE Band7	5	20775	25	#0	QAM16	19.43	20.76
LTE Band7	5	21100	1	#0	QPSK	21.21	22.54
LTE Band7	5	21100	1	#Mid	QPSK	21.27	22.60
LTE Band7	5	21100	1	#Max	QPSK	21.31	22.64
LTE Band7	5	21100	12	#0	QPSK	20.31	21.64
LTE Band7	5	21100	12	#Mid	QPSK	20.21	21.54
LTE Band7	5	21100	12	#Max	QPSK	20.23	21.56
LTE Band7	5	21100	25	#0	QPSK	20.37	21.70
LTE Band7	5	21100	1	#0	QAM16	20.25	21.58
LTE Band7	5	21100	1	#Mid	QAM16	19.88	21.21
LTE Band7	5	21100	1	#Max	QAM16	19.80	21.13
LTE Band7	5	21100	12	#0	QAM16	19.44	20.77
LTE Band7	5	21100	12	#Mid	QAM16	19.40	20.73
LTE Band7	5	21100	12	#Max	QAM16	19.38	20.71
LTE Band7	5	21100	25	#0	QAM16	19.28	20.61
LTE Band7	5	21425	1	#0	QPSK	21.16	22.49
LTE Band7	5	21425	1	#Mid	QPSK	21.28	22.61
LTE Band7	5	21425	1	#Max	QPSK	21.31	22.64
LTE Band7	5	21425	12	#0	QPSK	20.42	21.75
LTE Band7	5	21425	12	#Mid	QPSK	20.39	21.72
LTE Band7	5	21425	12	#Max	QPSK	20.29	21.62
LTE Band7	5	21425	25	#0	QPSK	20.39	21.72
LTE Band7	5	21425	1	#0	QAM16	20.18	21.51
LTE Band7	5	21425	1	#Mid	QAM16	19.99	21.32
LTE Band7	5	21425	1	#Max	QAM16	19.99	21.32
LTE Band7	5	21425	12	#0	QAM16	19.52	20.85
LTE Band7	5	21425	12	#Mid	QAM16	19.50	20.83



LTE Band7	5	21425	12	#Max	QAM16	19.34	20.67
LTE Band7	5	21425	25	#0	QAM16	19.68	21.01
LTE Band7	10	20800	1	#0	QPSK	21.64	22.97
LTE Band7	10	20800	1	#Mid	QPSK	20.92	22.25
LTE Band7	10	20800	1	#Max	QPSK	21.04	22.37
LTE Band7	10	20800	25	#0	QPSK	20.22	21.55
LTE Band7	10	20800	25	#Mid	QPSK	20.15	21.48
LTE Band7	10	20800	25	#Max	QPSK	20.06	21.39
LTE Band7	10	20800	50	#0	QPSK	20.12	21.45
LTE Band7	10	20800	1	#0	QAM16	20.81	22.14
LTE Band7	10	20800	1	#Mid	QAM16	20.19	21.52
LTE Band7	10	20800	1	#Max	QAM16	20.10	21.43
LTE Band7	10	20800	25	#0	QAM16	19.23	20.56
LTE Band7	10	20800	25	#Mid	QAM16	19.24	20.57
LTE Band7	10	20800	25	#Max	QAM16	19.18	20.51
LTE Band7	10	20800	50	#0	QAM16	19.03	20.36
LTE Band7	10	21100	1	#0	QPSK	21.46	22.79
LTE Band7	10	21100	1	#Mid	QPSK	21.15	22.48
LTE Band7	10	21100	1	#Max	QPSK	21.17	22.50
LTE Band7	10	21100	25	#0	QPSK	20.15	21.48
LTE Band7	10	21100	25	#Mid	QPSK	20.19	21.52
LTE Band7	10	21100	25	#Max	QPSK	20.18	21.51
LTE Band7	10	21100	50	#0	QPSK	20.24	21.57
LTE Band7	10	21100	1	#0	QAM16	20.79	22.12
LTE Band7	10	21100	1	#Mid	QAM16	20.75	22.08
LTE Band7	10	21100	1	#Max	QAM16	20.48	21.81
LTE Band7	10	21100	25	#0	QAM16	19.35	20.68
LTE Band7	10	21100	25	#Mid	QAM16	19.41	20.74
LTE Band7	10	21100	25	#Max	QAM16	19.08	20.41
LTE Band7	10	21100	50	#0	QAM16	19.33	20.66
LTE Band7	10	21400	1	#0	QPSK	21.57	22.90
LTE Band7	10	21400	1	#Mid	QPSK	21.18	22.51
LTE Band7	10	21400	1	#Max	QPSK	21.34	22.67
LTE Band7	10	21400	25	#0	QPSK	20.24	21.57
LTE Band7	10	21400	25	#Mid	QPSK	20.40	21.73
LTE Band7	10	21400	25	#Max	QPSK	20.30	21.63
LTE Band7	10	21400	50	#0	QPSK	20.45	21.78
LTE Band7	10	21400	1	#0	QAM16	20.43	21.76
LTE Band7	10	21400	1	#Mid	QAM16	19.76	21.09
LTE Band7	10	21400	1	#Max	QAM16	20.33	21.66
LTE Band7	10	21400	25	#0	QAM16	19.32	20.65
LTE Band7	10	21400	25	#Mid	QAM16	19.34	20.67
LTE Band7	10	21400	25	#Max	QAM16	19.29	20.62



LTE Band7	10	21400	50	#0	QAM16	19.46	20.79
LTE Band7	15	20825	1	#0	QPSK	21.23	22.56
LTE Band7	15	20825	1	#Mid	QPSK	20.83	22.16
LTE Band7	15	20825	1	#Max	QPSK	21.14	22.47
LTE Band7	15	20825	36	#0	QPSK	20.03	21.36
LTE Band7	15	20825	36	#Mid	QPSK	20.02	21.35
LTE Band7	15	20825	36	#Max	QPSK	20.07	21.40
LTE Band7	15	20825	75	#0	QPSK	19.95	21.28
LTE Band7	15	20825	1	#0	QAM16	20.01	21.34
LTE Band7	15	20825	1	#Mid	QAM16	19.84	21.17
LTE Band7	15	20825	1	#Max	QAM16	20.00	21.33
LTE Band7	15	20825	36	#0	QAM16	18.87	20.20
LTE Band7	15	20825	36	#Mid	QAM16	18.87	20.20
LTE Band7	15	20825	36	#Max	QAM16	19.12	20.45
LTE Band7	15	20825	75	#0	QAM16	18.95	20.28
LTE Band7	15	21100	1	#0	QPSK	21.33	22.66
LTE Band7	15	21100	1	#Mid	QPSK	21.03	22.36
LTE Band7	15	21100	1	#Max	QPSK	21.13	22.46
LTE Band7	15	21100	36	#0	QPSK	20.07	21.40
LTE Band7	15	21100	36	#Mid	QPSK	20.11	21.44
LTE Band7	15	21100	36	#Max	QPSK	20.08	21.41
LTE Band7	15	21100	75	#0	QPSK	20.16	21.49
LTE Band7	15	21100	1	#0	QAM16	20.67	22.00
LTE Band7	15	21100	1	#Mid	QAM16	20.48	21.81
LTE Band7	15	21100	1	#Max	QAM16	20.59	21.92
LTE Band7	15	21100	36	#0	QAM16	19.32	20.65
LTE Band7	15	21100	36	#Mid	QAM16	19.20	20.53
LTE Band7	15	21100	36	#Max	QAM16	19.00	20.33
LTE Band7	15	21100	75	#0	QAM16	19.35	20.68
LTE Band7	15	21375	1	#0	QPSK	20.99	22.32
LTE Band7	15	21375	1	#Mid	QPSK	21.31	22.64
LTE Band7	15	21375	1	#Max	QPSK	21.23	22.56
LTE Band7	15	21375	36	#0	QPSK	20.22	21.55
LTE Band7	15	21375	36	#Mid	QPSK	20.27	21.60
LTE Band7	15	21375	36	#Max	QPSK	20.20	21.53
LTE Band7	15	21375	75	#0	QPSK	20.25	21.58
LTE Band7	15	21375	1	#0	QAM16	19.81	21.14
LTE Band7	15	21375	1	#Mid	QAM16	19.75	21.08
LTE Band7	15	21375	1	#Max	QAM16	19.66	20.99
LTE Band7	15	21375	36	#0	QAM16	19.16	20.49
LTE Band7	15	21375	36	#Mid	QAM16	19.15	20.48
LTE Band7	15	21375	36	#Max	QAM16	19.34	20.67
LTE Band7	15	21375	75	#0	QAM16	19.43	20.76



LTE Band7	20	20850	1	#0	QPSK	21.00	22.33
LTE Band7	20	20850	1	#Mid	QPSK	20.75	22.08
LTE Band7	20	20850	1	#Max	QPSK	20.92	22.25
LTE Band7	20	20850	50	#0	QPSK	19.91	21.24
LTE Band7	20	20850	50	#Mid	QPSK	19.88	21.21
LTE Band7	20	20850	50	#Max	QPSK	19.86	21.19
LTE Band7	20	20850	100	#0	QPSK	19.83	21.16
LTE Band7	20	20850	1	#0	QAM16	20.19	21.52
LTE Band7	20	20850	1	#Mid	QAM16	20.50	21.83
LTE Band7	20	20850	1	#Max	QAM16	20.44	21.77
LTE Band7	20	20850	50	#0	QAM16	18.84	20.17
LTE Band7	20	20850	50	#Mid	QAM16	18.82	20.15
LTE Band7	20	20850	50	#Max	QAM16	18.88	20.21
LTE Band7	20	20850	100	#0	QAM16	18.96	20.29
LTE Band7	20	21100	1	#0	QPSK	21.24	22.57
LTE Band7	20	21100	1	#Mid	QPSK	21.22	22.55
LTE Band7	20	21100	1	#Max	QPSK	21.06	22.39
LTE Band7	20	21100	50	#0	QPSK	20.07	21.40
LTE Band7	20	21100	50	#Mid	QPSK	20.01	21.34
LTE Band7	20	21100	50	#Max	QPSK	20.01	21.34
LTE Band7	20	21100	100	#0	QPSK	20.09	21.42
LTE Band7	20	21100	1	#0	QAM16	19.78	21.11
LTE Band7	20	21100	1	#Mid	QAM16	19.14	20.47
LTE Band7	20	21100	1	#Max	QAM16	19.71	21.04
LTE Band7	20	21100	50	#0	QAM16	19.16	20.49
LTE Band7	20	21100	50	#Mid	QAM16	19.17	20.50
LTE Band7	20	21100	50	#Max	QAM16	18.92	20.25
LTE Band7	20	21100	100	#0	QAM16	19.17	20.50
LTE Band7	20	21350	1	#0	QPSK	21.38	22.71
LTE Band7	20	21350	1	#Mid	QPSK	21.37	22.70
LTE Band7	20	21350	1	#Max	QPSK	21.05	22.38
LTE Band7	20	21350	50	#0	QPSK	20.05	21.38
LTE Band7	20	21350	50	#Mid	QPSK	20.19	21.52
LTE Band7	20	21350	50	#Max	QPSK	20.15	21.48
LTE Band7	20	21350	100	#0	QPSK	20.22	21.55
LTE Band7	20	21350	1	#0	QAM16	20.35	21.68
LTE Band7	20	21350	1	#Mid	QAM16	20.55	21.88
LTE Band7	20	21350	1	#Max	QAM16	20.22	21.55
LTE Band7	20	21350	50	#0	QAM16	19.00	20.33
LTE Band7	20	21350	50	#Mid	QAM16	19.06	20.39
LTE Band7	20	21350	50	#Max	QAM16	19.22	20.55
LTE Band7	20	21350	100	#0	QAM16	19.17	20.50

5.2 Occupied Bandwidth

Ambient condition

Temperature	Relative humidity	Pressure
23°C ~25°C	45%~50%	101.5kPa

Method of Measurement

The EUT was connected to Spectrum Analyzer and Base Station Simulator via power Splitter. The occupied bandwidth is measured using spectrum analyzer.

RBW is set to 30 kHz, VBW is set to 91kHz for LTE Band 4 (1.4MHz).

RBW is set to 62 kHz, VBW is set to 180kHz for LTE Band 4 (3MHz).

RBW is set to 100 kHz, VBW is set to 300 kHz for LTE Band 4/7 (5MHz).

RBW is set to 200 kHz, VBW is set to 620kHz for LTE Band 4/7 (10MHz).

RBW is set to 300 kHz, VBW is set to 910kHz for LTE Band 4/7 (15MHz).

RBW is set to 430 kHz, VBW is set to 1.2MHz for LTE Band 4/7 (20MHz).

99% power and -26dBc occupied bandwidths are recorded. Spectrum analyzer plots are included on the following pages.

Test Setup

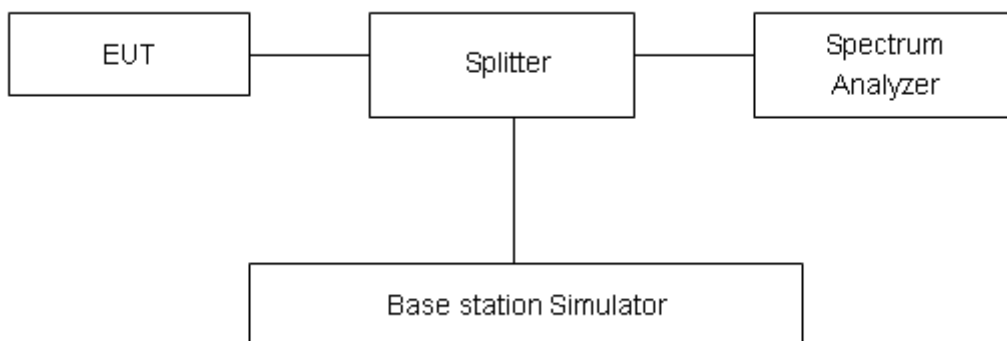

Limits

No specific occupied bandwidth requirements in part 2.1049.

Measurement Uncertainty

The assessed measurement uncertainty to ensure 95% confidence level for the normal distribution is with the coverage factor $k = 2$, $U=624\text{Hz}$.



Test Result

LTE Band 4						
RB	Modulation	Bandwidth (MHz)	Channel	Frequency (MHz)	99% Power Bandwidth(MHz)	-26dBc Bandwidth(MHz)
100%	QPSK	1.4	19957	1710.7	1.0920	1.285
			20175	1732.5	1.1014	1.266
			20393	1754.3	1.1064	1.274
		3	19965	1711.5	2.7091	2.982
			20175	1732.5	2.6990	2.991
			20385	1753.5	2.7003	2.977
		5	19975	1712.5	4.5247	4.918
			20175	1732.5	4.5186	4.965
			20375	1752.5	4.5164	4.951
		10	20000	1715	8.9754	9.718
			20175	1732.5	8.9677	9.792
			20350	1750	8.9509	9.788
		15	20025	1717.5	13.4190	14.560
			20175	1732.5	13.4130	14.510
			20325	1747.5	13.4000	14.530
		20	20050	1720	17.8970	19.320
			20175	1732.5	17.9380	19.310
			20300	1745	17.7870	19.310
	16QAM	1.4	19957	1710.7	1.0898	1.302
			20175	1732.5	1.0915	1.271
			20393	1754.3	1.0926	1.292
		3	19965	1711.5	2.6918	2.962
			20175	1732.5	2.7085	3.006
			20385	1753.5	2.7037	2.966
		5	19975	1712.5	4.5085	4.953
			20175	1732.5	4.5150	5.005
			20375	1752.5	4.5175	5.026
		10	20000	1715	8.9509	9.797
			20175	1732.5	9.0034	9.752
			20350	1750	8.9671	9.784
15		20025	1717.5	13.4330	14.550	
		20175	1732.5	13.4410	14.410	
		20325	1747.5	13.3950	14.540	
20		20050	1720	17.9140	19.410	
		20175	1732.5	17.9370	19.340	
		20300	1745	17.8130	19.280	



LTE Band 7						
RB	Modulation	Bandwidth (MHz)	Channel	Frequency (MHz)	99% Power Bandwidth(MHz)	-26dBc Bandwidth(MHz)
100%	QPSK	5	20775	2502.5	4.5049	4.994
			21100	2535	4.5064	5.023
			21425	2567.5	4.5099	4.946
		10	20800	2505	8.9733	9.858
			21100	2535	8.9575	9.744
			21400	2565	8.9736	9.820
		15	20825	2507.5	13.4710	14.780
			21100	2535	13.4310	14.490
			21375	2562.5	13.4050	14.550
		20	20850	2510	17.9580	19.380
			21100	2535	17.8870	19.490
			21350	2560	17.7690	19.160
	16QAM	5	20775	2502.5	4.5042	4.981
			21100	2535	4.5128	4.941
			21425	2567.5	4.5027	4.969
		10	20800	2505	8.9987	9.733
			21100	2535	8.9861	9.714
			21400	2565	8.9603	9.814
		15	20825	2507.5	13.5070	14.500
			21100	2535	13.4460	14.460
			21375	2562.5	13.4490	14.500
		20	20850	2510	17.9500	19.410
			21100	2535	17.8990	19.590
			21350	2560	17.8610	19.370



LTE Band 4 QPSK 1.4MHz CH-Low

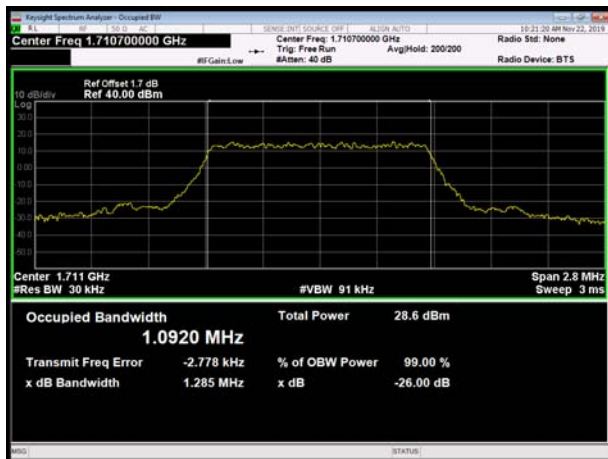

LTE Band 4 QPSK 3MHz CH-Low

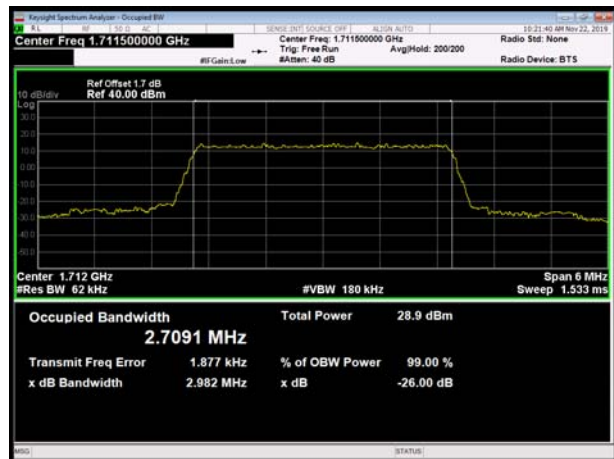

LTE Band 4 QPSK 1.4MHz CH-Middle

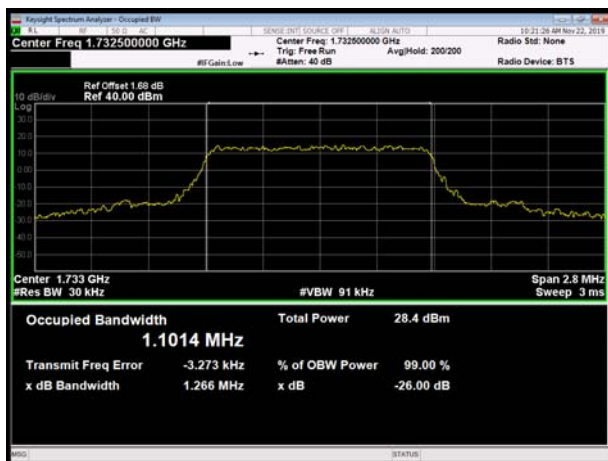

LTE Band 4 QPSK 3MHz CH-Middle

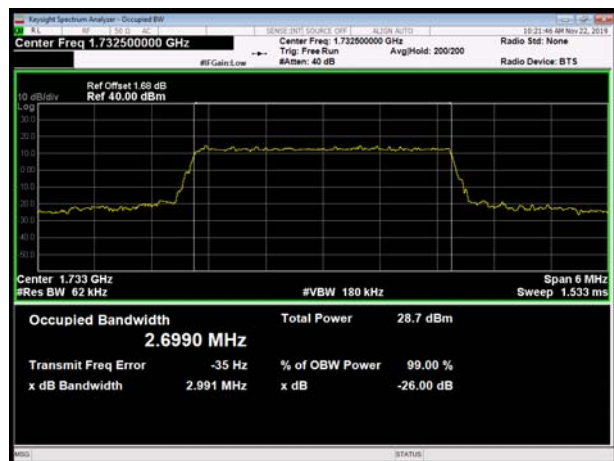

LTE Band 4 QPSK 1.4MHz CH-High

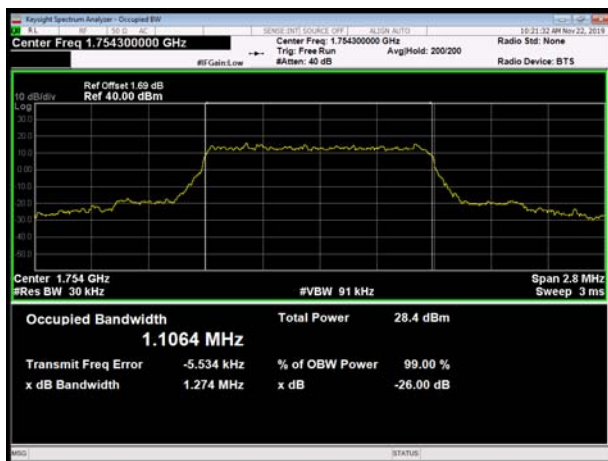

LTE Band 4 QPSK 3MHz CH-High

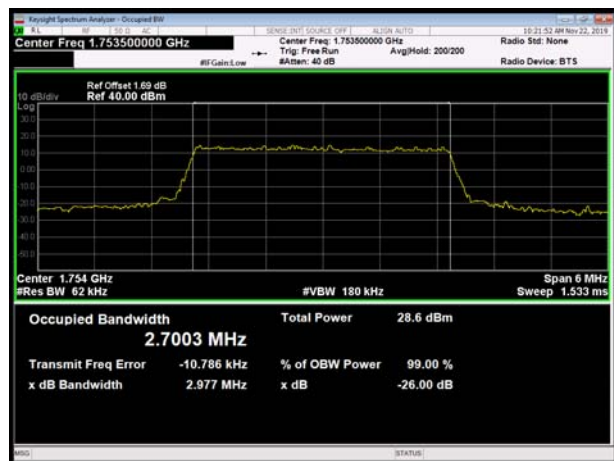



LTE Band 4 QPSK 5MHz CH-Low



LTE Band 4 QPSK 10MHz CH-Low



LTE Band 4 QPSK 5MHz CH-Middle

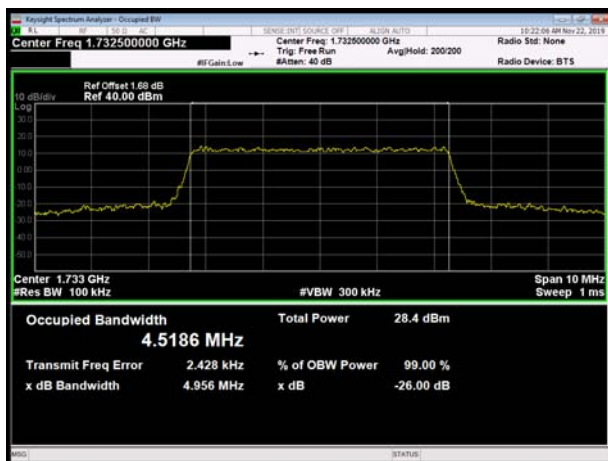

LTE Band 4 QPSK 10MHz CH-Middle

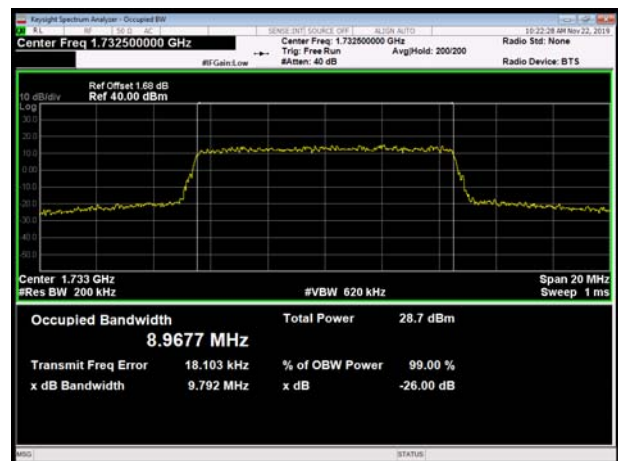

LTE Band 4 QPSK 5MHz CH-High

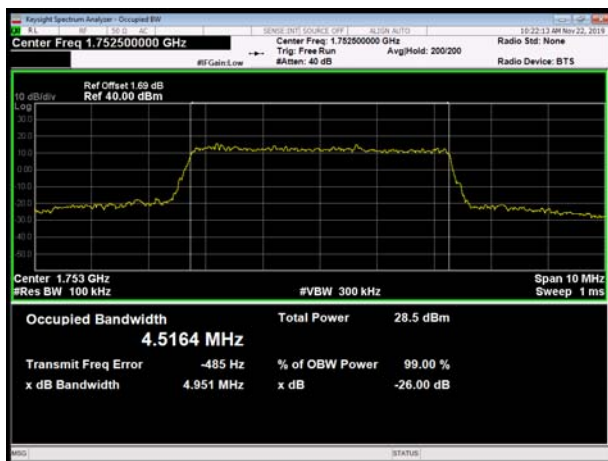

LTE Band 4 QPSK 10MHz CH-High





LTE Band 4 QPSK 15MHz CH-Low

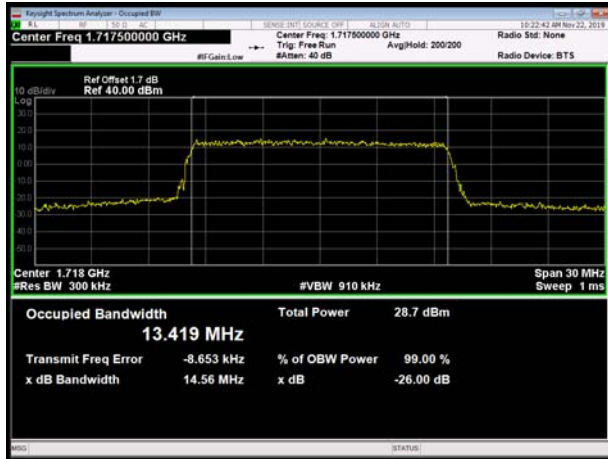

LTE Band 4 QPSK 20MHz CH-Low

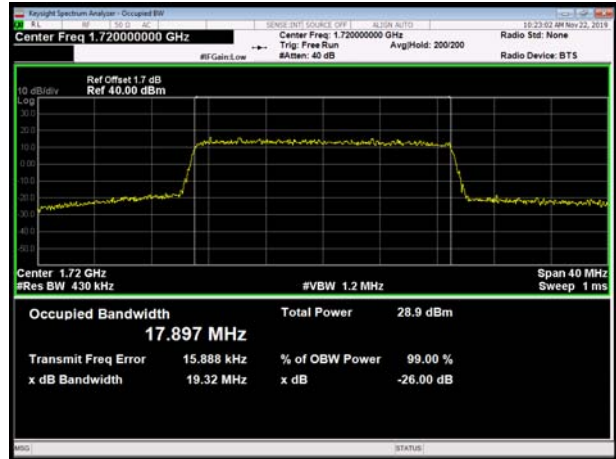

LTE Band 4 QPSK 15MHz CH-Middle



LTE Band 4 QPSK 20MHz CH-Middle

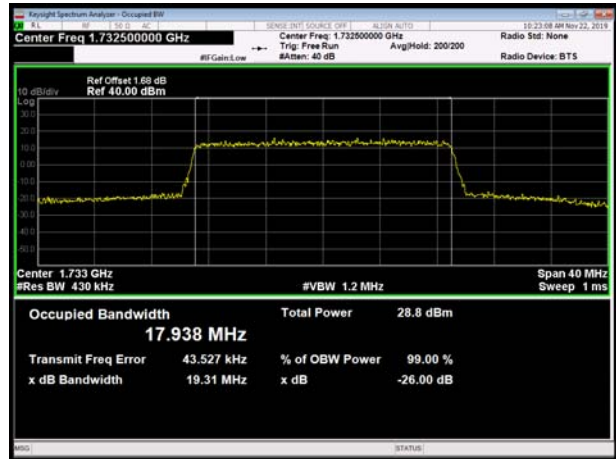

LTE Band 4 QPSK 15MHz CH-High



LTE Band 4 QPSK 20MHz CH-High

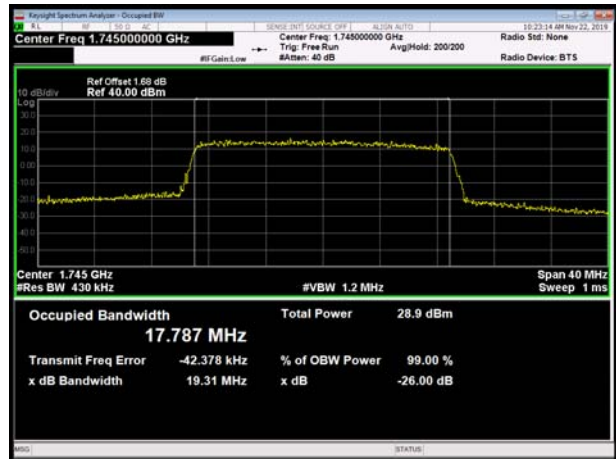



LTE Band 4 16QAM 1.4MHz CH-Low

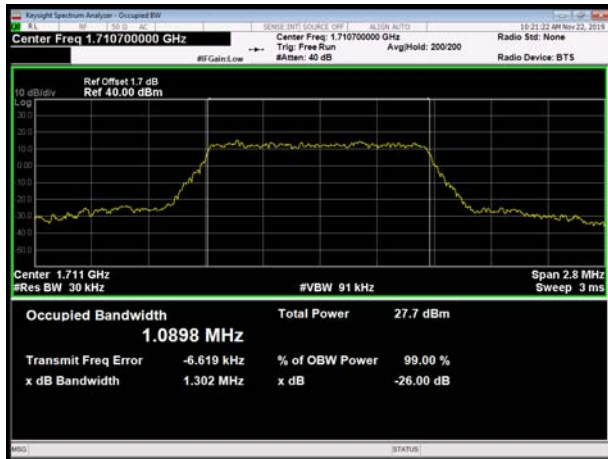

LTE Band 4 16QAM 3MHz CH-Low

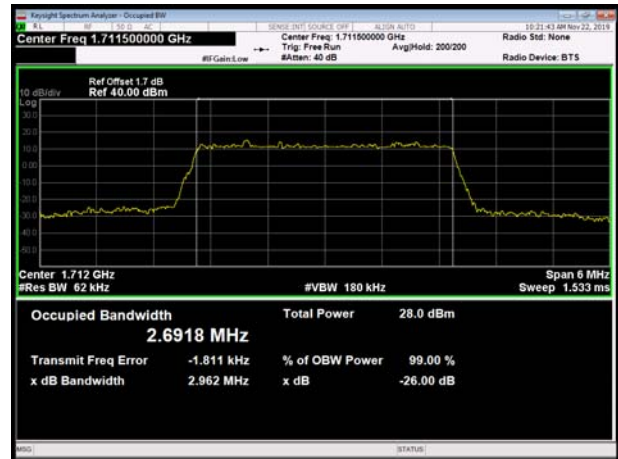

LTE Band 4 16QAM 1.4MHz CH-Middle

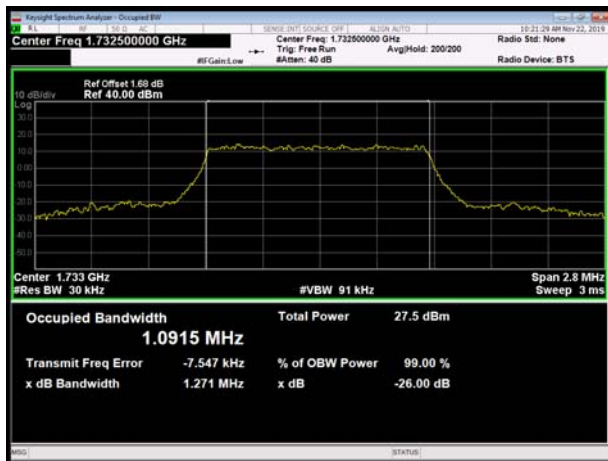

LTE Band 4 16QAM 3MHz CH-Middle



LTE Band 4 16QAM 1.4MHz CH-High

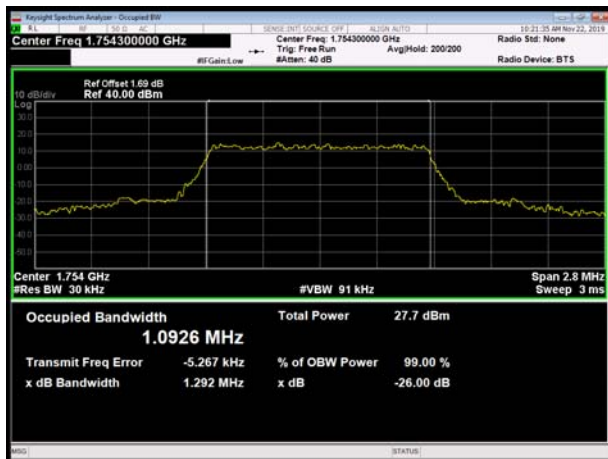

LTE Band 4 16QAM 3MHz CH-High

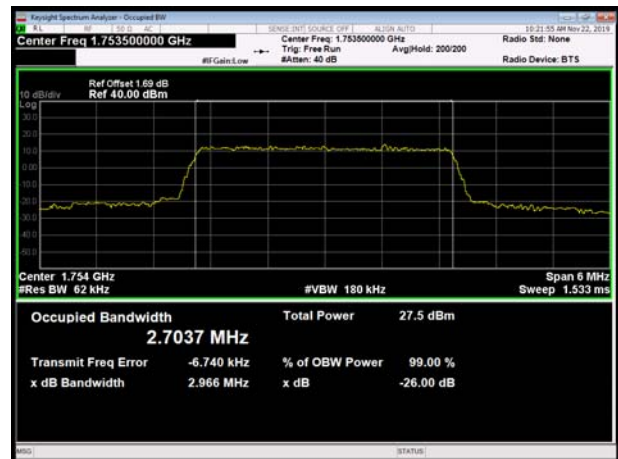



LTE Band 4 16QAM 5MHz CH-Low

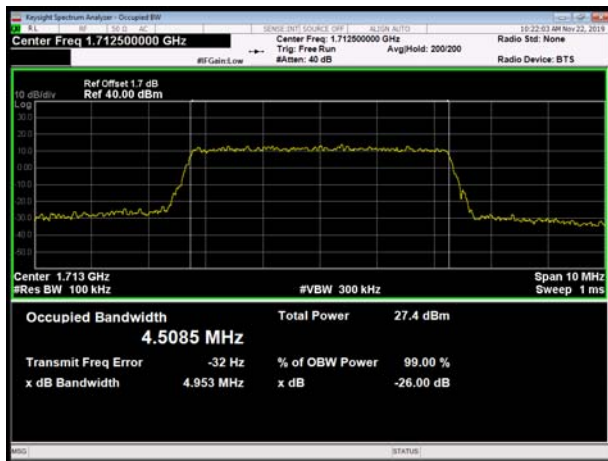

LTE Band 4 16QAM 10MHz CH-Low

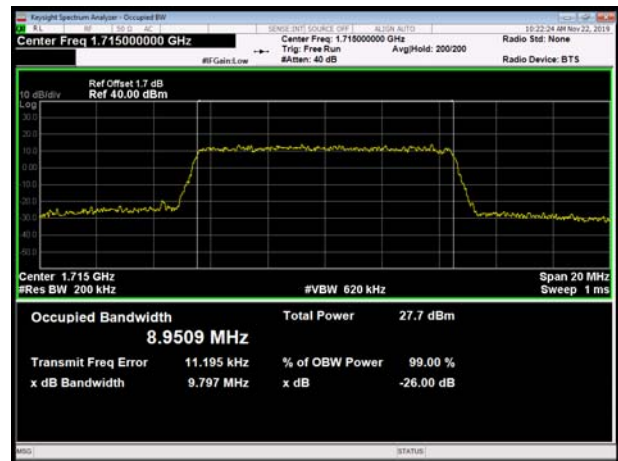

LTE Band 4 16QAM 5MHz CH-Middle

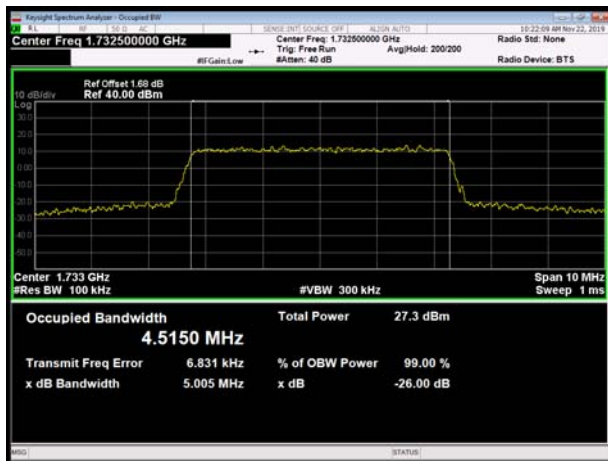

LTE Band 4 16QAM 10MHz CH-Middle

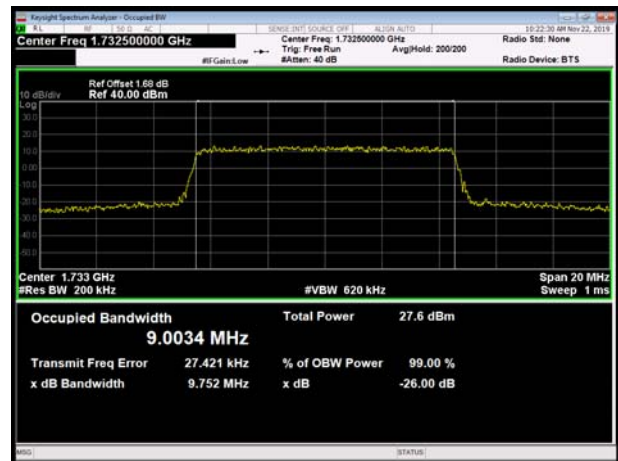

LTE Band 4 16QAM 5MHz CH-High

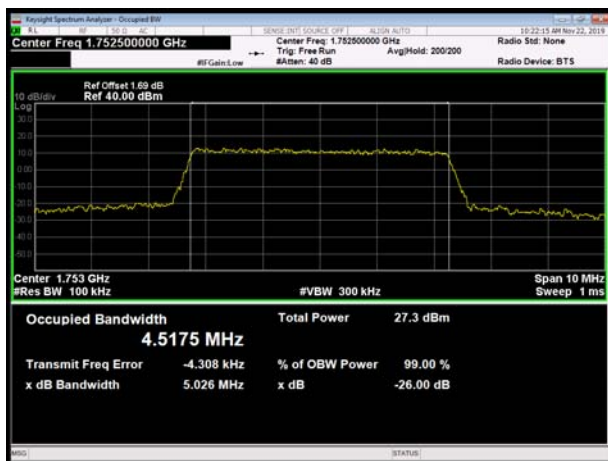

LTE Band 4 16QAM 10MHz CH-High





LTE Band 4 16QAM 15MHz CH-Low

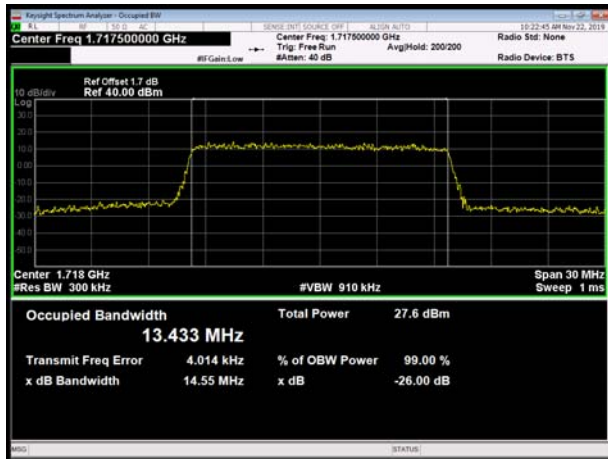

LTE Band 4 16QAM 20MHz CH-Low



LTE Band 4 16QAM 15MHz CH-Middle

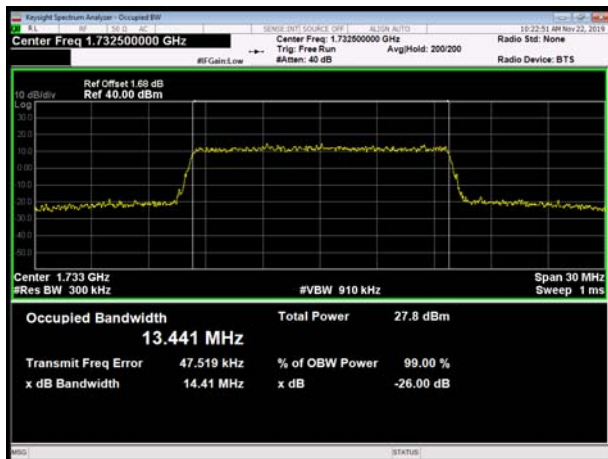

LTE Band 4 16QAM 20MHz CH-Middle

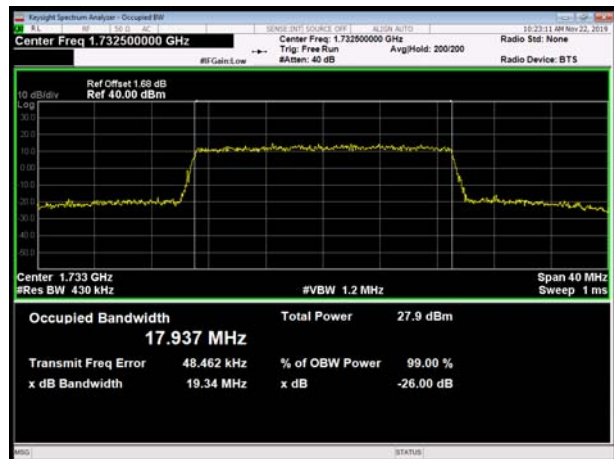

LTE Band 4 16QAM 15MHz CH-High

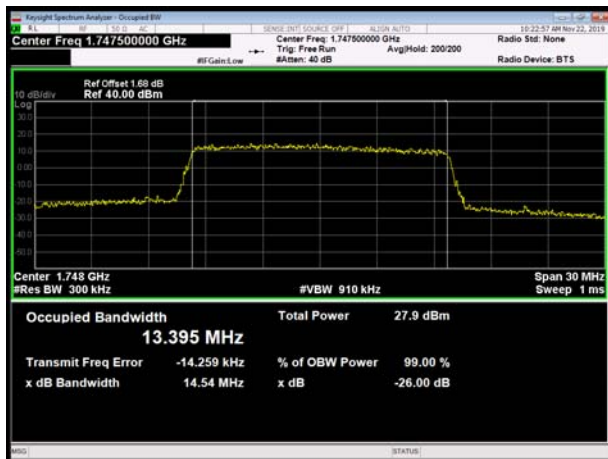

LTE Band 4 16QAM 20MHz CH-High





LTE Band 7 QPSK 5MHz CH-Low

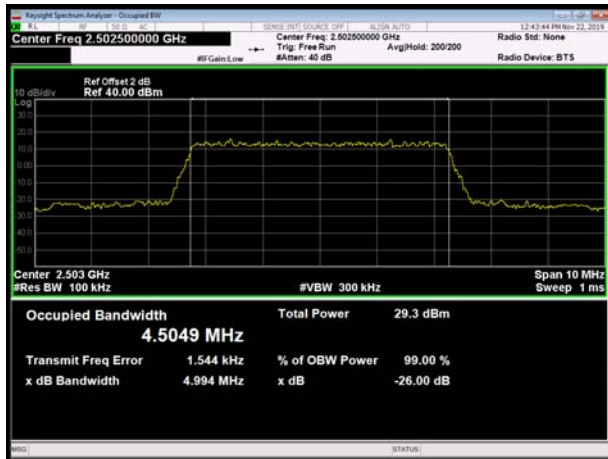

LTE Band 7 QPSK 10MHz CH-Low

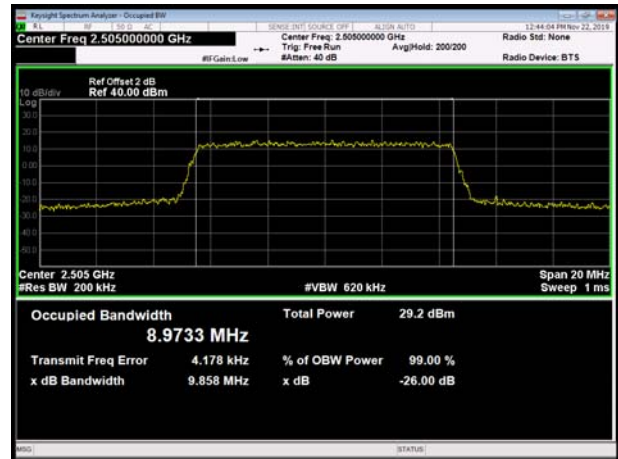

LTE Band 7 QPSK 5MHz CH-Middle

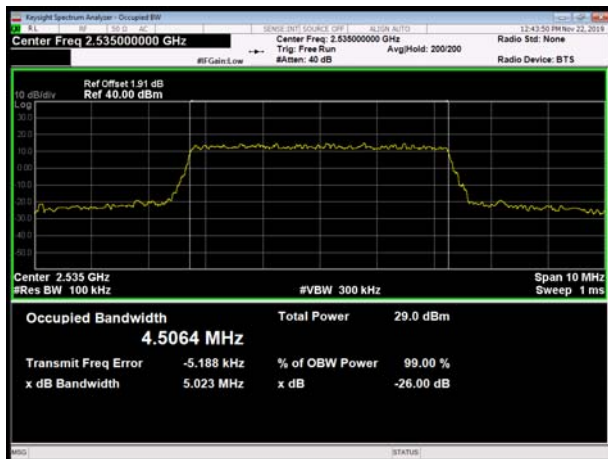

LTE Band 7 QPSK 10MHz CH-Middle

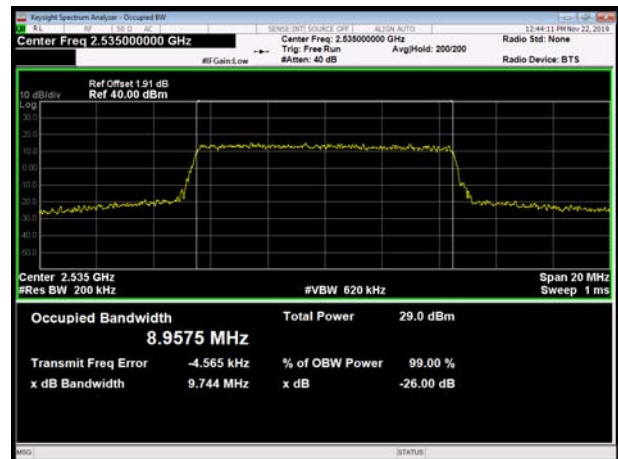

LTE Band 7 QPSK 5MHz CH-High



LTE Band 7 QPSK 10MHz CH-High

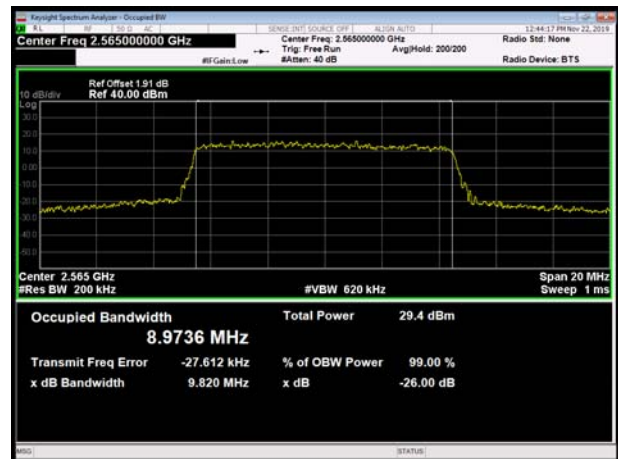



LTE Band 7 QPSK 15MHz CH-Low

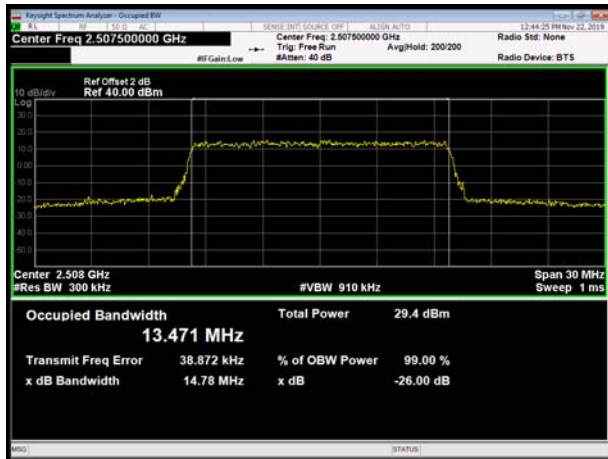

LTE Band 7 QPSK 20MHz CH-Low



LTE Band 7 QPSK 15MHz CH-Middle



LTE Band 7 QPSK 20MHz CH-Middle



LTE Band 7 QPSK 15MHz CH-High



LTE Band 7 QPSK 20MHz CH-High

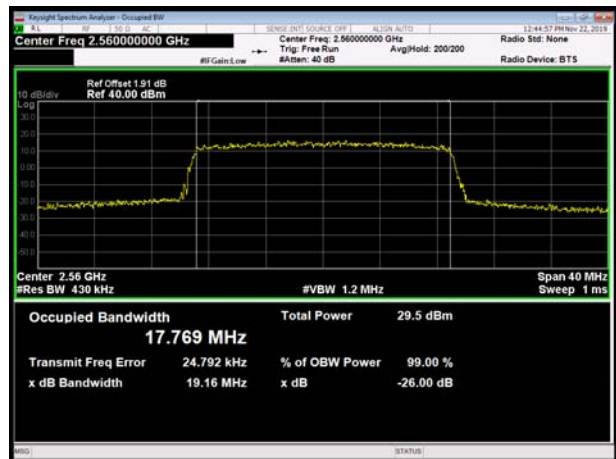

LTE Band 7 16QAM 5MHz CH-Low

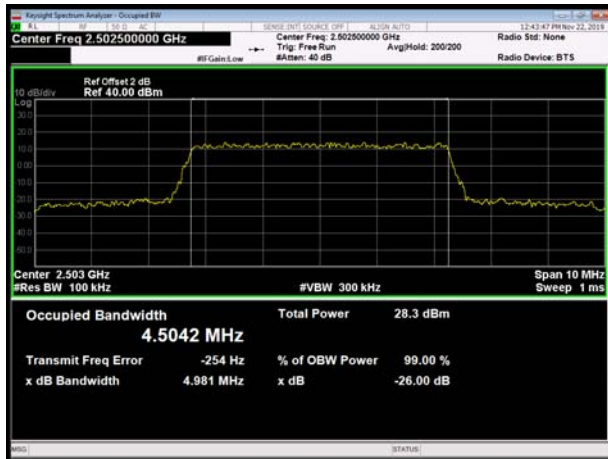

LTE Band 7 16QAM 10MHz CH-Low



LTE Band 7 16QAM 5MHz CH-Middle

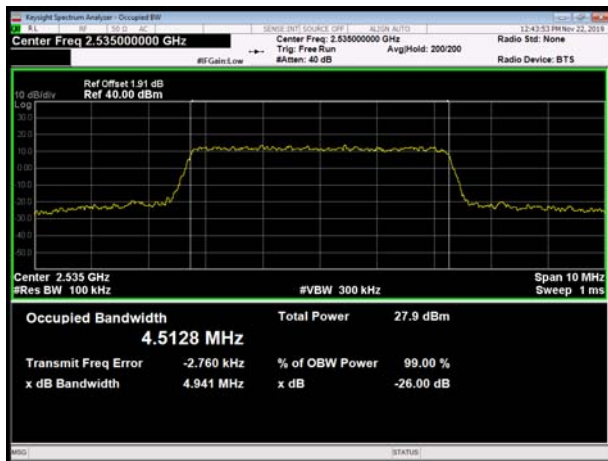

LTE Band 7 16QAM 10MHz CH-Middle



LTE Band 7 16QAM 5MHz CH-High

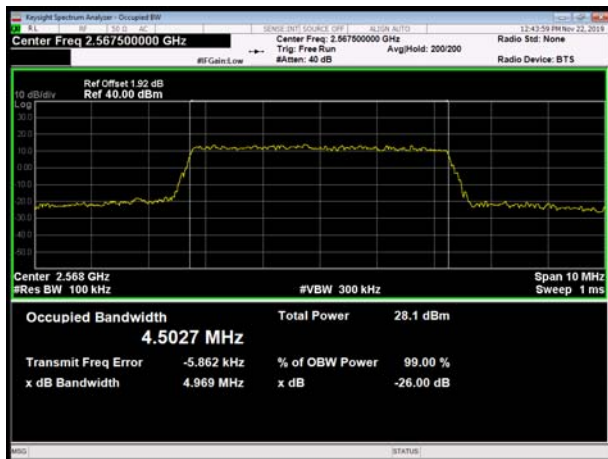

LTE Band 7 16QAM 10MHz CH-High

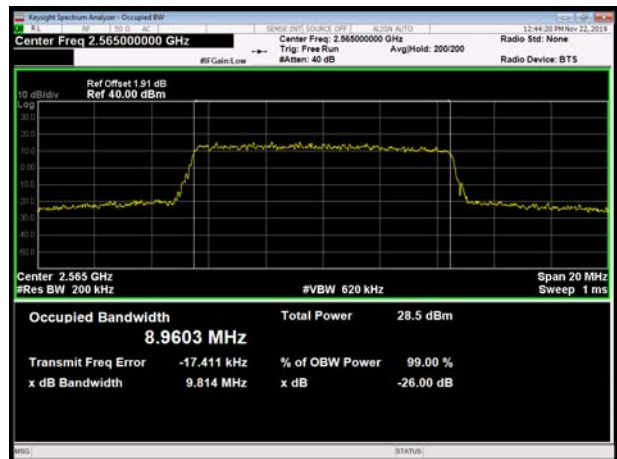



LTE Band 7 16QAM 15MHz CH-Low



LTE Band 7 16QAM 20MHz CH-Low



LTE Band 7 16QAM 15MHz CH-Middle

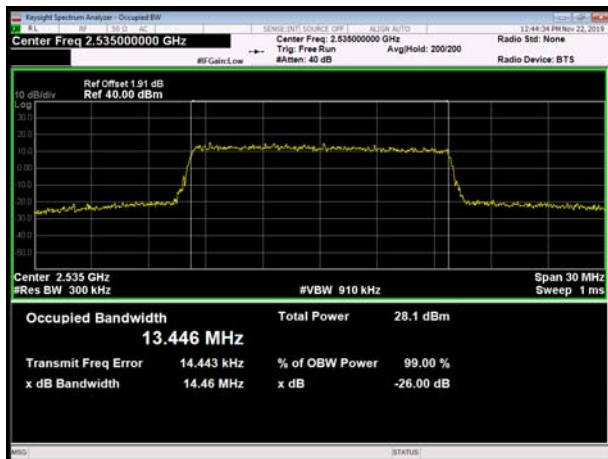

LTE Band 7 16QAM 20MHz CH-Middle

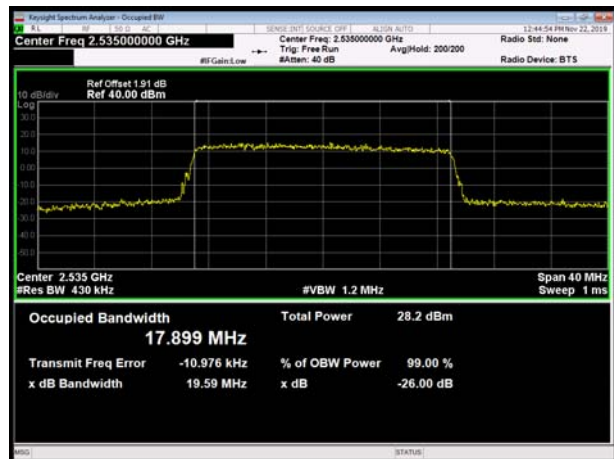

LTE Band 7 16QAM 15MHz CH-High



LTE Band 7 16QAM 20MHz CH-High

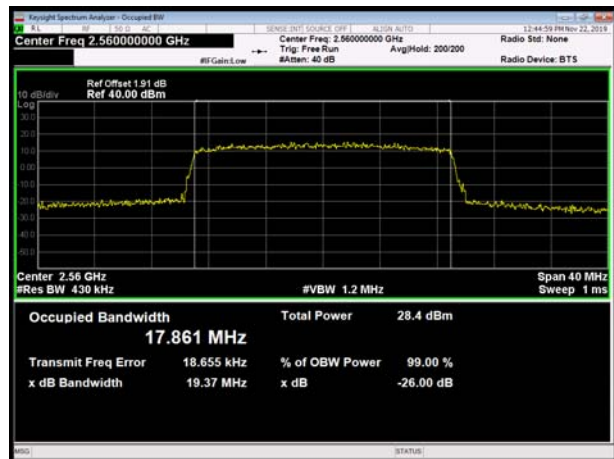

5.3 Band Edge Compliance

Ambient condition

Temperature	Relative humidity	Pressure
23°C ~25°C	45%~50%	101.5kPa

Method of Measurement

The EUT was connected to Spectrum Analyzer and Base Station Simulator via power Splitter. The band edge of the lowest and highest channels were measured.

The testing follows KDB 971168 D01 v03r01 Section 6.0

The EUT was connected to spectrum analyzer and system simulator via a power divider.

The band edges of low and high channels for the highest RF powers were measured.

RBW is set to 15kHz, VBW is set to 43kHz for LTE Band 4 (1.4MHz).

RBW is set to 30kHz,VBW is set to 91kHz for LTE Band 4 (3MHz).

RBW is set to 51kHz,VBW is set to 150kHz for LTE Band 4 (5MHz).

RBW is set to 100kHz,VBW is set to 300kHz for LTE Band 4 (10MHz).

RBW is set to 150kHz,VBW is set to 470kHz for LTE Band 4 (15MHz).

RBW is set to 200kHz,VBW is set to 620kHz for LTE Band 4 (20MHz)

RBW is set to 50kHz,VBW is set to 200kHz for LTE Band 7 (5MHz).

RBW is set to 100kHz,VBW is set to 300kHz for LTE Band 7 (10MHz).

RBW is set to 200kHz,VBW is set to 1MHz for LTE Band 7 (15MHz/20MHz).

on spectrum analyzer.

Set spectrum analyzer with RMS detector.

The RF fundamental frequency should be excluded against the limit line in the operating frequency band.

Checked that all the results comply with the emission limit line.

Test Setup

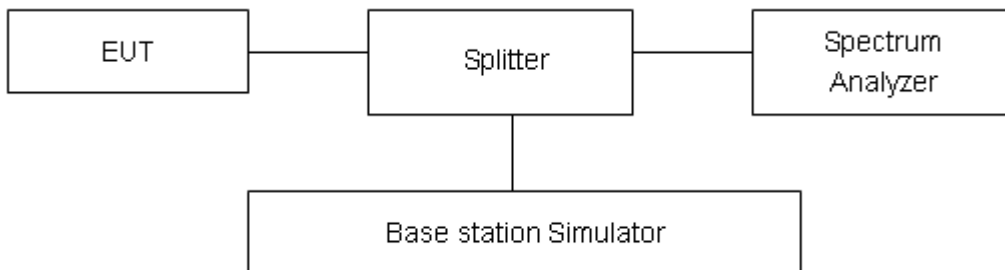

Limits

Rule Part 27.53(h) specifies that “ for operations in the 1695-1710 MHz, 1710-1755 MHz, 1755-1780



MHz, 1915-1920 MHz, 1995-2000 MHz, 2000-2020 MHz, 2110-2155 MHz, 2155-2180 MHz, and 2180-2200 bands, the power of any emission outside a licensee's frequency block shall be attenuated below the transmitter power (P) in watts by at least $43 + 10 \log_{10}(P)$ dB"

Rule Part 27.53(m) (4) specifies that "for BRS and EBS stations. For mobile digital stations, the attenuation factor shall be not less than $40 + 10 \log(P)$ dB on all frequencies between the channel edge and 5 megahertz from the channel edge, $43 + 10 \log(P)$ dB on all frequencies between 5 megahertz and X megahertz from the channel edge, and $55 + 10 \log(P)$ dB on all frequencies more than X megahertz from the channel edge, where X is the greater of 6 megahertz or the actual emission bandwidth as defined in paragraph (m)(4) of this section. In addition, the attenuation factor shall not be less that $43 + 10 \log(P)$ dB on all frequencies between 2490.5 MHz and 2496 MHz and $55 + 10 \log(P)$ dB at or below 2490.5 MHz. Mobile Satellite Service licensees operating on frequencies below 2495 MHz may also submit a documented interference complaint against BRS licensees operating on channel BRS Channel 1 on the same terms and conditions as adjacent channel BRS or EBS licensees.

Example:

The limit line is derived from $43 + 10 \log(P)$ dB below the transmitter power P(Watts)
= P(W)- $[43 + 10 \log(P)]$ (dB)
= $[30 + 10 \log(P)]$ (dBm) - $[43 + 10 \log(P)]$ (dB) = -13dBm.

Measurement Uncertainty

The assessed measurement uncertainty to ensure 95% confidence level for the normal distribution is with the coverage factor $k = 1.96$, $U=0.684$ dB.



Test Result

All the test traces in the plots shows the test results clearly.

LTE Band 4 QPSK 1.4MHz CH-Low, 1 RB



LTE Band 4 QPSK 1.4MHz CH-High, 1 RB



LTE Band 4 QPSK 1.4MHz CH-Low, 100%RB



LTE Band 4 QPSK 1.4MHz CH-High, 100%RB



LTE Band 4 QPSK 3MHz CH-Low, 1 RB

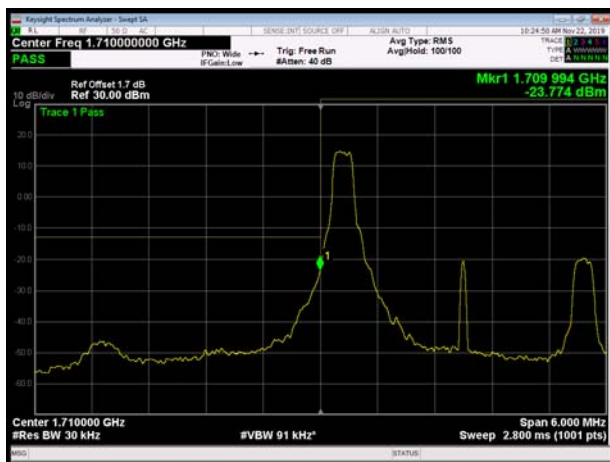

LTE Band 4 QPSK 3MHz CH-High, 1 RB

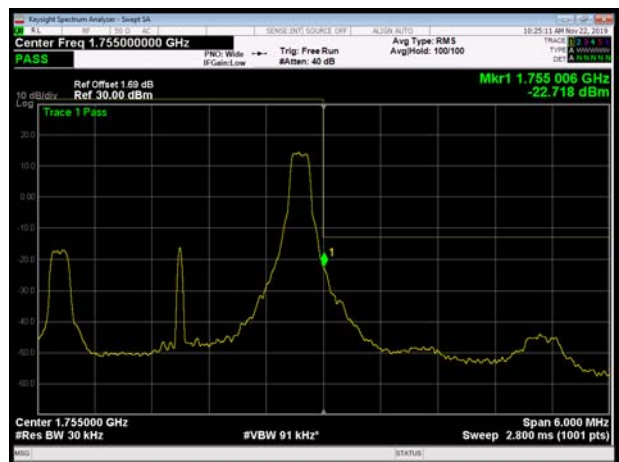



LTE Band 4 QPSK 3MHz CH-Low, 100%RB



LTE Band 4 QPSK 3MHz CH-High, 100%RB

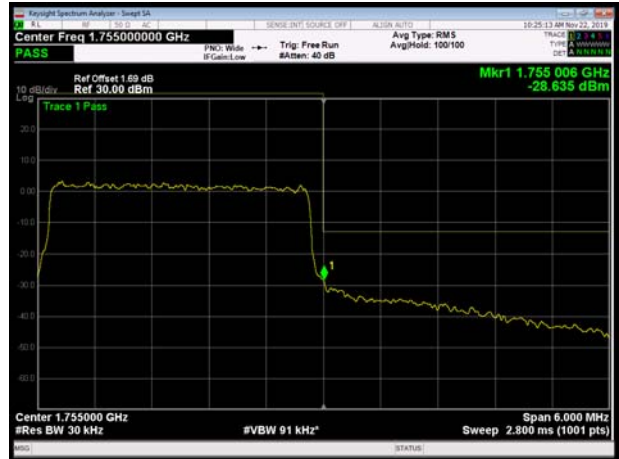

LTE Band 4 QPSK 5MHz CH-Low, 1 RB

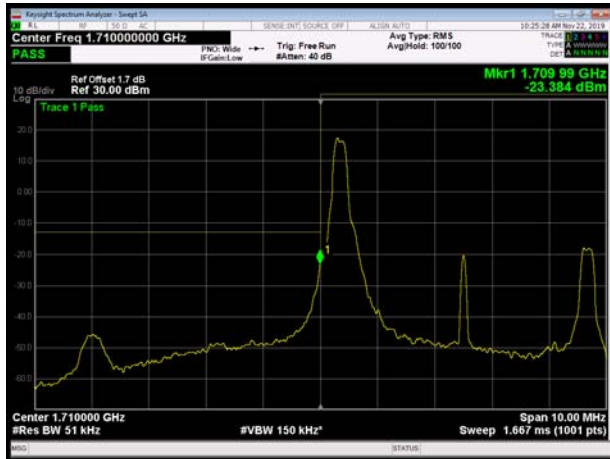

LTE Band 4 QPSK 5MHz CH-High, 1 RB

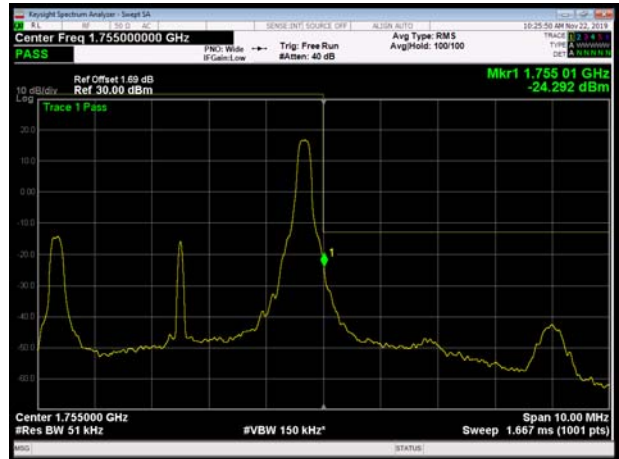

LTE Band 4 QPSK 5MHz CH-Low, 100%RB

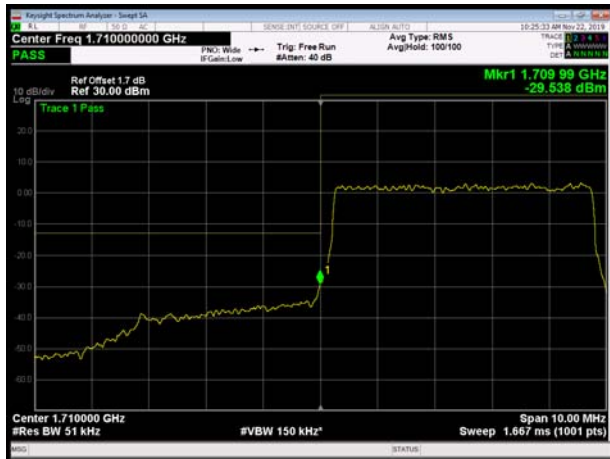

LTE Band 4 QPSK 5MHz CH-High, 100%RB





LTE Band 4 QPSK 10MHz CH-Low, 1 RB

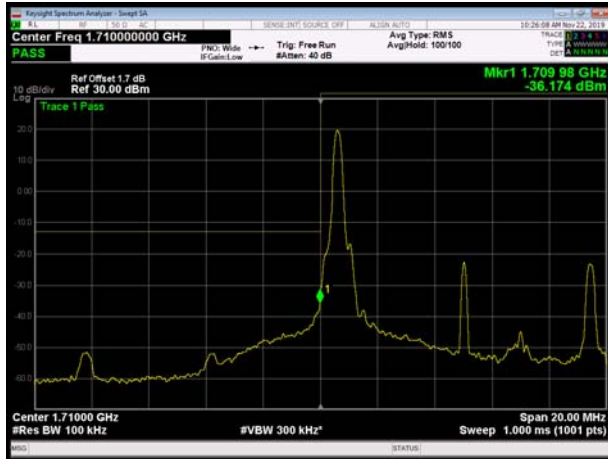

LTE Band 4 QPSK 10MHz CH-High, 1 RB

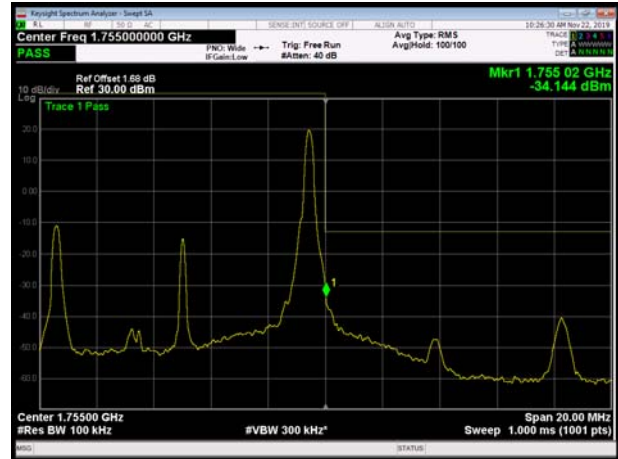

LTE Band 4 QPSK 10MHz CH-Low, 100%RB



LTE Band 4 QPSK 10MHz CH-High, 100%RB



LTE Band 4 QPSK 15MHz CH-Low, 1 RB

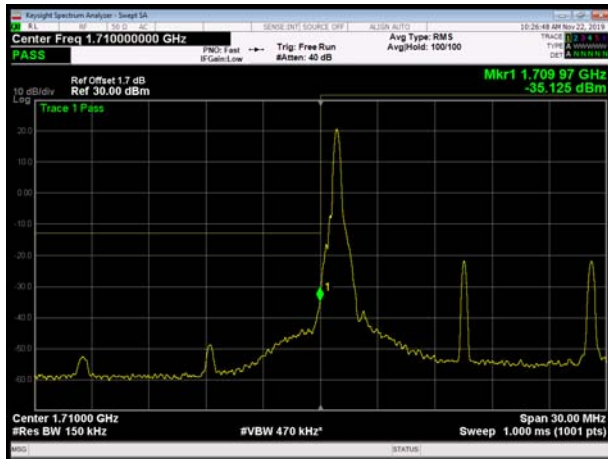

LTE Band 4 QPSK 15MHz CH-High, 1 RB

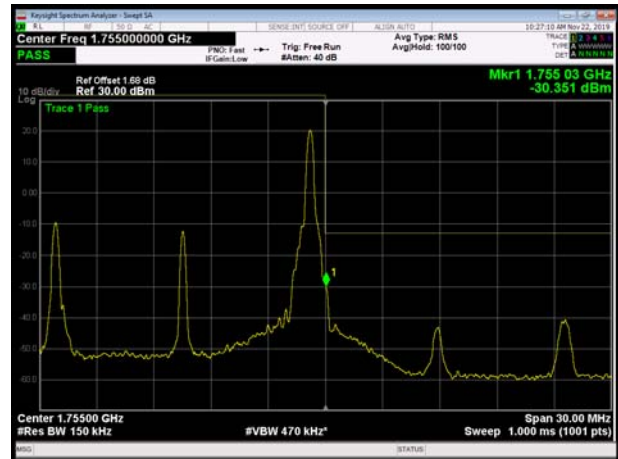



LTE Band 4 QPSK 15MHz CH-Low, 100%RB



LTE Band 4 QPSK 15MHz CH-High, 100%RB



LTE Band 4 QPSK 20MHz CH-Low, 1 RB

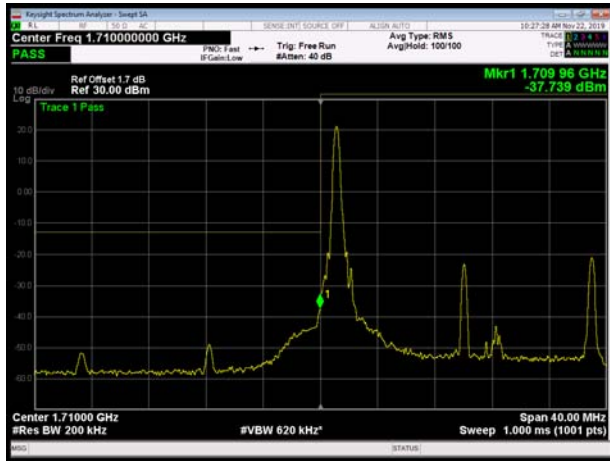

LTE Band 4 QPSK 20MHz CH-High, 1 RB

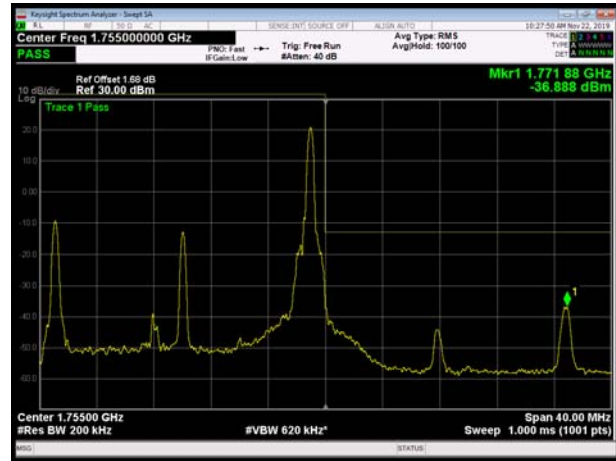

LTE Band 4 QPSK 20MHz CH-Low, 100%RB

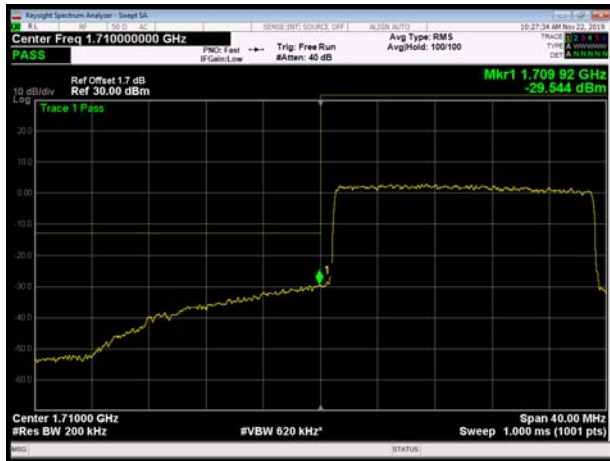

LTE Band 4 QPSK 20MHz CH-High, 100%RB





LTE Band 4 16QAM 1.4MHz CH-Low, 1 RB

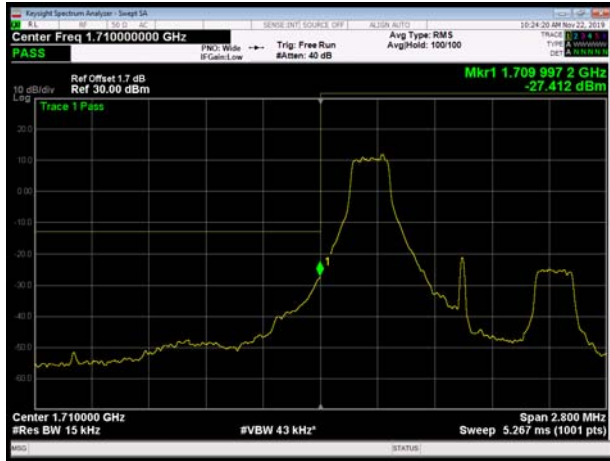

LTE Band 4 16QAM 1.4MHz CH-High, 1 RB



LTE Band 4 16QAM 1.4MHz CH-Low, 100%RB



LTE Band 4 16QAM 1.4MHz CH-High, 100%RB



LTE Band 4 16QAM 3MHz CH-Low, 1 RB

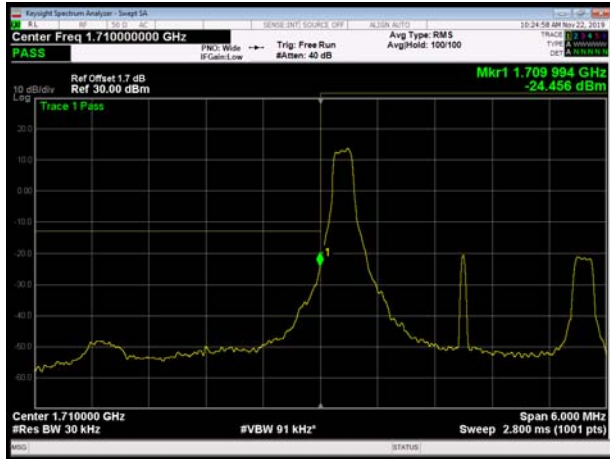

LTE Band 4 16QAM 3MHz CH-High, 1 RB

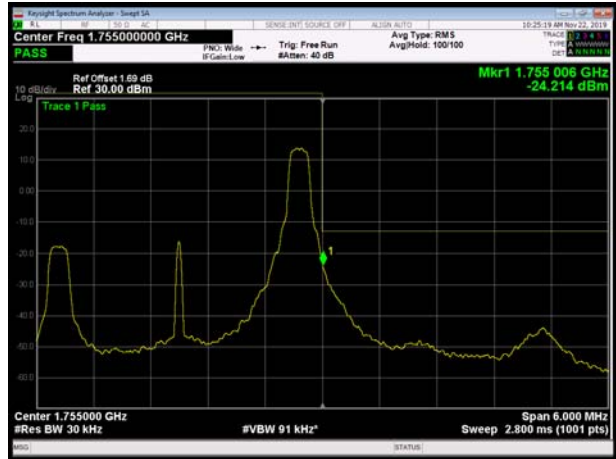



LTE Band 4 16QAM 3MHz CH-Low, 100%RB

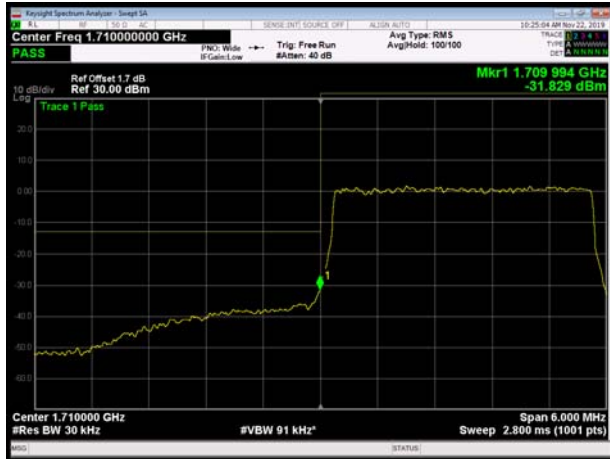

LTE Band 4 16QAM 3MHz CH-High, 100%RB



LTE Band 4 16QAM 5MHz CH-Low, 1 RB

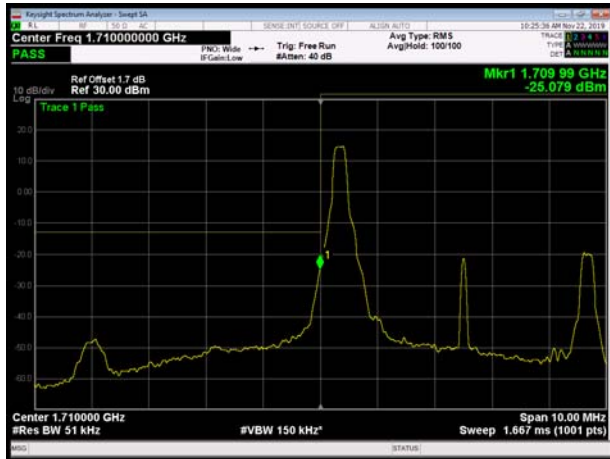

LTE Band 4 16QAM 5MHz CH-High, 1 RB

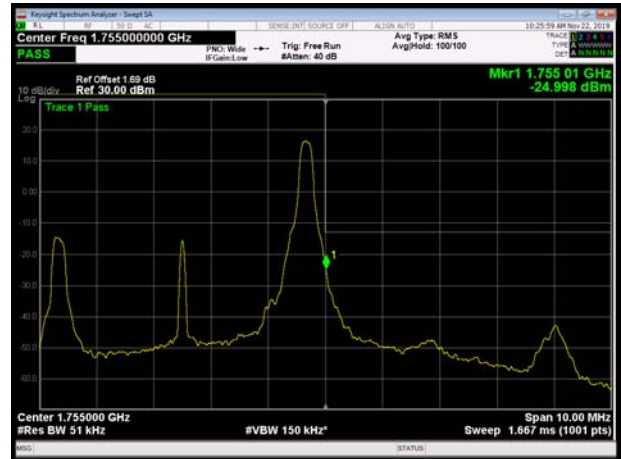

LTE Band 4 16QAM 5MHz CH-Low, 100%RB

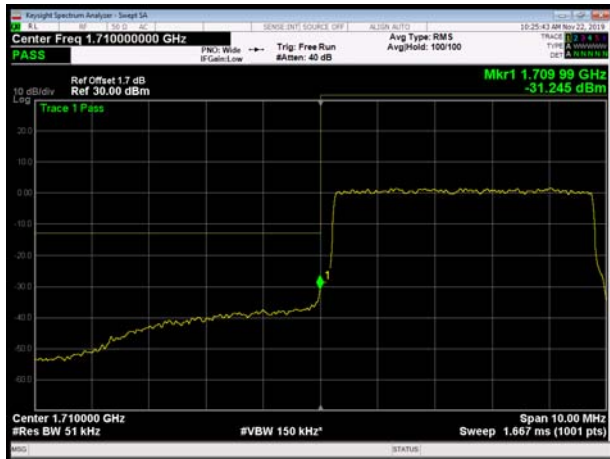

LTE Band 4 16QAM 5MHz CH-High, 100%RB





LTE Band 4 16QAM 10MHz CH-Low, 1 RB

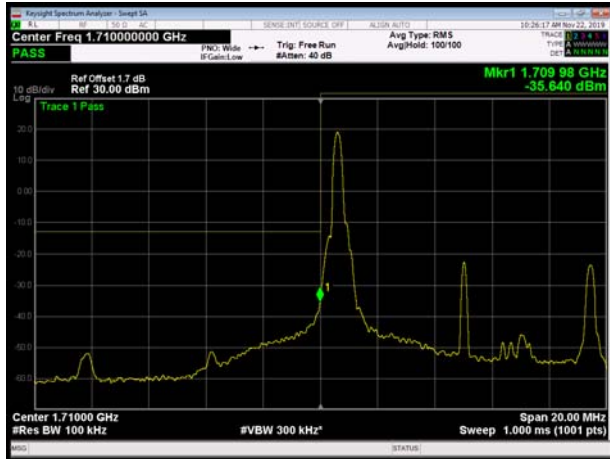

LTE Band 4 16QAM 10MHz CH-High, 1 RB

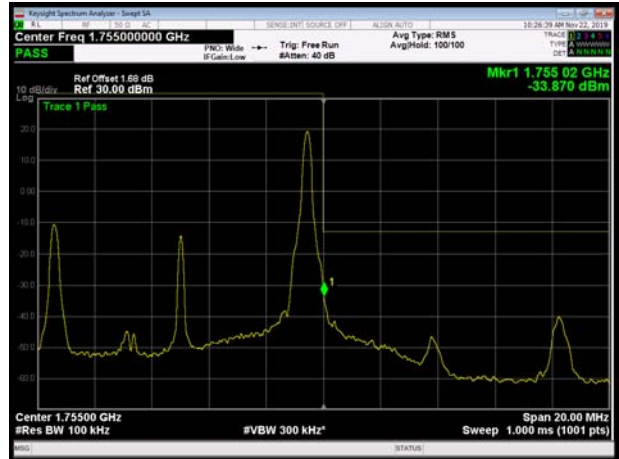

LTE Band 4 16QAM 10MHz CH-Low, 100%RB

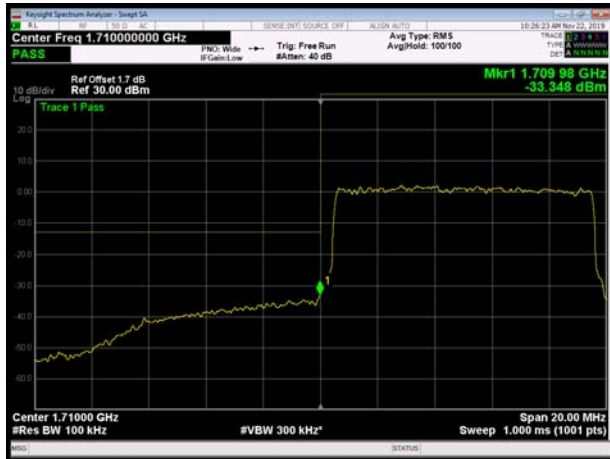

LTE Band 4 16QAM 10MHz CH-High, 100%RB



LTE Band 4 16QAM 15MHz CH-Low, 1 RB

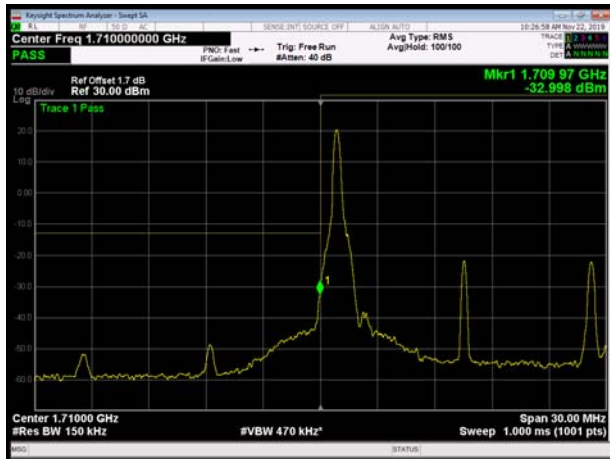

LTE Band 4 16QAM 15MHz CH-High, 1 RB

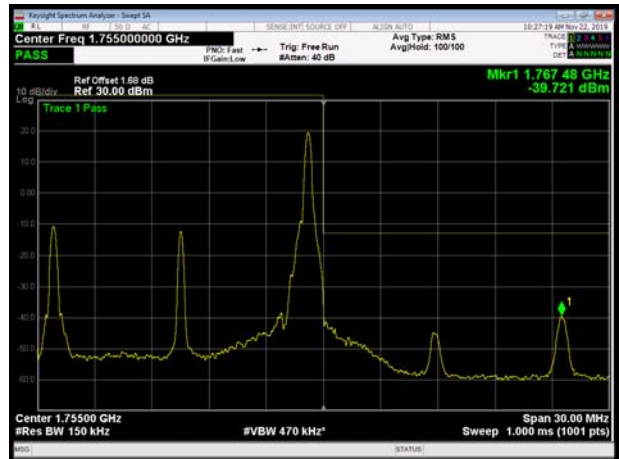



LTE Band 4 16QAM 15MHz CH-Low, 100%RB



LTE Band 4 16QAM 15MHz CH-High, 100%RB



LTE Band 4 16QAM 20MHz CH-Low, 1 RB

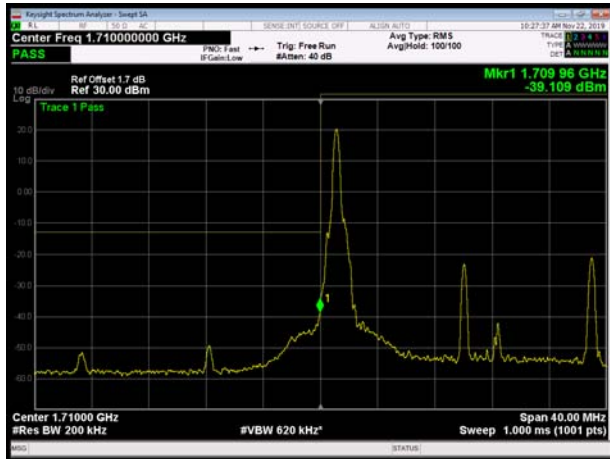

LTE Band 4 16QAM 20MHz CH-High, 1 RB

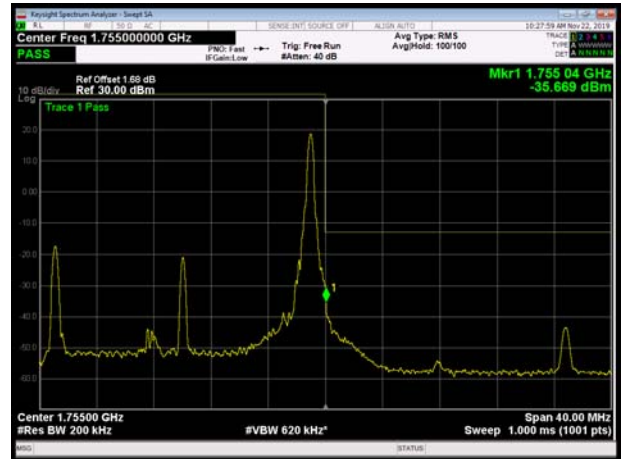

LTE Band 4 16QAM 20MHz CH-Low, 100%RB

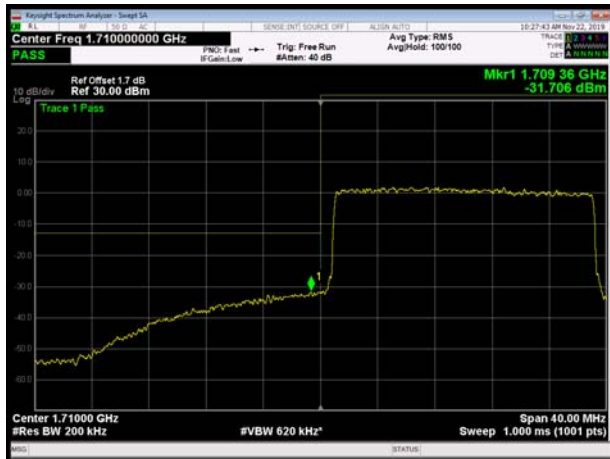

LTE Band 4 16QAM 20MHz CH-High, 100%RB





LTE Band 7 QPSK 5MHz CH-Low, 1 RB

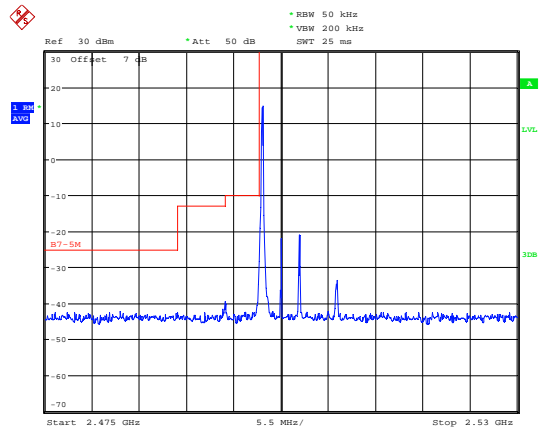

Date: 23.NOV.2019 10:04:50

LTE Band 7 QPSK 5MHz CH-High, 1 RB

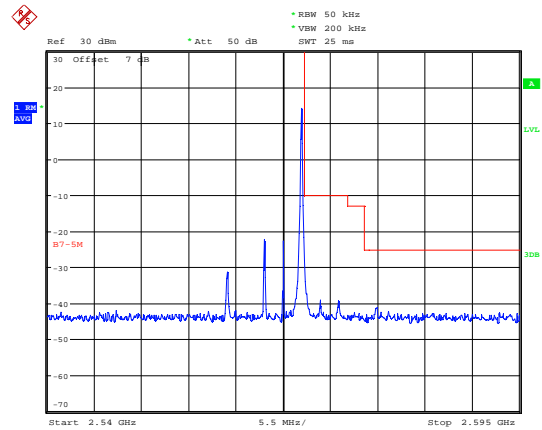

Date: 23.NOV.2019 10:21:40

LTE Band 7 QPSK 5MHz CH-Low, 100%RB

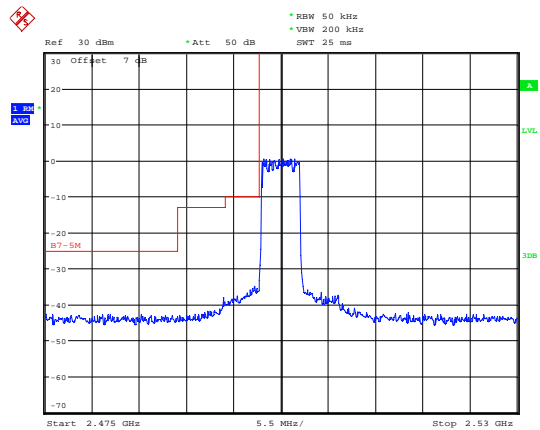

Date: 23.NOV.2019 10:05:05

LTE Band 7 QPSK 5MHz CH-High, 100%RB

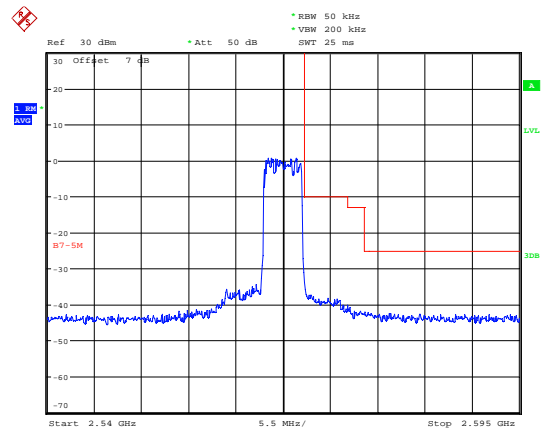

Date: 23.NOV.2019 10:21:54

LTE Band 7 QPSK 10MHz CH-Low, 1 RB

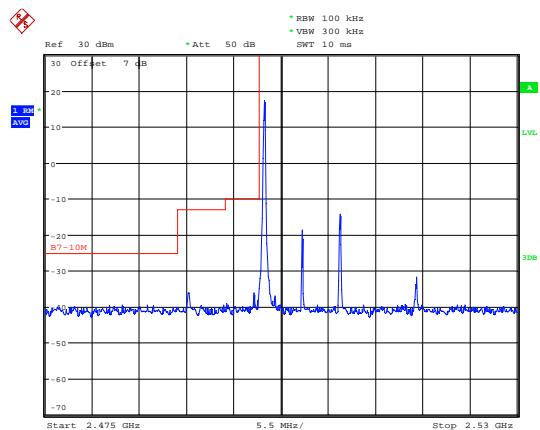

Date: 23.NOV.2019 10:06:42

LTE Band 7 QPSK 10MHz CH-High, 1 RB

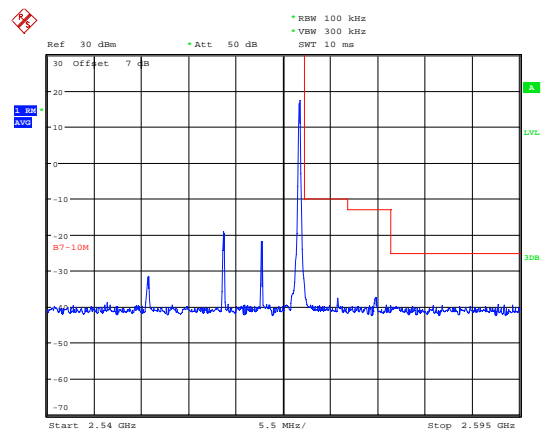

Date: 23.NOV.2019 10:26:59



LTE Band 7 QPSK 10MHz CH-Low, 100%RB

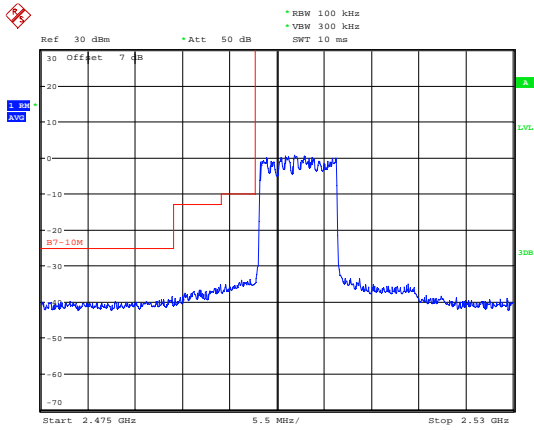

Date: 23.NOV.2019 10:06:54

LTE Band 7 QPSK 10MHz CH-High, 100%RB

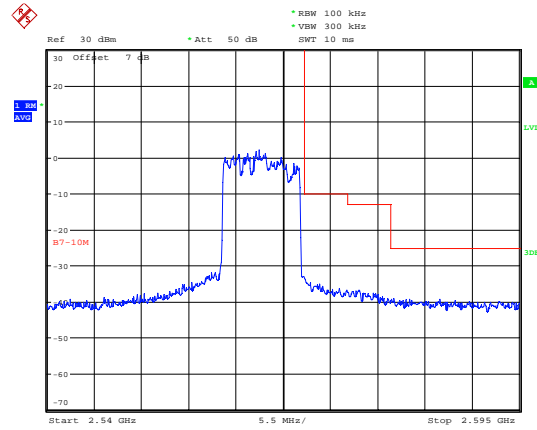

Date: 23.NOV.2019 10:27:11

LTE Band 7 QPSK 15MHz CH-Low, 1 RB

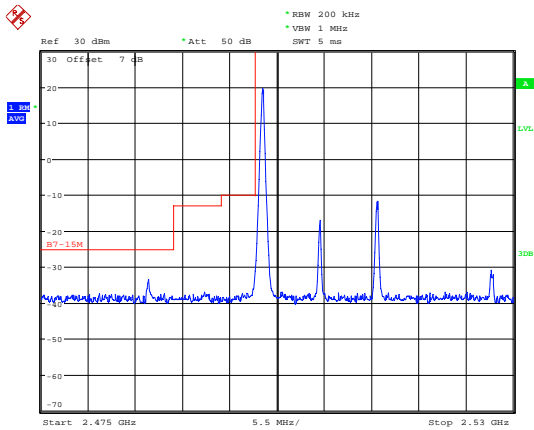

Date: 23.NOV.2019 10:08:17

LTE Band 7 QPSK 15MHz CH-High, 1 RB

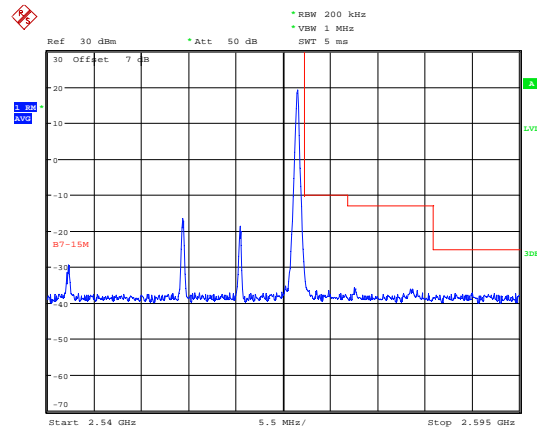

Date: 23.NOV.2019 10:28:29

LTE Band 7 QPSK 15MHz CH-Low, 100%RB

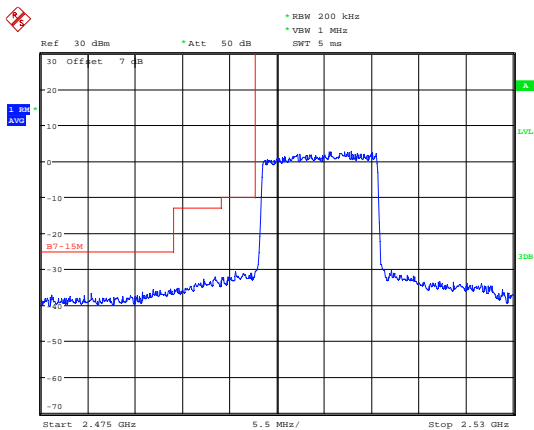

Date: 23.NOV.2019 10:08:29

LTE Band 7 QPSK 15MHz CH-High, 100%RB

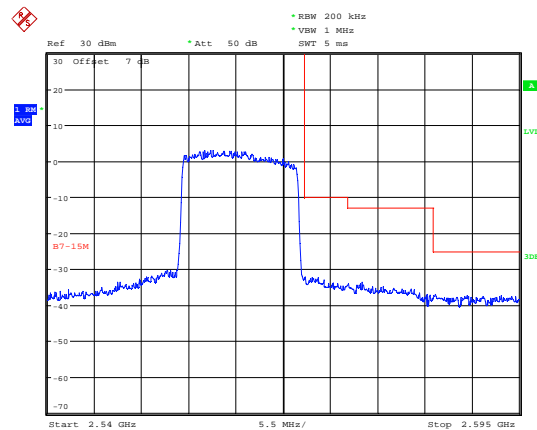

Date: 23.NOV.2019 10:28:43



LTE Band 7 QPSK 20MHz CH-Low, 1 RB

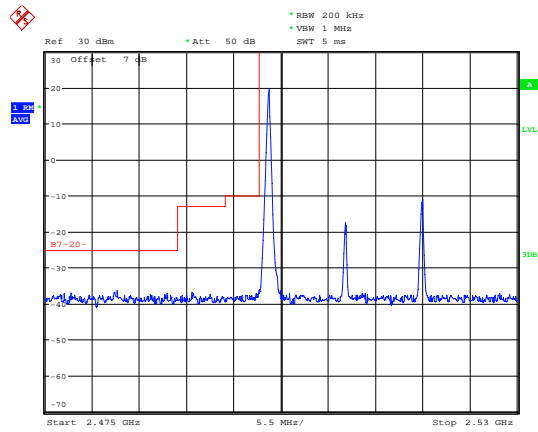

Date: 23.NOV.2019 10:18:03

LTE Band 7 QPSK 20MHz CH-High, 1 RB

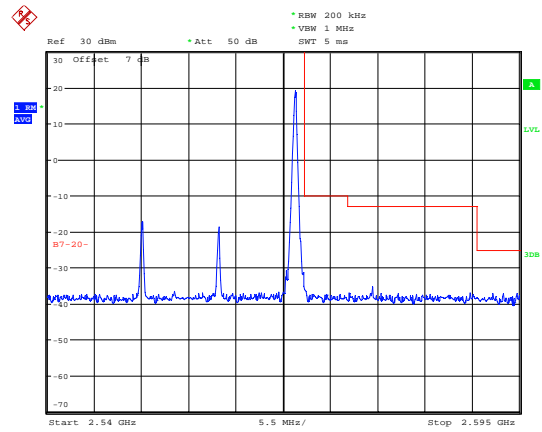

Date: 23.NOV.2019 10:29:53

LTE Band 7 QPSK 20MHz CH-Low, 100%RB

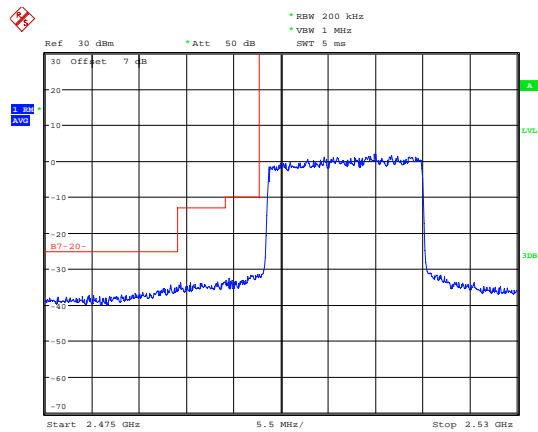

Date: 23.NOV.2019 10:18:15

LTE Band 7 QPSK 20MHz CH-High, 100%RB

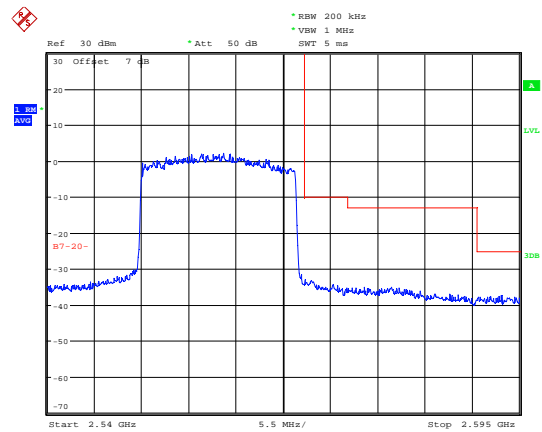

Date: 23.NOV.2019 10:30:08

LTE Band 7 16QAM 5MHz CH-Low, 1 RB

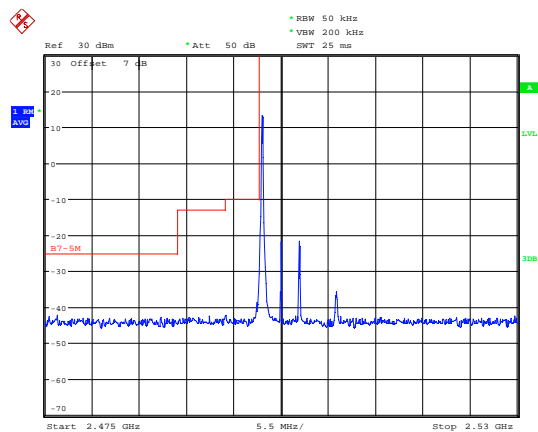

Date: 23.NOV.2019 10:05:25

LTE Band 7 16QAM 5MHz CH-High, 1 RB

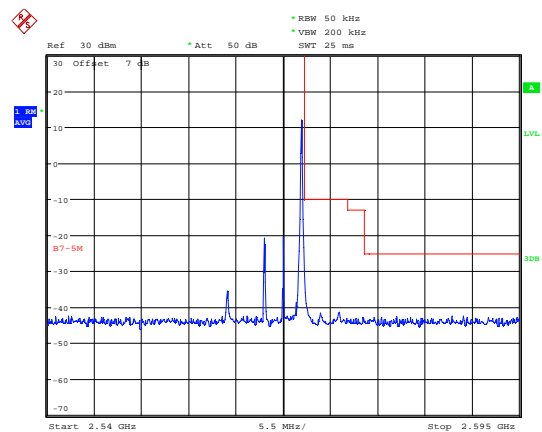

Date: 23.NOV.2019 10:22:07



LTE Band 7 16QAM 5MHz CH-Low, 100%RB

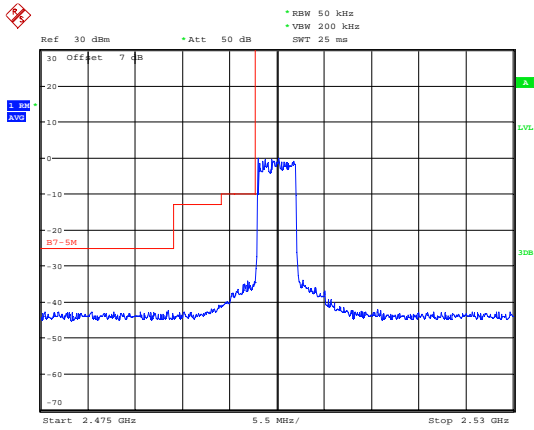

Date: 23.NOV.2019 10:05:37

LTE Band 7 16QAM 5MHz CH-High, 100%RB

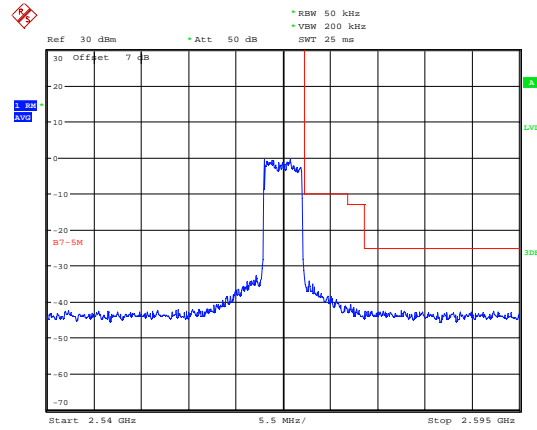

Date: 23.NOV.2019 10:22:18

LTE Band 7 16QAM 10MHz CH-Low, 1 RB

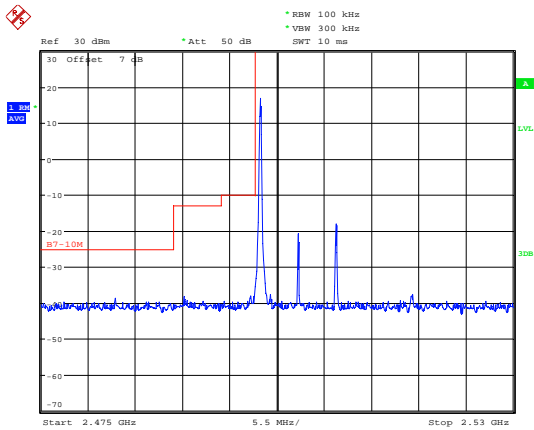

Date: 23.NOV.2019 10:07:07

LTE Band 7 16QAM 10MHz CH-High, 1 RB

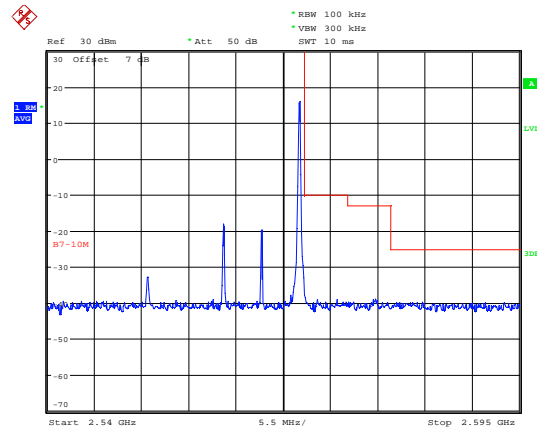

Date: 23.NOV.2019 10:27:24

LTE Band 7 16QAM 10MHz CH-Low, 100%RB

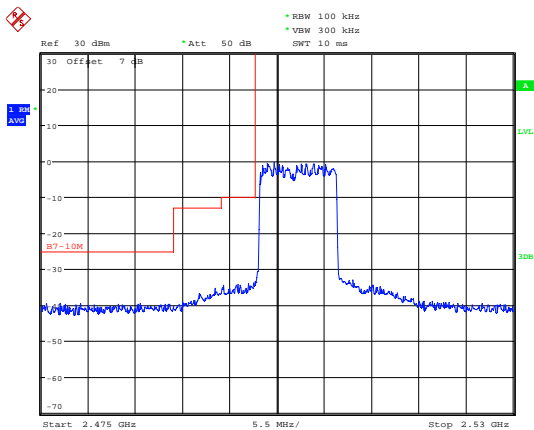

Date: 23.NOV.2019 10:07:20

LTE Band 7 16QAM 10MHz CH-High, 100%RB

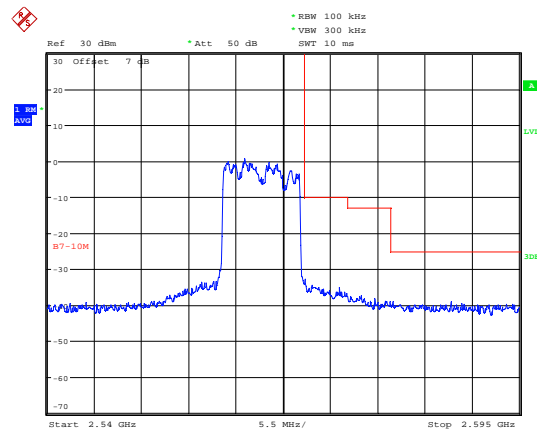

Date: 23.NOV.2019 10:27:37



LTE Band 7 16QAM 15MHz CH-Low, 1 RB

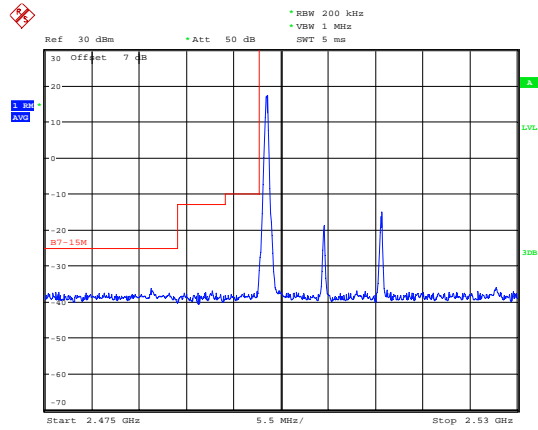

Date: 23.NOV.2019 10:08:42

LTE Band 7 16QAM 15MHz CH-High, 1 RB

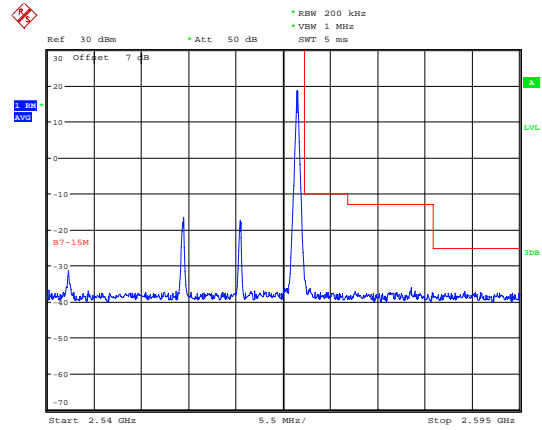

Date: 23.NOV.2019 10:28:57

LTE Band 7 16QAM 15MHz CH-Low, 100%RB

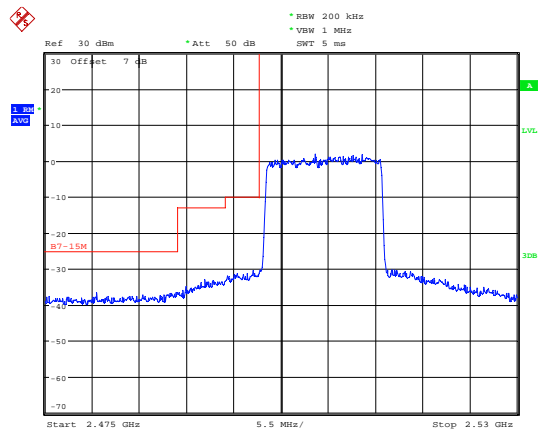

Date: 23.NOV.2019 10:08:54

LTE Band 7 16QAM 15MHz CH-High, 100%RB

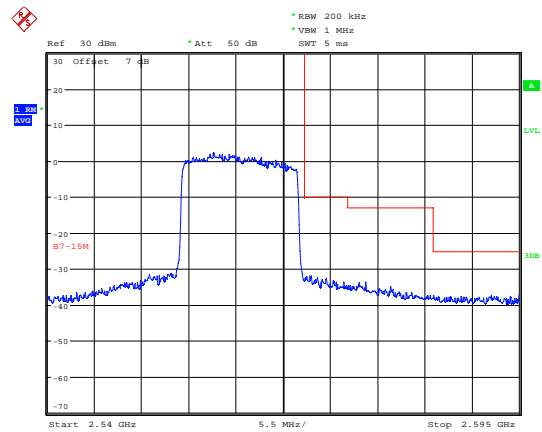

Date: 23.NOV.2019 10:29:09

LTE Band 7 16QAM 20MHz CH-Low, 1 RB

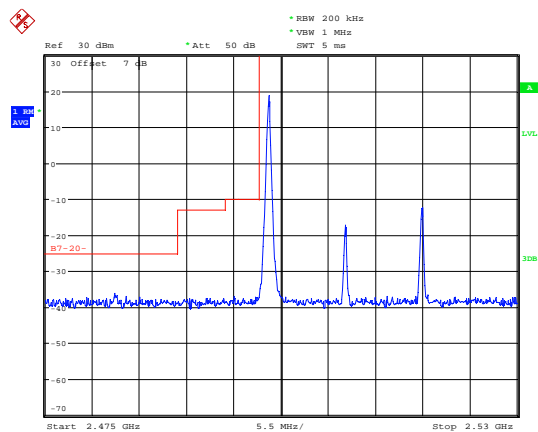

Date: 23.NOV.2019 10:18:28

LTE Band 7 16QAM 20MHz CH-High, 1 RB

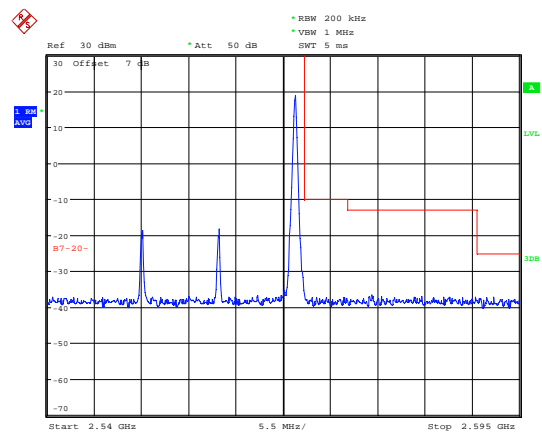

Date: 23.NOV.2019 10:30:21



LTE Band 7 16QAM 20MHz CH-Low, 100%RB

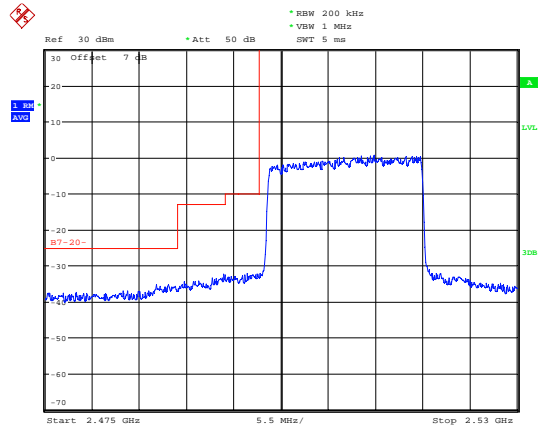

Date: 23.NOV.2019 10:18:40

LTE Band 7 16QAM 20MHz CH-High, 100%RB

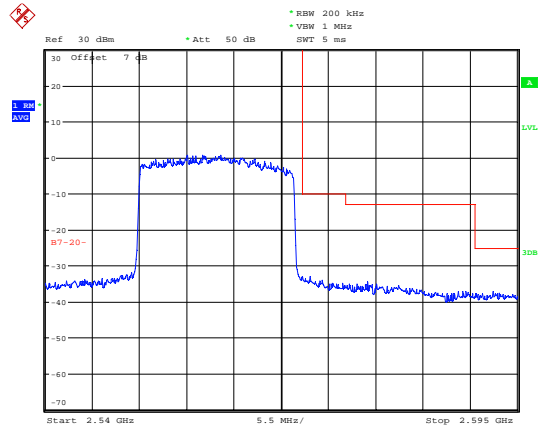

Date: 23.NOV.2019 10:30:34

5.4 Peak-to-Average Power Ratio (PAPR)

Ambient condition

Temperature	Relative humidity	Pressure
23°C ~25°C	45%~50%	101.5kPa

Methods of Measurement

Measure the total peak power and record as Ppk. And measure the total average power and record as PAvg. Both the peak and average power levels must be expressed in the same logarithmic units (e.g., dBm). Determine the PAPR from:

$$PAPR (dB) = Ppk (dBm) - PAvg (dBm).$$

Test Setup

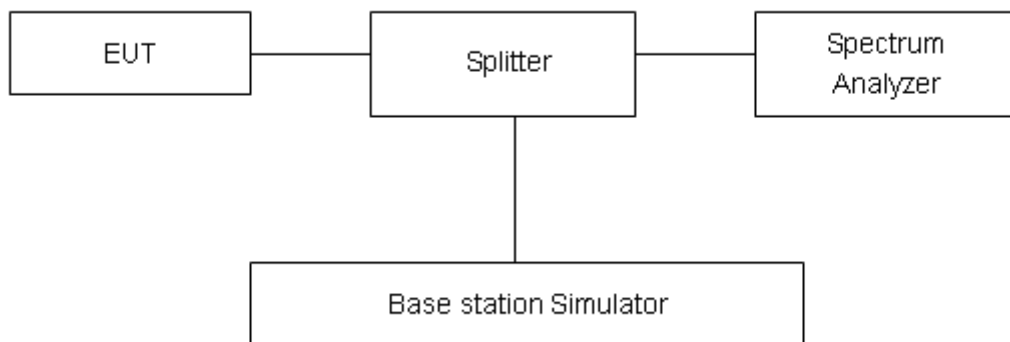

Limits

Rule Part 27.50(d)(5) Equipment employed must be authorized in accordance with the provisions of 24.51. Power measurements for transmissions by stations authorized under this section may be made either in accordance with a Commission-approved average power technique or in compliance with paragraph (d)(6) of this section. In measuring transmissions in this band using an average power technique, the peak-to-average ratio (PAR) of the transmission may not exceed 13 dB.

Measurement Uncertainty

The assessed measurement uncertainty to ensure 95% confidence level for the normal distribution is with the coverage factor k = 2, U= 0.4 dB.



Test Results

LTE Band 4								
Modulation	Bandwidth (MHz)	Channel	Frequency (MHz)	Peak (dBm)	Avg (dBm)	PAPR (dB)	Limit (dB)	Conclusion
QPSK	1.4	19957	1710.7	26.31	20.92	5.39	≤13	PASS
		20175	1732.5	26.54	20.83	5.71	≤13	PASS
		20393	1754.3	26.06	20.88	5.18	≤13	PASS
	3	19965	1711.5	26.50	20.95	5.55	≤13	PASS
		20175	1732.5	26.64	20.89	5.75	≤13	PASS
		20385	1753.5	26.00	20.60	5.40	≤13	PASS
	5	19975	1712.5	26.37	20.88	5.49	≤13	PASS
		20175	1732.5	26.58	20.73	5.85	≤13	PASS
		20375	1752.5	26.07	20.72	5.35	≤13	PASS
	10	20000	1715	26.41	20.91	5.50	≤13	PASS
		20175	1732.5	26.66	20.78	5.88	≤13	PASS
		20350	1750	26.24	20.81	5.43	≤13	PASS
	15	20025	1717.5	26.55	20.87	5.68	≤13	PASS
		20175	1732.5	26.70	20.74	5.96	≤13	PASS
		20325	1747.5	26.52	20.96	5.56	≤13	PASS
20	20050	1720	26.41	20.88	5.53	≤13	PASS	
	20175	1732.5	26.41	20.76	5.65	≤13	PASS	
	20300	1745	26.33	20.95	5.38	≤13	PASS	
16QAM	1.4	19957	1710.7	26.11	19.81	6.30	≤13	PASS
		20175	1732.5	26.52	19.92	6.60	≤13	PASS
		20393	1754.3	25.89	19.73	6.16	≤13	PASS
	3	19965	1711.5	26.17	19.80	6.37	≤13	PASS
		20175	1732.5	26.43	19.75	6.68	≤13	PASS
		20385	1753.5	25.92	19.64	6.28	≤13	PASS
	5	19975	1712.5	26.24	19.93	6.31	≤13	PASS
		20175	1732.5	26.40	19.74	6.66	≤13	PASS
		20375	1752.5	26.01	19.78	6.23	≤13	PASS
	10	20000	1715	26.07	19.74	6.33	≤13	PASS
		20175	1732.5	26.46	19.74	6.72	≤13	PASS
		20350	1750	26.03	19.71	6.32	≤13	PASS
	15	20025	1717.5	26.25	19.81	6.44	≤13	PASS
		20175	1732.5	26.52	19.81	6.71	≤13	PASS
		20325	1747.5	26.40	20.05	6.35	≤13	PASS
20	20050	1720	26.22	19.85	6.37	≤13	PASS	
	20175	1732.5	26.31	19.78	6.53	≤13	PASS	
	20300	1745	26.18	19.86	6.32	≤13	PASS	



LTE Band 7								
Modulation	Bandwidth (MHz)	Channel	Frequency (MHz)	Peak (dBm)	Avg (dBm)	PAPR (dB)	Limit (dB)	Conclusion
QPSK	5	20775	2502.5	26.40	21.41	4.99	≤13	PASS
		21100	2535	26.23	21.17	5.06	≤13	PASS
		21425	2567.5	26.54	21.50	5.04	≤13	PASS
	10	20800	2505	26.58	21.45	5.13	≤13	PASS
		21100	2535	26.27	21.12	5.15	≤13	PASS
		21400	2565	26.73	21.57	5.16	≤13	PASS
	15	20825	2507.5	26.87	21.41	5.46	≤13	PASS
		21100	2535	26.51	21.14	5.37	≤13	PASS
		21375	2562.5	26.89	21.55	5.34	≤13	PASS
	20	20850	2510	26.70	21.40	5.30	≤13	PASS
		21100	2535	26.40	21.17	5.23	≤13	PASS
		21350	2560	26.55	21.44	5.11	≤13	PASS
16QAM	5	20775	2502.5	26.29	20.40	5.89	≤13	PASS
		21100	2535	26.19	20.26	5.93	≤13	PASS
		21425	2567.5	26.53	20.59	5.94	≤13	PASS
	10	20800	2505	26.49	20.48	6.01	≤13	PASS
		21100	2535	26.21	20.20	6.01	≤13	PASS
		21400	2565	26.63	20.52	6.11	≤13	PASS
	15	20825	2507.5	26.66	20.44	6.22	≤13	PASS
		21100	2535	26.35	20.21	6.14	≤13	PASS
		21375	2562.5	26.75	20.54	6.21	≤13	PASS
	20	20850	2510	26.60	20.41	6.19	≤13	PASS
		21100	2535	26.30	20.24	6.06	≤13	PASS
		21350	2560	26.59	20.44	6.15	≤13	PASS

5.5 Frequency Stability

Ambient condition

Temperature	Relative humidity	Pressure
23°C ~25°C	45%~50%	101.5kPa

Method of Measurement

Frequency Stability (Temperature Variation)

The temperature inside the climate chamber is varied from -30°C to +60°C in 10°C step size.

(1) With all power removed, the temperature was decreased to -10°C and permitted to stabilize for three hours.

(2) Measure the carrier frequency with the test equipment in a “call mode”. These measurements should be made within 1 minute of powering up the mobile station, to prevent significant self warming.

(3) Repeat the above measurements at 10°C increments from -30°C to +60°C. Allow at least 1.5 hours at each temperature, un-powered, before making measurements.

Frequency Stability (Voltage Variation)

The frequency stability shall be measured with variation of primary supply voltage as follows:

(1) Vary primary supply voltage from 85 to 115 percent of the nominal value for other than hand carried battery equipment.

(2) For hand carried, battery powered equipment, reduce primary supply voltage to the battery-operating end point which shall be specified by the manufacturer.

This transceiver is specified to operate with an input voltage of between 22.8 V and 25.2 V, with a nominal voltage of 24V.

Test setup

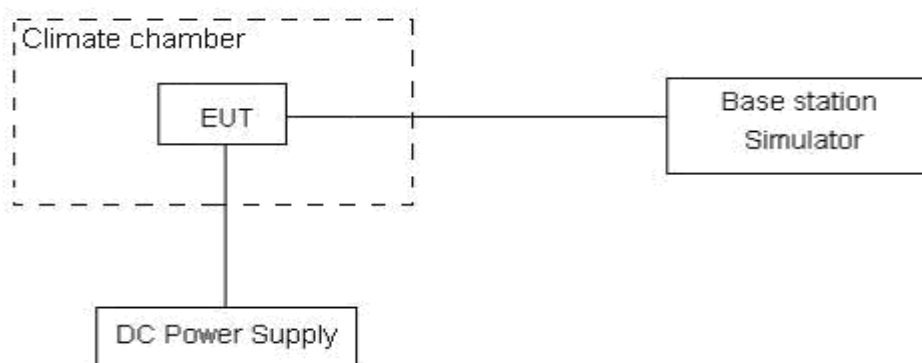

Limits

The frequency stability shall be sufficient to ensure that the fundamental emissions stay within the authorized bands of operation.

Measurement Uncertainty

The assessed measurement uncertainty to ensure 99.75% confidence level for the normal distribution is with the coverage factor $k = 3, U = 0.01\text{ppm}$.



Test Result

LTE Band 4						
Condition		Freq.Error (Hz)	Freq.Error (Hz)	Frequency Stability (ppm)	Frequency Stability (ppm)	Verdict
BANDWIDTH	1.4MHz					
Temperature	Voltage	16QAM	QPSK	16QAM	QPSK	
Normal (25°C)	Normal	9.77	8.78	0.00520	0.00467	PASS
Extreme (60°C)		7.90	15.41	0.00420	0.00819	PASS
Extreme (50°C)		17.90	15.39	0.00952	0.00819	PASS
Extreme (40°C)		11.98	17.12	0.00637	0.00911	PASS
Extreme (30°C)		12.96	8.72	0.00689	0.00464	PASS
Extreme (20°C)		1.83	8.87	0.00097	0.00472	PASS
Extreme (10°C)		16.54	10.02	0.00880	0.00533	PASS
Extreme (0°C)		8.71	9.15	0.00464	0.00487	PASS
Extreme (-10°C)		2.52	4.25	0.00134	0.00226	PASS
Extreme (-20°C)		8.36	10.07	0.00445	0.00536	PASS
Extreme (-30°C)		4.19	1.46	0.00223	0.00078	PASS
25°C	LV	11.13	12.77	0.00592	0.00679	PASS
	HV	1.08	3.28	0.00057	0.00175	PASS
Condition		Freq.Error (Hz)	Freq.Error (Hz)	Frequency Stability (ppm)	Frequency Stability (ppm)	Verdict
BANDWIDTH	3MHz					
Temperature	Voltage	16QAM	QPSK	16QAM	QPSK	
Normal (25°C)	Normal	8.78	15.33	0.00467	0.00816	PASS
Extreme (60°C)		10.21	15.96	0.00543	0.00849	PASS
Extreme (50°C)		1.13	10.89	0.00060	0.00579	PASS
Extreme (40°C)		13.40	4.87	0.00713	0.00259	PASS
Extreme (30°C)		3.76	17.86	0.00200	0.00950	PASS
Extreme (20°C)		2.75	12.13	0.00146	0.00645	PASS
Extreme (10°C)		14.58	1.36	0.00776	0.00072	PASS
Extreme (0°C)		16.53	5.66	0.00879	0.00301	PASS
Extreme (-10°C)		17.78	11.56	0.00946	0.00615	PASS
Extreme (-20°C)		17.59	5.34	0.00935	0.00284	PASS
Extreme (-30°C)		16.25	15.74	0.00864	0.00837	PASS
25°C	LV	14.05	15.45	0.00748	0.00822	PASS
	HV	16.36	14.65	0.00870	0.00779	PASS
Condition		Freq.Error (Hz)	Freq.Error (Hz)	Frequency Stability (ppm)	Frequency Stability (ppm)	Verdict
BANDWIDTH	5MHz					
Temperature	Voltage	16QAM	QPSK	16QAM	QPSK	
Normal (25°C)	Normal	9.89	8.96	0.00526	0.00476	PASS
Extreme (60°C)		12.95	9.84	0.00689	0.00524	PASS



Extreme (50°C)		2.29	5.18	0.00122	0.00275	PASS
Extreme (40°C)		16.84	14.74	0.00896	0.00784	PASS
Extreme (30°C)		4.17	2.95	0.00222	0.00157	PASS
Extreme (20°C)		11.04	13.72	0.00587	0.00730	PASS
Extreme (10°C)		4.25	3.53	0.00226	0.00188	PASS
Extreme (0°C)		6.45	13.05	0.00343	0.00694	PASS
Extreme (-10°C)		15.83	4.21	0.00842	0.00224	PASS
Extreme (-20°C)		5.69	16.63	0.00303	0.00885	PASS
Extreme (-30°C)		3.50	9.31	0.00186	0.00495	PASS
25°C	LV	1.08	6.57	0.00058	0.00349	PASS
	HV	14.49	2.71	0.00771	0.00144	PASS
Condition		Freq.Error (Hz)	Freq.Error (Hz)	Frequency Stability (ppm)	Frequency Stability (ppm)	Verdict
BANDWIDTH	10MHz					
Temperature	Voltage	16QAM	QPSK	16QAM	QPSK	
Normal (25°C)	Normal	15.17	12.04	0.00807	0.00641	PASS
Extreme (60°C)		1.54	6.71	0.00082	0.00357	PASS
Extreme (50°C)		4.35	9.88	0.00232	0.00525	PASS
Extreme (40°C)		17.88	15.37	0.00951	0.00818	PASS
Extreme (30°C)		10.90	5.19	0.00580	0.00276	PASS
Extreme (20°C)		7.29	11.93	0.00388	0.00635	PASS
Extreme (10°C)		3.76	12.99	0.00200	0.00691	PASS
Extreme (0°C)		11.58	15.75	0.00616	0.00838	PASS
Extreme (-10°C)		5.16	5.95	0.00274	0.00317	PASS
Extreme (-20°C)		5.93	5.92	0.00315	0.00315	PASS
Extreme (-30°C)		8.89	5.95	0.00473	0.00316	PASS
25°C		LV	6.96	13.08	0.00370	0.00696
	HV	11.26	8.99	0.00599	0.00478	PASS
Condition		Freq.Error (Hz)	Freq.Error (Hz)	Frequency Stability (ppm)	Frequency Stability (ppm)	Verdict
BANDWIDTH	15MHz					
Temperature	Voltage	16QAM	QPSK	16QAM	QPSK	
Normal (25°C)	Normal	5.59	4.94	0.00297	0.00263	PASS
Extreme (60°C)		4.20	8.03	0.00224	0.00427	PASS
Extreme (50°C)		9.31	5.96	0.00495	0.00317	PASS
Extreme (40°C)		3.02	15.33	0.00161	0.00815	PASS
Extreme (30°C)		10.97	6.56	0.00583	0.00349	PASS
Extreme (20°C)		6.59	11.75	0.00350	0.00625	PASS
Extreme (10°C)		2.93	14.63	0.00156	0.00778	PASS
Extreme (0°C)		2.49	6.71	0.00132	0.00357	PASS
Extreme (-10°C)		8.24	5.37	0.00438	0.00286	PASS
Extreme (-20°C)		11.70	13.00	0.00622	0.00691	PASS



Condition		Freq.Error (Hz)	Freq.Error (Hz)	Frequency Stability (ppm)	Frequency Stability (ppm)	Verdict
BANDWIDTH	20MHz	16QAM	QPSK	16QAM	QPSK	
Temperature	Voltage					
Extreme (-30°C)						
25°C	LV	8.41	1.32	0.00448	0.00070	PASS
	HV	14.13	5.11	0.00752	0.00272	PASS
Normal (25°C)	Normal	14.43	1.71	0.00767	0.00091	PASS
Extreme (60°C)		6.35	17.99	0.00338	0.00957	PASS
Extreme (50°C)		11.69	7.46	0.00622	0.00397	PASS
Extreme (40°C)		16.30	17.25	0.00867	0.00918	PASS
Extreme (30°C)		14.04	6.78	0.00747	0.00360	PASS
Extreme (20°C)		10.63	6.61	0.00566	0.00351	PASS
Extreme (10°C)		3.72	3.36	0.00198	0.00179	PASS
Extreme (0°C)		10.32	6.54	0.00549	0.00348	PASS
Extreme (-10°C)		7.07	13.52	0.00376	0.00719	PASS
Extreme (-20°C)		12.55	3.51	0.00668	0.00187	PASS
Extreme (-30°C)		11.94	5.65	0.00635	0.00301	PASS
25°C		LV	7.29	15.33	0.00388	0.00816
	HV	6.69	15.65	0.00356	0.00832	PASS

LTE Band 7						
Condition		Freq.Error (Hz)	Freq.Error (Hz)	Frequency Stability (ppm)	Frequency Stability (ppm)	Verdict
BANDWIDTH	5MHz	16QAM	QPSK	16QAM	QPSK	
Temperature	Voltage					
Normal (25°C)	Normal					
Extreme (60°C)		8.03	13.53	0.00427	0.00720	PASS
Extreme (50°C)		3.70	11.21	0.00197	0.00596	PASS
Extreme (40°C)		9.48	7.58	0.00504	0.00403	PASS
Extreme (30°C)		4.19	7.36	0.00223	0.00391	PASS
Extreme (20°C)		12.26	5.07	0.00652	0.00270	PASS
Extreme (10°C)		8.85	13.89	0.00471	0.00739	PASS
Extreme (0°C)		3.10	7.80	0.00165	0.00415	PASS
Extreme (-10°C)		8.51	7.59	0.00453	0.00404	PASS
Extreme (-20°C)		8.50	14.70	0.00452	0.00782	PASS
Extreme (-30°C)		15.80	8.63	0.00841	0.00459	PASS
25°C		LV	14.25	4.13	0.00758	0.00220
	HV	5.44	3.24	0.00290	0.00172	PASS
Condition		Freq.Error (Hz)	Freq.Error (Hz)	Frequency Stability (ppm)	Frequency Stability (ppm)	Verdict
BANDWIDTH	10MHz					



Temperature	Voltage	16QAM	QPSK	16QAM	QPSK	
Normal (25°C)	Normal	3.47	14.99	0.00184	0.00798	PASS
Extreme (60°C)		13.12	8.41	0.00698	0.00447	PASS
Extreme (50°C)		10.21	7.19	0.00543	0.00382	PASS
Extreme (40°C)		10.18	4.90	0.00542	0.00261	PASS
Extreme (30°C)		16.32	8.36	0.00868	0.00444	PASS
Extreme (20°C)		10.51	14.77	0.00559	0.00786	PASS
Extreme (10°C)		6.37	15.54	0.00339	0.00827	PASS
Extreme (0°C)		12.41	4.50	0.00660	0.00239	PASS
Extreme (-10°C)		14.31	4.81	0.00761	0.00256	PASS
Extreme (-20°C)		13.07	14.26	0.00695	0.00759	PASS
Extreme (-30°C)		9.96	14.65	0.00530	0.00779	PASS
25°C		LV	17.39	9.73	0.00925	0.00518
	HV	14.65	12.49	0.00779	0.00664	PASS
Condition		Freq.Error (Hz)	Freq.Error (Hz)	Frequency Stability (ppm)	Frequency Stability (ppm)	Verdict
BANDWIDTH	15MHz					
Temperature	Voltage	16QAM	QPSK	16QAM	QPSK	
Normal (25°C)	Normal	9.50	11.85	0.00505	0.00630	PASS
Extreme (60°C)		12.04	17.17	0.00640	0.00913	PASS
Extreme (50°C)		11.40	15.76	0.00607	0.00838	PASS
Extreme (40°C)		5.38	4.44	0.00286	0.00236	PASS
Extreme (30°C)		3.41	3.62	0.00182	0.00193	PASS
Extreme (20°C)		2.88	12.68	0.00153	0.00674	PASS
Extreme (10°C)		4.28	16.25	0.00228	0.00864	PASS
Extreme (0°C)		11.86	13.60	0.00631	0.00723	PASS
Extreme (-10°C)		8.08	15.33	0.00430	0.00815	PASS
Extreme (-20°C)		4.89	1.91	0.00260	0.00101	PASS
Extreme (-30°C)		10.59	17.35	0.00563	0.00923	PASS
25°C		LV	10.95	16.44	0.00582	0.00874
	HV	9.61	9.09	0.00511	0.00484	PASS
Condition		Freq.Error (Hz)	Freq.Error (Hz)	Frequency Stability (ppm)	Frequency Stability (ppm)	Verdict
BANDWIDTH	20MHz					
Temperature	Voltage	16QAM	QPSK	16QAM	QPSK	
Normal (25°C)	Normal	3.68	2.11	0.00196	0.00112	PASS
Extreme (60°C)		11.96	8.22	0.00636	0.00437	PASS
Extreme (50°C)		4.94	16.57	0.00263	0.00881	PASS
Extreme (40°C)		8.04	3.33	0.00428	0.00177	PASS
Extreme (30°C)		2.19	5.50	0.00116	0.00293	PASS
Extreme (20°C)		7.21	9.12	0.00384	0.00485	PASS
Extreme (10°C)		1.87	1.32	0.00099	0.00070	PASS



Extreme (0°C)		4.37	10.67	0.00233	0.00568	PASS
Extreme (-10°C)		14.88	7.88	0.00792	0.00419	PASS
Extreme (-20°C)		2.42	14.91	0.00129	0.00793	PASS
Extreme (-30°C)		8.65	13.12	0.00460	0.00698	PASS
25°C	LV	17.78	5.60	0.00946	0.00298	PASS
	HV	1.35	11.07	0.00072	0.00589	PASS

5.6 Spurious Emissions at Antenna Terminals

Ambient condition

Temperature	Relative humidity	Pressure
23°C ~25°C	45%~50%	101.5kPa

Method of Measurement

The EUT was connected to Spectrum Analyzer and Base Station Simulator via power Splitter. The measurement is carried out using a spectrum analyzer. The spectrum analyzer scans from 9kHz to the 10th harmonic of the carrier. The peak detector is used.

RBW is set to 100kHz, VBW is set to 300kHz for 30MHz~1GHz

RBW is set to 1MHz, VBW is set to 3MHz for above 1GHz, Sweep is set to ATUO.

Of those disturbances below (limit – 20 dB), the mark is not required for the EUT.

The modulation mode and RB allocation refer to section 5.1, using the maximum output power configuration.

Test setup

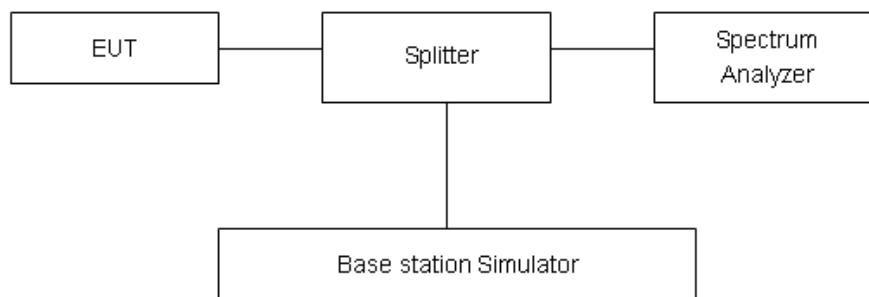

Limits

Rule Part 27.53(h) specifies that “for operations in the 1695-1710 MHz, 1710-1755 MHz, 1755-1780 MHz, 1915-1920 MHz, 1995-2000 MHz, 2000-2020 MHz, 2110-2155 MHz, 2155-2180 MHz, and 2180-2200 bands, the power of any emission outside a licensee's frequency block shall be attenuated below the transmitter power (P) in watts by at least 43 + 10 log₁₀ (P) dB..”

Rule Part 27.53(m) 55 + 10 log (P) dB on all frequencies more than X megahertz from the channel edge, where X is the greater of 6 megahertz or the actual emission bandwidth as defined in paragraph (m)(4) of this section.

Part 27.53 (h) Limit	-13 dBm
Part 27.53(m) Limit	-25 dBm

Measurement Uncertainty

The assessed measurement uncertainty to ensure 99.75% confidence level for the normal distribution is with the coverage factor $k = 1.96$.

Frequency	Uncertainty
9kHz-1GHz	0.684 dB
1GHz-27GHz	1.407 dB



Test Result

Sweep the whole frequency band through the range from 9kHz to the 10th harmonic of the carrier, the emissions more than 20 dB below the limit are not reported.

The signal beyond the limit is carrier.

LTE Band 4 1.4MHz CH-Low 9kHz~20GHz

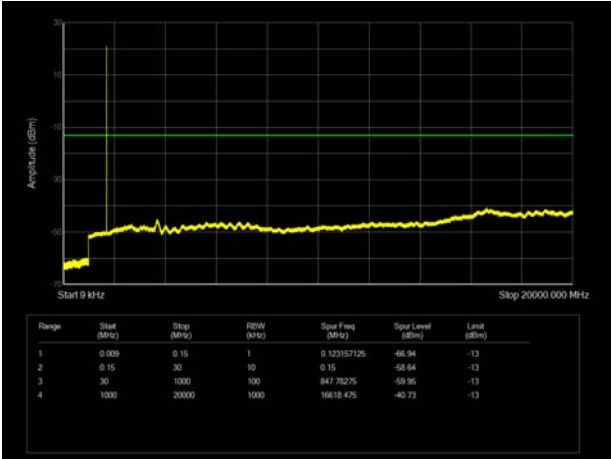

LTE Band 4 3MHz CH-Low 9kHz~20GHz

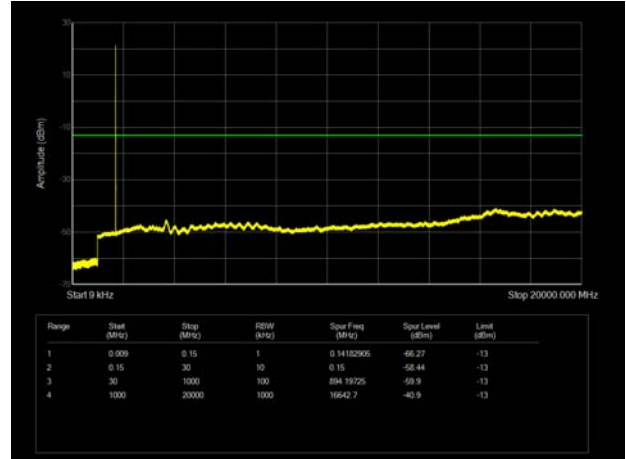

LTE Band 4 1.4MHz CH-Middle 9kHz~20GHz

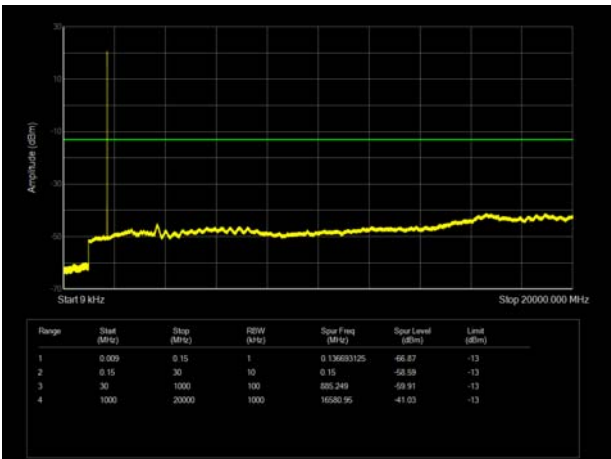

LTE Band 4 3MHz CH-Middle 9kHz~20GHz

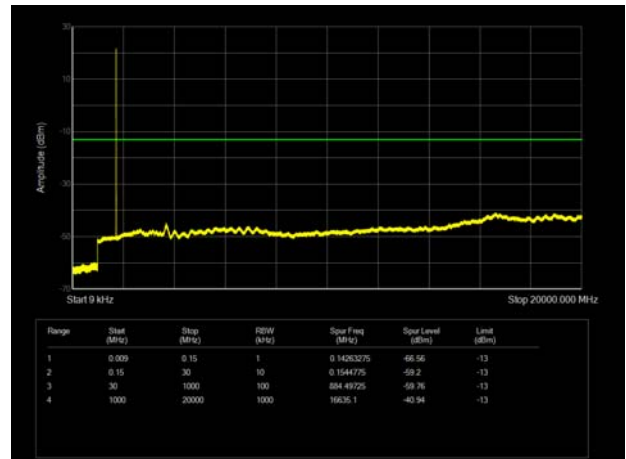

LTE Band 4 1.4MHz CH-High 9kHz~20GHz

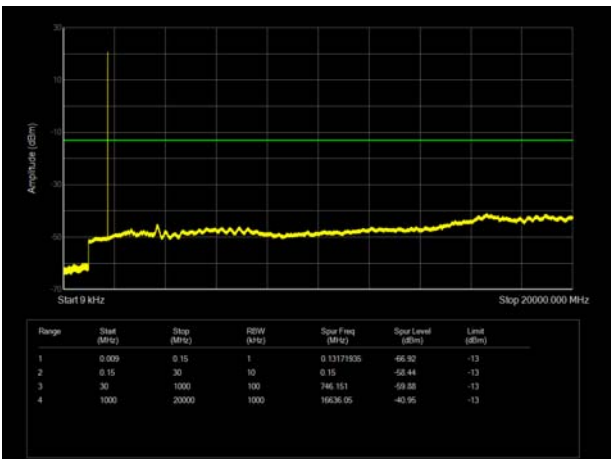

LTE Band 4 3MHz CH-High 9kHz~20GHz

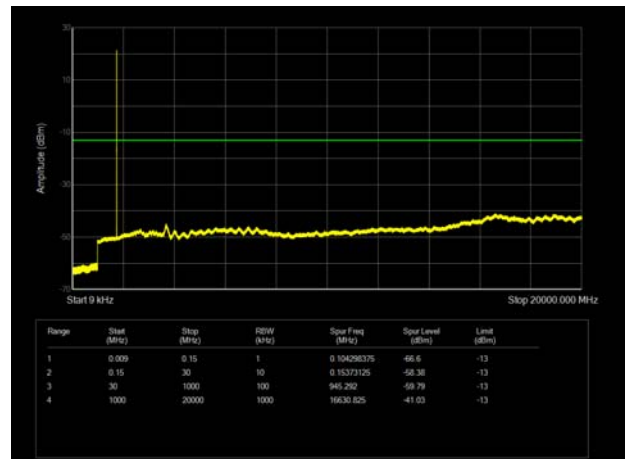



LTE Band 4 5MHz CH-Low 9kHz~20GHz

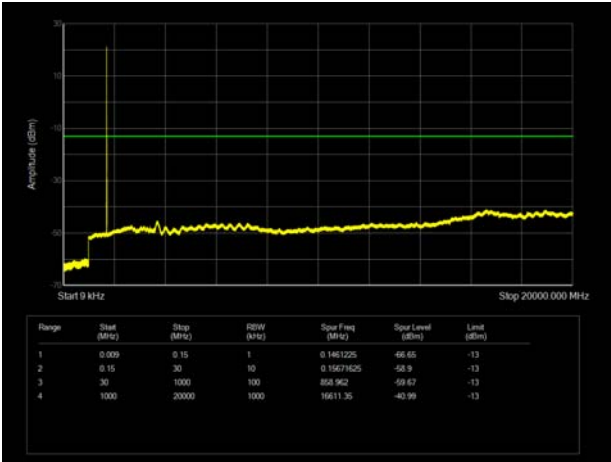

LTE Band 4 10MHz CH-Low 9kHz~20GHz

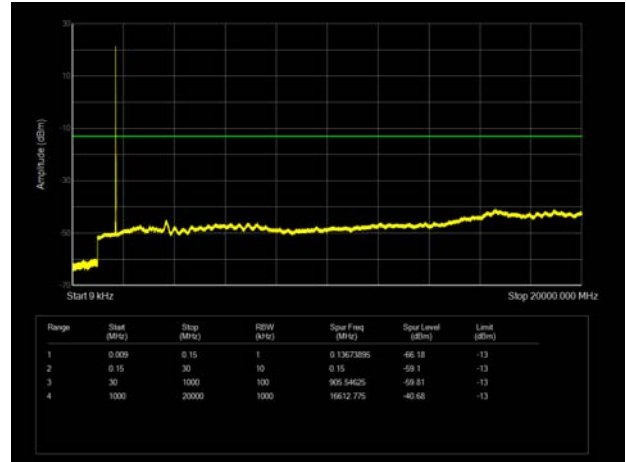

LTE Band 4 5MHz CH-Middle 9kHz~20GHz

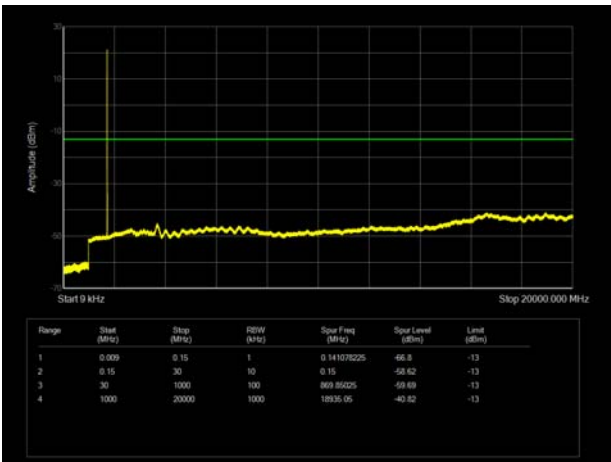

LTE Band 4 10MHz CH-Middle 9kHz~20GHz

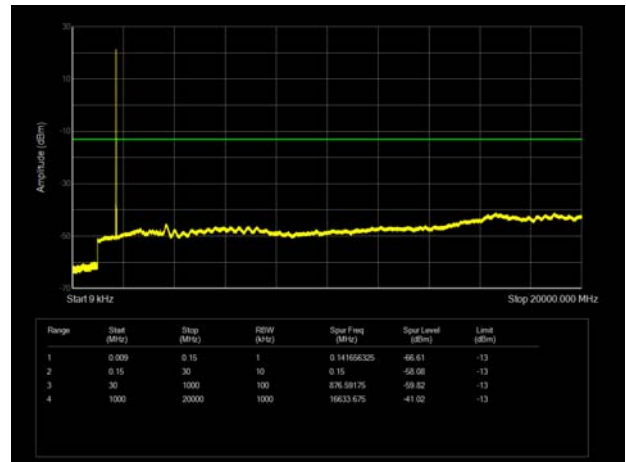

LTE Band 4 5MHz CH-High 9kHz~20GHz

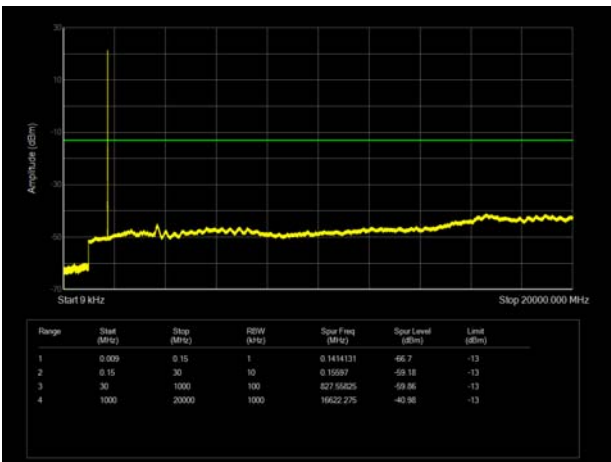

LTE Band 4 10MHz CH-High 9kHz~20GHz

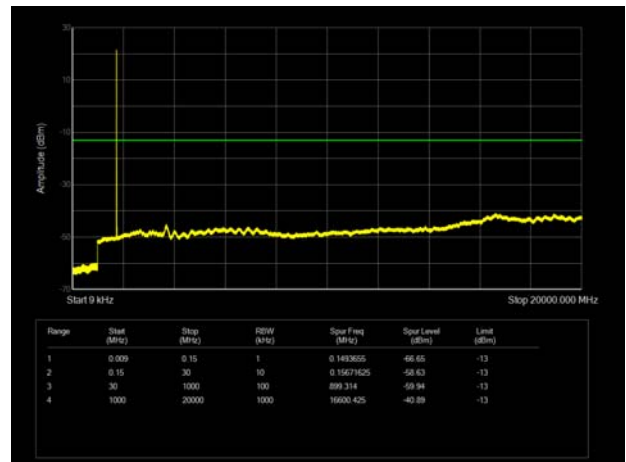



LTE Band 4 15MHz CH-Low 9kHz~20GHz

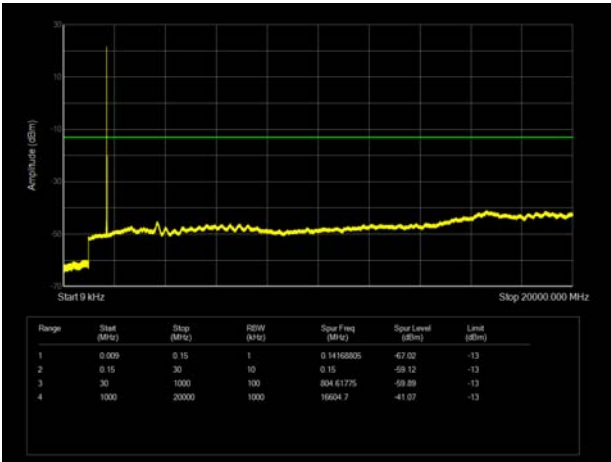

LTE Band 4 20MHz CH-Low 9kHz~20GHz

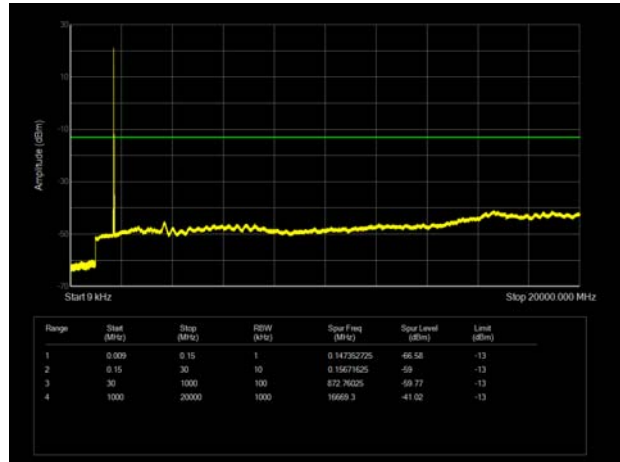

LTE Band 4 15MHz CH-Middle 9kHz~20GHz

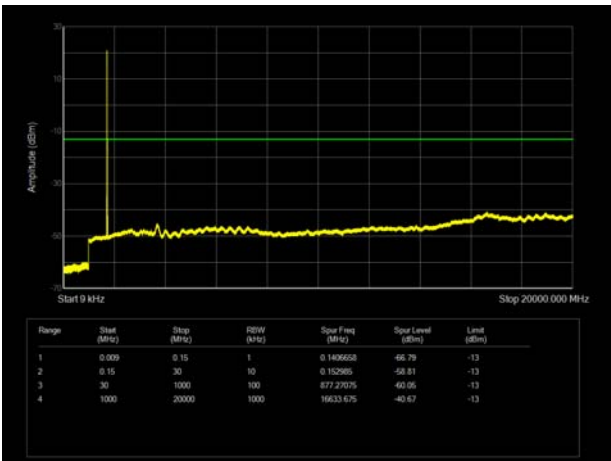

LTE Band 4 20MHz CH-Middle 9kHz~20GHz

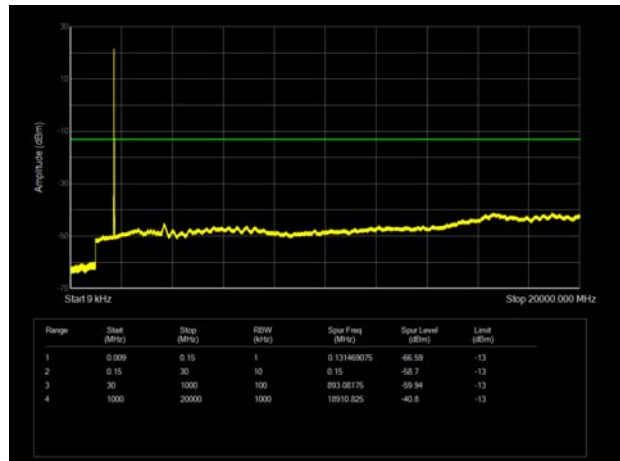

LTE Band 4 15MHz CH-High 9kHz~20GHz

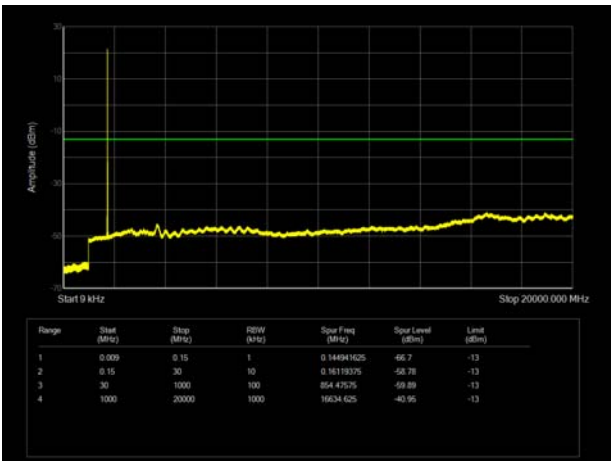

LTE Band 4 20MHz CH-High 9kHz~20GHz

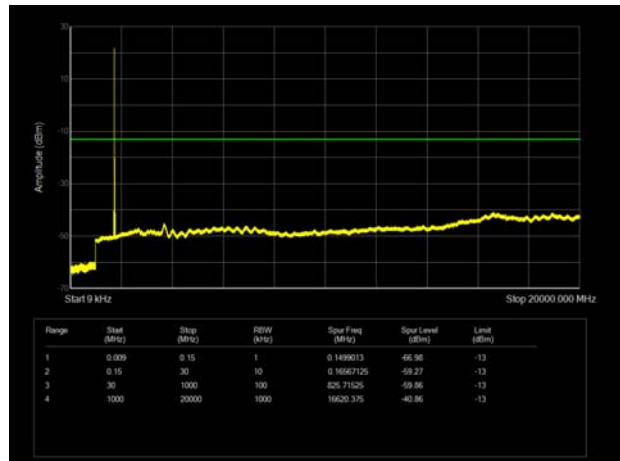

LTE Band 7 5MHz CH-Low 9kHz~20GHz

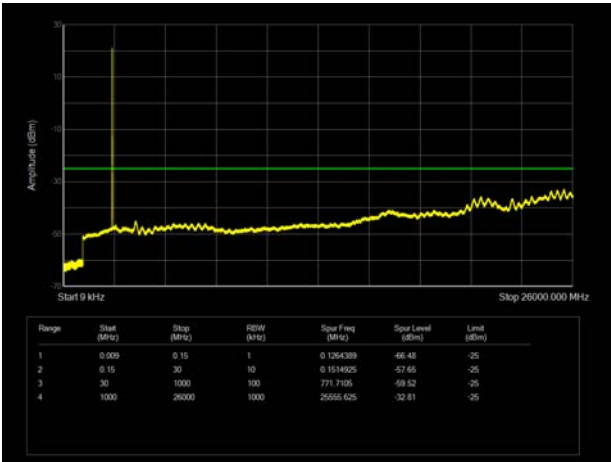

LTE Band 7 10MHz CH-Low 9kHz~20GHz

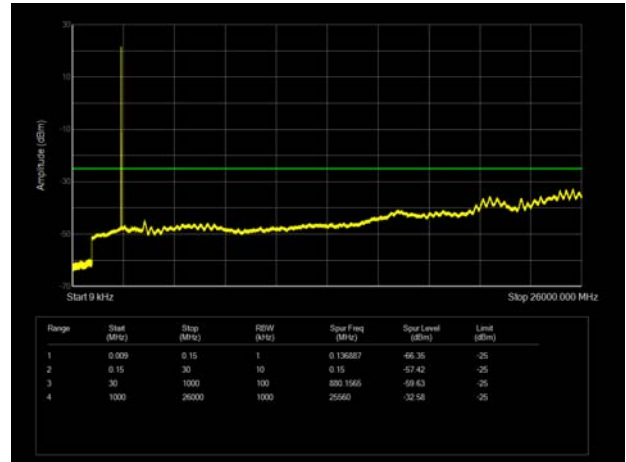

LTE Band 7 5MHz CH-Middle 9kHz~20GHz

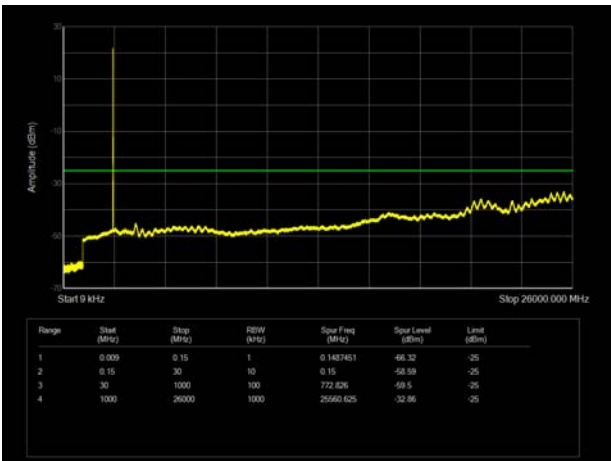

LTE Band 7 10MHz CH-Middle 9kHz~20GHz

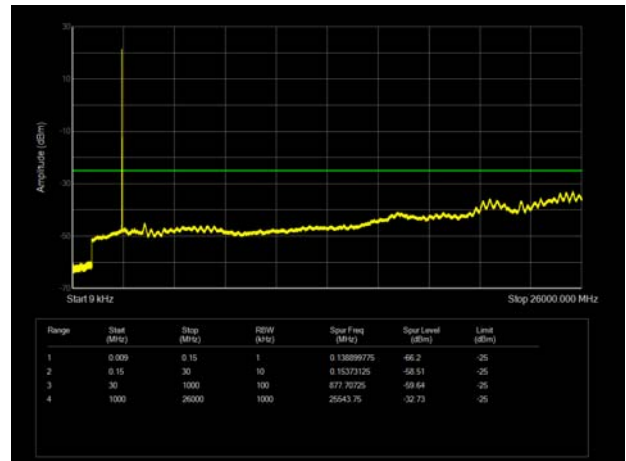

LTE Band 7 5MHz CH-High 9kHz~20GHz

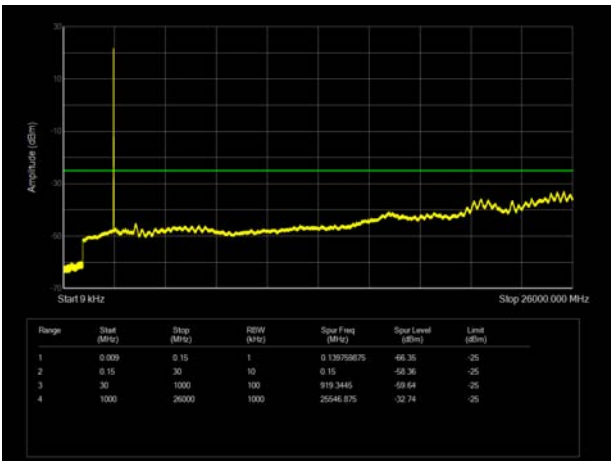

LTE Band 7 10MHz CH-High 9kHz~20GHz

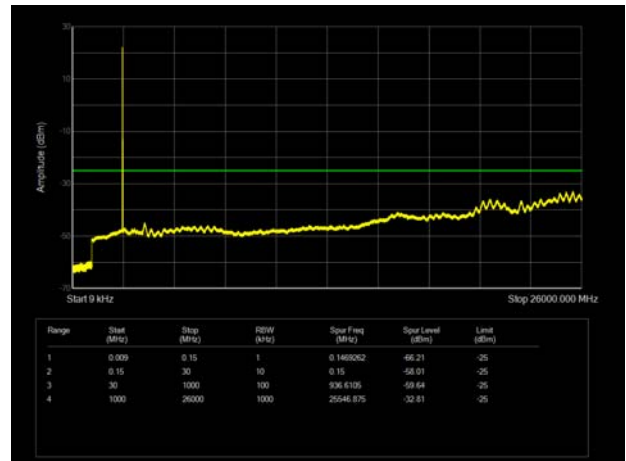

LTE Band 7 15MHz CH-Low 9kHz~20GHz

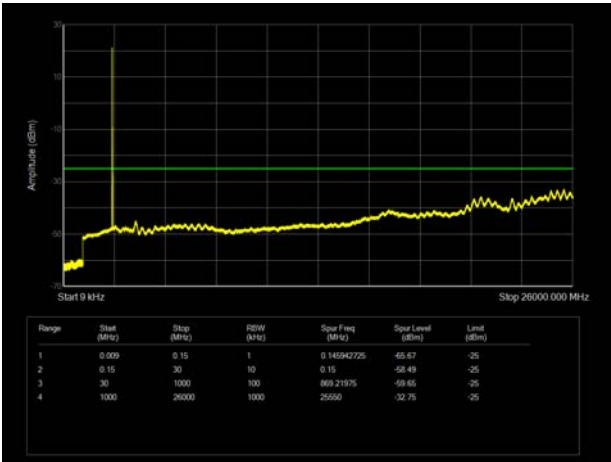

LTE Band 7 20MHz CH-Low 9kHz~20GHz

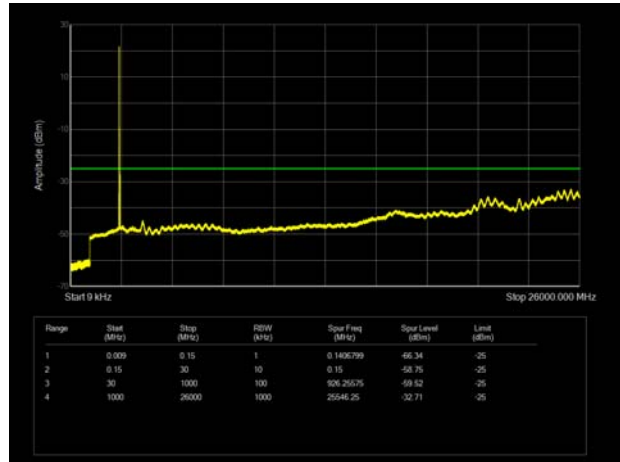

LTE Band 7 15MHz CH-Middle 9kHz~20GHz

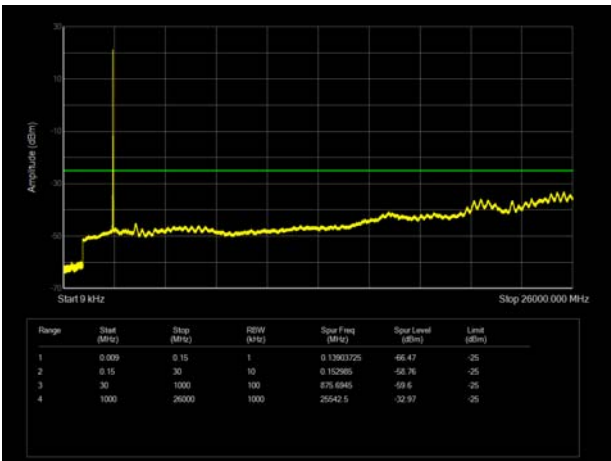

LTE Band 7 20MHz CH-Middle 9kHz~20GHz

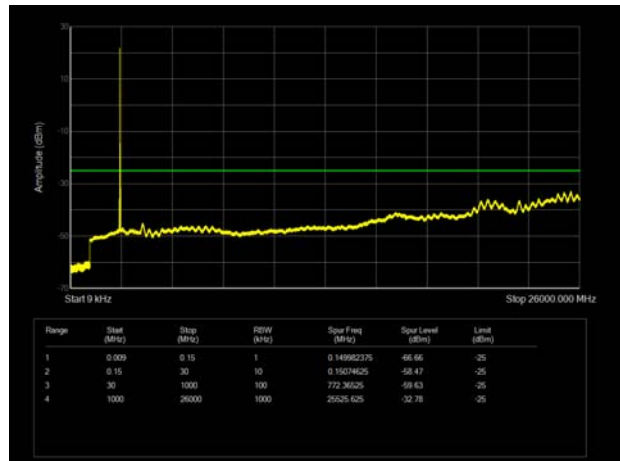

LTE Band 7 15MHz CH-High 9kHz~20GHz

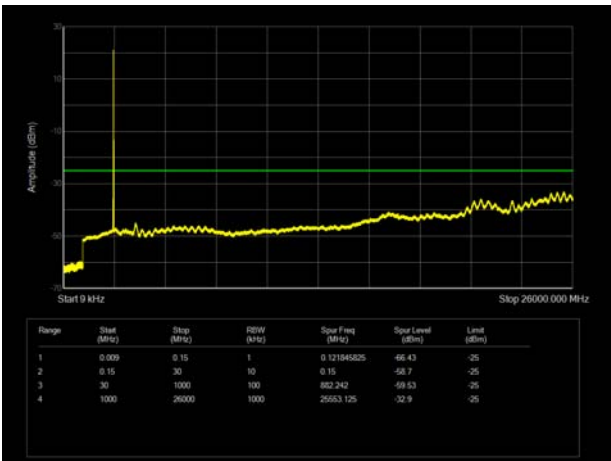

LTE Band 7 20MHz CH-High 9kHz~20GHz

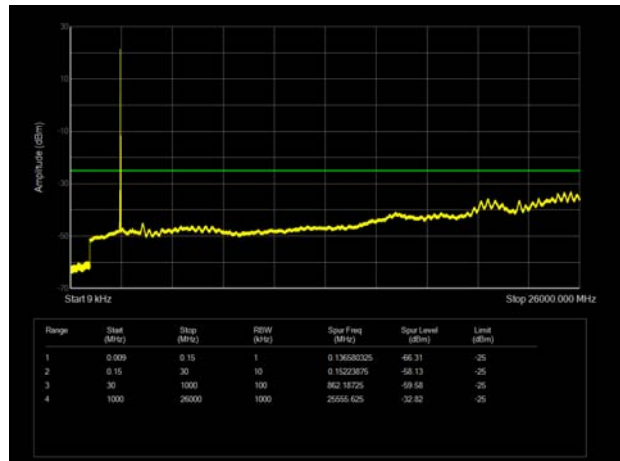

5.7 Radiates Spurious Emission

Ambient condition

Temperature	Relative humidity	Pressure
23°C ~25°C	45%~50%	101.5kPa

Method of Measurement

1. The testing follows FCC KDB 971168 D01 v03r01 Section 5.8 and ANSI C63.26 (2015).
2. Below 1GHz: The EUT is placed on a turntable 0.8 meters above the ground in the chamber, 3 meter away from the antenna. The maximal emission value is acquired by adjusting the antenna height, polarisation and turntable azimuth. Normally, the height range of antenna is 1 m to 4 m, the azimuth range of turntable is 0° to 360°, and the receive antenna has two polarizations Vertical (V) and Horizontal (H). Above 1GHz: (Note: the FCC's permission to use 1.5m as an alternative per TCBC Conf call of Dec. 2, 2014.) The EUT is placed on a turntable 1.5 meters above the ground in the chamber, 3 meter away from the antenna. The maximal emission value is acquired by adjusting the antenna height, polarisation and turntable azimuth. Normally, the height range of antenna is 1 m to 4 m, the azimuth range of turntable is 0° to 360°, and the receive antenna has two polarizations Vertical (V) and Horizontal (H).
3. A loop antenna, A log-periodic antenna or horn antenna shall be substituted in place of the EUT. The log-periodic antenna will be driven by a signal generator and the level will be adjusted till the same power value on the spectrum analyzer or receiver. The level of the spurious emissions can be calculated through the level of the signal generator, cable loss, the gain of the substitution antenna and the reading of the spectrum analyzer or receiver.
4. The EUT is then put into continuously transmitting mode at its maximum power level during the test. Set Test Receiver or Spectrum RBW=200Hz,VBW=600Hz for 9kHz150kHz , RBW=10kHz, VBW=30kHz 150kHz-30MHz ,RBW=100kHz,VBW=300kHz for 30MHz to 1GHz and RBW=1MHz, VBW=3MHz for above 1GHz And the maximum value of the receiver should be recorded as (Pr).
5. The EUT shall be replaced by a substitution antenna. In the chamber, an substitution antenna for the frequency band of interest is placed at the reference point of the chamber. An RF Signal source for the frequency band of interest is connected to the substitution antenna with a cable that has been constructed to not interfere with the radiation pattern of the antenna. A power (PMea) is applied to the input of the substitution antenna, and adjust the level of the signal generator output until the value of the receiver reach the previously recorded (Pr). The power of signal source (PMea) is recorded. The test should be performed by rotating the test item and adjusting the receiving antenna polarization.
6. A amplifier should be connected to the Signal Source output port. And the cable should be connect between the Amplifier and the Substitution Antenna. The cable loss (Pcl) ,the Substitution Antenna Gain (Ga) and the Amplifier Gain (PAg) should be recorded after test.
7. The measurement results are obtained as described below:

$$\text{Power(EIRP)} = \text{PMea} - \text{PAg} - \text{Pcl} + \text{Ga}$$

The measurement results are amend as described below:

$$\text{Power(EIRP)} = \text{PMea} - \text{Pcl} + \text{Ga}$$

8. This value is EIRP since the measurement is calibrated using an antenna of known gain (2.15 dBi) and known input power. ERP can be calculated from EIRP by subtracting the gain of the dipole, ERP

= EIRP-2.15dBi.

The modulation mode and RB allocation refer to section 5.1, using the maximum output power configuration.

Test setup

9KHz ~ 30MHz

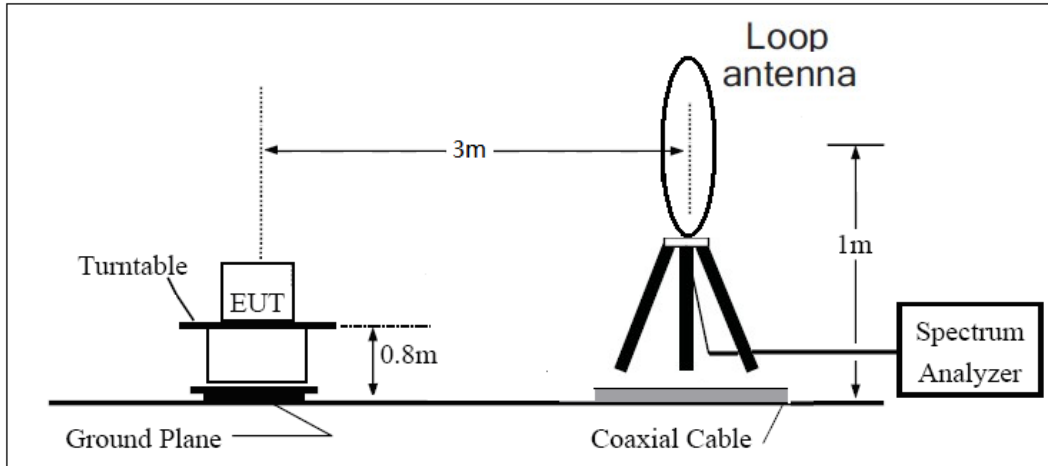

30MHz ~ 1GHz

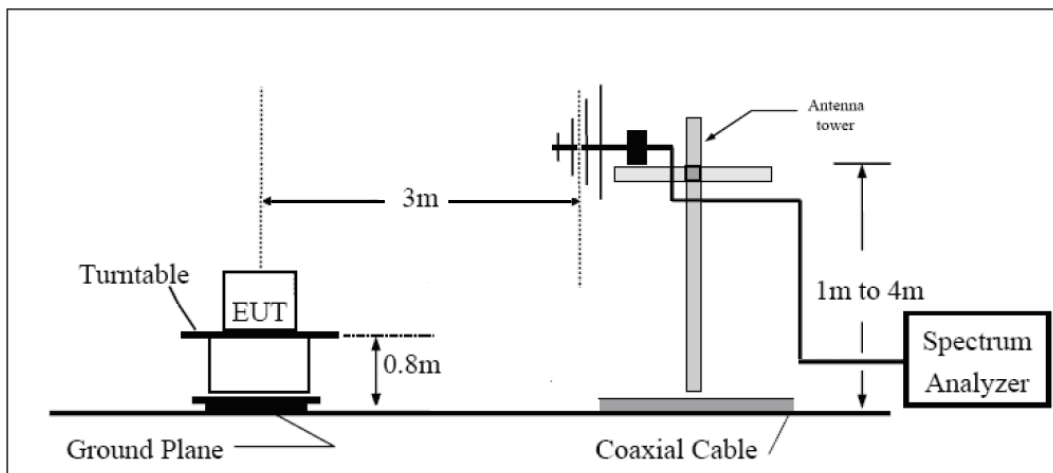

Above 1GHz

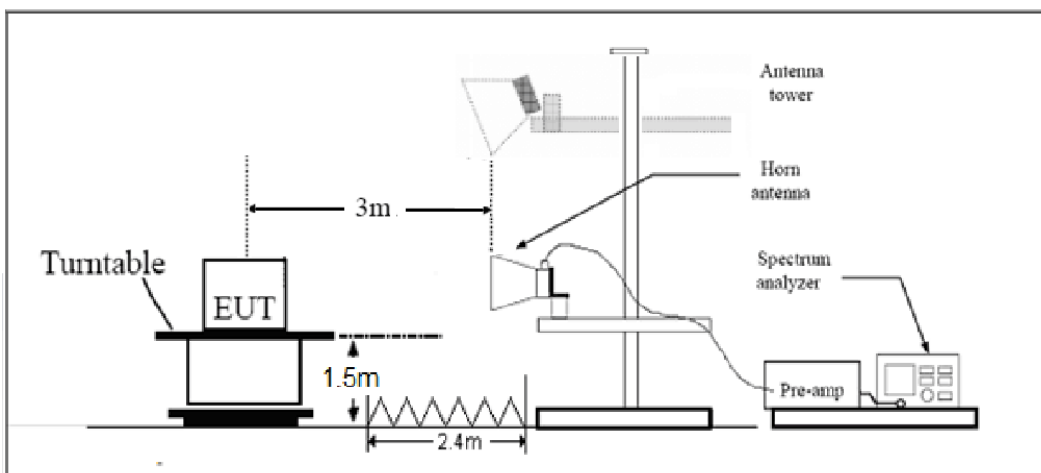

Note: Area side:2.4mX3.6m



Limits

Rule Part 27.53(h) specifies that “for operations in the 1695-1710 MHz, 1710-1755 MHz, 1755-1780 MHz, 1915-1920 MHz, 1995-2000 MHz, 2000-2020 MHz, 2110-2155 MHz, 2155-2180 MHz, and 2180-2200 bands, the power of any emission outside a licensee's frequency block shall be attenuated below the transmitter power (P) in watts by at least $43 + 10 \log_{10} (P)$ dB.”

Rule Part 27.53(m) $55 + 10 \log (P)$ dB on all frequencies more than X megahertz from the channel edge, where X is the greater of 6 megahertz or the actual emission bandwidth as defined in paragraph (m)(4) of this section.

Part 27.53 (h) Limit	-13 dBm
Part 27.53(m) Limit	-25 dBm

Measurement Uncertainty

The assessed measurement uncertainty to ensure 95% confidence level for the normal distribution is with the coverage factor $k = \pm 1.96$, $U = \pm 3.55$ dB.

**Test Result**

Sweep the whole frequency band through the range from 9kHz to the 10th harmonic of the carrier, the emissions below the noise floor will not be recorded in the report.

LTE Band 4 QPSK 1.4MHz CH-Middle, RB 1

Harmonic	Frequency (MHz)	SG (dBm)	Cable Loss (dB)	Gain (dBi)	Antenna Polarization	EIRP Level (dBm)	Limit (dBm)	Margin (dB)	Azimuth (deg)
2	3460.5	-61.40	2.6	10.75	Horizontal	-53.25	-13.00	40.25	90
3	5191.5	-61.46	2.4	11.05	Horizontal	-52.81	-13.00	39.81	45
4	6930.0	-66.20	4.5	11.15	Horizontal	-59.55	-13.00	46.55	315
5	8662.5	-66.50	5.1	11.35	Horizontal	-60.25	-13.00	47.25	180
6	10395.0	-63.00	5.3	11.95	Horizontal	-56.35	-13.00	43.35	0
7	12127.5	-63.81	5.5	13.55	Horizontal	-55.76	-13.00	42.76	45
8	13860.0	-61.95	6.3	13.75	Horizontal	-54.50	-13.00	41.50	180
9	15592.5	-63.75	6.7	13.85	Horizontal	-56.60	-13.00	43.60	135
10	17325.0	-60.08	6.8	14.25	Horizontal	-52.63	-13.00	39.63	270

Note: 1.The other Spurious RF Radiated emissions level is no more than noise floor.
2. The worst emission was found in the antenna is Horizontal position.

LTE Band 4 QPSK 5MHz CH-Middle, RB 1

Harmonic	Frequency (MHz)	SG (dBm)	Cable Loss (dB)	Gain (dBi)	Antenna Polarization	EIRP Level (dBm)	Limit (dBm)	Margin (dB)	Azimuth (deg)
2	3460.5	-61.23	2.6	10.75	Horizontal	-53.08	-13.00	40.08	90
3	5191.5	-60.40	2.4	11.05	Horizontal	-51.75	-13.00	38.75	0
4	6930.0	-66.86	4.5	11.15	Horizontal	-60.21	-13.00	47.21	45
5	8662.5	-66.02	5.1	11.35	Horizontal	-59.77	-13.00	46.77	180
6	10395.0	-62.18	5.3	11.95	Horizontal	-55.53	-13.00	42.53	135
7	12127.5	-64.33	5.5	13.55	Horizontal	-56.28	-13.00	43.28	315
8	13860.0	-62.02	6.3	13.75	Horizontal	-54.57	-13.00	41.57	90
9	15592.5	-64.03	6.7	13.85	Horizontal	-56.88	-13.00	43.88	135
10	17325.0	-61.18	6.8	14.25	Horizontal	-53.73	-13.00	40.73	0

Note: 1.The other Spurious RF Radiated emissions level is no more than noise floor.
2. The worst emission was found in the antenna is Horizontal position.



LTE Band 4 QPSK 20MHz CH-Middle, RB 1

Harmonic	Frequency (MHz)	SG (dBm)	Cable Loss (dB)	Gain (dBi)	Antenna Polarization	EIRP Level (dBm)	Limit (dBm)	Margin (dB)	Azimuth (deg)
2	3465.0	-52.78	2.6	10.75	Horizontal	-44.63	-13.00	31.63	180
3	5170.9	-55.75	2.4	11.05	Horizontal	-47.10	-13.00	34.10	135
4	6930.0	-58.85	4.5	11.15	Horizontal	-52.20	-13.00	39.20	90
5	8662.5	-53.05	5.1	11.35	Horizontal	-46.80	-13.00	33.80	0
6	10395.0	-46.55	5.3	11.95	Horizontal	-39.90	-13.00	26.90	0
7	12127.5	-51.05	5.5	13.55	Horizontal	-43.00	-13.00	30.00	45
8	13860.0	-49.45	6.3	13.75	Horizontal	-42.00	-13.00	29.00	90
9	15592.5	-49.65	6.7	13.85	Horizontal	-42.50	-13.00	29.50	225
10	17325.0	-45.75	6.8	14.25	Horizontal	-38.30	-13.00	25.30	135

Note: 1.The other Spurious RF Radiated emissions level is no more than noise floor.

2. The worst emission was found in the antenna is Horizontal position.

LTE Band 7 QPSK 5MHz CH-Middle, RB 1

Harmonic	Frequency (MHz)	SG (dBm)	Cable Loss (dB)	Gain (dBi)	Antenna Polarization	EIRP Level (dBm)	Limit (dBm)	Margin (dB)	Azimuth (deg)
2	5065.8	-53.47	2.00	9.15	Horizontal	-46.32	-25.00	21.32	45
3	7598.6	-65.16	2.50	11.35	Horizontal	-56.31	-25.00	31.31	90
4	10130.6	-59.96	4.20	12.05	Horizontal	-52.11	-25.00	27.11	315
5	12675.0	-63.75	5.20	12.85	Horizontal	-56.10	-25.00	31.10	0
6	15210.0	-63.56	5.50	14.23	Horizontal	-54.83	-25.00	29.83	135
7	17745.0	-62.34	5.70	14.15	Horizontal	-53.89	-25.00	28.89	180
8	20280.0	--	--	--	--	--	--	--	--
9	22815.0	--	--	--	--	--	--	--	--
10	25350.0	--	--	--	--	--	--	--	--

Note: 1.The other Spurious RF Radiated emissions level is no more than noise floor.

2. The worst emission was found in the antenna is Horizontal position.



LTE Band 7 QPSK 20MHz CH-Middle, RB 1

Harmonic	Frequency (MHz)	SG (dBm)	Cable Loss (dB)	Gain (dBi)	Antenna Polarization	EIRP Level (dBm)	Limit (dBm)	Margin (dB)	Azimuth (deg)
2	5052.4	-53.68	2.00	10.15	Horizontal	-45.53	-25.00	20.53	315
3	7605.0	-66.76	2.50	11.35	Horizontal	-57.91	-25.00	32.91	135
4	10140.0	-60.62	4.20	12.05	Horizontal	-52.77	-25.00	27.77	0
5	12675.0	-65.78	5.20	14.85	Horizontal	-56.13	-25.00	31.13	90
6	15210.0	-62.97	5.50	13.23	Horizontal	-55.24	-25.00	30.24	45
7	17745.0	-60.50	5.70	12.15	Horizontal	-54.05	-25.00	29.05	135
8	20280.0	--	--	--	--	--	--	--	--
9	22815.0	--	--	--	--	--	--	--	--
10	25350.0	--	--	--	--	--	--	--	--

Note: 1. The other Spurious RF Radiated emissions level is no more than noise floor.

2. The worst emission was found in the antenna is Horizontal position.



6 Main Test Instruments

Name	Manufacturer	Type	Serial Number	Calibration Date	Expiration Date
Base Station Simulator	R&S	CMW500	113824	2019-05-19	2020-05-18
Power Splitter	Hua Xiang	SHX-GF2-2-13	10120101	/	/
Spectrum Analyzer	Key sight	N9010A	MY50210259	2019-05-19	2020-05-18
Signal Analyzer	R&S	FSV30	100815	2018-12-16	2019-12-15
Loop Antenna	SCHWARZBECK	FMZB1519	1519-047	2017-09-26	2020-09-25
Trilog Antenna	SCHWARZBECK	VUBL 9163	9163-201	2017-11-18	2020-11-17
Horn Antenna	R&S	HF907	100126	2018-07-07	2020-07-06
Horn Antenna	ETS-Lindgren	3160-09	00102643	2018-06-20	2020-06-19
Signal generator	R&S	SMB 100A	102594	2019-05-19	2020-05-18
Climatic Chamber	ESPEC	SU-242	93000506	2017-12-17	2020-12-16
Preamplifier	R&S	SCU18	102327	2019-05-19	2020-05-18
MOB COMMS DC SUPPLY	Keysight	66319D	MY43004105	2019-05-19	2020-05-18
RF Cable	Agilent	SMA 15cm	0001	2019-06-14	2019-12-13
Software	R&S	EMC32	9.26.0	/	/

*****END OF REPORT *****