



RF TEST REPORT

Applicant Shanghai Sunmi Technology Co.,Ltd.
FCC ID 2AH25T1711
Product POS system
Brand SUNMI
Model T1711
Report No. R1911A0661-R1V1
Issue Date December 31, 2019

TA Technology (Shanghai) Co., Ltd. tested the above equipment in accordance with the requirements in **FCC CFR47 Part 2 (2018)/ FCC CFR 47 Part 22H (2018)**. The test results show that the equipment tested is capable of demonstrating compliance with the requirements as documented in this report.

Performed by: Peng Tao

Approved by: Kai Xu

TA Technology (Shanghai) Co., Ltd.

No.145, Jintang Rd, Tangzhen Industry Park, Pudong Shanghai, China

TEL: +86-021-50791141/2/3

FAX: +86-021-50791141/2/3-8000



TABLE OF CONTENT

1. Test Laboratory	4
1.1. Notes of the Test Report	4
1.2. Test facility	4
1.3. Testing Location	4
2. General Description of Equipment under Test.....	5
2.1. Applicant and Manufacturer Information	5
2.2. General Information.....	5
3. Applied Standards	7
4. Test Configuration.....	8
5. Test Case Results.....	10
5.1. RF Power Output and Effective Radiated Power	10
5.2. Occupied Bandwidth	17
5.3. Band Edge Compliance.....	26
5.4. Peak-to-Average Power Ratio (PAPR)	34
5.5. Frequency Stability.....	37
5.6. Spurious Emissions at Antenna Terminals	42
5.7. Radiates Spurious Emission	51
6. Main Test Instruments	57



Summary of measurement results

No.	Test Case	Clause in FCC rules	Verdict
1	RF power output and Effective Radiated Power	2.1046 22.913(a)(5)	PASS
2	Occupied Bandwidth	2.1049	PASS
3	Band Edge Compliance	2.1051 / 22.917(a)	PASS
4	Peak-to-Average Power Ratio	22.913(d)/ KDB 971168 D01(5.7)	PASS
5	Frequency Stability	2.1055 / 22.355	PASS
6	Spurious Emissions at Antenna Terminals	2.1051 / 22.917(a)	PASS
7	Radiates Spurious Emission	2.1053 / 22.917 (a)	PASS

Date of Testing: November 13, 2019~ December 2, 2019



1. Test Laboratory

1.1. Notes of the Test Report

This report shall not be reproduced in full or partial, without the written approval of **TA technology (shanghai) co., Ltd.** The results documented in this report apply only to the tested sample, under the conditions and modes of operation as described herein .Measurement Uncertainties were not taken into account and are published for informational purposes only. This report is written to support regulatory compliance of the applicable standards stated above.

1.2. Test facility

FCC (Designation number: CN1179, Test Firm Registration Number: 446626)

TA Technology (Shanghai) Co., Ltd. has been listed on the US Federal Communications Commission list of test facilities recognized to perform electromagnetic emissions measurements.

1.3. Testing Location

Company: TA Technology (Shanghai) Co., Ltd.
Address: No.145, Jintang Rd, Tangzhen Industry Park, Pudong
City: Shanghai
Post code: 201201
Country: P. R. China
Contact: Xu Kai
Telephone: +86-021-50791141/2/3
Fax: +86-021-50791141/2/3-8000
Website: <http://www.ta-shanghai.com>
E-mail: xukai@ta-shanghai.com

2. General Description of Equipment under Test

2.1. Applicant and Manufacturer Information

Applicant	Shanghai Sunmi Technology Co.,Ltd.
Applicant address	Room 505, KIC Plaza, No.388 Song Hu Road, Yang Pu District, Shanghai, China
Manufacturer	Shanghai Sunmi Technology Co.,Ltd.
Manufacturer address	Room 505, KIC Plaza, No.388 Song Hu Road, Yang Pu District, Shanghai, China

2.2. General Information

EUT Description			
Model	T1711		
SN	DM03D9940005		
Hardware Version	D2MMB60C		
Software Version	V1.0.10		
Power Supply	AC adapter		
Antenna Type	Internal Antenna		
Antenna Gain	0.21dBi		
Test Mode(s)	GSM 850; WCDMA Band V;LTE Band 5;		
Test Modulation	(GSM)GMSK,8PSK; (WCDMA) BPSK, QPSK; (LTE)QPSK 16QAM;		
GPRS Multislot Class	33		
EGPRS Multislot Class	33		
HSDPA UE Category	14		
HSUPA UE Category	6		
DC-HSDPA UE Category	24		
LTE Category	4		
Maximum E.R.P.	GSM 850:	30.00dBm	
	WCDMA Band V:	20.57dBm	
	LTE Band 5:	21.26dBm	
Rated Power Supply Voltage	24V		
Extreme Voltage	Minimum: 22.8V Maximum: 25.2V		
Extreme Temperature	Lowest: -20°C Highest: +60°C		
Operating Frequency Range(s)	Band	Tx (MHz)	Rx (MHz)
	GSM850	824 ~ 849	869 ~ 894
	WCDMA Band V	824 ~ 849	869 ~ 894
	LTE Band 5	824 ~ 849	869 ~ 894



EUT Accessory	
Adapter	Manufacturer: Jiangsu Chenyang Electron Co.,Ltd. Model: CYSE65-240250
Note: The information of the EUT is declared by the manufacturer.	



3. Applied Standards

According to the specifications of the manufacturer, it must comply with the requirements of the following standards:

Test standards:

FCC CFR 47 Part 22H (2018)

ANSI C63.26 (2015)

Reference standard:

FCC CFR47 Part 2 (2018)

KDB 971168 D01 Power Meas License Digital Systems v03r01

4. Test Configuration

Radiated measurements are performed by rotating the EUT in three different orthogonal test planes. EUT stand-up position (Z axis), lie-down position (X, Y axis). Receiver antenna polarization (horizontal and vertical), the worst emission was found in position (X axis, vertical polarization) and the worst case was recorded.

All mode and data rates and positions were investigated. Subsequently, only the worst case emissions are reported.

The following testing in GSM/WCDMA/LTE is set based on the maximum RF Output Power.

Test modes are chosen to be reported as the worst case configuration below:

Test items	Modes/Modulation	
	GSM 850	WCDMA Band V
RF power output and Effective Isotropic Radiated power	GPRS EGPRS	RMC HSDPA/HSUPA DC-HSDPA
Occupied Bandwidth	GPRS(1Tx slot) EGPRS(1Tx slot)	RMC
Band Edge Compliance	GPRS(1Tx slot) EGPRS(1Tx slot)	RMC
Peak-to-Average Power Ratio	GPRS(1Tx slot) EGPRS(1Tx slot)	RMC
Frequency Stability	GPRS(1Tx slot) EGPRS(1Tx slot)	RMC
Spurious Emissions at Antenna Terminals	GPRS(1Tx slot)	RMC
Radiates Spurious Emission	GPRS(1Tx slot)	RMC

Test modes are chosen as the worst case configuration below for LTE Band 5.

Test items	Bandwidth (MHz)				Modulation		RB			Test Channel		
	1.4	3	5	10	QPSK	16QAM	1	50%	100%	L	M	H
RF power output and Effective Isotropic Radiated power	O	O	O	O	O	O	O	O	O	O	O	O
Occupied Bandwidth	O	O	O	O	O	O	-	-	O	-	O	-
Band Edge Compliance	O	O	O	O	O	O	O	-	O	O	-	O
Peak-to-Average Power Ratio	O	O	O	O	O	O	-	-	O	O	O	O
Frequency Stability	O	O	O	O	O	O	-	-	O	-	O	-
Spurious Emissions at Antenna Terminals	O	O	O	O	O	-	O	-	-	O	O	O
Radiates Spurious Emission	O	-	O	O	O	-	O	-	-	-	O	-
Note	1. The mark "O" means that this configuration is chosen for testing. 2. The mark "-" means that this configuration is not testing.											

5. Test Case Results

5.1. RF Power Output and Effective Radiated Power

Ambient condition

Temperature	Relative humidity	Pressure
23°C ~25°C	45%~50%	101.5kPa

Methods of Measurement

During the process of the testing, The EUT is controlled by the Base Station Simulator to ensure max power transmission and proper modulation.

The testing follows FCC KDB 971168 v03r01 Section 5.8 and ANSI C63.26 (2015).

a) Connect the equipment as illustrated. Mount the equipment with the manufacturer specified antenna in a vertical orientation on a manufacturer specified mounting surface located on a non-conducting rotating platform of a RF anechoic chamber (preferred) or a standard radiation site.

b) Key the transmitter, then rotate the EUT 360° azimuthally and record spectrum analyzer power level (LVL) measurements at angular increments that are sufficiently small to permit resolution of all peaks. If a standard radiation test site is used, raise and lower the test antenna to obtain a maximum reading at each angular increment. (Note: several batteries may be needed to offset the effect of battery voltage droop, which should not exceed 5% of the manufactured specified battery voltage during transmission).

c) Replace the transmitter under test with a vertically polarized half-wave dipole (or an antenna whose gain is known relative to an ideal half-wave dipole). The center of the antenna should be at the same location as the center of the antenna under test.

d) Connect the antenna to a signal generator with a known output power and record the path loss (in dB) as LOSS. If a standard radiation test site is used, raise and lower the test antenna to obtain a maximum reading. $LOSS = \text{Generator Output Power (dBm)} - \text{Analyzer reading (dBm)}$

e) Determine the effective radiated output power at each angular position from the readings in steps b) and d) using the following equation: $ERP \text{ (dBm)} = \text{LVL (dBm)} + \text{LOSS (dB)}$

f) The maximum ERP is the maximum value determined in the preceding step.

g) When calculating ERP, in addition to knowing the antenna radiation and matching characteristics, it is necessary to know the loss values of all elements (e.g. transmission line attenuation, mismatches, filters, combiners) interposed between the point where transmitter output power is measured, and the point where power is applied to the antenna. ERP can then be calculated as follows:

$$EIRP \text{ (dBm)} = \text{Output Power (dBm)} - \text{Losses (dB)} + \text{Antenna Gain (dBi)}$$

where: dBd refers to gain relative to an ideal dipole.

$$EIRP \text{ (dBm)} = ERP \text{ (dBm)} + 2.15 \text{ (dB.)}$$

The RB allocation refers to section 5.1, using the maximum output power configuration.

Test Setup

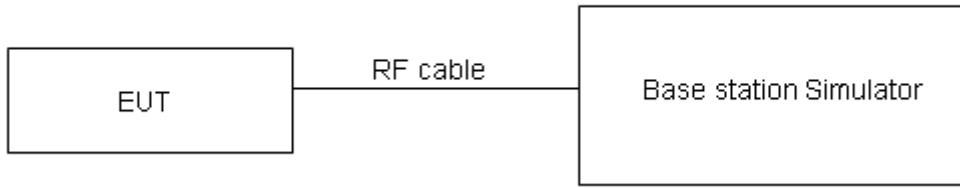

The loss between RF output port of the EUT and the input port of the tester has been taken into consideration.

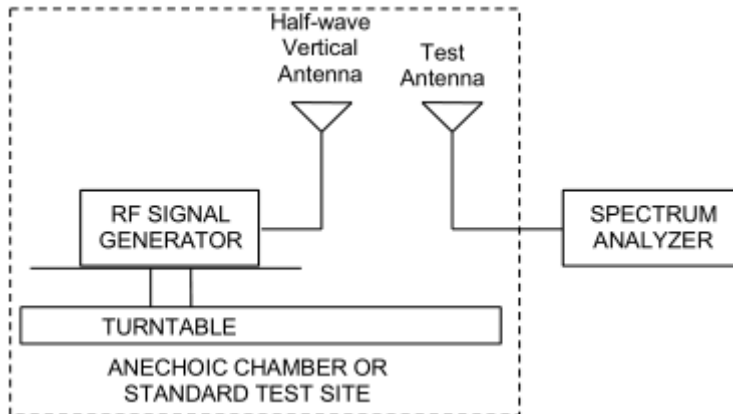
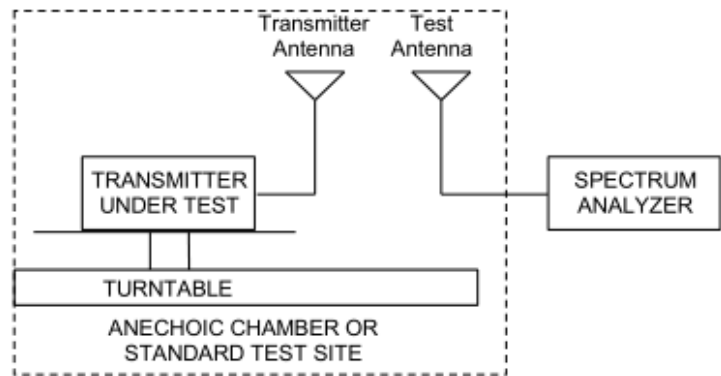

Limits

No specific RF power output requirements in part 2.1046.

Rule Part 22.913(a)(5) specifies that "Mobile/portable stations are limited to 7 watts ERP".

Limit	$\leq 7 \text{ W}$ (38.45 dBm)
-------	--------------------------------

Measurement Uncertainty

The assessed measurement uncertainty to ensure 95% confidence level for the normal distribution is with the coverage factor $k = 2$, $U = 0.4 \text{ dB}$ for RF power output, $k = 2$, $U = 1.19 \text{ dB}$ for ERP .

Test Results

GSM 850		Conducted Power (dBm)			ERP (dBm)		
		Channel 128	Channel 190	Channel 251	Channel 128	Channel 190	Channel 251
		824.2 (MHz)	836.6 (MHz)	848.8 (MHz)	824.2 (MHz)	836.6 (MHz)	848.8 (MHz)
GPRS/EGPRS (GMSK)	1TXslot	31.94	31.62	31.89	30.00	29.68	29.95
	2TXslots	31.71	31.48	31.74	29.77	29.54	29.80
	3TXslots	29.50	29.25	29.15	27.56	27.31	27.21
	4TXslots	28.37	27.86	28.08	26.43	25.92	26.14
EGPRS (8PSK)	1TXslot	26.14	26.09	26.02	24.20	24.15	24.08
	2TXslots	25.98	25.96	25.85	24.04	24.02	23.91
	3TXslots	25.75	25.84	25.71	23.81	23.90	23.77
	4TXslots	25.58	25.76	25.46	23.64	23.82	23.52

WCDMA Band V		Conducted Power (dBm)			ERP (dBm)		
		Channel 4132	Channel 4183	Channel 4233	Channel 4132	Channel 4183	Channel 4233
		826.4 (MHz)	836.6 (MHz)	846.6 (MHz)	826.4 (MHz)	836.6 (MHz)	846.6 (MHz)
RMC		22.51	22.32	22.41	20.57	20.38	20.47
HSDPA	Sub - Test 1	21.97	21.74	21.85	20.03	19.80	19.91
	Sub - Test 2	21.96	21.76	21.82	20.02	19.82	19.88
	Sub - Test 3	21.43	21.26	21.34	19.49	19.32	19.40
	Sub - Test 4	21.44	21.27	21.32	19.50	19.33	19.38
HSUPA	Sub - Test 1	21.93	21.73	21.80	19.99	19.79	19.86
	Sub - Test 2	20.92	20.71	20.79	18.98	18.77	18.85
	Sub - Test 3	21.39	21.19	21.28	19.45	19.25	19.34
	Sub - Test 4	20.85	20.68	20.76	18.91	18.74	18.82
	Sub - Test 5	21.86	21.66	21.74	19.92	19.72	19.80
DC-HSDPA	Sub - Test 1	21.85	21.68	21.75	19.91	19.74	19.81
	Sub - Test 2	21.84	21.67	21.74	19.90	19.73	19.80
	Sub - Test 3	21.42	21.16	21.25	19.48	19.22	19.31
	Sub - Test 4	21.41	21.15	21.24	19.47	19.21	19.30



Band	Bandwidth (MHz)	UL Channel	RB Size	RB Position	Modulation	Power (dBm)	ERP
LTE Band5	1.4	20407	1	#0	QPSK	23.15	21.21
LTE Band5	1.4	20407	1	#Mid	QPSK	23.19	21.25
LTE Band5	1.4	20407	1	#Max	QPSK	23.06	21.12
LTE Band5	1.4	20407	3	#0	QPSK	22.90	20.96
LTE Band5	1.4	20407	3	#Mid	QPSK	22.90	20.96
LTE Band5	1.4	20407	3	#Max	QPSK	22.92	20.98
LTE Band5	1.4	20407	6	#0	QPSK	21.96	20.02
LTE Band5	1.4	20407	1	#0	QAM16	22.01	20.07
LTE Band5	1.4	20407	1	#Mid	QAM16	22.22	20.28
LTE Band5	1.4	20407	1	#Max	QAM16	22.14	20.20
LTE Band5	1.4	20407	3	#0	QAM16	21.88	19.94
LTE Band5	1.4	20407	3	#Mid	QAM16	21.89	19.95
LTE Band5	1.4	20407	3	#Max	QAM16	21.64	19.70
LTE Band5	1.4	20407	6	#0	QAM16	20.88	18.94
LTE Band5	1.4	20525	1	#0	QPSK	23.09	21.15
LTE Band5	1.4	20525	1	#Mid	QPSK	23.18	21.24
LTE Band5	1.4	20525	1	#Max	QPSK	22.98	21.04
LTE Band5	1.4	20525	3	#0	QPSK	22.93	20.99
LTE Band5	1.4	20525	3	#Mid	QPSK	22.92	20.98
LTE Band5	1.4	20525	3	#Max	QPSK	23.10	21.16
LTE Band5	1.4	20525	6	#0	QPSK	22.15	20.21
LTE Band5	1.4	20525	1	#0	QAM16	22.56	20.62
LTE Band5	1.4	20525	1	#Mid	QAM16	22.56	20.62
LTE Band5	1.4	20525	1	#Max	QAM16	22.51	20.57
LTE Band5	1.4	20525	3	#0	QAM16	22.04	20.10
LTE Band5	1.4	20525	3	#Mid	QAM16	22.03	20.09
LTE Band5	1.4	20525	3	#Max	QAM16	22.24	20.30
LTE Band5	1.4	20525	6	#0	QAM16	21.11	19.17
LTE Band5	1.4	20643	1	#0	QPSK	22.76	20.82
LTE Band5	1.4	20643	1	#Mid	QPSK	23.20	21.26
LTE Band5	1.4	20643	1	#Max	QPSK	23.18	21.24
LTE Band5	1.4	20643	3	#0	QPSK	22.88	20.94
LTE Band5	1.4	20643	3	#Mid	QPSK	22.87	20.93
LTE Band5	1.4	20643	3	#Max	QPSK	22.91	20.97
LTE Band5	1.4	20643	6	#0	QPSK	21.93	19.99
LTE Band5	1.4	20643	1	#0	QAM16	21.75	19.81
LTE Band5	1.4	20643	1	#Mid	QAM16	22.12	20.18
LTE Band5	1.4	20643	1	#Max	QAM16	21.78	19.84
LTE Band5	1.4	20643	3	#0	QAM16	22.21	20.27
LTE Band5	1.4	20643	3	#Mid	QAM16	22.20	20.26



LTE Band5	1.4	20643	3	#Max	QAM16	22.27	20.33
LTE Band5	1.4	20643	6	#0	QAM16	20.81	18.87
LTE Band5	3	20415	1	#0	QPSK	22.78	20.84
LTE Band5	3	20415	1	#Mid	QPSK	22.75	20.81
LTE Band5	3	20415	1	#Max	QPSK	23.03	21.09
LTE Band5	3	20415	8	#0	QPSK	21.93	19.99
LTE Band5	3	20415	8	#Mid	QPSK	21.95	20.01
LTE Band5	3	20415	8	#Max	QPSK	21.97	20.03
LTE Band5	3	20415	15	#0	QPSK	22.05	20.11
LTE Band5	3	20415	1	#0	QAM16	21.79	19.85
LTE Band5	3	20415	1	#Mid	QAM16	21.54	19.60
LTE Band5	3	20415	1	#Max	QAM16	21.49	19.55
LTE Band5	3	20415	8	#0	QAM16	21.27	19.33
LTE Band5	3	20415	8	#Mid	QAM16	21.28	19.34
LTE Band5	3	20415	8	#Max	QAM16	20.77	18.83
LTE Band5	3	20415	15	#0	QAM16	20.93	18.99
LTE Band5	3	20525	1	#0	QPSK	22.78	20.84
LTE Band5	3	20525	1	#Mid	QPSK	23.07	21.13
LTE Band5	3	20525	1	#Max	QPSK	22.68	20.74
LTE Band5	3	20525	8	#0	QPSK	21.83	19.89
LTE Band5	3	20525	8	#Mid	QPSK	21.82	19.88
LTE Band5	3	20525	8	#Max	QPSK	22.17	20.23
LTE Band5	3	20525	15	#0	QPSK	21.96	20.02
LTE Band5	3	20525	1	#0	QAM16	22.09	20.15
LTE Band5	3	20525	1	#Mid	QAM16	22.40	20.46
LTE Band5	3	20525	1	#Max	QAM16	22.51	20.57
LTE Band5	3	20525	8	#0	QAM16	20.68	18.74
LTE Band5	3	20525	8	#Mid	QAM16	20.68	18.74
LTE Band5	3	20525	8	#Max	QAM16	20.83	18.89
LTE Band5	3	20525	15	#0	QAM16	20.49	18.55
LTE Band5	3	20635	1	#0	QPSK	22.65	20.71
LTE Band5	3	20635	1	#Mid	QPSK	22.88	20.94
LTE Band5	3	20635	1	#Max	QPSK	23.01	21.07
LTE Band5	3	20635	8	#0	QPSK	21.74	19.80
LTE Band5	3	20635	8	#Mid	QPSK	21.76	19.82
LTE Band5	3	20635	8	#Max	QPSK	21.81	19.87
LTE Band5	3	20635	15	#0	QPSK	21.63	19.69
LTE Band5	3	20635	1	#0	QAM16	21.70	19.76
LTE Band5	3	20635	1	#Mid	QAM16	21.63	19.69
LTE Band5	3	20635	1	#Max	QAM16	21.68	19.74
LTE Band5	3	20635	8	#0	QAM16	20.54	18.60
LTE Band5	3	20635	8	#Mid	QAM16	20.56	18.62
LTE Band5	3	20635	8	#Max	QAM16	21.05	19.11



LTE Band5	3	20635	15	#0	QAM16	20.68	18.74
LTE Band5	5	20425	1	#0	QPSK	22.82	20.88
LTE Band5	5	20425	1	#Mid	QPSK	22.67	20.73
LTE Band5	5	20425	1	#Max	QPSK	22.47	20.53
LTE Band5	5	20425	12	#0	QPSK	21.80	19.86
LTE Band5	5	20425	12	#Mid	QPSK	21.82	19.88
LTE Band5	5	20425	12	#Max	QPSK	21.77	19.83
LTE Band5	5	20425	25	#0	QPSK	21.77	19.83
LTE Band5	5	20425	1	#0	QAM16	21.56	19.62
LTE Band5	5	20425	1	#Mid	QAM16	21.47	19.53
LTE Band5	5	20425	1	#Max	QAM16	21.18	19.24
LTE Band5	5	20425	12	#0	QAM16	20.82	18.88
LTE Band5	5	20425	12	#Mid	QAM16	20.76	18.82
LTE Band5	5	20425	12	#Max	QAM16	20.64	18.70
LTE Band5	5	20425	25	#0	QAM16	20.90	18.96
LTE Band5	5	20525	1	#0	QPSK	22.59	20.65
LTE Band5	5	20525	1	#Mid	QPSK	22.68	20.74
LTE Band5	5	20525	1	#Max	QPSK	22.46	20.52
LTE Band5	5	20525	12	#0	QPSK	21.73	19.79
LTE Band5	5	20525	12	#Mid	QPSK	21.79	19.85
LTE Band5	5	20525	12	#Max	QPSK	21.77	19.83
LTE Band5	5	20525	25	#0	QPSK	21.64	19.70
LTE Band5	5	20525	1	#0	QAM16	21.76	19.82
LTE Band5	5	20525	1	#Mid	QAM16	22.10	20.16
LTE Band5	5	20525	1	#Max	QAM16	22.06	20.12
LTE Band5	5	20525	12	#0	QAM16	20.46	18.52
LTE Band5	5	20525	12	#Mid	QAM16	20.46	18.52
LTE Band5	5	20525	12	#Max	QAM16	20.60	18.66
LTE Band5	5	20525	25	#0	QAM16	20.50	18.56
LTE Band5	5	20625	1	#0	QPSK	22.82	20.88
LTE Band5	5	20625	1	#Mid	QPSK	22.65	20.71
LTE Band5	5	20625	1	#Max	QPSK	22.69	20.75
LTE Band5	5	20625	12	#0	QPSK	21.57	19.63
LTE Band5	5	20625	12	#Mid	QPSK	21.60	19.66
LTE Band5	5	20625	12	#Max	QPSK	21.63	19.69
LTE Band5	5	20625	25	#0	QPSK	21.68	19.74
LTE Band5	5	20625	1	#0	QAM16	21.50	19.56
LTE Band5	5	20625	1	#Mid	QAM16	21.32	19.38
LTE Band5	5	20625	1	#Max	QAM16	21.41	19.47
LTE Band5	5	20625	12	#0	QAM16	20.48	18.54
LTE Band5	5	20625	12	#Mid	QAM16	20.43	18.49
LTE Band5	5	20625	12	#Max	QAM16	20.68	18.74
LTE Band5	5	20625	25	#0	QAM16	20.46	18.52



LTE Band5	10	20450	1	#0	QPSK	22.88	20.94
LTE Band5	10	20450	1	#Mid	QPSK	22.64	20.70
LTE Band5	10	20450	1	#Max	QPSK	22.47	20.53
LTE Band5	10	20450	25	#0	QPSK	21.75	19.81
LTE Band5	10	20450	25	#Mid	QPSK	21.77	19.83
LTE Band5	10	20450	25	#Max	QPSK	21.59	19.65
LTE Band5	10	20450	50	#0	QPSK	21.67	19.73
LTE Band5	10	20450	1	#0	QAM16	21.62	19.68
LTE Band5	10	20450	1	#Mid	QAM16	21.08	19.14
LTE Band5	10	20450	1	#Max	QAM16	21.08	19.14
LTE Band5	10	20450	25	#0	QAM16	20.88	18.94
LTE Band5	10	20450	25	#Mid	QAM16	20.84	18.90
LTE Band5	10	20450	25	#Max	QAM16	20.54	18.60
LTE Band5	10	20450	50	#0	QAM16	20.69	18.75
LTE Band5	10	20525	1	#0	QPSK	22.51	20.57
LTE Band5	10	20525	1	#Mid	QPSK	22.90	20.96
LTE Band5	10	20525	1	#Max	QPSK	22.82	20.88
LTE Band5	10	20525	25	#0	QPSK	21.64	19.70
LTE Band5	10	20525	25	#Mid	QPSK	21.63	19.69
LTE Band5	10	20525	25	#Max	QPSK	21.79	19.85
LTE Band5	10	20525	50	#0	QPSK	21.57	19.63
LTE Band5	10	20525	1	#0	QAM16	22.04	20.10
LTE Band5	10	20525	1	#Mid	QAM16	22.25	20.31
LTE Band5	10	20525	1	#Max	QAM16	22.34	20.40
LTE Band5	10	20525	25	#0	QAM16	20.54	18.60
LTE Band5	10	20525	25	#Mid	QAM16	20.54	18.60
LTE Band5	10	20525	25	#Max	QAM16	20.83	18.89
LTE Band5	10	20525	50	#0	QAM16	20.43	18.49
LTE Band5	10	20600	1	#0	QPSK	22.81	20.87
LTE Band5	10	20600	1	#Mid	QPSK	22.55	20.61
LTE Band5	10	20600	1	#Max	QPSK	22.52	20.58
LTE Band5	10	20600	25	#0	QPSK	21.55	19.61
LTE Band5	10	20600	25	#Mid	QPSK	21.60	19.66
LTE Band5	10	20600	25	#Max	QPSK	21.68	19.74
LTE Band5	10	20600	50	#0	QPSK	21.74	19.80
LTE Band5	10	20600	1	#0	QAM16	21.67	19.73
LTE Band5	10	20600	1	#Mid	QAM16	21.09	19.15
LTE Band5	10	20600	1	#Max	QAM16	20.97	19.03
LTE Band5	10	20600	25	#0	QAM16	20.71	18.77
LTE Band5	10	20600	25	#Mid	QAM16	20.75	18.81
LTE Band5	10	20600	25	#Max	QAM16	20.57	18.63
LTE Band5	10	20600	50	#0	QAM16	20.64	18.70

5.2. Occupied Bandwidth

Ambient condition

Temperature	Relative humidity	Pressure
23°C ~25°C	45%~50%	101.5kPa

Method of Measurement

The EUT was connected to Spectrum Analyzer and Base Station Simulator via power Splitter. The occupied bandwidth is measured using spectrum analyzer.

RBW is set to 3kHz, VBW is set to 10kHz for GSM 850,

RBW is set to 51kHz, VBW is set to 160kHz for WCDMA Band V,

RBW is set to 30 kHz, VBW is set to 91kHz for LTE Band 5 (1.4MHz),

RBW is set to 62 kHz, VBW is set to 180 kHz for LTE Band 5 (3MHz),

RBW is set to 100 kHz, VBW is set to 300 kHz for LTE Band 5 (5MHz),

RBW is set to 200 kHz, VBW is set to 620kHz for LTE Band 5 (10MHz),

99% power and -26dBc occupied bandwidths are recorded. Spectrum analyzer plots are included on the following pages.

Test Setup

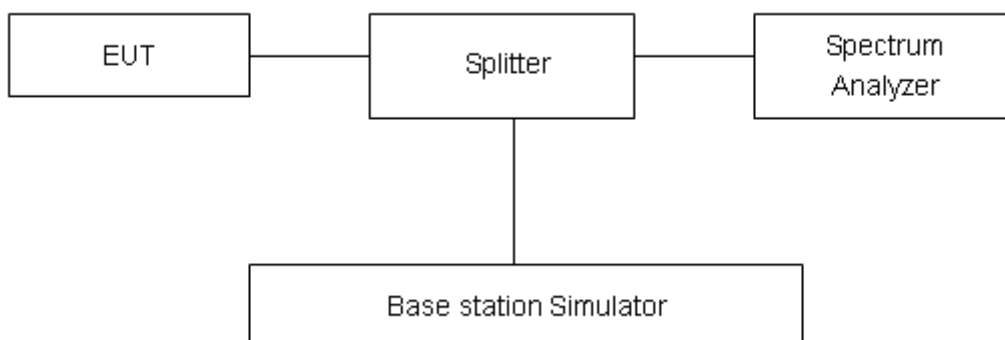

Limits

No specific occupied bandwidth requirements in part 2.1049.

Measurement Uncertainty

The assessed measurement uncertainty to ensure 95% confidence level for the normal distribution is with the coverage factor $k = 2$, $U = 624\text{Hz}$.

Test Result

Mode	Channel	Frequency (MHz)	99% Power Bandwidth (MHz)	-26dBc Bandwidth(MHz)
GPRS 850 (GMSK)	128	824.2	0.24403	0.3109
	190	836.6	0.24318	0.3118
	251	848.8	0.24488	0.3132
EGPRS 850 (8-PSK)	128	824.2	0.24412	0.3106
	190	836.6	0.24015	0.3034
	251	848.8	0.24663	0.3085
WCDMA Band V (RMC)	4132	826.4	4.1363	4.6850
	4183	836.6	4.1185	4.6680
	4233	846.6	4.1325	4.6700



LTE Band 5						
RB	Modulation	Bandwidth (MHz)	Channel	Frequency (MHz)	99% Power Bandwidth(MHz)	-26dBc Bandwidth(MHz)
100%	QPSK	1.4	20407	824.7	1.0954	1.292
			20525	836.5	1.0973	1.291
			20643	848.3	1.0998	1.283
		3	20415	825.5	2.7037	3.005
			20525	836.5	2.7064	2.958
			20635	847.5	2.7139	3.004
		5	20425	826.5	4.5183	5.012
			20525	836.5	4.5176	4.941
			20625	846.5	4.5160	4.930
		10	20450	829	8.9987	9.813
			20525	836.5	8.9642	9.773
			20600	844	8.9819	9.782
	16QAM	1.4	20407	824.7	1.0981	1.296
			20525	836.5	1.0909	1.271
			20643	848.3	1.0942	1.282
		3	20415	825.5	2.6916	2.938
			20525	836.5	2.7025	2.971
			20635	847.5	2.7021	2.991
		5	20425	826.5	4.5022	4.928
			20525	836.5	4.5001	4.984
			20625	846.5	4.5181	4.950
		10	20450	829	9.0153	9.723
			20525	836.5	8.9576	9.685
			20600	844	8.9494	9.651

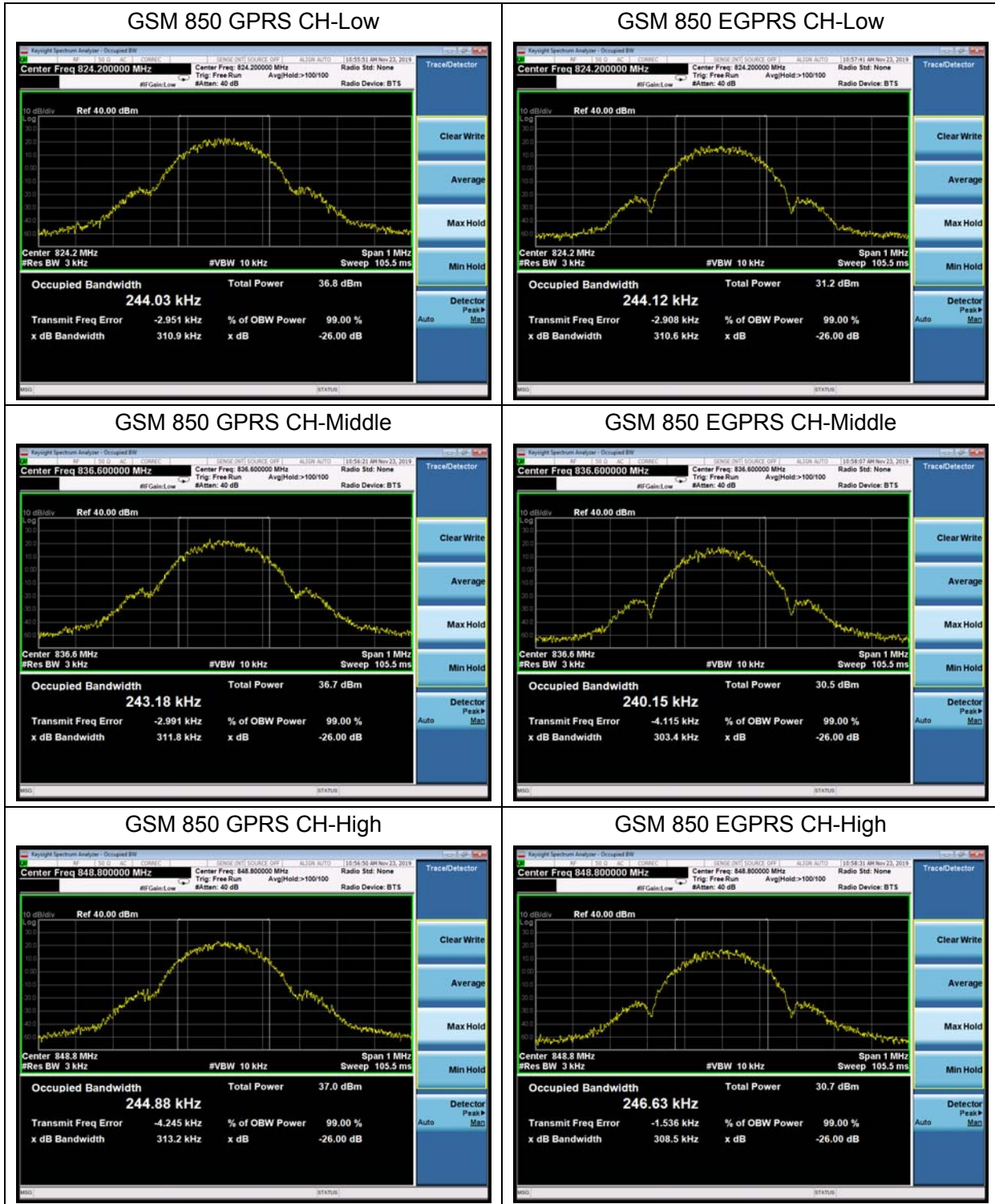

WCDMA Band V CH-Low



WCDMA Band V CH-Middle



WCDMA Band V CH-High



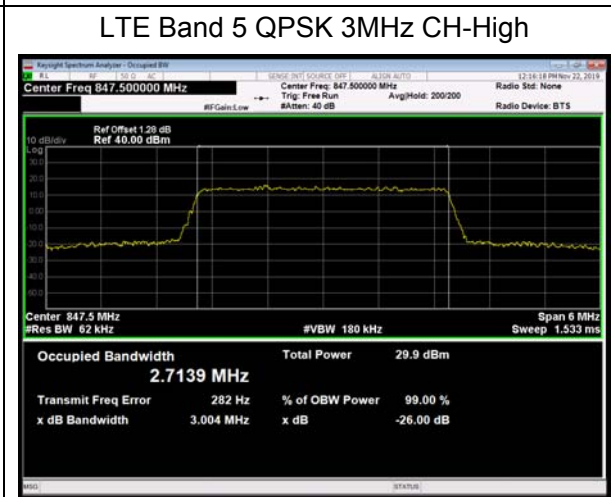
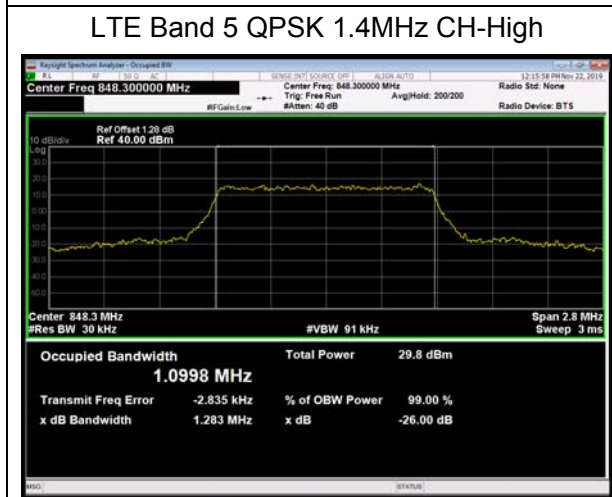
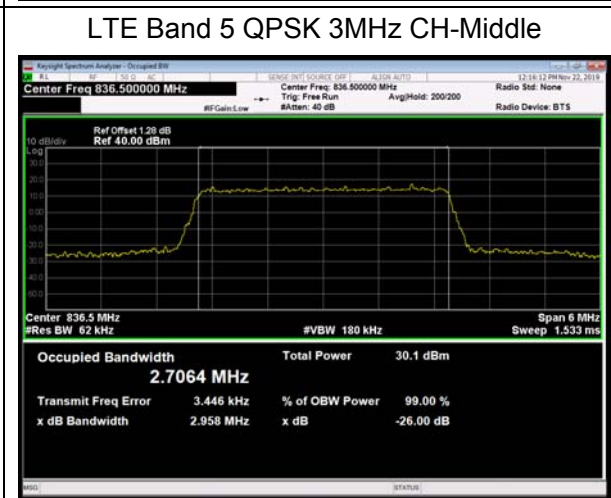
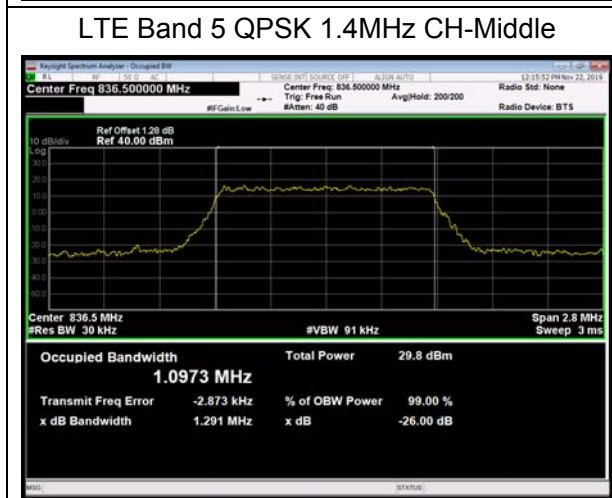
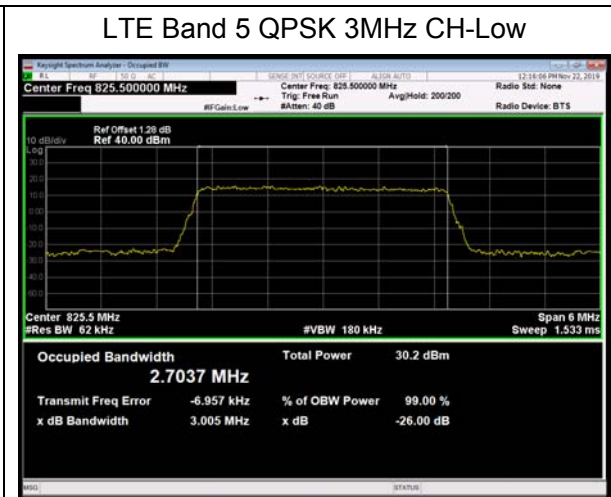
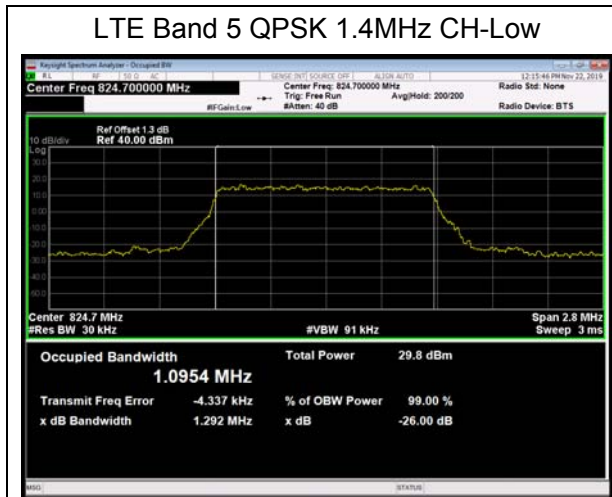

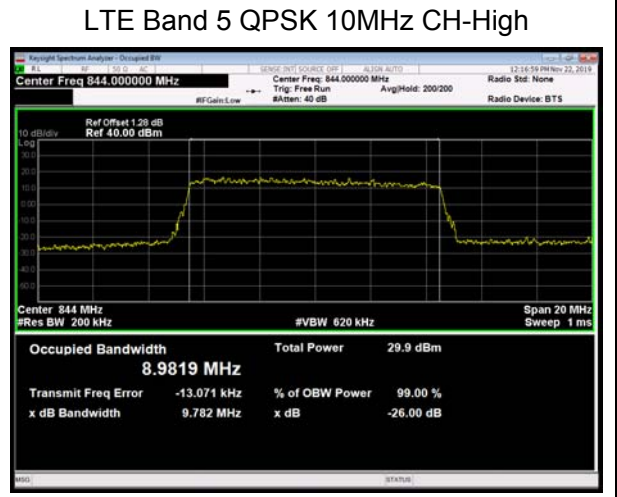
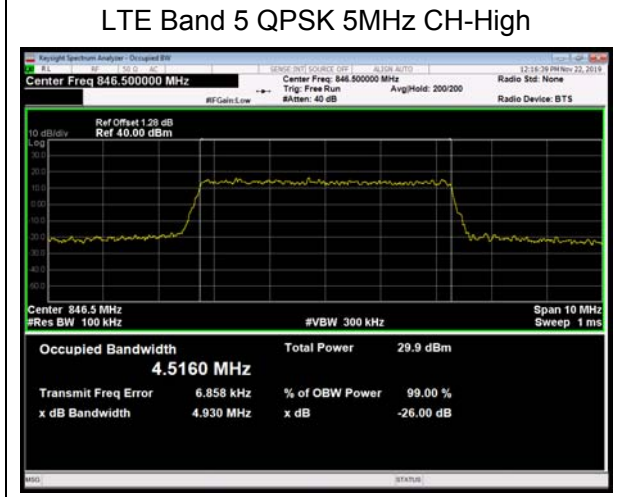
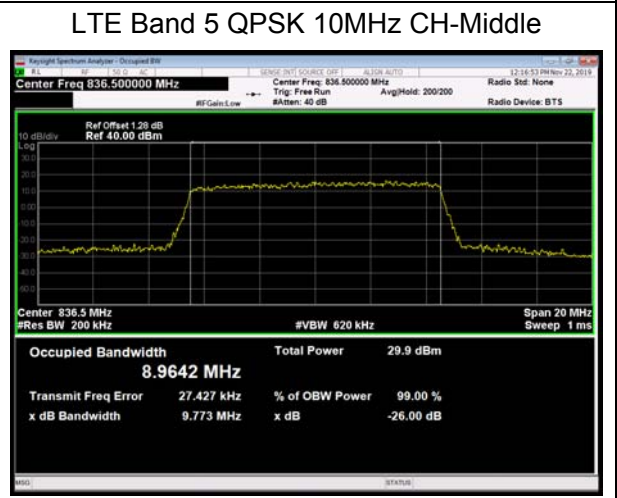
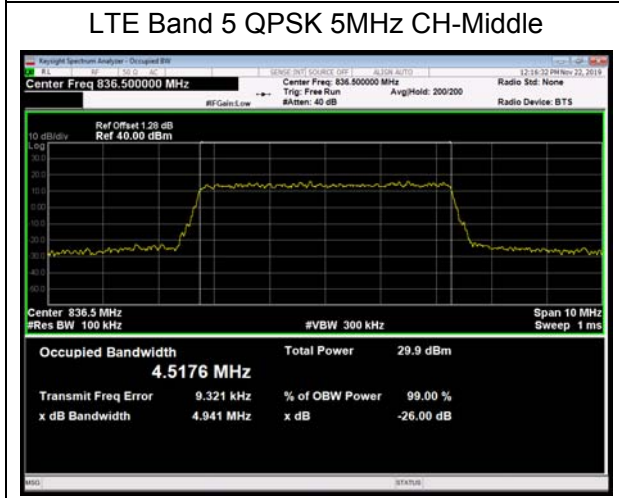
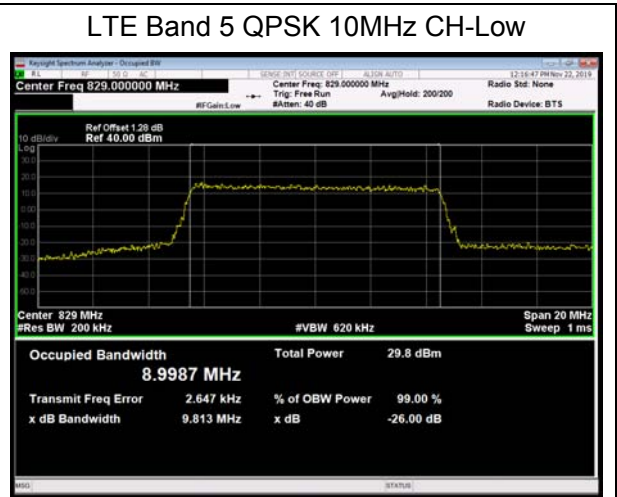
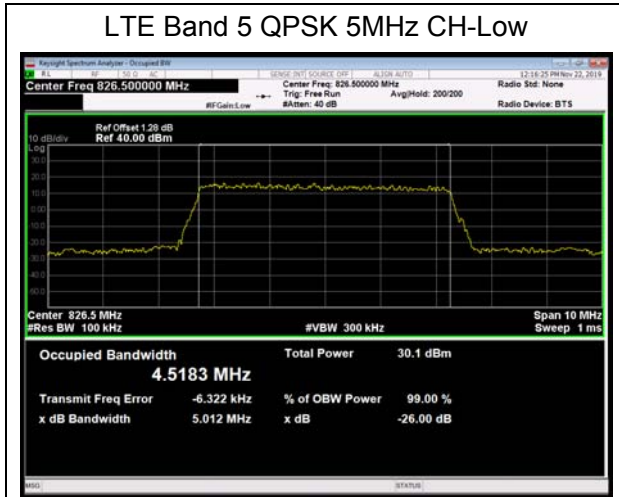

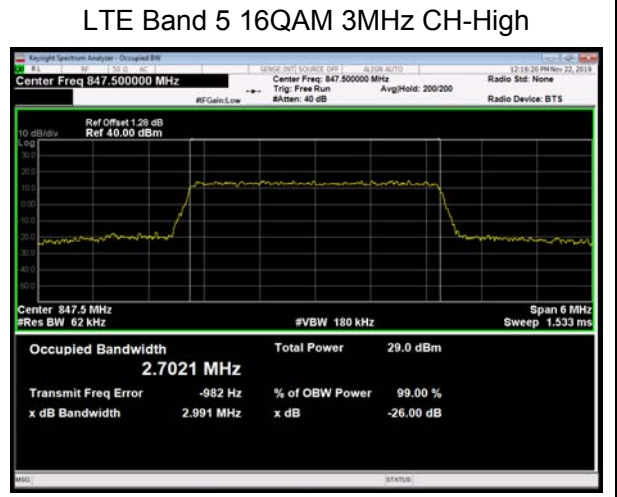
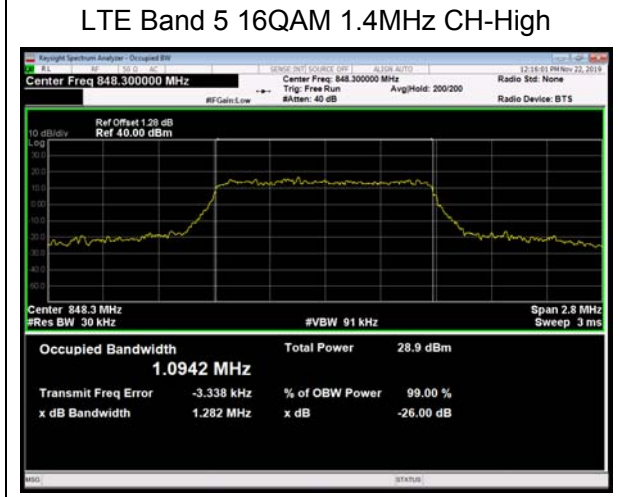
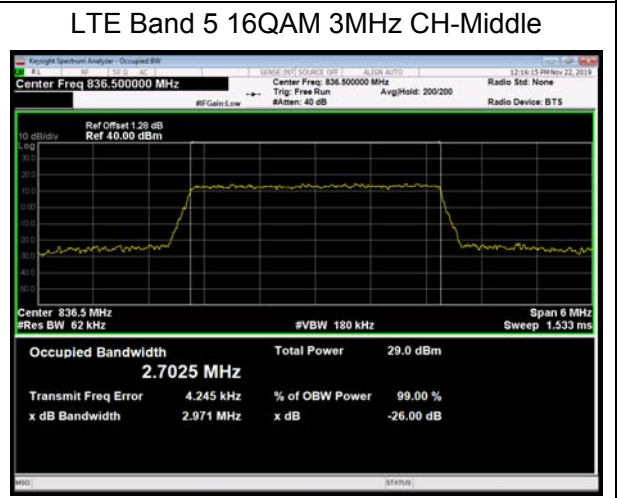
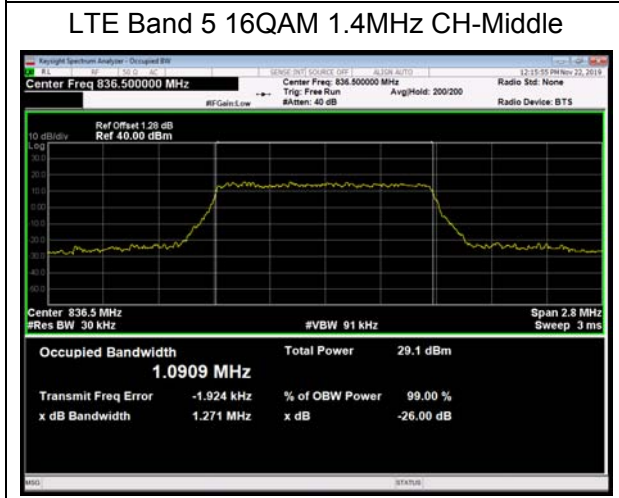
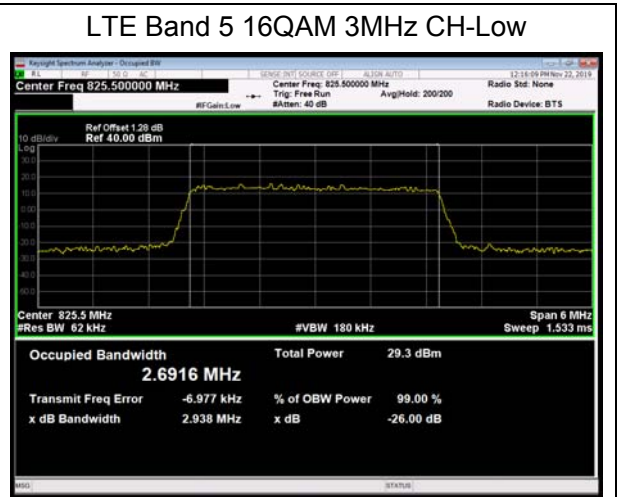
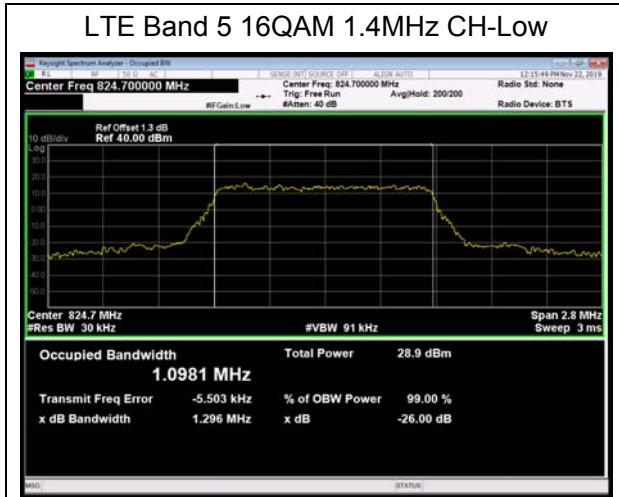

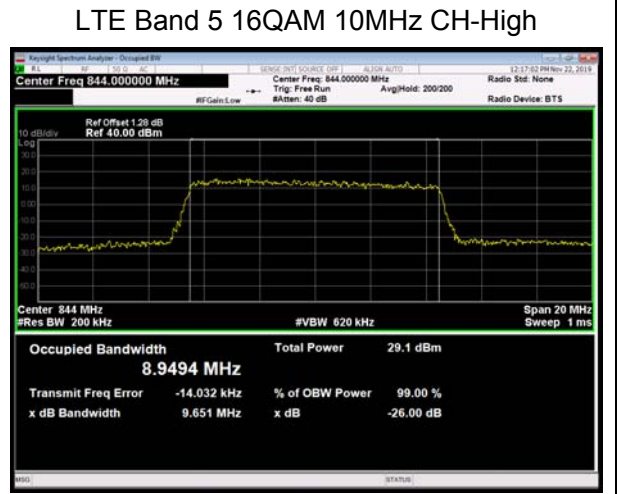
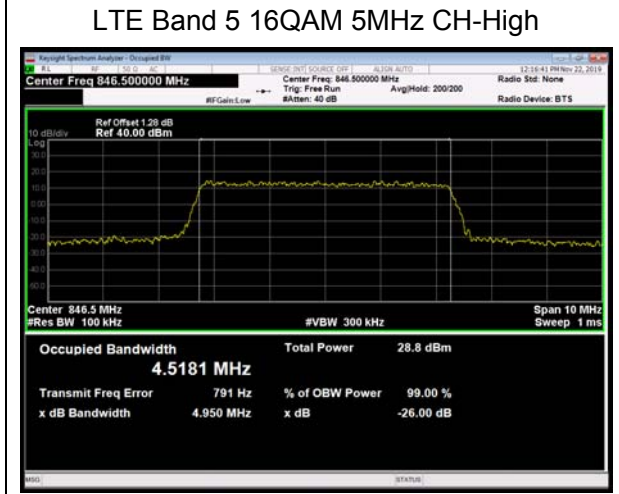
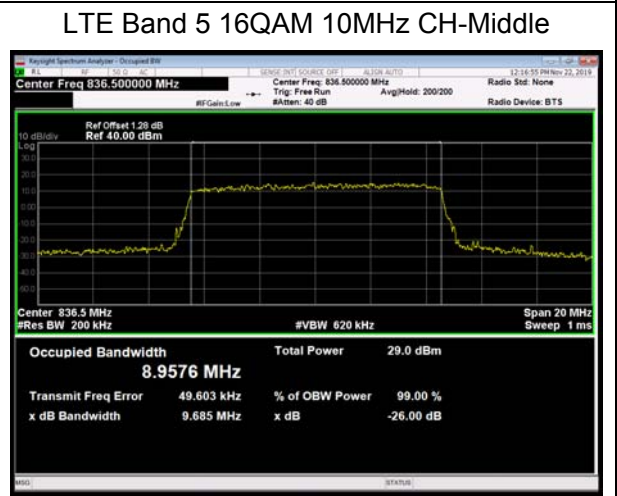
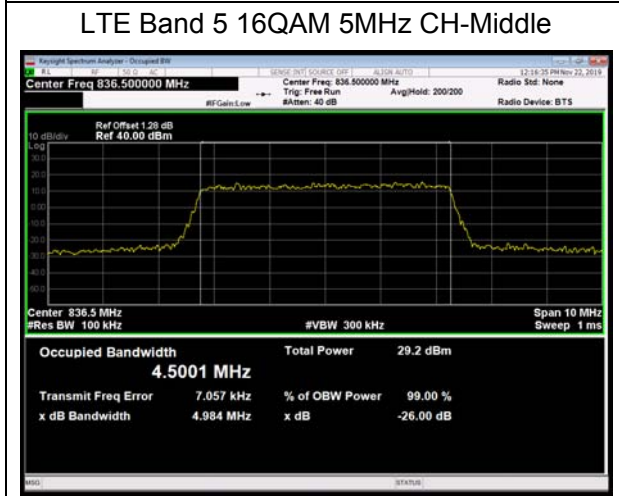
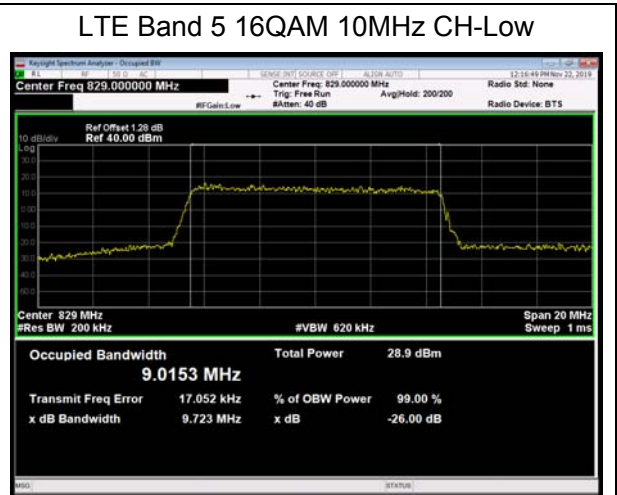
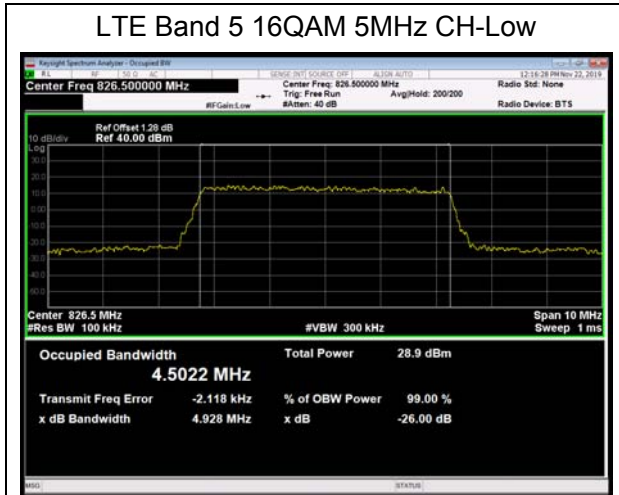

5.3. Band Edge Compliance

Ambient condition

Temperature	Relative humidity	Pressure
23°C ~25°C	45%~50%	101.5kPa

Method of Measurement

The EUT was connected to Spectrum Analyzer and Base Station Simulator via power Splitter. The band edge of the lowest and highest channels were measured. The average detector is used. RBW is set to 3kHz,VBW is set to 10kHz for GSM 850, RBW is set to 51kHz,VBW is set to 160kHz for WCDMA Band V, RBW is set to 15kHz, VBW is set to 43kHz for LTE Band 5 (1.4MHz), RBW is set to 30kHz,VBW is set to 91kHz for LTE Band 5 (3MHz), RBW is set to 51kHz,VBW is set to 150kHz for LTE Band 5 (5MHz), RBW is set to 100kHz,VBW is set to 300kHz for LTE Band 5 (10MHz), Spectrum analyzer plots are included on the following pages.

Test Setup

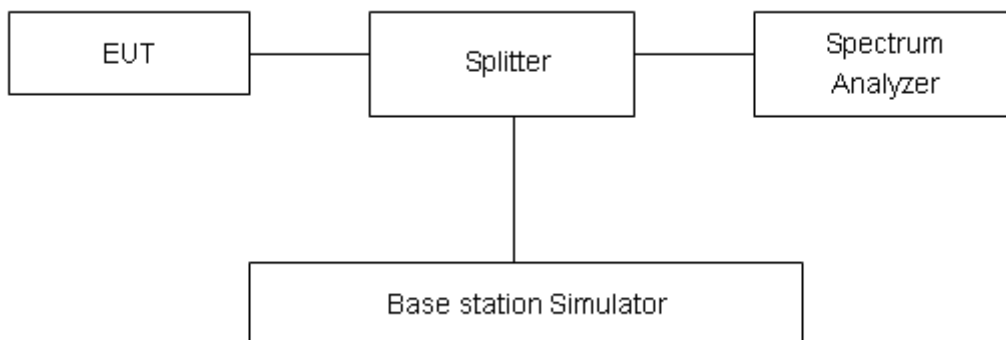

Limits

Rule Part 22.917(a) specifies that “The power of any emission outside of the authorized operating frequency ranges must be attenuated below the transmitting power (P) by a factor of at least 43 + 10 log(P) dB.”

Limit	-13 dBm
-------	---------

Measurement Uncertainty

The assessed measurement uncertainty to ensure 95% confidence level for the normal distribution is with the coverage factor $k = 1.96$, $U=0.684$ dB.



Test Result:

GSM 850 GPRS CH-Low



GSM 850 GPRS CH-High

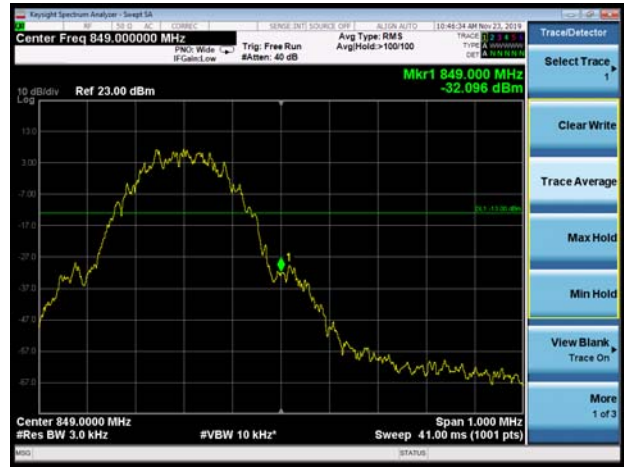

GSM 850 EGPRS CH-Low

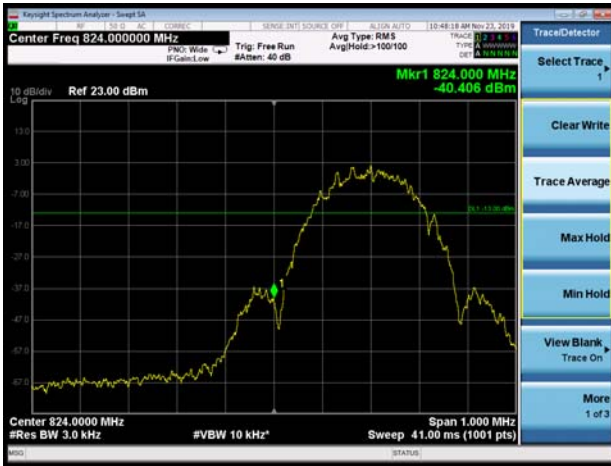

GSM 850 EGPRS CH-High



WCDMA Band V CH-Low



WCDMA Band V CH-High



LTE Band 5 QPSK 1.4MHz CH-Low 1RB

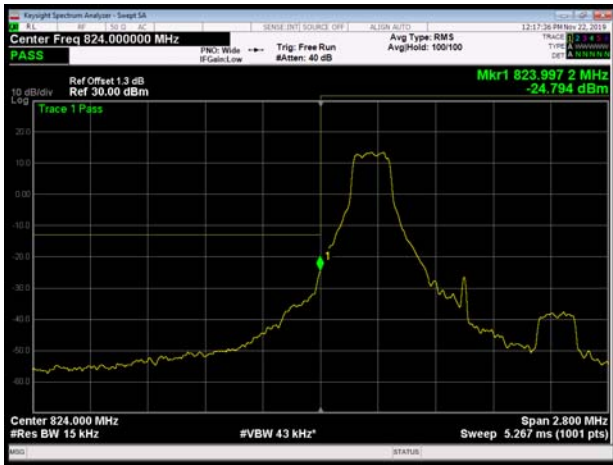

LTE Band 5 QPSK 1.4MHz CH-High 1RB



LTE Band 5 QPSK 1.4MHz CH-Low 100%RB

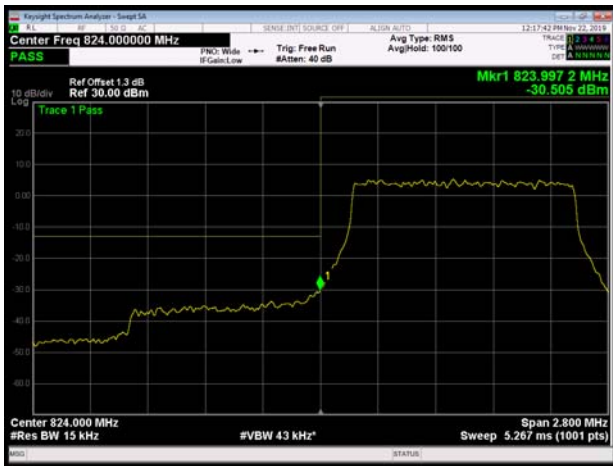

LTE Band 5 QPSK 1.4MHz CH-High 100%RB



LTE Band 5 QPSK 3MHz CH-Low 1RB

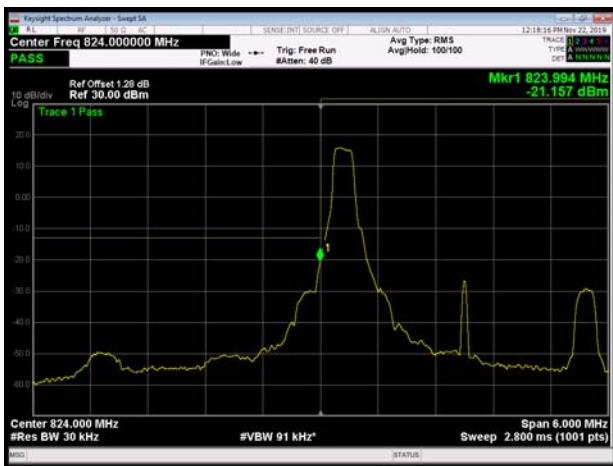

LTE Band 5 QPSK 3MHz CH-High 1RB

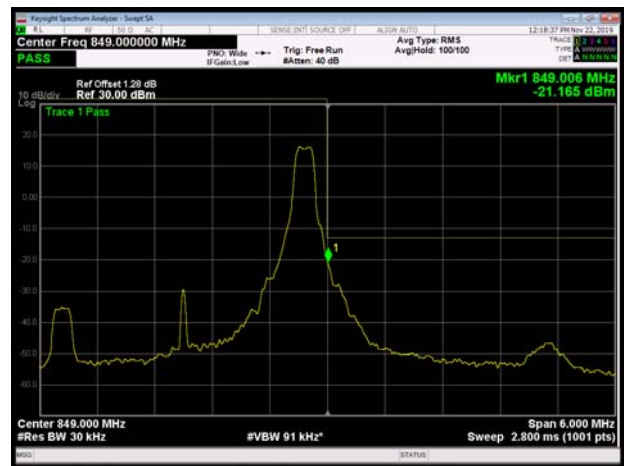

LTE Band 5 QPSK 3MHz CH-Low 100%RB

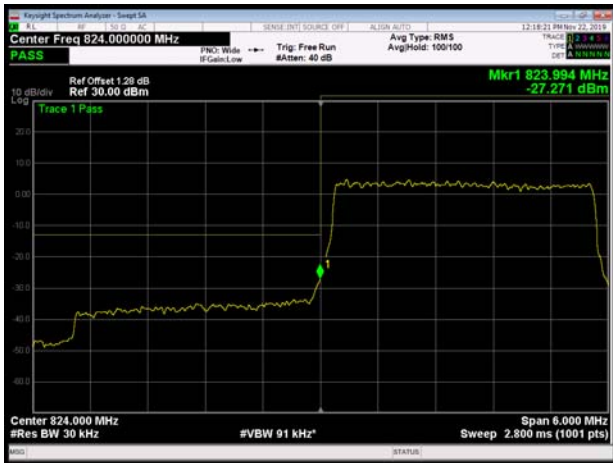

LTE Band 5 QPSK 3MHz CH-High 100%RB



LTE Band 5 QPSK 5MHz CH-Low 1RB

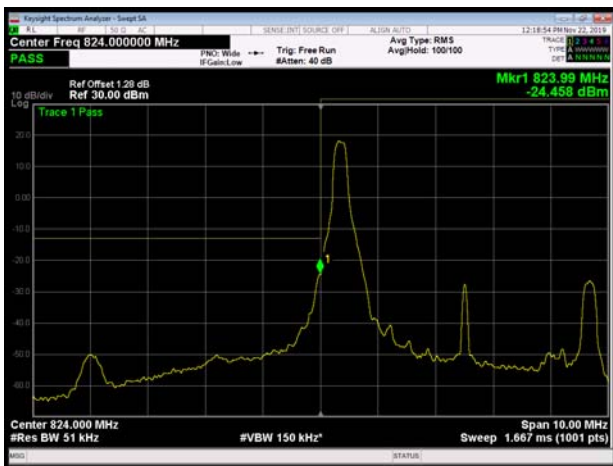

LTE Band 5 QPSK 5MHz CH-High 1RB

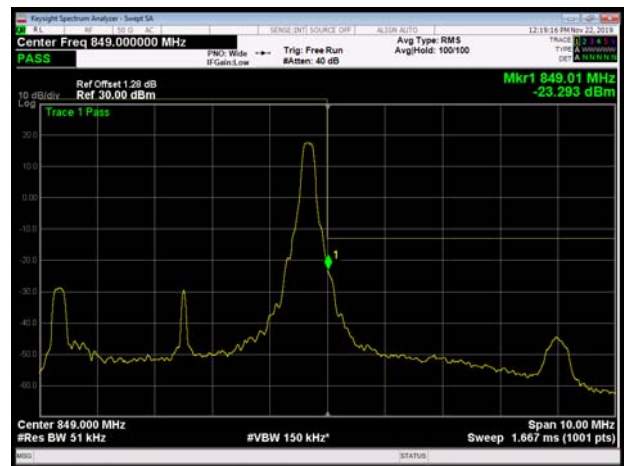

LTE Band 5 QPSK 5MHz CH-Low 100%RB

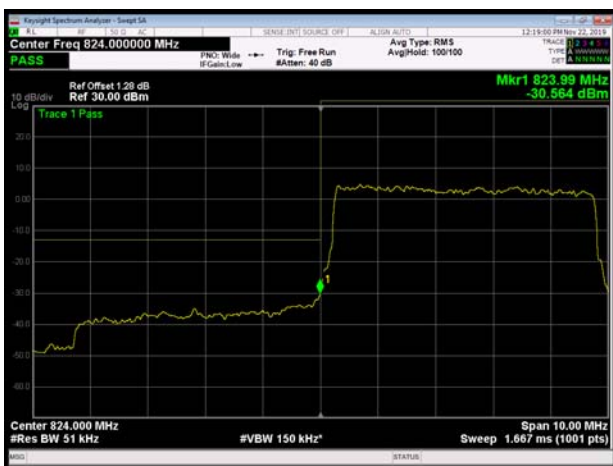

LTE Band 5 QPSK 5MHz CH-High 100%RB

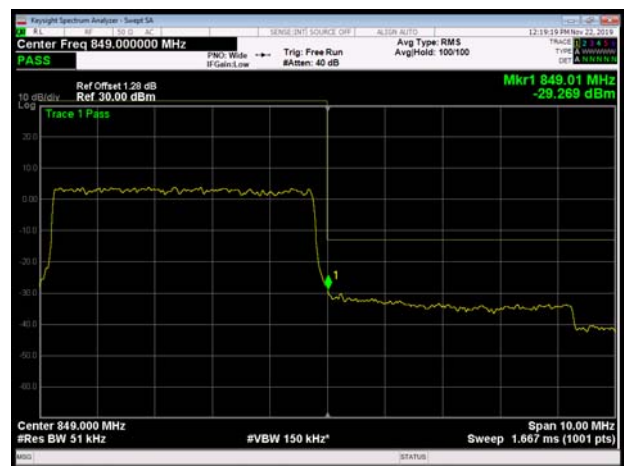



LTE Band 5 QPSK 10MHz CH-Low 1RB

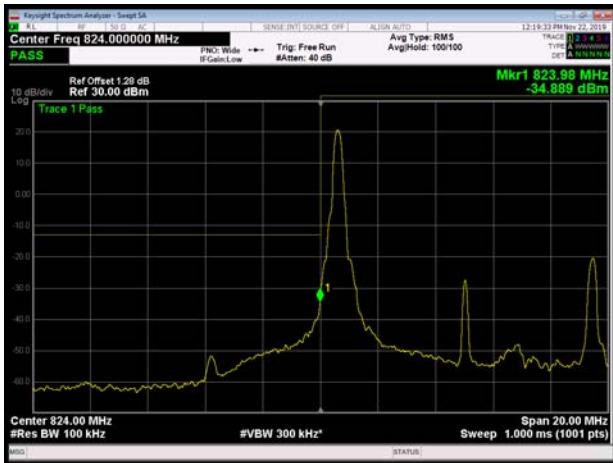

LTE Band 5 QPSK 10MHz CH-High 1RB

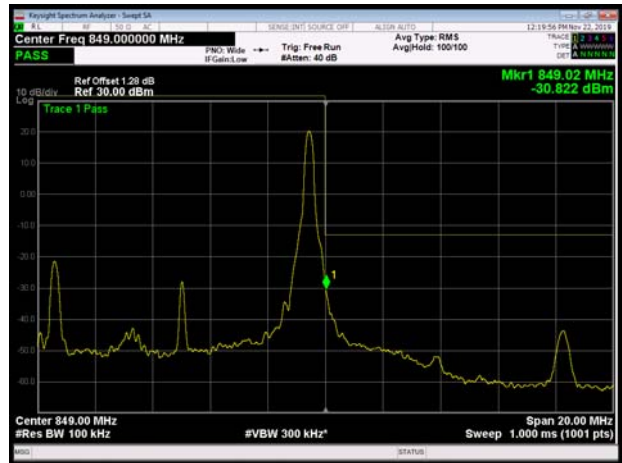

LTE Band 5 QPSK 10MHz CH-Low 100%RB

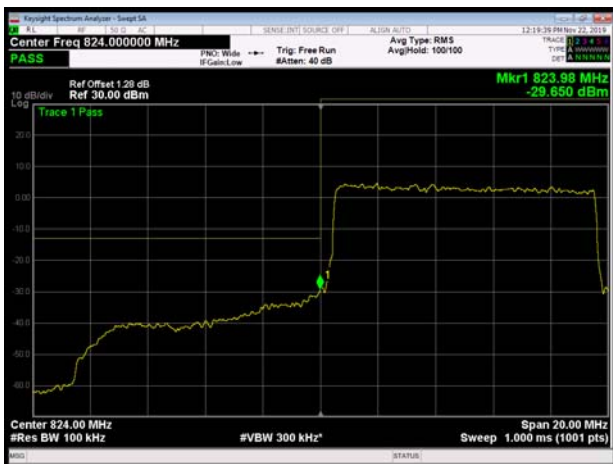

LTE Band 5 QPSK 10MHz CH-High 100%RB

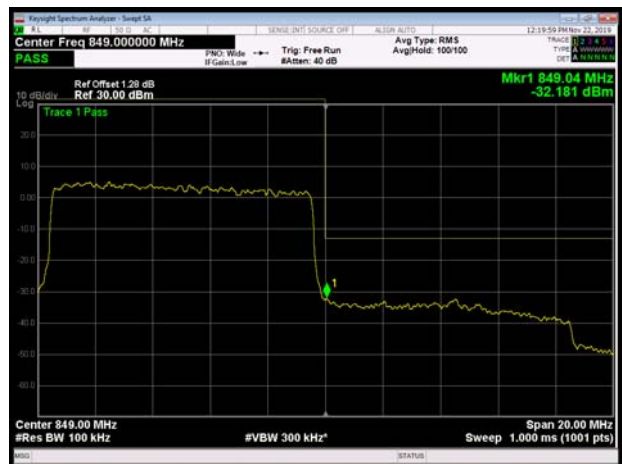

LTE Band 5 16QAM 1.4MHz CH-Low 1RB

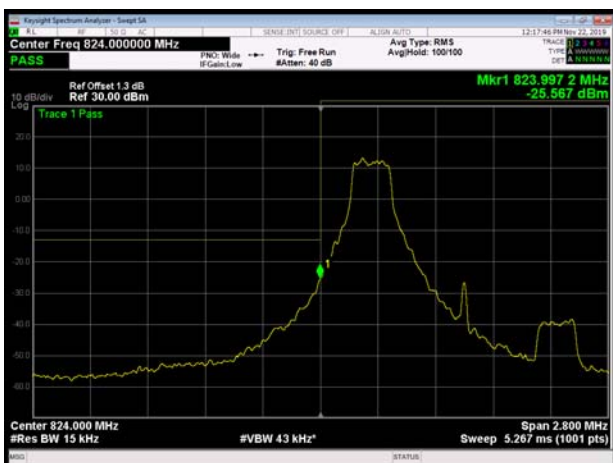

LTE Band 5 16QAM 1.4MHz CH-High 1RB

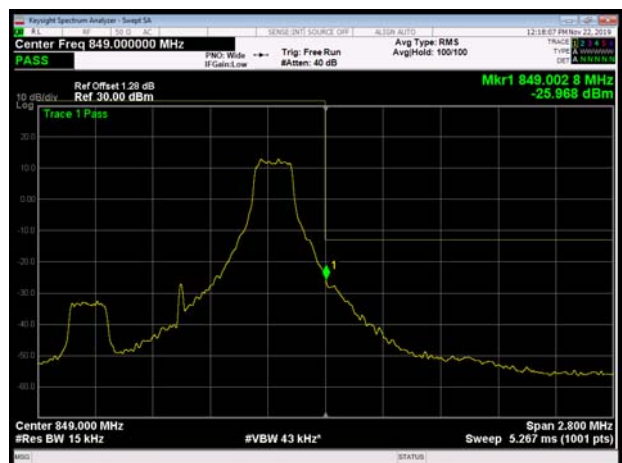



LTE Band 5 16QAM 1.4MHz CH-Low 100%RB

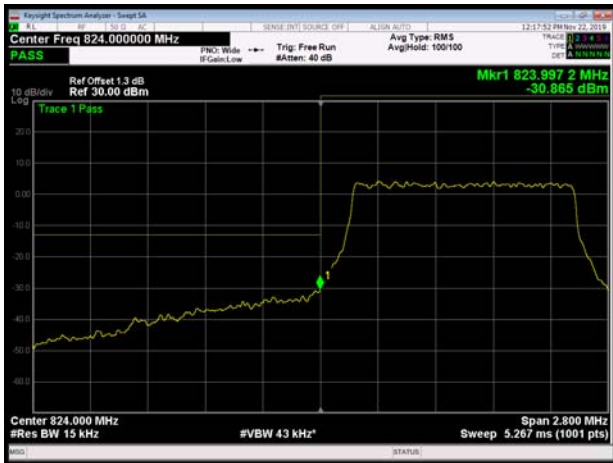

LTE Band 5 16QAM 1.4MHz CH-High 100%RB



LTE Band 5 16QAM 3MHz CH-Low 1RB

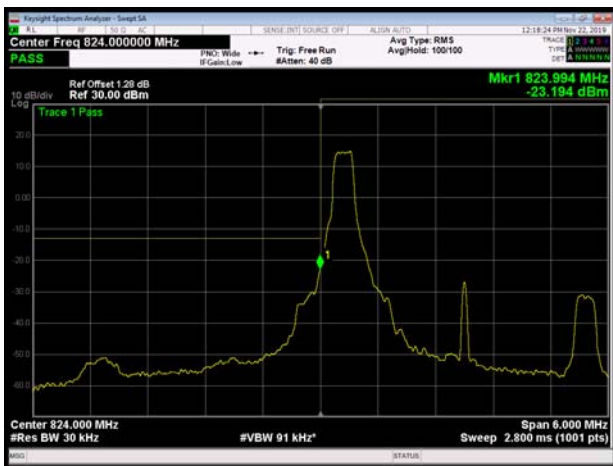

LTE Band 5 16QAM 3MHz CH-High 1RB

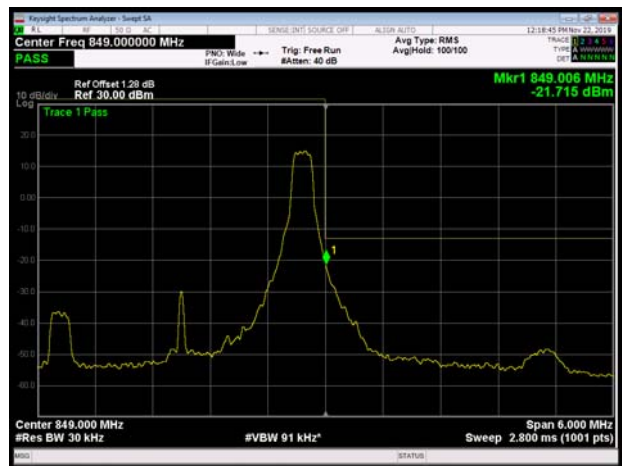

LTE Band 5 16QAM 3MHz CH-Low 100%RB

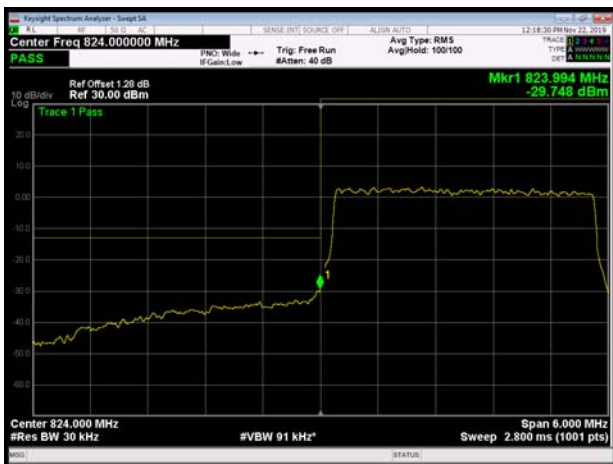

LTE Band 5 16QAM 3MHz CH-High 100%RB

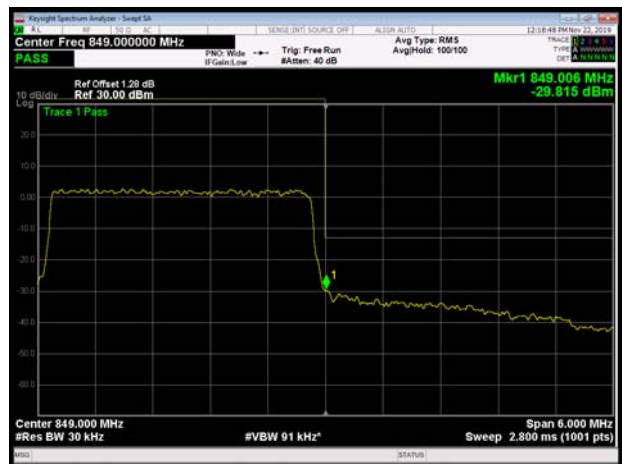



LTE Band 5 16QAM 5MHz CH-Low 1RB

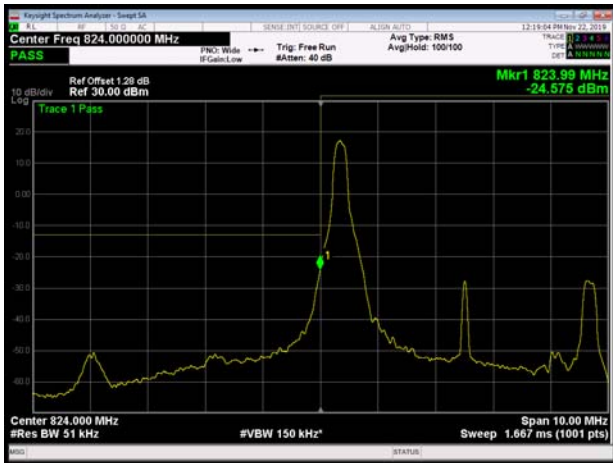

LTE Band 5 16QAM 5MHz CH-High 1RB

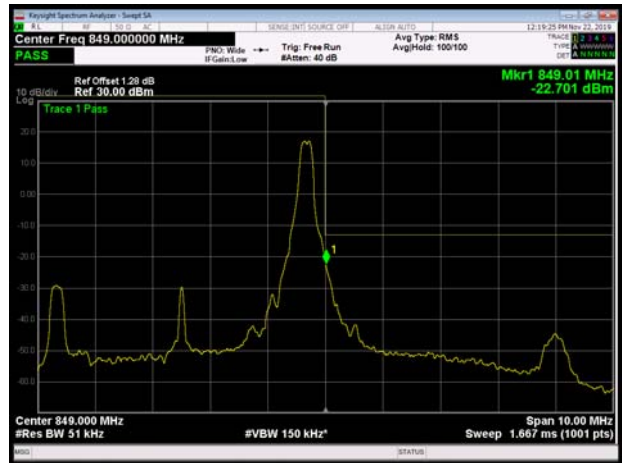

LTE Band 5 16QAM 5MHz CH-Low 100%RB

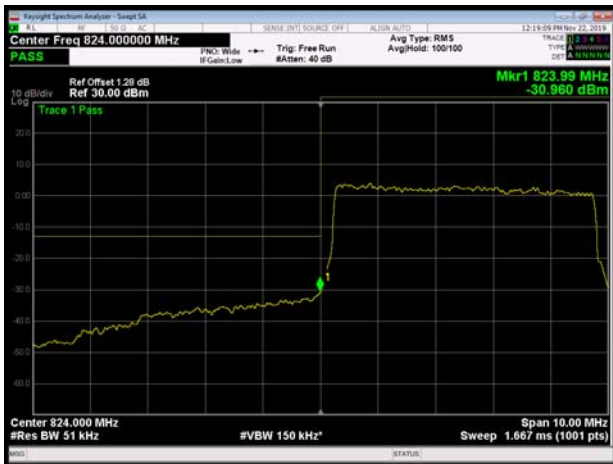

LTE Band 5 16QAM 5MHz CH-High 100%RB



LTE Band 5 16QAM 10MHz CH-Low 1RB

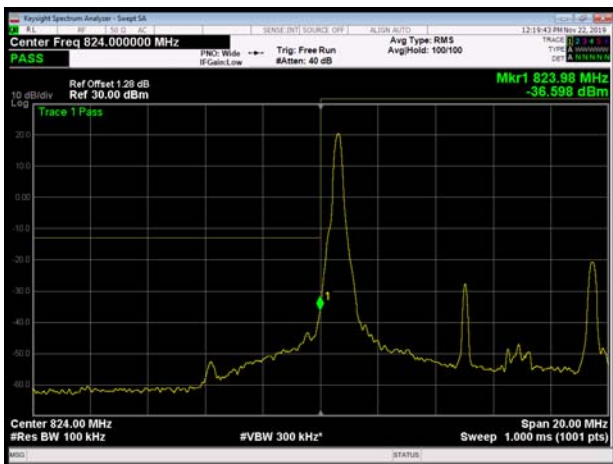

LTE Band 5 16QAM 10MHz CH-High 1RB

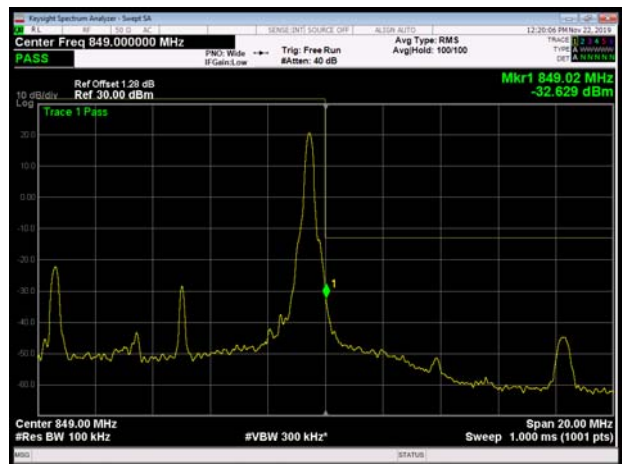



LTE Band 5 16QAM 10MHz CH-Low 100%RB



LTE Band 5 16QAM 10MHz CH-High 100%RB



5.4. Peak-to-Average Power Ratio (PAPR)

Ambient condition

Temperature	Relative humidity	Pressure
23°C ~25°C	45%~50%	101.5kPa

Methods of Measurement

Measure the total peak power and record as P_{Pk} . And measure the total average power and record as P_{Avg} . Both the peak and average power levels must be expressed in the same logarithmic units (e.g., dBm). Determine the PAPR from:

$$PAPR (dB) = P_{Pk} (dBm) - P_{Avg} (dBm).$$

Test Setup

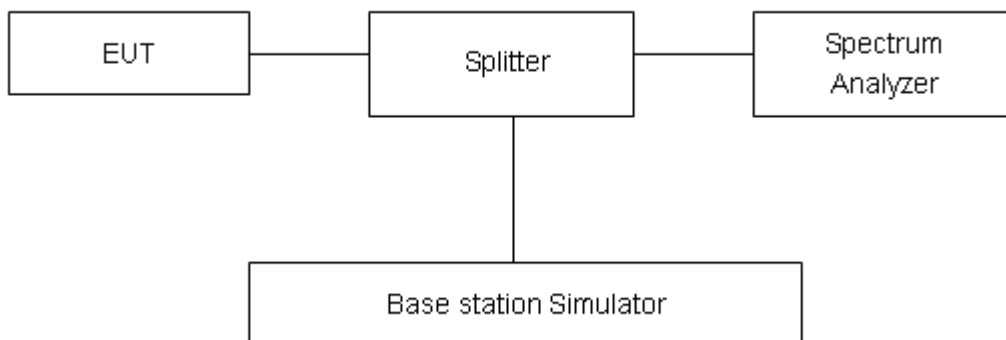

Limits

According to the Sec. 22.913(d), The peak-to-average ratio (PAR) of the transmission must not exceed 13 dB.

Measurement Uncertainty

The assessed measurement uncertainty to ensure 95% confidence level for the normal distribution is with the coverage factor $k = 2$, $U = 0.4$ dB.



Test Results

Mode	Channel	Frequency (MHz)	Peak (dBm)	Avg (dBm)	PAPR (dB)	Limit (dB)	Conclusion
GPRS 850 (GMSK)	128	824.2	33.58	31.94	1.64	≤13	PASS
	190	836.6	33.20	31.62	1.58	≤13	PASS
	251	848.8	33.50	31.89	1.61	≤13	PASS
EGPRS 850 (8-PSK)	128	824.2	28.99	26.14	2.85	≤13	PASS
	190	836.6	28.58	26.09	2.49	≤13	PASS
	251	848.8	28.55	26.02	2.53	≤13	PASS
WCDMA Band V (RMC)	4132	826.4	24.99	21.95	3.04	≤13	PASS
	4183	836.6	24.77	21.66	3.11	≤13	PASS
	4233	846.6	25.06	21.71	3.35	≤13	PASS

LTE Band 5								
Modulation	Bandwidth (MHz)	Channel	Frequency (MHz)	Peak (dBm)	Avg (dBm)	PAPR (dB)	Limit (dB)	Conclusion
QPSK	1.4	20407	824.7	27.25	22.24	5.01	≤13	PASS
		20525	836.5	27.94	22.21	5.73	≤13	PASS
		20643	848.3	28.14	22.09	6.05	≤13	PASS
	3	20415	825.5	27.37	22.27	5.10	≤13	PASS
		20525	836.5	28.07	22.24	5.83	≤13	PASS
		20635	847.5	28.18	22.09	6.09	≤13	PASS
	5	20425	826.5	27.42	22.20	5.22	≤13	PASS
		20525	836.5	27.91	22.15	5.76	≤13	PASS
		20625	846.5	28.09	22.11	5.98	≤13	PASS
	10	20450	829	27.73	22.10	5.63	≤13	PASS
		20525	836.5	27.85	22.19	5.66	≤13	PASS
		20600	844	27.79	22.13	5.66	≤13	PASS
16QAM	1.4	20407	824.7	27.04	21.22	5.82	≤13	PASS
		20525	836.5	28.04	21.43	6.61	≤13	PASS
		20643	848.3	28.18	21.28	6.90	≤13	PASS
	3	20415	825.5	27.21	21.36	5.85	≤13	PASS
		20525	836.5	28.07	21.41	6.66	≤13	PASS
		20635	847.5	28.10	21.19	6.91	≤13	PASS
	5	20425	826.5	27.26	21.31	5.95	≤13	PASS
		20525	836.5	27.80	21.28	6.52	≤13	PASS
		20625	846.5	27.84	21.14	6.70	≤13	PASS



	10	20450	829	27.39	21.09	6.30	≤13	PASS
		20525	836.5	27.64	21.20	6.44	≤13	PASS
		20600	844	27.63	21.22	6.41	≤13	PASS

5.5. Frequency Stability

Ambient condition

Temperature	Relative humidity	Pressure
23°C ~25°C	45%~50%	101.5kPa

Method of Measurement

Frequency Stability (Temperature Variation)

The temperature inside the climate chamber is varied from -30°C to +60°C in 10°C step size,

(1) With all power removed, the temperature was decreased to 0°C and permitted to stabilize for three hours.

(2) Measure the carrier frequency with the test equipment in a “call mode”. These measurements should be made within 1 minute of powering up the mobile station, to prevent significant self warming.

(3) Repeat the above measurements at 10°C increments from -30°C to +60°C. Allow at least 1.5 hours at each temperature, un-powered, before making measurements.

Frequency Stability (Voltage Variation)

The frequency stability shall be measured with variation of primary supply voltage as follows:

(1) Vary primary supply voltage from 85 to 115 percent of the nominal value for other than hand carried battery equipment.

(2) For hand carried, battery powered equipment, reduce primary supply voltage to the battery-operating end point which shall be specified by the manufacturer.

This transceiver is specified to operate with an input voltage of between 22.8 V and 25.2 V, with a nominal voltage of 24V.

Test setup

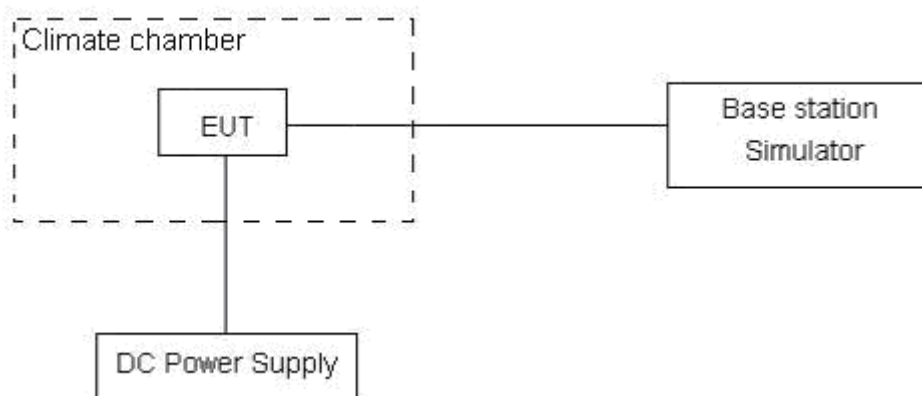

**Limits**

According to the Sec. 22.355, the frequency stability of the carrier shall be accurate to within 2.5 ppm of the received frequency for mobile stations.

Limits	≤ 2.5 ppm
--------	----------------

Measurement Uncertainty

The assessed measurement uncertainty to ensure 99.75% confidence level for the normal distribution is with the coverage factor $k = 3$, $U = 0.01$ ppm.

Test Result

GSM850						
Condition		Freq.Error (Hz)	Freq.Error (Hz)	Frequency Stability (ppm)	Frequency Stability (ppm)	Verdict
Temperature	Voltage	GMSK	8PSK	GMSK	8PSK	
Normal (25°C)	Normal	5.03	16.41	0.00268	0.00873	PASS
Extreme (60°C)		6.42	6.96	0.00342	0.00370	PASS
Extreme (50°C)		2.82	3.49	0.00150	0.00186	PASS
Extreme (40°C)		13.10	6.51	0.00697	0.00346	PASS
Extreme (30°C)		12.04	5.45	0.00640	0.00290	PASS
Extreme (20°C)		4.74	1.52	0.00252	0.00081	PASS
Extreme (10°C)		1.08	15.77	0.00058	0.00839	PASS
Extreme (0°C)		12.03	11.17	0.00640	0.00594	PASS
Extreme (-10°C)		4.06	12.55	0.00216	0.00667	PASS
Extreme (-20°C)		4.55	10.33	0.00242	0.00550	PASS
Extreme (-30°C)		15.70	9.14	0.00835	0.00486	PASS
25°C		LV	4.87	16.65	0.00259	0.00886
	HV	11.73	11.97	0.00624	0.00637	PASS

WCDMA Band 5						
Condition		Freq.Error (Hz)	Freq.Error (Hz)	Frequency Stability (ppm)	Frequency Stability (ppm)	Verdict
Temperature	Voltage	QPSK	BPSK	QPSK	BPSK	
Normal (25°C)	Normal	5.72	3.81	0.00304	0.00202	PASS
Extreme (55°C)		10.45	5.76	0.00556	0.00306	PASS
Extreme (50°C)		3.85	11.49	0.00205	0.00611	PASS
Extreme (40°C)		11.45	1.93	0.00609	0.00103	PASS
Extreme (30°C)		10.62	13.26	0.00565	0.00705	PASS
Extreme (20°C)		4.59	4.83	0.00244	0.00257	PASS
Extreme (10°C)		12.54	10.48	0.00667	0.00557	PASS
Extreme (0°C)		13.25	10.92	0.00705	0.00581	PASS
Extreme (-10°C)		14.12	13.24	0.00751	0.00704	PASS
Extreme (-20°C)		16.99	17.99	0.00904	0.00957	PASS
Extreme (-30°C)		2.61	14.53	0.00139	0.00773	PASS
25°C		LV	2.11	12.81	0.00112	0.00681
	HV	14.38	17.54	0.00765	0.00933	PASS



LTE Band 5						
Condition		Freq.Error (Hz)	Freq.Error (Hz)	Frequency Stability (ppm)	Frequency Stability (ppm)	Verdict
BANDWIDTH	1.4MHz					
Temperature	Voltage	16QAM	QPSK	16QAM	QPSK	
Normal (25°C)	Normal	13.72	8.89	0.00730	0.00473	PASS
Extreme (60°C)		11.04	2.55	0.00587	0.00135	PASS
Extreme (50°C)		8.15	9.10	0.00434	0.00484	PASS
Extreme (40°C)		8.80	5.27	0.00468	0.00280	PASS
Extreme (30°C)		5.15	3.47	0.00274	0.00185	PASS
Extreme (20°C)		6.66	15.78	0.00354	0.00839	PASS
Extreme (10°C)		15.28	6.60	0.00813	0.00351	PASS
Extreme (0°C)		13.92	3.32	0.00740	0.00177	PASS
Extreme (-10°C)		6.48	15.43	0.00345	0.00821	PASS
Extreme (-20°C)		10.72	11.39	0.00570	0.00606	PASS
Extreme (-30°C)		2.49	2.96	0.00133	0.00158	PASS
25°C	LV	6.91	9.54	0.00367	0.00508	PASS
	HV	16.55	17.79	0.00880	0.00946	PASS
Condition		Freq.Error (Hz)	Freq.Error (Hz)	Frequency Stability (ppm)	Frequency Stability (ppm)	Verdict
BANDWIDTH	3MHz					
Temperature	Voltage	16QAM	QPSK	16QAM	QPSK	
Normal (25°C)	Normal	15.96	8.59	0.00849	0.00457	PASS
Extreme (60°C)		4.23	8.79	0.00225	0.00467	PASS
Extreme (50°C)		17.54	5.67	0.00933	0.00302	PASS
Extreme (40°C)		9.96	6.60	0.00530	0.00351	PASS
Extreme (30°C)		8.10	1.18	0.00431	0.00063	PASS
Extreme (20°C)		13.03	14.95	0.00693	0.00795	PASS
Extreme (10°C)		7.57	10.92	0.00403	0.00581	PASS
Extreme (0°C)		8.02	12.80	0.00427	0.00681	PASS
Extreme (-10°C)		1.16	4.64	0.00062	0.00247	PASS
Extreme (-20°C)		12.05	13.67	0.00641	0.00727	PASS
Extreme (-30°C)		16.18	6.95	0.00861	0.00370	PASS
25°C	LV	13.18	3.81	0.00701	0.00203	PASS
	HV	16.74	9.93	0.00890	0.00528	PASS
Condition		Freq.Error (Hz)	Freq.Error (Hz)	Frequency Stability (ppm)	Frequency Stability (ppm)	Verdict
BANDWIDTH	5MHz					
Temperature	Voltage	16QAM	QPSK	16QAM	QPSK	
Normal (25°C)	Normal	2.92	6.35	0.00156	0.00338	PASS
Extreme (60°C)		13.64	6.65	0.00725	0.00354	PASS



Extreme (50°C)		11.48	4.36	0.00611	0.00232	PASS
Extreme (40°C)		9.39	1.27	0.00499	0.00068	PASS
Extreme (30°C)		6.00	15.88	0.00319	0.00845	PASS
Extreme (20°C)		11.96	3.76	0.00636	0.00200	PASS
Extreme (10°C)		17.20	8.06	0.00915	0.00429	PASS
Extreme (0°C)		4.23	4.86	0.00225	0.00258	PASS
Extreme (-10°C)		2.03	13.07	0.00108	0.00695	PASS
Extreme (-20°C)		10.90	11.14	0.00580	0.00593	PASS
Extreme (-30°C)		10.66	6.50	0.00567	0.00346	PASS
25°C	LV	13.27	2.78	0.00706	0.00148	PASS
	HV	11.51	13.03	0.00612	0.00693	PASS
Condition		Freq.Error (Hz)	Freq.Error (Hz)	Frequency Stability (ppm)	Frequency Stability (ppm)	Verdict
BANDWIDTH	10MHz					
Temperature	Voltage	16QAM	QPSK	16QAM	QPSK	
Normal (25°C)	Normal	14.74	10.82	0.00784	0.00575	PASS
Extreme (60°C)		16.32	5.03	0.00868	0.00268	PASS
Extreme (50°C)		8.29	5.24	0.00441	0.00279	PASS
Extreme (40°C)		5.05	13.07	0.00269	0.00695	PASS
Extreme (30°C)		10.48	14.25	0.00557	0.00758	PASS
Extreme (20°C)		1.79	6.90	0.00095	0.00367	PASS
Extreme (10°C)		9.20	1.14	0.00490	0.00061	PASS
Extreme (0°C)		1.91	11.17	0.00102	0.00594	PASS
Extreme (-10°C)		12.27	15.65	0.00652	0.00833	PASS
Extreme (-20°C)		7.18	11.12	0.00382	0.00591	PASS
Extreme (-30°C)		16.89	13.49	0.00898	0.00718	PASS
25°C		LV	3.51	2.44	0.00187	0.00130
	HV	5.85	6.32	0.00311	0.00336	PASS

5.6. Spurious Emissions at Antenna Terminals

Ambient condition

Temperature	Relative humidity	Pressure
23°C ~25°C	45%~50%	101.5kPa

Method of Measurement

The EUT was connected to Spectrum Analyzer and Base Station Simulator via power Splitter. The measurement is carried out using a spectrum analyzer. The spectrum analyzer scans from 9kHz to the 10th harmonic of the carrier.

The peak detector is used. RBW are set to 100 kHz and VBW are set to 300 kHz for below 1G, RBW are set to 1MHz and VBW are set to 3MHz for above 1G, Sweep is set to ATUO.

The modulation mode and RB allocation refer to section 5.1, using the maximum output power configuration.

Test setup

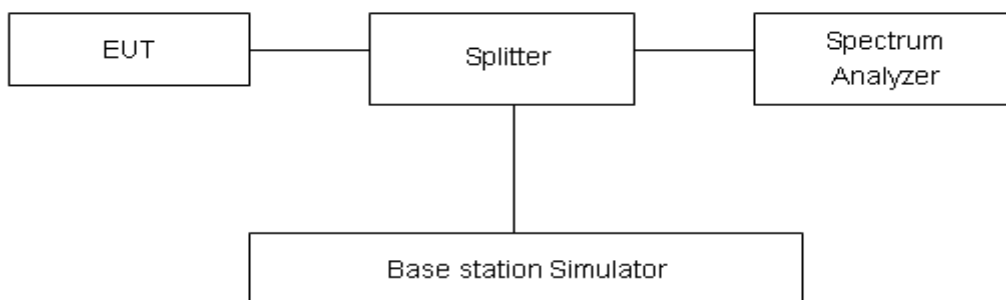

Limits

Rule Part 22.917(a) specifies that “The power of any emission outside of the authorized operating frequency ranges must be attenuated below the transmitting power (P) by a factor of at least 43 + 10 log (P) dB.”

Limit	-13 dBm
-------	---------

Measurement Uncertainty

The assessed measurement uncertainty to ensure 99.75% confidence level for the normal distribution is with the coverage factor $k = 1.96$.

Frequency	Uncertainty
9kHz-1GHz	0.684 dB
1GHz-18GHz	1.407 dB



Test Result

Sweep the whole frequency band through the range from 9kHz to the 10th harmonic of the carrier, the emissions more than 20 dB below the limit are not reported.

The signal beyond the limit is carrier.

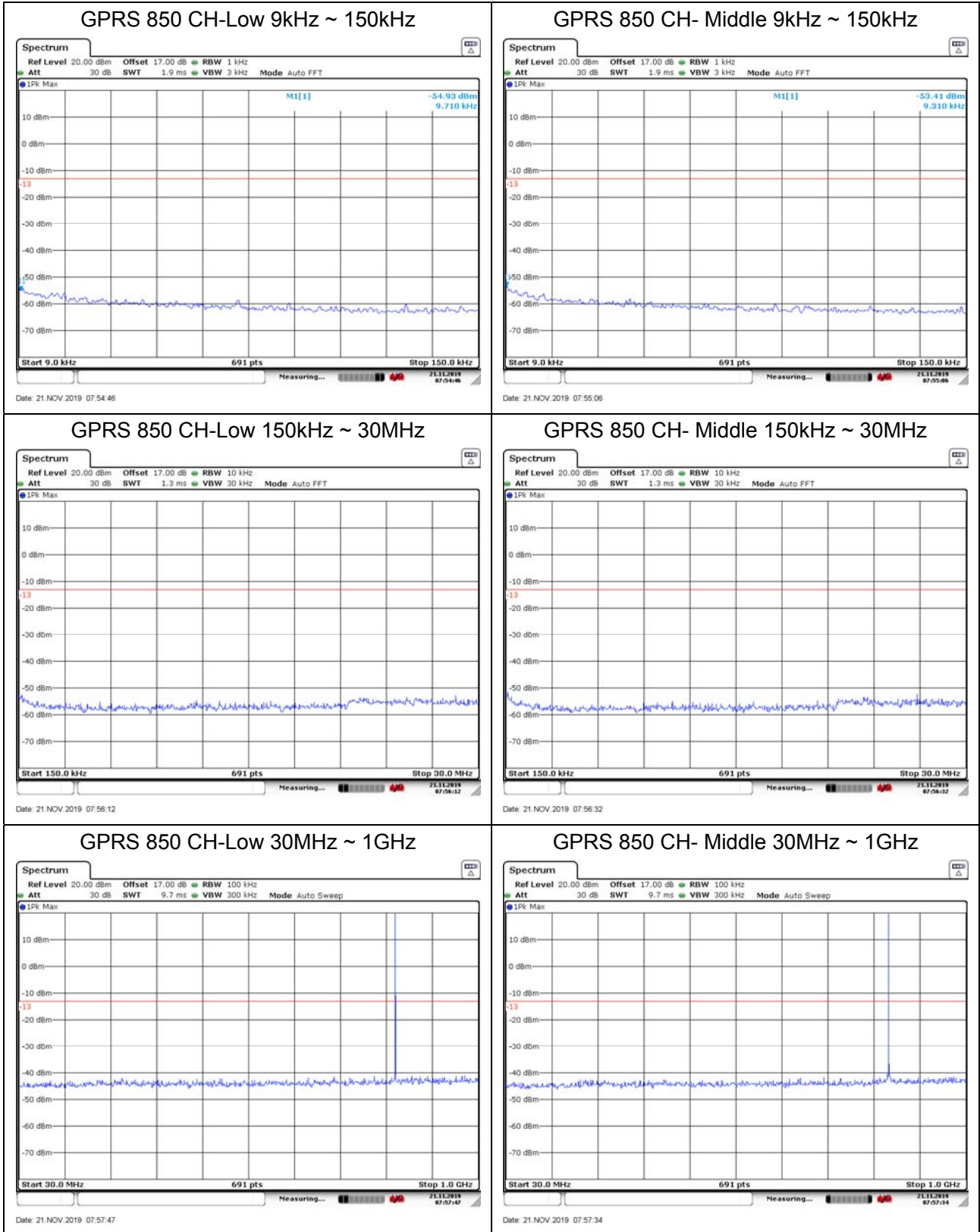



GPRS 850 CH-Low 1GHz ~ 9GHz

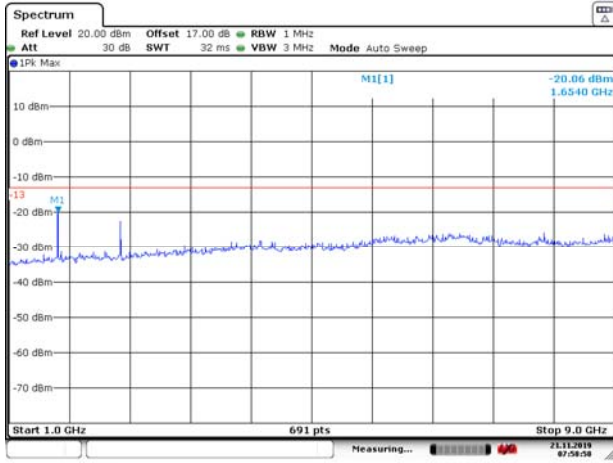

Date: 21.NOV.2019 07:58:58

GPRS 850 CH- Middle 1GHz ~ 9GHz

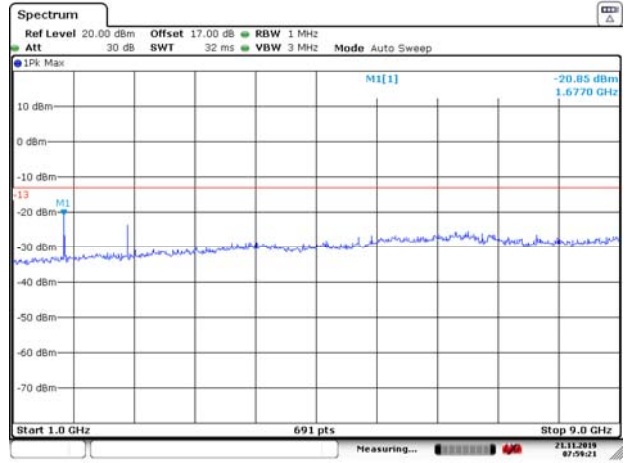

Date: 21.NOV.2019 07:59:22

GPRS 850 CH-High 9kHz ~ 150kHz

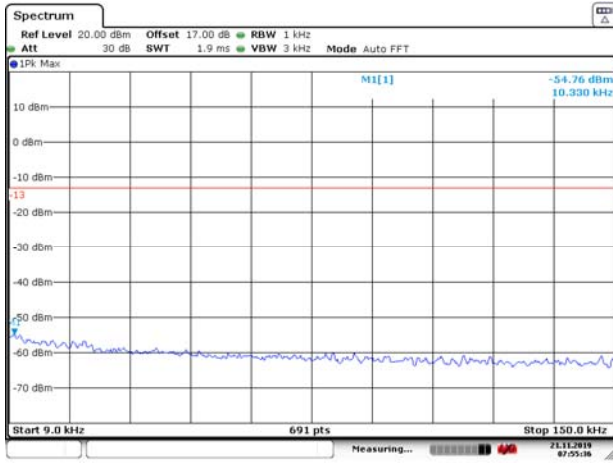

Date: 21.NOV.2019 07:55:37

EGPRS 850 CH-Low 9kHz ~ 150kHz

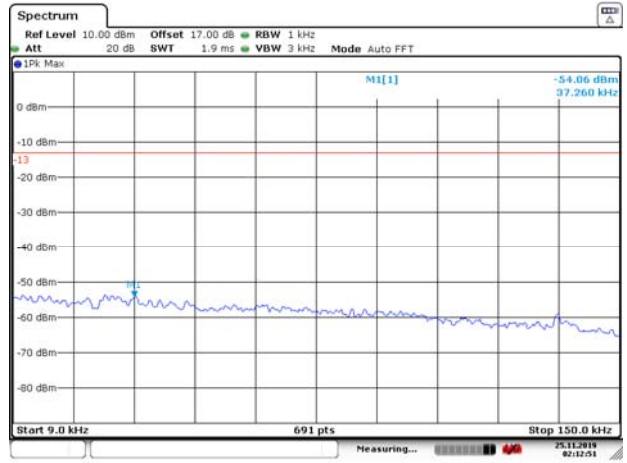

Date: 25.NOV.2019 02:12:51

GPRS 850 CH-High 150kHz ~ 30MHz

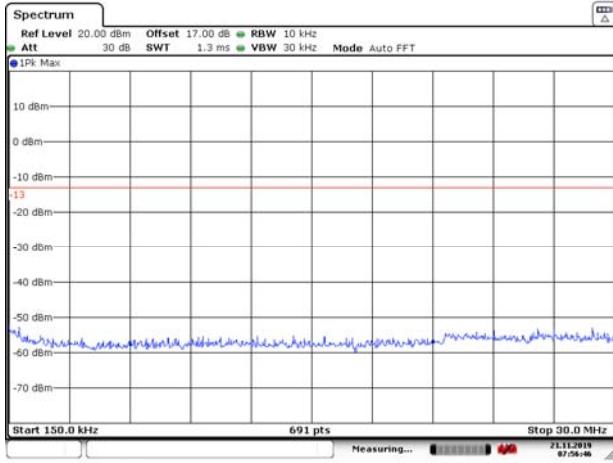

Date: 21.NOV.2019 07:56:47

EGPRS 850 CH-Low 150kHz ~ 30MHz

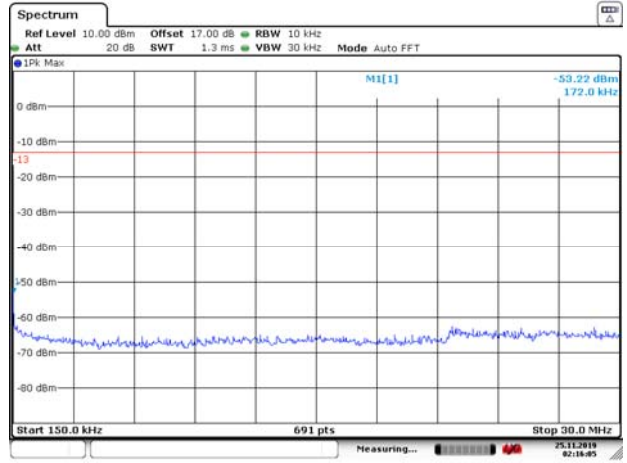

Date: 25.NOV.2019 02:16:06



GPRS 850 CH-High 30MHz ~ 1GHz

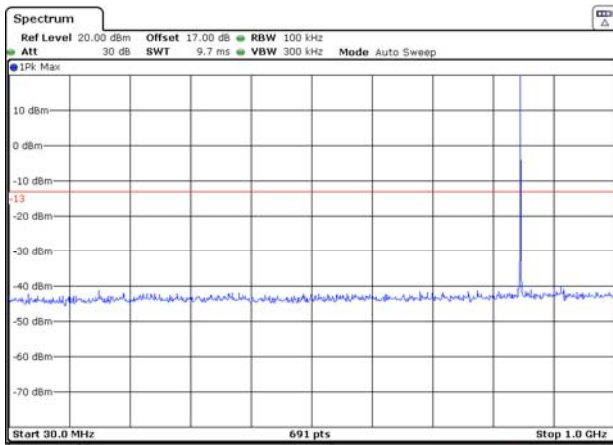

Date: 21.NOV.2019 07:57:14

EGPRS 850 CH-Low 30MHz ~ 1GHz

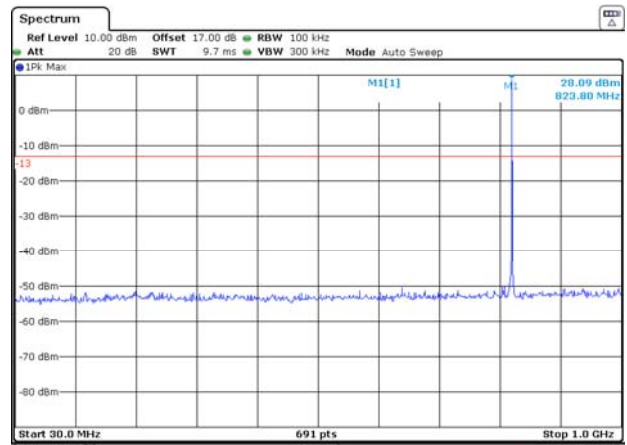

Date: 25.NOV.2019 02:18:06

GPRS 850 CH-High 1GHz ~ 9GHz

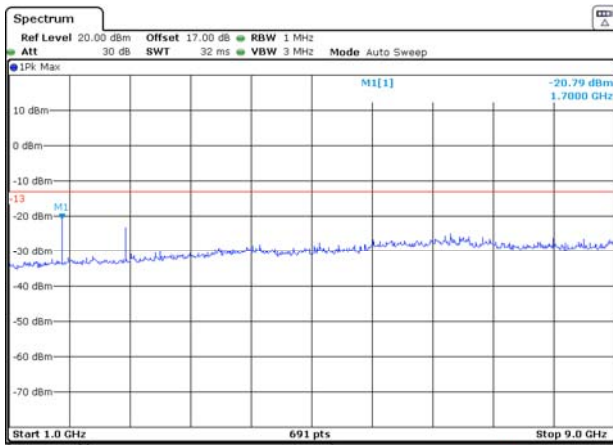

Date: 21.NOV.2019 07:59:41

EGPRS 850 CH-Low 1GHz ~ 9GHz

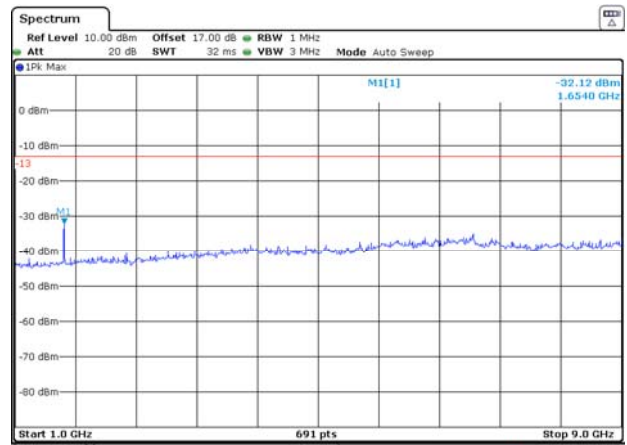

Date: 25.NOV.2019 02:19:09

EGPRS 850 CH- Middle 9kHz ~ 150kHz

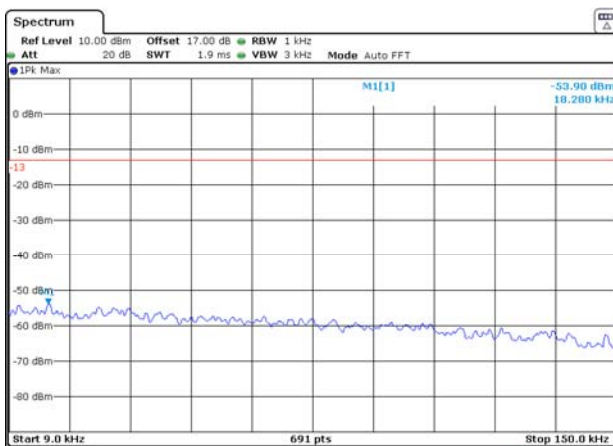

Date: 25.NOV.2019 02:13:26

EGPRS 850 CH-High 9kHz ~ 150kHz

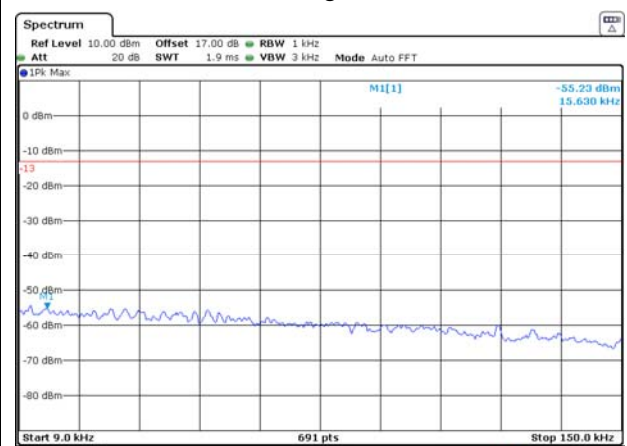

Date: 25.NOV.2019 02:13:56

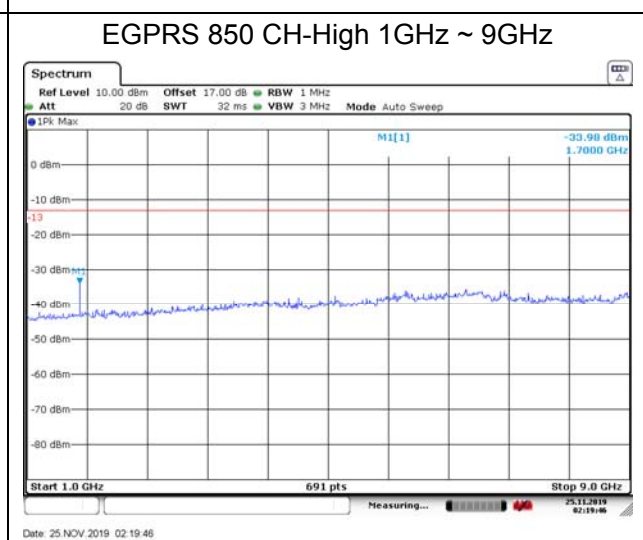
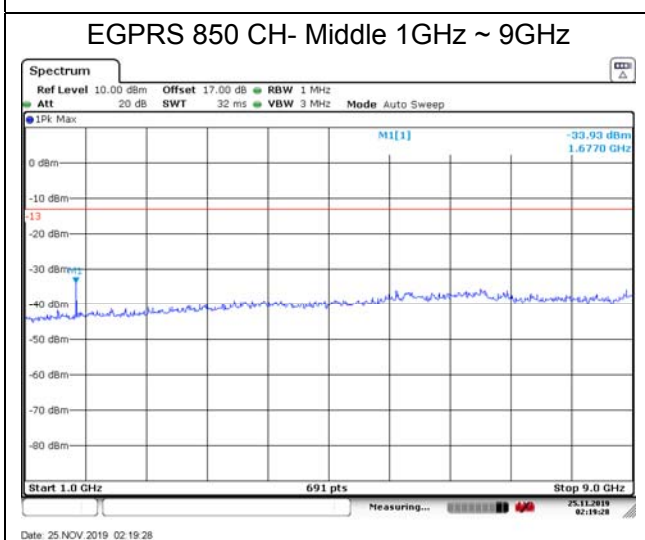
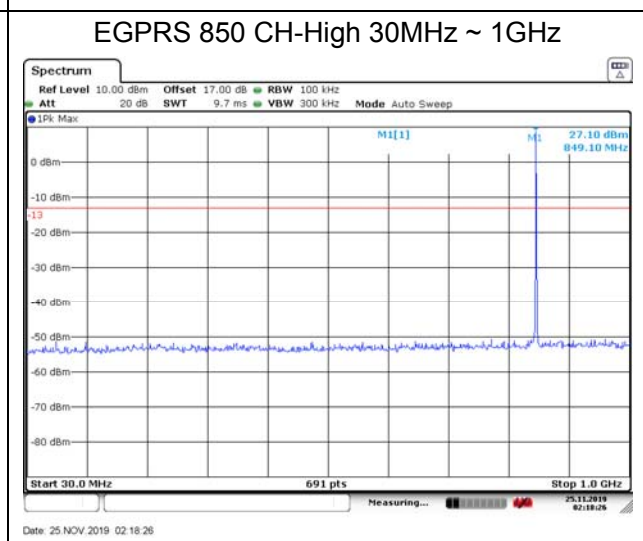
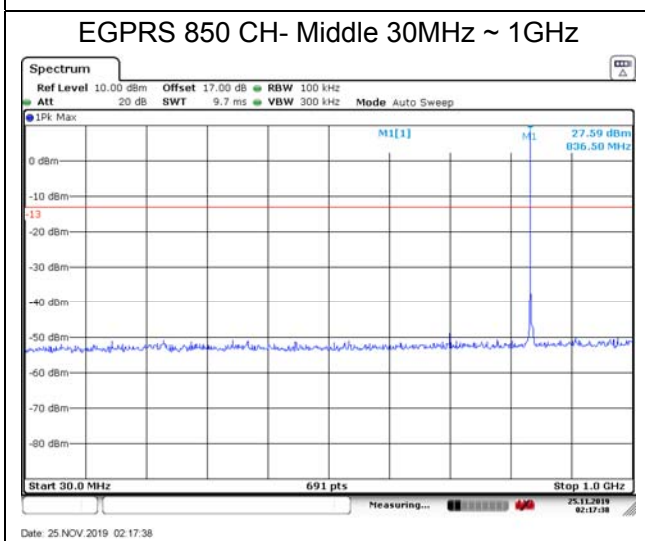
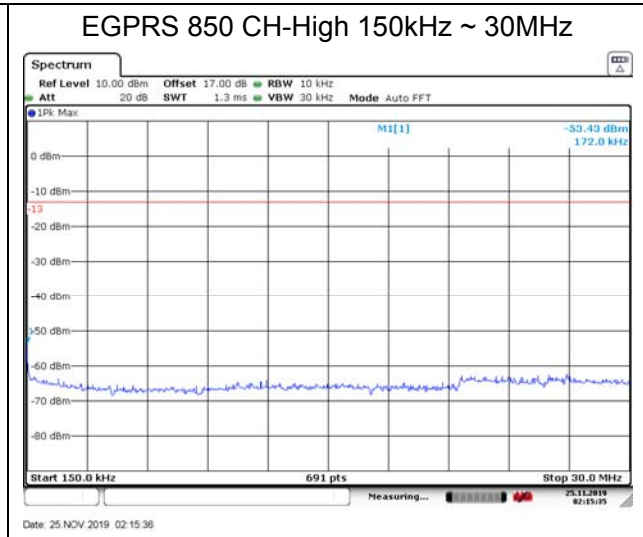
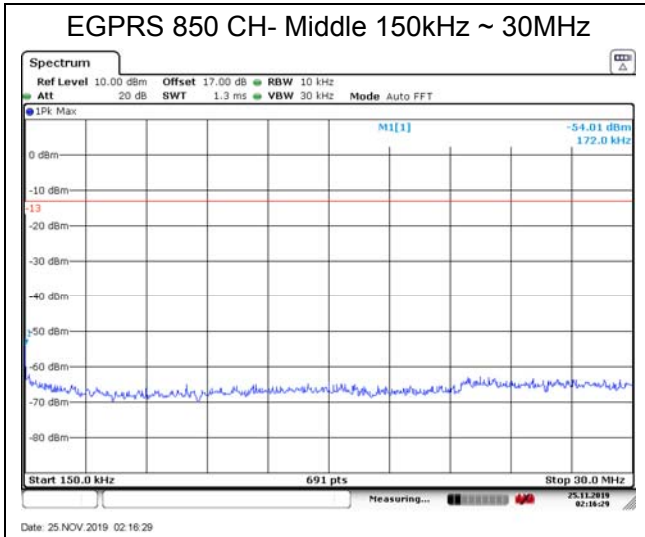

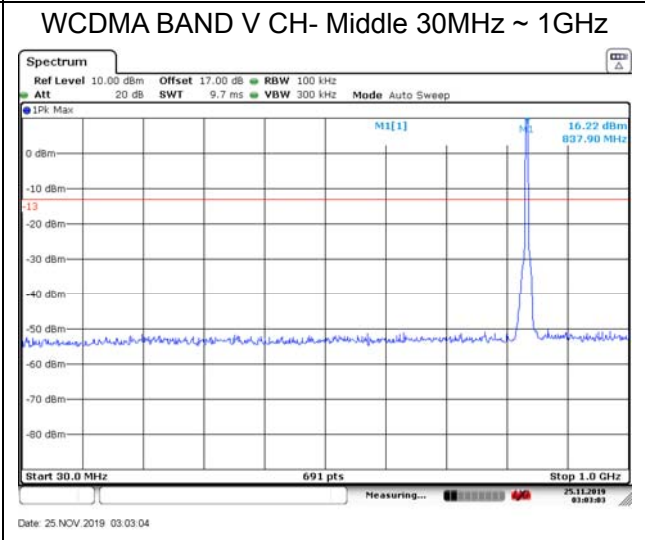
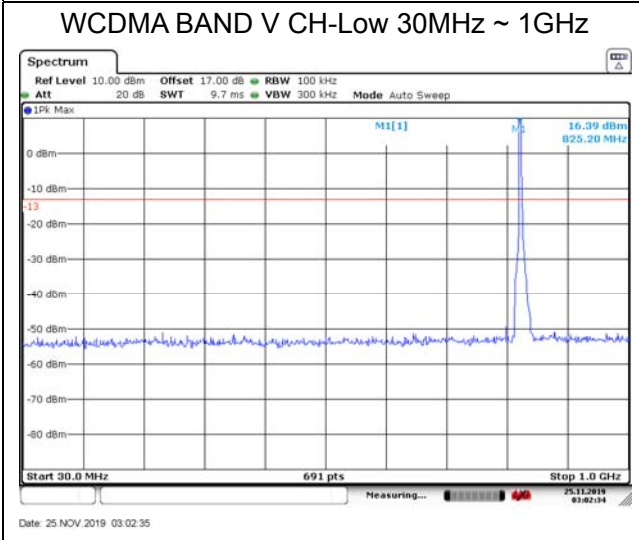
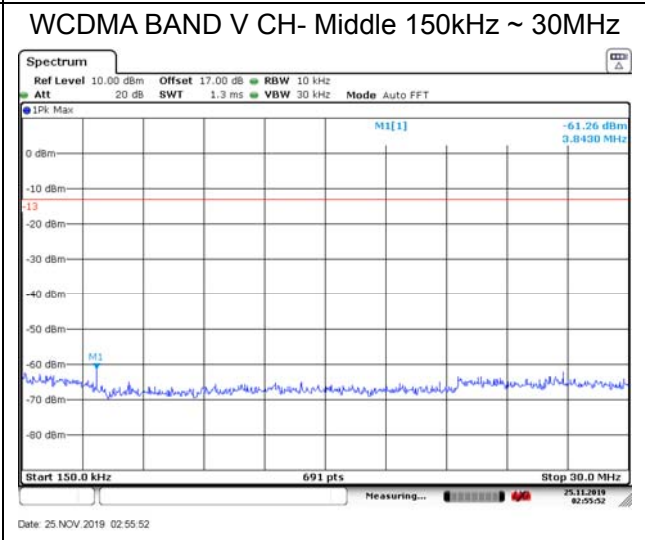
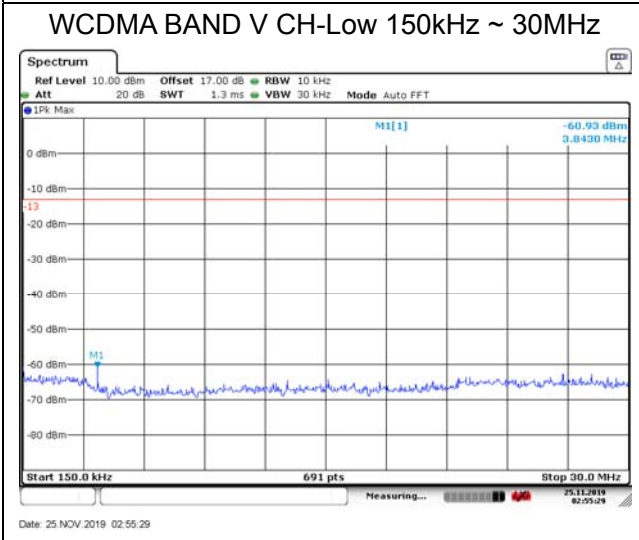
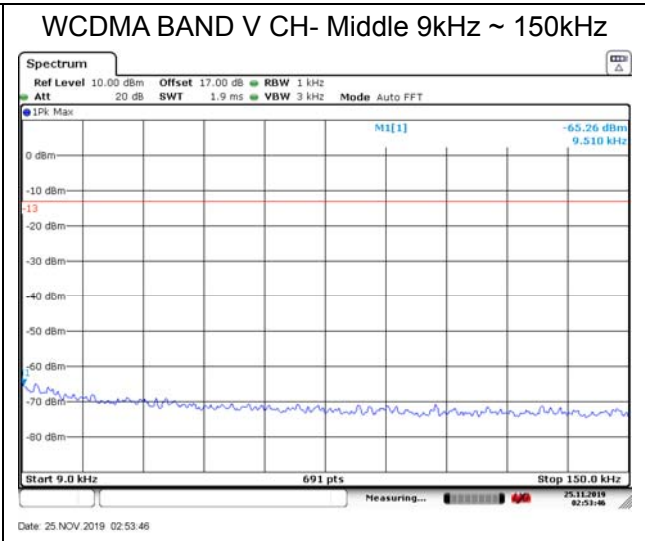
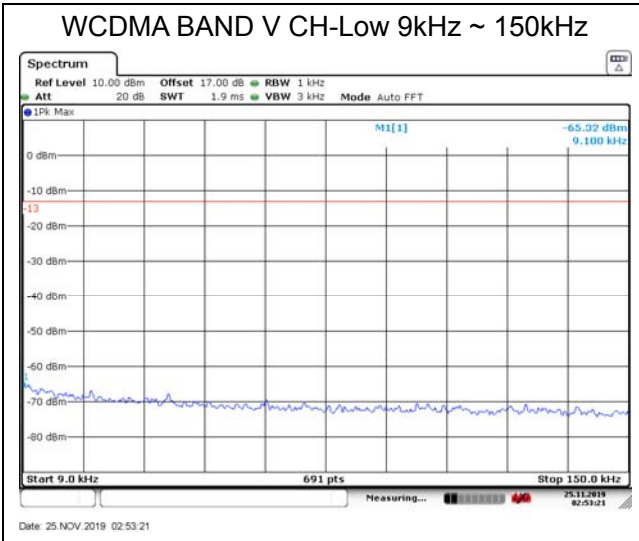

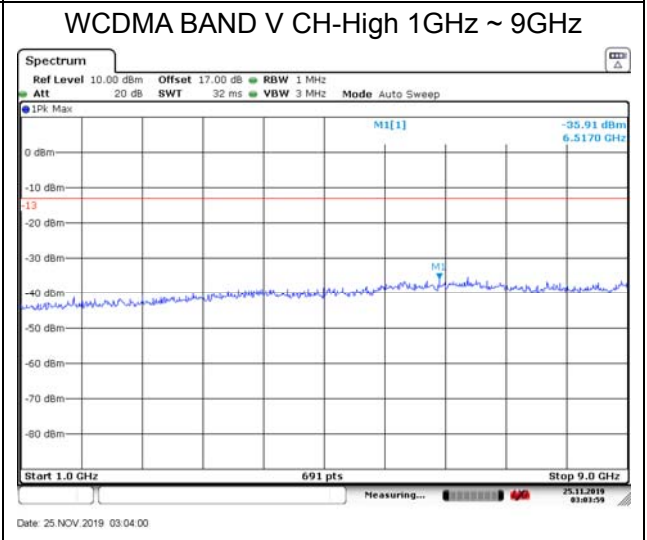
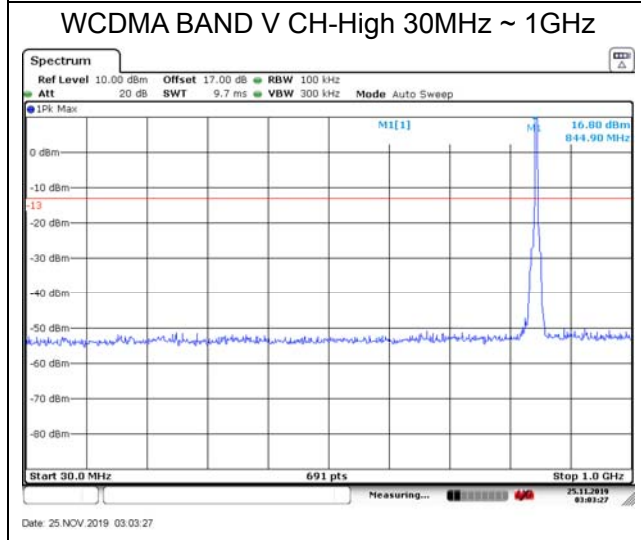
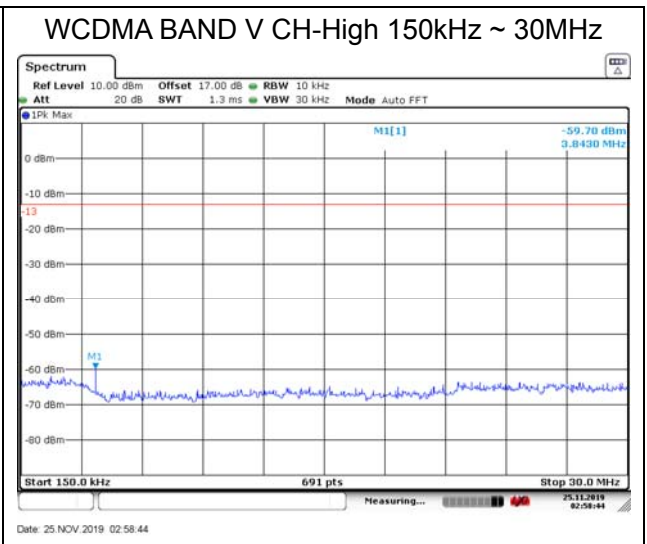
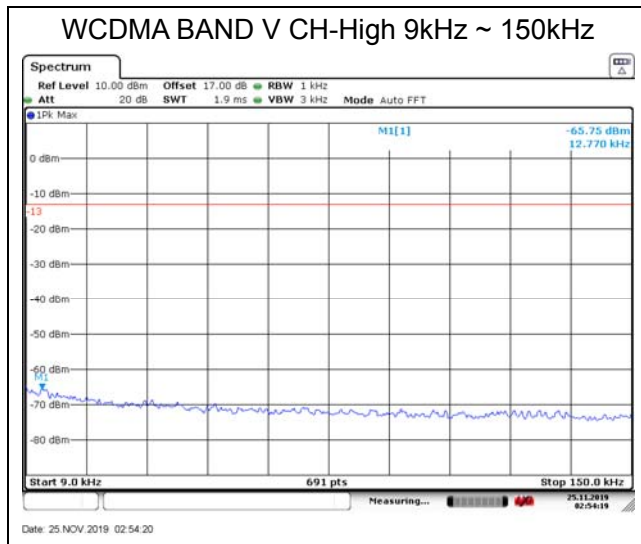
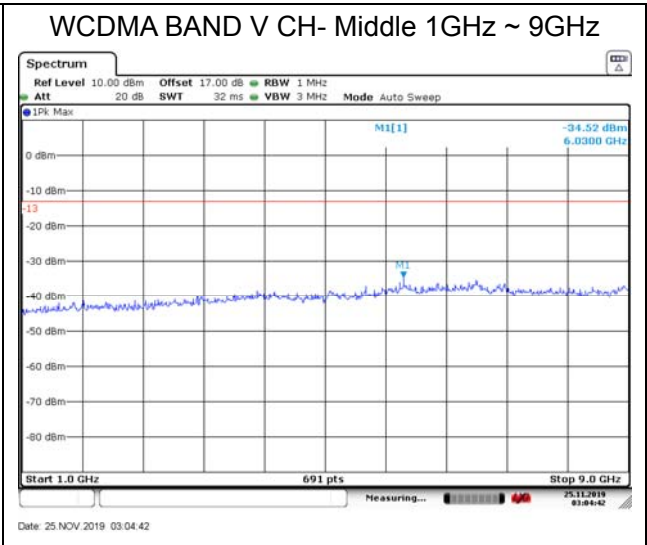
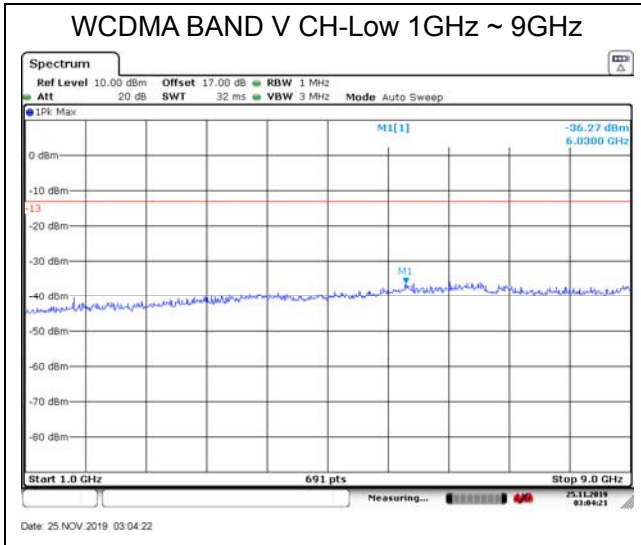

LTE Band 5 1.4MHz CH-Low 9kHz~10GHz

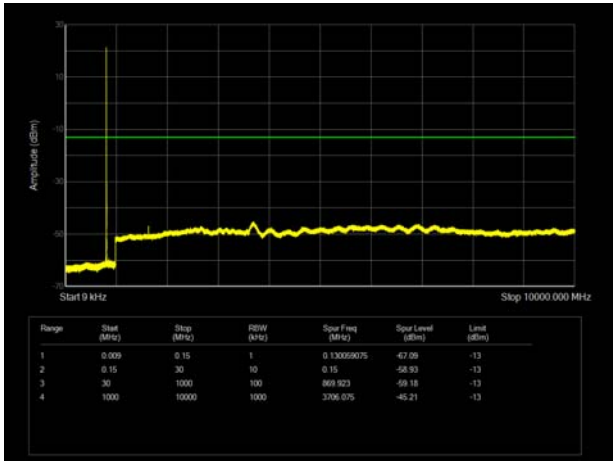

LTE Band 5 3MHz CH-Low 9kHz~10GHz

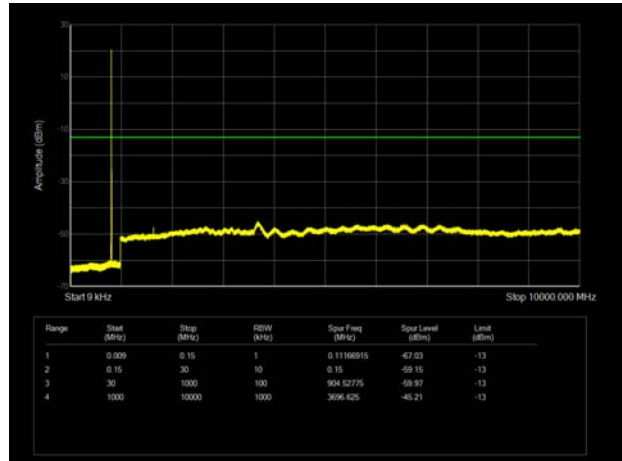

LTE Band 5 1.4MHz CH-Middle 9kHz~10GHz

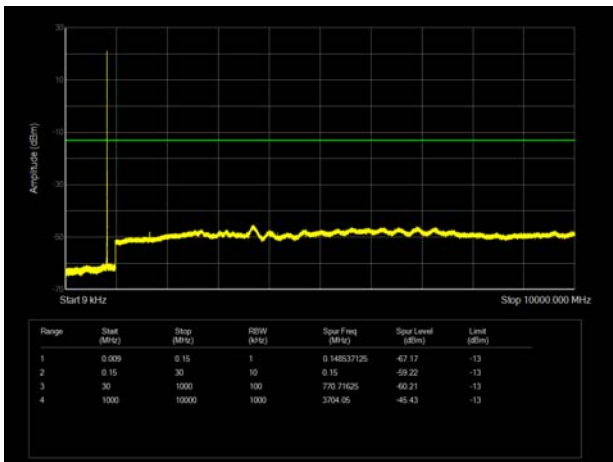

LTE Band 5 3MHz CH-Middle 9kHz~10GHz

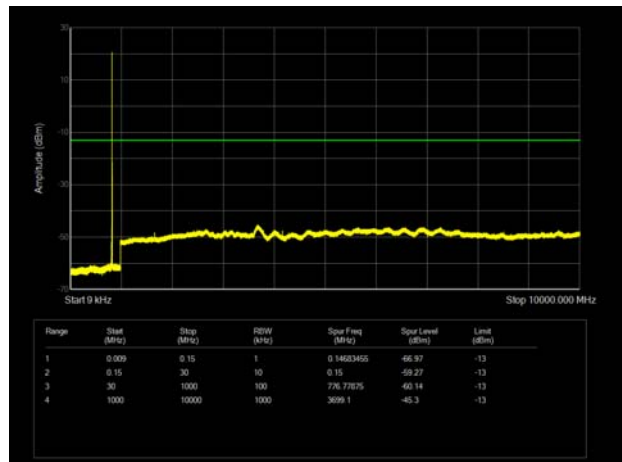

LTE Band 5 1.4MHz CH-High 9kHz~10GHz

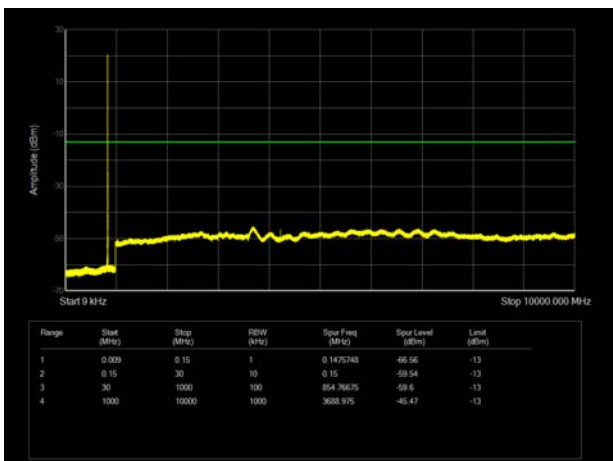

LTE Band 5 3MHz CH-High 9kHz~10GHz

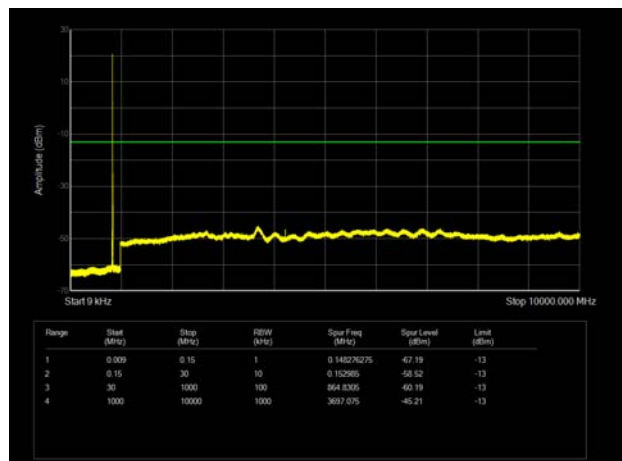

LTE Band 5 5MHz CH-Low 9kHz~10GHz

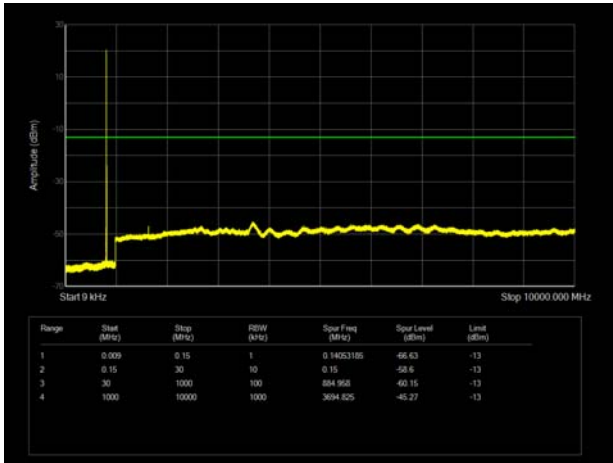

LTE Band 5 10MHz CH-Low 9kHz~10GHz

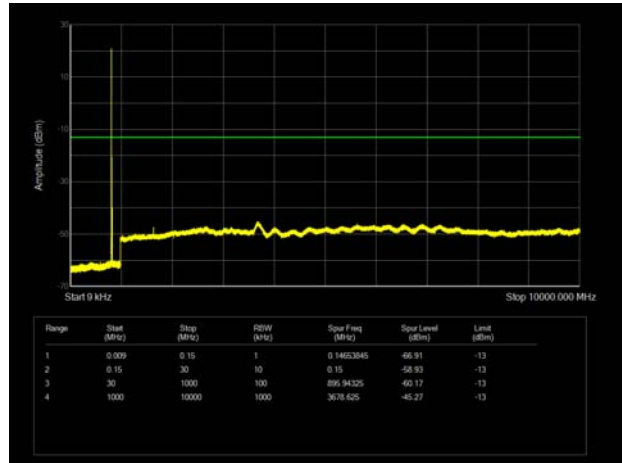

LTE Band 5 5MHz CH-Middle 9kHz~10GHz

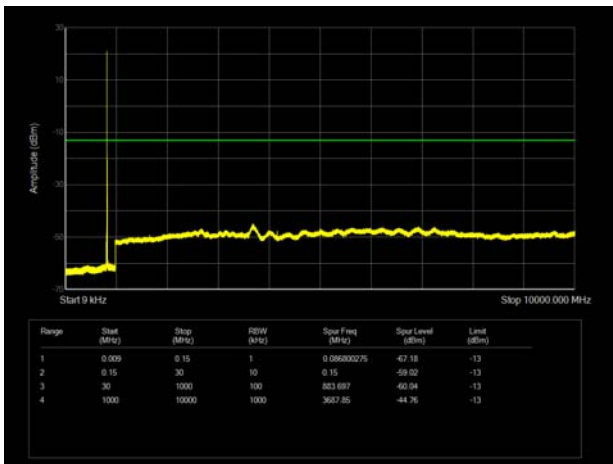

LTE Band 5 10MHz CH-Middle 9kHz~10GHz

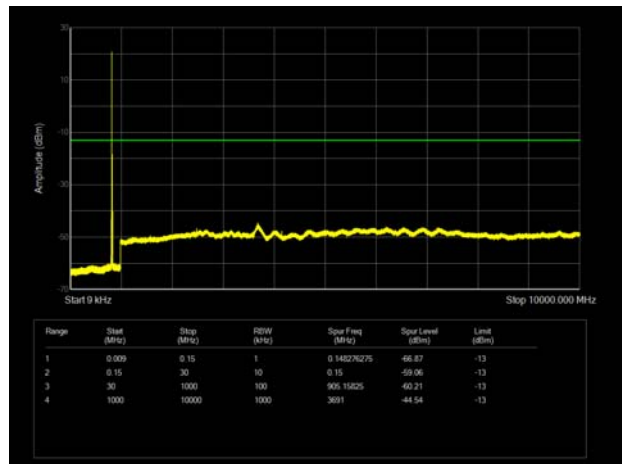

LTE Band 5 5MHz CH-High 9kHz~10GHz

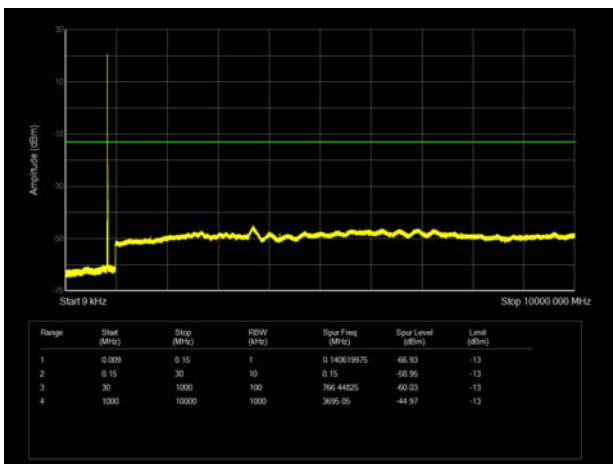

LTE Band 5 10MHz CH-High 9kHz~10GHz

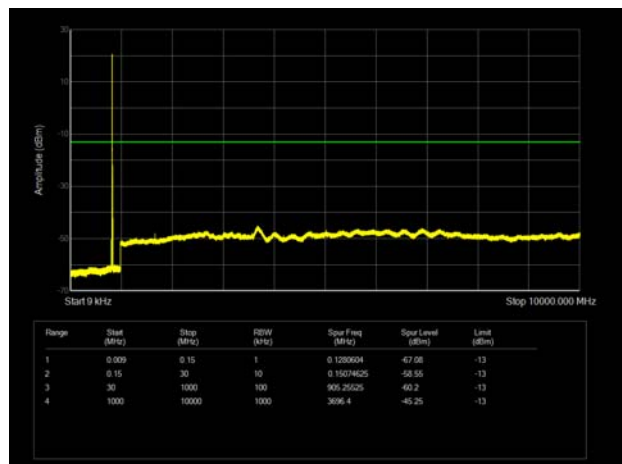

5.7. Radiates Spurious Emission

Ambient condition

Temperature	Relative humidity	Pressure
23°C ~25°C	45%~50%	101.5kPa

Method of Measurement

1. The testing follows FCC KDB 971168 v03r01 Section 5.8 and ANSI C63.26 (2015).
2. Below 1GHz: The EUT is placed on a turntable 0.8 meters above the ground in the chamber, 3 meter away from the antenna. The maximal emission value is acquired by adjusting the antenna height, polarisation and turntable azimuth. Normally, the height range of antenna is 1 m to 4 m, the azimuth range of turntable is 0° to 360°, and the receive antenna has two polarizations Vertical (V) and Horizontal (H). Above 1GHz: (Note: the FCC's permission to use 1.5m as an alternative per TCBC Conf call of Dec. 2, 2014.) The EUT is placed on a turntable 1.5 meters above the ground in the chamber, 3 meter away from the antenna. The maximal emission value is acquired by adjusting the antenna height, polarisation and turntable azimuth. Normally, the height range of antenna is 1 m to 4 m, the azimuth range of turntable is 0° to 360°, and the receive antenna has two polarizations Vertical (V) and Horizontal (H).
3. A loop antenna, A log-periodic antenna or horn antenna shall be substituted in place of the EUT. The log-periodic antenna will be driven by a signal generator and the level will be adjusted till the same power value on the spectrum analyzer or receiver. The level of the spurious emissions can be calculated through the level of the signal generator, cable loss, the gain of the substitution antenna and the reading of the spectrum analyzer or receiver.
4. The EUT is then put into continuously transmitting mode at its maximum power level during the test. Set Test Receiver or Spectrum RBW=200Hz,VBW=600Hz for 9kHz150kHz , RBW=10kHz, VBW=30kHz 150kHz-30MHz , RBW=100kHz,VBW=300kHz for 30MHz to 1GHz and RBW=1MHz, VBW=3MHz for above 1GHz, And the maximum value of the receiver should be recorded as (Pr).
5. The EUT shall be replaced by a substitution antenna. In the chamber, an substitution antenna for the frequency band of interest is placed at the reference point of the chamber. An RF Signal source for the frequency band of interest is connected to the substitution antenna with a cable that has been constructed to not interfere with the radiation pattern of the antenna. A power (PMea) is applied to the input of the substitution antenna, and adjust the level of the signal generator output until the value of the receiver reach the previously recorded (Pr). The power of signal source (PMea) is recorded. The test should be performed by rotating the test item and adjusting the receiving antenna polarization.
6. A amplifier should be connected to the Signal Source output port. And the cable should be connect between the Amplifier and the Substitution Antenna. The cable loss (Pcl) ,the Substitution Antenna Gain (Ga) and the Amplifier Gain (PAg) should be recorded after test.
7. The measurement results are obtained as described below:
Power(EIRP)=PMea- PAg - Pcl + Ga
The measurement results are amend as described below:
Power(EIRP)=PMea- Pcl + Ga
8. This value is EIRP since the measurement is calibrated using an antenna of known gain (2.15 dBi)

and known input power. ERP can be calculated from EIRP by subtracting the gain of the dipole, $ERP = EIRP - 2.15\text{dBi}$.

The modulation mode and RB allocation refer to section 5.1, using the maximum output power configuration.

Test setup

9KHz ~ 30MHz

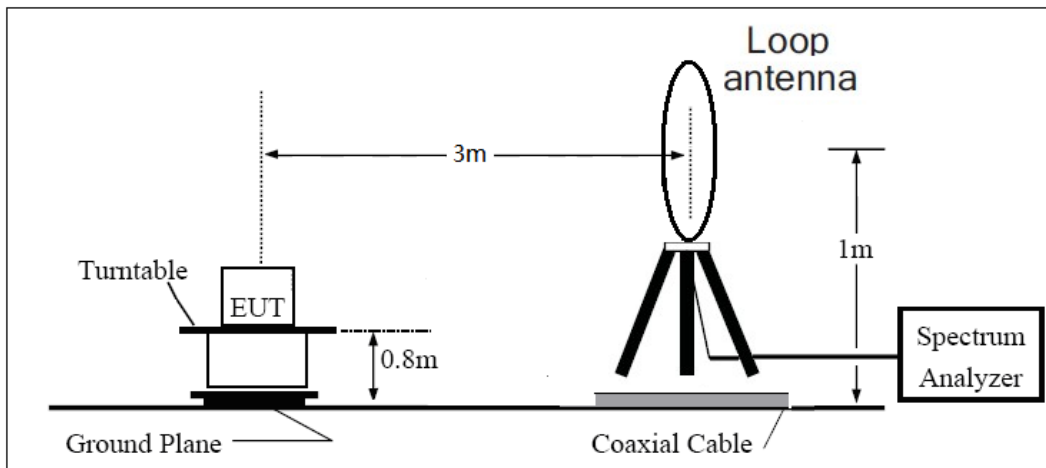

30MHz ~ 1GHz

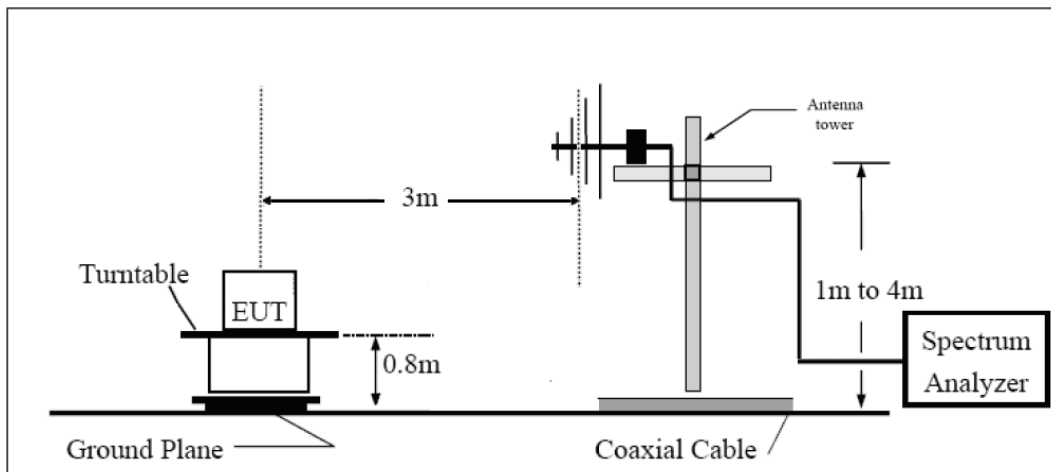

Above 1GHz

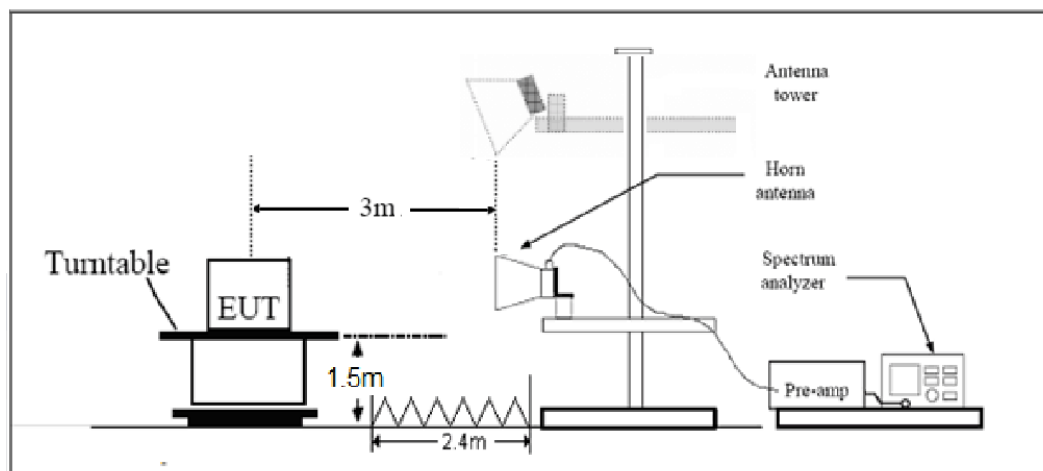



Note: Area side:2.4mX3.6m

Limits

Rule Part 22.917(a) specifies that “The power of any emission outside of the authorized operating frequency ranges must be attenuated below the transmitting power (P) by a factor of at least $43 + 10 \log (P)$ dB.”

Limit	-13 dBm
-------	---------

Measurement Uncertainty

The assessed measurement uncertainty to ensure 95% confidence level for the normal distribution is with the coverage factor $k = 1.96$, $U = 3.55$ dB.

**Test Result**

Sweep the whole frequency band through the range from 9kHz to the 10th harmonic of the carrier, the emissions below the noise floor will not be recorded in the report.

GSM 850 CH- Middle

Harmonic	Frequency (MHz)	SG (dBm)	Cable Loss (dB)	Gain (dBi)	Antenna Polarization	ERP Level (dBm)	Limit (dBm)	Margin (dB)	Azimuth (deg)
2	1673.4	-55.54	2.00	10.75	Horizontal	-48.94	-13.00	35.94	0
3	2510.4	-45.68	2.51	11.05	Horizontal	-39.29	-13.00	26.29	270
4	3346.4	-57.36	4.20	11.15	Horizontal	-52.56	-13.00	39.56	0
5	4183.0	-53.87	5.20	11.15	Horizontal	-50.07	-13.00	37.07	180
6	5019.6	-53.64	5.50	11.95	Horizontal	-49.34	-13.00	36.34	315
7	5856.2	-54.95	5.70	13.55	Horizontal	-49.25	-13.00	36.25	90
8	6692.8	-55.95	6.30	13.75	Horizontal	-50.65	-13.00	37.65	135
9	7529.4	-52.36	6.80	13.85	Horizontal	-47.46	-13.00	34.46	180
10	8366.0	-52.35	6.90	14.25	Horizontal	-47.15	-13.00	34.15	270

Note: 1.The other Spurious RF Radiated emissions level is no more than noise floor.

2.The worst emission was found in the antenna is Horizontal position.

WCDMA Band V CH-Middle

Harmonic	Frequency (MHz)	SG (dBm)	Cable Loss (dB)	Gain (dBi)	Antenna Polarization	ERP Level (dBm)	Limit (dBm)	Margin (dB)	Azimuth (deg)
2	1673.2	-61.03	2.00	10.75	Horizontal	-54.43	-13.00	41.43	135
3	2509.8	-59.09	2.51	11.05	Horizontal	-52.70	-13.00	39.70	225
4	3346.4	-57.96	4.20	11.15	Horizontal	-53.16	-13.00	40.16	315
5	4183.0	-53.85	5.20	11.15	Horizontal	-50.05	-13.00	37.05	90
6	5019.6	-54.32	5.50	11.95	Horizontal	-50.02	-13.00	37.02	0
7	5856.2	-55.90	5.70	13.55	Horizontal	-50.20	-13.00	37.20	45
8	6692.8	-56.81	6.30	13.75	Horizontal	-51.51	-13.00	38.51	180
9	7529.4	-52.74	6.80	13.85	Horizontal	-47.84	-13.00	34.84	270
10	8366.0	-52.21	6.90	14.25	Horizontal	-47.01	-13.00	34.01	135

Note: 1.The other Spurious RF Radiated emissions level is no more than noise floor.

2.The worst emission was found in the antenna is Horizontal position.



LTE Band 5 1.4MHz CH-Middle

Harmonic	Frequency (MHz)	SG (dBm)	Cable Loss (dB)	Gain (dBi)	Antenna Polarization	ERP Level (dBm)	Limit (dBm)	Margin (dB)	Azimuth (deg)
2	1673.0	-61.63	2.00	10.75	Horizontal	-55.03	-13.00	42.03	270
3	2509.5	-56.99	2.51	11.05	Horizontal	-50.60	-13.00	37.60	0
4	3346.0	-59.59	4.20	11.15	Horizontal	-54.79	-13.00	41.79	90
5	4182.5	-54.91	5.20	11.15	Horizontal	-51.11	-13.00	38.11	90
6	5019.0	-58.16	5.50	11.95	Horizontal	-53.86	-13.00	40.86	180
7	5855.5	-59.11	5.70	13.55	Horizontal	-53.41	-13.00	40.41	45
8	6692.0	-58.35	6.30	13.75	Horizontal	-53.05	-13.00	40.05	315
9	7528.5	-56.11	6.80	13.85	Horizontal	-51.21	-13.00	38.21	135
10	8365.0	-54.55	6.90	14.25	Horizontal	-49.35	-13.00	36.35	45

Note: 1.The other Spurious RF Radiated emissions level is no more than noise floor.
2.The worst emission was found in the antenna is Horizontal position.

LTE Band 5 5MHz CH-Middle

Harmonic	Frequency (MHz)	SG (dBm)	Cable Loss (dB)	Gain (dBi)	Antenna Polarization	ERP Level (dBm)	Limit (dBm)	Margin (dB)	Azimuth (deg)
2	1673.0	-57.20	2.00	10.75	Horizontal	-50.60	-13.00	37.60	90
3	2509.5	-59.21	2.51	11.05	Horizontal	-52.82	-13.00	39.82	135
4	3466.2	-58.84	4.20	11.15	Horizontal	-54.04	-13.00	41.04	180
5	4215.9	-52.24	5.20	11.15	Horizontal	-48.44	-13.00	35.44	90
6	5165.6	-58.35	5.50	11.95	Horizontal	-54.05	-13.00	41.05	0
7	5815.3	-60.26	5.70	13.55	Horizontal	-54.56	-13.00	41.56	315
8	6765.0	-57.44	6.30	13.75	Horizontal	-52.14	-13.00	39.14	135
9	7614.7	-53.91	6.80	13.85	Horizontal	-49.01	-13.00	36.01	180
10	8464.4	-55.42	6.90	14.25	Horizontal	-50.22	-13.00	37.22	90

Note: 1.The other Spurious RF Radiated emissions level is no more than noise floor.
2.The worst emission was found in the antenna is Horizontal position.



LTE Band 5 10MHz CH-Middle

Harmonic	Frequency (MHz)	SG (dBm)	Cable Loss (dB)	Gain (dBi)	Antenna Polarization	ERP Level (dBm)	Limit (dBm)	Margin (dB)	Azimuth (deg)
2	1673.0	-59.23	2.00	10.75	Horizontal	-52.63	-13.00	39.63	315
3	2509.5	-56.91	2.51	11.05	Horizontal	-50.52	-13.00	37.52	45
4	3346.0	-53.49	4.20	11.15	Horizontal	-48.69	-13.00	35.69	45
5	4182.5	-47.68	5.20	11.15	Horizontal	-43.88	-13.00	30.88	135
6	5019.0	-57.93	5.50	11.95	Horizontal	-53.63	-13.00	40.63	180
7	5855.5	-59.51	5.70	13.55	Horizontal	-53.81	-13.00	40.81	0
8	6692.0	-56.85	6.30	13.75	Horizontal	-51.55	-13.00	38.55	315
9	7528.5	-55.27	6.80	13.85	Horizontal	-50.37	-13.00	37.37	180
10	8365.0	-55.15	6.90	14.25	Horizontal	-49.95	-13.00	36.95	90

Note: 1.The other Spurious RF Radiated emissions level is no more than noise floor.

2.The worst emission was found in the antenna is Horizontal position.

6. Main Test Instruments

Name	Manufacturer	Type	Serial Number	Calibration Date	Expiration Date
Base Station Simulator	R&S	CMW500	113824	2019-05-19	2020-05-18
Power Splitter	Hua Xiang	SHX-GF2-2-13	10120101	/	/
Spectrum Analyzer	Key sight	N9010A	MY50210259	2019-05-19	2020-05-18
Universal Radio Communication Tester	Key sight	E5515C	MY48367192	2019-05-19	2020-05-18
Signal Analyzer	R&S	FSV30	100815	2018-12-16	2019-12-15
Loop Antenna	SCHWARZBECK	FMZB1519	1519-047	2017-09-26	2020-09-25
Trilog Antenna	SCHWARZBECK	VUBL 9163	9163-201	2017-11-18	2020-11-17
Horn Antenna	R&S	HF907	100126	2018-07-07	2020-07-06
Horn Antenna	ETS-Lindgren	3160-09	00102643	2018-06-20	2020-06-19
Signal generator	R&S	SMB 100A	102594	2019-05-19	2020-05-18
Climatic Chamber	ESPEC	SU-242	93000506	2017-12-17	2020-12-16
Preamplifier	R&S	SCU18	102327	2019-05-19	2020-05-18
MOB COMMS DC SUPPLY	Keysight	66319D	MY43004105	2019-05-20	2020-05-21
RF Cable	Agilent	SMA 15cm	0001	2019-06-14	2019-12-13
Software	R&S	EMC32	9.26.0	/	/

*****END OF REPORT *****