

**Industrial Internet Innovation Center (Shanghai) Co.,Ltd.**

**SRD TEST REPORT**

<b>PRODUCT</b>	POS System
<b>BRAND</b>	SUNMI
<b>MODEL</b>	F3510
<b>APPLICANT</b>	Shanghai Sunmi Technology Co.,Ltd.
<b>FCC ID</b>	2AH25D3PRO
<b>IC</b>	22621-D3PRO
<b>ISSUE DATE</b>	March 22, 2024
<b>STANDARD(S)</b>	FCC Part15E, RSS-247 Issue 3, RSS-Gen Issue 5

Prepared by: *Tao Lingyan*



Reviewed by: *Yang Fan*

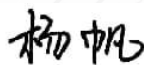

Approved by: *Zhang Min*



**CAUTION:**

*This report shall not be reproduced except in full without the written permission of the test laboratory and shall not be quoted out of context.*

## CONTENTS

<b>1. SUMMARY OF TEST REPORT .....</b>	<b>3</b>
1.1 TEST STANDARD(S) .....	3
1.2 REFERENCE DOCUMENTS.....	3
1.3 SUMMARY OF TEST RESULTS.....	3
1.4 DATA PROVIDED BY APPLICANT.....	4
<b>2. GENERAL INFORMATION OF THE LABORATORY .....</b>	<b>5</b>
2.1 TESTING LABORATORY .....	5
2.2 LABORATORY ENVIRONMENTAL REQUIREMENTS.....	5
2.3 PROJECT INFORMATION.....	5
<b>3. GENERAL INFORMATION OF THE CUSTOMER .....</b>	<b>6</b>
3.1 APPLICANT .....	6
3.2 MANUFACTURER .....	6
<b>4. GENERAL INFORMATION OF THE PRODUCT.....</b>	<b>7</b>
4.1 PRODUCT DESCRIPTION FOR EQUIPMENT UNDER TEST (EUT).....	7
4.2 INTERNAL IDENTIFICATION OF AE USED DURING THE TEST.....	7
4.3 ADDITIONAL INFORMATION .....	7
<b>5. TEST CONFIGURATION INFORMATION .....</b>	<b>9</b>
5.1 LABORATORY ENVIRONMENTAL CONDITIONS.....	9
5.2 TEST EQUIPMENTS UTILIZED.....	9
5.3 MEASUREMENT UNCERTAINTY .....	11
<b>6. MEASUREMENT RESULTS .....</b>	<b>13</b>
6.1 DUTY CYCLE .....	13
6.2 MAXIMUM AVERAGE OUTPUT POWER .....	16
6.3 PEAK POWER SPECTRAL DENSITY .....	20
6.4 6dB OCCUPIED BANDWIDTH.....	24
6.5 99% OCCUPIED BANDWIDTH.....	30
6.6 FREQUENCY STABILITY .....	33
6.7 TRANSMITTER SPURIOUS EMISSION.....	34
6.8 BAND EDGES COMPLIANCE (RADIATED) .....	52
6.9 AC POWERLINE CONDUCTED EMISSION .....	58
<b>ANNEX A: REVISED HISTORY .....</b>	<b>61</b>
<b>ANNEX B: ACCREDITATION CERTIFICATE.....</b>	<b>62</b>



## 1. Summary of Test Report

### 1.1 Test Standard(s)

No.	Test Standard	Title	Version
1	FCC Part15E	Title 47 of the Code of Federal Regulations; Chapter I Part 15 - Radio frequency devices	--
2	RSS-247 Issue 3	Digital Transmission Systems (DTSSs), Frequency Hopping Systems (FHSs) and Licence-Exempt Local Area Network (LE-LAN) Devices	2023
3	RSS-Gen Issue 5	General Requirements for Compliance of Radio Apparatus	2021

### 1.2 Reference Documents

No.	Test Standard	Title	Version
1	ANSI 63.10	Methods of Measurement of Radio-Noise Emissions from Low-Voltage Electrical and Electronic Equipment in the Range of 9 kHz to 40 GHz	2013
2	KDB 789033 D02 General UNII Test Procedures New Rules v02r01	Guidelines For Compliance Testing Of Unlicensed National Information Infrastructure (U-Nii) Devices (Part 15, Subpart E)	--

Note: KDB 789033 D02 General UNII Test Procedures New Rules v02r01 is not A2LA certified.

### 1.3 Summary of Test Results

No.	Measurement Items	FCC Rules	IC Rules	Verdict
1	Duty cycle	15.407(a)	RSS-247 6.2.4.2	Pass
2	Maximum Output Power	15.407(a)	RSS-247 6.2.4.2	Pass
3	Power Spectral Density	15.407(a)	RSS-247 6.2.4.2	Pass
4	6dB Occupied Bandwidth	15.407(e)	RSS-247 6.2.4.2	Pass
5	99% Occupied Bandwidth	15.407(e)	RSS-GEN 6.7	Pass
6	Band edge compliance	15.407(b)	RSS-247 6.2.4.3	Pass
7	Transmitter Spurious Emission - Radiated	15.407/15.205/15.209	RSS-247 6.2, RSS-Gen 8.9,8.10	Pass
8	AC Powerline Conducted Emission	15.207	RSS-GEN 8.8	Pass
9	Frequency Stability	15.407(g)	RSS-GEN 8.11	Pass
10	Antenna requirement	15.203/15.247(c)	RSS Gen 6.8, RSS-247 5.4	Pass

**Note 1:**

The F3510 manufactured by Shanghai Sunmi Technology Co.,Ltd. is a new product for testing. There are two configurations S02aa (Mainly Supply) & S11aa (Secondary Supply) in this project. We mainly tested the S02aa (Mainly Supply), and S11aa (Secondary Supply) tested the worst mode of the main supply, and recorded the test results of the worst mode respectively in the report.

The description of the differences between S02aa (Mainly Supply) & S11aa (Secondary Supply) are as follows:

EUT ID	FCC ID number	IC number	HVIN	Fingerprint
S02aa (Mainly Supply)	2AH25D3PRO	22621-D3PRO	F3510	Yes
S11aa (Secondary Supply)			F3510A	N/A

Industrial Internet Innovation Center (Shanghai) Co., Ltd. only performed test cases which identified with Pass/Fail/Inc result in section 1.3.

Industrial Internet Innovation Center (Shanghai) Co., Ltd. has verified that the compliance of the tested device specified in section 4 of this test report is successfully evaluated according to the procedure and test methods as defined in type certification requirement listed in section 1 of this test report.

Note 2:

5.8G WLAN used a FPC antenna with max Gain 2.80 dBi that complied with 15.203 Requirements.

#### 1.4 Data Provided by Applicant

No.	Item(s)	Data
1	Antenna gain of EUT	2.80 dBi

Note: The data of antenna gain is provided by the Antenna specification may affect the validity of the test results in this report, and the impact and consequences of this shall be undertaken by the customer.



## 2. General Information of The Laboratory

### 2.1 Testing Laboratory

Lab Name	Industrial Internet Innovation Center (Shanghai) Co.,Ltd.
Address	Building 4, No. 766, Jingang Road, Pudong, Shanghai, China
Telephone	021-68866880
FCC Registration No.	708870
FCC Designation No.	CN1364
IC Designation No.	10766A
CAB identifier	CN0067

### 2.2 Laboratory Environmental Requirements

Temperature	15°C~35°C
Relative Humidity	25%RH~75%RH
Atmospheric Pressure	86kPa~106kPa

### 2.3 Project Information

Project Manager	Gao Hongning
Test Date	January 31, 2024 to March 14, 2024

### 3. General Information of The Customer

#### 3.1 Applicant

Company	Shanghai Sunmi Technology Co.,Ltd.
Address	Room 505,No.388,Song Hu Road,Yang Pu District,Shanghai,China
Telephone	+86 17302160204

#### 3.2 Manufacturer

Company	Shanghai Sunmi Technology Co.,Ltd.
Address	Room 505,No.388,Song Hu Road,Yang Pu District,Shanghai,China
Telephone	+86 17302160204



## 4. General Information of The Product

### 4.1 Product Description for Equipment under Test (EUT)

Product Name	POS System
Model name	F3510
Date of Receipt	S05aa/S02aa:January 31,2024 S09aa:February 21,2024 S11aa:February 22,2024
EUT ID*	S05aa/S09aa/S02aa/S11aa
SN/IMEI	S05aa: DP02D41R10015 S09aa: DP02D41R10035 S02aa: DP02D41R10008 S11aa:DP01D41N10086
Supported Radio Technology and Bands	BT 5.0 BR/EDR/BLE WLAN 802.11b,g,n WLAN 802.11a,n,ac
Hardware Version	SD03_MB V1.1
Software Version	1.0.0
FCC ID	2AH25D3PRO
IC	22621-D3PRO

NOTE1:EUT ID is the internal identification code of the laboratory.

NOTE2: Samples in the test report are provided by the customer. The test results are only applicable to the samples received by the laboratory.

### 4.2 Internal Identification of AE used during the test

AE ID*	Description	Model	SN/Remark
CA02	Adapter	CYZS36-240150	Jiangsu Chenyang Electron Co., Ltd. 24V,1.5A
UA02	AC Cable	N/A	N/A

NOTE: \*AE ID is the internal identification code of the laboratory.

### 4.3 Additional Information

WLAN Frequency	UNII 3: 5725MHz-5850MHz
Occupied Channel Bandwidth	20 MHz for Wi-Fi (802.11 a/n/ac) 40 MHz for Wi-Fi (802.11 n/ac) 80 MHz for Wi-Fi(802.11 ac)
WLAN type of modulation	OFDM

Test frequency list:

UNII-3:

BW_20M	Channel	149	153	157	161	165
	Freq. (MHz)	5745	5765	5785	5805	5825
BW_40M	Channel	151		159		/
	Freq. (MHz)	5755		5795		
BW_80M	Channel	155				
	Freq. (MHz)	5775				

Note: "/" Represents empty

Note: This report is for WLAN UNII-3 only.



## 5. Test Configuration Information

### 5.1 Laboratory Environmental Conditions

#### 5.1.1 Permanent Facilities

Relative Humidity	Min. = 45 %, Max. = 55 %		
Atmospheric Pressure	101kPa		
Temperature	Normal	Minimum	Maximum
	25°C	-10°C	40°C
Working Voltage of EUT	Normal	Minimum	Maximum
	24V	22.8V	25.2V

### 5.2 Test Equipments Utilized

#### 5.2.1 Conducted Test System

No.	Name	Model	S/N	SW Version	HW Version	Manufacturer	Cal. Date	Cal. Interval
1	Test Software	TS1120	10727	V3.2.22	N/A	Tonscend	N/A	N/A
2	Automatic control unit	JS0806-2	2218060623	N/A	N/A	Tonscend	2023-05-06	1 Year
3	Wireless communication comprehensive tester	CMW500	164865	V3.8.12	N/A	R&S	2023-07-26	1 Year
4	Spectrum Analyzer	FSQ40	200063	V4.75	N/A	R&S	2023-10-16	1 Year
5	Analog Signal Generator	SMF	104770	V3.0.13.0-2.20.530.15.4	N/A	R&S	2023-10-16	1 year
6	Vector Signal Generator	SMCV100B	103691	V5.00.122.24	N/A	R&S	2023-07-27	1 Year
7	Programmable Power Supply	Keithley 2303	4039070	N/A	N/A	Keithley	2023-06-23	1 Year
8	Temperature box	B-TF-107C	BTF107C-201804107	N/A	N/A	Boyi	2023-06-28	1 Year
9	Network test unit AP	GT-AXE11000	N2IG0X401637KWF	V3.0.0.4.386_45940	N/A	ASUS	N/A	N/A
10	Vector Signal Generator	SMBV100A	257904	V4.15.125.49	N/A	R&S	2023-10-16	1 Year

**5.2.2 Radiated Emission Test System**

No	Name	Model	S/N	SW Version	HW Version	Manufacturer	Cal. Date	Cal. Interval
1	Universal Radio Communication Tester	CMU200	123126	V5.2.1	B12	R&S	2023-10-16	1 Year
2	Universal Radio Communication Tester	CMW500	104178	V3.7.20	1206.0600.00	R&S	2023-10-16	1 Year
3	EMI Test Receiver	ESU40	100307	V5.1-24-3	01	R&S	2023-12-19	1 Year
4	TRILOG Broadband Antenna	VULB9163	01345	N/A	N/A	Schwarzbeck	2023-03-23	1 Year
5	Double-ridged Waveguide Antenna	ETS-3117	00135890	N/A	N/A	ETS	2022-03-09	2 Years
6	EMI Test Software	EMC32 V10.35.02	N/A	N/A	N/A	R&S	N/A	N/A
7	Horn Antenna	3160-09	LM6321	N/A	N/A	R&S	2023-07-16	1 Year
8	Horn Antenna	3160-10	LM5942	N/A	N/A	R&S	2023-07-16	1 Year
9	Loop Antenna	AL-130R	121083	N/A	N/A	COM-POWER	2023-9-13	1 Year
10	Preamplifier	SCU08F1	8320024	N/A	N/A	R&S	2023-10-16	1 Year
11	Preamplifier	SCU18	10155	N/A	N/A	R&S	2023-10-16	1 Year
12	Preamplifier	SCU26	10025	N/A	N/A	R&S	2023-10-16	1 Year
13	Preamplifier	SCU40	10020	N/A	N/A	R&S	2023-10-16	1 Year
14	2-Line V-Network	ENV216	101380	N/A	N/A	R&S	2023-12-19	1 Year
15	EMI Test Software	EMC32 V10.35.02	N/A	N/A	N/A	R&S	N/A	N/A
16	Test Receiver	ESCI	101235	V5.1-24-3	0	R&S	2023-12-19	1 Year

Note: After 2024-3-9, the Double-ridged Waveguide Antenna of this device is not used for radiation testing.



### 5.2.3 Test Environment

**Shielding Room1** (6.0 meters×3.0 meters×2.7 meters) did not exceed following limits along the conducted RF performance testing:

Temperature	Min. = 15 °C, Max. = 35 °C
Relative humidity	Min. = 20 %, Max. = 75 %
Shielding effectiveness	> 100 dB
Ground system resistance	< 0.5 Ω
Temperature	Min. = 15 °C, Max. = 35 °C

**Control room** did not exceed following limits along the EMC testing:

Temperature	Min. = 15 °C, Max. = 35 °C
Relative humidity	Min. =30 %, Max. = 60 %
Shielding effectiveness	> 100 dB
Electrical insulation	> 10 kΩ
Ground system resistance	< 0.5 Ω

**Fully-anechoic chamber1** (9.8 meters×6.7 meters×6.7 meters) did not exceed following limits along the EMC testing:

Temperature	Min. = 15 °C, Max. = 35 °C
Relative humidity	Min. = 25 %, Max. = 75 %
Shielding effectiveness	> 100 dB
Electrical insulation	> 10 kΩ
Ground system resistance	< 0.5 Ω
VSWR	Between 0 and 6 dB, from 1GHz to 18GHz
Site Attenuation Deviation	Between -4 and 4 dB,30MHz to 1GHz

### 5.3 Measurement Uncertainty

Measurement Uncertainty of Conduction test

Measurement Items	Range	Confidence Level	Calculated Uncertainty
Emission Bandwidth	5150-5850MHz	95%	±1.9%
Maximum Conduct Output Power	5150-5850MHz	95%	± 1.18 dB
Power Spectral Density	5150-5850MHz	95%	±0.98 dB
Band Edge Measurements	5150-5850MHz	95%	±1.21dB

Unwanted Emissions Measurement	9kHz-40GHz	95%	9kHz-7GHz:±1.21dB 7GHz-40GHz: ±3.31dB
Frequency Stability	5150-5850MHz	95%	±1.9%

**Measurement Uncertainty of Radiation test**

Measurement Items	Uncertainty(dB)
Radiated Emission 30MHz-1000MHz	±5.10
Radiated Emission 1000MHz-18000MHz	±5.66
Radiated Emission 18000MHz-40000MHz	±5.22
AC Powerline Conducted Emission	±4.38

Note: This uncertainty represents an expanded uncertainty expressed at approximately the 95% confidence level using a coverage factor of  $k=2$ .



## 6. Measurement Results

### 6.1 Duty cycle

#### 6.1.1 Measurement Limit and Method

Standard	Limit (dBm)
FCC CRF Part 15.407(a)	NA
RSS-247 6.2.4.2	N/A

#### 6.1.2 Test Procedure

The measurement method is made according to KDB 789033 B

Measurements of duty cycle and transmission duration shall be performed using one of the following techniques:

- a) A diode detector and an oscilloscope that together have sufficiently short response time to permit accurate measurements of the on and off times of the transmitted signal.
- b) The zero-span mode on a spectrum analyzer or EMI receiver, if the response time and spacing between bins on the sweep are sufficient to permit accurate measurements of the on and off times of the transmitted signal. Set the center frequency of the instrument to the center frequency of the transmission, Set  $RBW > EBW$  if possible; otherwise, set  $RBW$  to the largest available value. Set  $VBW > RBW$ . Set detector = peak or average. The zero-span measurement method shall not be used unless both  $RBW$  and  $VBW$  are  $> 50/T$ , where  $T$  is defined in II.B.1.a), and the number of sweep points across duration  $T$  exceeds 100. (For example, if  $VBW$  and/or  $RBW$  are limited to 3 MHz, then the zero-span method of measuring duty cycle shall not be used if  $T < 16.7$  microseconds.)

#### 6.1.3 Measurement Results

Test Mode	Antenna	Frequency [MHz]	Transmission Duration [ms]	Transmission Period [ms]	Duty Cycle [%]
11A	Ant1	5745	2.07	2.10	98.57
11A	Ant1	5785	2.07	2.10	98.57
11A	Ant1	5825	2.06	2.10	98.10
11N20SISO	Ant1	5745	1.92	1.96	97.96
11N20SISO	Ant1	5785	1.92	1.96	97.96
11N20SISO	Ant1	5825	1.92	1.96	97.96
11N40SISO	Ant1	5755	0.95	0.99	95.96
11N40SISO	Ant1	5795	0.95	0.99	95.96
11AC20SISO	Ant1	5745	1.93	1.97	97.97
11AC20SISO	Ant1	5785	1.93	1.96	98.47
11AC20SISO	Ant1	5825	1.93	1.97	97.97
11AC40SISO	Ant1	5755	0.96	0.99	96.97
11AC40SISO	Ant1	5795	0.96	0.99	96.97
11AC80SISO	Ant1	5775	0.47	0.50	94.00

Test Graphs

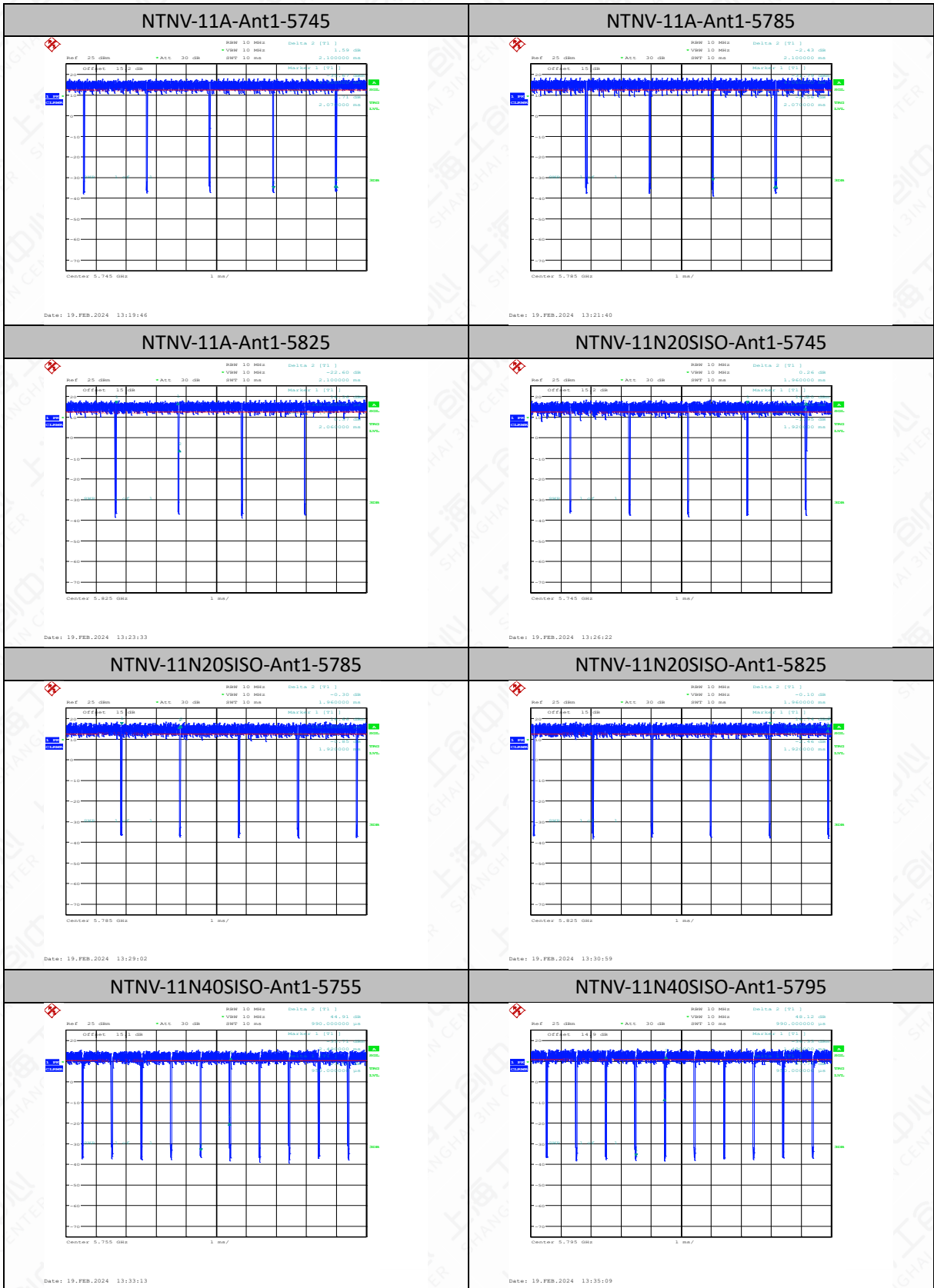



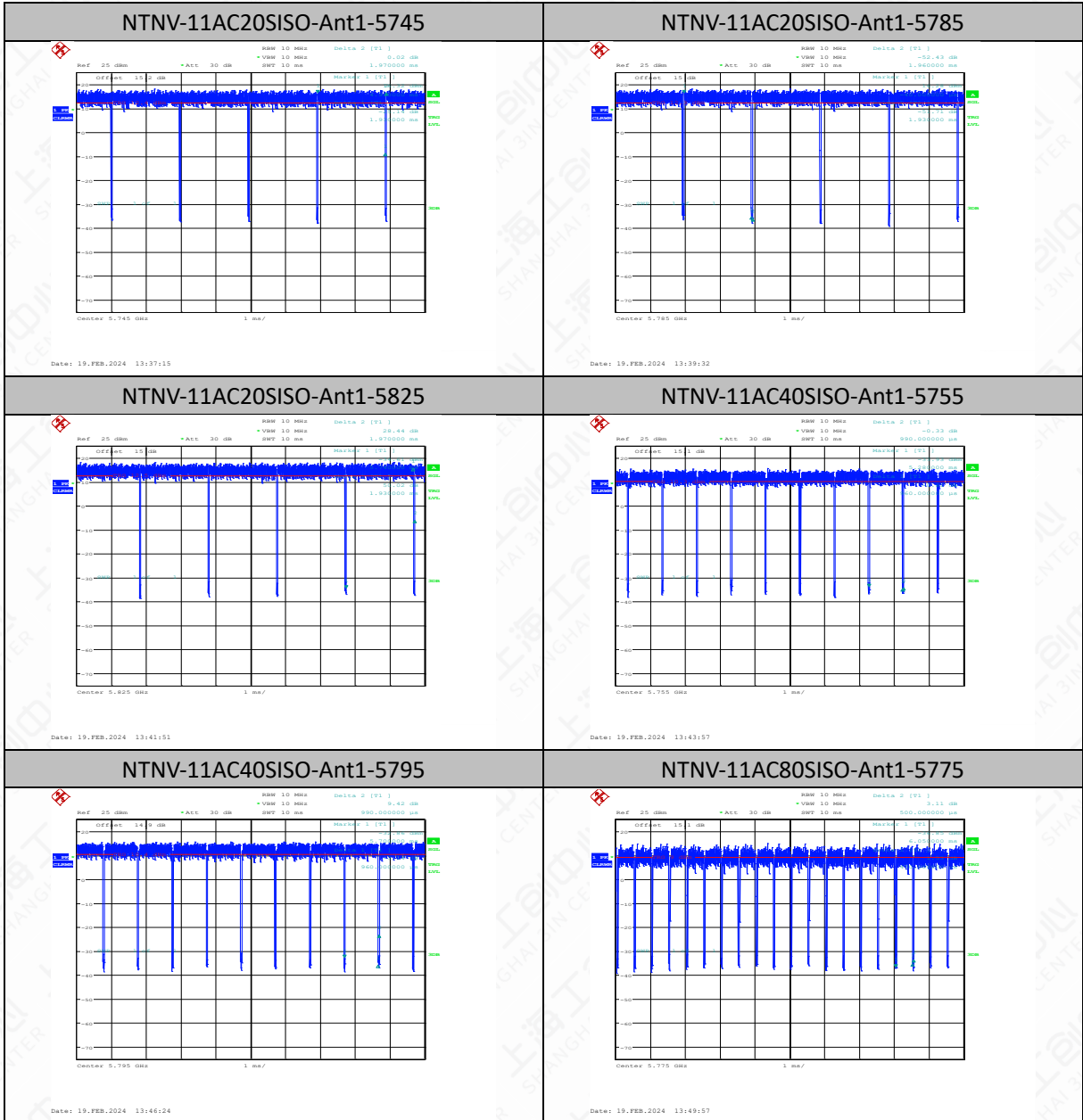

## 6.2 Maximum Average Output Power

### 6.2.1 Measurement Limit and Method

Standard	Limit (dBm)
FCC CRF Part 15.407(a)	< 30
RSS-247 6.2.4.2	< 30

### 6.2.2 Test Procedure

The measurement method SA-2 is made according to KDB 789033 E

Method SA-2 (trace averaging across on and off times of the EUT transmissions, followed by duty cycle correction).

1. Measure the duty cycle,  $x$ , of the transmitter output signal as described in II.B.
2. Set span to encompass the EBW (or, alternatively, the entire 99% occupied bandwidth) of the signal.
3. Set RBW = 1 MHz. (iv) Set VBW  $\geq$  3 MHz.
4. Number of points in sweep  $\geq 2 \times \text{span} / \text{RBW}$ . (This ensures that bin-to-bin spacing is  $\leq \text{RBW}/2$ , so that narrowband signals are not lost between frequency bins.)
5. Sweep time = auto.
6. Detector = power averaging (rms), if available. Otherwise, use sample detector mode.
7. Do not use sweep triggering. Allow the sweep to “free run.”
8. Trace average at least 100 traces in power averaging (rms) mode; however, the number of traces to be averaged shall be increased above 100 as needed to ensure that the average accurately represents the true average over the on and off periods of the transmitter.
9. Compute power by integrating the spectrum across the EBW (or, alternatively, the entire 99% occupied bandwidth) of the signal using the instrument’s band power measurement function with band limits set equal to the EBW (or occupied bandwidth) band edges. If the instrument does not have a band power function, sum the spectrum levels (in power units) at 1 MHz intervals extending across the EBW (or, alternatively, the entire 99% occupied bandwidth) of the signal.
10. Add  $10 \log (1/x)$ , where  $x$  is the duty cycle, to the measured power to compute the average power during the actual transmission times (because the measurement represents an average over both the on and off times of the transmission). For example, add  $10 \log (1/0.25) = 6 \text{ dB}$  if the duty cycle is 25%

### 6.2.3 Test setup

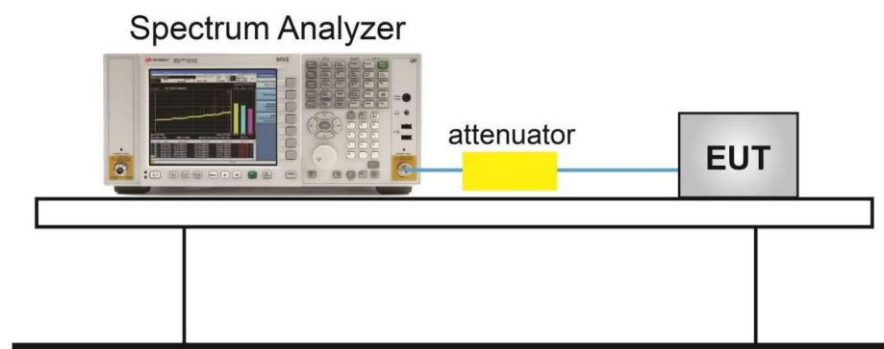



## 6.2.4 Measurement Results

Test Mode	Frequency [MHz]	Set Power	Duty Cycle [%]	DC Factor [dBm]	Result [dBm]	Limit [dBm]	Gain [dBi]	EIRP [dBm]	Verdict
11A	5745	18	98.57	0.06	13.25	≤30.00	2.80	16.05	PASS
11A	5785	18	98.57	0.06	13.56	≤30.00	2.80	16.36	PASS
11A	5825	18	98.10	0.08	13.51	≤30.00	2.80	16.31	PASS
11N20SISO	5745	18	97.96	0.09	13.17	≤30.00	2.80	15.97	PASS
11N20SISO	5785	18	97.96	0.09	13.38	≤30.00	2.80	16.18	PASS
11N20SISO	5825	15.5	97.96	0.09	8.99	≤30.00	2.80	11.79	PASS
11N40SISO	5755	18	95.96	0.18	13.81	≤30.00	2.80	16.61	PASS
11N40SISO	5795	18	95.96	0.18	14.04	≤30.00	2.80	16.84	PASS
11AC20SISO	5745	18	97.97	0.09	13.18	≤30.00	2.80	15.98	PASS
11AC20SISO	5785	18	98.47	0.07	13.37	≤30.00	2.80	16.17	PASS
11AC20SISO	5825	18	97.97	0.09	13.36	≤30.00	2.80	16.16	PASS
11AC40SISO	5755	18	96.97	0.13	13.70	≤30.00	2.80	16.50	PASS
11AC40SISO	5795	18	96.97	0.13	14.02	≤30.00	2.80	16.82	PASS
11AC80SISO	5775	17	94.00	0.27	11.33	≤30.00	2.80	14.13	PASS

## Note:

- 1.The Duty Cycle Factor is compensated in the graph.
2. In the graph, the Center frequency = (Low frequency of 26dB OBW + High frequency of 26dB OBW) /2.
- 3.The 11a data rate 6Mbps is selected as worse condition, 11n/11ac data rate MCS0 is selected as worse condition, and the following cases are performed with this condition.

## Test Graphs channel power

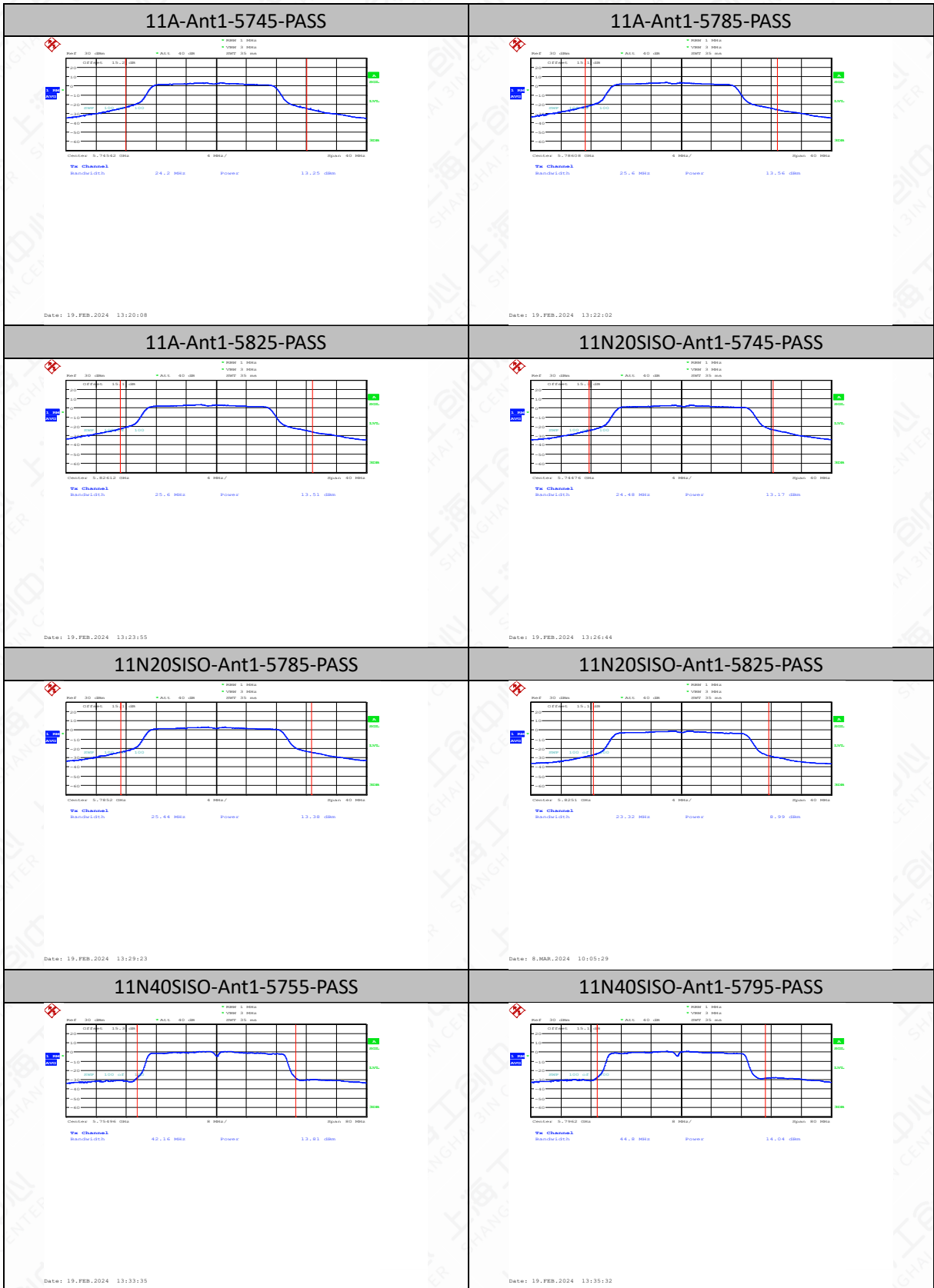



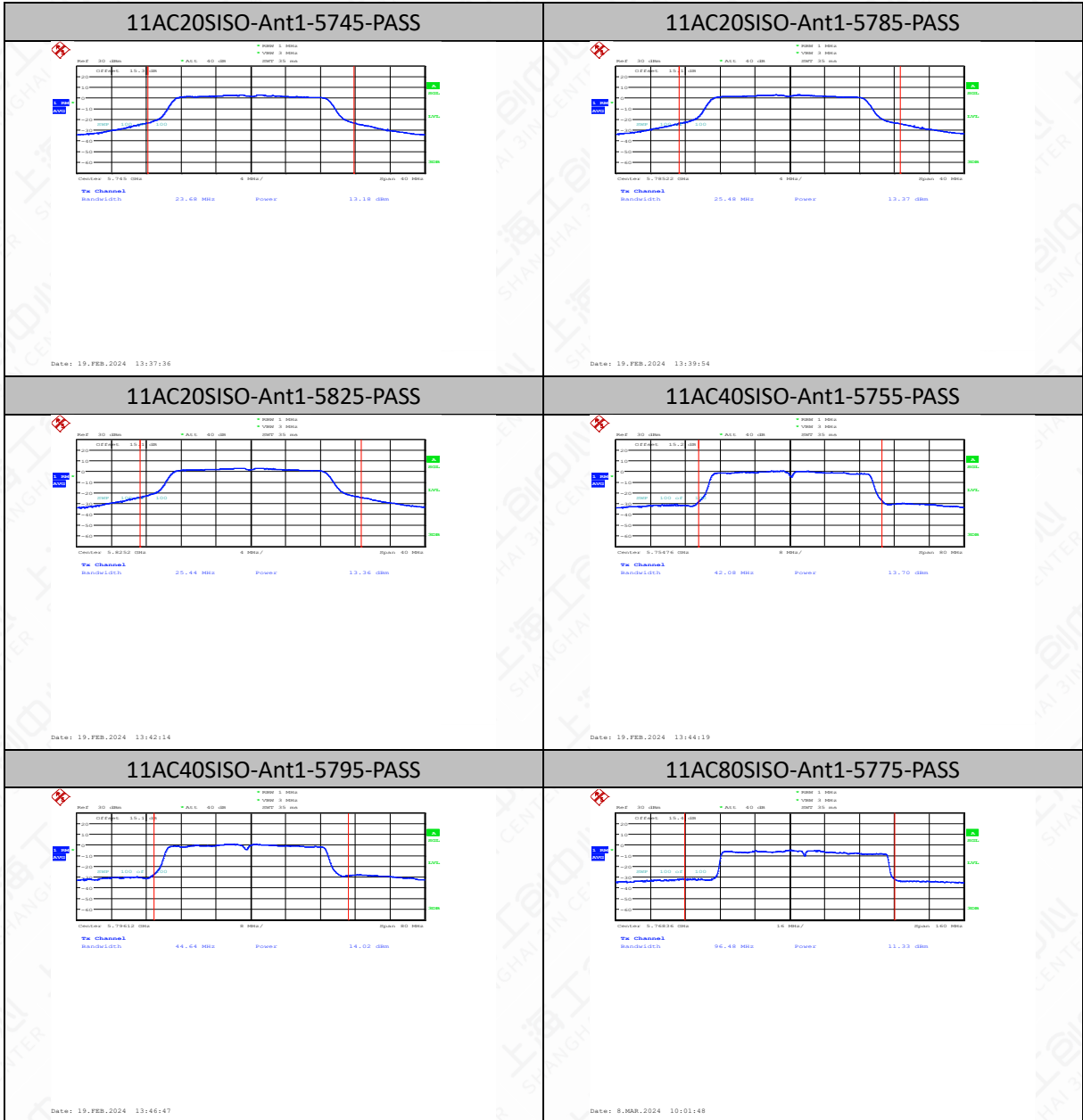

### 6.3 Peak Power Spectral Density

#### 6.2.1 Measurement Limit

Standard	Limit
FCC 47 CFR Part 15.407(a)	< 30 dBm/500kHz
RSS-247 6.2.4.2	< 30dBm/500kHz

#### 6.2.2 Test Procedure

The measurement method is made according to KDB 789033 F

1. Create an average power spectrum for the EUT operating mode being tested by following the instructions in II.E.2. for measuring maximum conducted output power using a spectrum analyzer or EMI receiver: select the appropriate test method (SA-1, SA-2, SA-3, or alternatives to each) and apply it up to, but not including, the step labeled, "Compute power...." (This procedure is required even if the maximum conducted output power measurement was performed using a power meter, method PM.)
2. Use the peak search function on the instrument to find the peak of the spectrum and record its value.
3. Make the following adjustments to the peak value of the spectrum, if applicable:
  - a) If Method SA-2 or SA-2 Alternative was used, add  $10 \log(1/x)$ , where  $x$  is the duty cycle, to the peak of the spectrum.
  - b) If Method SA-3 Alternative was used and the linear mode was used in step II.E.2.g)(viii), add 1 dB to the final result to compensate for the difference between linear averaging and power averaging.
4. The result is the Maximum PSD over 1 MHz reference bandwidth.
5. For devices operating in the bands 5.15-5.25 GHz, 5.25-5.35 GHz, and 5.47-5.725 GHz, the above procedures make use of 1 MHz RBW to satisfy directly the 1 MHz reference bandwidth specified in Section 15.407(a)(5). For devices operating in the band 5.725-5.85 GHz, the rules specify a measurement bandwidth of 500 kHz. Many spectrum analyzers do not have 500 kHz RBW, thus a narrower RBW may need to be used. The rules permit the use of a RBWs less than 1 MHz, or 500 kHz, "provided that the measured power is integrated over the full reference bandwidth" to show the total power over the specified measurement bandwidth (i.e., 1 MHz, or 500 kHz). If measurements are performed using a reduced resolution bandwidth (< 1 MHz, or < 500 kHz) and integrated over 1 MHz, or 500 kHz bandwidth, the following adjustments to the procedures apply:
  - a) Set  $RBW \geq 1/T$ , where  $T$  is defined in II.B.1.a).
  - b) Set  $VBW \geq 3 RBW$ .
  - c) If measurement bandwidth of Maximum PSD is specified in 500 kHz, add  $10 \log(500 \text{ kHz}/RBW)$  to the measured result, whereas RBW (<500 kHz) is the reduced resolution bandwidth of the spectrum analyzer set during measurement.
  - d) If measurement bandwidth of Maximum PSD is specified in 1 MHz, add  $10 \log(1\text{MHz}/RBW)$  to the measured result, whereas RBW (< 1 MHz) is the reduced resolution bandwidth of spectrum analyzer set during measurement.
  - e) Care must be taken to ensure that the measurements are performed during a period of continuous transmission or are corrected upward for duty cycle.

Note: As a practical matter, it is recommended to use reduced RBW of 100 kHz for steps 5.c) and 5.d) above, since RBW=100 KHZ is available on nearly all spectrum analyzers.



## 6.2.3 Test setup

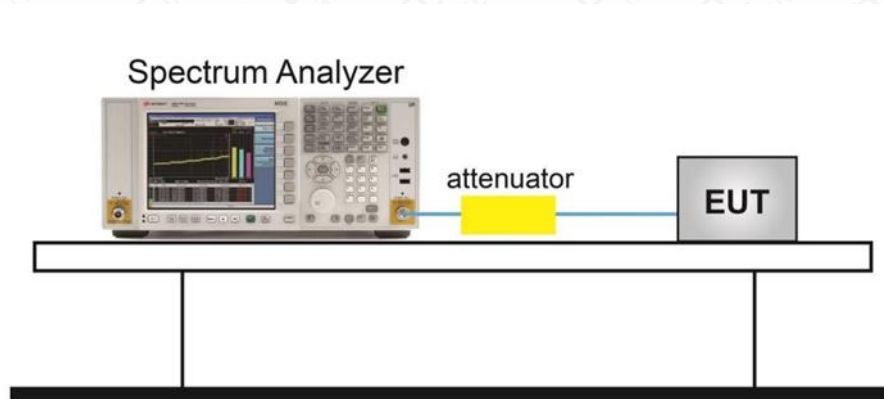

## 6.2.4 Measurement Results

TestMode	Antenna	Frequency[MHz]	Result [dBm/MHz]	Limit[dBm/MHz]	Verdict
11A	Ant1	5745	-0.26	≤30.00	PASS
11A	Ant1	5785	0.16	≤30.00	PASS
11A	Ant1	5825	0.20	≤30.00	PASS
11N20SISO	Ant1	5745	-0.68	≤30.00	PASS
11N20SISO	Ant1	5785	-0.37	≤30.00	PASS
11N20SISO	Ant1	5825	-4.56	≤30.00	PASS
11N40SISO	Ant1	5755	-2.99	≤30.00	PASS
11N40SISO	Ant1	5795	-2.66	≤30.00	PASS
11AC20SISO	Ant1	5745	-0.62	≤30.00	PASS
11AC20SISO	Ant1	5785	-0.41	≤30.00	PASS
11AC20SISO	Ant1	5825	-0.22	≤30.00	PASS
11AC40SISO	Ant1	5755	-3.07	≤30.00	PASS
11AC40SISO	Ant1	5795	-2.74	≤30.00	PASS
11AC80SISO	Ant1	5775	-8.49	≤30.00	PASS

Note: 1.The Result and Limit Unit is dBm/500 kHz in the band 5.725–5.85 GHz.

2.The Duty Cycle Factor is compensated in the graph.

Test graphs as below:

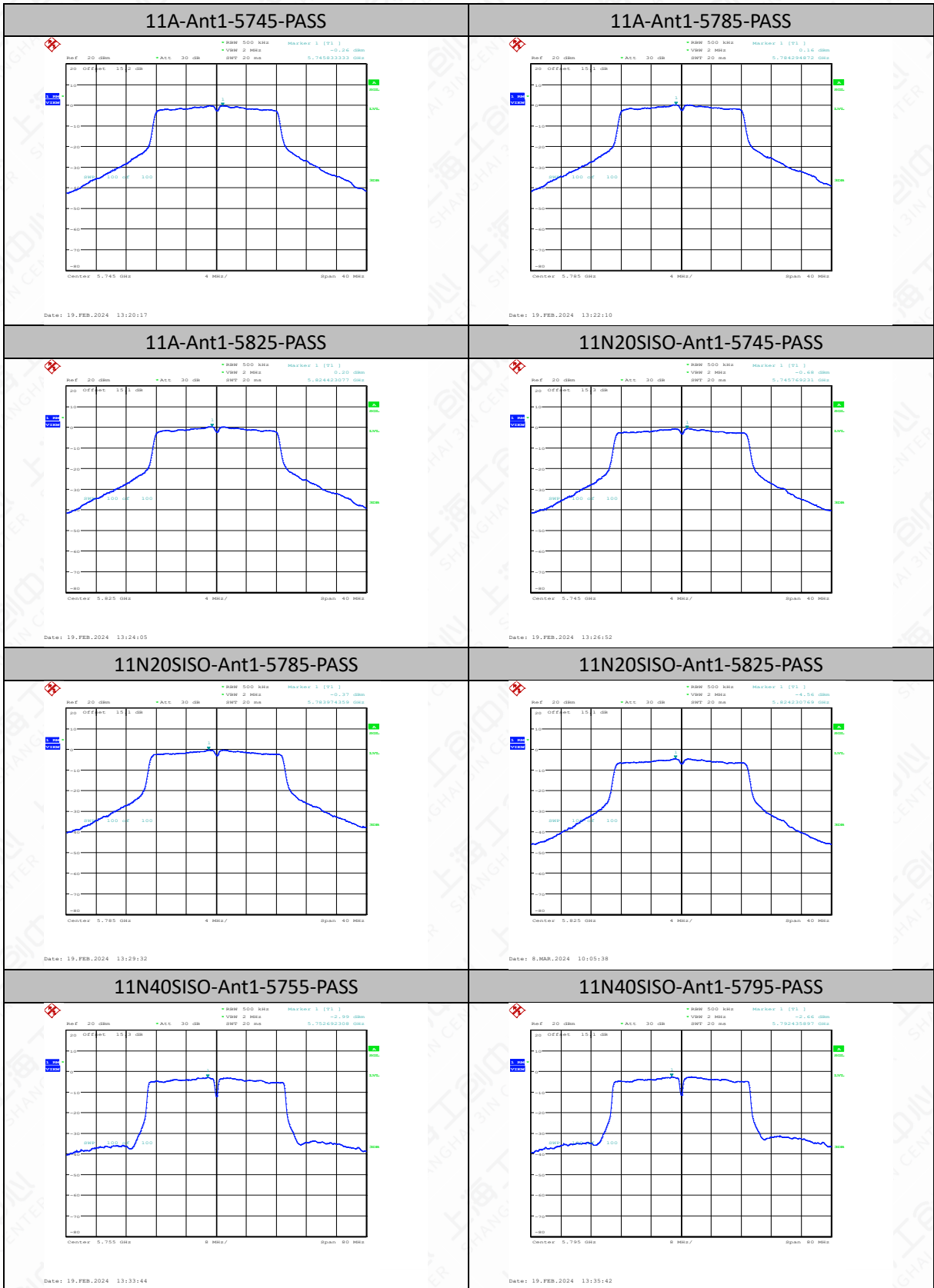



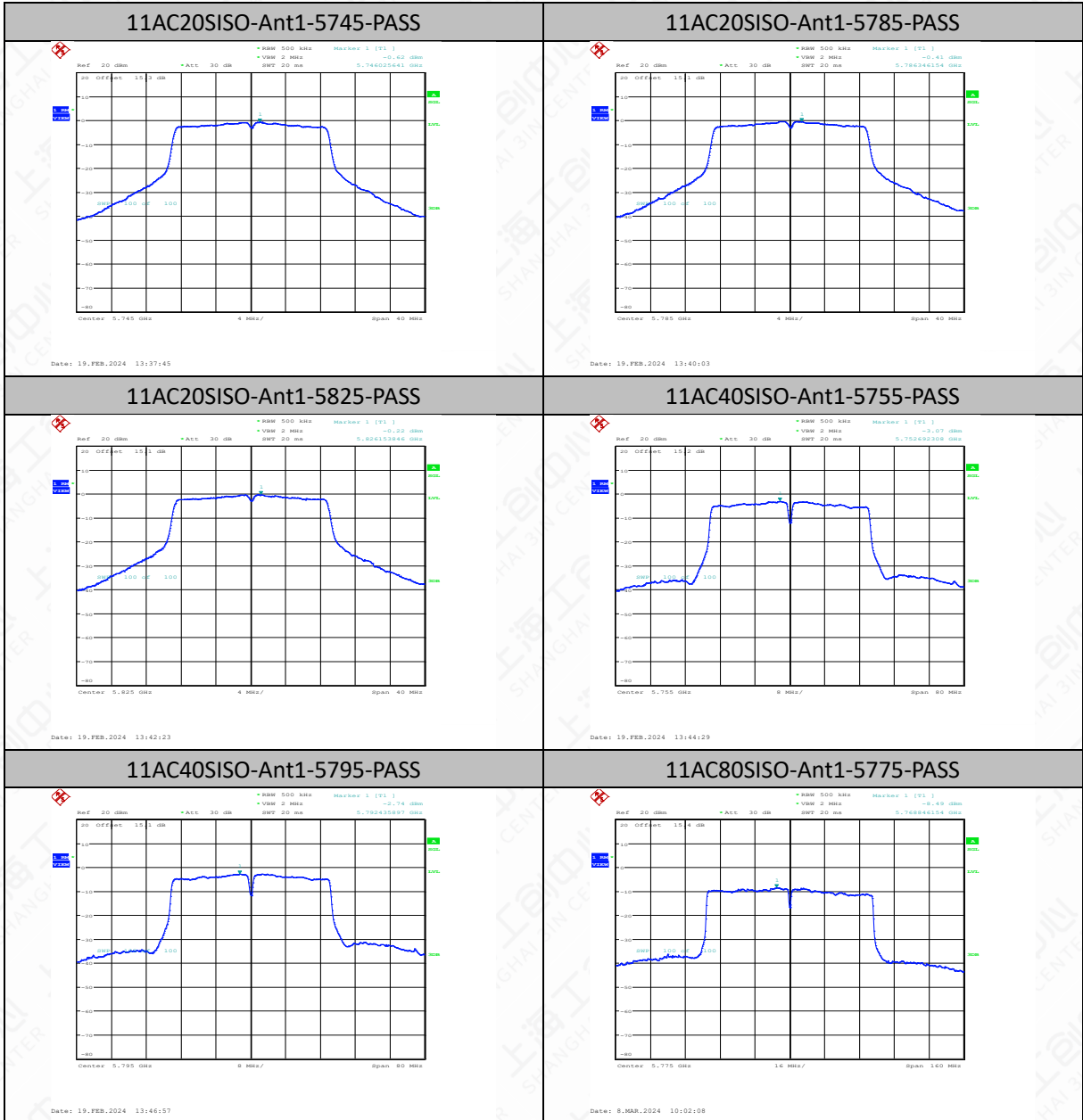

## 6.4 6dB & 26dB Occupied Bandwidth

### 6.4.1 Measurement Limit

Standard	Limit(KHz)
FCC 47 CFR Part 15.407(e)	≥500
RSS-247 6.2.4.2	≥500

### 6.4.2 Test Procedure

The measurement is made according to KDB 789033 C

Section 15.407(e) specifies the minimum 6 dB emission bandwidth of at least 500 kHz for the band 5.725-5.85GHz. The following procedure shall be used for measuring this bandwidth:

- a) Set RBW= 100 kHz.
- b) Set the video bandwidth (VBW)  $\geq 3 \times$  RBW.
- c) Detector = Peak.
- d) Trace mode = max hold.
- e) Sweep = auto couple.
- f) Allow the trace to stabilize.
- g) Measure the maximum width of the emission that is constrained by the frequencies associated with the two outermost amplitude points (upper and lower frequencies) that are attenuated by 6 dB and 26dB relative to the maximum level measured in the fundamental emission.

### 6.4.3 Test Setup

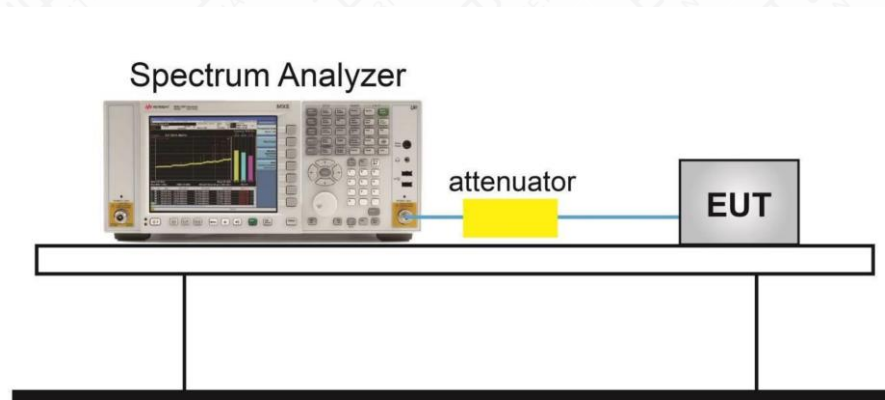



## 6.4.4 Measurement Result

**6dB Occupied Bandwidth Measurement Results:**

TestMode	Antenna	Frequency[MHz]	6db EBW [MHz]	FL[MHz]	FH[MHz]	Limit[MHz]	Verdict
11A	Ant1	5745	15.32	5737.28	5752.60	0.5	PASS
11A	Ant1	5785	15.28	5777.28	5792.56	0.5	PASS
11A	Ant1	5825	15.12	5817.52	5832.64	0.5	PASS
11N20SISO	Ant1	5745	16.52	5736.64	5753.16	0.5	PASS
11N20SISO	Ant1	5785	15.96	5776.64	5792.60	0.5	PASS
11N20SISO	Ant1	5825	15.96	5816.64	5832.60	0.5	PASS
11N40SISO	Ant1	5755	35.44	5737.16	5772.60	0.5	PASS
11N40SISO	Ant1	5795	35.28	5777.32	5812.60	0.5	PASS
11AC20SISO	Ant1	5745	16.56	5736.64	5753.20	0.5	PASS
11AC20SISO	Ant1	5785	16.52	5776.64	5793.16	0.5	PASS
11AC20SISO	Ant1	5825	15.96	5816.64	5832.60	0.5	PASS
11AC40SISO	Ant1	5755	35.12	5737.48	5772.60	0.5	PASS
11AC40SISO	Ant1	5795	35.44	5777.16	5812.60	0.5	PASS
11AC80SISO	Ant1	5775	75.04	5737.56	5812.60	0.5	PASS

Test graphs as below:

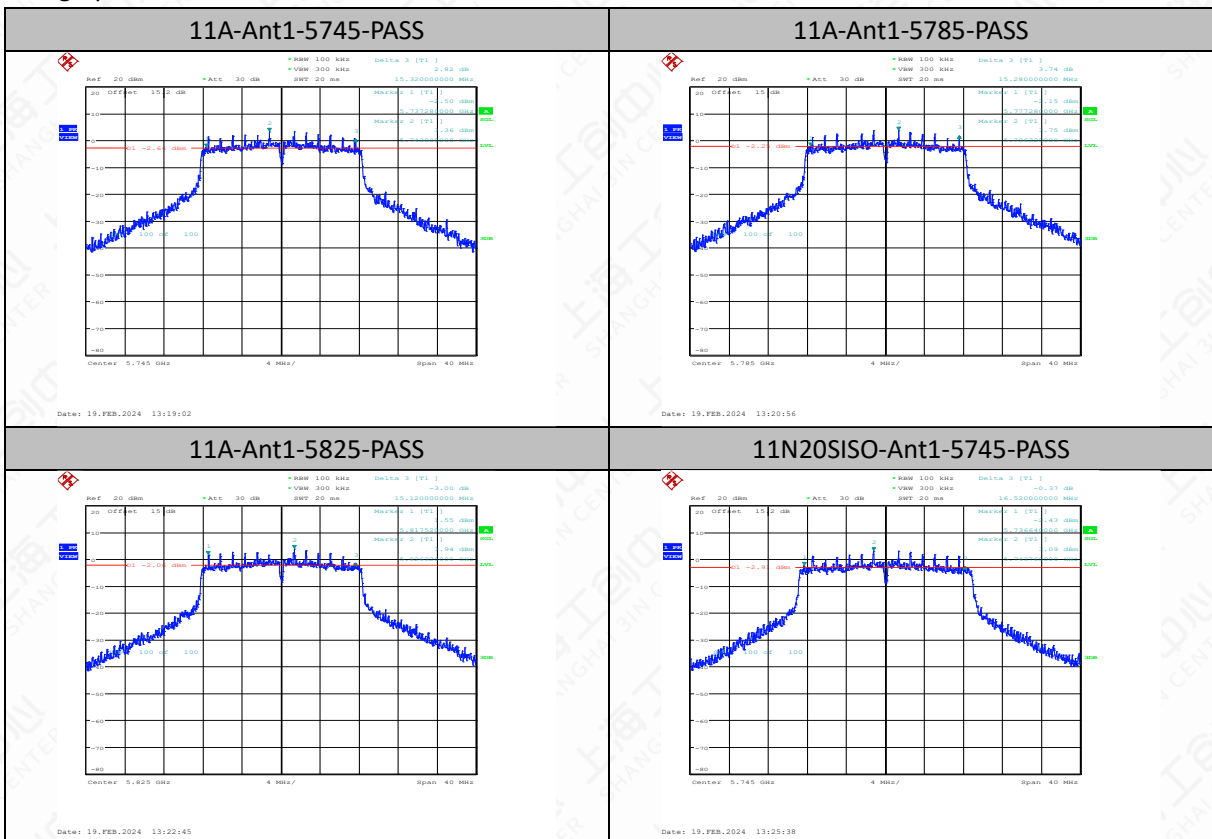

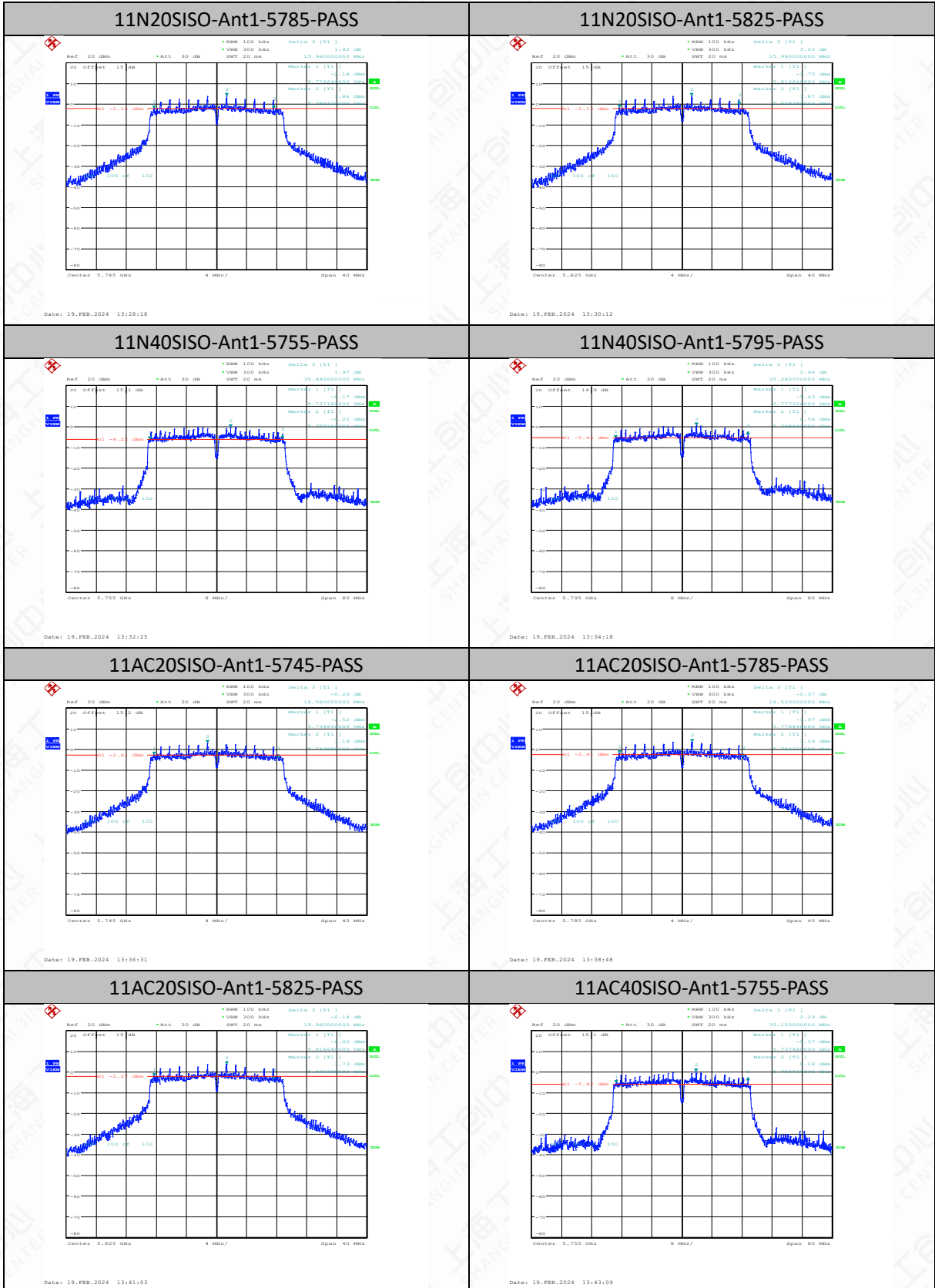



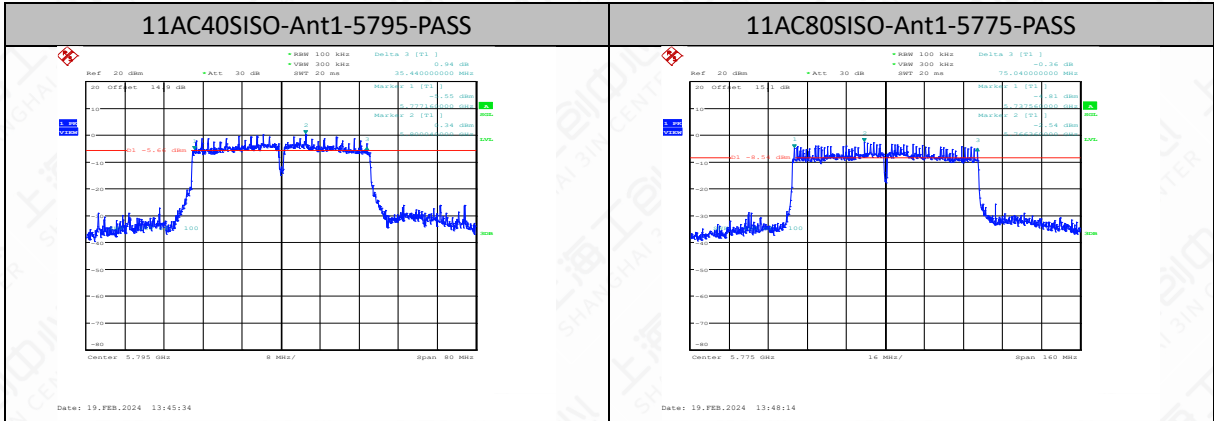

**26dB Occupied Bandwidth Measurement Results:**

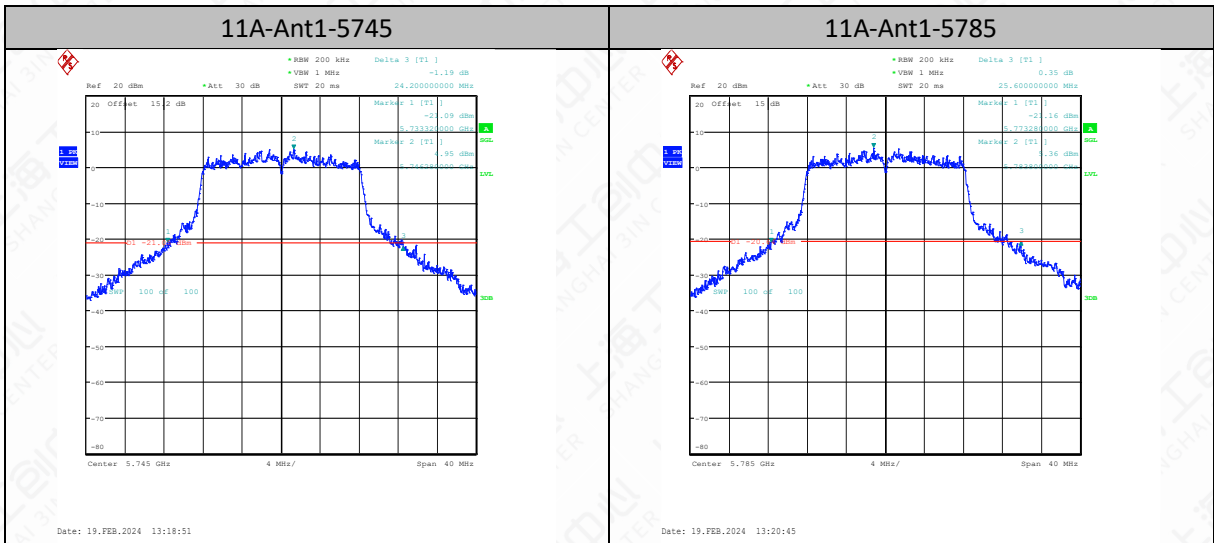
TestMode	Antenna	Frequency[MHz]	26db EBW [MHz]	FL[MHz]	FH[MHz]
11A	Ant1	5745	24.20	5733.32	5757.52
11A	Ant1	5785	25.60	5773.28	5798.88
11A	Ant1	5825	25.60	5813.32	5838.92
11N20SISO	Ant1	5745	24.48	5732.52	5757.00
11N20SISO	Ant1	5785	25.44	5772.48	5797.92
11N20SISO	Ant1	5825	23.32	5813.44	5836.76
11N40SISO	Ant1	5755	42.16	5733.88	5776.04
11N40SISO	Ant1	5795	44.80	5773.80	5818.60
11AC20SISO	Ant1	5745	23.68	5733.16	5756.84
11AC20SISO	Ant1	5785	25.48	5772.48	5797.96
11AC20SISO	Ant1	5825	25.44	5812.48	5837.92
11AC40SISO	Ant1	5755	42.08	5733.72	5775.80
11AC40SISO	Ant1	5795	44.64	5773.80	5818.44
11AC80SISO	Ant1	5775	96.48	5720.12	5816.60

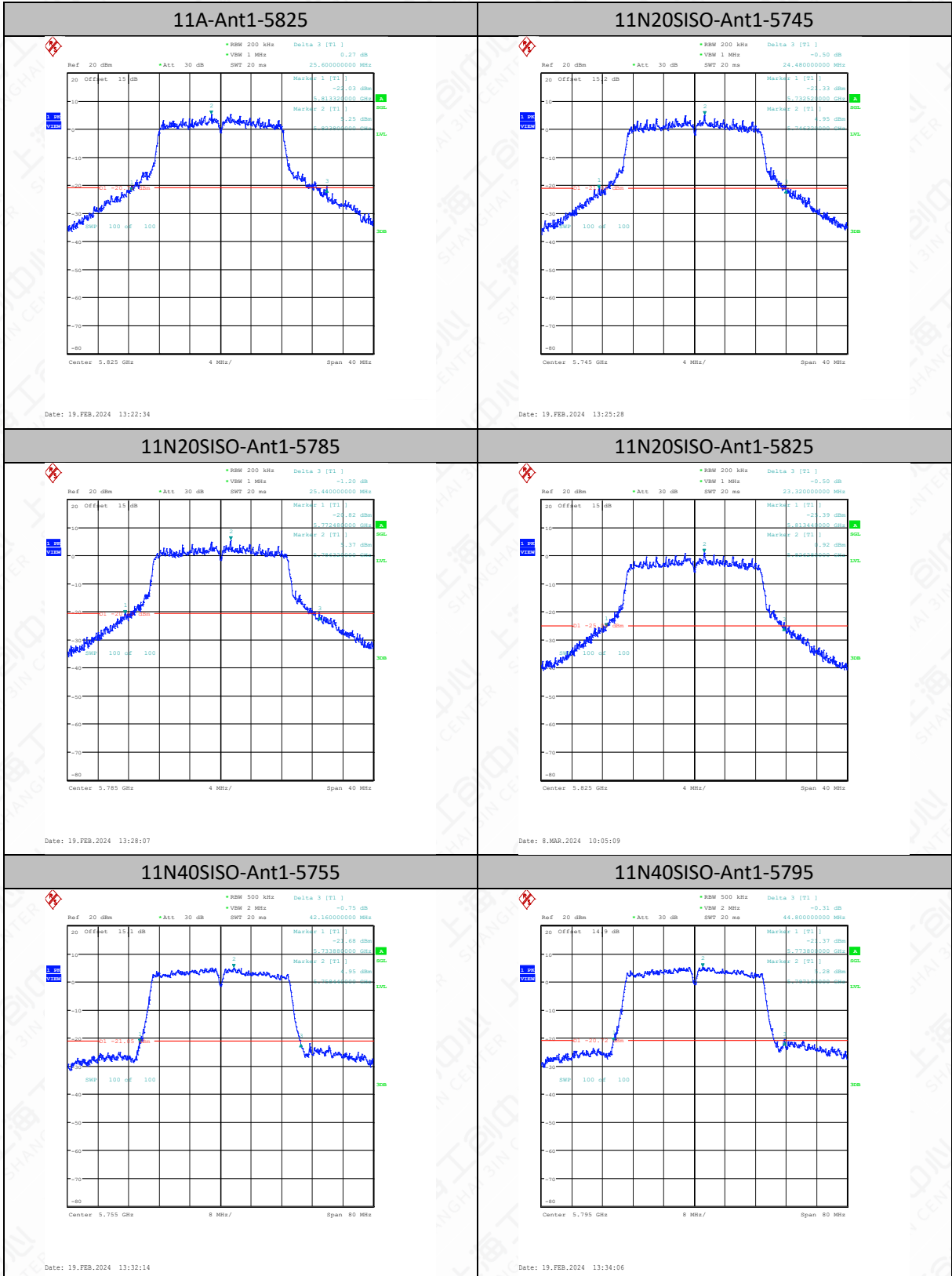
**Test Graphs**



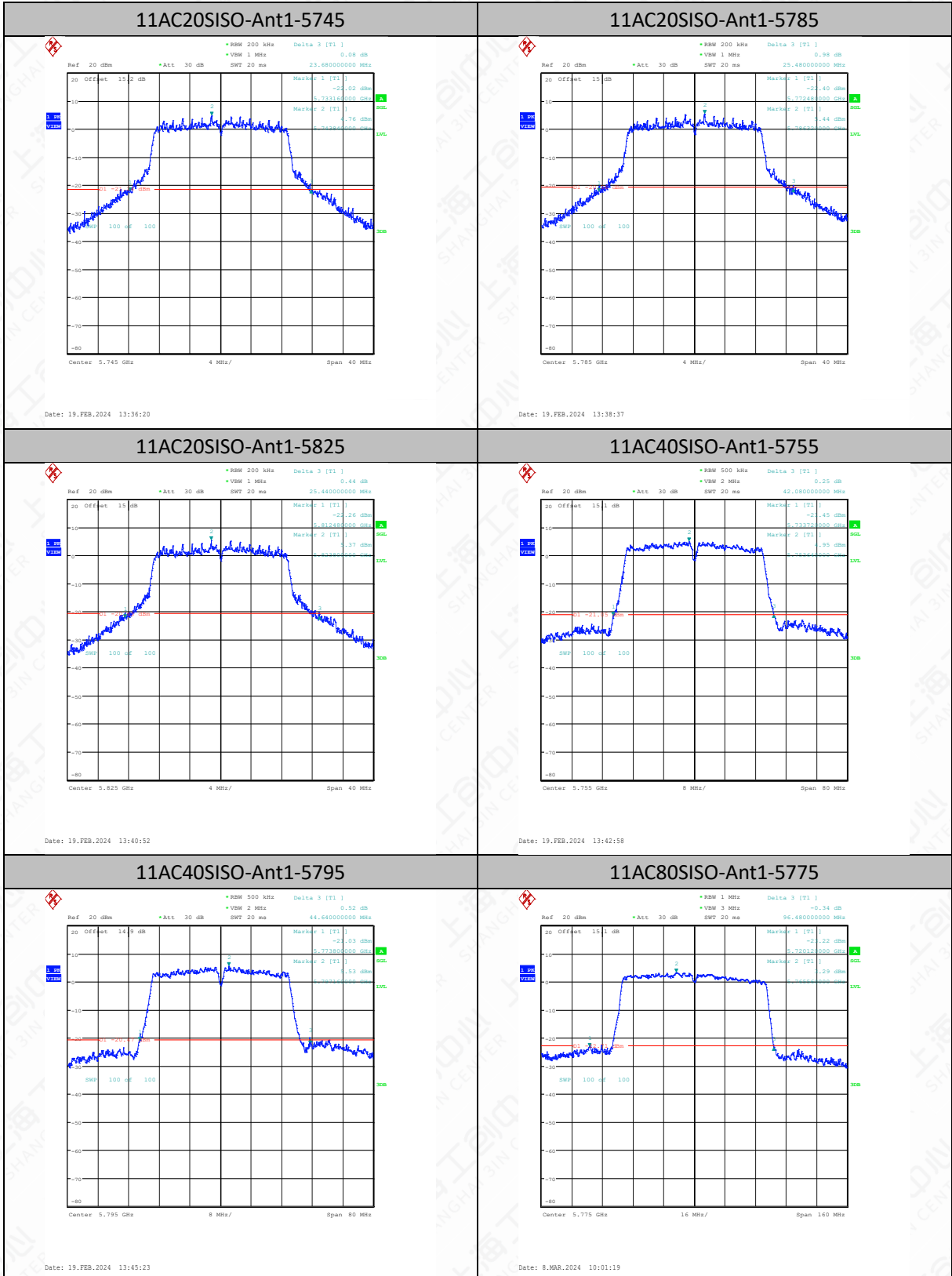



## 6.5 99% Occupied Bandwidth

### 6.5.1 Measurement Limit

Standard	Limit(KHz)
FCC 47 Part 15.247(e)	N/A
RSS-GEN 6.7	N/A

### 6.5.2 The measurement is made according to KDB 789033

The measurement method is made according to KDB 789033 D

1. Set center frequency to the nominal EUT channel center frequency.
2. Set span = 1.5 times to 5.0 times the OBW.
3. Set RBW = 1 % to 5 % of the OBW
4. Set VBW  $\geq 3 \cdot$  RBW
5. Video averaging is not permitted. Where practical, a sample detection and single sweep mode shall be used. Otherwise, peak detection and max hold mode (until the trace stabilizes) shall be used.
6. Use the 99 % power bandwidth function of the instrument (if available).
7. If the instrument does not have a 99 % power bandwidth function, the trace data points are recovered and directly summed in power units. The recovered amplitude data points, beginning at the lowest frequency, are placed in a running sum until 0.5 % of the total is reached; that frequency is recorded as the lower frequency. The process is repeated until 99.5 % of the total is reached; that frequency is recorded as the upper frequency. The 99% occupied bandwidth is the difference between these two frequencies.

### 6.5.3 Test Setup

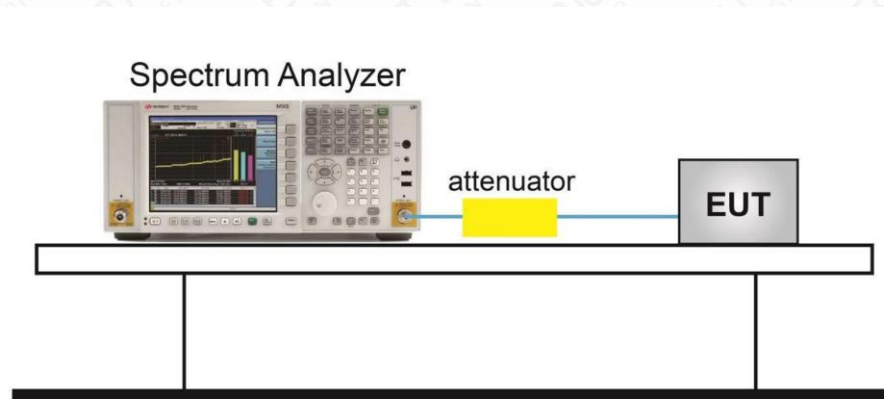

### 6.5.4 Measurement Result

TestMode	Antenna	Frequency[MHz]	OCB [MHz]	FL[MHz]	FH[MHz]	Limit[MHz]	Verdict
11A	Ant1	5745	17.44	5736.3200	5753.7600	---	---
11A	Ant1	5785	17.6	5776.2800	5793.8800	---	---
11A	Ant1	5825	17.56	5816.2800	5833.8400	---	---
11N20SISO	Ant1	5745	18.48	5735.8400	5754.3200	---	---
11N20SISO	Ant1	5785	18.64	5775.8000	5794.4400	---	---



11N20SISO	Ant1	5825	18.6	5815.8400	5834.4400	---	---
11N40SISO	Ant1	5755	36.8	5736.6800	5773.4800	---	---
11N40SISO	Ant1	5795	36.8	5776.7600	5813.5600	---	---
11AC20SISO	Ant1	5745	18.48	5735.8400	5754.3200	---	---
11AC20SISO	Ant1	5785	18.6	5775.8400	5794.4400	---	---
11AC20SISO	Ant1	5825	18.6	5815.8400	5834.4400	---	---
11AC40SISO	Ant1	5755	36.72	5736.6800	5773.4000	---	---
11AC40SISO	Ant1	5795	36.72	5776.7600	5813.4800	---	---
11AC80SISO	Ant1	5775	76.64	5736.7600	5813.4000	---	---

Test graphs as below

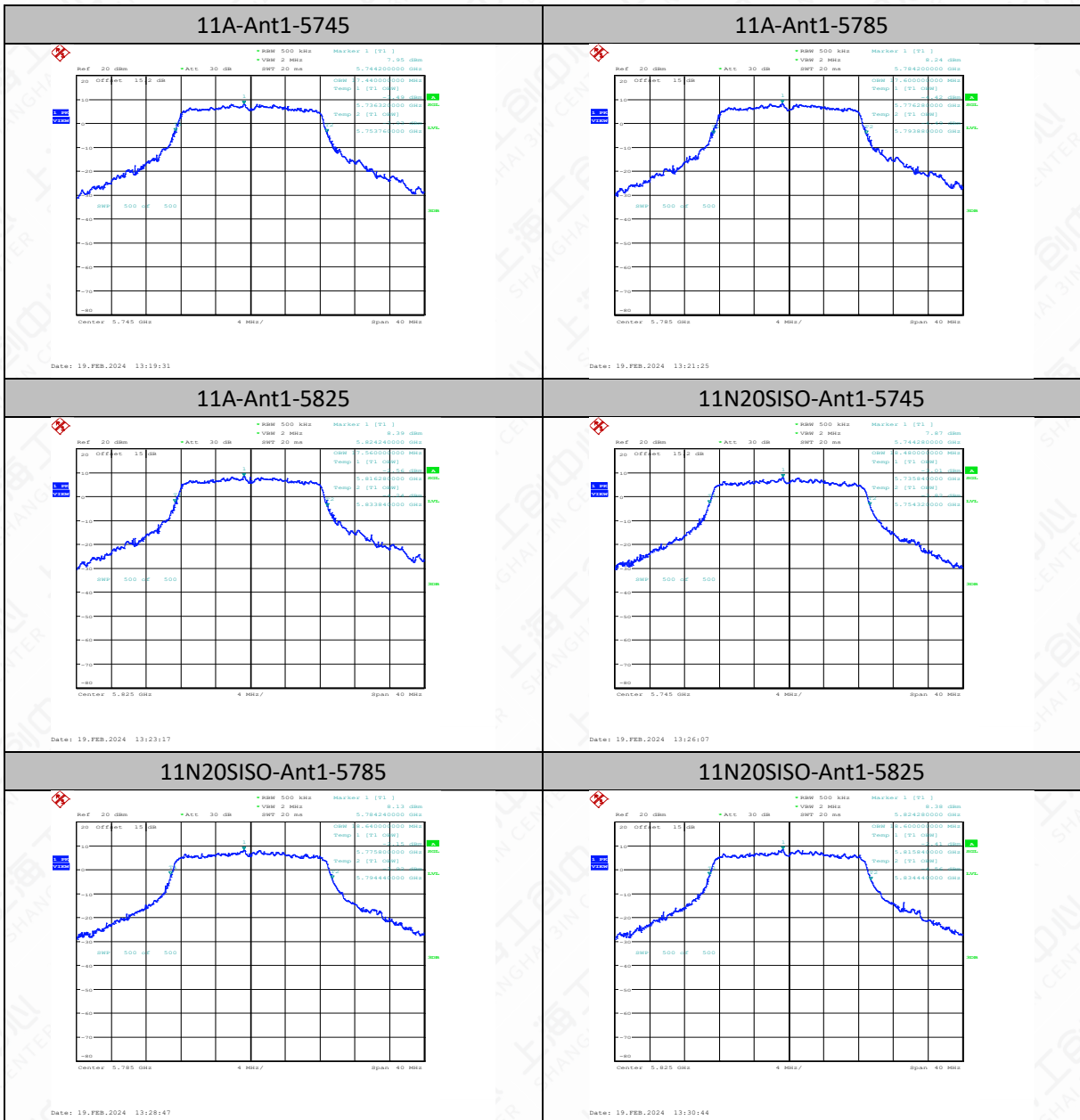

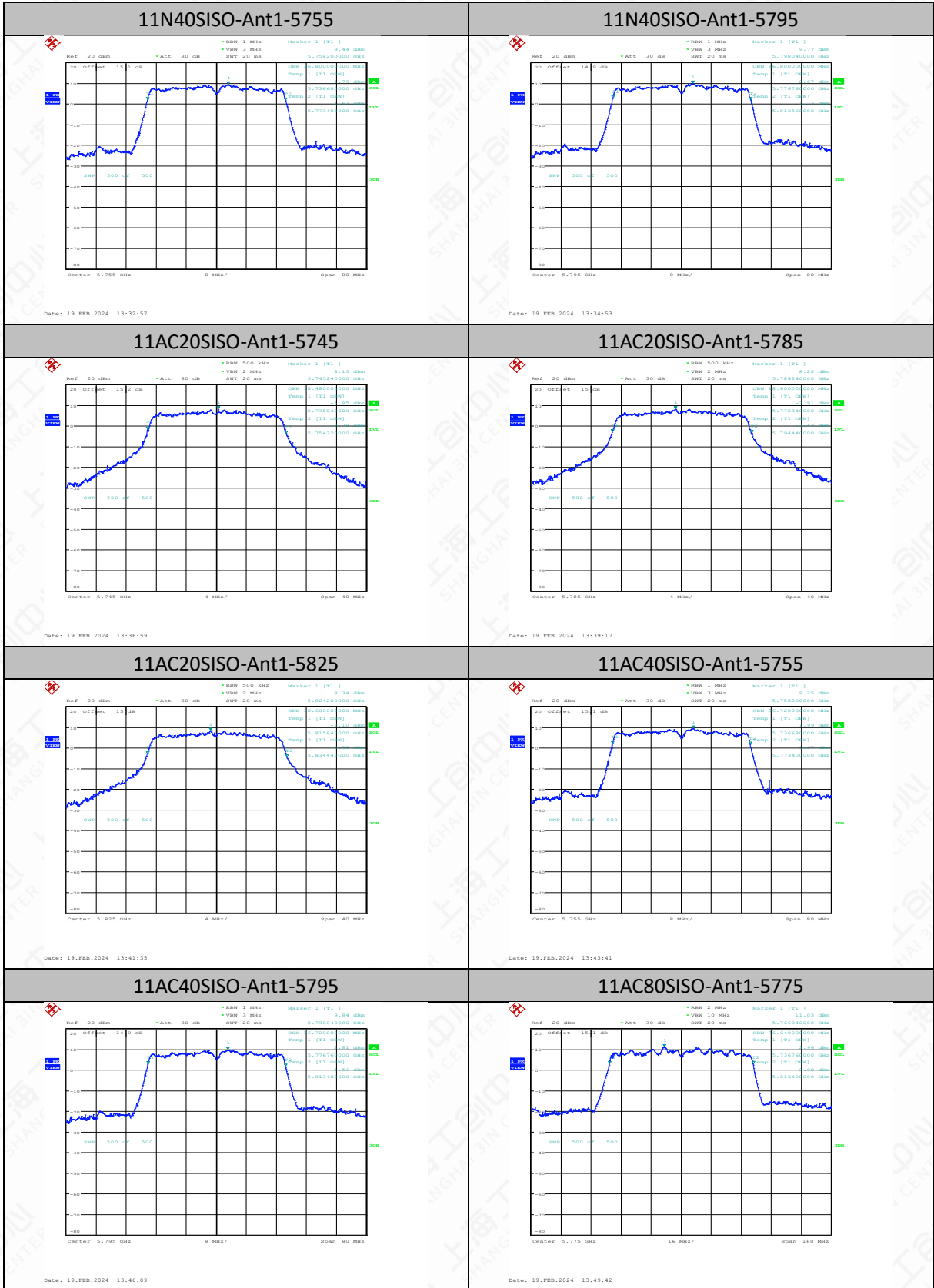

## 6.6 Frequency Stability

Manufacturers ensured the EUT meet the requirement of frequency stability, such that an emission is maintained within the band of operation under all conditions of normal operation as specified in the user's manual.(According to15.407(g) and RSS-Gen 8.11)



## 6.7 Transmitter Spurious Emission

### 6.7.1 Measurement Limit

The measurement is made according to ANSI C63.10.

#### Below 1G:

Frequency of emission (MHz)	Field strength(dBμV/m)	Measurement distance(m)
0.009-0.490	129-94	3
0.490-1.705	74-63	3
1.705-30	70	3
30-88	40.0	3
88-216	43.5	3
216-960	46.0	3
Above 960	54.0	3

Note: for frequency range below 960MHz, the limit in 15.209 is defined in 10m test distance. The limit used above is calculated from 10m to 3m

#### Above 1G, non-restricted band:

Standard	Limit
15.407(b)	EIRP < -27dBm/MHz
RSS-247 6.2	EIRP < -27dBm/MHz

#### Above 1G, Restricted band:

Standard	Limit	
15.407(b)	EIRP < -27dBm/MHz	
15.209	Peak	74dBμV/m
	Average	54dBμV/m
RSS-247 6.2	EIRP < -27dBm/MHz	
RSS-Gen 8.9	Peak	74dBμV/m
	Average	54dBμV/m

$$\text{EIRP[dBm]} = \text{E[dB}\mu\text{V/m]} + 20 \log(d[\text{m}]) - 104.7$$

$$\text{E[dB}\mu\text{V/m]} = \text{EIRP[dBm]} - 20 \log(d[\text{m}]) + 104.7$$

$$\text{E[dB}\mu\text{V/m]} = \text{EIRP[dBm]} + 95.2 = 68.2, \text{ for } d = 3\text{m}$$

### 6.7.2 Test procedures

The measurement is made according to KDB 789033

Set the spectrum analyzer in the following:

#### Procedure for Unwanted Emissions Measurements below 1000 MHz:

- a) Follow the requirements in II.G.3. "General Requirements for Unwanted Emissions"

Measurements.”

- b) Compliance shall be demonstrated using CISPR quasi-peak detection; however, peak detection is permitted as an alternative to quasi-peak detection.

Detector: Peak and Quasi-Peak

RBW=100kHz / VBW=300kHz / Sweep=AUTO

**Procedure for Unwanted Maximum Emissions Measurements above 1000 MHz:**

a) Follow the requirements in II.G.3, “General Requirements for Unwanted Emissions Measurements.”

b) Maximum emission levels are measured by setting the analyzer as follows:

- (i) RBW = 1 MHz.
- (ii) VBW  $\geq$  3 MHz.
- (iii) Detector = Peak.
- (iv) Sweep time = auto.
- (v) Trace mode = max hold.
- (vi) Allow sweeps to continue until the trace stabilizes. Note that if the transmission is not continuous, the time required for the trace to stabilize will increase by a factor of approximately  $1/x$ , where  $x$  is the duty cycle. For example, at 50% duty cycle, the measurement time will increase by a factor of two relative to measurement time for continuous transmission.

**Procedures for Average Unwanted Emissions Measurements above 1000 MHz:**

a) Follow the requirements in section II.G.3., “General Requirements for Unwanted Emissions Measurements.”

b) Average emission levels shall be measured using one of the following two methods.

c) Method AD (Average Detection): Primary method

(i) RBW = 1 MHz.

(ii) VBW  $\geq$  3 MHz.

(iii) Detector = power averaging (rms), if  $\text{span}/(\# \text{ of points in sweep}) \leq \text{RBW}/2$ . Satisfying this condition may require increasing the number of points in the sweep or reducing the span. If the condition is not satisfied, the detector mode shall be set to peak.

(iv) Averaging type = power averaging (rms)

As an alternative, the detector and averaging type may be set for linear voltage averaging. Some instruments require linear display mode in order to use linear voltage averaging. Log or dB averaging shall not be used.

(v) Sweep time = auto.

(vi) Perform a trace average of at least 100 traces if the transmission is continuous. If the transmission is not continuous, the number of traces shall be increased by a factor of  $1/x$ , where  $x$  is the duty cycle. For example, with 50% duty cycle, at least 200 traces shall be averaged. (If a specific emission is demonstrated to be continuous—i.e., 100% duty cycle—rather than turning on and off with the transmit cycle, at least 100 traces shall be averaged.)

(vii) If tests are performed with the EUT transmitting at a duty cycle less than 98%, a correction factor shall be added to the measurement results prior to comparing to the emission limit in order to compute the emission level that would have been measured had the test been performed at 100% duty cycle. The correction factor is computed as follows:

If power averaging (rms) mode was used in step (iv) above, the correction factor is  $10 \log (1/x)$ , where  $x$  is the duty cycle. For example, if the transmit duty cycle was 50%, then 3 dB must be added to the



measured emission levels.

If linear voltage averaging mode was used in step (iv) above, the correction factor is  $20 \log (1/x)$ , where  $x$  is the duty cycle. For example, if the transmit duty cycle was 50%, then 6 dB must be added to the measured emission levels.

If a specific emission is demonstrated to be continuous (100% duty cycle) rather than turning on and off with the transmit cycle, no duty cycle correction is required for that emission.

Portable, small, lightweight, or modular devices that may be handheld, worn on the body, or placed on a table during operation shall be positioned on a non-conducting platform, the top of which is 80 cm above the reference ground plane. The preferred area occupied by the EUT arrangement is 1 m by 1.5 m, For emissions testing at or below 1 GHz, the table height shall be 80 cm above the reference ground plane. For emission measurements above 1 GHz, the table height shall be 1.5 m. but it may be larger or smaller to accommodate various sized EUTs. For testing purposes, ceiling- and wall-mounted devices also shall be positioned on a tabletop (see also ANSI C63.10-2013 section 6.3.4 and 6.3.5). In making any tests involving handheld, body-worn, or ceiling-mounted equipment, it is essential to recognize that the measured levels may be dependent on the orientation (attitude) of the three orthogonal axes of the EUT. Thus, exploratory tests as specified in 8.3.1 shall be carried out for various axes orientations to determine the attitude having maximum or near-maximum emission level.

The EUT was placed on a non-conductive table. Below 18GHz , the measurement antenna was placed at a distance of 3 meters from the EUT. Above 18GHz , the measurement antenna was placed at a distance of 1 meter from the EUT. During the tests, the antenna height varied from 1m to 4m and the EUT azimuth were varied from  $0^\circ$  to  $360^\circ$  in order to identify the maximum level of emissions from the EUT. This maximization process was repeated with the EUT positioned in each of its three orthogonal orientations.

Remark:

1. Factor= Antenna Factor + Cable Loss (-Amplifier, is employed)
2. Measured level= Original Receiver Reading + Factor
3. Margin = Limit – Measured level
4. If the PK measured level is lower than AV limit, the AV test can be elided

### 6.7.3 Test Setup

#### Below 30MHz Test Setup

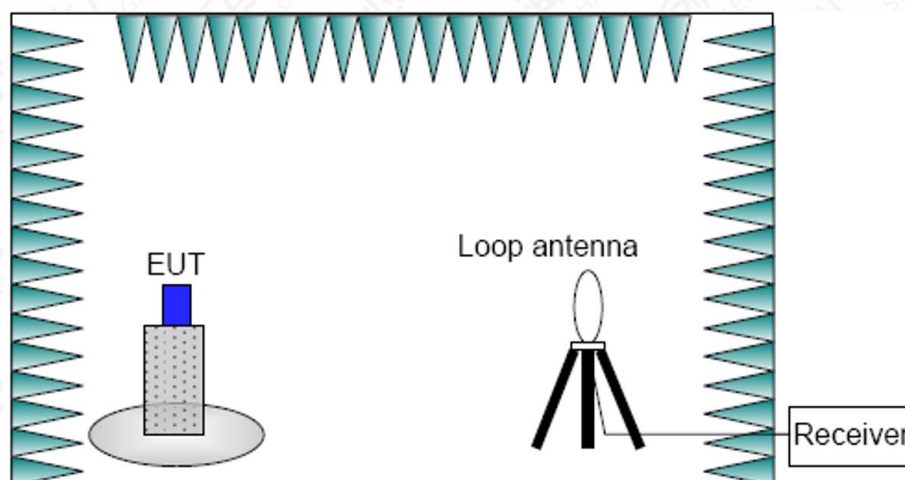



Below 1GHz Test Setup

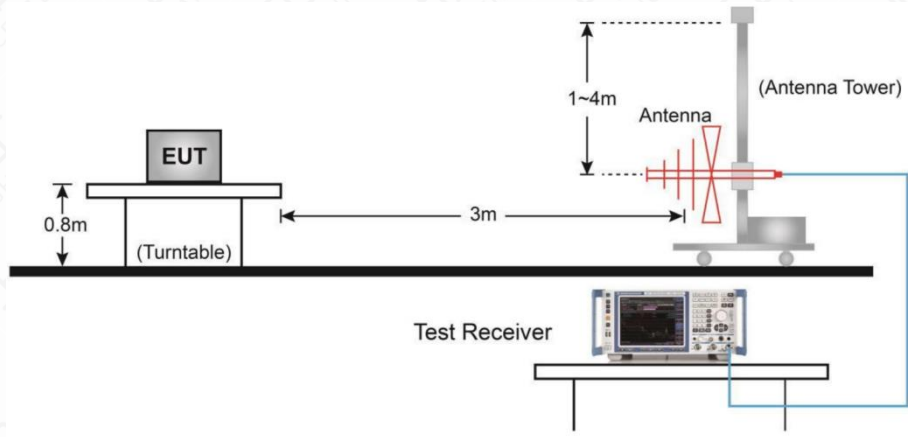

Above 1GHz Test Setup

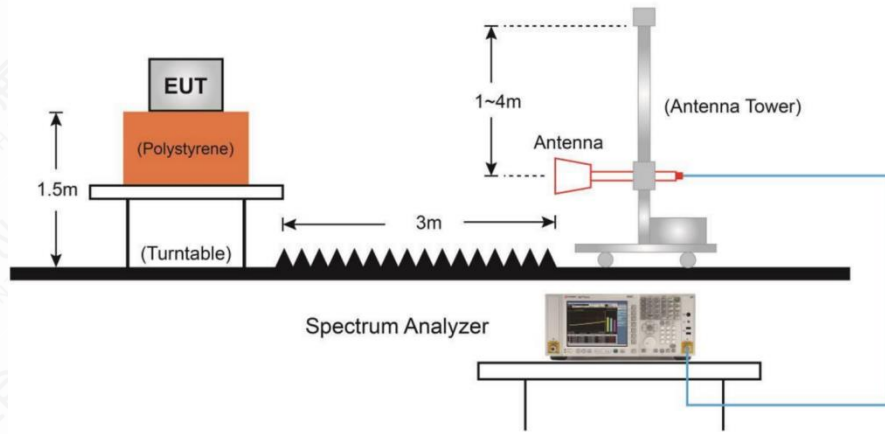

6.7.4 Measurement Results

Mode	Channel	Frequency Range	Conclusion
11A	149(5745MHz)	30 MHz ~1 GHz	P
		1 GHz ~ 8 GHz	P
		8 GHz ~ 18 GHz	P
		18 GHz ~ 26.5 GHz	P
		26.5 GHz~ 40 GHz	P
11N20 SISO	157(5785MHz)	30 MHz ~1 GHz	P
		1 GHz ~ 8 GHz	P
		8 GHz ~ 18 GHz	P
		18 GHz ~ 26.5 GHz	P
		26.5 GHz~ 40 GHz	P
11N40 SISO	159(5795MHz)	30 MHz ~1 GHz	P

		1 GHz ~ 8 GHz	P
		8 GHz ~ 18 GHz	P
		18 GHz ~ 26.5 GHz	P
		26.5 GHz~ 40 GHz	P
11AC20 SISO	165(5825MHz)	30 MHz ~1 GHz	P
		1 GHz ~ 8 GHz	P
		8 GHz ~ 18 GHz	P
		18 GHz ~ 26.5 GHz	P
		26.5 GHz~ 40 GHz	P
11AC40 SISO	151(5755MHz)	30 MHz ~1 GHz	P
		1 GHz ~ 8 GHz	P
		8 GHz ~ 18 GHz	P
		18 GHz ~ 26.5 GHz	P
		26.5 GHz~ 40 GHz	P
11AC80 SISO	155(5775MHz)	30 MHz ~1 GHz	P
		1 GHz ~ 8 GHz	P
		8 GHz ~ 18 GHz	P
		18 GHz ~ 26.5 GHz	P
		26.5 GHz~ 40 GHz	P

Test graphs as below

Mainly Supply(S02)

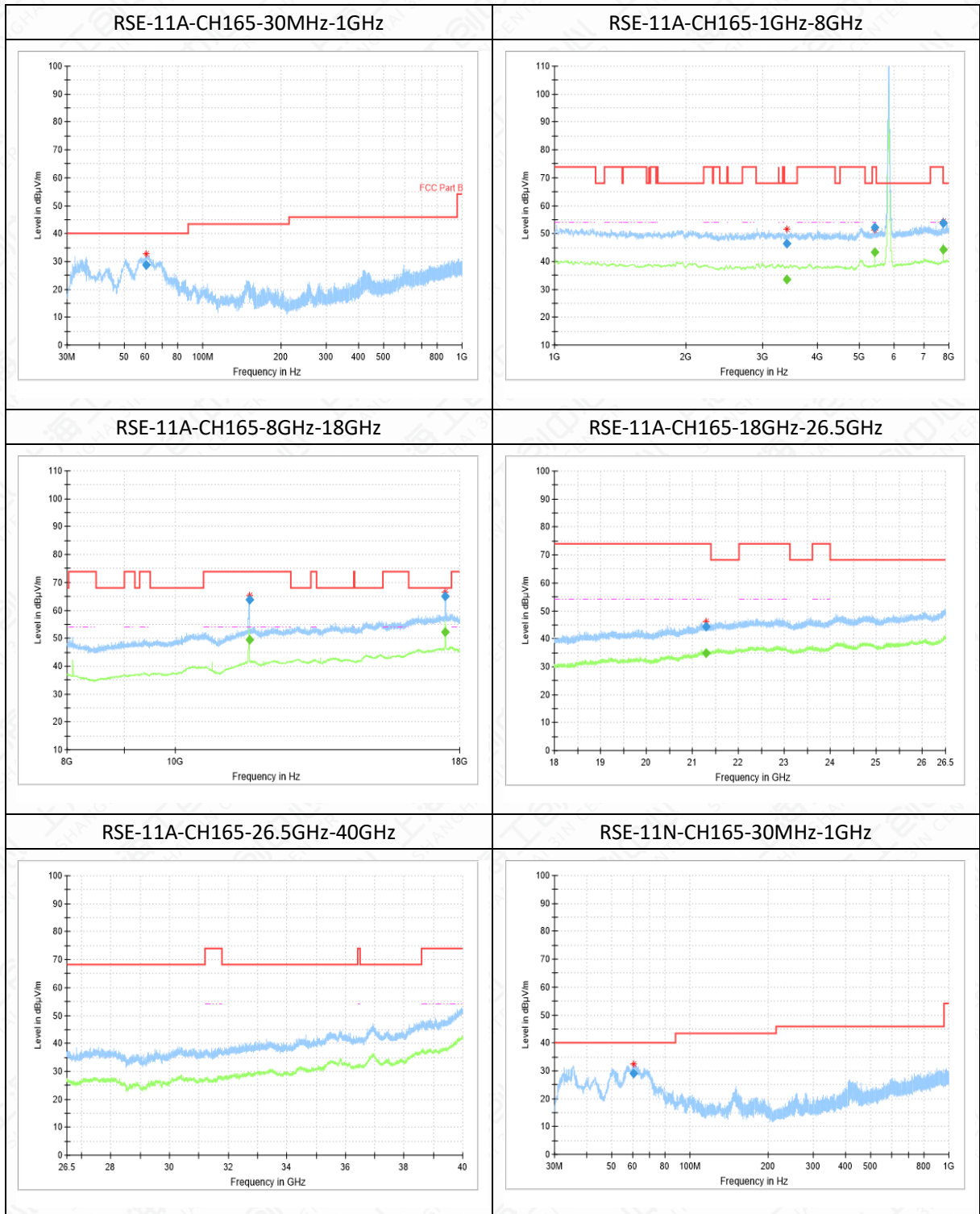



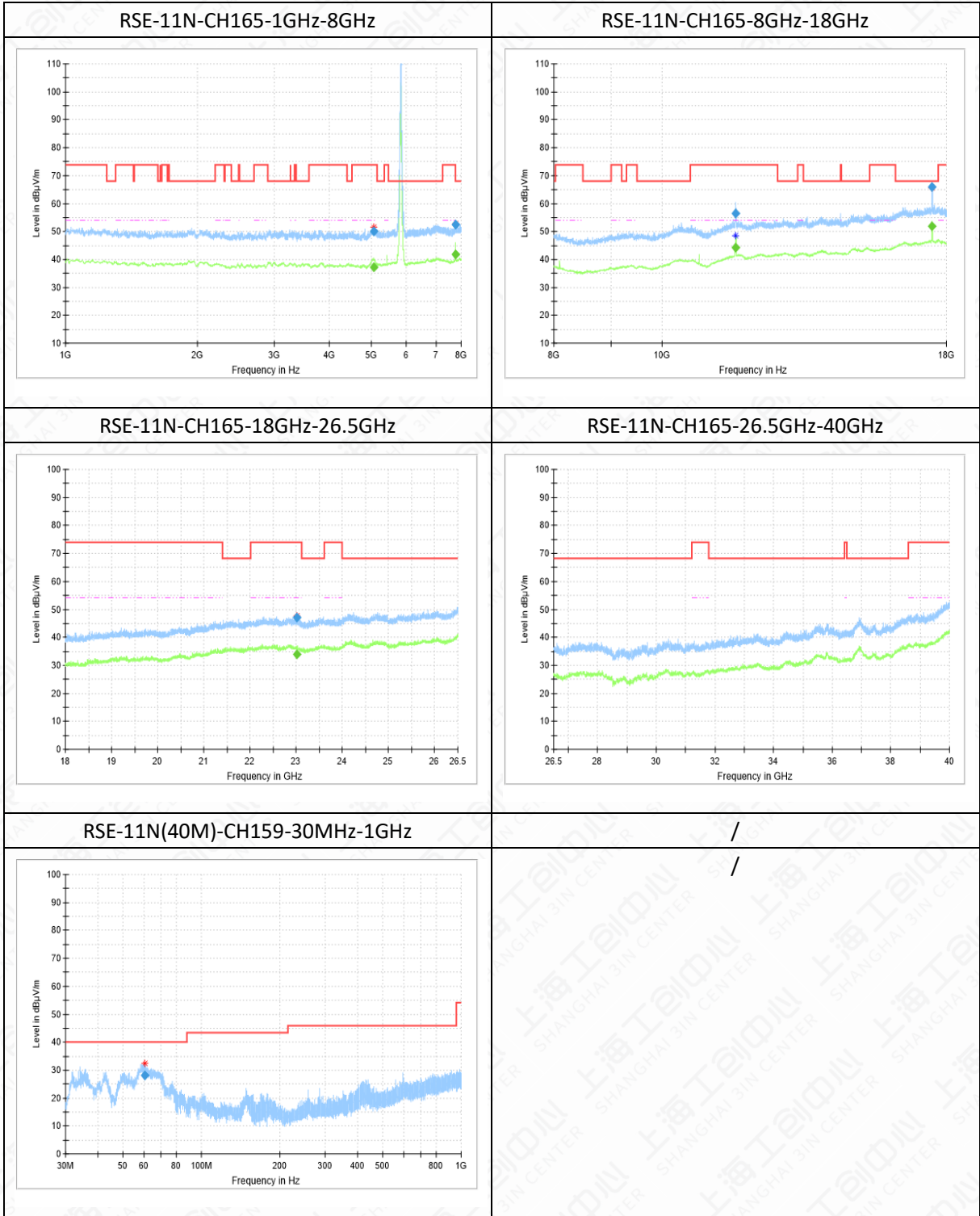

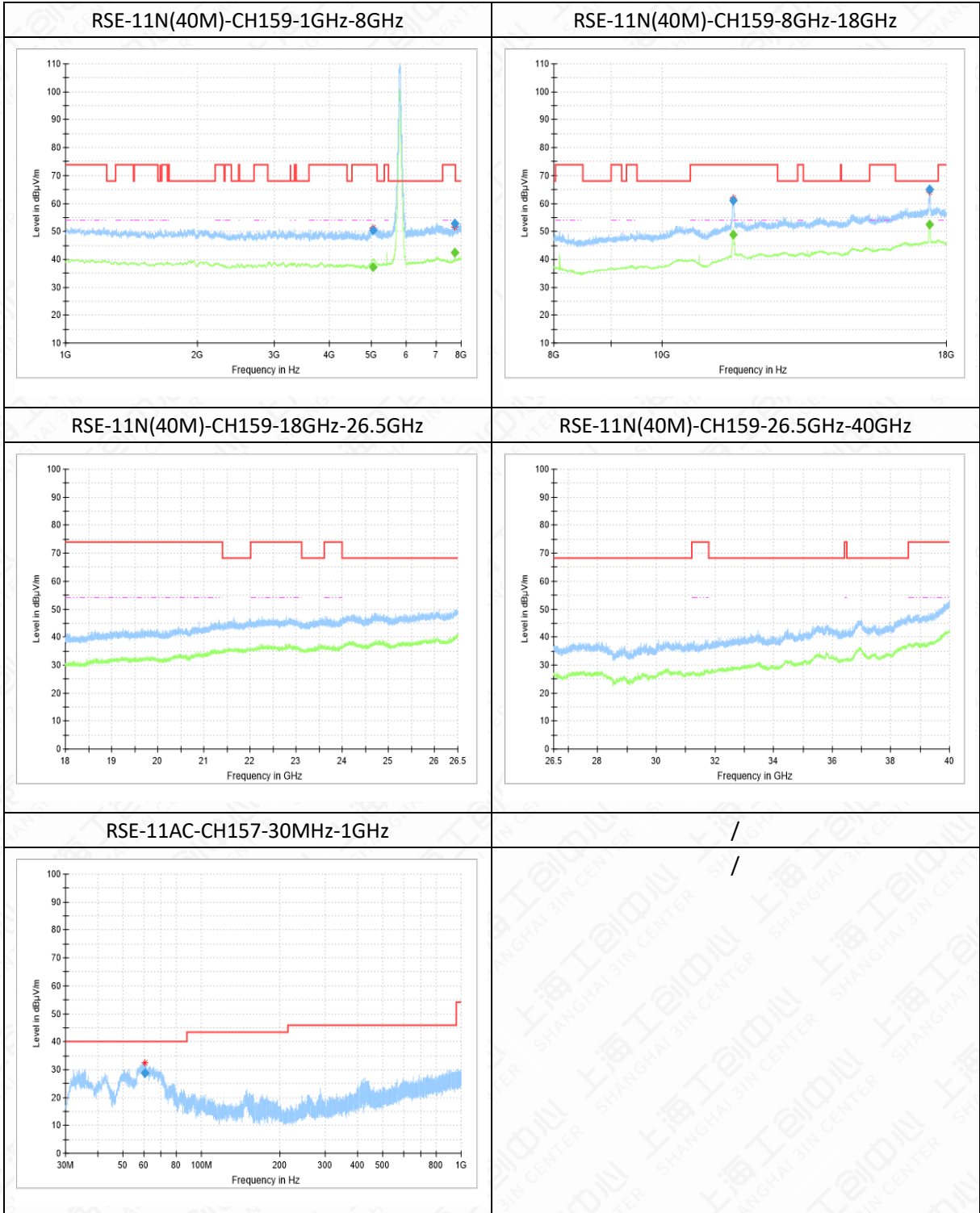

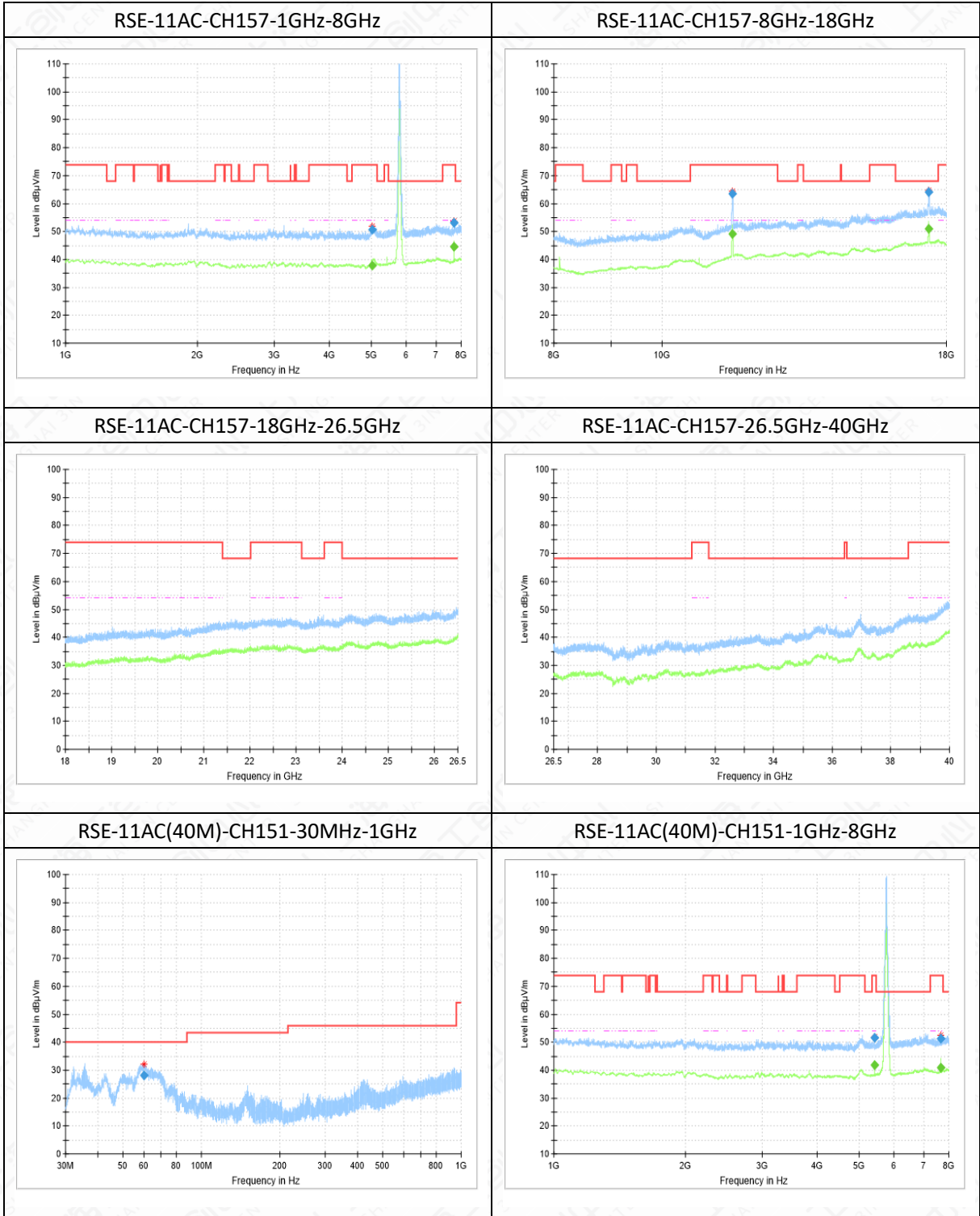



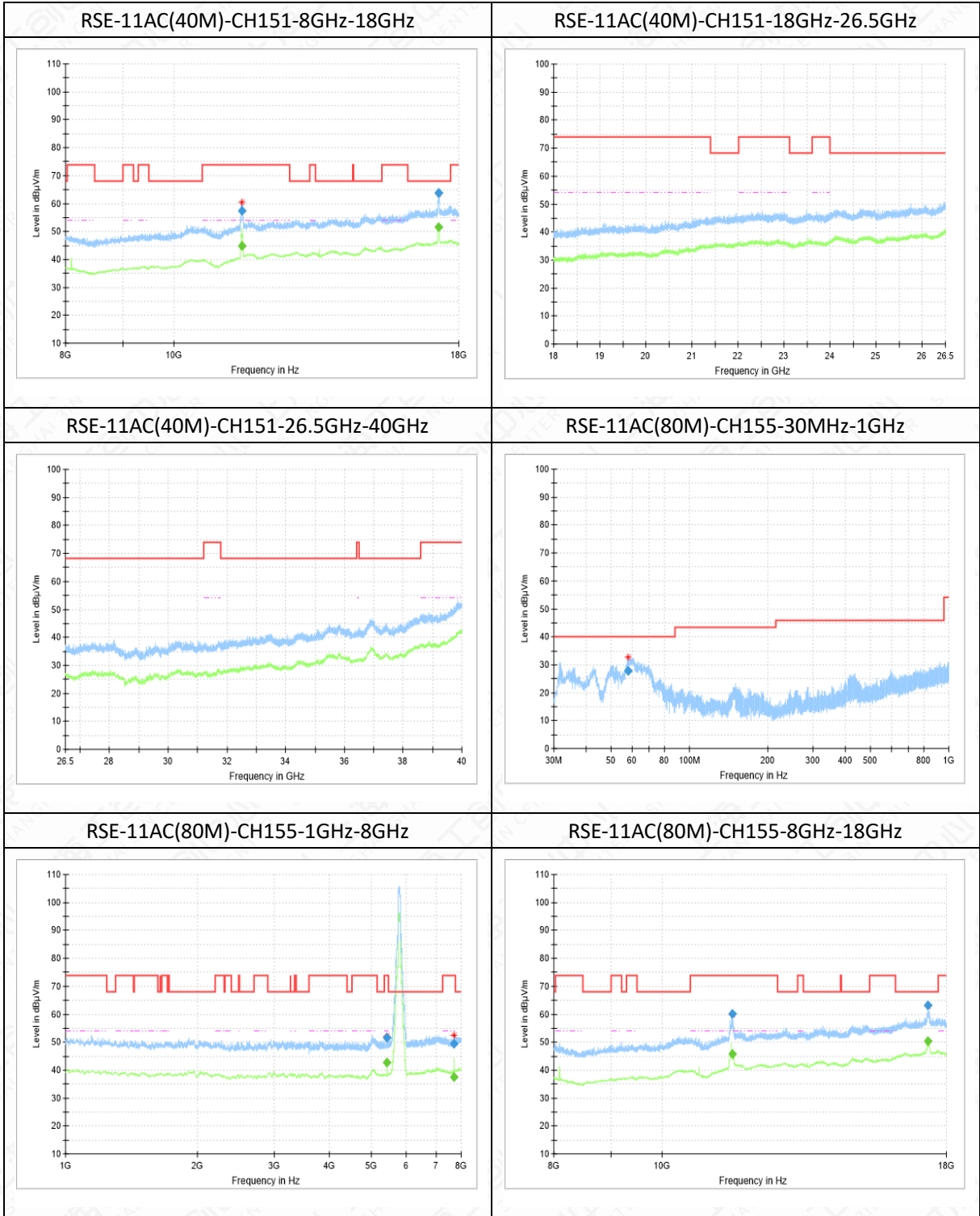

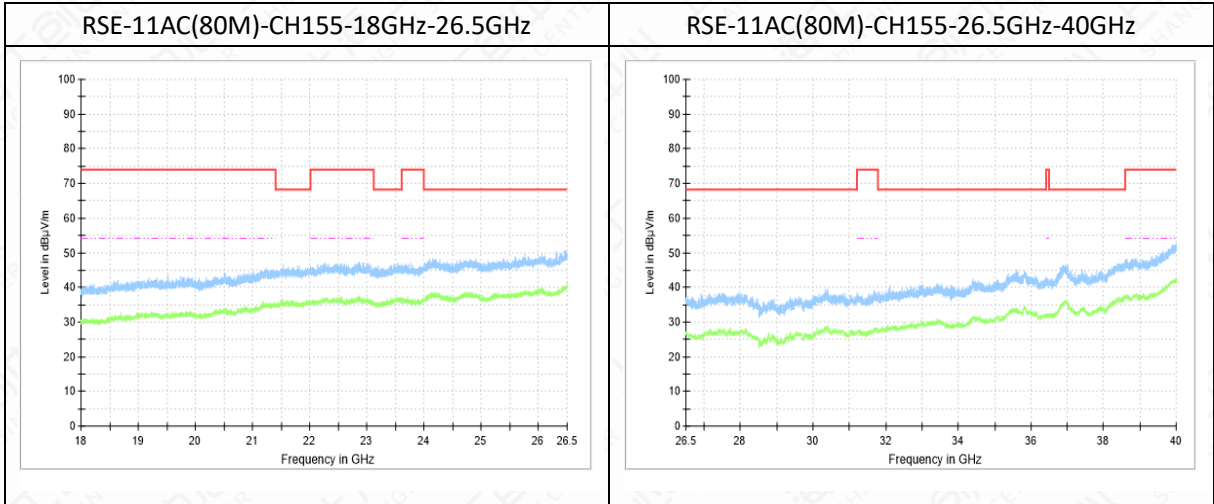

Secondary Supply(S11)

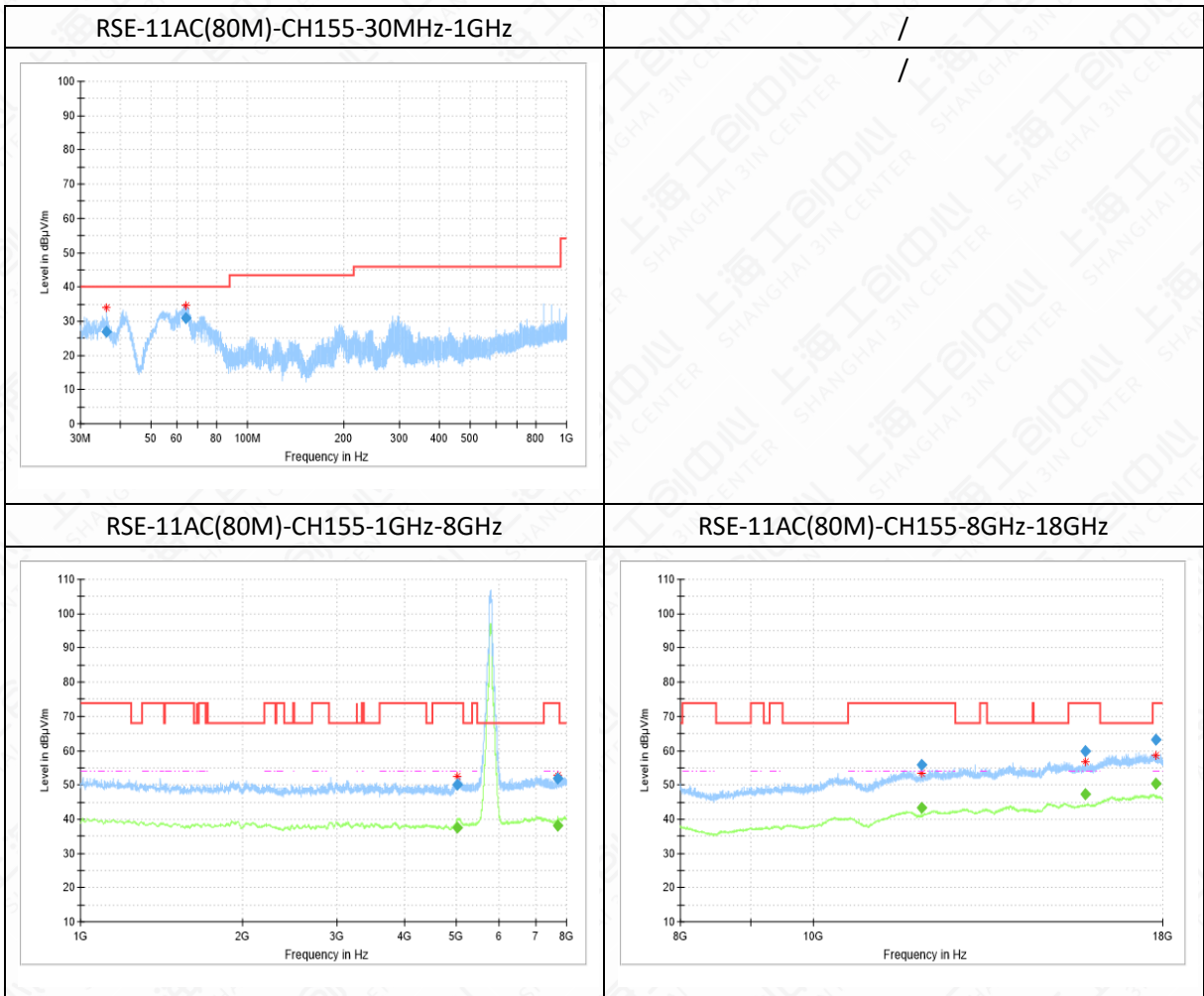

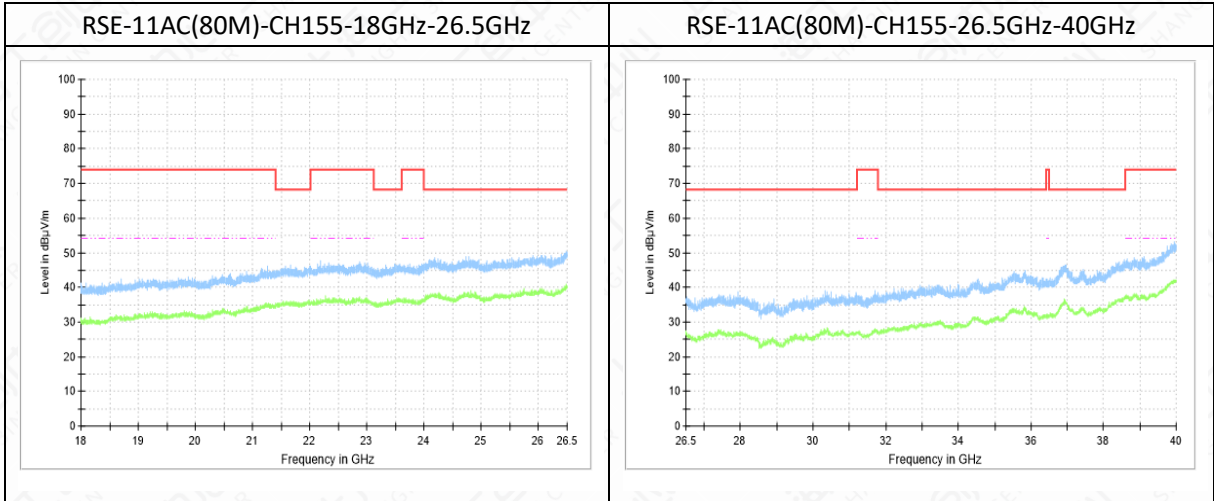

Note:

1. The out-of-limit signal in the picture is the main frequency signal.
2. Only data in worst mode is provided.
3. The test data below 30MHz is more than 20dB lower than the limit value, so it is not provided in the report.



## Mainly Supply(S02)

## RSE-11A-CH165-30MHz-1GHz

Frequency (MHz)	QuasiPeak(dBμV/m)	ARpl (dB)	PMea (dBμV/m)	Margin(dB)	Limit(dBμV/m)	Polarity
60.8	28.82	-13	41.82	11.18	40.00	V

## RSE-11A-CH165-1GHz-8GHz

Frequency (MHz)	MaxPeak(dBμV/m)	ARpl (dB)	PMea (dBμV/m)	Margin(dB)	Limit(dBμV/m)	Polarity
3408.0	46.4	1	45.4	21.80	68.20	V
5400.0	52.16	2	50.16	21.84	74.00	V
7766.8	53.74	4	49.74	14.46	68.20	H

## RSE-11A-CH165-1GHz-8GHz

Frequency (MHz)	Average(dBμV/m)	ARpl (dB)	PMea (dBμV/m)	Margin(dB)	Limit(dBμV/m)	Polarity
3408.0	33.66	1	32.66	---	---	V
5400.0	43.24	2	41.24	10.76	54.00	V
7766.8	44.16	4	40.16	---	---	H

## RSE-11A-CH165-8GHz-18GHz

Frequency (MHz)	MaxPeak(dBμV/m)	ARpl (dB)	PMea (dBμV/m)	Margin(dB)	Limit(dBμV/m)	Polarity
11655.0	63.68	10	53.68	10.32	74.00	H
17476.5	65.16	18	47.16	3.04	68.20	H

## RSE-11A-CH165-8GHz-18GHz

Frequency (MHz)	Average(dBμV/m)	ARpl (dB)	PMea (dBμV/m)	Margin(dB)	Limit(dBμV/m)	Polarity
11655.0	49.58	10	39.58	4.42	54.00	H
17476.5	52.35	18	34.35	---	---	H

## RSE-11A-CH165-18GHz-26.5GHz

Frequency (MHz)	MaxPeak(dBμV/m)	ARpl (dB)	PMea (dBμV/m)	Margin(dB)	Limit(dBμV/m)	Polarity
21290.8	46.04	-2	48.04	27.96	74.00	V

## RSE-11N-CH165-30MHz-1GHz

Frequency (MHz)	QuasiPeak(dBμV/m)	ARpl (dB)	PMea (dBμV/m)	Margin(dB)	Limit(dBμV/m)	Polarity
60.7	28.91	-13	41.91	11.09	40.00	V

## RSE-11N-CH165-1GHz-8GHz

Frequency (MHz)	MaxPeak(dBμV/m)	ARpl (dB)	PMea (dBμV/m)	Margin(dB)	Limit(dBμV/m)	Polarity
5052.2	50.2	5	45.2	23.80	74.00	H
7766.8	52.36	4	48.36	15.84	68.20	H

## RSE-11N-CH165-1GHz-8GHz

Frequency (MHz)	Average(dBμV/m)	ARpl (dB)	PMea (dBμV/m)	Margin(dB)	Limit(dBμV/m)	Polarity
5052.2	37.31	5	32.31	16.69	54.00	H
7766.8	41.81	4	37.81	---	---	H

## RSE-11N-CH165-8GHz-18GHz

Frequency (MHz)	MaxPeak(dBμV/m)	ARpl (dB)	PMea (dBμV/m)	Margin(dB)	Limit(dBμV/m)	Polarity
11647.2	56.41	10	46.41	17.59	74.00	H
17476.0	65.85	18	47.85	2.35	68.20	H

## RSE-11N-CH165-8GHz-18GHz

Frequency (MHz)	Average(dBμV/m)	ARpl (dB)	PMea (dBμV/m)	Margin(dB)	Limit(dBμV/m)	Polarity
11647.2	44.15	10	34.15	9.85	54.00	H
17476.0	51.93	18	33.93	---	---	H

## RSE-11N-CH165-18GHz-26.5GHz

Frequency (MHz)	MaxPeak(dBμV/m)	ARpl (dB)	PMea (dBμV/m)	Margin(dB)	Limit(dBμV/m)	Polarity
23020.5	47.77	-1	48.77	26.23	74.00	H

## RSE-11N(40M)-CH159-30MHz-1GHz

Frequency (MHz)	QuasiPeak(dBμV/m)	ARpl (dB)	PMea (dBμV/m)	Margin(dB)	Limit(dBμV/m)	Polarity
60.7	28.27	-13	41.27	11.73	40.00	V

## RSE-11N(40M)-CH159-1GHz-8GHz

Frequency (MHz)	MaxPeak(dBμV/m)	ARpl (dB)	PMea (dBμV/m)	Margin(dB)	Limit(dBμV/m)	Polarity
5032.4	50.42	5	45.42	23.58	74.00	V
7726.5	52.78	4	48.78	21.22	74.00	V

## RSE-11N(40M)-CH159-1GHz-8GHz

Frequency (MHz)	Average(dBμV/m)	ARpl (dB)	PMea (dBμV/m)	Margin(dB)	Limit(dBμV/m)	Polarity
5032.4	37.1	5	32.1	16.90	54.00	V



7726.5	42.52	4	38.52	11.48	54.00	V
--------	-------	---	-------	-------	-------	---

## RSE-11N(40M)-CH159-8GHz-18GHz

Frequency (MHz)	MaxPeak(dBμV/m)	ARpl (dB)	PMea (dBμV/m)	Margin(dB)	Limit(dBμV/m)	Polarity
11589.5	61.17	10	51.17	12.83	74.00	H
17386.8	65.17	18	47.17	3.03	68.20	H

## RSE-11N(40M)-CH159-8GHz-18GHz

Frequency (MHz)	Average(dBμV/m)	ARpl (dB)	PMea (dBμV/m)	Margin(dB)	Limit(dBμV/m)	Polarity
11589.5	48.92	10	38.92	5.08	54.00	H
17386.8	52.56	18	34.56	---	---	H

## RSE-11AC-CH157-30MHz-1GHz

Frequency (MHz)	QuasiPeak(dBμV/m)	ARpl (dB)	PMea (dBμV/m)	Margin(dB)	Limit(dBμV/m)	Polarity
60.7	28.68	-13	41.68	11.32	40.00	V

## RSE-11AC-CH157-1GHz-8GHz

Frequency (MHz)	MaxPeak(dBμV/m)	ARpl (dB)	PMea (dBμV/m)	Margin(dB)	Limit(dBμV/m)	Polarity
5010.9	50.78	5	45.78	23.22	74.00	H
7713.4	53.22	4	49.22	20.78	74.00	H

## RSE-11AC-CH157-1GHz-8GHz

Frequency (MHz)	Average(dBμV/m)	ARpl (dB)	PMea (dBμV/m)	Margin(dB)	Limit(dBμV/m)	Polarity
5010.9	37.69	5	32.69	16.31	54.00	H
7713.4	44.6	4	40.6	9.40	54.00	H

## RSE-11AC-CH157-8GHz-18GHz

Frequency (MHz)	MaxPeak(dBμV/m)	ARpl (dB)	PMea (dBμV/m)	Margin(dB)	Limit(dBμV/m)	Polarity
11573.0	63.5	10	53.5	10.50	74.00	H
17357.2	64.08	18	46.08	4.12	68.20	H

## RSE-11AC-CH157-8GHz-18GHz

Frequency (MHz)	Average(dBμV/m)	ARpl (dB)	PMea (dBμV/m)	Margin(dB)	Limit(dBμV/m)	Polarity
11573.0	49.29	10	39.29	4.71	54.00	H
17357.2	50.85	18	32.85	---	---	H



**RSE-11AC(40M)-CH151-30MHz-1GHz**

Frequency (MHz)	QuasiPeak(dBμV/m)	ARpl (dB)	PMea (dBμV/m)	Margin(dB)	Limit(dBμV/m)	Polarity
60.0	28.14	-12	40.14	11.86	40.00	V

**RSE-11AC(40M)-CH151-1GHz-8GHz**

Frequency (MHz)	MaxPeak(dBμV/m)	ARpl (dB)	PMea (dBμV/m)	Margin(dB)	Limit(dBμV/m)	Polarity
5399.9	51.54	2	49.54	22.46	74.00	V
7673.1	51.34	4	47.34	22.66	74.00	V

**RSE-11AC(40M)-CH151-1GHz-8GHz**

Frequency (MHz)	Average(dBμV/m)	ARpl (dB)	PMea (dBμV/m)	Margin(dB)	Limit(dBμV/m)	Polarity
5399.9	41.66	2	39.66	12.34	54.00	V
7673.1	40.97	4	36.97	13.03	54.00	V

**RSE-11AC(40M)-CH151-8GHz-18GHz**

Frequency (MHz)	MaxPeak(dBμV/m)	ARpl (dB)	PMea (dBμV/m)	Margin(dB)	Limit(dBμV/m)	Polarity
11501.0	57.36	9	48.36	16.64	74.00	H
17264.5	63.75	18	45.75	4.45	68.20	H

**RSE-11AC(40M)-CH151-8GHz-18GHz**

Frequency (MHz)	Average(dBμV/m)	ARpl (dB)	PMea (dBμV/m)	Margin(dB)	Limit(dBμV/m)	Polarity
11501.0	44.9	9	35.9	9.10	54.00	H
17264.5	51.57	18	33.57	---	---	H

**RSE-11AC(80M)-CH155-30MHz-1GHz**

Frequency (MHz)	QuasiPeak(dBμV/m)	ARpl (dB)	PMea (dBμV/m)	Margin(dB)	Limit(dBμV/m)	Polarity
58.0	27.78	-12	39.78	12.22	40.00	V

**RSE-11AC(80M)-CH155-1GHz-8GHz**

Frequency (MHz)	MaxPeak(dBμV/m)	ARpl (dB)	PMea (dBμV/m)	Margin(dB)	Limit(dBμV/m)	Polarity
5399.9	51.69	2	49.69	22.31	74.00	V
7699.8	49.56	4	45.56	24.44	74.00	V

**RSE-11AC(80M)-CH155-1GHz-8GHz**

Frequency (MHz)	Average(dBμV/m)	ARpl (dB)	PMea (dBμV/m)	Margin(dB)	Limit(dBμV/m)	Polarity
5399.9	42.6	2	40.6	11.40	54.00	V

7699.8	37.43	4	33.43	16.57	54.00	V
--------	-------	---	-------	-------	-------	---

## RSE-11AC(80M)-CH155-8GHz-18GHz

Frequency (MHz)	MaxPeak(dBμV/m)	ARpl (dB)	PMea (dBμV/m)	Margin(dB)	Limit(dBμV/m)	Polarity
11566.8	60.13	10	50.13	13.87	74.00	H
17322.0	63.06	18	45.06	5.14	68.20	H

## RSE-11AC(80M)-CH155-8GHz-18GHz

Frequency (MHz)	Average(dBμV/m)	ARpl (dB)	PMea (dBμV/m)	Margin(dB)	Limit(dBμV/m)	Polarity
11566.8	45.72	10	35.72	8.28	54.00	H
17322.0	50.49	18	32.49	---	---	H

## Secondary Supply(S11)

## RSE-11AC(80M)-CH155-30MHz-1GHz

Frequency (MHz)	QuasiPeak(dBμV/m)	ARpl (dB)	PMea (dBμV/m)	Margin(dB)	Limit(dBμV/m)	Polarity
36.3	26.78	-14	40.78	13.22	40.00	V
63.9	30.9	-14	44.9	9.10	40.00	V

## RSE-11AC(80M)-CH155-1GHz-8GHz

Frequency (MHz)	MaxPeak(dBμV/m)	ARpl (dB)	PMea (dBμV/m)	Margin(dB)	Limit(dBμV/m)	Polarity
5012.2	50.17	5	45.17	23.83	74.00	H
7700.2	51.75	4	47.75	22.25	74.00	H

## RSE-11AC(80M)-CH155-1GHz-8GHz

Frequency (MHz)	Average(dBμV/m)	ARpl (dB)	PMea (dBμV/m)	Margin(dB)	Limit(dBμV/m)	Polarity
5012.2	37.56	5	32.56	16.44	54.00	H
7700.2	38.21	4	34.21	15.79	54.00	H

## RSE-11AC(80M)-CH155-8GHz-18GHz

Frequency (MHz)	MaxPeak(dBμV/m)	ARpl (dB)	PMea (dBμV/m)	Margin(dB)	Limit(dBμV/m)	Polarity
11998.5	56.02	10	46.02	17.98	74.00	V
15792.5	59.9	15	44.9	14.10	74.00	V
17793.8	63.21	18	45.21	10.79	74.00	V



**RSE-11AC(80M)-CH155-8GHz-18GHz**

Frequency (MHz)	Average(dBμV/m)	ARpl (dB)	PMea (dBμV/m)	Margin(dB)	Limit(dBμV/m)	Polarity
11998.5	43.35	10	33.35	10.65	54.00	V
15792.5	47.24	15	32.24	6.76	54.00	V
17793.8	50.36	18	32.36	3.64	54.00	V



## 6.8 Band Edges Compliance (Radiated)

### 6.8.1 Measurement Limit

#### Above 1G, non-restricted band

Standard	Limit
15.407(b)	EIRP < -27dBm/MHz
RSS-247 6.2	EIRP < -27dBm/MHz

#### Above 1G, Restricted band

Standard	Limit	
15.407(b)	EIRP < -27dBm/MHz	
15.209	Peak	74dB $\mu$ V/m
	Average	54dB $\mu$ V/m
RSS-247 6.2	EIRP < -27dBm/MHz	
RSS-Gen 8.9	Peak	74dB $\mu$ V/m
	Average	54dB $\mu$ V/m

$$\text{EIRP[dBm]} = \text{E[dB}\mu\text{V/m]} + 20 \log(d[\text{m}]) - 104.7$$

$$\text{E[dB}\mu\text{V/m]} = \text{EIRP[dBm]} - 20 \log(d[\text{m}]) + 104.7$$

$$\text{E[dB}\mu\text{V/m]} = \text{EIRP[dBm]} + 95.2 = 68.2, \text{ for } d = 3\text{m}$$

### 6.8.2 Test Procedure

The measurement is made according to KDB 789033.

Marker-Delta Method: The marker-delta method, as described in ANSI C63.10, can be used to perform measurements of the radiated unwanted emissions level of emissions provided that the 99% occupied bandwidth of the fundamental is within 2 MHz of the authorized band-edge.

#### Procedure for peak unwanted emissions measurements above 1000 MHz

The procedure for peak unwanted emissions measurements above 1000 MHz is as follows:

- a) Follow the requirements in 12.7.4.
- b) Peak emission levels are measured by setting the instrument as follows:
  - 1) RBW = 1 MHz.
  - 2) VBW  $\geq$  [3  $\times$  RBW].
  - 3) Detector = peak.
  - 4) Sweep time = auto.
  - 5) Trace mode = max hold.
  - 6) Allow sweeps to continue until the trace stabilizes. Note that if the transmission is not continuous, then the time required for the trace to stabilize will increase by a factor of approximately 1 / D, where D is the duty cycle. For example, at 50% duty cycle, the measurement time will increase by a factor of two, relative to measurement time for continuous transmission.

#### Procedures for average unwanted emissions measurements above 1000 MHz

- a) RBW = 1 MHz.

## b) Video bandwidth:

1) If the EUT is configured to transmit with  $D \geq 98\%$ , then set  $VBW \leq RBW / 100$  (i.e., 10 kHz), but not less than 10 Hz.

2) If the EUT  $D$  is  $< 98\%$ , then set  $VBW \geq 1 / T$ , where  $T$  is defined in item a1) of 12.2.

## c) Video bandwidth mode or display mode:

1) The instrument shall be set with video filtering applied in the power domain. Typically, this requires setting the detector mode to RMS (power averaging) and setting the average-VBW type to power (rms).

2) As an alternative, the instrument may be set to linear detector mode. Video filtering shall be applied in linear voltage domain (rather than in a log or dB domain). Some instruments require linear display mode to accomplish this. Others have a setting for average-VBW type, which can be set to "voltage" regardless of the display mode.

## d) Detector = peak.

## e) Sweep time = auto.

## f) Trace mode = max hold.

g) Allow max hold to run for at least 50 traces if the transmitted signal is continuous or has at least 98% duty cycle. For lower duty cycles, increase the minimum number of traces by a factor of  $1/x$ , where  $D$  is the duty cycle. For example, use at least 200 traces if the duty cycle is 25%. (If a specific emission is demonstrated to be continuous—i.e., 100% duty cycle—then rather than turning ON and OFF with the transmit cycle, at least 50 traces should be averaged.)

The measurement was applied in a fully anechoic chamber. While testing for spurious emission higher than 1GHz, if applied, the pre-amplifier would be equipped just at the output terminal of the antenna. Tabletop devices shall be placed on a nonconducting platform with nominal top surface dimensions 1 m by 1.5 m. For emission measurements above 1 GHz, the table height shall be 1.5 m. The turntable rotated 360 degrees to determine the position of the maximum emission level. The EUT was set 3 meters away from the receiving antenna which was mounted on an antenna mast. During the tests, the antenna height varied from 1m to 4m and the EUT azimuth were varied from  $0^\circ$  to  $360^\circ$  in order to identify the maximum level of emissions from the EUT. In making any tests involving handheld, body-worn, or ceiling-mounted equipment, it is essential to recognize that the measured levels may be dependent on the orientation (attitude) of the three orthogonal axes of the EUT. Thus, exploratory tests as specified in 8.3.1 shall be carried out for various axes orientations to determine the attitude having maximum or near-maximum emission level. This maximization process was repeated with the EUT positioned in each of its three orthogonal orientations.

### 6.8.3 Test Setup



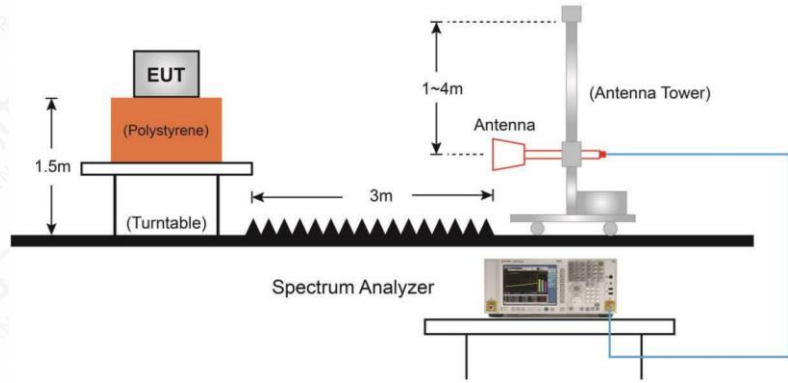

6.8.4 Measurement Result

Mode	Channel	Conclusion
802.11a	149	P
	165	P
802.11n HT20	149	P
	161	P
	165	P
802.11n HT40	151	P
	159	P
802.11ac VHT20	149	P
	165	P
802.11ac VHT40	151	P
	159	P
802.11ac VHT80	155	P

Test graphs as below:

Mainly Supply(S02)

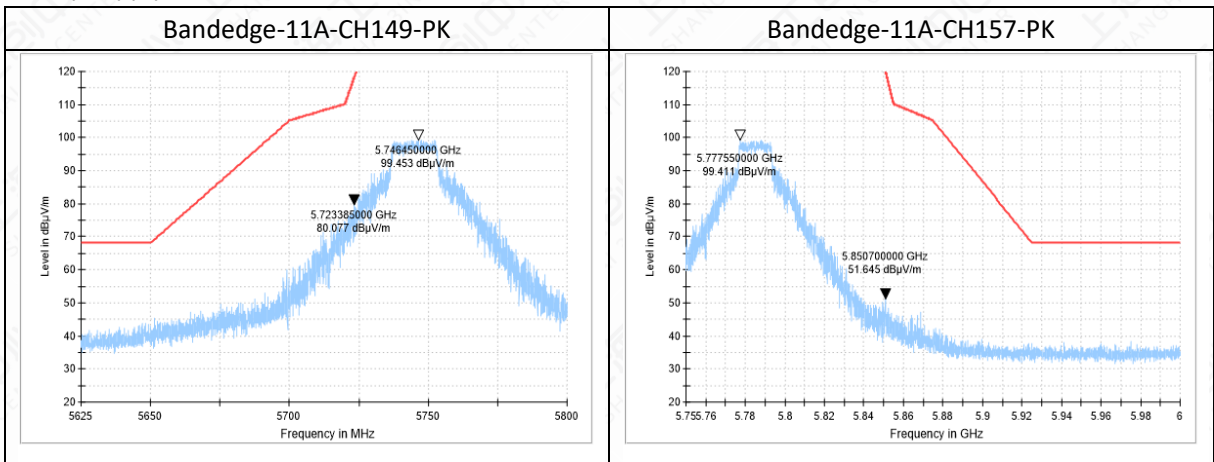



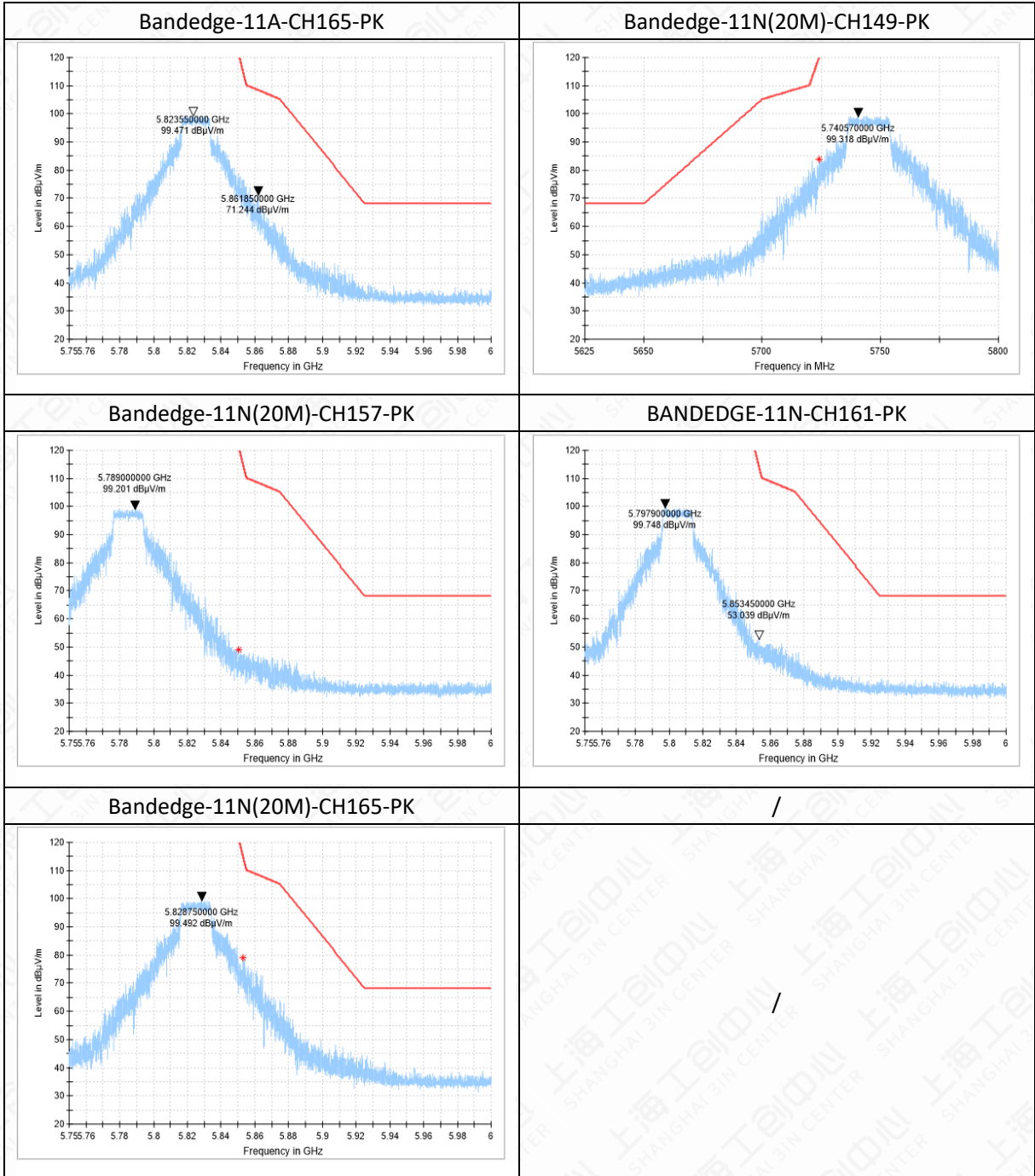

Bandedge-11N(40M)-CH151-PK

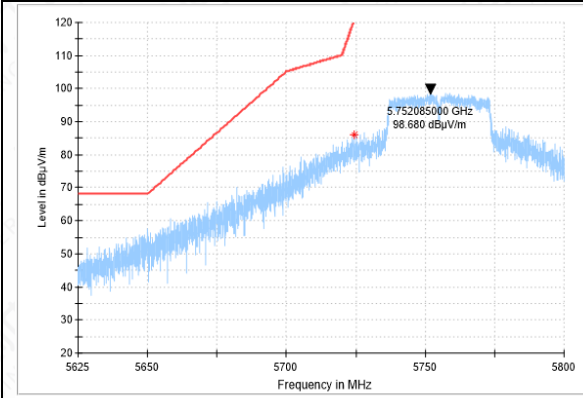

Bandedge-11N(40M)-CH159-PK

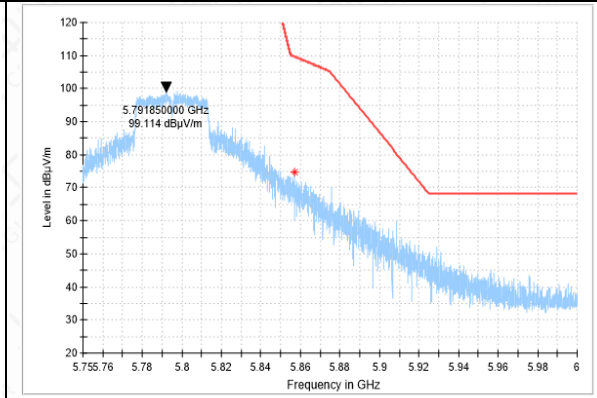

Bandedge-11AC(20M)-CH149-PK

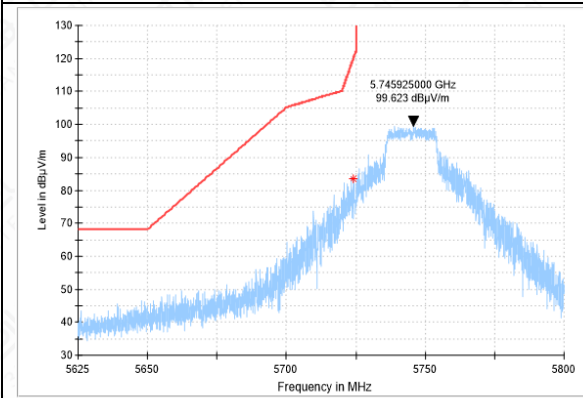

Bandedge-11AC(20M)-CH157-PK

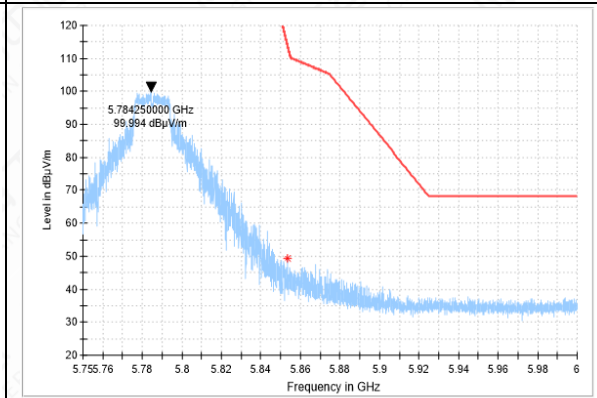

Bandedge-11AC(20M)-CH165-PK

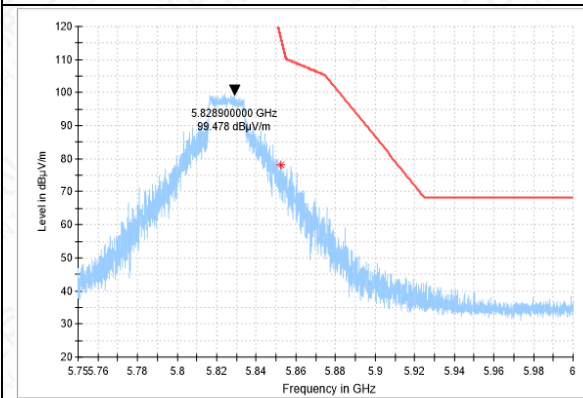

Bandedge-11AC(40M)-CH151-PK

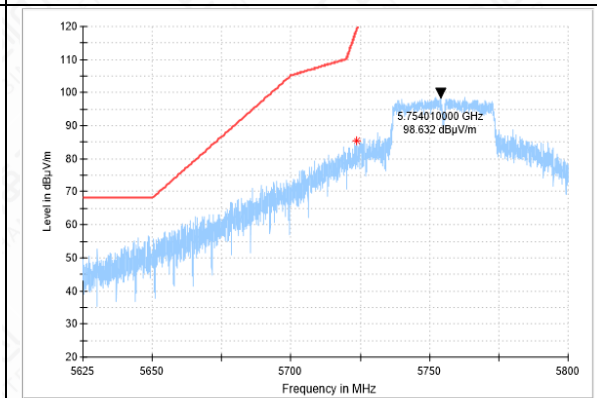



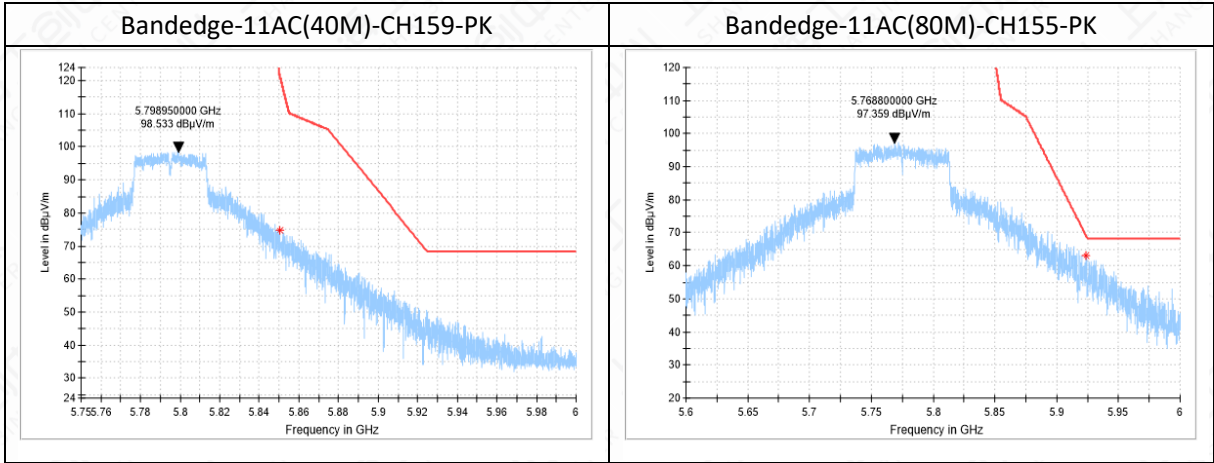

Secondary Supply(S11)

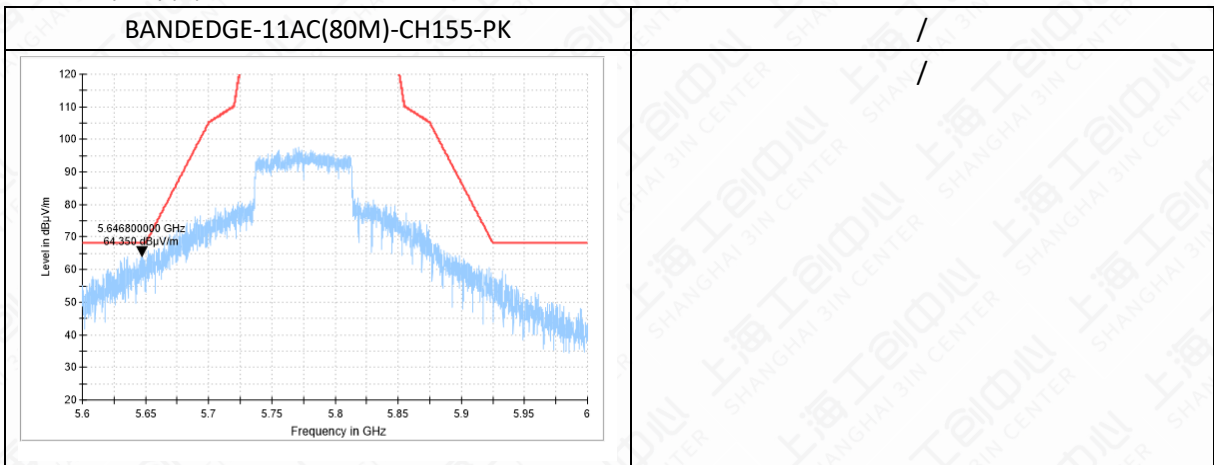

Note: Only data in worst mode is provided.



## 6.9 AC Powerline Conducted Emission

### 6.9.1 Method of Measurement: ANSI C63.10-2013-clause 6.2

1. The one EUT cable configuration and arrangement and mode of operation that produced the emission with the highest amplitude relative to the limit is selected for the final measurement, while applying the appropriate modulating signal to the EUT.
2. If the EUT is relocated from an exploratory test site to a final test site, the highest emissions shall be remaximized at the final test location before final ac power-line conducted emission measurements are performed.
3. The final test on all current-carrying conductors of all of the power cords to the equipment that comprises the EUT (but not the cords associated with other non-EUT equipment in the system) is then performed for the full frequency range for which the EUT is being tested for compliance without further variation of the EUT arrangement, cable positions, or EUT mode of operation.
4. If the EUT is comprised of equipment units that have their own separate ac power connections, e.g., floor-standing equipment with independent power cords for each shelf that are able to connect directly to the ac power network, each current-carrying conductor of one unit is measured while the other units are connected to a second (or more) LISN(s). All units shall be separately measured. If a power strip is provided by the manufacturer, to supply all of the units making up the EUT, only the conductors in the power cord of the power strip shall be measured.

If the EUT uses a detachable antenna, these measurements shall be made with a suitable dummy load connected to the antenna output terminals; otherwise, the tests shall be made with the antenna connected and, if adjustable, fully extended. When measuring the ac conducted emissions from a device that operates between 150 kHz and 30 MHz a non-detachable antenna may be replaced with a dummy load for the measurements within the fundamental emission band of the transmitter, but only for those measurements.<sup>36</sup> Record the six highest EUT emissions relative to the limit of each of the current-carrying conductors of the power cords of the equipment that comprises the EUT over the frequency range specified by the procuring or regulatory agency. Diagram or photograph the test setup that was used. See Clause 8 for full reporting requirements.

6.9.2 Test Setup

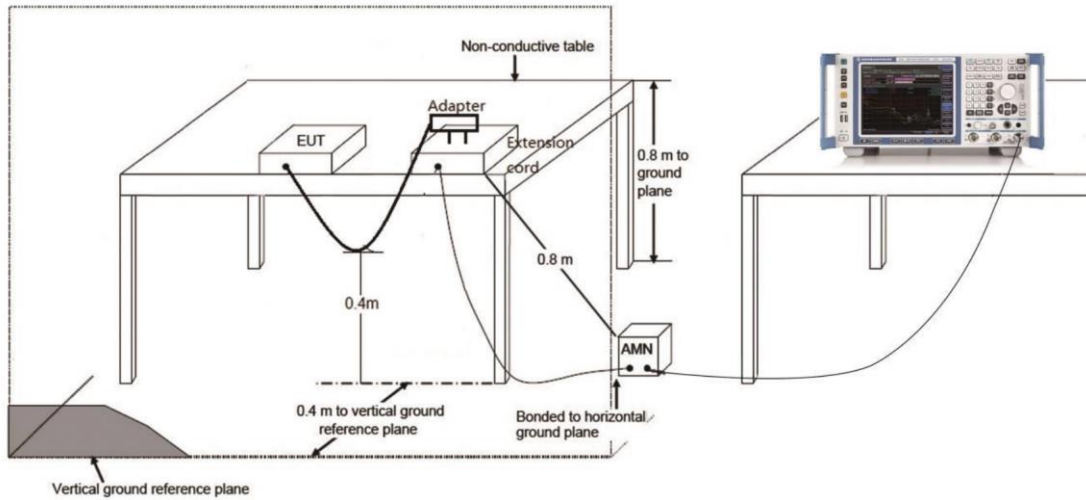

6.9.3 Test Condition

Voltage (V)	Frequency (Hz)
120	60

6.9.4 Measurement limit

(Quasi-peak-average Limit)

Frequency range (MHz)	Quasi-peak Limit (dB $\mu$ V)	Average Limit (dB $\mu$ V)	Conclusion
0.15 to 0.5	66 to 56	56 to 46	P
0.5 to 5	56	46	
5 to 30	60	50	

NOTE: The limit decreases linearly with the logarithm of the frequency in the range 0.15 MHz to 0.5 MHz.



## 6.9.5 Measurement Result

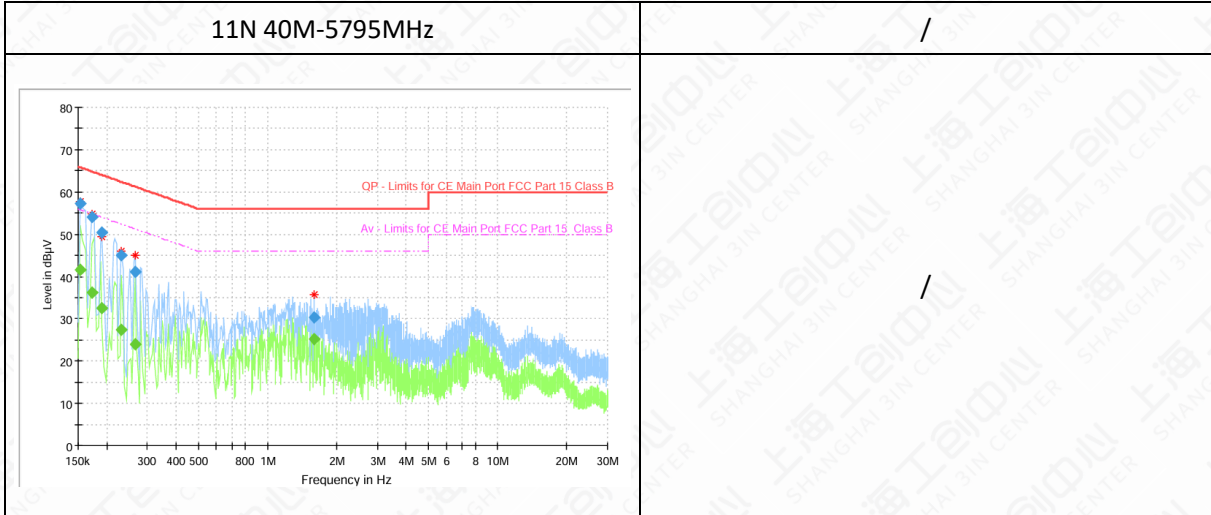

Frequency (MHz)	QuasiPeak (dBμV)	Average (dBμV)	Limit (dBμV)	Margin (dB)	Meas. Time (ms)	Bandwidth (kHz)	Line	Filter	Corr. (dB)
0.153731	---	41.51	55.80	14.28	15000.0	9.000	L1	ON	9.6
0.153731	57.27	---	65.80	8.52	15000.0	9.000	L1	ON	9.6
0.172388	---	36.18	54.85	18.67	15000.0	9.000	L1	ON	9.6
0.172388	54.03	---	64.85	10.81	15000.0	9.000	L1	ON	9.6
0.191044	---	32.55	53.99	21.44	15000.0	9.000	L1	ON	9.6
0.191044	50.32	---	63.99	13.67	15000.0	9.000	L1	ON	9.6
0.232088	---	27.37	52.38	25.01	15000.0	9.000	L1	ON	9.6
0.232088	44.99	---	62.38	17.38	15000.0	9.000	L1	ON	9.6
0.265669	---	24.06	51.25	27.19	15000.0	9.000	L1	ON	9.6
0.265669	41.21	---	61.25	20.04	15000.0	9.000	L1	ON	9.6
1.590263	---	25.26	46.00	20.74	15000.0	9.000	L1	ON	9.6
1.590263	30.35	---	56.00	25.65	15000.0	9.000	L1	ON	9.6

Note:

L1 and N is all have been tested, the result of them is synthesized in the above data diagram.



**Annex A: Revised History**

Version	Revised Content
V00	Initial

Annex B: Accreditation Certificate



### Accredited Laboratory

A2LA has accredited

## INDUSTRIAL INTERNET INNOVATION CENTER (SHANGHAI) CO., LTD.

Shanghai, People's Republic of China

for technical competence in the field of

### Electrical Testing

This laboratory is accredited in accordance with the recognized International Standard ISO/IEC 17025:2017 *General requirements for the competence of testing and calibration laboratories*. This accreditation demonstrates technical competence for a defined scope and the operation of a laboratory quality management system (refer to joint ISO-ILAC-IAF Communiqué dated April 2017).



Presented this 20<sup>th</sup> day of September 2023.



Mr. Trace McInturff, Vice President, Accreditation Services  
For the Accreditation Council  
Certificate Number 3682.01  
Valid to February 28, 2025

For the tests to which this accreditation applies, please refer to the laboratory's Electrical Scope of Accreditation.

END OF REPORT