

FCC Report (GSM&WCDMA)

Applicant: Shanghai Sunmi Technology Co.,Ltd.
Address of Applicant: Room 605, Block 7, KIC Plaza, No.388 Song Hu Road Yang Pu District, Shanghai 200433, China
Manufacturer: Shanghai Sunmi Technology Co.,Ltd.
Address of Manufacturer: Room 605, Block 7, KIC Plaza, No.388 Song Hu Road Yang Pu District, Shanghai 200433, China

Equipment Under Test (EUT)

Product Name: POS System
Model No.: W3500
Marketing Name: D1
FCC ID: 2AH25D1
Applicable standards: FCC CFR Title 47 Part 2: 2016
FCC CFR Title 47 Part22 Subpart H: 2016
FCC CFR Title 47 Part24 Subpart E: 2016
Date of sample receipt: May 27, 2017
Date of Test: May 28-June 14, 2017
Date of report issued: June 15, 2017
Test Result : PASS *

* In the configuration tested, the EUT complied with the standards specified above.

Authorized Signature:



Robinson Lo
Laboratory Manager

This results shown in this test report refer only to the sample(s) tested, this test report cannot be reproduced, except in full, without prior written permission of the company. The report would be invalid without specific stamp of test institute and the signatures of compiler and approver.

2 Version

Version No.	Date	Description
00	June 15, 2017	Original

Prepared By:

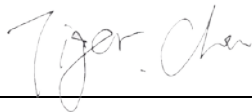

Date:

June 15, 2017

Project Engineer

Check By:

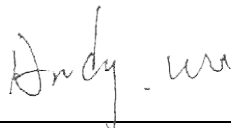

Date:

June 15, 2017

Reviewer

3 Contents

Page

1	COVER PAGE	1
2	VERSION	2
3	CONTENTS	3
4	TEST SUMMARY	4
5	GENERAL INFORMATION	5
5.1	GENERAL DESCRIPTION OF EUT	5
5.2	RELATED SUBMITTAL(S) / GRANT (S)	7
5.3	TEST METHODOLOGY.....	7
5.4	TEST FACILITY	7
5.5	TEST LOCATION.....	7
6	TEST INSTRUMENTS LIST	8
7	TEST RESULTS	9
7.1	CONDUCTED PEAK OUTPUT POWER	9
7.2	PEAK-TO-AVERAGE RATIO	11
7.3	OCCUPY BANDWIDTH.....	13
7.4	MODULATION CHARACTERISTIC.....	21
7.5	OUT OF BAND EMISSION AT ANTENNA TERMINALS.....	21
7.6	ERP, EIRP MEASUREMENT	31
7.7	FIELD STRENGTH OF SPURIOUS RADIATION MEASUREMENT.....	39
7.8	FREQUENCY STABILITY V.S. TEMPERATURE MEASUREMENT.....	45
7.9	FREQUENCY STABILITY V.S. VOLTAGE MEASUREMENT	49
8	TEST SETUP PHOTO	52
9	EUT CONSTRUCTIONAL DETAILS	52

4 Test Summary

Test Item	Section in CFR 47	Result
RF Exposure (SAR)	Part 1.1307 Part 2.1093	Pass* (Please refer to SAR Report)
RF Output Power	Part 2.1046 Part 22.913 (a)(2) Part 24.232 (c)	Pass
Peak-to-Average Ratio	Part 2.1046 Part 24.232 (d)	Pass
Modulation Characteristics	Part 2.1047	Pass
99% & -26 dB Occupied Bandwidth	Part 2.1049 Part 22.917 Part 24.238	Pass
Spurious Emissions at Antenna Terminal	Part 2.1051 Part 22.917 (a) Part 24.238 (a)	Pass
Field Strength of Spurious Radiation	Part 2.1053 Part 22.917 (a) Part 24.238 (a)	Pass
Out of band emission, Band Edge	Part 22.917 (a) Part 24.238 (a)	Pass
Frequency stability vs. temperature	Part 2.1055(a)(1)(b)	Pass
Frequency stability vs. voltage	Part 2.1055(d)(1)(2)	Pass

Pass: The EUT complies with the essential requirements in the standard.

5 General Information

5.1 General Description of EUT

Product Name:	POS System
Model No.:	W3500
Support Networks:	GPRS, EGPRS, WCDMA
Support Bands:	GSM850, PCS1900, WCDMA Band V, WCDMA Band II
TX Frequency:	GSM850: 824.20MHz-848.80MHz PCS1900: 1850.20MHz-1909.80MHz WCDMA Band V: 826.40MHz-846.60MHz WCDMA Band II: 1852.40MHz -1907.60MHz
GPRS Class:	12
EGPRS Class	12
Modulation type:	GPRS: GMSK EGPRS: GMSK/8PSK WCDMA Band II/V: QPSK
Antenna type:	PCB antenna
Antenna gain:	-2.7dBi(declare by Applicant)
Power supply:	Adapter Model: ADS-65HI-19A-1 24036E Input: AC 100-240V 50/60Hz 1.2A max Output: DC24V 1.5A

Operation Frequency List:

GSM 850		PCS1900		WCDMA Band V		WCDMA Band II	
Channel	Frequency (MHz)	Channel	Frequency (MHz)	Channel	Frequency (MHz)	Channel	Frequency (MHz)
128	824.20	512	1850.20	4132	826.40	9262	1852.40
129	824.40	513	1850.40	4133	826.60	9263	1852.60
· ∴	· ∴	· ∴	· ∴	· ∴	· ∴	· ∴	· ∴
189	836.40	660	1879.80	4181	836.20	9399	1879.80
190	836.60	661	1880.00	4182	836.40	9400	1880.00
191	836.80	662	1880.20	4183	836.60	9401	1880.20
· ∴	· ∴	· ∴	· ∴	· ∴	· ∴	· ∴	· ∴
250	848.60	809	1909.60	4232	846.40	9537	1907.40
251	848.80	810	1909.80	4233	846.60	9538	1907.60

Regards to the operating frequency range over 10 MHz, the Lowest frequency, the middle frequency, and the highest frequency of channel were selected to perform the test, and the selected channel see below:

Final test channel:

GSM 850		PCS1900		WCDMA Band V		WCDMA Band II	
Channel	Frequency (MHz)	Channel	Frequency (MHz)	Channel	Frequency (MHz)	Channel	Frequency (MHz)
128	824.20	512	1850.20	4132	826.40	9262	1852.40
190	836.60	661	1880.00	4183	836.60	9400	1880.00
251	848.80	810	1909.80	4233	846.60	9538	1907.60

5.2 Related Submittal(s) / Grant (s)

This submittal(s) (test report) is filing to comply with Section Part 22 subpart H and Part 24 subpart E of the FCC CFR 47 Rules.

5.3 Test Methodology

Both conducted and radiated testing were performed according to the procedures document on TIA/EIA 603 and FCC CFR 47.1046, 2.1047, 2.1049, 2.1051, 2.1053, 2.1055 and 2.1057

5.4 Test Facility

The test facility is recognized, certified, or accredited by the following organizations:

- **FCC —Registration No.: 600491**

Global United Technology Services Co., Ltd., Shenzhen EMC Laboratory has been registered and fully described in a report filed with the (FCC) Federal Communications Commission. The acceptance letter from the FCC is maintained in files. Registration 600491, June 22, 2016.

- **Industry Canada (IC) —Registration No.: 9079A-2**

The 3m Semi-anechoic chamber of Global United Technology Services Co., Ltd. has been registered by Certification and Engineering Bureau of Industry Canada for radio equipment testing with Registration No.: 9079A-2, August 15, 2016.

5.5 Test Location

All tests were performed at:

Global United Technology Services Co., Ltd.

Address: No. 301-309, 3/F., Jinyuan Business Building, No.2, Laodong Industrial Zone, Xixiang Road, Baoan District, Shenzhen, Guangdong, China 518102

Tel: 0755-27798480

Fax: 0755-27798960

6 Test Instruments list

Item	Test Equipment	Manufacturer	Model No.	Inventory No.	Cal.Date (mm-dd-yy)	Cal.Due date (mm-dd-yy)
1	3m Semi- Anechoic Chamber	ZhongYu Electron	9.0(L)*6.0(W)* 6.0(H)	GTS250	July 03 2015	July 02 2020
2	Control Room	ZhongYu Electron	6.2(L)*2.5(W)* 2.4(H)	GTS251	N/A	N/A
3	EMI Test Receiver	Rohde & Schwarz	ESU26	GTS203	June 29 2016	June 28 2017
4	BiConiLog Antenna	SCHWARZBECK MESS-ELEKTRONIK	VULB9163	GTS214	June 29 2016	June 28 2017
5	Double -ridged waveguide horn	SCHWARZBECK MESS-ELEKTRONIK	9120D-829	GTS208	June 29 2016	June 28 2017
6	Horn Antenna	ETS-LINDGREN	3160	GTS217	June 29 2016	June 28 2017
7	EMI Test Software	AUDIX	E3	N/A	N/A	N/A
8	Coaxial Cable	GTS	N/A	GTS213	June 29 2016	June 28 2017
9	Coaxial Cable	GTS	N/A	GTS211	June 29 2016	June 28 2017
10	Coaxial cable	GTS	N/A	GTS210	June 29 2016	June 28 2017
11	Coaxial Cable	GTS	N/A	GTS212	June 29 2016	June 28 2017
12	Amplifier(100kHz-3GHz)	HP	8347A	GTS204	June 29 2016	June 28 2017
13	Amplifier(2GHz-20GHz)	HP	8349B	GTS206	June 29 2016	June 28 2017
14	Amplifier (18-26GHz)	Rohde & Schwarz	AFS33-18002 650-30-8P-44	GTS218	June 29 2016	June 28 2017
15	Band filter	Amindeon	82346	GTS219	June 29 2016	June 28 2017
16	Universal radio communication tester	Rohde & Schwarz	CMU200	GTS235	June 29 2016	June 28 2017
17	Signal Generator	Rohde & Schwarz	SML03	GTS236	June 29 2016	June 28 2017
18	Temp. Humidity/ Barometer	Oregon Scientific	BA-888	GTS248	June 29 2016	June 28 2017
19	D.C. Power Supply	Instek	PS-3030	GTS232	June 29 2016	June 28 2017
20	Splitter	Agilent	11636B	GTS237	June 29 2016	June 28 2017
21	Power meter	Anritsu	ML2495A	GTS540	June 29 2016	June 28 2017
22	Power Sensor	Anritsu	MA2411B	GTS541	June 29 2016	June 28 2017
23	Spectrum Analyzer	Agilent	E4440A	GTS533	June 29 2016	June 28 2017
24	Temp.&Humidity chamber	Chuang wei	GDS-225	GTS005-1	June 29 2016	June 28 2017
25	Highpass filter	Micro-Tronics	HPM50108	GTS549	June 29 2016	June 28 2017
26	Highpass filter	Micro-Tronics	HPM50111	GTS550	June 29 2016	June 28 2017

7 Test results

7.1 Conducted Peak Output Power

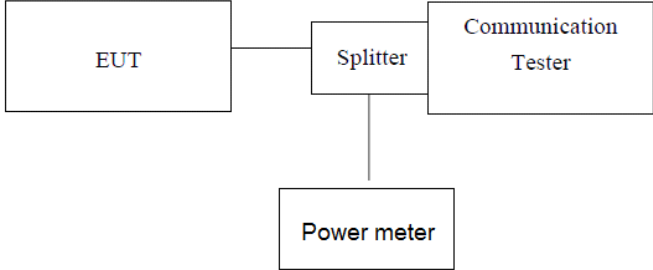
Test Requirement:	FCC part22.913(a) and FCC part24.232(b)
Test Method:	FCC part2.1046
Limit:	GSM850, WCDMA Band V: 7W PCS1900, WCDMA Band II: 2W
Test setup:	 <p style="text-align: center;"><i>Note: Measurement setup for testing on Antenna connector</i></p>
Test Procedure:	<ol style="list-style-type: none"> 1. The transmitter output port was connected to base station. 2. The RF output of EUT was connected to the power meter by RF cable and attenuator, the path loss was compensated to the results for each measurement. 3. Set EUT at maximum power through base station. 4. Select lowest, middle, and highest channels for each band and different modulation. 5. Measure the maximum burst average power.
Test Instruments:	Refer to section 6.0 for details
Test mode:	Normal link
Test results:	Pass

Measurement Data

Conducted Power (dBm)						
Band	GSM850			PCS1900		
Channel	128	190	251	512	661	810
Frequency	824.20	836.60	848.80	1850.20	1880.00	1909.80
GPRS (GMSK, 1 TX slot)	32.17	32.27	32.33	27.49	27.97	28.45
GPRS (GMSK, 2 TX slot)	30.14	30.23	30.33	25.53	25.99	26.41
GPRS (GMSK, 3 TX slot)	29.06	29.15	29.23	24.46	24.93	25.37
GPRS (GMSK, 4 TX slot)	27.63	27.74	27.81	22.99	23.44	23.87
EGPRS (8PSK, 1 TX slot)	26.23	26.14	26.17	23.96	24.27	24.67
EGPRS (8PSK, 2 TX slot)	23.92	23.77	23.87	21.91	22.17	22.38
EGPRS (8PSK, 3 TX slot)	19.10	19.43	19.74	20.69	20.96	21.30
EGPRS (8PSK, 4 TX slot)	18.60	18.97	18.66	19.44	19.58	19.80

Conducted Power (dBm)						
Band	WCDMA Band II			WCDMA Band V		
Channel	9262	9400	9538	4132	4183	4233
Frequency	1852.4	1880.0	1907.6	826.4	836.6	846.6
RMC 12.2Kbps	23.22	23.24	23.52	23.47	23.85	23.44
HSDPA Subtest-1	22.14	22.11	22.24	22.10	22.42	22.32
HSDPA Subtest-2	22.13	22.08	22.04	22.25	22.15	22.21
HSDPA Subtest-3	21.98	21.89	21.96	22.08	22.03	21.89
HSDPA Subtest-4	21.45	21.58	21.55	21.99	21.98	21.56
HSUPA Subtest-1	22.43	22.46	22.14	22.44	22.41	22.34
HSUPA Subtest-2	22.31	22.33	22.06	22.36	22.33	22.14
HSUPA Subtest-3	22.10	22.15	21.58	22.21	22.21	21.78
HSUPA Subtest-4	21.88	21.89	21.24	22.14	22.08	21.55
HSUPA Subtest-5	21.56	21.66	21.15	22.05	21.89	21.07

7.2 Peak-to-Average Ratio

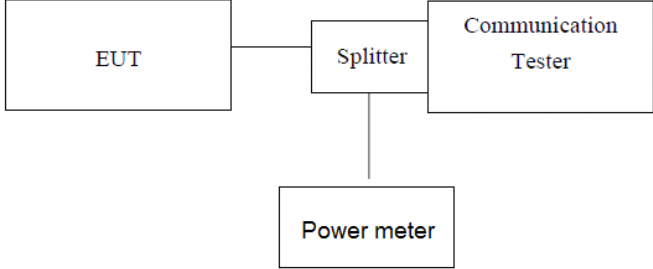
Test Requirement:	FCC part24.232(d)
Test Method:	FCC part2.1046
Limit:	13db
Test setup:	 <p><i>Note: Measurement setup for testing on Antenna connector</i></p>
Test Procedure:	<ol style="list-style-type: none"> 1. The transmitter output port was connected to base station. 2. The RF output of EUT was connected to the power meter by RF cable and attenuator, the path loss was compensated to the results for each measurement. 3. Set EUT at maximum power through base station. 4. Select lowest, middle, and highest channels for each band and different modulation. 5. Measure the maximum burst average power. 6. Record the maximum peak-to-average ratio value.
Test Instruments:	Refer to section 6.0 for details
Test mode:	Normal link
Test results:	Pass

Cellular Band						
Modes	GSM850			GSM1900		
Channel	128 (Low)	190 (Mid)	251 (High)	512 (Low)	661 (Mid)	810 (High)
Frequency(MHz)	824.2	836.6	848.8	1850.2	1880	1909.8
Peak-to-Average Ratio (dB)	0.35	0.24	0.23	0.28	0.25	0.01
Cellular Band						
Modes	WCDMA Band II (RMC 12.2Kbps)			WCDMA Band V (RMC 12.2Kbps)		
Channel	9262 (Low)	9400 (Mid)	9538 (High)	4132 (Low)	4175 (Mid)	4233 (High)
Frequency(MHz)	1852.4	1880	1907.6	826.4	836.6	846.6
Peak-to-Average Ratio (dB)	4.58	4.34	4.48	4.21	4.20	4.06

7.3 Occupancy Bandwidth

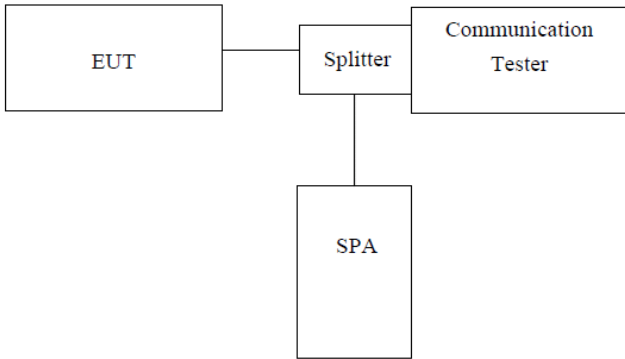
Test Requirement:	FCC part22.913(a) and FCC part24.232(b)
Test Method:	FCC part2.1049
Test setup:	 <p style="text-align: center;"><i>Note: Measurement setup for testing on Antenna connector</i></p>
Test Procedure:	<ol style="list-style-type: none"> 1. The EUT's output RF connector was connected with a short cable to the spectrum analyzer 2. RBW was set to about 1% of emission BW, VBW= 3 times RBW. 3. -26dBc display line was placed on the screen (or 99% bandwidth), the occupied bandwidth is the delta frequency between the two points where the display line intersects the signal trace.
Test Instruments:	Refer to section 6.0 for details
Test mode:	Normal link
Test results:	Pass

Measurement Data

EUT Mode	Channel	Frequency (MHz)	99% Occupy bandwidth (KHz)	-26dB bandwidth (KHz)
GSM 850 (GPRS 1 link)	128	824.20	239.960	313.999
	190	836.60	247.220	314.019
	251	848.80	245.346	315.311
GSM 850 (EGPRS 1 link)	128	824.20	241.397	318.022
	190	836.60	236.711	301.477
	251	848.80	244.627	322.424
PCS 1900 (GPRS 1 link)	512	1850.20	240.173	312.107
	661	1880.00	235.353	312.117
	810	1909.80	240.177	318.216
PCS 1900 (EGPRS 1 link)	512	1850.20	244.158	330.805
	661	1880.00	263.920	332.949
	810	1909.80	257.207	352.001
WCDMA Band V (RMC 12.2Kbps link)	4132	826.40	4206.100	4793.000
	4183	836.60	4170.400	4753.000
	4233	846.60	4173.100	4761.000
WCDMA Band II (RMC 12.2Kbps link)	9262	1852.4	4333.100	4825.000
	9400	1880.0	4309.800	4816.000
	9538	1907.6	4329.100	4819.000

Test plot as follows:

Test band: GSM 850 (GPRS 1 link)

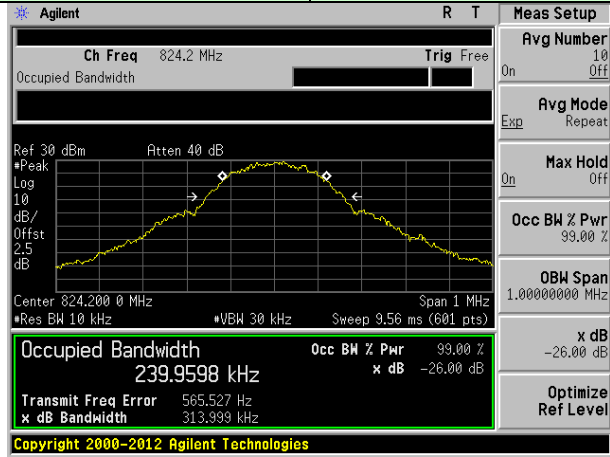

Lowest channel

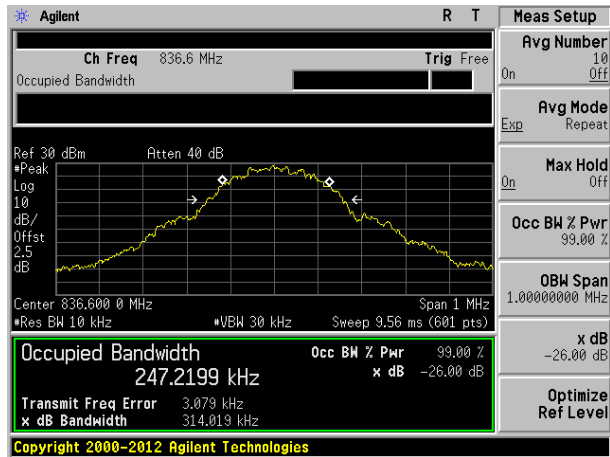

Middle channel

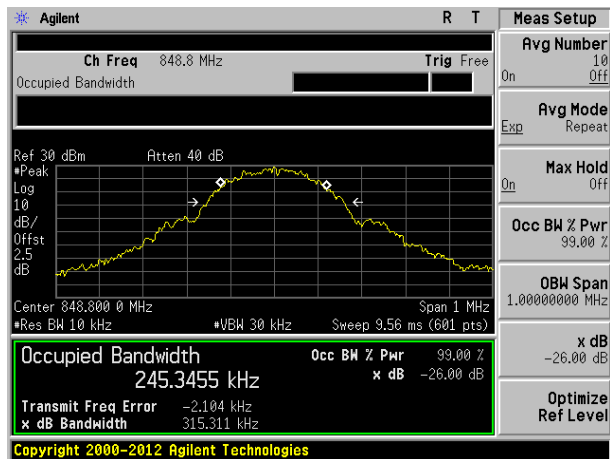

Highest channel

Test band: GSM 850 (EGPRS 1 link)



Lowest channel

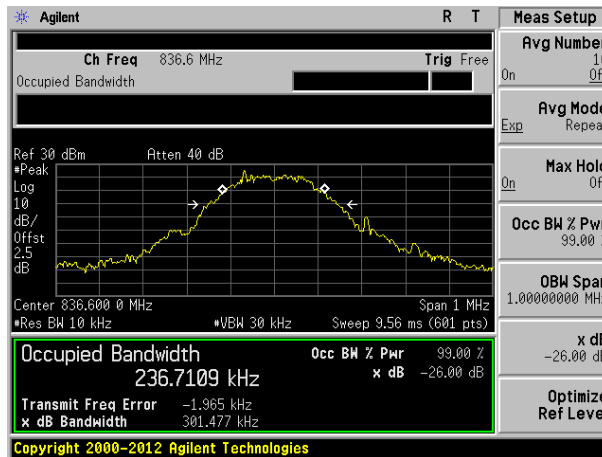

Middle channel

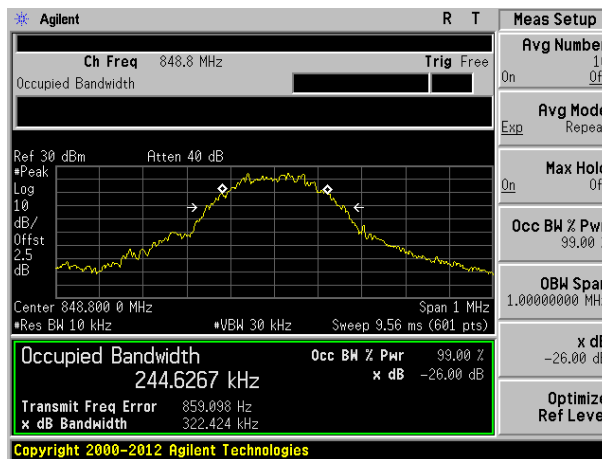

Highest channel

Test band: PCS 1900 (GPRS 1 link)



Lowest channel

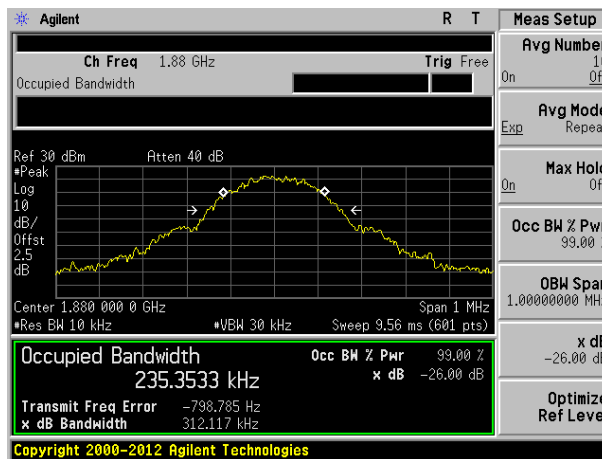

Middle channel

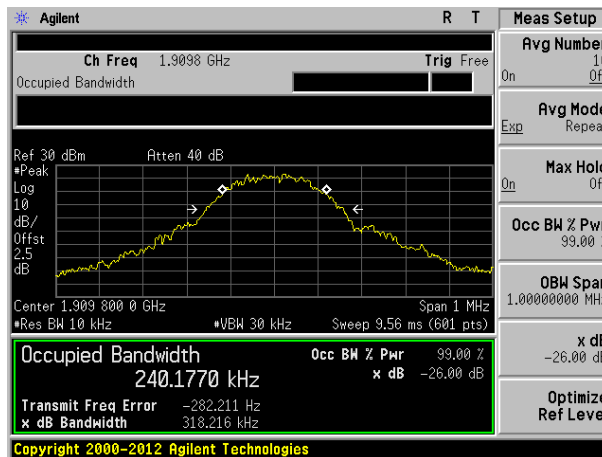

Highest channel

Test band: PCS 1900 (EGPRS 1 link)

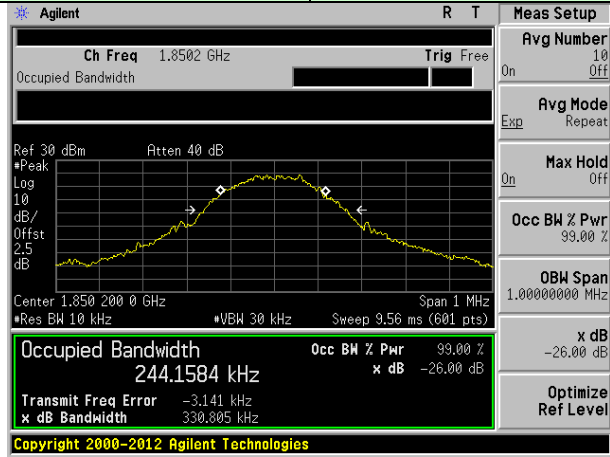

Lowest channel

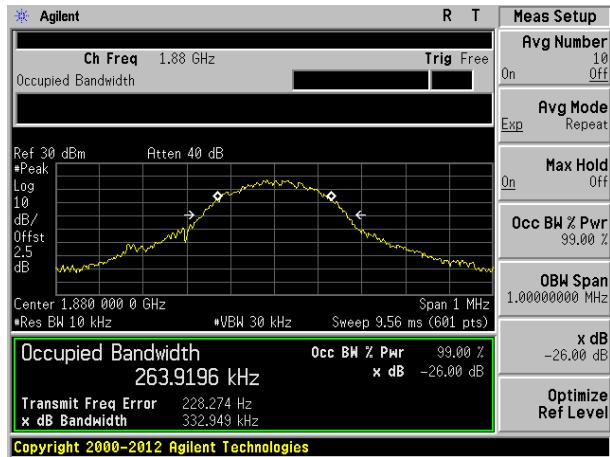

Middle channel

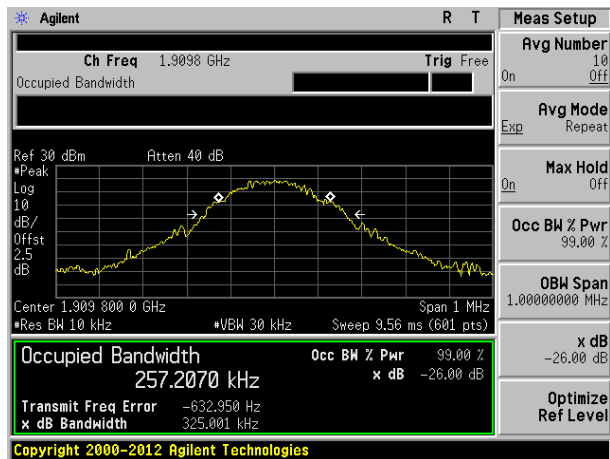

Highest channel

Test band: WCDMA Band V (RMC 12.2Kbps link)

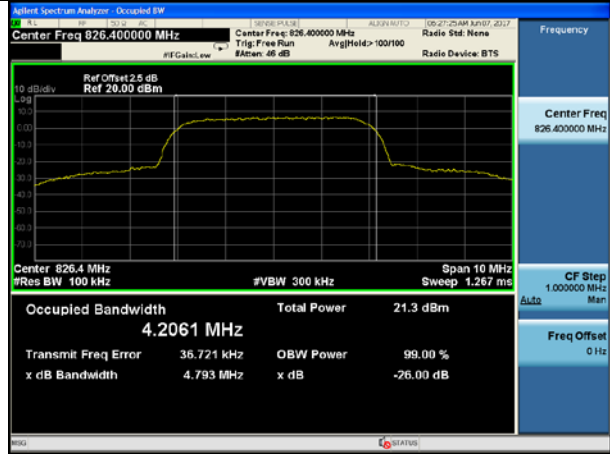

Lowest channel

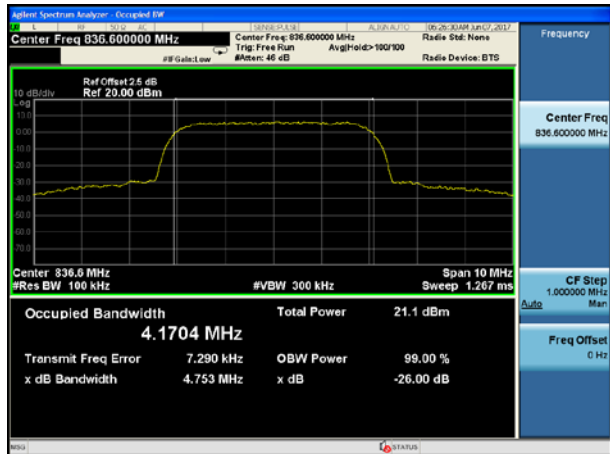

Middle channel

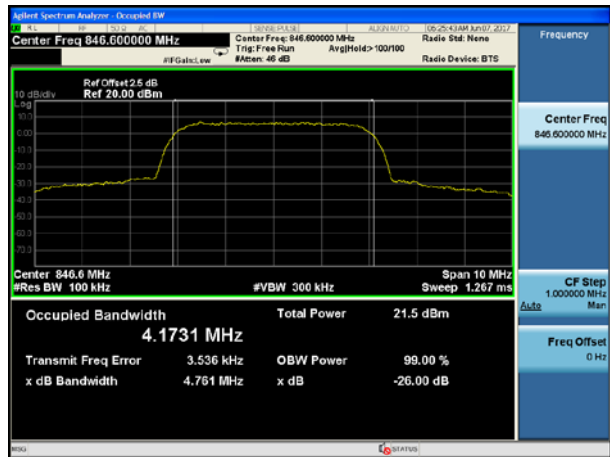

Highest channel

Test band: WCDMA Band II (RMC 12.2Kbps link)

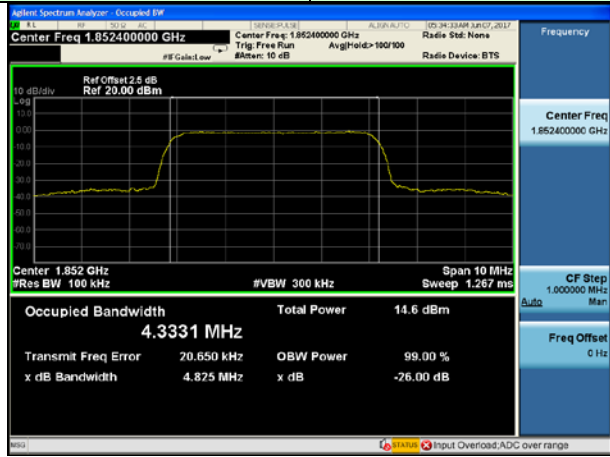

Lowest channel

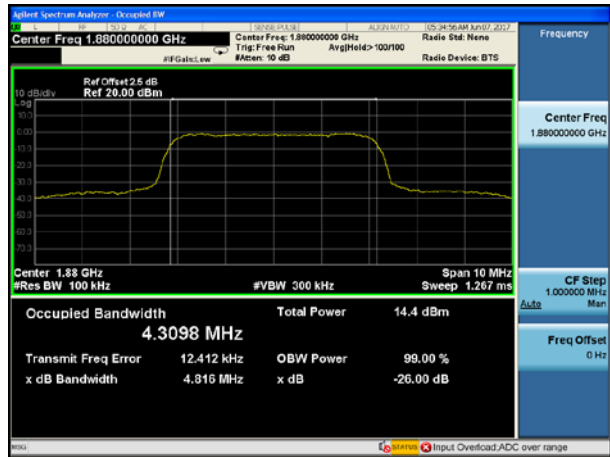

Middle channel

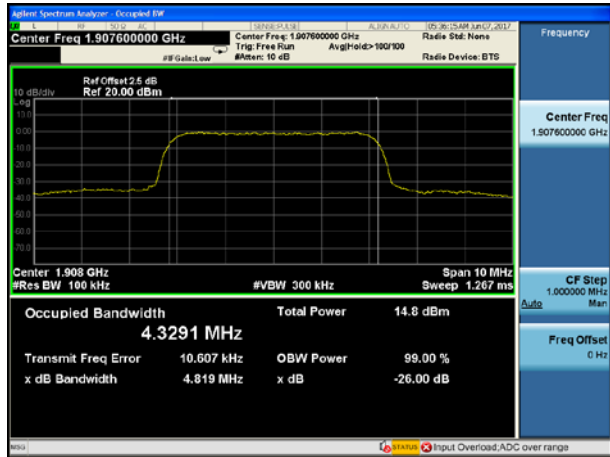

Highest channel

7.4 MODULATION CHARACTERISTIC

According to FCC § 2.1047(d), Part 22H & 24E there is no specific requirement for digital modulation, therefore modulation characteristic is not presented.

7.5 Out of band emission at antenna terminals

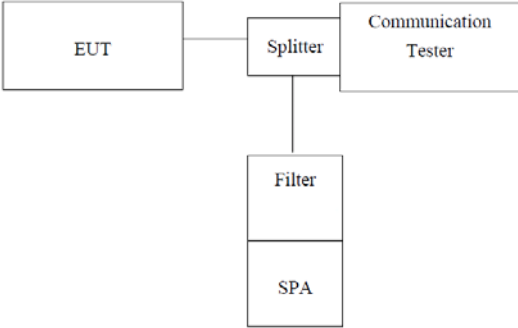
Test Requirement:	FCC part22.917(a) and FCC part24.238(a)
Test Method:	FCC part2.1051
Limit:	-13dBm
Test setup:	 <p><i>Note: Measurement setup for testing on Antenna connector</i></p>
Test Procedure:	<ol style="list-style-type: none"> 1 The RF output of the transceiver was connected to a spectrum analyzer through appropriate attenuation. 2 The resolution bandwidth of the spectrum analyzer was set at 1MHz, sufficient scans were taken to show the out of band Emissions if any up to 10th harmonic. 3 For the out of band: Set the RBW, VBW = 1MHz, Start=30MHz, Stop= 10th harmonic. 4 Band Edge Requirements: In the 1 MHz bands immediately outside and adjacent to the frequency block, a resolution bandwidth of at least 1 percent of the emission bandwidth of the fundamental emission of the transmitter may be employed to measure the out of band Emissions.
Test Instruments:	Refer to section 6.0 for details
Test mode:	Normal link
Test results:	Pass

Test plot as follows:

Note: During the conducted spurious emission test, a band filter was used. The information of the filter is reported at section 6.0 (refer to item 24, 25).

Test Mode: Traffic mode GSM 850 (GPRS 1 link)

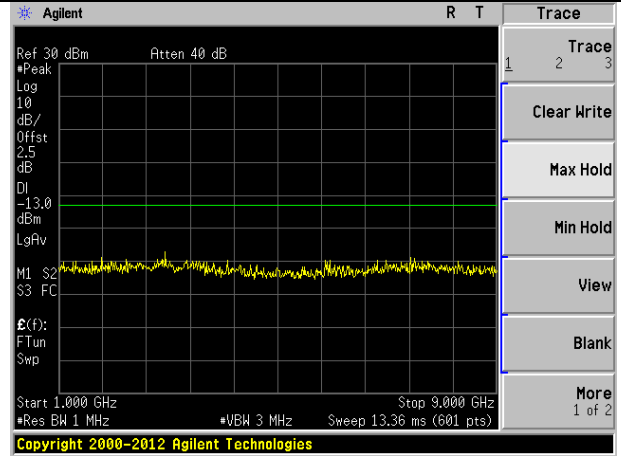
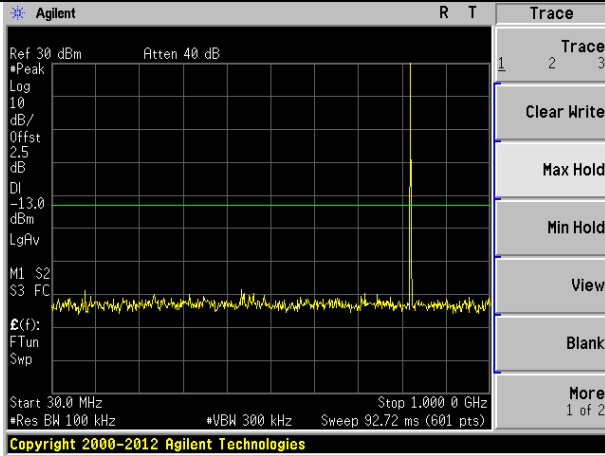

Lowest channel

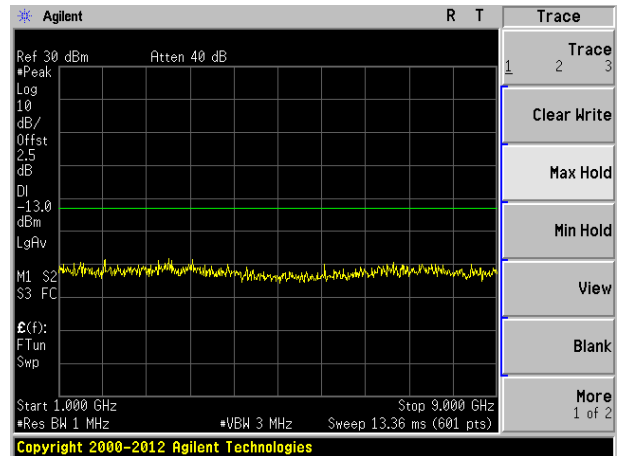
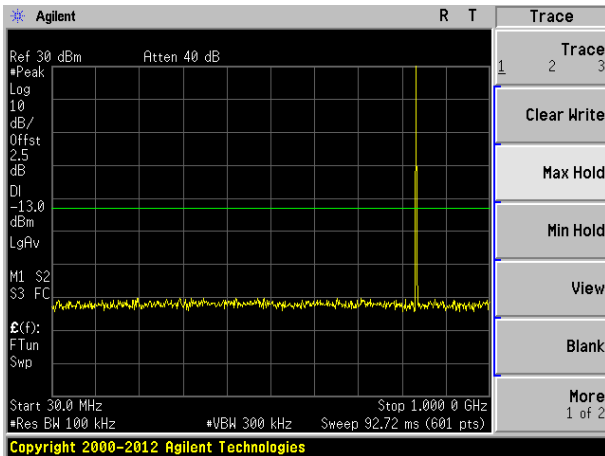

Middle channel

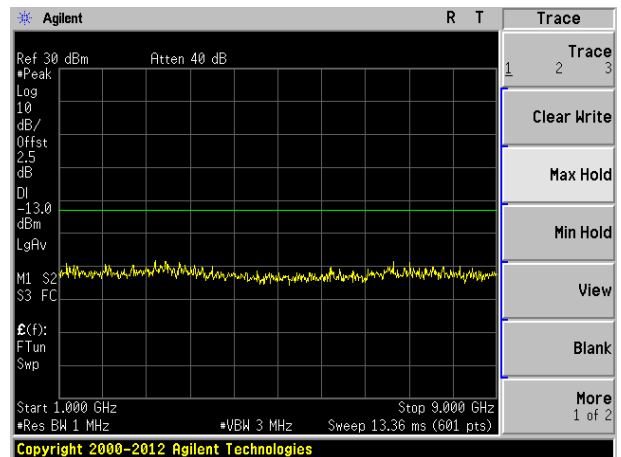
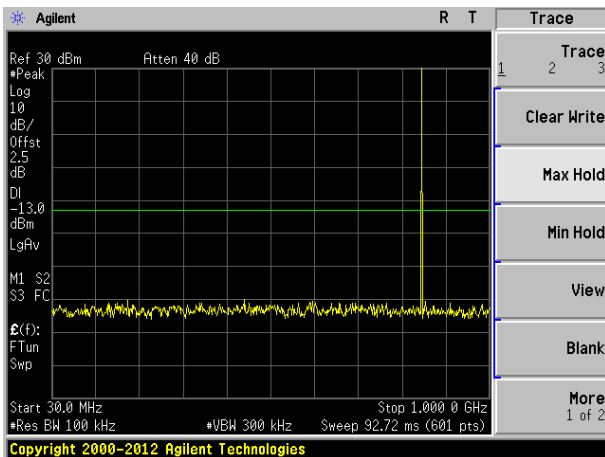

Highest channel

Test Mode: Traffic mode GSM 850 (EGPRS 1 link)

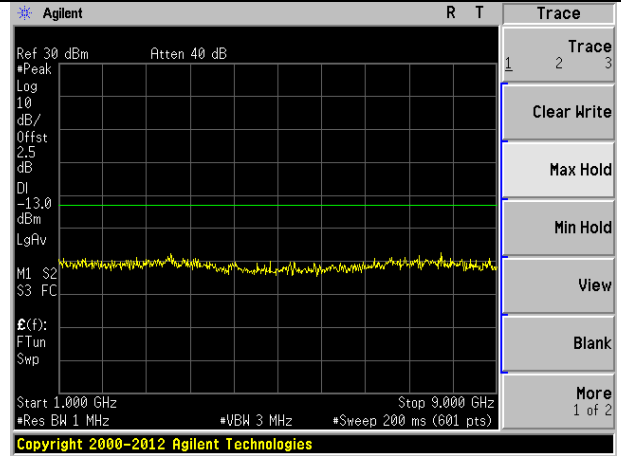
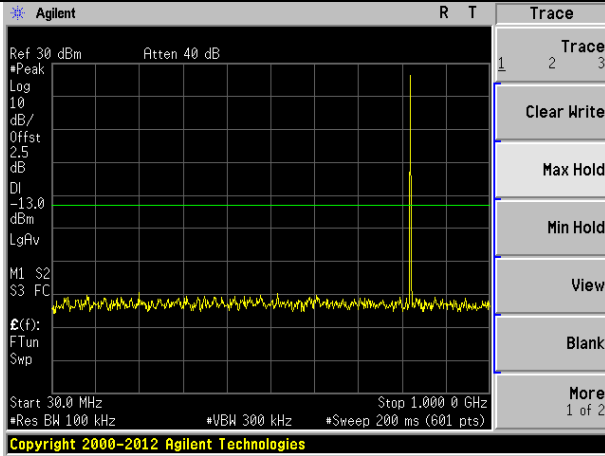

Lowest channel

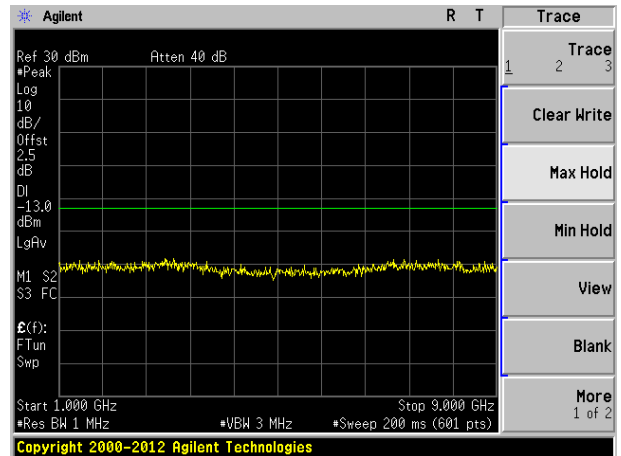
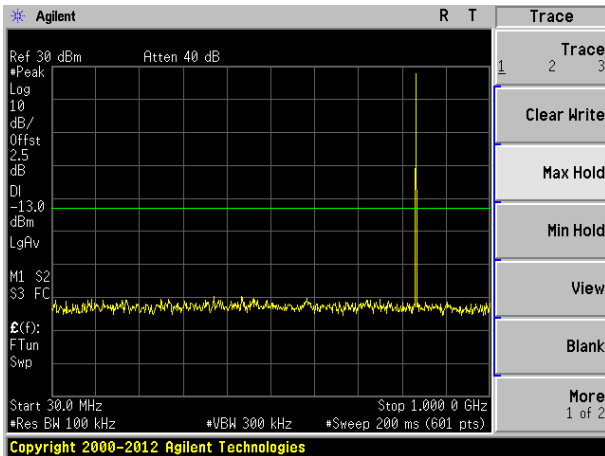

Middle channel

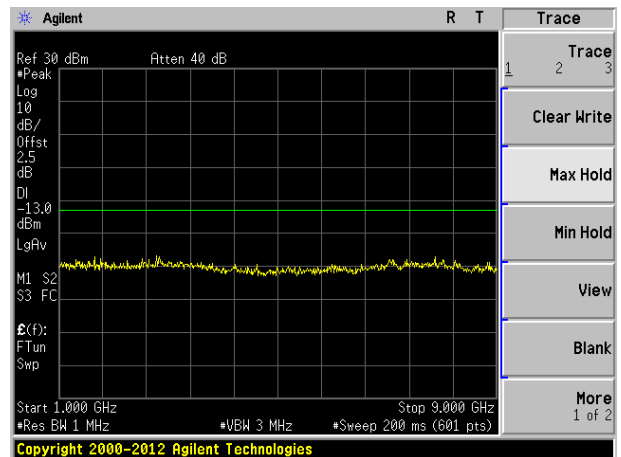
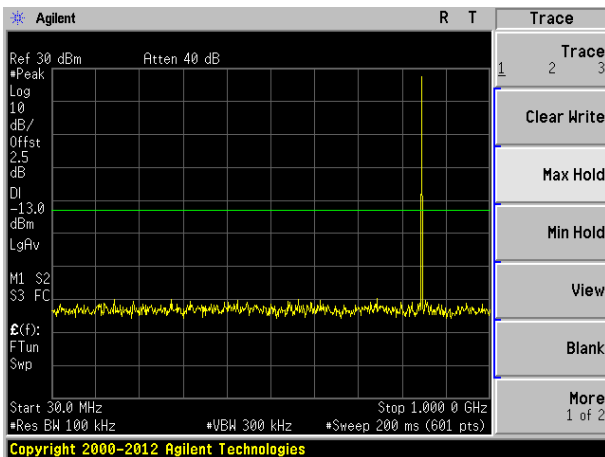

Highest channel

Test Mode: Traffic mode PCS1900 (GPRS 1 link)

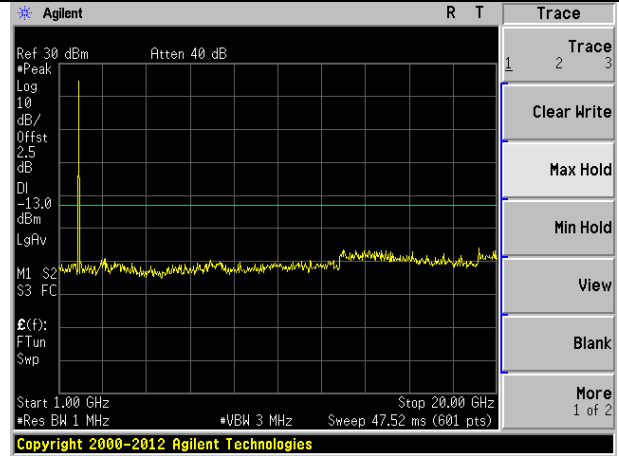
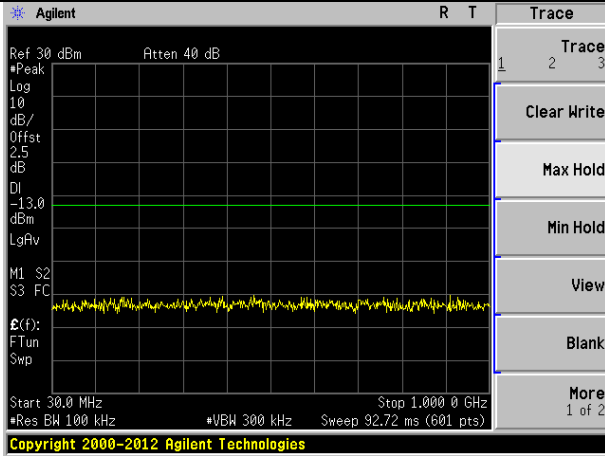

Lowest channel

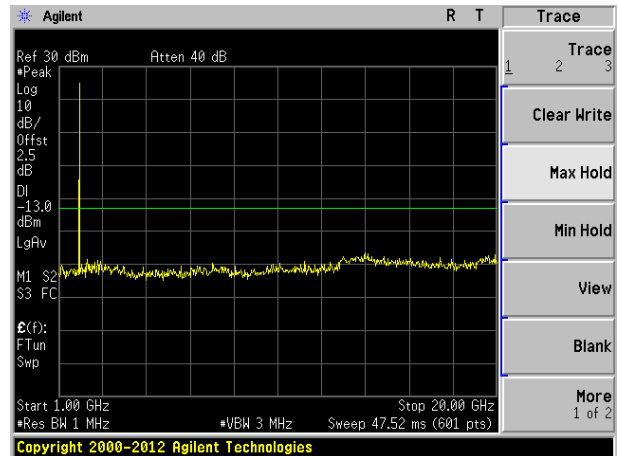
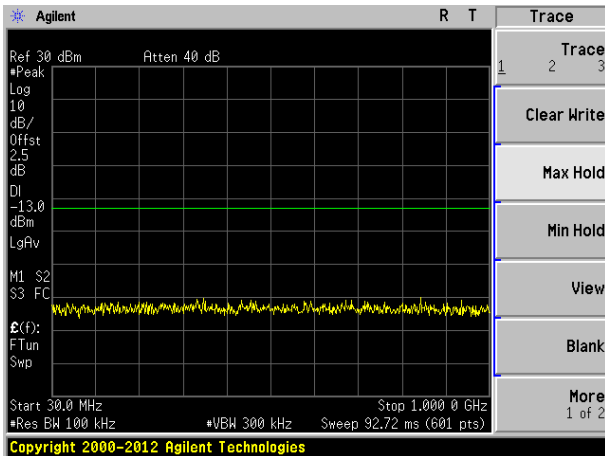

Middle channel

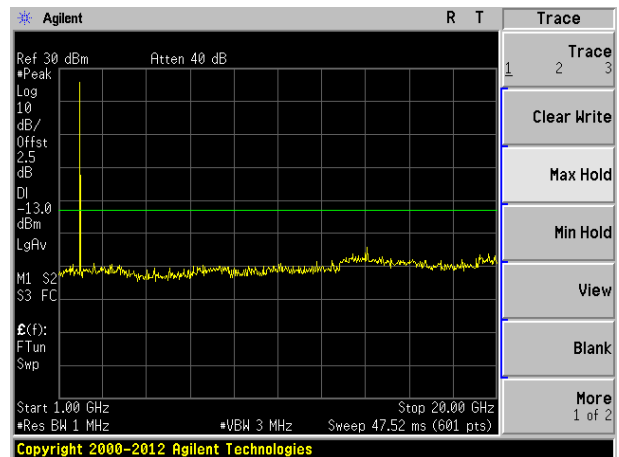
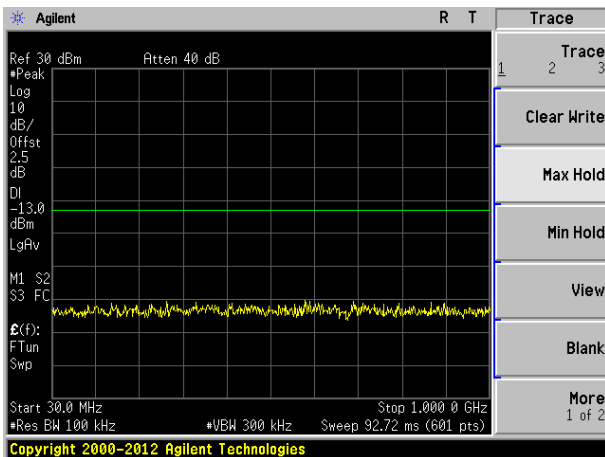

Highest channel

Test Mode: Traffic mode PCS1900 (EGPRS 1 link)

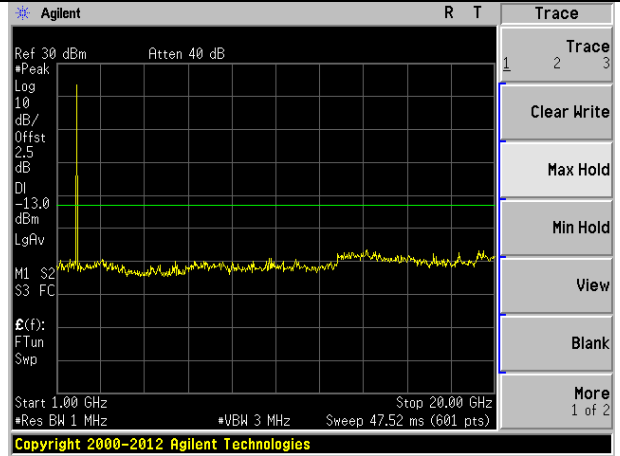
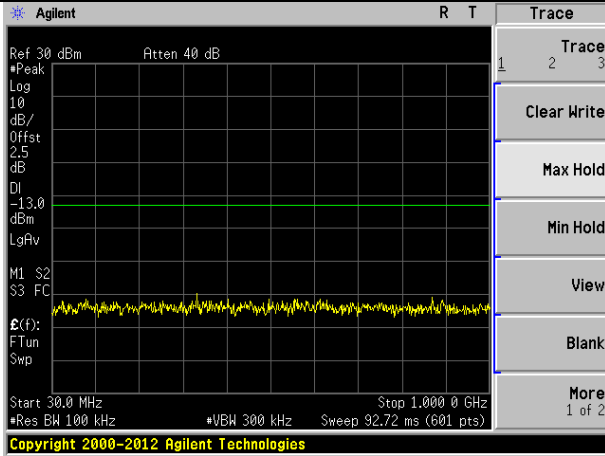

Lowest channel

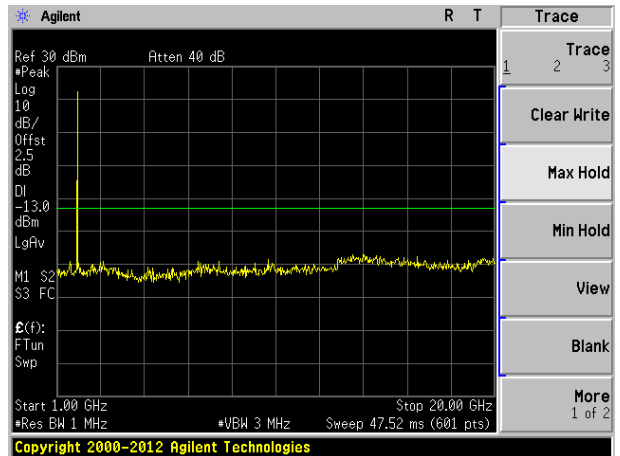
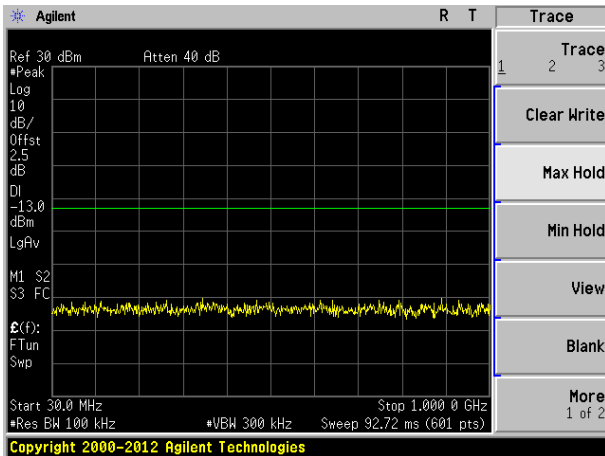

Middle channel

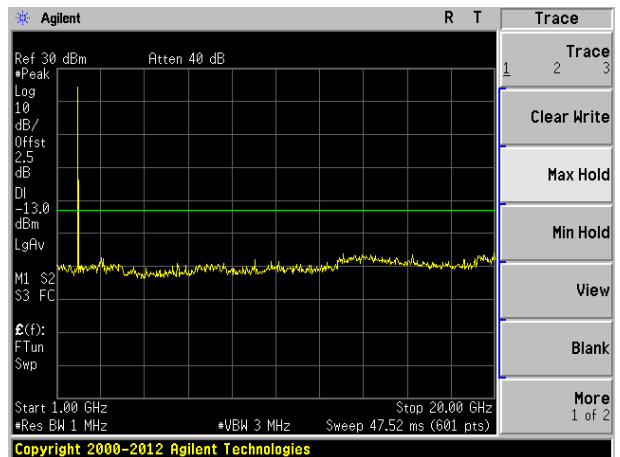
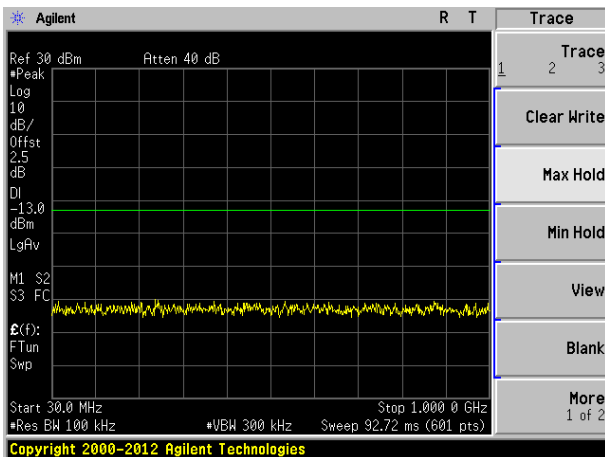

Highest channel

Test Mode: Traffic mode

WCDMA Band V (RMC 12.2Kbps link)

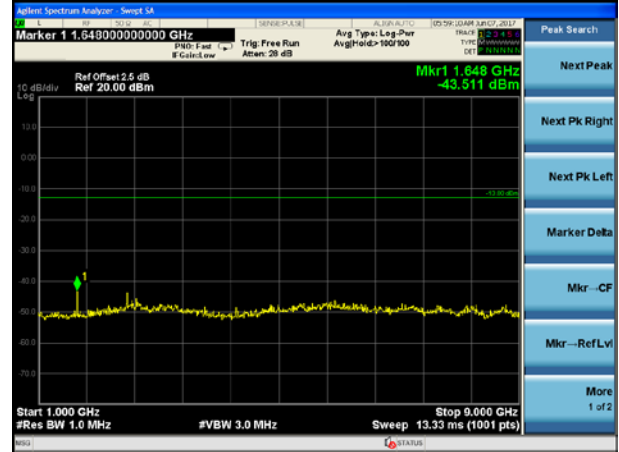
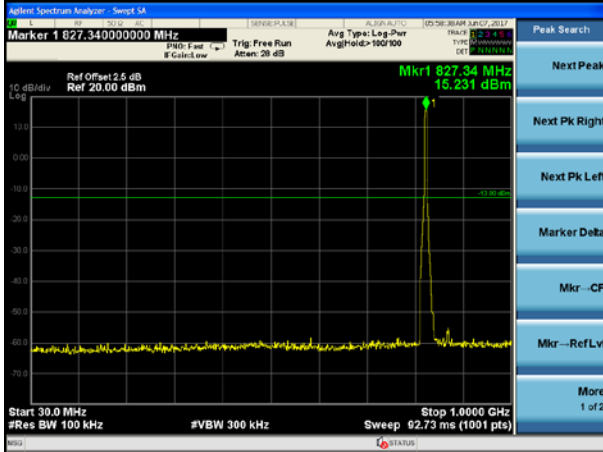

Lowest channel

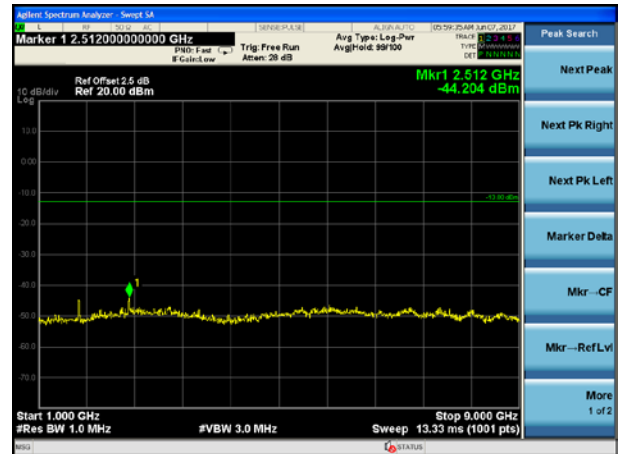
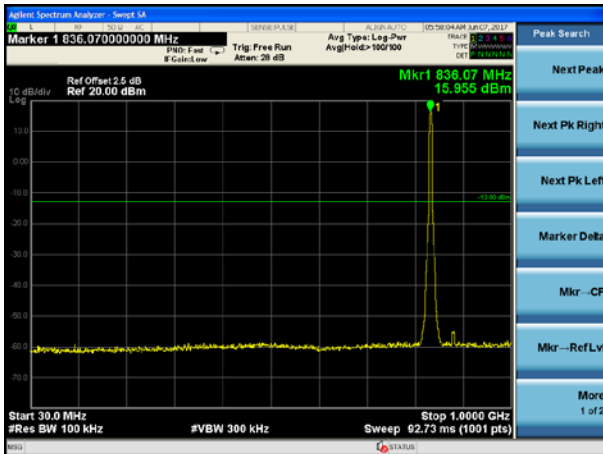

Middle channel

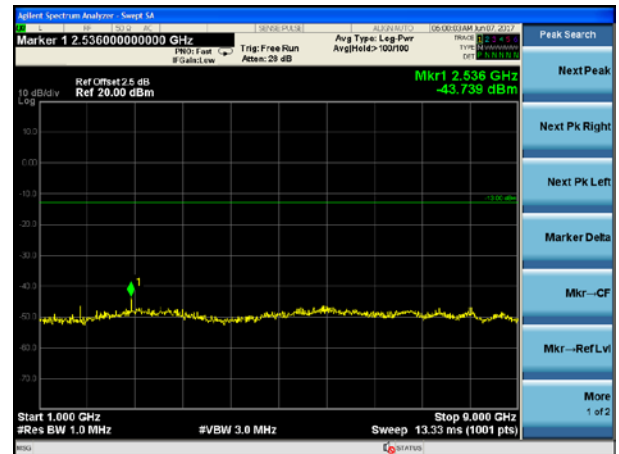
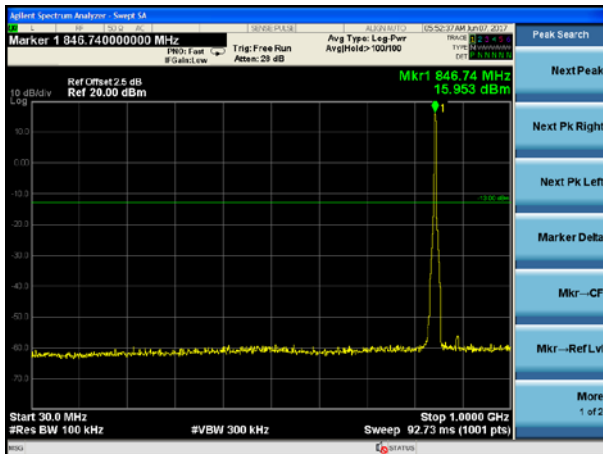

Highest channel

Test Mode: Traffic mode WCDMA Band II (RMC 12.2Kbps link)

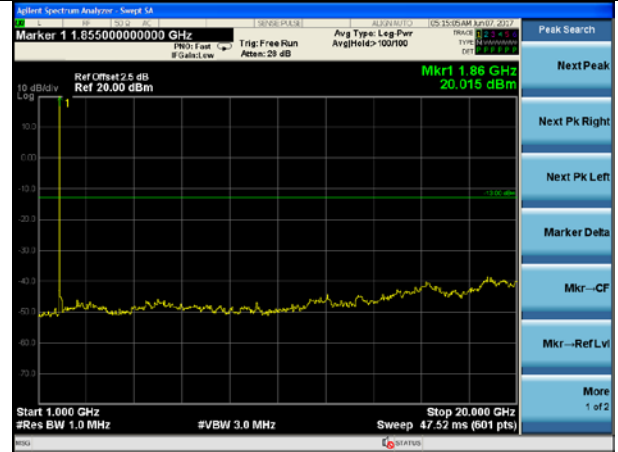
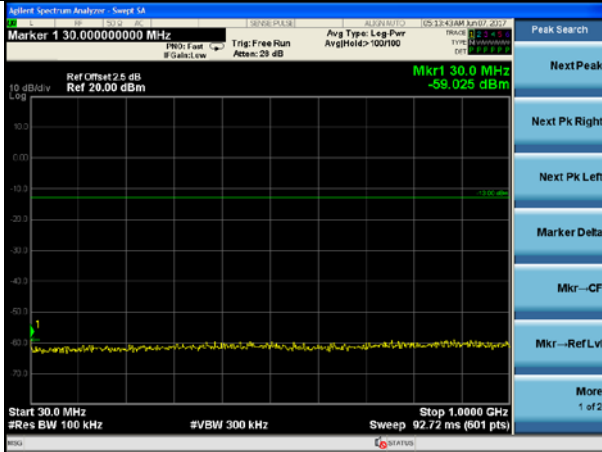

Lowest channel

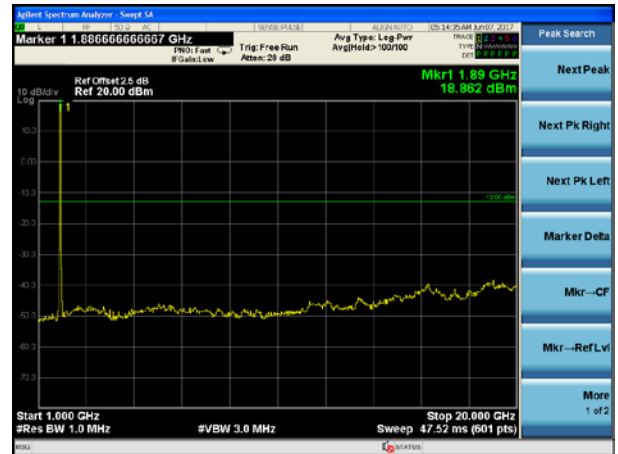
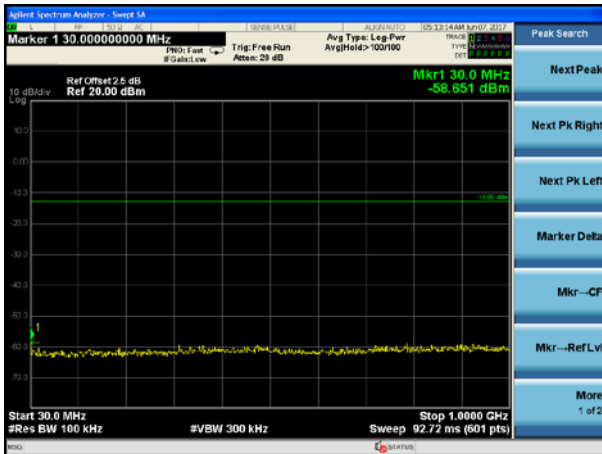

Middle channel

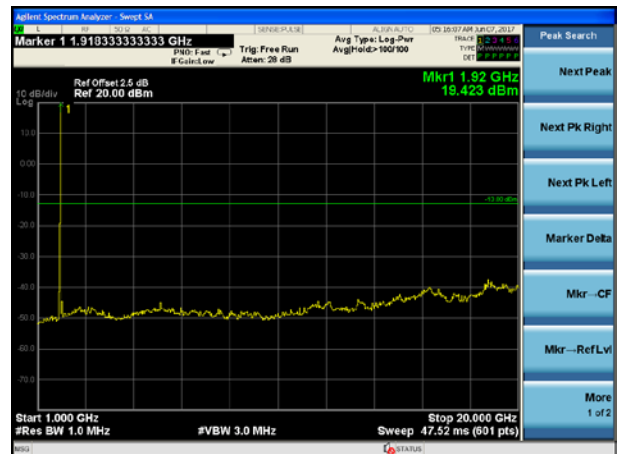
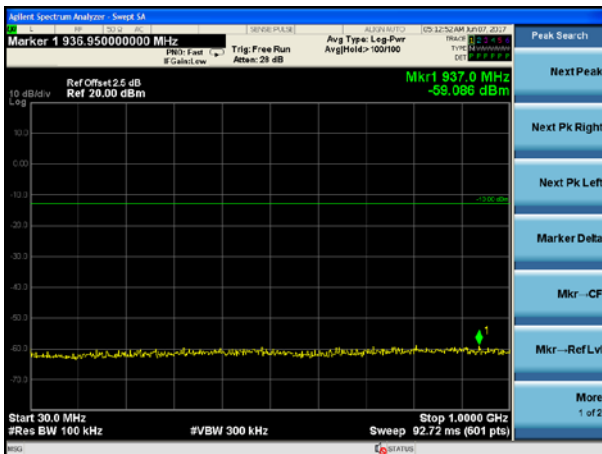

Highest channel

Band Edge:

Test Mode: Traffic mode GSM850 (GPRS 1 link)

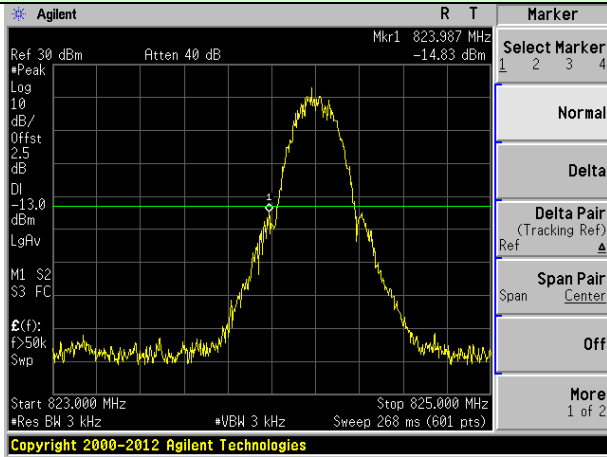

Lowest channel

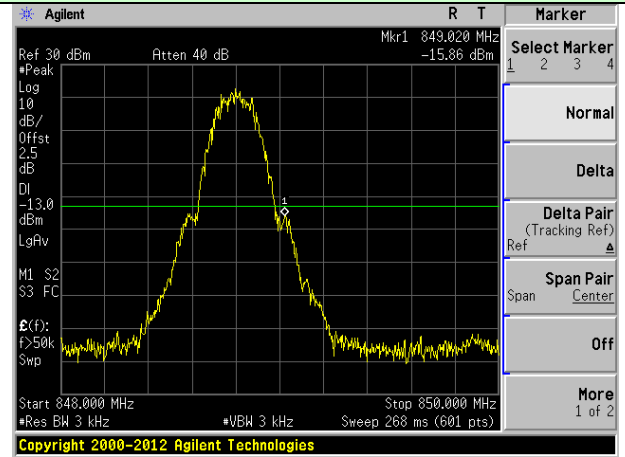

Highest channel

Test Mode: Traffic mode GSM850 (EGPRS 1 link)

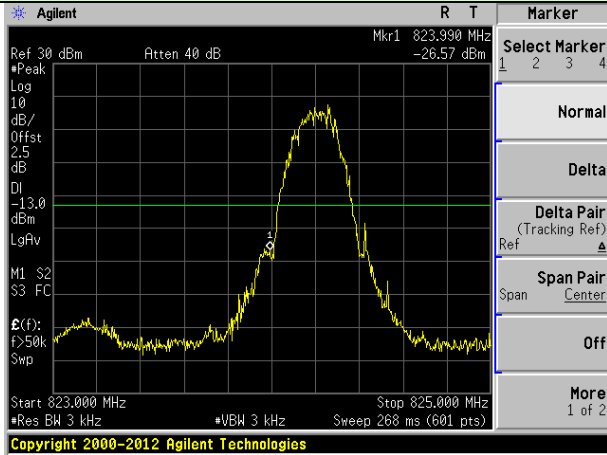

Lowest channel

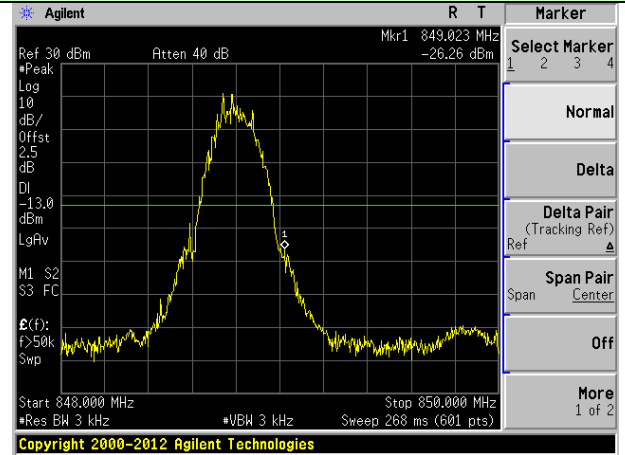

Highest channel

Test Mode: Traffic mode PCS1900 (GPRS 1 link)

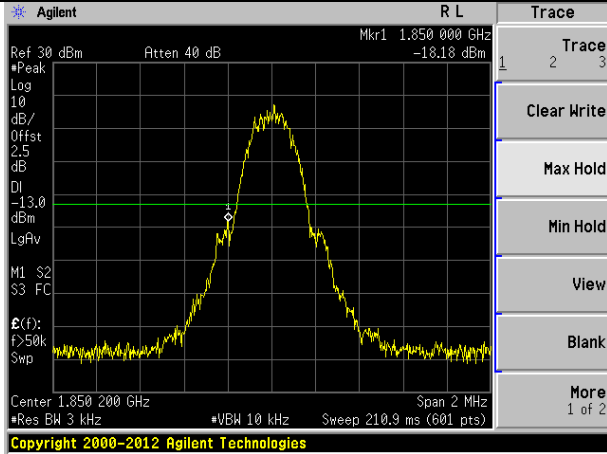

Lowest channel

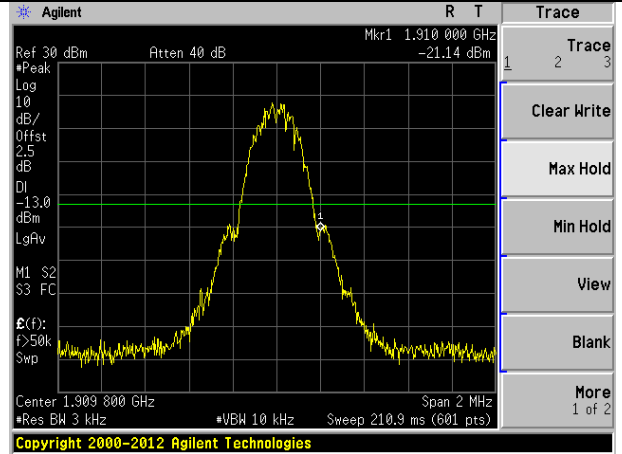

Highest channel

Test Mode: Traffic mode PCS1900 (EGPRS 1 link)

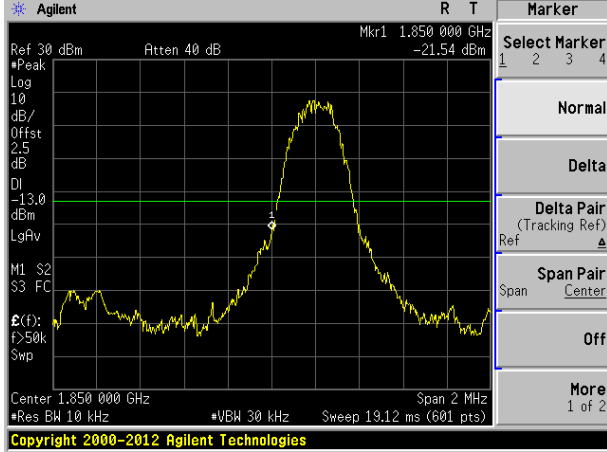

Lowest channel

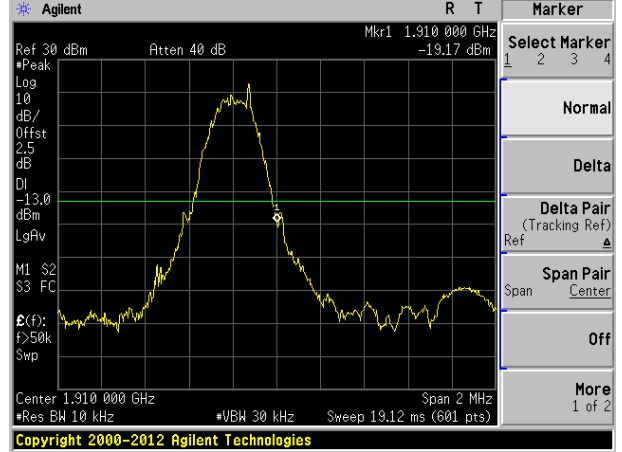

Highest channel

Test Mode: Traffic mode WCDMA Band V (RMC 12.2Kbps link)

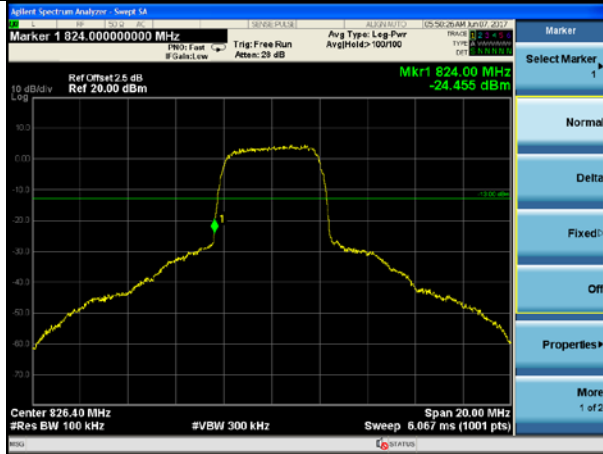

Lowest channel

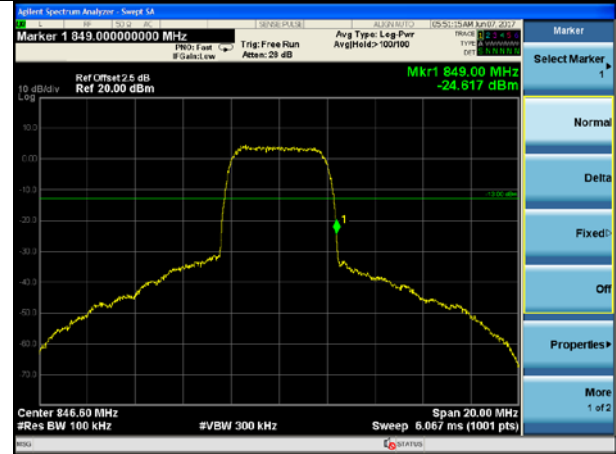

Highest channel

Test Mode: Traffic mode WCDMA Band II (RMC 12.2Kbps link)

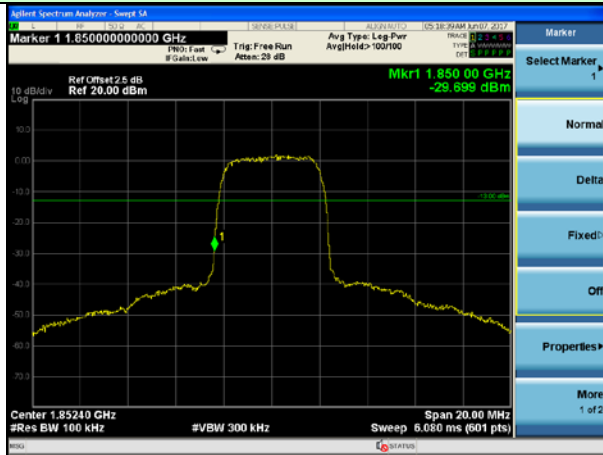

Lowest channel

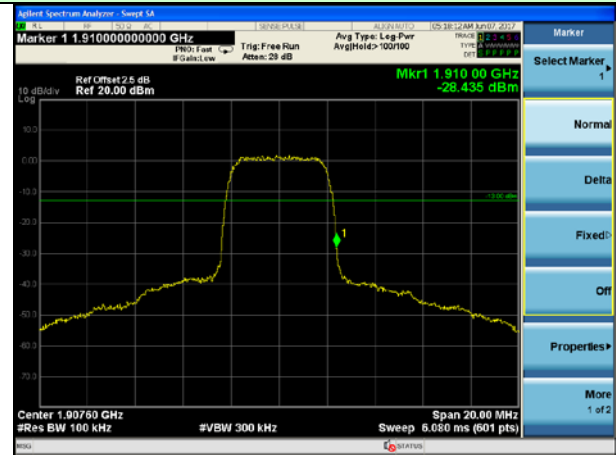

Highest channel

7.6 ERP, EIRP Measurement

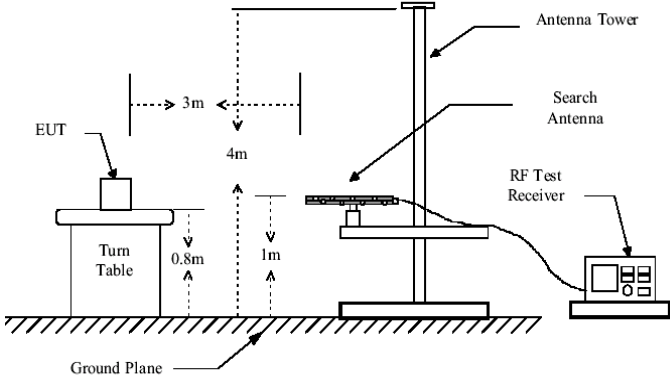
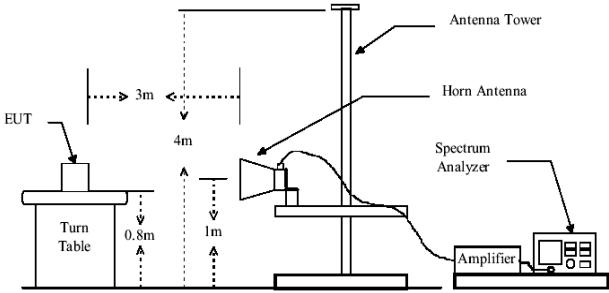
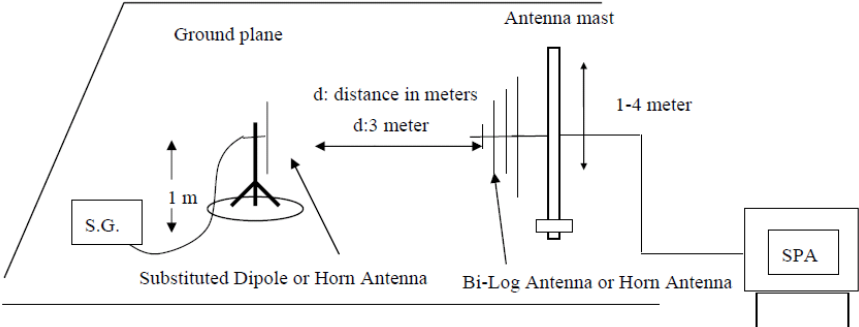
Test Requirement:	FCC part22.913(a) and FCC part24.232(b)
Test Method:	FCC part2.1046
Limit:	GSM850, WCDMA Band V: 7W ERP PCS1900, WCDMA Band II: 2W EIRP
Test setup:	<p>Below 1GHz</p>  <p>Above 1GHz</p>  <p>Substituted method:</p> 

<p>Test Procedure:</p>	<ol style="list-style-type: none"> 1. The EUT was placed on a non-conductive turntable using a non-conductive support. The radiated emission at the fundamental frequency was measured at 3 m with a test antenna and EMI spectrum analyzer. 2. During the measurement, the EUT was communication with the station. The highest emission was recorded with the rotation of the turntable and the lowering of the test antenna from 4m to 1m. The reading was recorded and the field strength (E in dBuV/m) was calculated. 3. ERP in frequency band 824.2 –848.80.8MHz were measured using a substitution method. The EUT was replaced by dipole antenna connected, the S.G. output was recorded and ERP was calculated as follows: $\text{ERP} = \text{S.G. output (dBm)} + \text{Antenna Gain (dBd)} - \text{Cable Loss (dB)}$ 4. EIRP in frequency band 1850.2 –1909.8MHz were measured using a substitution method. The EUT was replaced by or horn antenna connected, the S.G. output was recorded and EIRP was calculated as follows: $\text{EIRP} = \text{S.G. output (dBm)} + \text{Antenna Gain (dBi)} - \text{Cable Loss (dB)}$
<p>Test Instruments:</p>	<p>Refer to section 6.0 for details</p>
<p>Test mode:</p>	<p>Normal link</p>
<p>Test results:</p>	<p>Pass</p>

Measurement Data

EUT mode	Channel	EUT Pol.	Antenna Pol.	ERP(dBm)	Limit (dBm)	Result
GSM850 (GPRS 1 link)	Lowest	H	V	32.12	38.45	Pass
			H	29.02		
		E1	V	23.68		
			H	29.23		
		E2	V	22.78		
			H	26.89		
	Middle	H	V	32.07	38.45	Pass
			H	28.96		
		E1	V	23.70		
			H	29.30		
		E2	V	24.43		
			H	27.46		
	Highest	H	V	32.48	38.45	Pass
			H	28.74		
		E1	V	23.71		
			H	28.25		
		E2	V	22.64		
			H	28.04		

EUT mode	Channel	EUT Pol.	Antenna Pol.	ERP(dBm)	Limit (dBm)	Result
GSM850 (EGPRS 1 link)	Lowest	H	V	27.53	38.45	Pass
			H	24.49		
		E1	V	19.12		
			H	25.01		
		E2	V	18.50		
			H	22.90		
	Middle	H	V	27.81	38.45	Pass
			H	24.94		
		E1	V	19.71		
			H	25.64		
		E2	V	20.23		
			H	23.51		
	Highest	H	V	28.02	38.45	Pass
			H	24.31		
		E1	V	19.26		
			H	24.10		
		E2	V	20.63		
			H	23.36		

EUT mode	Channel	EUT Pol.	Antenna Pol.	EIRP (dBm)	Limit (dBm)	Result
PCS1900 (GPRS 1 link)	Lowest	H	V	28.19	33.01	Pass
			H	25.39		
		E1	V	20.58		
			H	25.54		
		E2	V	19.74		
			H	23.40		
	Middle	H	V	28.13	33.01	Pass
			H	25.29		
		E1	V	20.56		
			H	25.56		
		E2	V	21.24		
			H	23.93		
	Highest	H	V	28.60	33.01	Pass
			H	25.23		
		E1	V	20.70		
			H	24.74		
		E2	V	19.81		
			H	24.63		

EUT mode	Channel	EUT Pol.	Antenna Pol.	EIRP (dBm)	Limit (dBm)	Result
PCS1900 (EGPRS 1 link)	Lowest	H	V	23.49	33.01	Pass
			H	21.36		
		E1	V	17.79		
			H	21.19		
		E2	V	16.92		
			H	19.40		
	Middle	H	V	23.07	33.01	Pass
			H	20.74		
		E1	V	17.19		
			H	20.61		
		E2	V	17.88		
			H	19.67		
	Highest	H	V	21.98	33.01	Pass
			H	19.44		
		E1	V	16.06		
			H	18.82		
		E2	V	15.92		
			H	19.22		

EUT mode	Channel	EUT Pol.	Antenna Pol.	ERP(dBm)	Limit (dBm)	Result
WCDMA Band V	Lowest	H	V	22.96	38.45	Pass
			H	20.76		
		E1	V	17.12		
			H	20.44		
		E2	V	16.10		
			H	18.51		
	Middle	H	V	22.29	38.45	Pass
			H	19.81		
		E1	V	16.17		
			H	19.52		
		E2	V	16.96		
			H	18.68		
	Highest	H	V	21.22	38.45	Pass
			H	18.61		
		E1	V	15.16		
			H	17.85		
		E2	V	15.26		
			H	18.49		

EUT mode	Channel	EUT Pol.	Antenna Pol.	EIRP(dBm)	Limit (dBm)	Result
WCDMA Band II	Lowest	H	V	23.05	33.01	Pass
			H	20.86		
		E1	V	17.24		
			H	20.58		
		E2	V	16.25		
			H	18.67		
	Middle	H	V	22.43	33.01	Pass
			H	19.97		
		E1	V	16.35		
			H	19.71		
		E2	V	17.12		
			H	18.85		
	Highest	H	V	21.36	33.01	Pass
			H	18.76		
		E1	V	15.32		
			H	18.02		
		E2	V	15.37		
			H	18.62		

7.7 Field strength of spurious radiation measurement

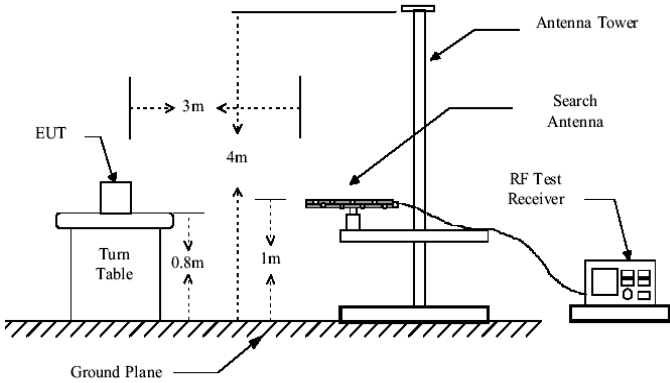
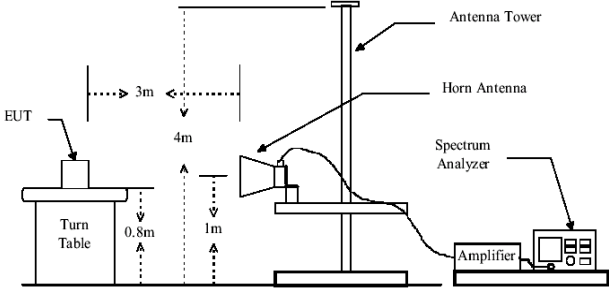
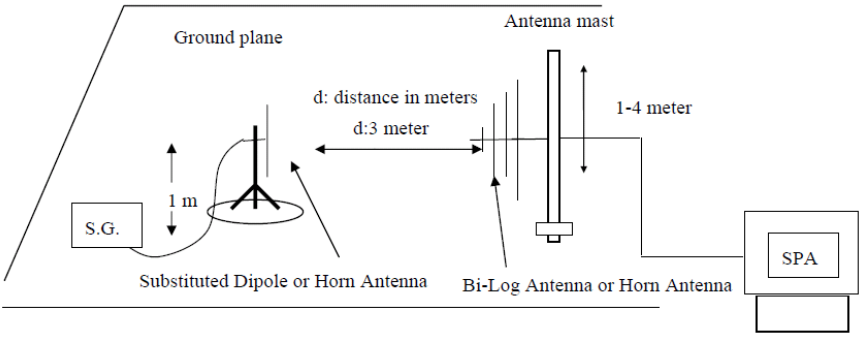
Test Requirement:	FCC part22.917(a) and FCC part24.238(a)
Test Method:	FCC part2.1053
Limit:	-13dBm
Test setup:	<p>Below 1GHz</p>  <p>Above 1GHz</p>  <p>Substituted method:</p> 

<p>Test Procedure:</p>	<ol style="list-style-type: none"> 1. The EUT was placed on a non-conductive turntable using a non-conductive support. The radiated emission at the fundamental frequency was measured at 3 m with a test antenna and EMI spectrum analyzer. 2. During the tests, the antenna height and the EUT azimuth were varied in order to identify the maximum level of emissions from the EUT. This maximization process was repeated with the EUT positioned in each of its three orthogonal orientations. 3. The frequency range up to tenth harmonic was investigated for each of three fundamental frequency (low, middle and high channels). Once spurious emission was identified, the power of the emission was determined using the substitution method. 4. The spurious emissions attenuation was calculated as the difference between radiated power at the fundamental frequency and the spurious emissions frequency. $\text{ERP / EIRP} = \text{S.G. output (dBm)} + \text{Antenna Gain(dB/dBi)} - \text{Cable Loss (dB)}$
<p>Test Instruments:</p>	<p>Refer to section 6.0 for details</p>
<p>Test mode:</p>	<p>Normal link</p>
<p>Test results:</p>	<p>Pass</p>

Measurement Data

Test mode:	GSM850		Test channel:	Lowest
Frequency (MHz)	Spurious Emission		Limit (dBm)	Result
	Polarization	Level (dBm)		
1648.40	Vertical	-35.95	-13.00	Pass
2472.60	V	-38.69		
3296.80	V	-40.95		
4121.00	V	-43.11		
4945.20	V	---		
1648.40	Horizontal	-41.19	-13.00	Pass
2472.60	H	-45.06		
3296.80	H	-46.63		
4121.00	H	-49.36		
4945.20	H	---		
Test mode:	GSM850		Test channel:	Middle
Frequency (MHz)	Spurious Emission		Limit (dBm)	Result
	Polarization	Level (dBm)		
1673.20	Vertical	-37.32	-13.00	Pass
2509.80	V	-39.59		
3346.40	V	-41.48		
4183.00	V	-43.29		
5019.60	V	---		
1673.20	Horizontal	-41.69	-13.00	Pass
2509.80	H	-44.91		
3346.40	H	-46.22		
4183.00	H	-48.50		
5019.60	H	---		
Test mode:	GSM850		Test channel:	Highest
Frequency (MHz)	Spurious Emission		Limit (dBm)	Result
	Polarization	Level (dBm)		
1697.60	Vertical	-37.55	-13.00	Pass
2546.40	V	-39.58		
3395.20	V	-41.25		
4244.00	V	-42.87		
5092.80	V	---		
1697.60	Horizontal	-41.44	-13.00	Pass
2546.40	H	-44.31		
3395.20	H	-45.47		
4244.00	H	-47.50		
5092.80	H	---		

Remark :

1. The emission behaviour belongs to narrowband spurious emission.
2. Remark"---" means that the emission level is too low to be measured
3. The emission levels of below 1 GHz are very lower than the limit and not show in test report.

Test mode:	PCS1900		Test channel:	Lowest
Frequency (MHz)	Spurious Emission		Limit (dBm)	Result
	Polarization	Level (dBm)		
3700.40	Vertical	-37.04	-13.00	Pass
5550.60	V	-39.42		
7400.80	V	-41.39		
9251.00	V	-43.29		
11101.20	V	---		
3700.40	Horizontal	-41.61	-13.00	Pass
5550.60	H	-44.99		
7400.80	H	-46.34		
9251.00	H	-48.71		
11101.20	H	---		
Test mode:	PCS1900		Test channel:	Middle
Frequency (MHz)	Spurious Emission		Limit (dBm)	Result
	Polarization	Level (dBm)		
3760.00	Vertical	-34.76	-13.00	Pass
5640.00	V	-37.22		
7520.00	V	-39.25		
9400.00	V	-41.22		
11280.00	V	---		
3760.00	Horizontal	-39.49	-13.00	Pass
5640.00	H	-42.97		
7520.00	H	-44.38		
9400.00	H	-46.84		
11280.00	H	---		
Test mode:	PCS1900		Test channel:	Highest
Frequency (MHz)	Spurious Emission		Limit (dBm)	Result
	Polarization	Level (dBm)		
3819.60	Vertical	-35.93	-13.00	Pass
5729.40	V	-38.32		
7639.20	V	-40.30		
9549.00	V	-42.19		
11458.80	V	---		
3819.60	Horizontal	-40.52	-13.00	Pass
5729.40	H	-43.90		
7639.20	H	-45.26		
9549.00	H	-47.63		
11458.80	H	---		

Remark:

1. The emission behaviour belongs to narrowband spurious emission.
2. Remark"---" means that the emission level is too low to be measured
3. The emission levels of below 1 GHz are very lower than the limit and not show in test report.

Test mode:	WCDMA Band V		Test channel:	Lowest
Frequency (MHz)	Spurious Emission		Limit (dBm)	Result
	Polarization	Level (dBm)		
1652.80	Vertical	-39.48	-13.00	Pass
2479.20	V	-40.79		
3305.60	V	-44.41		
4132.00	V	-46.87		
4958.40	V	---		
1652.80	Horizontal	-41.93	-13.00	Pass
2479.20	H	-43.83		
3305.60	H	-48.52		
4132.00	H	-50.90		
4958.40	H	---		
Test mode:	WCDMA Band V		Test channel:	Middle
Frequency (MHz)	Spurious Emission		Limit (dBm)	Result
	Polarization	Level (dBm)		
1672.80	Vertical	-37.46	-13.00	Pass
2509.20	V	-41.20		
3345.60	V	-43.94		
4182.00	V	-41.46		
5018.40	V	---		
1672.80	Horizontal	-40.26	-13.00	Pass
2509.20	H	-42.95		
3345.60	H	-48.36		
4182.00	H	-51.98		
5018.40	H	---		
Test mode:	WCDMA Band V		Test channel:	Highest
Frequency (MHz)	Spurious Emission		Limit (dBm)	Result
	Polarization	Level (dBm)		
1693.20	Vertical	-37.97	-13.00	Pass
2539.80	V	-40.40		
3386.40	V	-43.03		
4233.00	V	-45.92		
5079.60	V	---		
1693.20	Horizontal	-41.31	-13.00	Pass
2539.80	H	-43.73		
3386.40	H	-45.11		
4233.00	H	-51.29		
5079.60	H	---		

Remark :

1. The emission behaviour belongs to narrowband spurious emission.
2. Remark"---" means that the emission level is too low to be measured
3. The emission levels of below 1 GHz are very lower than the limit and not show in test report.

Test mode:	WCDMA Band II		Test channel:	Lowest
Frequency (MHz)	Spurious Emission		Limit (dBm)	Result
	Polarization	Level (dBm)		
3704.46	Vertical	-38.70	-13.00	Pass
5556.86	V	-41.79		
7409.26	V	-44.34		
9261.66	V	-46.79		
11114.40	V	---		
3704.46	Horizontal	-44.62	-13.00	Pass
5556.86	H	-48.98		
7409.26	H	-50.75		
9261.66	H	-53.82		
11114.40	H	---		
Test mode:	WCDMA Band II		Test channel:	Middle
Frequency (MHz)	Spurious Emission		Limit (dBm)	Result
	Polarization	Level (dBm)		
3759.83	Vertical	-39.48	-13.00	Pass
5639.83	V	-42.40		
7519.83	V	-44.81		
9399.83	V	-47.14		
11280.00	V	---		
3759.83	Horizontal	-45.09	-13.00	Pass
5639.83	H	-49.23		
7519.83	H	-50.90		
9399.83	H	-53.81		
11280.00	H	---		
Test mode:	WCDMA Band II		Test channel:	Highest
Frequency (MHz)	Spurious Emission		Limit (dBm)	Result
	Polarization	Level (dBm)		
3815.03	Vertical	-38.74	-13.00	Pass
5722.63	V	-41.47		
7630.23	V	-43.71		
9537.83	V	-45.89		
11445.60	V	---		
3815.03	Horizontal	-43.97	-13.00	Pass
5722.63	H	-47.83		
7630.23	H	-49.38		
9537.83	H	-52.09		
11445.60	H	---		

Remark:

1. The emission behaviour belongs to narrowband spurious emission.
2. Remark"---" means that the emission level is too low to be measured
3. The emission levels of below 1 GHz are very lower than the limit and not show in test report.

7.8 Frequency stability V.S. Temperature measurement

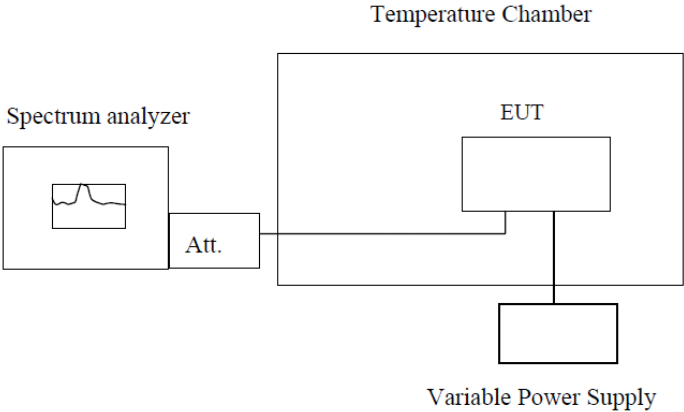
Test Requirement:	FCC Part2.1055(a)(1)(b)
Test Method:	FCC Part2.1055(a)(1)(b)
Limit:	2.5ppm
Test setup:	 <p>Note : Measurement setup for testing on Antenna connector</p>
Test procedure:	<ol style="list-style-type: none"> 1. The equipment under test was connected to an external DC power supply and input rated voltage. 2. RF output was connected to a frequency counter or spectrum analyzer via feed through attenuators. 3. The EUT was placed inside the temperature chamber. 4. Set the spectrum analyzer RBW low enough to obtain the desired frequency resolution and measure EUT 25°C operating frequency as reference frequency. 5. Turn EUT off and set the chamber temperature to -20°C. After the temperature stabilized for approximately 30 minutes recorded the frequency. 6. Repeat step measure with 10°C increased per stage until the highest temperature of +50°C reached.
Test Instruments:	Refer to section 6.0 for details
Test mode:	Normal link
Test results:	Pass

Measurement Data

Reference Frequency: GSM850 (GPRS 1 link) Middle channel=190 channel=836.6MHz					
Power supplied (Vac)	Temperature (°C)	Frequency error		Limit (ppm)	Result
		Hz	ppm		
120	-30	31	0.0371	2.5	Pass
	-20	34	0.0410		
	-10	30	0.0358		
	0	26	0.0307		
	10	29	0.0345		
	20	26	0.0307		
	30	39	0.0462		
	40	35	0.0423		
	50	34	0.0410		
Reference Frequency: GSM850 (EGPRS 1 link) Middle channel=190 channel=836.6MHz					
Power supplied (Vac)	Temperature (°C)	Frequency error		Limit (ppm)	Result
		Hz	ppm		
120	-30	30	0.0354	2.5	Pass
	-20	32	0.0383		
	-10	28	0.0340		
	0	26	0.0311		
	10	27	0.0326		
	20	25	0.0297		
	30	38	0.0454		
	40	33	0.0397		
	50	32	0.0383		

Reference Frequency: PCS1900 (GPRS 1 link) Middle channel=661 channel=1880MHz					
Power supplied (Vac)	Temperature (°C)	Frequency error			Result
		Hz	ppm		
120	-30	35	0.0187	2.5	Pass
	-20	44	0.0234		
	-10	35	0.0187		
	0	28	0.0149		
	10	35	0.0187		
	20	29	0.0156		
	30	54	0.0288		
	40	45	0.0241		
	50	42	0.0226		
Reference Frequency: PCS1900 (EGPRS 1 link) Middle channel=661 channel=1880MHz					
Power supplied (Vac)	Temperature (°C)	Frequency error			Result
		Hz	ppm		
120	-30	37	0.0197	2.5	Pass
	-20	44	0.0234		
	-10	34	0.0183		
	0	27	0.0146		
	10	36	0.0190		
	20	27	0.0146		
	30	51	0.0271		
	40	41	0.0219		
	50	44	0.0234		

Reference Frequency: WCDMA Band V Middle channel=4183 channel=836.6MHz					
Power supplied (Vac)	Temperature (°C)	Frequency error		Limit (ppm)	Result
		Hz	ppm		
120	-30	31	0.0371	2.5	Pass
	-20	43	0.0515		
	-10	48	0.0580		
	0	23	0.0280		
	10	34	0.0410		
	20	38	0.0449		
	30	55	0.0658		
	40	52	0.0619		
	50	62	0.0736		
Reference Frequency: WCDMA Band II Middle channel=9400 channel=1880.0MHz					
Power supplied (Vac)	Temperature (°C)	Frequency error		Limit (ppm)	Result
		Hz	ppm		
120	-30	102	0.0544	2.5	Pass
	-20	91	0.0483		
	-10	78	0.0415		
	0	73	0.0388		
	10	67	0.0355		
	20	58	0.0307		
	30	73	0.0388		
	40	82	0.0436		
	50	78	0.0415		

7.9 Frequency stability V.S. Voltage measurement

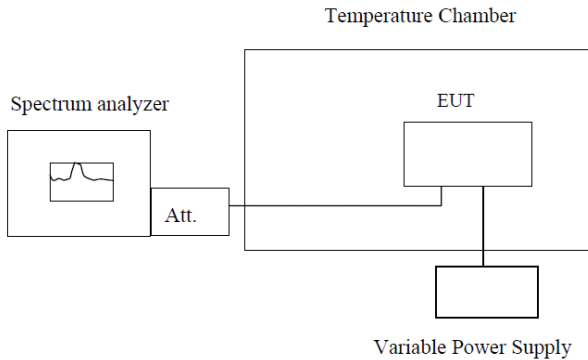
Test Requirement:	FCC Part2.1055(d)(1)(2)
Test Method:	FCC Part2.1055(d)(1)(2)
Limit:	2.5ppm
Test setup:	 <p style="text-align: center;">Temperature Chamber</p> <p style="text-align: center;">Spectrum analyzer</p> <p style="text-align: center;">Att.</p> <p style="text-align: center;">EUT</p> <p style="text-align: center;">Variable Power Supply</p> <p>Note : Measurement setup for testing on Antenna connector</p>
Test procedure:	<ol style="list-style-type: none"> 1. Set chamber temperature to 25°C. Use a variable DC power source to power the EUT and set the voltage to rated voltage. 2. Set the spectrum analyzer RBW low enough to obtain the desired frequency resolution and recorded the frequency. 3. Reduce the input voltage to specified extreme voltage variation (+/- 15%) and endpoint, record the maximum frequency change.
Test Instruments:	Refer to section 6.0 for details
Test mode:	Normal link
Test results:	Pass

Measurement Data

Reference Frequency: GSM850 (GPRS 1 link) Middle channel=190 channel=836.6MHz					
Temperature (°C)	Power supplied (Vac)	Frequency error		Limit (ppm)	Result
		Hz	ppm		
25	138	19	0.0232	2.5	Pass
	120	22	0.0260		
	102	24	0.0288		
Reference Frequency: GSM850 (EGPRS 1 link) Middle channel=190 channel=836.6MHz					
Temperature (°C)	Power supplied (Vac)	Frequency error		Limit (ppm)	Result
		Hz	ppm		
25	138	24	0.0283	2.5	Pass
	120	15	0.0183		
	102	18	0.0216		

Reference Frequency: PCS1900 (GPRS 1 link) Middle channel=661 channel=1880MHz					
Temperature (°C)	Power supplied (Vac)	Frequency error		Limit (ppm)	Result
		Hz	ppm		
25	138	31	0.0371	2.5	Pass
	120	36	0.0430		
	102	41	0.0487		
Reference Frequency: PCS1900 (EGPRS 1 link) Middle channel=661 channel=1880MHz					
Temperature (°C)	Power supplied (Vac)	Frequency error		Limit (ppm)	Result
		Hz	ppm		
25	138	20	0.0106	2.5	Pass
	120	28	0.0147		
	102	28	0.0147		

Reference Frequency: WCDMA Band V Middle channel=4183 channel=836.6MHz					
Temperature (°C)	Power supplied (Vac)	Frequency error		Limit (ppm)	Result
		Hz	ppm		
25	138	40	0.0215	2.5	Pass
	120	32	0.0171		
	102	34	0.0180		
Reference Frequency: WCDMA Band II Middle channel=940 channel=1880.0MHz					
Temperature (°C)	Power supplied (Vac)	Frequency error		Limit (ppm)	Result
		Hz	ppm		
25	138	64	0.0338	2.5	Pass
	120	72	0.0384		
	102	73	0.0386		

8 Test Setup Photo

Radiated Emission

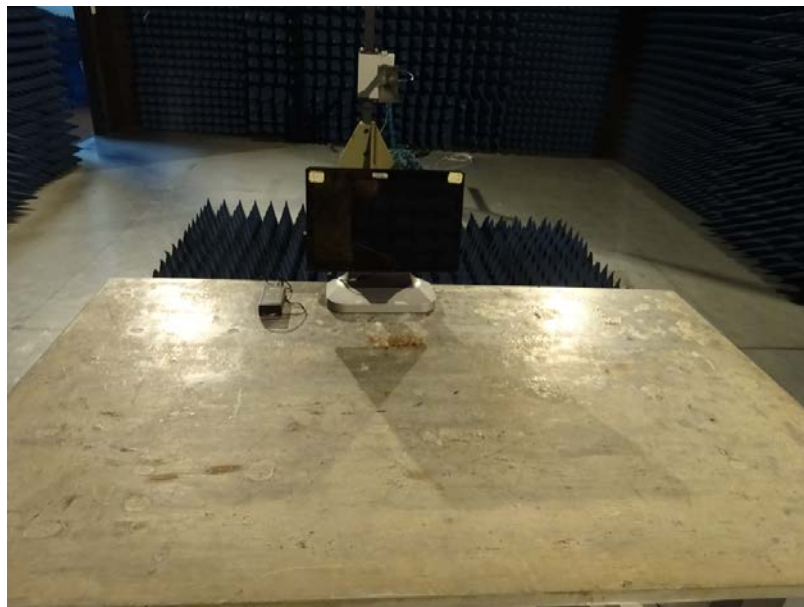

9 EUT Constructional Details

Reference to the test report No. : GTS201705000240F01

-----End-----