

# BF-IDU08

RFID-Reader

# BALLUFF

## Company Addresses

### Europe, Germany, Headquarter

Balluff GmbH  
Schurwaldstraße 9  
D-73765 Neuhausen a.d.F.

### Argentina

Balluff Argentina S.R.L.  
Av del Libertador 650 Piso 7 Sur  
B1638BES - Vicente Lopez, Buenos Aires

### Australia

Balluff Pty Ltd.  
18 Malvern Street  
Bayswater, 3153 Victoria

### Brasil

Balluff Controles Elétricos Ltda.  
Rua Francisco Foga, 25 ,Distrito Industrial  
CEP 13280.000 – Vinhedo – SP

### Canada

Balluff Canada Inc.  
2840 Argentia Road, Unit 1 Mississauga,  
Ontario L5N 8G4

### China

Balluff (Shanghai) Trading Co. Ltd.  
No.800 Chengshan Rd, 8F, Building A, Yunding International Commercial Plaza  
200125, Pudong, Shanghai

### Japan

Balluff Co., Ltd.  
Aqua Hakusan Bldg. 9F 1-13-7 Hakusan, Bunkyo-ku,  
Tokyo 113-0001

### Mexico

Balluff de México S.A. de C.V.  
Anillo Vial II Fray Junipero Serra No. 4416; Colonia La Vista Residencial  
CP 76232 Delegación Epigmenio González, Querétaro

### USA

Balluff Inc.  
8125 Holton Drive, Florence  
Kentucky 41042-0937



## Operating Guide

### Purpose of the Device

The BF-IDU08 device is intended to read and write "EPC Global Class 1 Gen2" compliant data carriers (so called tags) via country dependent UHF radio frequencies.

### Check that you have the right device variant

This UHF system consists of a radio frequency unit and an integrated antenna according to specifications and may only be operated within the specified countries subject to all applicable national legal regulations and standards.

Check that the type label contains the correct type of approval symbol for your country.

- ▶ When using the UHF system in the European Community, the provisions in ETSI standard 302 208 apply.
- ▶ When using the UHF system in the USA, the directives of the FCC, Part 15 B and 15 C, apply.
- ▶ When using the UHF system in Canada, the directives of the IC, RSS-210 apply.
- ▶ When using the UHF system in China, the directives of the RFID National Standard and GB 9254 apply.

This device complies with Part 15 of the FCC Rules. Operation is subject to the following two conditions:

- (1) This device may not cause harmful interference, and
- (2) This device must accept any interference received, including interference that may cause undesired operation.

# BF-IDU08

RFID-Reader

# BALLUFF

## Connecting the Device

The BF-IDU08 device has to be connected to one of the IO-Link-Device ports of an IO-Link-Master unit via standard 4-wire cable with M12 industry connectors (A-coded). The IO-Link-Master unit provides power supply and controls the device over its IO-Link interface connection.

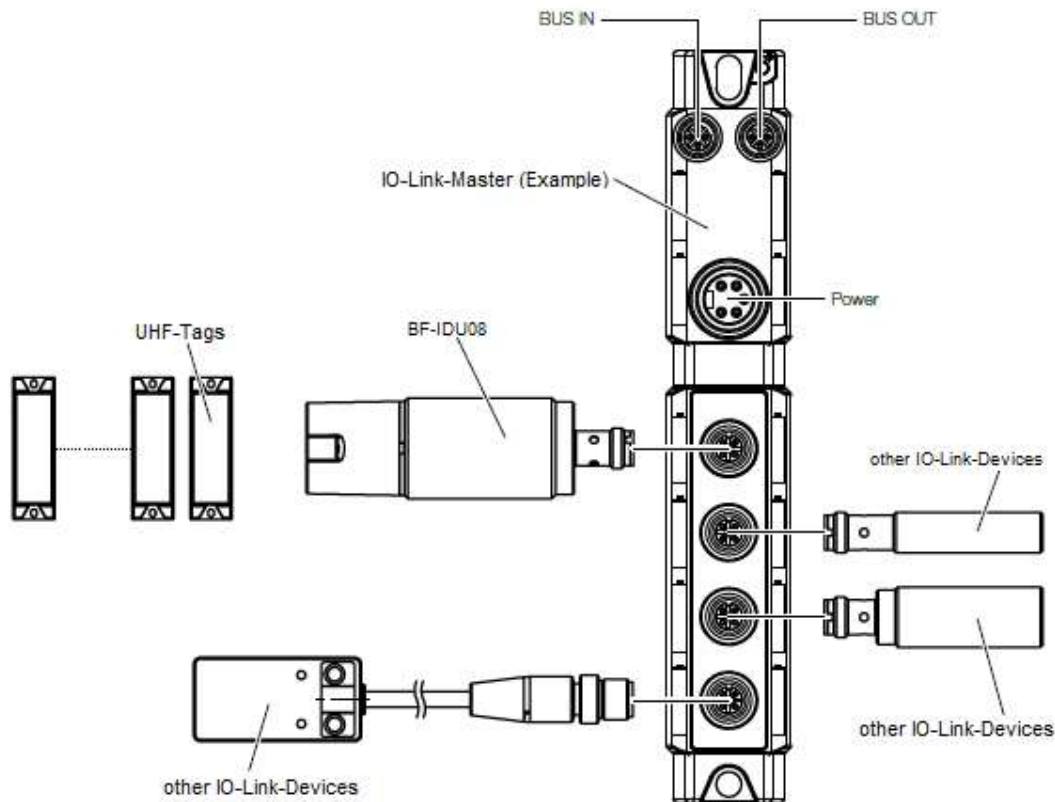

Figure 1: System overview

The IO-Link-Master unit itself needs to be connected to a power supply and the customer's PLC unit. For further information, please refer to the user manual of the used IO-Link-Master unit.

## Mounting

Before operating the device has to be mounted with the provided M30 nuts or other suitable fixtures, Figure 2. Optional mounting fixtures are available at [www.balluff.com](http://www.balluff.com). The BF-IDU08 device may be mounted in any direction, the operating direction of the integrated antenna is towards the length axis of the BF-IDU08 device as displayed in Figure 1 (direction towards the UHF-Tags).

# BF-IDU08

RFID-Reader

# BALLUFF

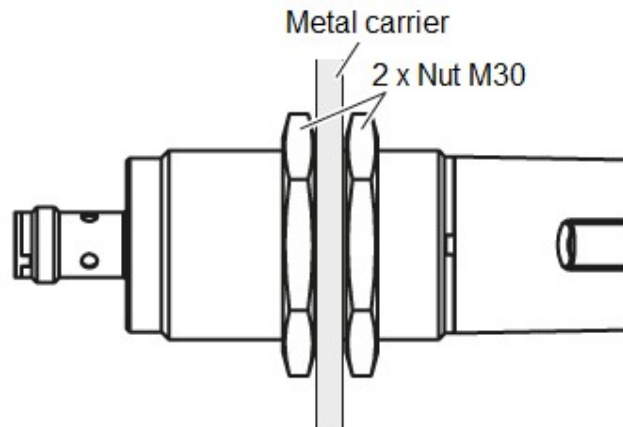

Figure 2: BF-IDU08 mounted on metal carrier using 2 x Nut M30

The antennas of the identification system BIS U transmit ultra-high frequency electromagnetic waves. People should not remain within the near enclosure of the UHF antenna over long time periods (several hours). The mounting position of the BF-IDU08 should take respect to a clearance area of about 25cm to workplaces.

# BF-IDU08

RFID-Reader

# BALLUFF

## Setup and Operation

The BF-IDU08 device will operate when connected to an IO-Link-Master that provides power supply and implements the BF-IDU08 RFID-Reader protocol.

Device behavior e.g. transmission power or operating modes can be setup via different parameters. Protocol description and available parameters are described in the firmware configuration manual.

## Status Indicators

The device will show its status using RGB LEDs located at the M12 plug. Depending on the device state the LED changes color and lighting mode (static, blink slow, blink fast).

Color	Mode	Status
Green	Static	Device powered and ready for operation
	Blink slow	IO-Link connection active
White	Static	Device powered and ready for operation, diagnostic functions disabled
Yellow	Static	RFID-Tag inventoried
	Blink fast	Device operation out of specified range
Blue	Static	Maintenance required
	Blink slow	Device locating mode to physically locate device
	Blink fast	RFID antenna active
Red	Static	Device teaching mode or device error, refer to error code
	Blink fast	IO-Kink connection short circuit detected

## Electrical Data

Supply voltage	18...30 V DC
Current draw (@24V)	≤ 200 mA
China Version	
Operating Frequency	920.5...924.5 MHz
Maximum Transmit Power (ERP)	18 dBm (63 mW)
USA / Canada Version	
Operating Frequency	902.25...926.,75 MHz
Maximum Transmit Power (EIRP)	20 dBm (100 mW) EIRP
Antenna Beam Width	< 160° (horizontal/vertical)
Antenna Polarization	Circular

## Mechanical Data

Housing material	Stainless steel / PBT
Dimensions (L x D)	98mm x 30mm
Weight	65g
Ambient temperature	0°C...+70°C