



LS40

GAMING HEADSET

USER GUIDE 

HEADSET



[L]

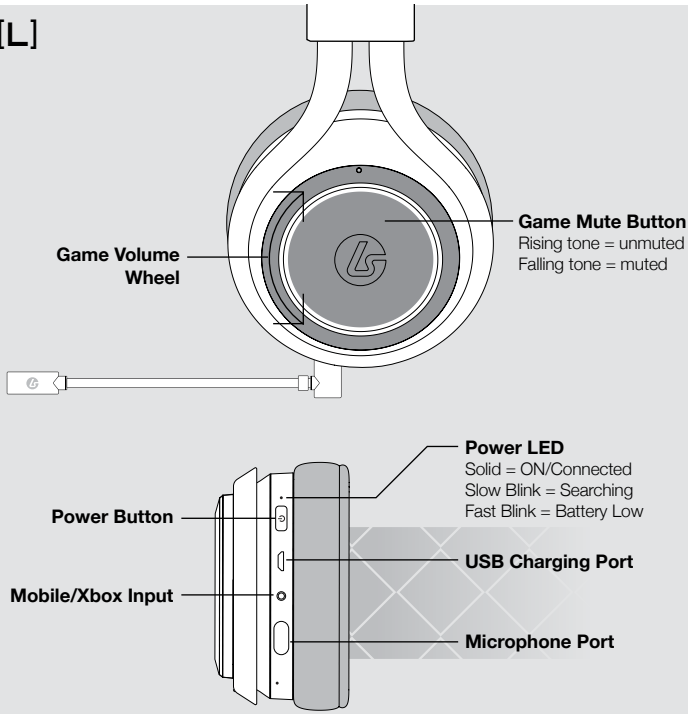

[R]

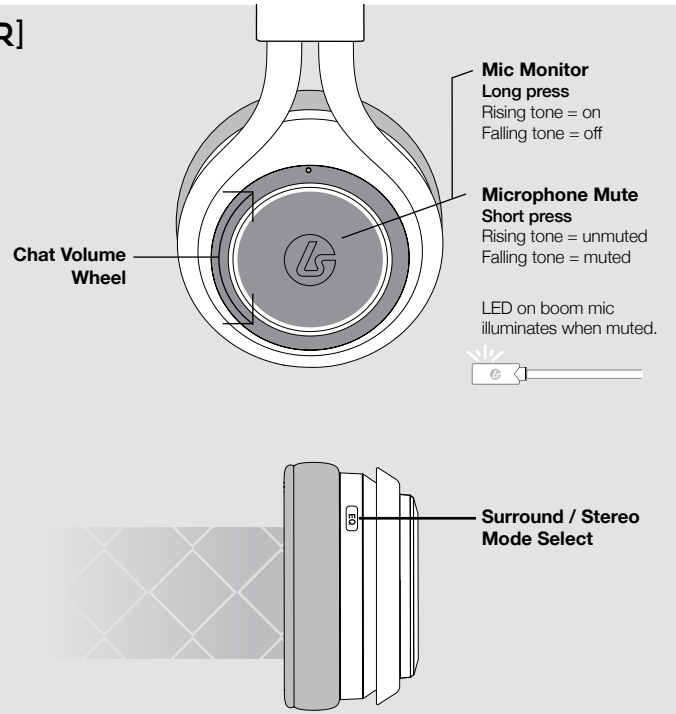

ACCESSORIES



BASE STATION

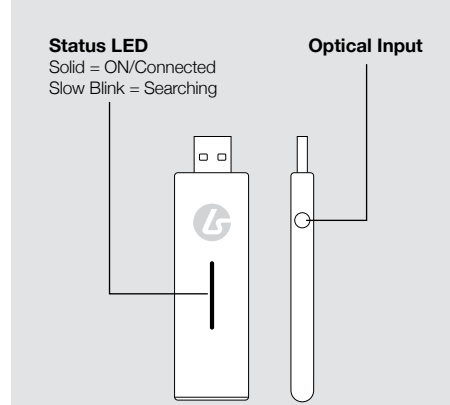
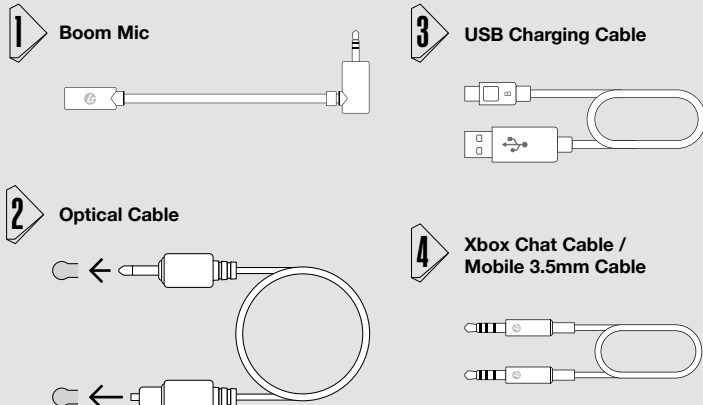

CHARGING



Connect the small end (micro-USB) of the charging cable to the headset. Connect the other end to a USB port. The LED on the headset will pulse while charging and turn solid when charging is complete.

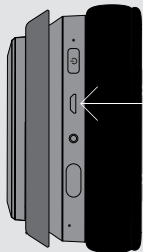

When battery has less than 15% power remaining, unit beeps twice every 10 minutes.



MICROPHONE



The LS40 includes an optional boom microphone. When this microphone is removed, an internal microphone is activated.

To connect the boom microphone, simply insert it into the port on the bottom of the headset.

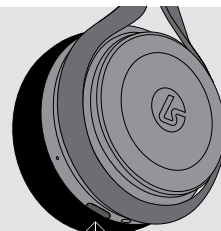

CONNECTING TO CONSOLE [PS4, PS3, & XBOX ONE]



STEP 1

Connect the wide end of the optical cable to the optical port on the rear of the Console. PS4 Slim does not include an optical output. Requires connection through TV or a separate HDMI to Optical adapter (not included). See our website FAQ.

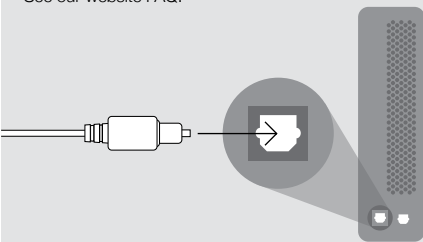

STEP 2

Connect the thin end of the optical cable to the optical port on the side of the Base Station.

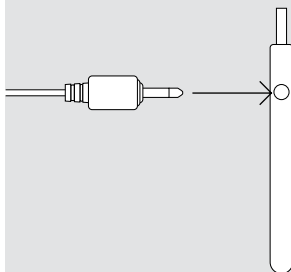

STEP 3

Plug the Base Station into a USB port on the Console.

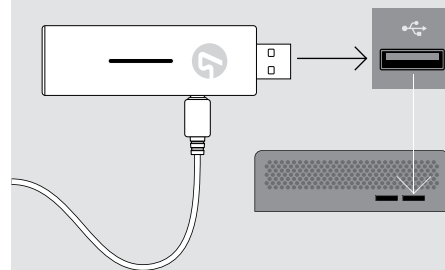

PLAYSTATION 4 SETUP



- 1 Go into **Settings > Sound and Screen > Audio Output Settings > Primary Output Port** and select 'Digital Out (Optical)'
- 2 Check the box for 'Dolby Digital 5.1'
- 3 Go into **Settings > Audio Output Settings > Audio Format (Priority)** and select 'Bitstream (Dolby)'
- 4 Go into **Settings > Devices > Audio Devices** and set both the 'Input Device' and 'Output Device' to 'USB Headset (LucidSound)'
- 5 Set the Output to Headphone to 'Chat Audio'
- 6 Set the 'Volume Control (Headphones)' to maximum

PLAYSTATION 3 SETUP



- 1 Go into **Settings > Sound Settings > Audio Output Settings > Optical Digital**
- 2 Check the box marked 'Dolby Digital 5.1 Ch.'
- 3 Go into **Settings > Accessory Settings > Audio Device Settings** and set the 'Input Device' and 'Output Device' to 'LucidSound'

XBOX ONE SETUP



Controllers with 3.5mm port

- 1 Always turn on the headset before turning on the controller
- 2 Connect one end of the Xbox One chat cable to the 3.5mm port on the headset and the other end to the 3.5mm port on the Controller
- 3 On the Xbox One, go into **All settings > Kinect & devices > Devices & accessories** and choose the Xbox One Wireless Controller in use
- 4 Select 'Volume' and set 'Headset volume' to maximum and 'Mic monitoring' to minimum. Make sure that 'Headset mic' is turned to 'On'
- 5 If it appears, set 'Headset chat mixer' all the way to the right for 100% chat
- 6 On the Xbox One, go into **All settings > Display & sound**. Under '**Audio Output**' select 'Optical audio' and choose 'Bitstream out.' Then select 'Bitstream format' and choose 'Dolby Digital'

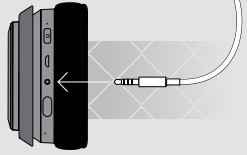

Controllers without 3.5mm port

If the Xbox One Controller does not have a 3.5mm port, an Xbox One Stereo Headset adapter is required (not included).

- 1 Connect one end of the Xbox One chat cable to the 3.5mm port on the headset and the other end to the 3.5mm port on the Stereo Headset Adapter
- 2 Adjust the game/chat balance on the Stereo Headset Adapter to 100% chat and increase the volume on the adapter to maximum
- 3 On the Xbox One, go into **All settings > Display & sound**. Under '**Audio Output**' select 'Optical audio' and choose 'Bitstream out.' Then select 'Bitstream format' and choose 'Dolby Digital'

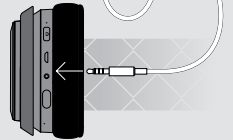

PC / MAC SETUP



- 1 Connect the dongle to a USB port on the computer and power on the headset
- 2 In the computer's sound settings, set the default sound output to "LucidSound PC Gaming Audio" for game audio
- 3 In the chat program being used, choose "LucidSound PC Chat Audio" for both the Input and Output

USB audio for stereo use. Optical connection with Dolby Live required for surround sound.

MOBILE



- 1 Connect one end of the mobile cable to the 3.5mm input on the headset and the other end to the 3.5mm output on the mobile device
- 2 The headset will only work in passive (OFF) mode. (Note that the volume, EQ, and mute features will not function)
- 3 Press the button on the left earcup to control music, voice commands, and phone calls

SUPPORT



Model No: LS40RX
Model No: LS40TX

IC: 21203-16302
IC: 21203-16301

LucidSound, Inc.
Made in China



This device complies with Industry Canada licence-exempt RSS-247 standard. Operation is subject to the following two conditions: (1) this device may not cause interference, and (2) this device must accept any interference, including interference that may cause undesired operation of the device.

IC Radiation Exposure Statement:

This equipment complies with IC RSS-102 radiation exposure limits set forth for an uncontrolled environment. This equipment should be installed and operated with minimum distance 0.5 cm between the radiator and your body.

For DTS patents, see <http://patents.dts.com>.

Manufactured under license from DTS, Inc. DTS, the Symbol, DTS and the Symbol together, the DTS Headphone:X logo are registered trademarks or trademarks of DTS, Inc. in the United States and/or other countries. © DTS, Inc. All rights reserved.

Manufactured under license from Dolby Laboratories. Dolby and the double-D symbol are trademarks of Dolby Laboratories.

©2017 Lucid Sound, Inc. 2150 Palomar Airport Rd., Suite 201, Carlsbad, CA 92011 U.S.A. LucidSound and the Lucid Sound logo, are trademarks of Lucid Sound, Inc., its subsidiaries, and affiliates. The shape and design of this product are a trade dress of Lucid Sound, Inc., its subsidiaries and affiliates. All rights reserved. All other product names and images are trademarks or registered trademarks of their respective owners. Made in China. Product features, appearance and specifications may be subject to change without notice. Please retain this information for future reference.

United States

LucidSound, Inc. warrants this product to be free from defects in materials and workmanship for the warranty period. This non-transferable, 1-year limited warranty is only to you, the first end-user purchaser. If a defect covered by this warranty occurs AND you provide proof of purchase, LucidSound, Inc., at its option, will repair or replace the product at no charge (excluding shipping to LucidSound).

The LucidSound, Inc., 1-year limited warranty is available to customers in the United States. Your sole and exclusive remedy is repair or replacement of your LucidSound product. In no event shall LucidSound's liability exceed the original purchase price of the product. This warranty does not apply to: (a) normal wear and tear or abusive use; (b) industrial, professional or commercial use; (c) if the product has been tampered with or modified.

To receive warranty service, please contact us at: **lucidsound.com**
(toll free) 888-661-4469
1-760-579-6969

Australia

Our goods come with guarantees that cannot be excluded under the Australian Consumer Law. You are entitled to a 1 year replacement warranty in which you are entitled to have the goods repaired or replaced if the goods fail to be of acceptable quality and the failure does not amount to a major failure.

What you must do:

If a defect has appeared within 90 days from the date of purchase, the product may be returned to the retailer for a replacement.

If a defect has appeared after 90 days from the date of purchase, you must initiate a repair by following the online repair process at www.lucidsound.com.au.

Once all details are completed, you will receive a return authorisation number.

Then label and ship your LucidSound headset – including the return authorisation (RA) number, freight prepaid, to LucidSound's authorised repair centre.

LucidSound
c/o Tecworks International Pty Ltd
Unit 1 / 12 Tollis Place
Seven Hills NSW 2141

Please ensure the return authorisation (RA) number is prominently displayed on the outside of your packaging.

The cost incurred to return the product to the retailer or to the authorised repair centre as part of a Warranty claim are your responsibility.

What we will do:

During the Warranty Period, we will, at our option, repair or replace the product or any defective parts. We will also bear the reasonable costs of standard return shipping. If this cannot be done, then we will refund the purchase price to you.

AU wholesale distributor:

Bluemouth Interactive Pty Ltd, Level 2, 2 Darling Street, South Yarra, Victoria, 3141
Email: support@bluemouth.com.au





Attention!!!

Do not return this product to the store.
Please contact LucidSound for help first.

If you have any setup, troubleshooting questions,
or are missing parts:

 lucidsound.com

 support@lucidsound.com

 888-661-4469

Federal Communication Commission Interference Statement

This equipment has been tested and found to comply with the limits for a Class B digital device, pursuant to Part 15 of the FCC Rules. These limits are designed to provide reasonable protection against harmful interference in a residential installation.

This equipment generates, uses and can radiate radio frequency energy and, if not installed and used in accordance with the instructions, may cause harmful interference to radio communications. However, there is no guarantee that interference will not occur in a particular installation. If this equipment does cause harmful interference to radio or television reception, which can be determined by turning the equipment off and on, the user is encouraged to try to correct the interference by one of the following measures:

- . Reorient or relocate the receiving antenna.
- . Increase the separation between the equipment and receiver.
- . Connect the equipment into an outlet on a circuit different from that to which the receiver is connected.
- . Consult the dealer or an experienced radio/TV technician for help.

FCC Caution: To assure continued compliance, any changes or modifications not expressly approved by the party responsible for compliance could void the user's authority to operate this equipment. (Example - use only shielded interface cables when connecting to computer or peripheral devices).

FCC Radiation Exposure Statement

This equipment complies with FCC RF radiation exposure limits set forth for an uncontrolled environment.

This transmitter must not be co-located or operating in conjunction with any other antenna or transmitter.

This device complies with Part 15 of the FCC Rules. Operation is subject to the following two conditions: (1) This device may not cause harmful interference, and (2) This device must accept any interference received, including interference that may cause undesired operation.