

FCC RADIO TEST REPORT

FCC ID: 2AGZ8DRW533VPBU

Sample : RC DRONE

Trade Mark : N/A

Main Model : DRW533VPBU

Additional Model : N/A

Report No. : 23070109ER-61

Prepared for

DOWELLIN TOYS FACTORY

1 Road FengXin ChengHai District, ShanTou City,GuangDong, China

Prepared by

Global United Technology Services Co. Ltd.

No. 123-128, Tower A, Jinyuan Business Building, No.2, Laodong Industrial Zone, Xixiang Road, Baoan District, Shenzhen, Guangdong, China 518102

TEST RESULT CERTIFICATION

Applicant : DOWELLIN TOYS FACTORY
Address : 1 Road FengXin ChengHai District, ShanTou City,GuangDong,
 China
Manufacturer : DOWELLIN TOYS FACTORY
Address : 1 Road FengXin ChengHai District, ShanTou City,GuangDong,
 China

Product description

Product..... : RC DRONE
Trade Mark : N/A
Model Name : DRW533VPBU

Test Methods..... : FCC Rules and Regulations Part 15 Subpart C Section 15.249,
ANSI C63.10: 2013

This device described above has been tested by Global United Technology Services Co. Ltd., and the test results show that the equipment under test (EUT) is in compliance with the FCC requirements. And it is applicable only to the tested sample identified in the report. This report shall not be reproduced except in full, without the written approval, this document may be altered or revised by Global United Technology Services Co. Ltd., personnel only, and shall be noted in the revision of the document.

Date of Test

Date (s) of performance of tests..... : Jul. 01, 2023 ~ Jul. 10, 2023
Date of Issue..... : Jul. 20, 2023
Test Result..... : Pass



Prepared By:	 <hr/> Project Engineer	Date:	2023-7-20 <hr/>
Check By:	 <hr/> Reviewer	Date:	2023-7-20 <hr/>

Table of Contents

Page

1 TEST SUMMARY	4
2 GENERAL INFORMATION	6
2.1 GENERAL DESCRIPTION OF EUT	6
2.2 CARRIER FREQUENCY OF CHANNELS	7
2.3 TEST MODE	7
2.4 TEST SETUP	7
2.5 DESCRIPTION TEST PERIPHERAL AND EUT PERIPHERAL	8
2.6 MEASUREMENT INSTRUMENTS LIST	9
3 CONDUCTED EMISSION	11
3.1 TEST LIMIT	11
3.2 TEST SETUP	11
3.3 TEST PROCEDURE	12
3.4 TEST RESULT	12
4 RADIATED EMISSION	13
4.1 TEST LIMIT	13
4.2 TEST SETUP	14
4.3 TEST PROCEDURE	15
4.4 TEST RESULT	15
5 BAND EDGE	21
5.1 TEST LIMIT	21
5.2 TEST PROCEDURE	21
5.3 TEST RESULT	21
6 20DB BANDWIDTH	24
6.1 TEST SETUP (BLOCK DIAGRAM OF CONFIGURATION)	24
6.2 MEASUREMENT EQUIPMENT USED	24
6.3 TEST PROCEDURE	24
6.4 TEST RESULT	24
7 ANTENNA REQUIREMENT	27
8 PHOTO OF TEST	28
8.1 RADIATED EMISSION	28
8.2 RF CONDUCTED	29

1 TEST SUMMARY

1.1 TEST PROCEDURES AND RESULTS

ITEM	STANGARD	RESULT
CONDUCTED EMISSION	FCC Part 15.207	N/A
RADIATED EMISSION	FCC Part 15.209/15.249	COMPLIANT
BAND EDGE	FCC Part 15.249/15.205	COMPLIANT
20dB BANDWIDTH	FCC Part 15.215	COMPLIANT
ANTENNA REQUIREMENT	FCC Part 15.203	COMPLIANT

1.2 TEST FACILITY

Test Firm : Global United Technology Services Co. Ltd.

Address : No. 123-128, Tower A, Jinyuan Business Building, No.2, Laodong Industrial Zone, Xixiang Road, Baoan District, Shenzhen, Guangdong, China 518102

The test facility is recognized, certified, or accredited by the following organizations:

- **FCC—Registration No.: 381383**

Designation Number: CN5029

Global United Technology Services Co., Ltd., Shenzhen EMC Laboratory has been registered and fully described in a report filed with the (FCC) Federal Communications Commission.

The acceptance letter from the FCC is maintained in files.

- **IC —Registration No.: 9079A**

CAB identifier: CN0091

The 3m Semi-anechoic chamber of Global United Technology Services Co., Ltd. has been registered by Certification and Engineering Bureau of Industry Canada for radio equipment testing

- **NVLAP (LAB CODE:600179-0)**

Global United Technology Services Co., Ltd., is accredited by the National Voluntary Laboratory Accreditation Program (NVLAP).

1.3 MEASUREMENT UNCERTAINTY

The reported uncertainty of measurement $y \pm U$, where expanded uncertainty U is based on a standard uncertainty multiplied by a coverage factor of $k=2$, providing a level of confidence of approximately 95 %.

A. Conducted Measurement:

Test Site	Method	Measurement Frequency Range	U, (dB)	NOTE
UNI	ANSI	9kHz ~ 150kHz	2.96	
		150kHz ~ 30MHz	2.44	

B. Radiated Measurement:

Test Site	Method	Measurement Frequency Range	U, (dB)	NOTE
UNI	ANSI	9kHz ~ 30MHz	2.50	
		30MHz ~ 1000MHz	4.80	
		Above 1000MHz	4.13	

2 GENERAL INFORMATION

2.1 GENERAL DESCRIPTION OF EUT

Product:	RC DRONE
Trade Name:	N/A
Main Model:	DRW533VPBU
Additional Model:	N/A
Model Difference:	N/A
FCC ID:	2AGZ8DRW533VPBU
Frequency Range:	2458MHz-2478MHz
Number of Channels:	5CH
Modulation Type:	GFSK
Antenna Type:	Internal Antenna
Antenna Gain:	0dBi
Battery:	N/A
Adapter:	N/A
Power Source:	DC 6V

2.2 CARRIER FREQUENCY OF CHANNELS

Channel List							
Channel	Frequency (MHz)	Channel	Frequency (MHz)	Channel	Frequency (MHz)	Channel	Frequency (MHz)
01	2458	02	2463	03	2468	04	2473
05	2478						

2.3 TEST MODE

The EUT was programmed to be in continuously transmitting mode.

Channel List		
Test Channel	EUT Channel	Test Frequency (MHz)
Low channel	CH01	2458.000
Middle channel	CH03	2468.000
High channel	CH05	2478.000

2.4 TEST SETUP

Operation of EUT during Radiation testing:



Operation of EUT during RF Conducted testing:

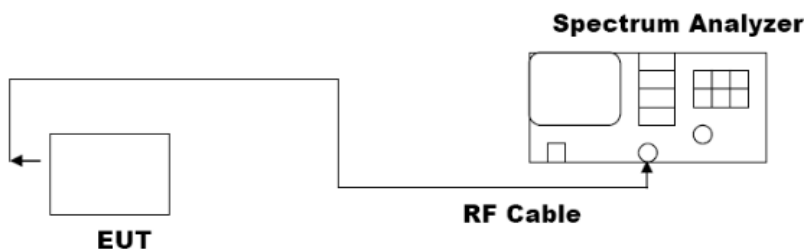

2.5 DESCRIPTION TEST PERIPHERAL AND EUT PERIPHERAL

The EUT has been tested as an independent unit together with other necessary accessories or support units. The following support units or accessories were used to form a representative test configuration during the tests.

Item	Equipment	Mfr/Brand	Model/Type No.	Note
E-1	RC DRONE	N/A	DRW533VPBU	EUT

Note:

1. The support equipment was authorized by Declaration of Confirmation.
2. For detachable type I/O cable should be specified the length in cm in 『Length』 column.
3. “YES” is means “shielded” “with core”; “NO” is means “unshielded” “without core”.

2.6 MEASUREMENT INSTRUMENTS LIST

Radiated Emission:						
Item	Test Equipment	Manufacturer	Model No.	Inventory No.	Cal.Date (mm-dd-yy)	Cal.Due date (mm-dd-yy)
1	3m Semi- Anechoic Chamber	ZhongYu Electron	9.2(L)*6.2(W)* 6.4(H)	GTS250	June 23, 2021	June 22, 2024
2	Control Room	ZhongYu Electron	6.2(L)*2.5(W)* 2.4(H)	GTS251	N/A	N/A
3	EMI Test Receiver	Rohde & Schwarz	ESU26	GTS203	April 14, 2023	April 13, 2024
4	BiConiLog Antenna	SCHWARZBECK MESS-ELEKTRONIK	VULB9168	GTS640	March 19, 2023	March 18, 2025
5	Double -ridged waveguide horn	SCHWARZBECK MESS-ELEKTRONIK	BBHA 9120 D	GTS208	April 17, 2023	April 16, 2025
6	EMI Test Software	AUDIX	E3	N/A	N/A	N/A
7	Coaxial Cable	GTS	N/A	GTS213	April 21, 2023	April 20, 2024
8	Coaxial Cable	GTS	N/A	GTS211	April 21, 2023	April 20, 2024
9	Coaxial cable	GTS	N/A	GTS210	April 21, 2023	April 20, 2024
10	Coaxial Cable	GTS	N/A	GTS212	April 21, 2023	April 20, 2024
11	Wideband Radio Communication Tester	Rohde & Schwarz	CMW500	GTS575	April 14, 2023	April 13, 2024
12	Loop Antenna	ZHINAN	ZN30900A	GTS534	Nov. 29, 2022	Nov. 28, 2023
13	Broadband Preampfier	SCHWARZBECK	BBV9718	GTS535	April 14, 2023	April 13, 2024
14	Amplifier(1GHz-26.5GHz)	HP	8449B	GTS601	April 14, 2023	April 13, 2024
15	Horn Antenna (18-26.5GHz)	/	UG-598A/U	GTS664	Oct. 30, 2022	Oct. 29, 2023
16	Horn Antenna (26.5-40GHz)	A.H Systems	SAS-573	GTS665	Oct. 30, 2022	Oct. 29, 2023
17	FSV-Signal Analyzer (10Hz-40GHz)	Keysight	FSV-40-N	GTS666	March 13, 2023	March 12, 2024
18	Amplifier	/	LNA-1000-30S	GTS650	April 14, 2023	April 13, 2024
19	CDNE M2+M3-16A	HCT	30MHz-300MHz	GTS668	Dec. 20, 2022	Dec.19, 2023
20	Thermo meter	JINCHUANG	GSP-8A	GTS643	April 19, 2023	April 18, 2024

RF Conducted Test:						
Item	Test Equipment	Manufacturer	Model No.	Serial No.	Cal.Date (mm-dd-yy)	Cal.Due date (mm-dd-yy)
1	MXA Signal Analyzer	Agilent	N9020A	GTS566	April 14, 2023	April 13, 2024
2	EMI Test Receiver	R&S	ESCI 7	GTS552	April 14, 2023	April 13, 2024
3	PSA Series Spectrum Analyzer	Agilent	E4440A	GTS536	April 14, 2023	April 13, 2024
4	MXG vector Signal Generator	Agilent	N5182A	GTS567	April 14, 2023	April 13, 2024
5	ESG Analog Signal Generator	Agilent	E4428C	GTS568	April 14, 2023	April 13, 2024
6	USB RF Power Sensor	DARE	RPR3006W	GTS569	April 14, 2023	April 13, 2024
7	RF Switch Box	Shongyi	RFSW3003328	GTS571	April 14, 2023	April 13, 2024
8	Programmable Constant Temp & Humi Test Chamber	WEWON	WHTH-150L-40-880	GTS572	April 14, 2023	April 13, 2024
9	Thermo meter	JINCHUANG	GSP-8A	GTS641	April 19, 2023	April 18, 2024

3 CONDUCTED EMISSION

3.1 TEST LIMIT

For unintentional device, according to § 15.207(a) Line Conducted Emission Limits is as following

Frequency (MHz)	Maximum RF Line Voltage (dB μ V)			
	CLASS A		CLASS B	
	Q.P.	Ave.	Q.P.	Ave.
0.15~0.50	79	66	66~56*	56~46*
0.50~5.00	73	60	56	46
5.00~30.0	73	60	60	50

* Decreasing linearly with the logarithm of the frequency.

For intentional device, according to §15.207(a) Line Conducted Emission Limit is same as above table.

3.2 TEST SETUP

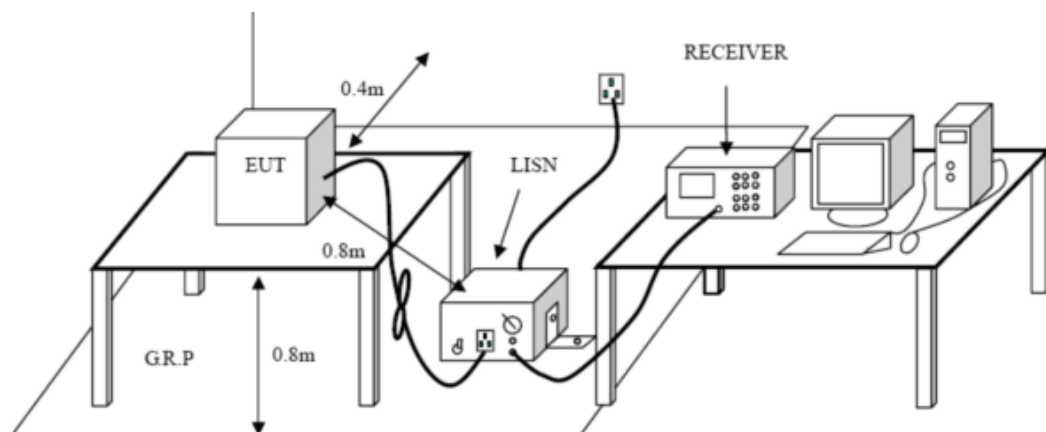

3.3 TEST PROCEDURE

1. The equipment was set up as per the test configuration to simulate typical actual usage per the user's manual. The EUT is placed on a wooden table with a height of 0.8 meters is used and is placed on the ground plane as per ANSI C63.10.
2. Support equipment, if needed, was placed as per ANSI C63.10.
3. All I/O cables were positioned to simulate typical actual usage as per ANSI C63.10.
4. If a EUT received DC power from the USB Port of Notebook PC, the PC's adapter received AC120V/60Hz power through a Line Impedance Stabilization Network (LISN) which supplied power source and was grounded to the ground plane.
5. All support equipments received AC power from a second LISN, if any.
6. The EUT test program was started. Emissions were measured on each current carrying line of the EUT using a spectrum Analyzer / Receiver connected to the LISN powering the EUT. The LISN has two monitoring points: Line 1 (Hot Side) and Line 2 (Neutral Side). Two scans were taken: one with Line 1 connected to Analyzer / Receiver and Line 2 connected to a 50 ohm load; the second scan had Line 1 connected to a 50 ohm load and Line 2 connected to the Analyzer / Receiver.
7. Analyzer / Receiver scanned from 150 kHz to 30MHz for emissions in each of the test modes.

3.4 TEST RESULT

N/A

Remark:

The EUT is powered by battery.

4 RADIATED EMISSION

4.1 TEST LIMIT

For unintentional device, according to § 15.209(a), except for Class B digital devices, the field strength of radiated emissions from unintentional radiators at a distance of 3 meters shall not exceed the following values:

Frequency	Field strength (microvolt/meter)	Limit (dBuV/m)	Remark	Measurement distance (m)
0.009MHz-0.490MHz	2400/F (kHz)	-	Quasi-peak	300
0.490MHz-1.705MHz	24000/F (kHz)	-	Quasi-peak	30
1.705MHz-30MHz	30	-	Quasi-peak	30
30MHz-88MHz	100	40.0	Quasi-peak	3
88MHz-216MHz	150	43.5	Quasi-peak	3
216MHz-960MHz	200	46.0	Quasi-peak	3
960MHz-1GHz	500	54.0	Quasi-peak	3
Above 1GHz	500	54.0	Average	3
		74.0	Peak	3

For intentional device, according to § 15.209(a), the general requirement of field strength of radiated emissions from intentional radiators at a distance of 3 meters shall not exceed the above table.

Limit: (Field strength of the fundamental signal)

Frequency	Limit (dBuV/m @3m)	Remark
2400MHz-2483.5MHz	94.0	Average Value
	114.0	Peak Value

4.2 TEST SETUP

1. Radiated Emission Test-Up Frequency Below 30MHz

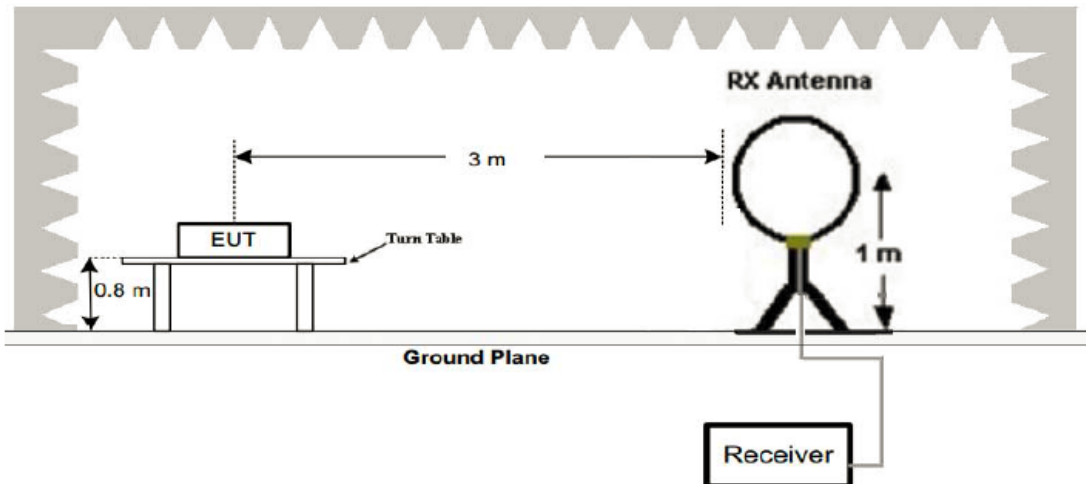

2. Radiated Emission Test-Up Frequency 30MHz~1GHz

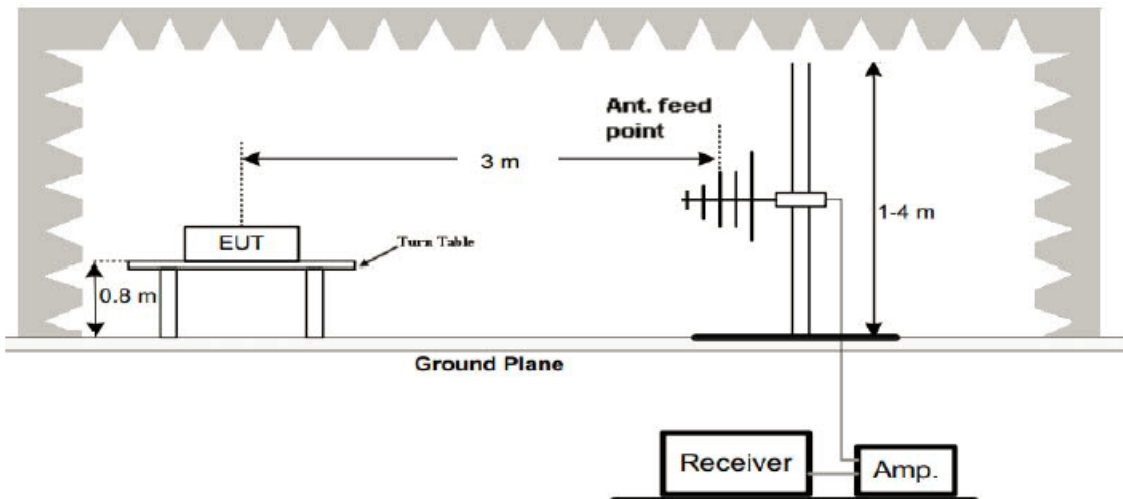

3. Radiated Emission Test-Up Frequency Above 1GHz

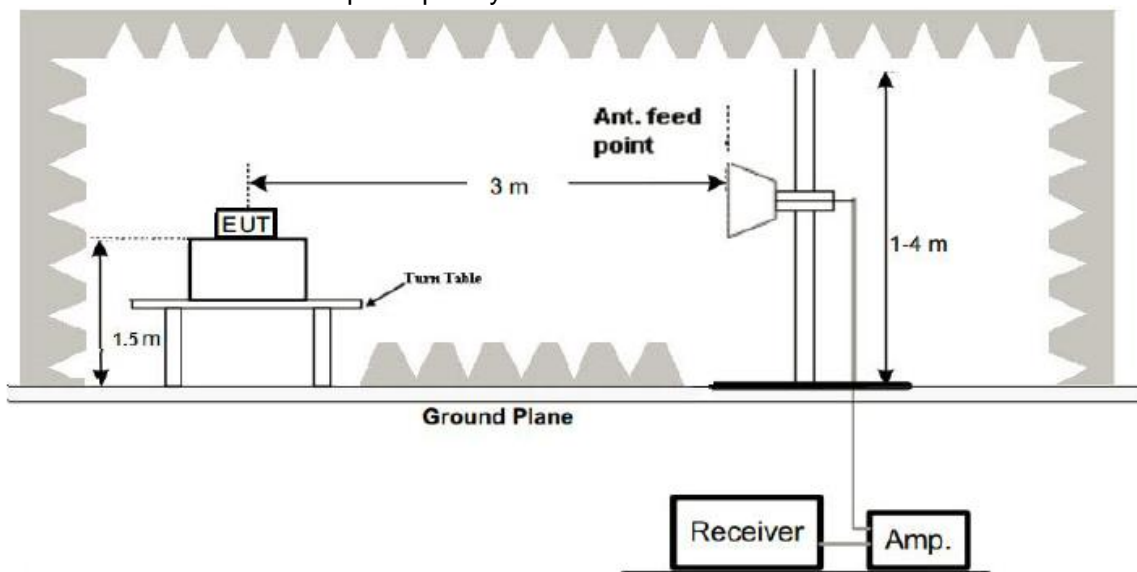

4.3 TEST PROCEDURE

1. Below 1GHz measurement the EUT is placed on turntable which is 0.8m above ground plane.
And above 1GHz measurement EUT was placed on low permittivity and low tangent turn table which is 1.5m above ground plane.
2. The turntable shall be rotated for 360 degrees to determine the position of maximum emission level.
3. EUT is set 3m away from the receiving antenna, which is varied from 1m to 4m to find out the highest emissions.
4. Maximum procedure was performed on the six highest emissions to ensure EUT compliance.
5. And also, each emission was to be maximized by changing the polarization of receiving antenna both horizontal and vertical.
6. Repeat above procedures until the measurements for all frequencies are complete.
7. The test frequency range from 9kHz to 25GHz per FCC PART 15.33(a).

Note:

For battery operated equipment, the equipment tests shall be performed using a new battery.

4.4 TEST RESULT

PASS

Remark:

1. All modes were test at Low, Middle, and High channel, only the worst result of GFSK Low Channel was reported for below 1GHz test.
2. By preliminary testing and verifying three axis (X, Y and Z) position of EUT transmitted status, it was found that "X axis" position was the worst, and test data recorded in this report.
3. Radiated emission test from 9kHz to 10th harmonic of fundamental was verified, and no emission found except system noise floor in 9kHz to 30MHz and not recorded in this report.

Below 1GHz Test Results:

Temperature:	24°C	Relative Humidity:	48%
Test Date:	Jul. 03, 2023	Pressure:	1010hPa
Test Voltage:	DC 6V	Phase:	Horizontal
Test Mode:	Transmitting mode of GFSK 2458.0MHz		

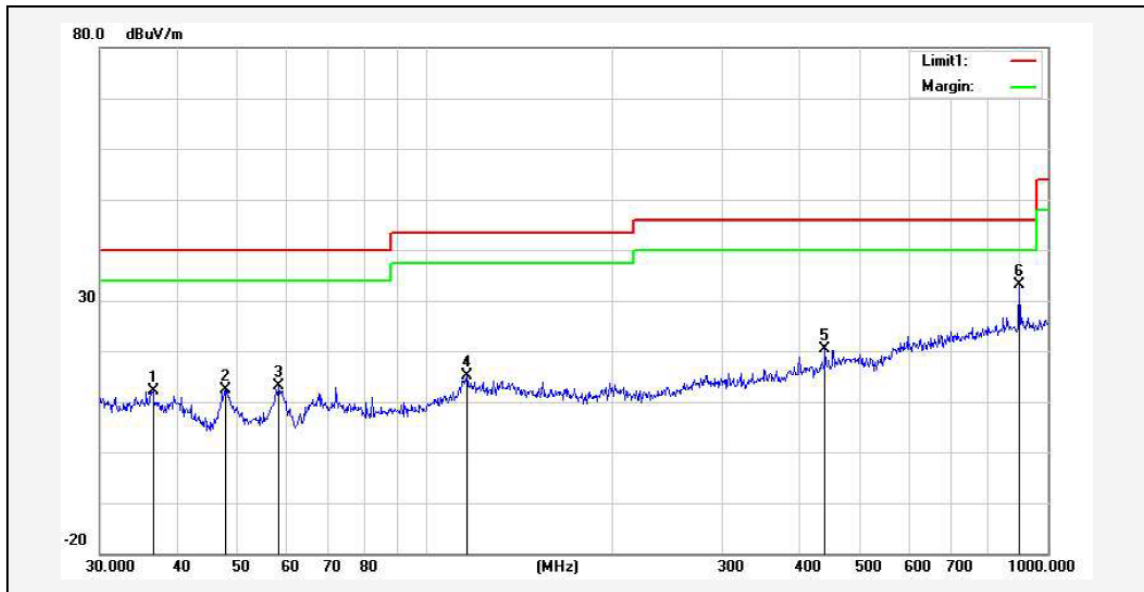

No.	Frequency (MHz)	Reading (dBuV)	Correction factor(dB/m)	Result (dBuV/m)	Limit (dBuV/m)	Margin (dB)	Degree (deg.)	Height (cm)	Remark
1	36.5092	30.53	-18.41	12.12	40.00	-27.88			peak
2	47.6586	34.51	-22.05	12.46	40.00	-27.54			peak
3	58.2030	35.97	-22.89	13.08	40.00	-26.92			peak
4	116.5401	30.83	-15.62	15.21	43.50	-28.29			peak
5	438.6554	30.47	-10.04	20.43	46.00	-25.57			peak
6*	900.1474	34.82	-1.77	33.05	46.00	-12.95			peak

Temperature:	24°C	Relative Humidity:	48%
Test Date:	Jul. 03, 2023	Pressure:	1010hPa
Test Voltage:	DC 6V	Phase:	Vertical
Test Mode:	Transmitting mode of GFSK 2458.0MHz		

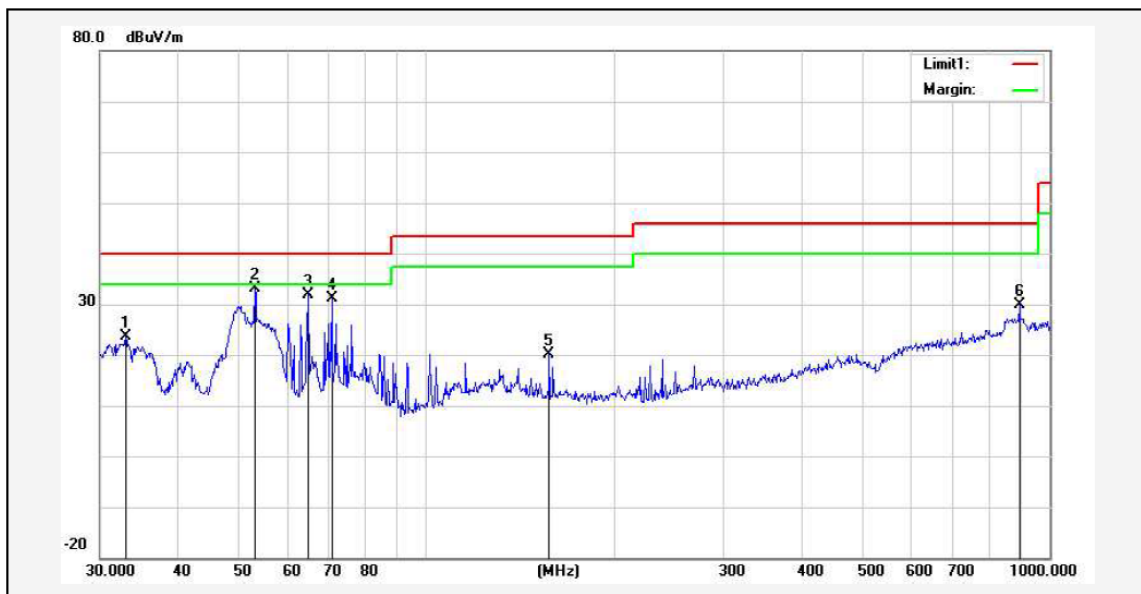

No.	Frequency (MHz)	Reading (dBuV)	Correction factor(dB/m)	Result (dBuV/m)	Limit (dBuV/m)	Margin (dB)	Degree (deg.)	Height (cm)	Remark
1	32.9791	42.55	-18.96	23.59	40.00	-16.41			peak
2*	53.1313	56.02	-22.79	33.23	40.00	-6.77			peak
3	64.6594	54.30	-22.40	31.90	40.00	-8.10			peak
4	70.5836	51.89	-20.67	31.22	40.00	-8.78			peak
5	157.5588	36.91	-16.70	20.21	43.50	-23.29			peak
6	893.8567	35.09	-5.32	29.77	46.00	-16.23			peak

Remark: Result = Reading Level + Factor, Margin = Result – Limit
 Factor = Ant. Factor + Cable Loss – Pre-amplifier

Remark:

1. Measuring frequencies from 9 kHz to the 1 GHz, Radiated emission test from 9kHz to 30MHz was verified, and no any emission was found except system noise floor.
2. * denotes emission frequency which appearing within the Restricted Bands specified in provision of 15.205, then the general radiated emission limits in 15.209 apply.
3. The IF bandwidth of EMI Test Receiver between 30MHz to 1GHz was 120kHz, 1 MHz for measuring above 1 GHz, below 30MHz was 10kHz.

Above 1 GHz Test Results:

CH01 (2458.0MHz)

Horizontal:

Frequency	Reading Result	Factor	Emission Level	Limits	Margin	Detector
(MHz)	(dB μ V)	(dB)	(dB μ V/m)	(dB μ V/m)	(dB)	Type
2458	100.89	-5.84	95.05	114	-18.95	PK
2458	80.01	-5.84	74.17	94	-19.83	AV
4916	57.35	-3.64	53.71	74	-20.29	PK
4916	36.91	-3.64	33.27	54	-20.73	AV
7374	53.76	-0.95	52.81	74	-21.19	PK
7374	33.01	-0.95	32.06	54	-21.94	AV

Remark: Factor = Antenna Factor + Cable Loss – Pre-amplifier. Margin = Absolute Level – Limit

Vertical:

Frequency	Reading Result	Factor	Emission Level	Limits	Margin	Detector
(MHz)	(dB μ V)	(dB)	(dB μ V/m)	(dB μ V/m)	(dB)	Type
2458	100.55	-5.84	94.71	114	-19.29	PK
2458	79.91	-5.84	74.07	94	-19.93	AV
4916	57.67	-3.64	54.03	74	-19.97	PK
4916	37.25	-3.64	33.61	54	-20.39	AV
7374	54.04	-0.95	53.09	74	-20.91	PK
7374	33.56	-0.95	32.61	54	-21.39	AV

Remark: Factor = Antenna Factor + Cable Loss – Pre-amplifier. Margin = Absolute Level – Limit

CH03 (2468.0MHz)

Horizontal:

Frequency	Reading Result	Factor	Emission Level	Limits	Margin	Detector
(MHz)	(dB μ V)	(dB)	(dB μ V/m)	(dB μ V/m)	(dB)	Type
2468	100.42	-5.71	94.71	114	-19.29	PK
2468	79.24	-5.71	73.53	94	-20.47	AV
4936	56.69	-3.51	53.18	74	-20.82	PK
4936	36.25	-3.51	32.74	54	-21.26	AV
7404	53.1	-0.82	52.28	74	-21.72	PK
7404	32.35	-0.82	31.53	54	-22.47	AV

Remark: Factor = Antenna Factor + Cable Loss – Pre-amplifier. Margin = Absolute Level – Limit

Vertical:

Frequency	Reading Result	Factor	Emission Level	Limits	Margin	Detector
(MHz)	(dB μ V)	(dB)	(dB μ V/m)	(dB μ V/m)	(dB)	Type
2468	100.08	-5.71	94.37	114	-19.63	PK
2468	79.25	-5.71	73.54	94	-20.46	AV
4936	56.14	-3.51	52.63	74	-21.37	PK
4936	36.03	-3.51	32.52	54	-21.48	AV
7404	53.31	-0.82	52.49	74	-21.51	PK
7404	33.15	-0.82	32.33	54	-21.67	AV

Remark: Factor = Antenna Factor + Cable Loss – Pre-amplifier. Margin = Absolute Level – Limit

CH05 (2478.0MHz)

Horizontal:

Frequency	Reading Result	Factor	Emission Level	Limits	Margin	Detector
(MHz)	(dB μ V)	(dB)	(dB μ V/m)	(dB μ V/m)	(dB)	Type
2478	99.24	-5.65	93.59	114	-20.41	PK
2478	78.86	-5.65	73.21	94	-20.79	AV
4956	55.69	-3.43	52.26	74	-21.74	PK
4956	35.25	-3.43	31.82	54	-22.18	AV
7434	52.1	-0.75	51.35	74	-22.65	PK
7434	32.03	-0.75	31.28	54	-22.72	AV

Remark: Factor = Antenna Factor + Cable Loss – Pre-amplifier. Margin = Absolute Level – Limit

Vertical:

Frequency	Reading Result	Factor	Emission Level	Limits	Margin	Detector
(MHz)	(dB μ V)	(dB)	(dB μ V/m)	(dB μ V/m)	(dB)	Type
2478	98.9	-5.65	93.25	114	-20.75	PK
2478	78.29	-5.65	72.64	94	-21.36	AV
4956	55.98	-3.43	52.55	74	-21.45	PK
4956	35.12	-3.43	31.69	54	-22.31	AV
7434	52.31	-0.75	51.56	74	-22.44	PK
7434	32.21	-0.75	31.46	54	-22.54	AV

Remark: Factor = Antenna Factor + Cable Loss – Pre-amplifier. Margin = Absolute Level – Limit

Remark:

1. Measuring frequencies from 1 GHz to the 25 GHz.
2. "F" denotes fundamental frequency; "H" denotes spurious frequency. "E" denotes band edge frequency.
3. * denotes emission frequency which appearing within the Restricted Bands specified in provision of 15.205, then the general radiated emission limits in 15.209 apply.
4. Data of measurement within this frequency range shown "---" in the table above means the reading of emissions are attenuated more than 20dB below the permissible limits or the field strength is too small to be measured.
5. The IF bandwidth of EMI Test Receiver between 30MHz to 1GHz was 120kHz, 1 MHz for measuring above 1 GHz, below 30MHz was 10kHz. The resolution bandwidth of test receiver/spectrum analyzer is 1MHz and video bandwidth is 3MHz for peak measurement with peak detector at frequency above 1GHz. The resolution bandwidth of test receiver/spectrum analyzer is 1MHz and video bandwidth is 10Hz for Average measurement with peak detection at frequency above 1GHz.
6. When the test results of Peak Detected below the limits of Average Detected, the Average Detected is not need completed. For example: Top Channel at Fundamental 73.16dBuV/m(PK Value) <93.98(AV Limit), at harmonic 53.20 dBuV/m(PK Value) <54 dBuV/m(AV Limit), the Average Detected not need to completed.
7. All modes of operation were investigated and the worst-case emissions of $\pi/4$ DQPSK are reported.
8. For fundamental frequency, RBW >20dB BW, VBW>=3XRBW, PK detector for PK value, AV detector for AV value.

5 BAND EDGE

5.1 TEST LIMIT

FCC PART 15.249(d) Emissions radiated outside of the specified frequency bands, except for harmonics, shall be attenuated by at least 50 dB below the level of the fundamental or to the general radiated emission limits in §15.209, whichever is the lesser attenuation.

5.2 TEST PROCEDURE

The band edge compliance of RF radiated emission should be measured by following the guidance in ANSI C63.10 with respect to maximizing the emission by rotating the EUT, measuring the emission while the EUT is situated in three orthogonal planes (if appropriate), adjusting the measurement antenna height and polarization etc. Set RBW to 1MHz and VBW to 3MHz to measure the peak field strength and set RBW to 1MHz and VBW to 10Hz to measure the average radiated field strength. Peak detector is for both.

5.3 TEST RESULT

PASS

Operation Mode: TX CH01 (2458.0MHz)

Horizontal:

Frequency	Reading Result	Factor	Emission Level	Limits	Margin	Detector
(MHz)	(dB μ V)	(dB)	(dB μ V/m)	(dB μ V/m)	(dB)	Type
2310	56.82	-5.81	51.01	74	-22.99	PK
2310	/	-5.81	/	54	/	AV
2390	55.88	-5.84	50.04	74	-23.96	PK
2390	/	-5.84	/	54	/	AV
2400	57.23	-5.84	51.39	74	-22.61	PK
2400	/	-5.84	/	54	/	AV

Remark: Factor = Antenna Factor + Cable Loss – Pre-amplifier.

Vertical:

Frequency	Reading Result	Factor	Emission Level	Limits	Margin	Detector
(MHz)	(dB μ V)	(dB)	(dB μ V/m)	(dB μ V/m)	(dB)	Type
2310	56.55	-5.81	50.74	74	-23.26	PK
2310	/	-5.81	/	54	/	AV
2390	57.1	-5.84	51.26	74	-22.74	PK
2390	/	-5.84	/	54	/	AV
2400	57.64	-5.84	51.8	74	-22.2	PK
2400	/	-5.84	/	54	/	AV

Remark: Factor = Antenna Factor + Cable Loss – Pre-amplifier.

Operation Mode: TX CH05 (2478.0MHz)

Horizontal:

Frequency	Reading Result	Factor	Emission Level	Limits	Margin	Detector
(MHz)	(dB μ V)	(dB)	(dB μ V/m)	(dB μ V/m)	(dB)	Type
2483.5	55.58	-5.65	49.93	74	-24.07	PK
2483.5	/	-5.65	/	54	/	AV
2500	56.73	-5.72	51.01	74	-22.99	PK
2500	/	-5.72	/	54	/	AV

Remark: Factor = Antenna Factor + Cable Loss – Pre-amplifier.

Vertical:

Frequency	Reading Result	Factor	Emission Level	Limits	Margin	Detector
(MHz)	(dB μ V)	(dB)	(dB μ V/m)	(dB μ V/m)	(dB)	Type
2483.5	55.49	-5.65	49.84	74	-24.16	PK
2483.5	/	-5.65	/	54	/	AV
2500	56.58	-5.72	50.86	74	-23.14	PK
2500	/	-5.72	/	54	/	AV

Remark: Factor = Antenna Factor + Cable Loss – Pre-amplifier.

6 20dB BANDWIDTH

6.1 TEST SETUP (BLOCK DIAGRAM OF CONFIGURATION)

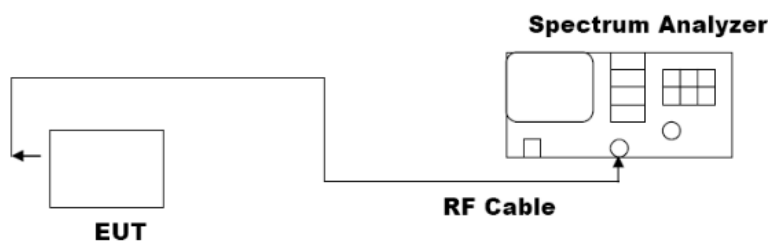

6.2 MEASUREMENT EQUIPMENT USED

Refer to Section 3.3.

6.3 TEST PROCEDURE

1. The RF output of EUT was connected to the spectrum analyzer by RF cable. The path loss was compensated to the results for each measurement.
2. Set to the maximum power setting and enable the EUT transmit continuously.
3. Make the measurement with the spectrum analyzer's resolution bandwidth (RBW) = 30 kHz. Set the Video bandwidth (VBW) = 100 kHz. In order to make an accurate measurement.
4. For 20dB Bandwidth Measurement, the spectrum analyzer's resolution bandwidth (RBW) is set 1-5% of the emission bandwidth and set the Video bandwidth (VBW) $\geq 3 * RBW$.
5. Measure and record the results in the test report.

6.4 TEST RESULT

PASS

GFSK Modulation:

Channel	Frequency (MHz)	20dB Bandwidth (MHz)	Result
Low Channel	2458.00	1.061	PASS
Middle Channel	2468.00	1.064	PASS
High Channel	2478.00	1.064	PASS

CH01: 2458.00MHz

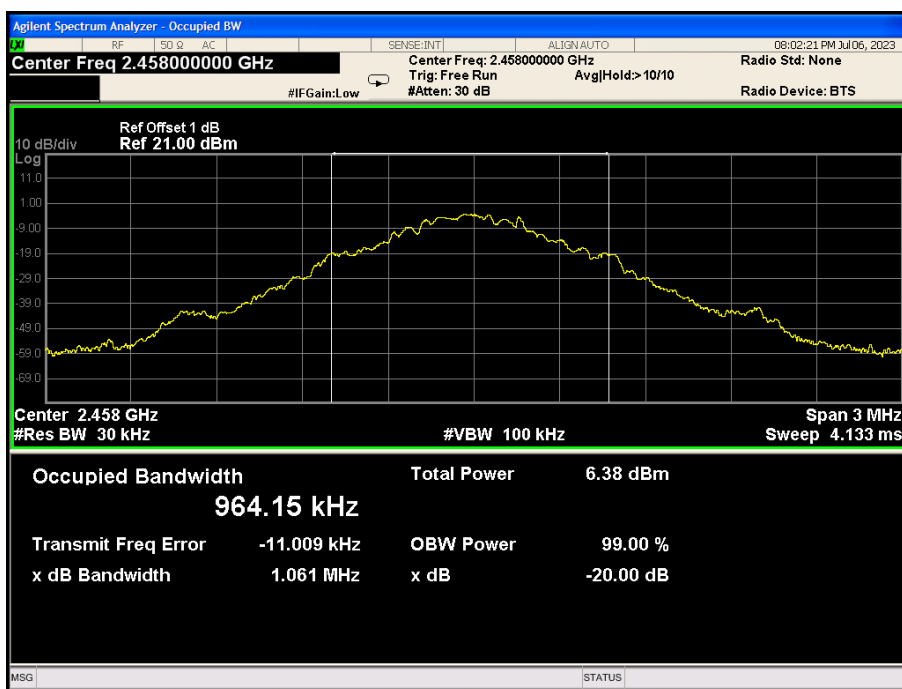

CH03: 2468.00MHz

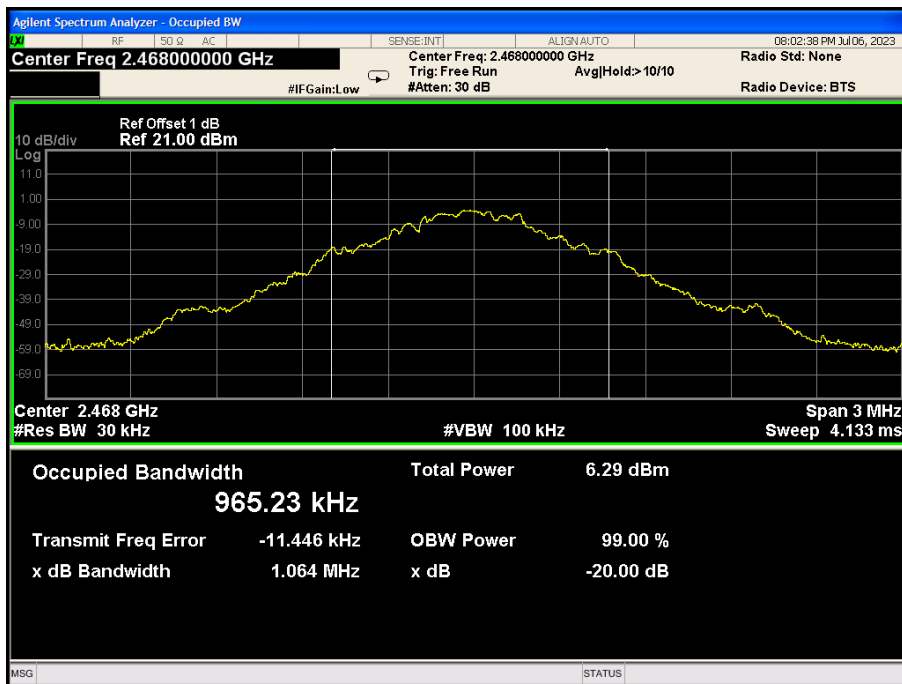

CH05: 2478.00MHz

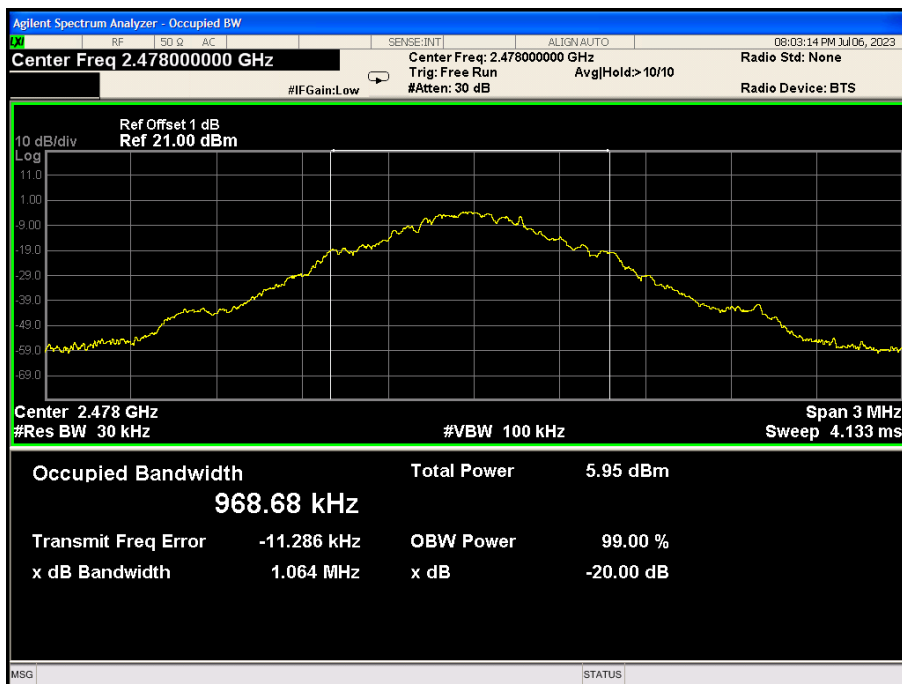

7 ANTENNA REQUIREMENT

Standard Applicable:

For intentional device, according to FCC 47 CFR Section 15.203, an intentional radiator shall be designed to ensure that no antenna other than that furnished by the responsible party shall be used with the device.

Antenna Conncted Construction

The antenna used in this product is an Internal Antenna, The directional gains of antenna used for transmitting is 0dBi.

ANTENNA:

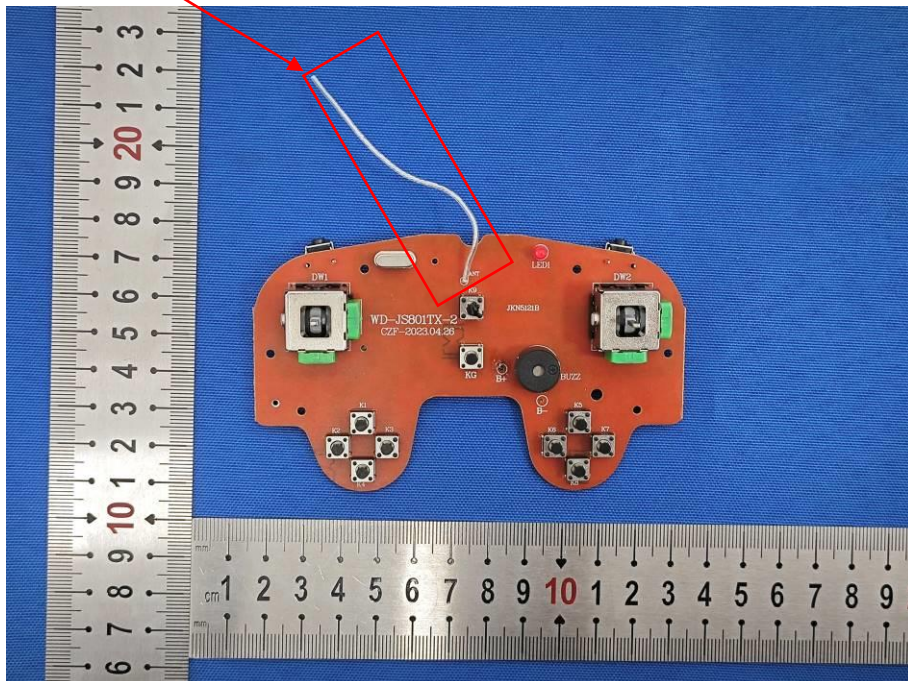

8 PHOTO OF TEST

8.1 RADIATED EMISSION

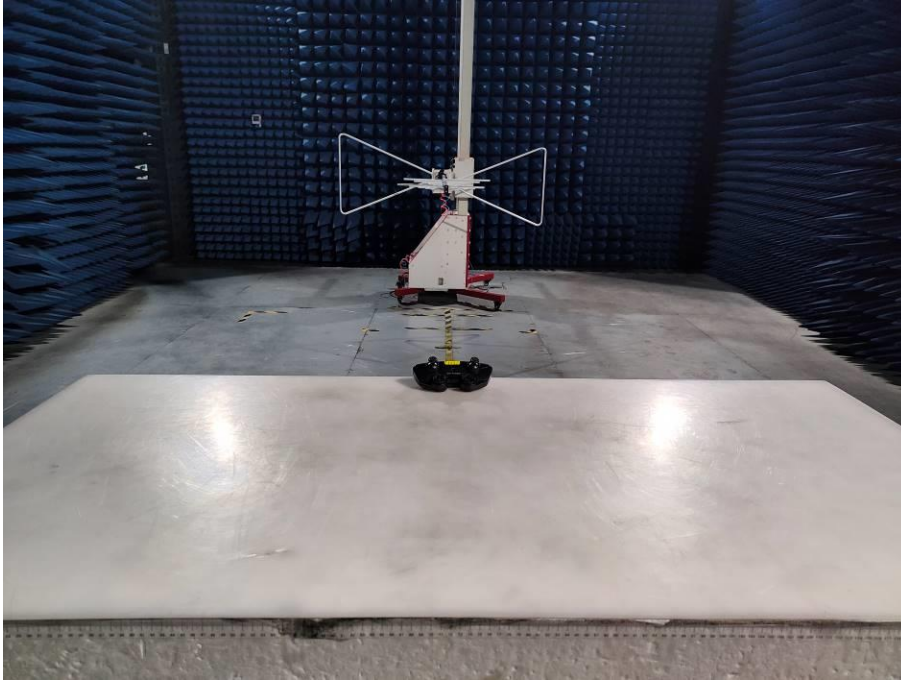

30MHz-1000MHz

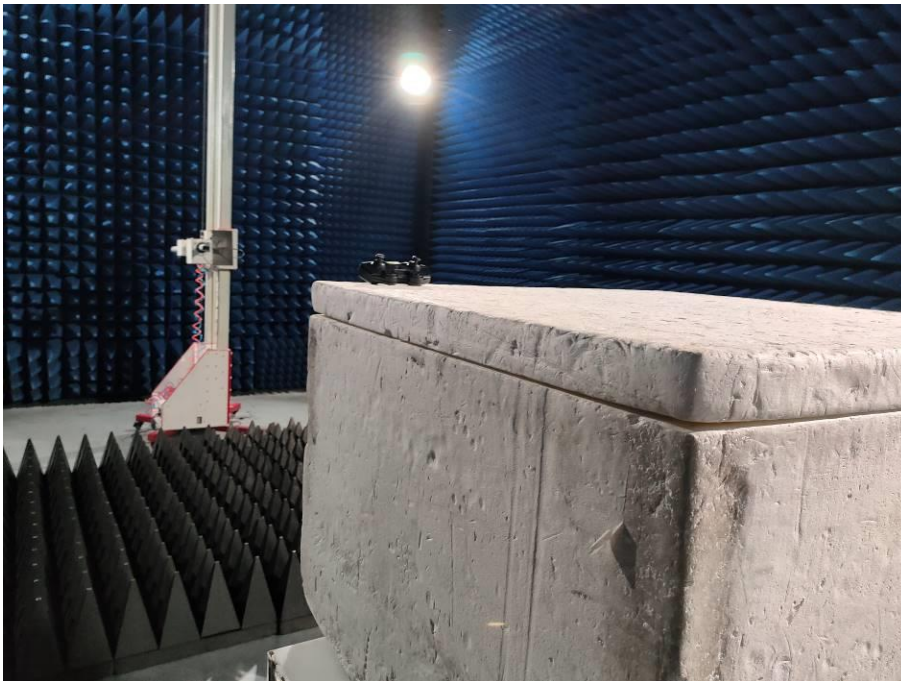

Above 1GHz

8.2 RF CONDUCTED

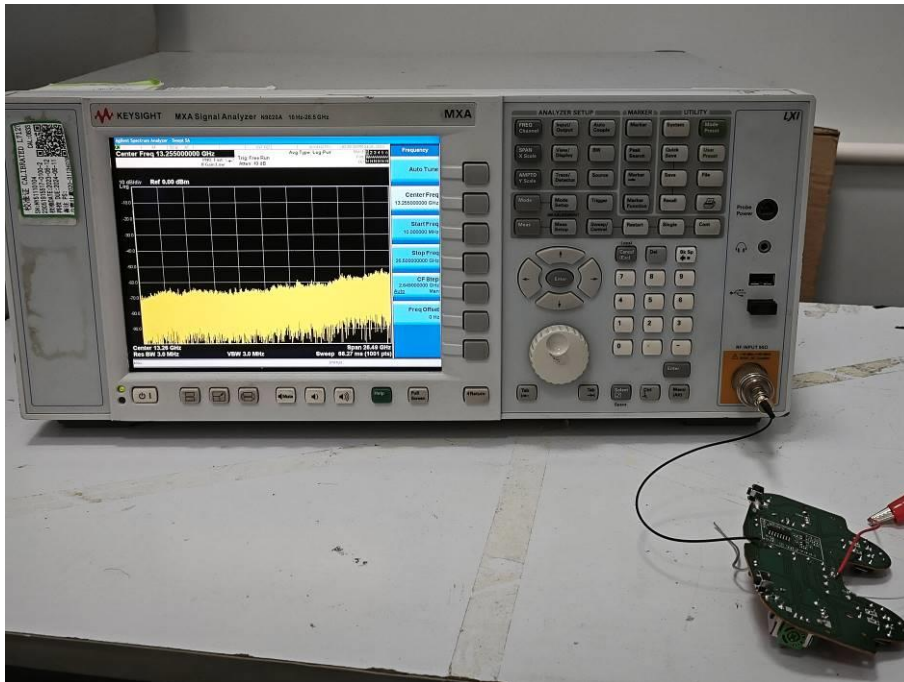

End of Report