

# X-13 Callisto

Quadcopter Drone with Wi-Fi Camera



User's Guide for Model DRW313 v3298-01

# Warnings & Precautions

## Important Safety Instructions

- Read and follow all instructions.
- Keep these instructions for future reference.
- Heed all Warnings.
- Intended for children ages 14 and higher. Adult supervision is required.
- Only use attachments/accessories specified by the manufacturer.
- Before flying, always check the body, rotors, and battery for any damage or obstructions.
- Battery should be free from cracks or swelling.
- Keep the rotors clear of any obstructions and body parts to avoid potential damage and injury.
- Manufacturer and dealer assume no liability for accidental damages from improper use or installation of parts, or from damage incurred from worn or broken parts.
- Pilots are responsible for their actions and any damage caused from improper use.
- Pilots should keep the craft in sight at all times during flight. If you lose sight of the craft at any time, power down and cease flight immediately.
- Only fly in large, open areas that are free from obstacles or potential hazards, such as trees, power lines, ceiling fans, and the like.
- Flying over bodies of water is not recommended.
- Flying at night is not recommended.
- Never try to retrieve the craft from areas you cannot safely reach, such as rooftops or trees.
- Never launch the craft from your hand.
- Never leave the craft unattended while it is powered on or while the battery is charging.

## FCC Warnings

This device complies with part 15 of the FCC Rules. Operation is subject to the following two conditions: (1) This device may not cause harmful interference, and (2) this device must accept any interference received, including interference that may cause undesired operation. Any changes or modifications to this unit not expressly approved by the party responsible for compliance could void the user's authority to operate the equipment. This equipment has been tested and found to comply with the limits for a Class B digital device, pursuant to Part 15 of the FCC Rules. These limits are designed to provide reasonable protection against harmful interference in a residential installation. This equipment generates, uses, and can radiate radio frequency energy and, if not installed and used in accordance with the instructions, may cause harmful interference to radio communications. However, there is no guarantee that interference will not occur in a particular installation. If this equipment does cause harmful interference to radio or television reception, which can be determined by turning the equipment off and on, the user is encouraged

to try to correct the interference by one or more of the following measures:

- Reorient or relocate the receiving antenna.
- Increase the separation between the equipment and receiver.
- Connect the equipment into an outlet on a circuit different from that to which the receiver is connected.
- Consult the dealer or an experienced radio/TV technician for help.

## Additional Warnings & Precautions

- **WARNING:** To reduce the risk of fire or electric shock, do not expose this apparatus to rain, moisture, dripping, or splashing.
- **CAUTION:** Use of controls or adjustments or performance of procedures other than those specified may result in personal injury.
- **WARNING:** Changes or modifications to this unit not expressly approved by the party responsible for compliance could void the user's authority to operate the equipment.
- **CAUTION:** Danger of explosion if battery is incorrectly replaced. Replace only with the same or equivalent type.
- Lithium batteries, like all rechargeable batteries, are recyclable and should be recycled or disposed of according to state and local guidelines. They should never be disposed of in normal household waste, and they should never be incinerated, as they might explode. Contact your local government for disposal or recycling practices in your area.
- **WARNING:** Shock hazard - Do Not Open.
- Battery shall not be exposed to excessive heat such as sunshine, fire, or the like.
- Keep new and used batteries away from children. If the battery compartment does not close securely, stop using the product and keep it away from children.
- If you think batteries might have been swallowed or placed inside any part of the body, seek immediate medical attention.
- Do not mix old and new batteries.
- Completely replace all old batteries with new ones.
- Do not mix alkaline, standard (carbon-zinc), or rechargeable (ni-cad, ni-mh, etc) batteries.
- Batteries should be recycled or disposed of as per state and local guidelines.

## FCC Radiation Exposure Statement

The device has been evaluated to meet general RF exposure requirement. The device can be used in portable exposure condition without restriction.

# Table of Contents

---

## **X-13 Callisto Wi-Fi Drone**

FAA Information: Flying Your Drone Under the Special Rule for Model Aircraft – 4

Features – 4

Includes – 4

Specifications – 4

Top View Diagram – 5

Front View Diagram – 6

Camera Adjustment – 6

## **Remote Control**

Functions – 7

Battery Installation – 8

## **Charging the Battery**

Information & Procedure – 9

## **Flying**

Remote Link & Calibration – 10

One Key Takeoff – 11

Flight Controls – 11

When You're Finished Flying – 11

Setting Trim & Countering Drift – 12

Remote Trim Reset – 13

Tips for Safe Operation – 14

Speed Setting – 14

Headless Mode – 14

Flips – 15

Gyroscope Recalibration – 15

## **Sky Rider Cruise App**

Free Download – 16

Connect to Wi-Fi – 16

Settings Screen – 17

Screen Controls – 18

Flight Controls – 19

Using the Remote & App Together – 20

## **Parts & Repair**

Parts Replacement – 21

Rotor Replacement – 21

## **Troubleshooting**

Troubleshooting Guide – 22

## **Customer Support**

Contact Information – 23

International Support – 23

Warranty – 23

# X-13 Callisto Wi-Fi Drone

## FAA Information: Flying Your Drone Under the Special Rule for Model Aircraft

To fly under the Special Rule for Model Aircraft you must:

- Fly for hobby or recreation ONLY
- Register your model aircraft
- Fly within visual line-of-sight
- Follow community-based safety guidelines and fly within the programming of a nationwide community-based organization
- Fly a drone under 55 lbs. unless certified by a community-based organization
- Never fly near other aircraft
- Notify the airport and air traffic control tower prior to flying within 5 miles of an airport
- Never fly near emergency response efforts

**You alone are responsible for safely and responsibly flying your drone.** For more information on FAA Rules and Guidelines for flying Unmanned Aerial Systems please visit: <http://www.faa.gov/uas/>

### Features

- 360° flips & tricks
- Vertical Take Off and Landing (VTOL)
- 6-axis gyroscope
- Altitude hold
- Headless mode
- Adjustable angle Wi-Fi camera
- 3 speeds
- Control distance: up to 328 feet
- Wi-Fi distance: up to 164 feet
- LED navigation lights
- Free Sky Rider Flight app
- Operating time: 6–8 minutes
- Charge time: approx. 90 minutes

### Includes

- USB charging cable
- 2.4GHz remote control: requires 4 AAA batteries (not included)
- Rechargeable lithium polymer battery
- Smartphone cradle
- 4 replacement rotors
- Screwdriver
- User's Guide

### Specifications

- Dimensions: 300x220x75mm/11.81x8.66x2.95in (LWH)
- Weight: 158.75g/5.6oz/0.35lb

# Overview

## Top View Diagram

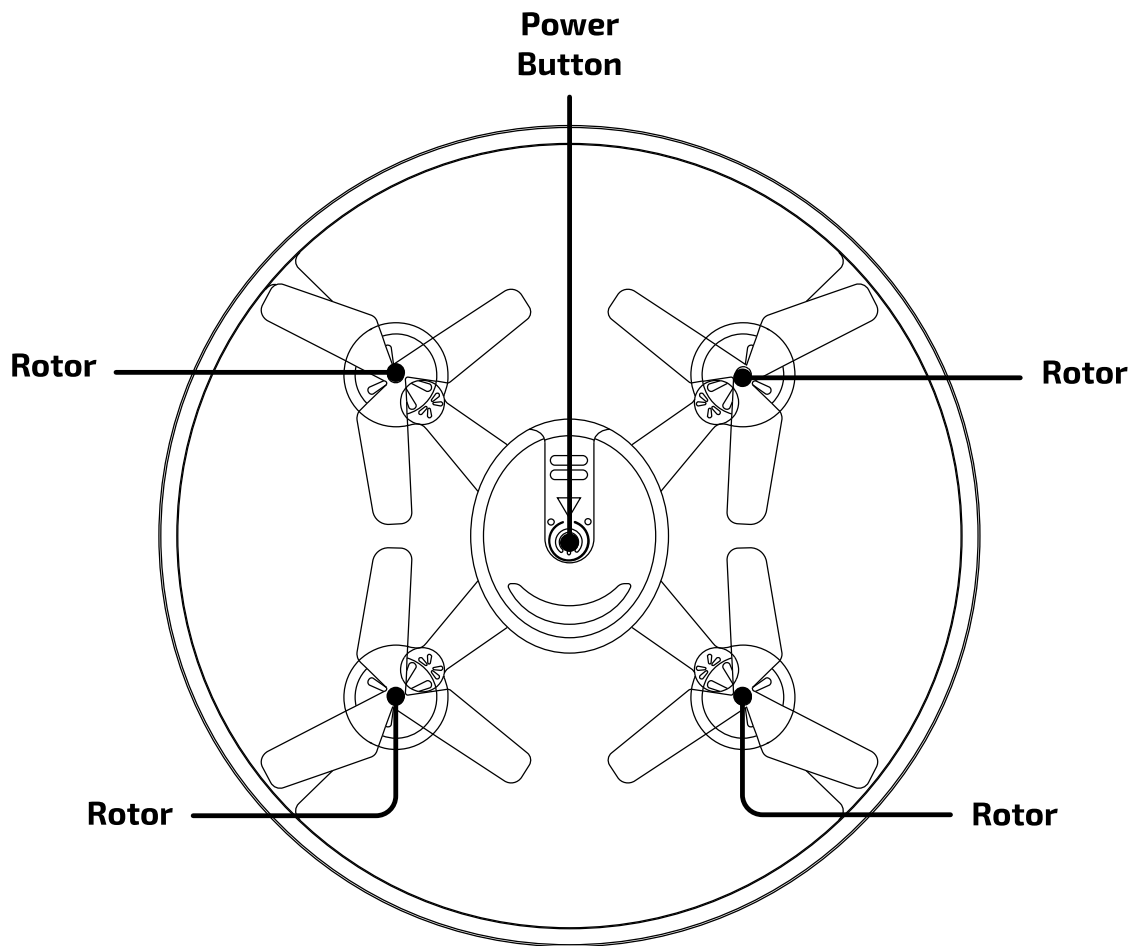

# Overview

## Front View Diagram

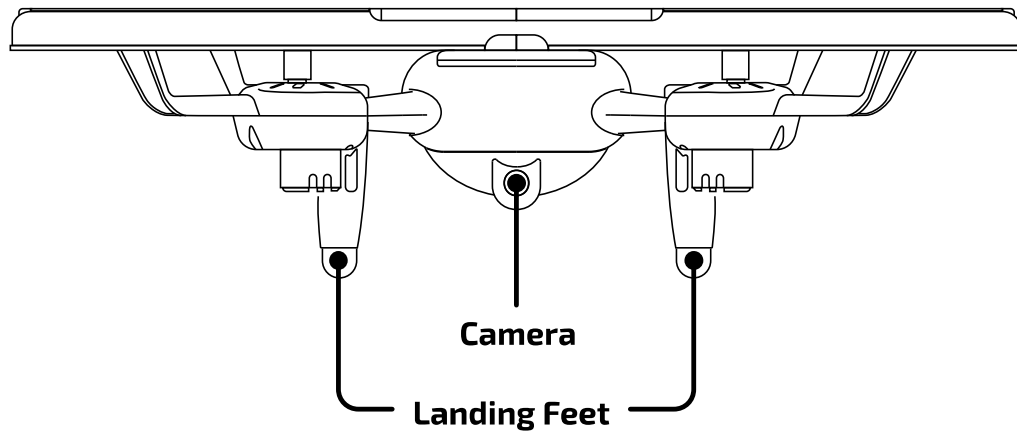

## Camera Adjustment

Rotate the camera lens by hand to change the viewing angle.

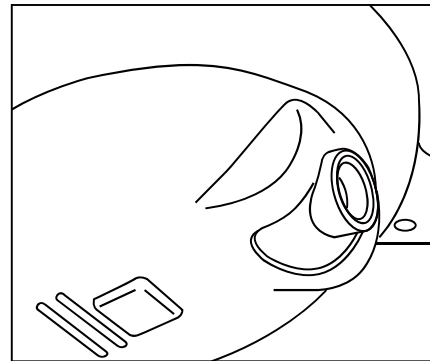
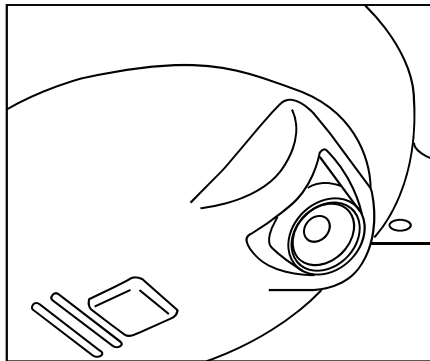

# Remote Control

## Functions

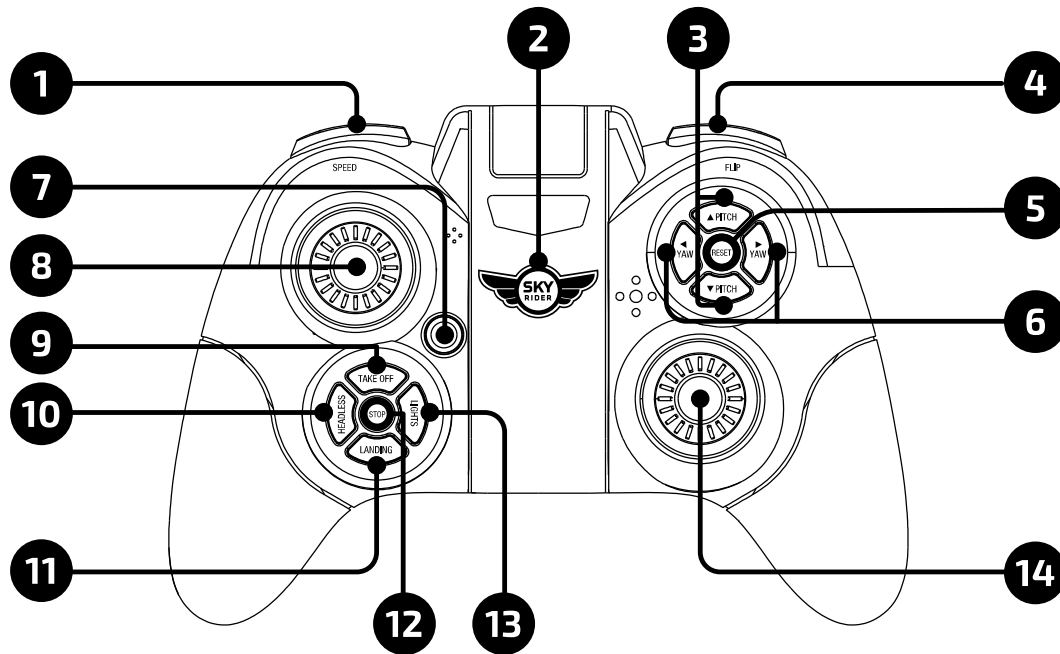

- 1. Speed Setting**  
Press to set low/med/high speed.  
Remote will chime to indicate setting.
- 2. Phone Holder**
- 3. Pitch (Front/Back) Trim**
- 4. Flip**  
Press to perform a flip.
- 5. Reset**
- 6. Yaw (Left/Right) Trim**
- 7. Power Button**
- 8. Left Control Stick**  
*Up:* push forward  
*Spin Counterclockwise:* push left  
*Down:* push backward  
*Spin Clockwise:* push right
- 9. One Key Takeoff**  
Press once after unlocking drone to takeoff.
- 10. Headless**  
Press once to enter headless mode.
- 11. One Key Landing**  
Press during flight to slowly land drone.
- 12. Emergency Stop**  
Press to activate emergency landing.
- 13. LED Lights**  
Press to turn LED lights on/off.
- 14. Right Control Stick**  
*Forward:* push forward  
*Left:* push left  
*Backward:* push backward  
*Right:* push right

# Remote Control

## Battery Installation

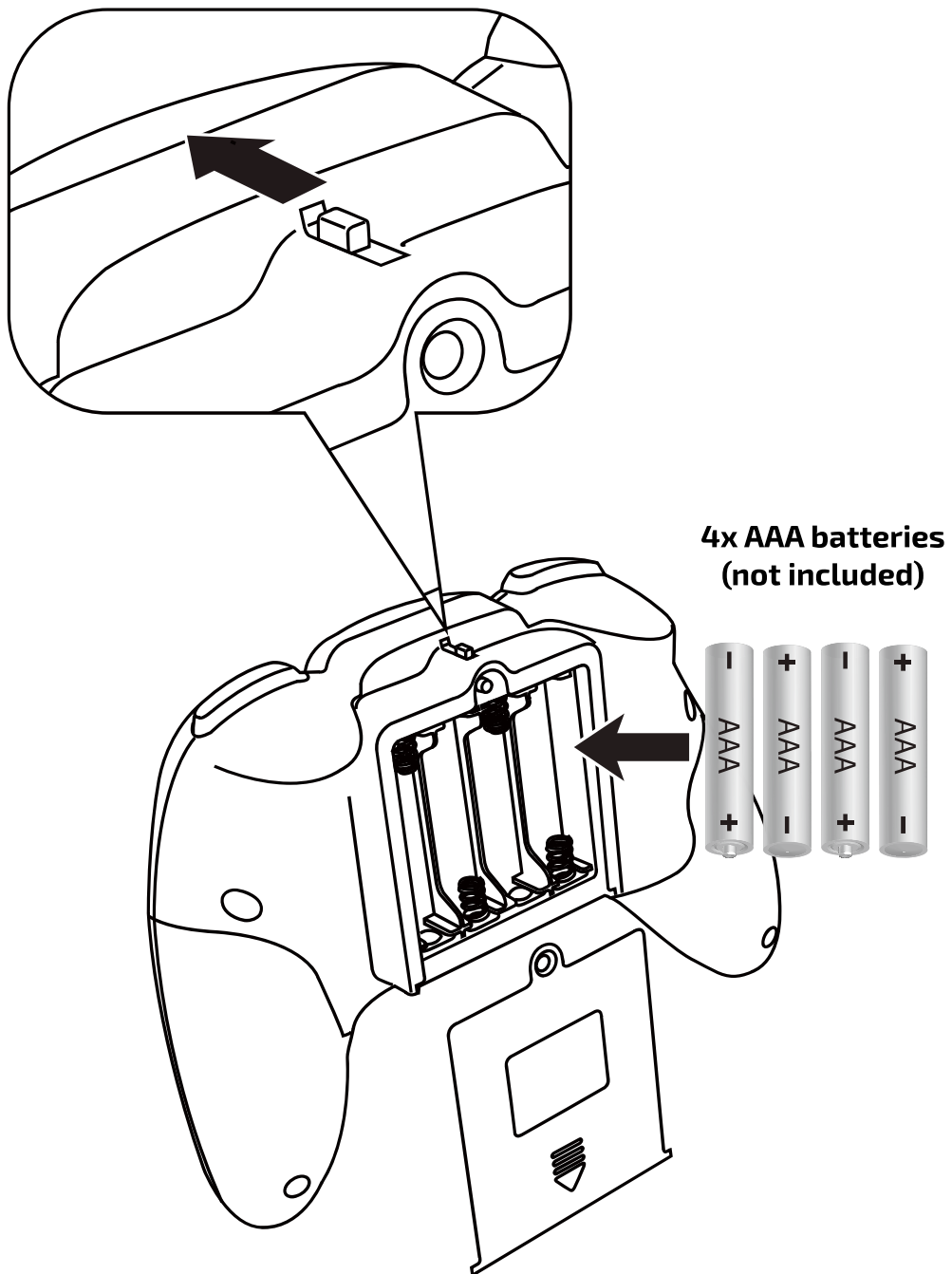



# Charging the Battery

## Information & Procedure

The drone's battery must be charged before it can be flown. To avoid risk of injury or damage, **be sure the craft and remote control are both powered OFF and remove the battery from the drone when charging.** Charging time is approximately 90 minutes. Charge fully before use for best performance.

Connect the USB charging cable (included) to the USB port of a powered-on computer or USB power adapter (not included), then connect the charging plug to the battery plug.

**While charging,** the charger will display a red light.

**When charging is complete,** the light will turn OFF.

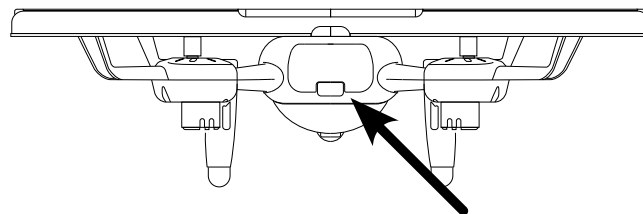

Battery compartment  
(back view of drone)

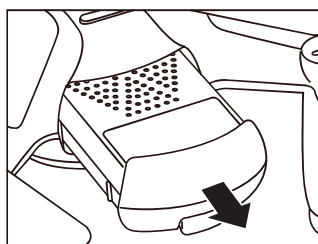

Slide battery out.

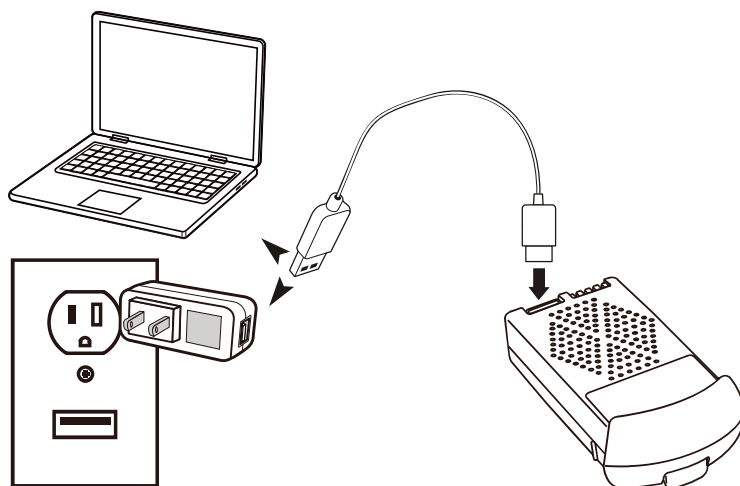

# Flying

## Remote Link & Calibration

Before flying, the drone and the remote must be linked together, the gyroscopes on the drone must be calibrated, and the drone must be unlocked.

**Begin with the battery installed, the battery compartment closed, and the drone and remote powered OFF.**

### Step 1

Power ON the drone and place it on a flat surface. This is necessary for the drone's gyroscopes to properly align. The lights on the drone will flash as it searches for a signal from the remote.

**Be sure you and the drone are facing the same forward direction; this will help with orientation while flying.**

### Step 2

Power ON the remote. The light on the remote will blink as it searches for the signal from the drone. Push the **Left Control Stick** fully up, then pull the stick fully down. The lights on the drone and the remote will turn steady when the remote and the drone have linked.

### Step 3

Push the **Both Control Sticks** down and to the right at the same time, as seen in figure 3. The gyroscope is now calibrated.

### Step 4

Push the **Left Control Stick** down and to the left and push the **Right Control Stick** down and to the right at the same time, as seen in figure 4. The drone is now unlocked and ready to fly. Push the **Left Control Stick** up to take off.

figure 1



Front

figure 2

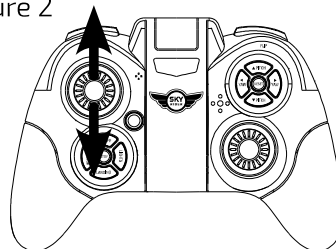

figure 3

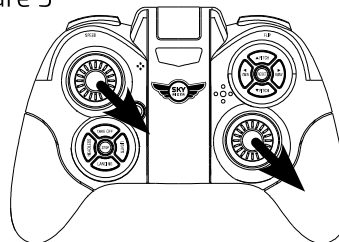
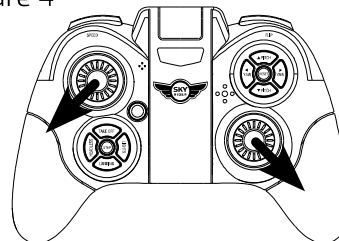
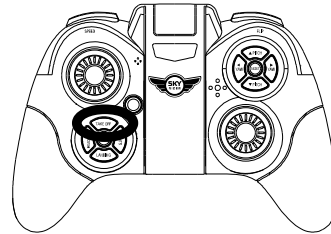

figure 4



## One Key Takeoff

After completing step 3, you can press the **One Key Takeoff** button to unlock the drone and take off.



## Flight Controls

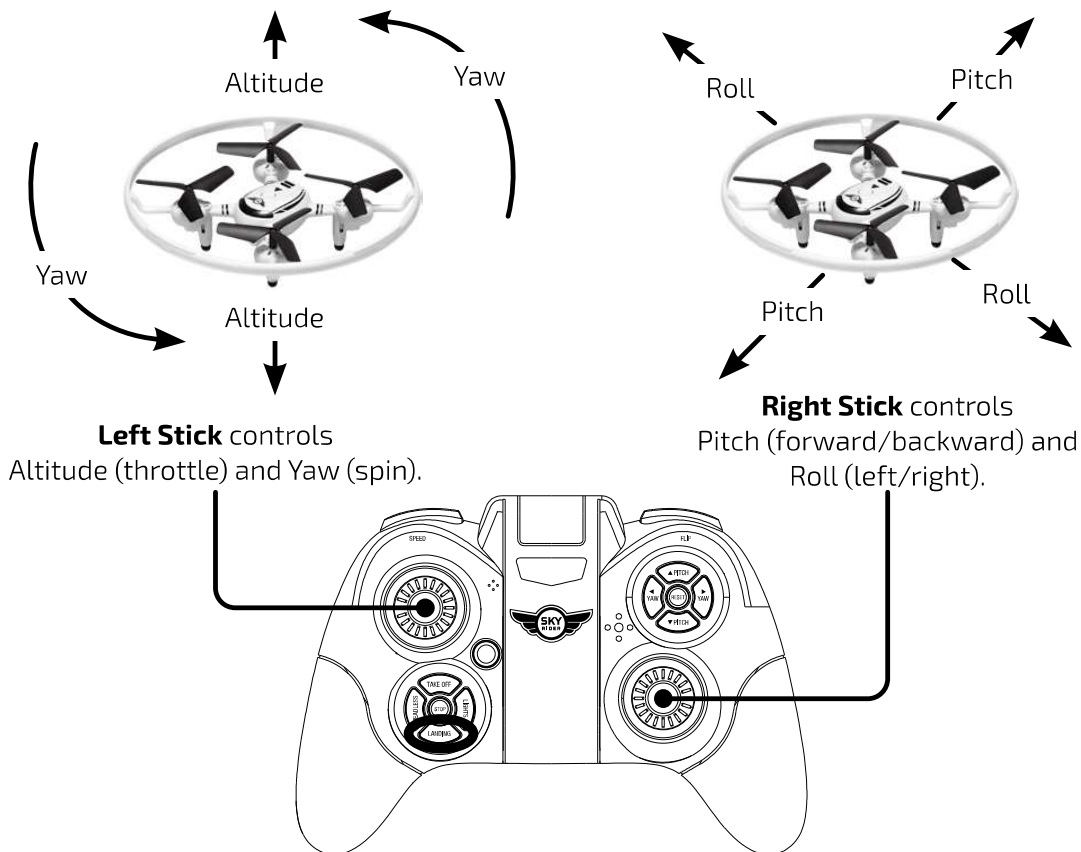

**Left Stick** controls  
Altitude (throttle) and Yaw (spin).

**Right Stick** controls  
Pitch (forward/backward) and  
Roll (left/right).

## When You're Finished Flying

Press the **Landing** button during flight to slowly land the drone.

After landing, keep the **Left Control Stick** pulled down and wait for the rotors to stop spinning. **Power OFF the remote BEFORE powering OFF the drone.** This will ensure that no signals are accidentally sent by the remote, reducing the chance of injury. After this is done, it is safe to pick up and power OFF the drone.

# Flying

## Setting Trim & Countering Drift

Even after the drone is calibrated, it may start to drift while airborne. Adjusting the trim will help counter this effect and allow better control of the drone.

To avoid potential damage, adjust the trim while attempting a stable hover. Try to avoid making any exaggerated movements with the flight controls and adjust one trim setting at a time to avoid confusion.

**Note:** Adjusting the trim will help with drift but it will not entirely eliminate it. Air currents and other factors may still cause slight drift while airborne. Adjusting the trim is meant to correct obvious drift that makes the craft difficult to control.

Drone spins right.



Adjust **Left Yaw Trim**.

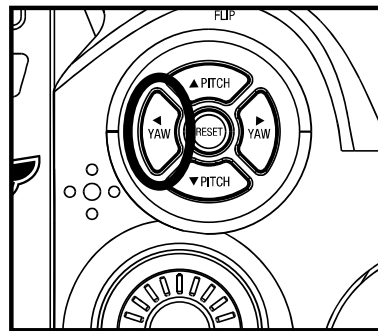

Drone spins left.



Adjust **Right Yaw Trim**.

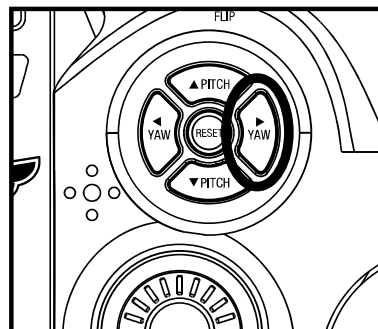

Drone drifts forward



Adjust **Down Pitch Trim**.

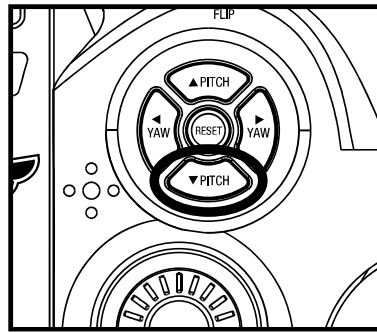

Drone drifts backward.



Adjust **Up Pitch Trim**.

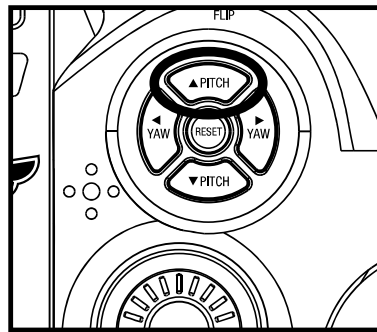

## Remote Trim Reset

If you are still having difficulty flying, it may help to reset the trim adjustments on the remote. Do not attempt to do this while flying, safely land the craft first.

Press the **Reset** button on the remote. The remote will chime once to indicate that the trim has been reset to default.

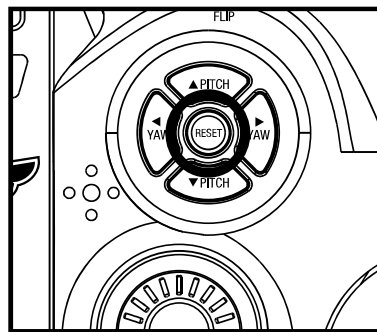

# Flying

## Tips for Safe Operation

- It is recommended to only fly in large, open spaces that are free of obstacles like power lines, trees, ceiling fans, etc.
- When flying indoors avoid walls and ceilings, as the drone may be drawn towards them if closer than 2-3 feet.
- Stand behind the drone when first taking off, so that you and the drone are facing the same "forward" direction. This will help with orientation when the drone is airborne.
- Novice pilots should move the controls slowly and deliberately to get used to the drone's flying characteristics. Try using one control at a time.
- Practice basic flight operations like take off, hovering, and landing.
- If you get into trouble or if anything obstructs the rotors, cut power immediately and safely clear the obstruction. Check for possible damage before flying again.

## Speed Setting

Press the **Speed** button on the remote to change the drone's speed setting.

- **Low:** Provides smooth and predictable control of the drone. The remote will chime once to indicate the Low speed setting.
- **Medium:** The drone will move and respond faster to all control inputs. The remote will chime twice to indicate the Medium speed setting.
- **High:** Highest setting for maximum performance. The remote will chime three times to indicate the High speed setting.

## Headless Mode

Before using Headless Mode be sure you and the drone are facing the same "forward" direction, otherwise the drone will not fly correctly. **To activate Headless Mode, press the Headless button** on the remote control. The LED lights will slowly flash while Headless Mode is ON. Press the button again to deactivate Headless Mode.

While Headless Mode is active the drone will fly in whatever direction the **Right Control Stick** is moved, regardless of where the front of the craft is pointing. For example, if the front of the drone was pointed straight ahead but is now pointed right 90°, when you push forward on the stick the drone will fly forwards as if it were still pointed straight ahead. This can be useful if you become disoriented while flying and cannot visually determine which direction the craft is facing.

## Flips

Before attempting a flip, be sure that there is enough clear space around the drone, ideally 9-10 ft. in all directions. It is not recommended to attempt to flip around or through any obstacles, as this may result in unintended damage.

Press the **Flip button** to activate Flip Mode, then move the **Right Control Stick** in any direction and the drone will perform a flip in the same direction. Press the **Flip button** again to deactivate without performing a flip.

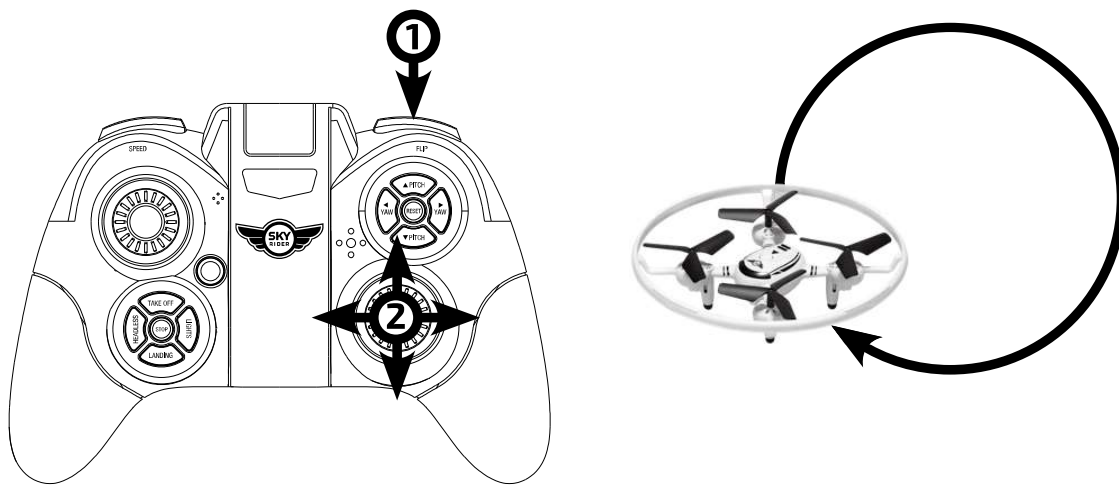

## Gyroscope Recalibration

If the drone is having difficulty flying, its gyroscopes may need to be recalibrated. Do not attempt to do this while flying. Land the drone first, then place it on a flat surface.

*Note: The drone and the remote should already be linked together.*

Push **Both Control Sticks** down and to the right at the same time. When the LED lights have stopped blinking and turn solid the recalibration is complete.

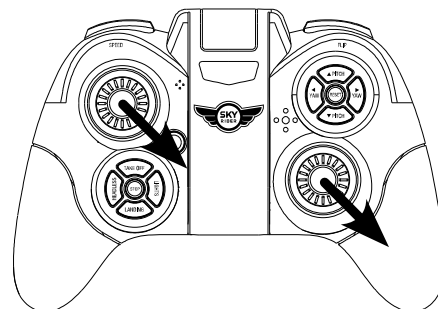

# Sky Rider Cruise App

The Sky Rider Cruise app will display the image from the drone's camera on your smartphone's screen, allowing you to capture images and video of your flights. Connect your smartphone to the drone's Wi-Fi signal and start flying!

## Free Download

Scan the appropriate QR code with your smartphone or search for "**Sky Rider Cruise**" in the Apple App Store or Google Play Store.

## Connect to Wi-Fi

**NOTE:** Wi-Fi control may be interrupted by interference from other nearby Wi-Fi equipment.

Before beginning, make sure your phone's Wi-Fi is enabled and the craft is powered ON.

- From your smartphone, open the Wi-Fi settings menu, then search for and select **Sky Rider Cruise-xxxx** to connect to the craft.
- Once connected, open the app. You will see the **Home Screen** (image below). From here you can adjust settings and start using the app.

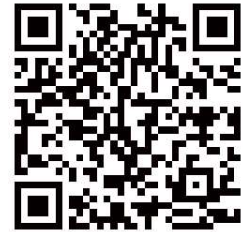

Android



Apple



1. Start
2. FAQ
3. Settings



# Sky Rider Cruise App

## Settings Screen

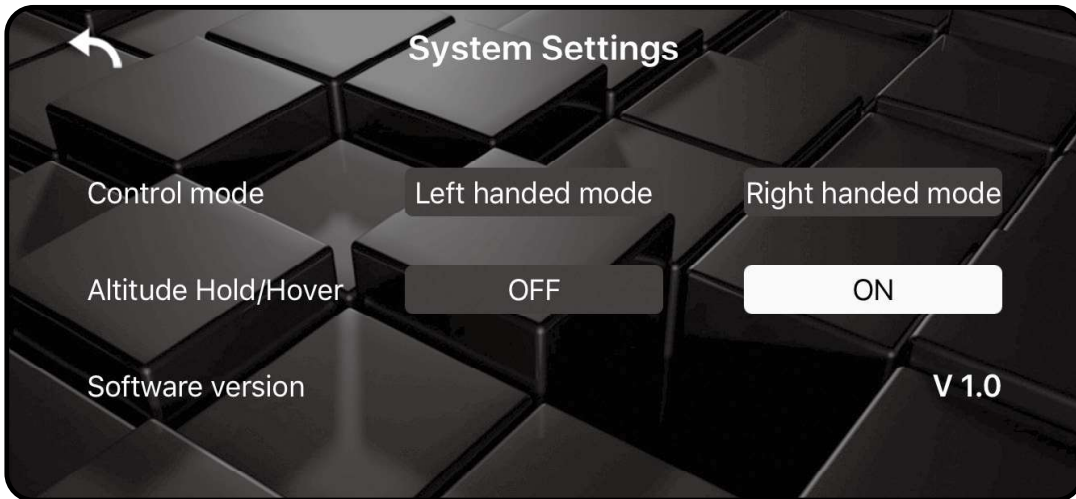

**Altitude Hold/Hover-** This setting will lock the drone at the altitude it is currently at.

**Right Hand Mode -** Reverses the locations of the Left and Right flight controls on the screen.

# Sky Rider Cruise App

## Screen Controls

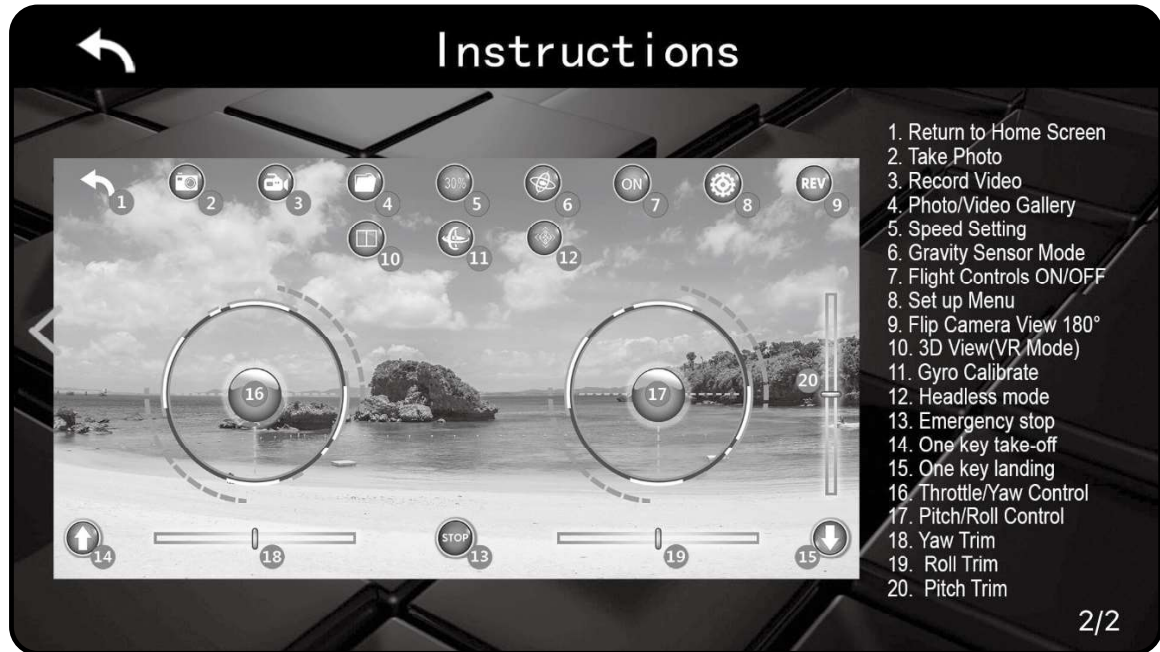

**Gravity Sensor Mode** uses the G-Sensor in your phone to control the drone. Tilt the phone forward, back, left, and right to control the **pitch and roll** of the drone. **Throttle and yaw** are still manually controlled from the **Left Control Stick**.

### Camera & Video

Use the **Photo and Video buttons** to document your flight. Images and video are saved to your phone and can be viewed later by pressing the **Gallery button**.

# Sky Rider Cruise App

## Flight Controls



# Sky Rider Flight App

## Using the Remote & App Together

It can be easier to capture photos and video by using the remote to fly the drone and using the app in a viewing only method. Use the app and the remote together by attaching the smartphone holder (included) to the remote and placing your phone in the holder.

Follow the steps below to connect to the remote and the app in the proper sequence.

- **First, connect the remote to the drone like normal.** Connecting the remote first overrides any control signals from the app.
- Next, use your phone to connect to the drone's Wi-Fi. Open the app and go to the Flight Screen. Leave the Flight Controls off for the best view from the drone's camera.
- **Use the controls on the remote** to fly the drone while the Wi-Fi camera streams to your phone.
- When you're finished flying, power down the remote and drone like normal.

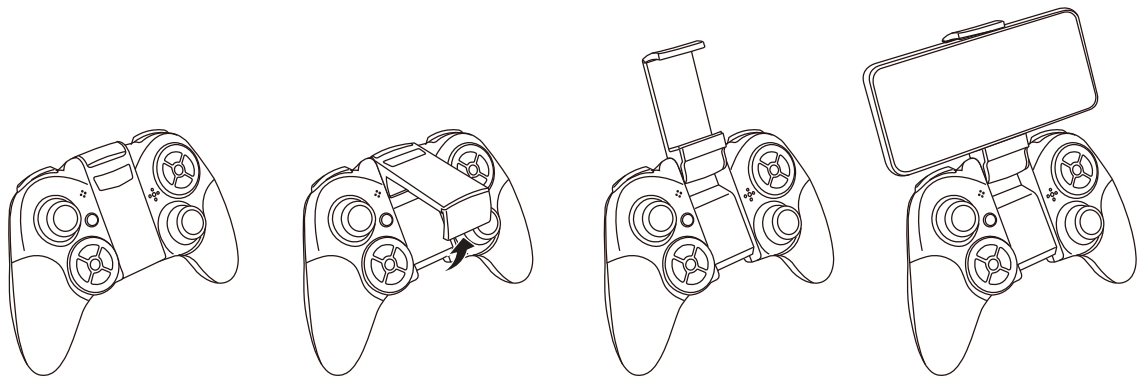

# Parts & Repair

**REMINDER: Pilots are responsible for any damage caused by improper use.**

## Parts Replacement

Standard parts such as extra batteries and remotes are available online for purchase when in stock. However, any non-standard parts such as cameras, screws, bodies, etc. can be ordered by placing an inquiry with our parts department at: [partsinfo@dpiinc.com](mailto:partsinfo@dpiinc.com).

## Rotor Replacement

The drone comes with replacement rotors if the originals are broken or badly damaged. Use the included screwdriver to remove the rotor retaining screw that holds the rotor to the motor shaft. Once the retaining screw is out, pull upwards on the rotor to remove it from the motor shaft. Installation of the new rotor is the reverse of the removal process. Be sure to tighten the rotor retaining screw firmly, but do not over tighten.

**It is extremely important to use the correct rotor (A or B) for replacement.** Using the incorrect rotor will make the drone impossible to control. The marking can be found on the rotor near the shaft.

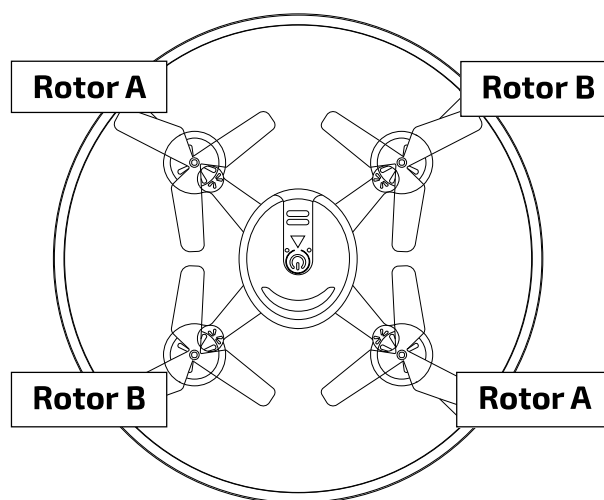
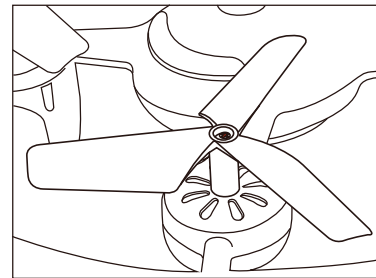
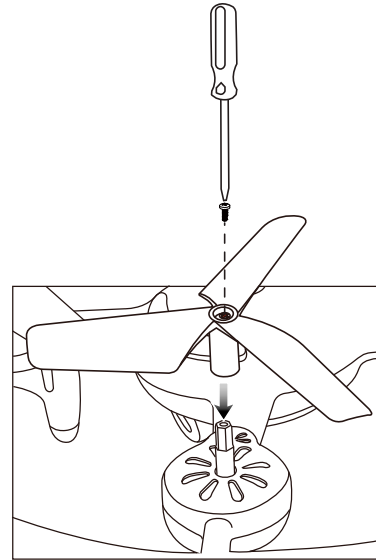

# Troubleshooting

## Troubleshooting Guide

PROBLEM	POSSIBLE CAUSES	SOLUTION
<b>Drone does not respond to controls.</b>	<ul style="list-style-type: none"><li>• No power to remote or drone.</li><li>• Poor contact between power plugs.</li><li>• Drone is out of range.</li></ul>	<ul style="list-style-type: none"><li>• Check remote batteries, replace if needed.</li><li>• Check drone battery, make sure it is fully charged.</li><li>• Be sure the power plugs are firmly connected.</li><li>• Be sure the remote has an unobstructed line of sight to the drone.</li><li>• Remain within the remote's 328ft. range.</li></ul>
<b>Drone is difficult to control or flies erratically.</b>	<ul style="list-style-type: none"><li>• Gyroscopes may be misaligned.</li></ul>	<ul style="list-style-type: none"><li>• Power OFF remote and drone and reconnect (see pg. 15).</li></ul>
<b>Drone drifts while in flight.</b>	<ul style="list-style-type: none"><li>• Trim not set or needs adjustment.</li></ul>	<ul style="list-style-type: none"><li>• Adjust trim settings (see pg. 12).</li></ul>
<b>Drone suffers from mechanical trouble.</b>	<ul style="list-style-type: none"><li>• Damage to body, rotors or other major components.</li></ul>	<ul style="list-style-type: none"><li>• Repair or replace parts as needed.</li></ul>
<b>LED lights ON but drone does not respond to controls.</b>	<ul style="list-style-type: none"><li>• Low battery power.</li></ul>	<ul style="list-style-type: none"><li>• Recharge the battery.</li></ul>

# Customer Support

## Contact Information

Website: [www.gpx.com](http://www.gpx.com)

Email Support: [proinfo@dpiinc.com](mailto:proinfo@dpiinc.com)

Email Parts: [partsinfo@dpiinc.com](mailto:partsinfo@dpiinc.com)

Phone Support: **1-888-999-4215**

## Warranty

See included 30 Day Warranty for warranty information. Warranty and the most up-to-date version of this User's Guide can also be found at: [www.gpx.com](http://www.gpx.com)

## International Support

To download this User's Guide in English, Spanish, and French, or to get answers to frequently asked questions, visit the support section at: [www.gpx.com](http://www.gpx.com)

Para descargar este Manual del Usuario en inglés, español y francés, o para obtener respuestas a preguntas frecuentes, visite la sección de apoyo en: [www.gpx.com](http://www.gpx.com)

Pour télécharger ce guide de l'utilisateur en anglais, espagnol ou français, ou pour obtenir des réponses à des questions fréquemment posées, consultez la rubrique d'assistance sur: [www.gpx.com](http://www.gpx.com)



***Protect for Today  
Sustain for Tomorrow***

Copyright © 2024 Digital Products International (DPI, Inc.) All other trademarks appearing herein are the property of their respective owners. Specifications are subject to change without notice.

