

Produkte
 Products

Prüfbericht - Nr.: 14046732 001		Seite 1 von 17			
<i>Test Report No.:</i>		<i>Page 1 of 17</i>			
Auftraggeber: <i>Client:</i>	Sanwa Global Limited Unit G&H, 7/F, Block 1, Kwai Tak Industrial Centre 15 - 33 Kwai Tak Street, Kwai Chung, Hong Kong				
Gegenstand der Prüfung: <i>Test Item:</i>	Bluetooth Headset				
Bezeichnung: <i>Identification:</i>	Aria Two	Serien-Nr.: <i>Serial No.:</i>	Engineering sample		
Wareneingangs-Nr.: <i>Receipt No.:</i>	A000451202-001 A000469786-006	Eingangsdatum: <i>Date of Receipt:</i>	04.11.2016 06.12.2016		
Prüfört: <i>Testing Location:</i>	TÜV Rheinland Hong Kong Ltd. 3-4, 11/F., Fou Wah Industrial Building, 10-16 Pun Shan Street, Tsuen Wan, N.T., Hong Kong Hong Kong Productivity Council HKPC Building, 78 Tat Chee Avenue, Kowloon, Hong Kong				
Zustand des Prüfgegenstandes bei Anlieferung: <i>Condition of test item at delivery:</i>	Test samples are not damaged and suitable for testing.				
Prüfgrundlage: <i>Test Specification:</i>	FCC Part 15 Subpart C ANSI C63.10-2013				
Prüfergebnis: <i>Test Results:</i>	Das vorstehend beschriebene Gerät wurde geprüft und entspricht oben genannter Prüfgrundlage. The above mentioned product was tested and passed .				
Prüflaboratorium: <i>Testing Laboratory:</i>	TÜV Rheinland Hong Kong Ltd. 3-4, 11/F., Fou Wah Industrial Building, 10-16 Pun Shan Street, Tsuen Wan, N.T., Hong Kong				
geprüft/ tested by:	kontrolliert/ reviewed by:				
04.01.2017	David Cheng Test Engineer		04.01.2017	Benny Lau Senior Project Manager	
Datum <i>Date</i>	Name/Stellung <i>Name/Position</i>	Unterschrift <i>Signature</i>	Datum <i>Date</i>	Name/Stellung <i>Name/Position</i>	Unterschrift <i>Signature</i>
Sonstiges: <i>Other Aspects</i>	FCC ID: 2AGYNBT1502				
Abkürzungen:	P(ass) = entspricht Prüfgrundlage F(ail) = entspricht nicht Prüfgrundlage N/A = nicht anwendbar N/T = nicht getestet	Abbreviations:	P(ass) = passed F(ail) = failed N/A = not applicable N/T = not tested		
<p>Dieser Prüfbericht bezieht sich nur auf das o.g. Prüfmuster und darf ohne Genehmigung der Prüfstelle nicht auszugsweise vervielfältigt werden. Dieser Bericht berechtigt nicht zur Verwendung eines Prüfzeichens.</p> <p><i>This test report relates to the a. m. test sample. Without permission of the test center this test report is not permitted to be duplicated in extracts. This test report does not entitle to carry any safety mark on this or similar products.</i></p>					

Table of Content

	Page
Cover Page	1
Table of Content	2
Product information	4
Manufacturers declarations	4
Product function and intended use	4
Submitted documents.....	4
Independent Operation Modes	4
Related Submittal(s) Grants	5
Remark	5
Test Set-up and Operation Mode	6
Principle of Configuration Selection	6
Test Operation and Test Software	6
Special Accessories and Auxiliary Equipment.....	6
Countermeasures to achieve EMC Compliance.....	6
Test Methodology	7
Radiated Emission	7
Field Strength Calculation.....	7
Test Setup Diagram	8
List of Test and Measurement Instruments	10
Measurement Uncertainty	11
Results FCC Part 15 – Subpart C	12
FCC 15.203 – Antenna Requirement 1.....	Pass..... 12
FCC 15.204 – Antenna Requirement 2.....	N/A..... 12
FCC 15.207 – Disturbance Voltage on AC Mains	N/A..... 12
FCC 15.247(b)(1) – Peak Output Power.....	Pass..... 12
FCC 15.247(a) – 20 dB Bandwidth	Pass..... 13
FCC 15.247(a)(1) – Carrier Frequency Separation.....	Pass..... 13
FCC 15.247 (a)(1)(iii) – Number of hopping channels.....	Pass..... 14
FCC 15.247 (a)(1)(iii) – Time of Occupancy (Dwell Time)	Pass..... 14
FCC 15.247 (a) – Hopping Sequence.....	Pass..... 15

FCC 15.247 (a) – Equal Hopping Frequency Use Pass..... 15

FCC 15.247 (a) – Receiver Input Bandwidth Pass..... 15

FCC 15.247 (a) – Receiver Hopping Capability..... Pass..... 15

FCC 15.247 (d) – Spurious Conducted Emissions..... Pass..... 16

FCC 15.205 – Radiated Emissions in Restricted Frequency Bands..... Pass..... 16

Appendix 1 – Test protocols 19 pages

Appendix 2 – Test setup 3 pages

Appendix 3 – EUT External Photos 3 pages

Appendix 4 – EUT Internal Photos 3 pages

Appendix 5 – RF exposure information 2 pages

Product information

Manufacturers declarations

	Transmitter
Operating frequency range	2402 - 2480 MHz
Type of modulation	GFSK; Pi/4 DQPSK; 8 DPSK
Number of channels	79
Channel separation	1 MHz
Type of antenna	Integral Chip Antenna
Antenna gain (dBi)	3.09 dBi
Power level	fix
Type of equipment	stand alone radio device
Connection to public utility power line	No
Nominal voltage	3.7VDC
Independent Operation Modes	Transmitting

Product function and intended use

The Equipment Under Test (EUT) is a Bluetooth wireless headset which connect to Bluetooth enabled audio source to receive audio signal.

There are 2 headsets in the system, a left and a right earphone. As declared by the manufacturer, the left and the right earphone are identical in circuit design, PCB layouts and electronic components used. Due to the equivalence of the headset, only right side headset were performed testing.

The Bluetooth function cannot be operated during charging.

FCC ID: 2AGYNBT1502

Models	Product description
Aria Two	Bluetooth Headset

Submitted documents

Circuit Diagram
 Block Diagram
 Technical Description
 Bill of material
 User manual
 Label

Independent Operation Modes

The basic operation modes are:

- Transmitting mode.-

For further information refer to User Manual

Related Submittal(s) Grants

This is a single application for certification of the Bluetooth transmitter.
Others digital function which is independent from the transmitter is authorized under verification procedure (refer to test report 14046733 001 issued by TÜV Rheinland HK Ltd on 04.01.2017)

Remark

The test results in this test report are only relevant to the tested sample and does not involve any assessment in the production.

Test Set-up and Operation Mode

Principle of Configuration Selection

Emission: The equipment under test (EUT) was configured to measure its highest possible radiation level. The test modes were adapted accordingly in reference to the instructions for use.

Test Operation and Test Software

Test operation should refer to test methodology.

- During test, Channel & Power Controlling Software provided by the customer was used to control the operating channel as well as the output power level. The RF output power was selected according to the instruction given by the manufacturer. The setting of the RF output power expected by the customer shall be fixed on the firmware of the final end product.

Special Accessories and Auxiliary Equipment

- Nil

Countermeasures to achieve EMC Compliance

- Nil

Test Methodology

Radiated Emission

The radiated emission measurements of the transmitter part were performed according to the procedures in ANSI C63.10-2013.

For measurement below 1GHz - the equipment under test (EUT) was placed at the middle of the 80 cm height turntable. For measurement above 1GHz - the EUT was placed at the middle of the 1.5 m height turntable and RF absorbing material was placed on ground plane between turntable and measuring antenna. During the testing, the EUT was operated standalone and arranged for maximum emissions. The EUT was tested in three orthogonal planes.

The investigation is performed with the EUT rotated 360°, the antenna height scanned between 1m and 4m, and the antenna rotated to repeat the measurements for both the horizontal and vertical antenna polarizations. Repeat the measurement steps until the maximum emissions were obtained.

All radiated tests were performed at an antenna to EUT with 3 meters distance, unless stated otherwise in particular parts of this test report.

Field Strength Calculation

The field strength at 3 m was established by adding the meter reading of the spectrum analyzer to the factors associated with antenna correction factor, cable loss, preamplifiers and filter attenuation.

The equation is expressed as follow:

$$FS = R + AF + CF + FA - PA$$

Where FS = Field Strength in dBuV/m at 3 meters.
R = Reading of Spectrum Analyzer in dBuV.
AF = Antenna Factor in dB.
CF = Cable Attenuation Factor in dB.
FA = Filter Attenuation Factor in dB.
PA = Preamplifier Factor in dB.

FA and PA are only be used for the measuring frequency above 1 GHz.

Test Setup Diagram

Diagram of Measurement Configuration for Radiation Test

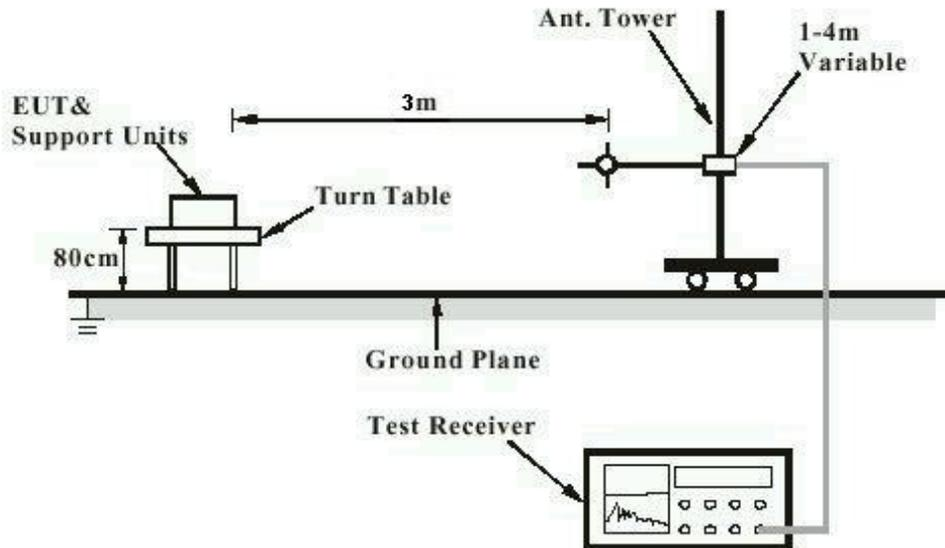

Note: Measurements above 1 GHz are done with a table height of 1.5m. In addition, there is RF absorbing material on the floor of the test site for above 1GHz measurement.

Diagram of Measurement Equipment Configuration for Mains Conduction Measurement (if applicable)

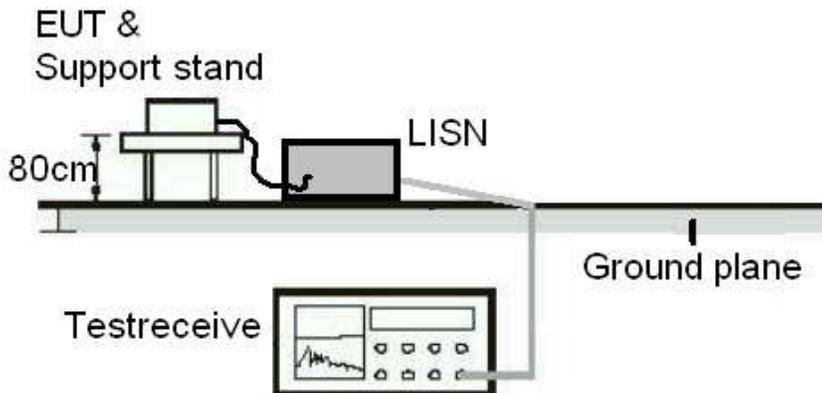
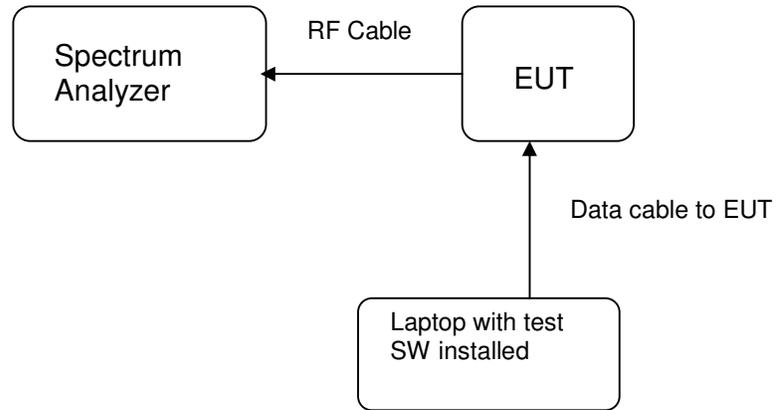

Diagram of Equipment Configuration for Antenna-port Conducted Measurement (if applicable)



List of Test and Measurement Instruments

Hong Kong Productivity Council (FCC Registration number: 90656)

Radiated Emission

Equipment	Manufacturer	Type	Cal. Date	Due Date
Semi-anechoic Chamber	Frankonia	Nil	25-Apr-16	25-Apr-17
New Fully Anchoic Chamber	TDK	N/A	26-Jul-16	26-Jul-17
Cable	Hubersuhner	SUCOFLEX 104	1-Sep-15	1-Sep-17
Test Receiver	R & S	ESU26	1-Sep-15	1-Sep-17
Bi-conical Antenna	R & S	HK116	10-Jun-16	10-Jun-18
Log Periodic Antenna	R & S	HL223	18-Jul-16	18-Jul-18
Coaxial cable	Harbour	LL335	28-Oct-15	28-Oct-17
Microwave amplifier 0.5-26.5GHz, 25dB gain	HP	83017A	26-Aug-15	26-Aug-17
High Pass Filter (cutoff freq. =1000MHz)	Trilithic	23042	27-Oct-16	27-Oct-17
Horn Antenna	EMCO	3115	25-Apr-16	25-Apr-17
Active Loop Antenna	EMCO	6502	26-Jul-16	26-Jul-17

AC Mains Conducted Emission

Equipment	Manufacturer	Type	Cal. Date	Due Date
Test Receiver	R & S	ESU40	26-Jul-16	26-Jul-17
RF Voltage Probe	Schwarzbeck	TK9416	11-Feb-16	11-Feb-17
LISN	R&S	ESH3-Z5	15-Jun-16	15-Jun-17
Double Shield Cable	Radiall	RG142	14-Sep-15	14-Sep-17
Pulse Limiter	R&S	ESH3-Z2	3-Jun-16	3-Jun-18

TÜV Rheinland Hong Kong Ltd

Radio Test

Equipment	Manufacturer	Type	Cal. Date	Due Date
Spectrum Analyzer	R & S	FSV40	28-Dec-15	28-Dec-16

Measurement Uncertainty

The estimated combined standard uncertainty for power-line conducted emissions measurements is ± 2.42 dB.

The estimated combined standard uncertainty for radiated emissions measurements is ± 4.81 dB (9kHz to 30MHz) and ± 4.62 dB (30MHz to 200MHz) and ± 5.67 dB (200MHz to 1000MHz) and is ± 5.07 dB (1GHz to 8.2GHz) and ± 4.58 dB (8.2GHz to 12.4GHz) and ± 4.78 dB (12.4GHz to 18GHz).

The estimated combined standard uncertainty for antenna conducted emission is ± 1.56 dB

The reported expanded uncertainty of measurement is stated as the standard uncertainty of measurement multiplied by the coverage factor of $k=2$, which for the level of confidence is approximately 95%.

Results FCC Part 15 – Subpart C

FCC 15.203 – Antenna Requirement 1	Pass
FCC Requirement: No antenna other than that furnished by the responsible party shall be used with the device	
Results:	a) Antenna type: Integral Chip Antenna b) Manufacturer and model no: ONEWAVE WAN5010F245M0X c) Peak Gain: 3.09 dBi
Verdict:	Pass

FCC 15.204 – Antenna Requirement 2	N/A
FCC Requirement: An intentional radiator may be operated only with the antenna with which it is authorized. If an antenna is marketed with the intentional radiator, it shall be of a type which is authorized with the intentional radiator.	
Results:	Only one integral antenna can be used.
Verdict:	N/A

FCC 15.207 – Disturbance Voltage on AC Mains	N/A
There is no AC power input or output ports on the EUT	

FCC 15.247(b)(1) – Peak Output Power	Pass		
Test Specification : ANSI C63.10 – 2013 Mode of operation : Tx mode Port of testing : Temporary antenna port Supply voltage : 3.7 Vdc Temperature : 23°C Humidity : 50%			
FCC Requirement : For frequency hopping systems operating in the 2400-2483.5 MHz band employing at least 75 non-overlapping hopping channels, and all frequency hopping systems in the 5725-5850 MHz band: 1 Watt. For all other frequency hopping systems in the 2400-2483.5 MHz band: 0.125 Watts.			
Results: Pre-scan has been conducted to determine the worst-case mode from all possible combinations between available modulations and packet types. The worst cases is found in 8DPSK and 3Mbps. For test protocols please refer to Appendix 1.			
Frequency (MHz)	Maximum peak output power (dBm)	Limit (dBm)	Verdict
2402	4.64	21.0	Pass
2441	5.62	21.0	Pass
2480	6.41	21.0	Pass

FCC 15.247(a) – 20 dB Bandwidth			Pass
FCC Requirement: N/A			
Test Specification : ANSI C63.10 – 2013 Mode of operation : Tx mode Port of testing : Temporary antenna port Supply voltage : 3.7 Vdc Temperature : 23°C Humidity : 50%			
Results: Pre-scan has been conducted to determine the worst-case mode from all possible combinations between available modulations and packet types. The worst cases is found in 8DPSK and 3Mbps. For test protocols refer to Appendix 1.			
Frequency (MHz)	20 dB left (MHz)	20 dB right (MHz)	20dB bandwidth (MHz)
2402	2401.36	2402.629	1.269
2441	2440.36	2441.624	1.264
2480	2479.36	2480.624	1.264

FCC 15.247(a)(1) – Carrier Frequency Separation			Pass
FCC Requirement: Frequency hopping systems shall have hopping channel carrier frequencies separated by a minimum of 25kHz or the 2/3*20dB bandwidth of the hopping channel, whichever is greater.			
Test Specification : ANSI C63.10 – 2013 Mode of operation : Tx mode (hopping on) Port of testing : Temporary antenna port Supply voltage : 3.7 Vdc Temperature : 23°C Humidity : 50%			
Results: For test Results plots refer to Appendix 1.			
Channel Separation (kHz)	Limit (kHz)	Verdict	
998.00	846.00	Pass	

FCC 15.247 (a)(1)(iii) – Number of hopping channels		Pass
FCC Requirement: Frequency hopping systems operating in the 2400MHz-2483.5MHz bands shall use at least 15 hopping frequencies.		
Test Specification : ANSI C63.10 – 2013 Mode of operation : Tx mode (hopping on) Port of testing : Temporary antenna port Supply voltage : 3.7 Vdc Temperature : 23°C Humidity : 50%		
Results: For test Results plots refer to Appendix 1.		
No. of hopping channels	Limit	Verdict
79	15	Pass

FCC 15.247 (a)(1)(iii) – Time of Occupancy (Dwell Time)		Pass
FCC Requirement: Frequency hopping systems in the 2400-2483.5 MHz band shall use at least 15 channels. The average time of occupancy on any channel shall not be greater than 0.4 seconds within a period of 0.4 seconds multiplied by the number of hopping channels employed.		
Test Specification : ANSI C63.10 – 2013 Mode of operation : Tx mode (hopping on) Port of testing : Temporary antenna port Supply voltage : 3.7 Vdc Temperature : 23°C Humidity : 50%		
Results:		
Time period calculation = $0.4 \times 79 = 31.6s$ Dwell time = $108 \times 2.895 \times 10^{-3} = 0.313 s$ $\leq 0.4 s$		
For test protocols please refer to Appendix 1.		
Verdict: Pass		

FCC 15.247 (a) – Hopping Sequence	Pass
<p>FCC Requirement: The system radio frequency (RF) bandwidth is equal to the channel bandwidth multiplied by the number of channels in the hopset. The hopset shall be such that the near-term distribution of frequencies appears random, with sequential hops randomly distributed in both direction and magnitude of change in the hopset, while the long-term distribution appears evenly distributed.</p>	
<p>The EUT complies with the Bluetooth RF specifications which is proven to fulfill this requirement. Please refer to the Bluetooth standard for detail.</p>	

FCC 15.247 (a) – Equal Hopping Frequency Use	Pass
<p>FCC Requirement: Each of the transmitter's hopping channels is used equally on average.</p> <p>The system radio frequency (RF) bandwidth is equal to the channel bandwidth multiplied by the number of channels in the hopset. The hopset shall be such that the near-term distribution of frequencies appears random, with sequential hops randomly distributed in both direction and magnitude of change in the hopset, while the long-term distribution appears evenly distributed.</p>	
<p>The EUT complies with the Bluetooth RF specifications which is proven to fulfill this requirement. Please refer to the Bluetooth standard for detail.</p>	

FCC 15.247 (a) – Receiver Input Bandwidth	Pass
<p>FCC Requirement: The associated receiver(s) complies with the requirement that its input bandwidth matches the bandwidth of the transmitted signal.</p>	
<p>The EUT complies with the Bluetooth RF specifications which is proven to fulfill this requirement. Please refer to the Bluetooth standard for detail.</p>	

FCC 15.247 (a) – Receiver Hopping Capability	Pass
<p>FCC Requirement: The associated receiver has the ability to shift frequencies in synchronisation with the transmitted signals.</p>	
<p>The EUT complies with the Bluetooth RF specifications which is proven to fulfill this requirement. Please refer to the Bluetooth standard for detail.</p>	

FCC 15.247 (d) – Spurious Conducted Emissions					Pass
Test Specification : ANSI C63.10 – 2013 Mode of operation : Tx mode Port of testing : Temporary antenna port Supply voltage : 3.7 Vdc Temperature : 23 °C Humidity : 50 %					
FCC Requirement: In any 100 kHz bandwidth outside the frequency band in which the spread spectrum or digitally modulated intentional radiator is operating, the radio frequency power that is produced by the intentional radiator shall be at least 20 dB below that in the 100 kHz bandwidth within the band that contains the highest level of the desired power, based on either an RF conducted or a radiated measurement.					
Results: Pre-scan has been conducted to determine the worst-case mode from all possible combinations between available modulations and packet types. There is no peak found outside any 100kHz bandwidth of the operating frequency band in the three transmit frequency. All three transmit frequency modes comply with the limit stated in subclause 15.247(d). For test protocols refer to Appendix 1.					
Operating frequency (MHz)	Spurious frequency (MHz)	Spurious Level (dBm)	Reference value (dBm)	Delta (dB)	Verdict
2402	2555.40	-45.06	3.25	48.31	Pass
2441	6925.10	-46.14	4.20	50.34	Pass
2480	2633.40	-46.62	4.74	51.36	Pass

FCC 15.205 – Radiated Emissions in Restricted Frequency Bands					Pass
Test Specification : ANSI C63.10 – 2013 Mode of operation : TX mode Port of testing : Enclosure Detector : Peak Supply voltage : 3.7 Vdc Temperature : 23°C Humidity : 50%					
FCC Requirement: In any 100kHz bandwidth outside the frequency band at least 20dB below the highest level of the desired power. In addition, radiated emissions which fall in the restricted bands, as defined in section 15.205(a), must also comply with the radiated emission limits specified in section 15.205(c).					
Results: Pre-scan has been conducted to determine the worst-case mode from all possible combinations between available modulations and data rate. The worst cases is found in GFSK and 1Mbps. Simultaneous transmission was investigated and no new emissions were found. All three transmit frequency modes comply with the field strength within the restricted bands. There is no spurious found below 30MHz.					

Mode: 2402 MHz TX			Vertical Polarization		
Freq MHz	Level dBuV/m	Limit/ Detector dBuV/m			
46.050	23.6	40.0 / QP			
2389.679	45.87	74.0 / PK			
2389.679	33.61	54.0 / AV			
4804.000	59.34	74.0 / PK			
4804.000	49.09	54.0 / AV			
Mode: 2402 MHz TX			Horizontal Polarization		
Freq MHz	Level dBuV/m	Limit/ Detector dBuV/m			
2390.000	46.21	74.0 / PK			
2390.000	33.59	54.0 / AV			
4804.000	60.88	74.0 / PK			
4804.000	52.42	54.0 / AV			
Mode: 2441 MHz TX			Vertical Polarization		
Freq MHz	Level dBuV/m	Limit/ Detector dBuV/m			
4882.000	55.90	74.0 / PK			
4882.000	44.16	54.0 / AV			
Mode: 2441 MHz TX			Horizontal Polarization		
Freq MHz	Level dBuV/m	Limit/ Detector dBuV/m			
4882.000	58.15	74.0 / PK			
4882.000	48.65	54.0 / AV			
Mode: 2480 MHz TX			Vertical Polarization		
Freq MHz	Level dBuV/m	Limit/ Detector dBuV/m			
60.000	25.7	40.0 / QP			
2483.500	60.47	74.0 / PK			
2483.500	47.52	54.0 / AV			
4960.000	55.79	74.0 / PK			
4960.000	41.05	54.0 / AV			
Mode: 2480 MHz TX			Horizontal Polarization		
Freq MHz	Level dBuV/m	Limit/ Detector dBuV/m			
2483.500	63.96	74.0 / PK			
2483.500	50.84	54.0 / AV			
4960.000	60.15	74.0 / PK			
4960.000	51.19	54.0 / AV			