

BM5510

User manual

V 2.0



Table OF CONTENTS:

1. Introduction	3
2. Important Safety Information	3
3. Product Interface	4
4. Operations	5
5. Troubleshooting	8
6. FAQ	9
7. Technical Specifications	12

1. Introduction

Phenomenal battery life. Highly-portable. Feature-packed. When the job calls for a reliable and portable fingerprint scanner, the ARATEK BM5510 Handheld ID Check Terminal is the only choice. The device features an ultra-long battery life that keeps going, making the ARATEK BM5510 the perfect biometrics tool for law enforcement, National ID, remote financial services, and many other applications.

2. Important Safety Information

Please follow the following safety instructions:

※Do not use liquid or aerosol cleaners for cleaning.

※Do not disassemble or modify the device.

※Do not try to charge the battery with other chargers.

※Do not yank the power cord or place anything on the power cord.

※Do not expose the device into fire or heat it, or it may cause crack and injury.

※Do not use or store the device under too hot, too cold or dusty environment.

※Do not drop, knock or shake the device violently, or it may damage internal circuit board.

※Do not forget to turn off the device before SIM card insert and remove.

3. Product Interface

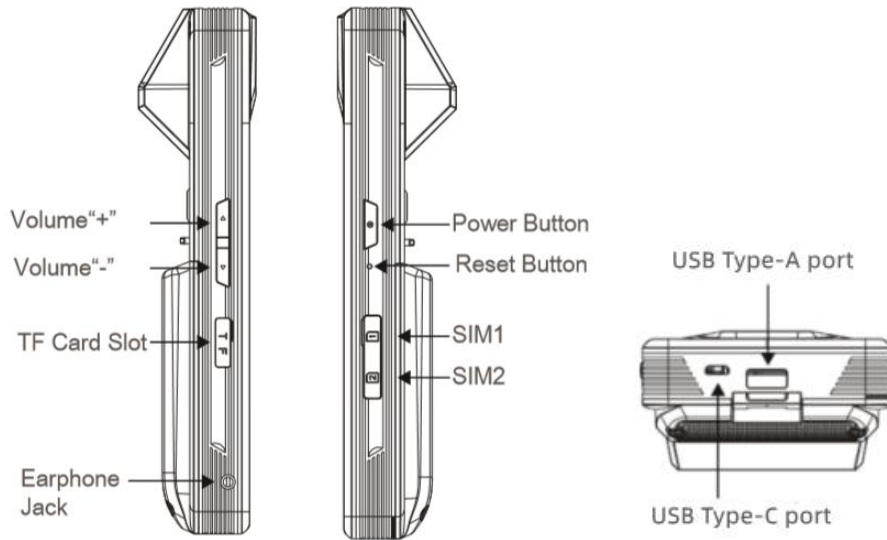
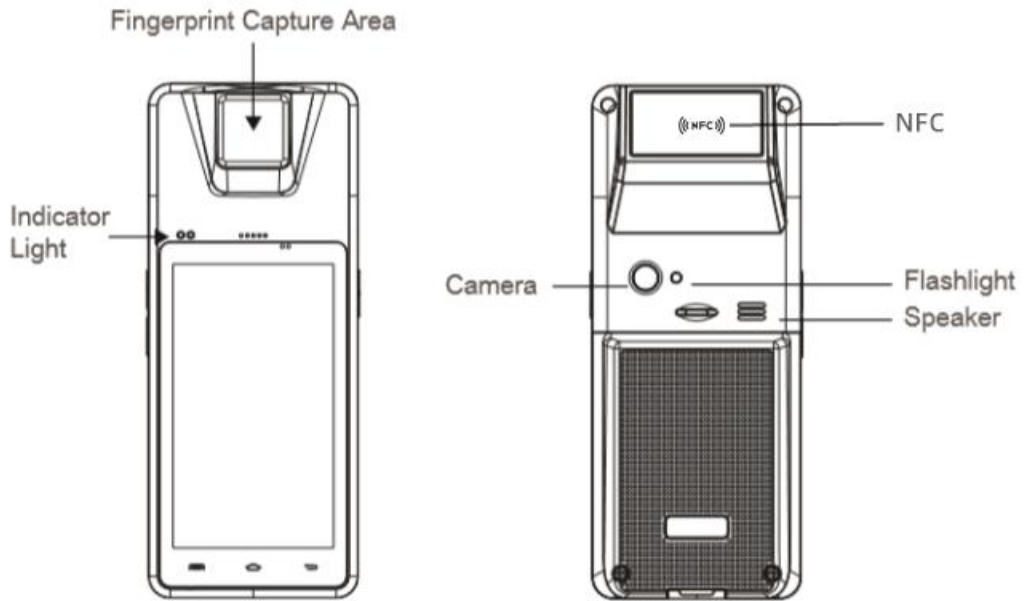

4. Operations



Before switching ON device for the first time or after a long time period, put it on charging until full power.

(1) How to charge

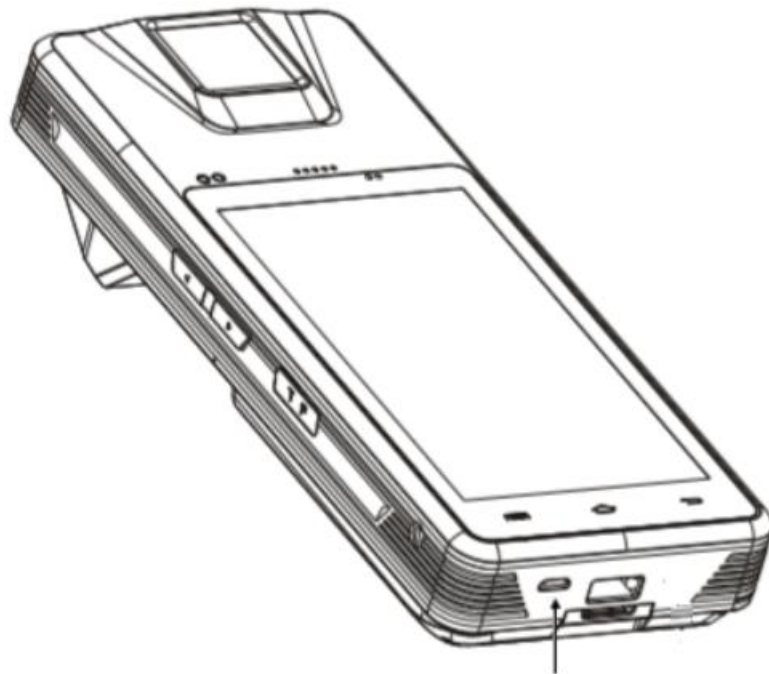

- Type C USB port can be used to charge the battery.
- When charge the device, plug in the USB cable in the device and the power adaptor.



- ✚ Even if the device is not switched ON, the battery will be charged whenever the DC Adaptor power is available.
- ✚ Red/green indicator light: red light when power charging is less than 95%; green light when power charging is greater than or equal to 95%

(2) Power On/Off operation

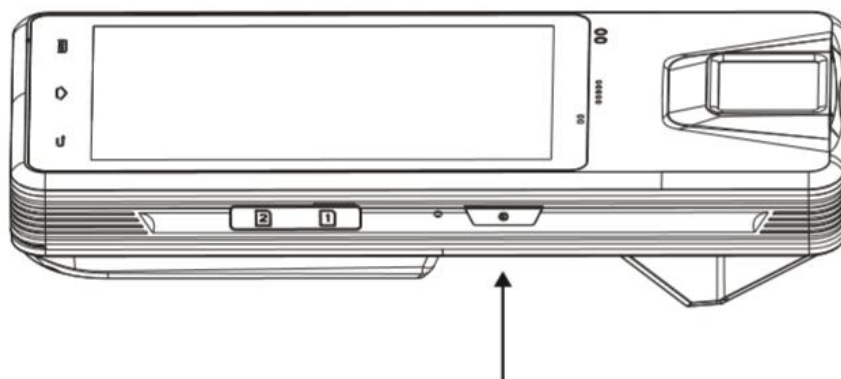

Long press power button two seconds to do On/Off operation

(3) Insert/Remove SIM card

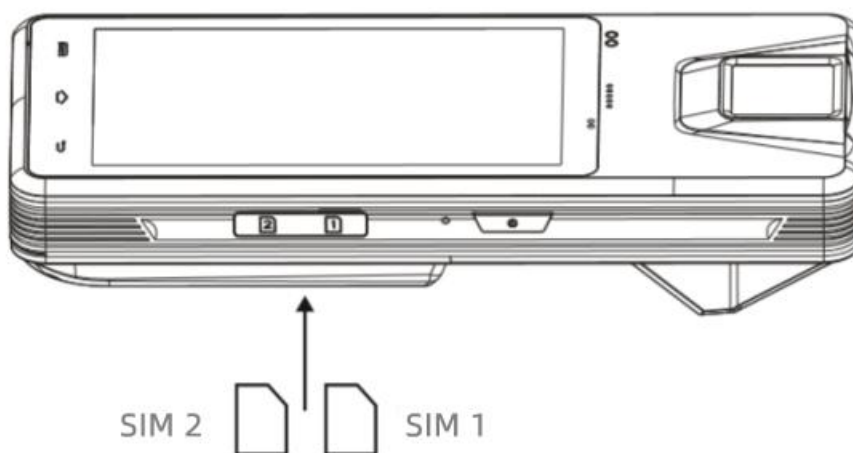

Pull out the SIM slot.
Insert the card into proper slot.
Then close the slot.

- There are two SIM slots, you can insert a maximum of two SIM cards.
- Ensure the device is turned OFF before inserting or removing a SIM card.

(4) Insert/Remove SD card

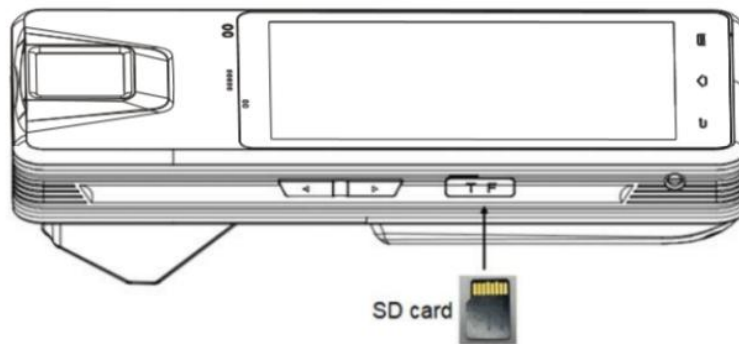

Pull out the TF slot
Insert the SD card (Back side up) in the slot
Then close the slot

(5) Remove battery

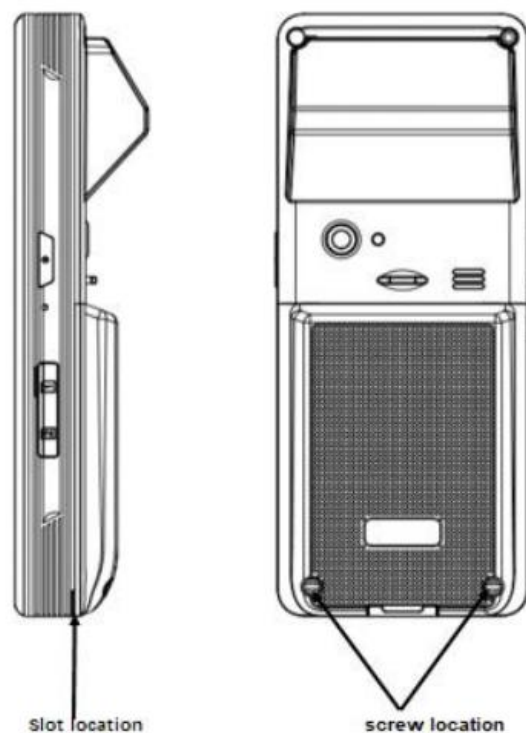

- Loosen two screws
- Open the battery cover through the slot
- Remove the battery

5. Troubleshooting

Problem 1: charging failure

Solution: (1) Check if the plug is inserted correctly.
(2) Ensure that micro USB charging port has good contact.

Problem 2: Over Heating

Solution: Avoid using the device under too hot environment. Stop device operation for a while.

Problem 3: System crash

Solution: a. Long press power button to turn off, then turn on.
b. Press reset button to restart device.
c. Contact Aratek support team.

Problem 4: Other problems

Solution: Contact Aratek for support, website: www.aratek.co

6. FAQ

1. How to enable USB device mode?

- Go to: **Settings---Connected Devices** menu, then manually enable **USB Device Mode** option.

2. Why I can't use fingerprint after I transfer files between device and PC?

- When you copy the files between the device and the PC, you need to enable the **USB device mode**.
- After file transfer, you have to disable the **USB device** mode unless your fingerprint can't work..
- Go to: **Settings---Connected Devices--- USB Device Mode** to disable the USB device mode

3. How to transfer files between BM5510 and PC, why BM5510 can't be found in my PC?.

- Please follow below steps:

- 1) Enable **USB device mode**.
- 2) Connect a PC by a Type C cable.
- 3) Click and open the notification message (**Android system-Charging this device via USB**).
- 4) Choose **file transfer** by this path: **Settings---Connected Devices--- USB Preferences**.
- 5) Open your PC, you can find BM5510 is in your PC and you can transfer file between BM5510 and your PC..
- 6) After file transfer, unplug the type C cable and disable the **USB device mode**

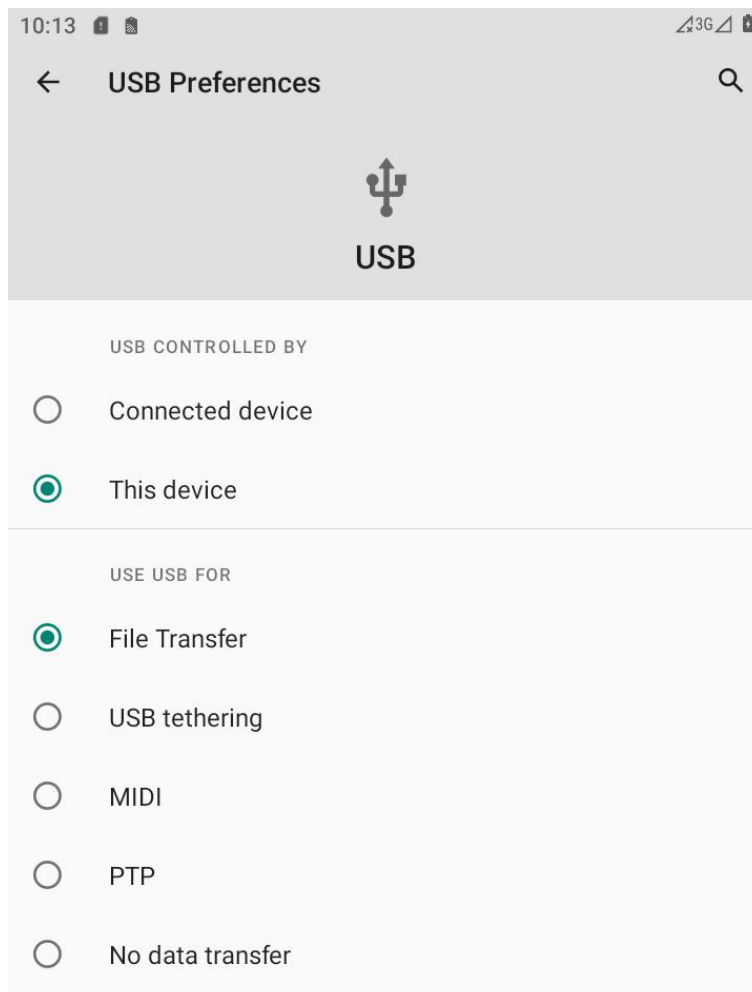
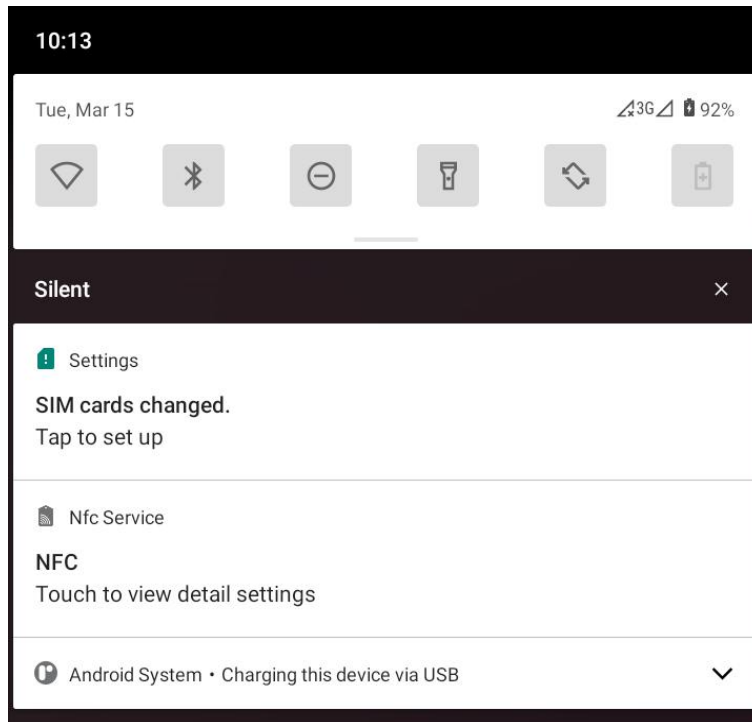

4. Is there a way we could do debugging from PC while keeping the fingerprint on?

- Please use **WI-FI-debugging**. Detailed steps were shown in Q5.

5. Why and how to do Wi-Fi Debug?

- Due to one USB port design in motherboard, fingerprint and TYPE C port cannot be used at the same time.
- Steps for Wi-Fi debug:

1) Turn on Android device USB Debugging and enable **USB device mode** , then connect device with PC.

2) Turn on Wi-Fi and connect the device to local area network, make sure your Android device and PC can communicate with each other in local area network.

3) Open command line and enter command like below:

adb tcpip 5555

adb shell netcfg

4) Find your Android device IP address, (such as 192.168.XXX.XXX),then disconnect the device, and enter command on PC:

adb connect 192.168.xxx.xxx

5) Disable the **USB device mode** (in **Settings---Connected Devices---USB Device Mode**).

6) Then, you can debug through Wi-Fi.

7. Technical Specifications

Basic	Operating System	Android 11
	Processor	Quad-core 2.0GHz
	Memory	2G RAM + 16G ROM
	Display	5 Inches 720*1280 Pixels IPS LCD
	Resolution	720*1280 IPS
	Camera	8 MP Auto Focus (Rear)
	Expansion Card	SD Card, Up to 256G
	Battery	10,000mAh removable
	Charging	Input: 100-240V, 50/60hz; Output: 9V/2A, Fast charging ability
	Weight	465g
	Dimension	201*82*46 mm (L*W*H)
	Accessories	Power adapter, Type-C cable
	Temperature and Humidity	Operation: -0°C~50°C, 10%-75% Storage: -20°C~60°C, 5%-85%
Biometrics	Type	FBI PIV certified FAP20 optical
	Platen Area	21.0*16.0 mm
	Sensing Area	20.3mm*15.2mm
	Image Size	Image Size: 300*400
	Image Resolution	500 dpi
	Grayscale	256 level
Communications	SIM Card	Micro Sim Card *2
	Wi-Fi	802.11 a/ac/b/g/n
	Bluetooth	Bluetooth 5.0
	2G	850&900&1800&1900
	3G	B1&B2&B5&B8
	4G	B1/B2/B3/B4/B5/B7/B8/B20/B28
	Location	GPS + GLONASS + Galileo + Beidou
	USB Ports	Type A USB 2.0 *1, Type-C *1
Credential Reading	NFC	ISO/IEC 14443 A/B,ISO 15693,ISO 18092

FCC Statement

1. This device complies with Part 15 of the FCC Rules. Operation is subject to the following two conditions:

(1) This device may not cause harmful interference.

(2) This device must accept any interference received, including interference that may cause undesired operation.

2. Changes or modifications not expressly approved by the party responsible for compliance could void the user's authority to operate the equipment.

NOTE:

This equipment has been tested and found to comply with the limits for a Class B digital device, pursuant to Part 15 of the FCC Rules. These limits are designed to provide reasonable protection against harmful interference in a residential installation.

This equipment generates uses and can radiate radio frequency energy and, if not installed and used in accordance with the instructions, may cause harmful interference to radio communications. However, there is no guarantee that interference will not occur in a particular installation. If this equipment does cause harmful interference to radio or television reception, which can be determined by turning the equipment off and on, the user is encouraged to try to correct the interference by one or more of the following measures:

Reorient or relocate the receiving antenna.

Increase the separation between the equipment and receiver.

Connect the equipment into an outlet on a circuit different from that to which the receiver is connected.

Consult the dealer or an experienced radio/TV technician for help.

SAR Information Statement

Your wireless phone is a radio transmitter and receiver. It is designed and manufactured not to exceed the emission limits for exposure to radiofrequency (RF) energy set by the Federal Communications Commission of the U.S. Government. These limits are part of comprehensive guidelines and establish permitted levels of RF energy for the general population. The guidelines are based on standards that were developed by independent scientific organizations through periodic and thorough evaluation of scientific studies. The standards include a substantial safety margin designed to assure the safety of all persons, regardless of age and health. The exposure standard for wireless mobile phones employs a unit of measurement known as the Specific Absorption Rate, or SAR. The SAR limit set by the FCC is 1.6 W/kg. * Tests for SAR are conducted with the phone transmitting at its highest certified power level in all tested frequency bands. Although the SAR is determined at the highest certified power level, the actual SAR level of the phone while operating can be well below the maximum value. This is because the phone is designed to operate at multiple power levels so as to use only the power required to reach the network. In general, the closer you are to a wireless base station antenna, the lower the power output. Before a phone model is available for sale to the public, it must be tested and certified to the FCC that it does not exceed the limit established by the government adopted requirement for safe exposure. The tests are performed in positions and locations (e.g., at the ear and worn on the body) as required by the FCC for each model. The highest SAR value for this model phone when tested for use at the ear is 1.169W/Kg and when worn on the body, as described in this user guide, is 0.8751W/Kg(Body-worn measurements differ among phone models, depending upon available accessories and FCC requirements). The maximum scaled SAR in hotspot mode is 0.875W/Kg. While there may be differences between the SAR levels of various phones and at various positions, they all meet the government requirement for safe exposure. The FCC has granted an Equipment Authorization for this model phone with all reported SAR levels evaluated as in compliance with the FCC RFexposure guidelines. SAR information on this model phone is on file with the FCC and can be found under the Display Grant section of <http://www.fcc.gov/oet/fccid> after searching on

FCC ID: 2AGUJBM5510S Additional information on Specific Absorption Rates (SAR) can be found on the Cellular Telecommunications Industry Association (CTIA) web-site at <http://www.wow-com.com>.

* In the United States and Canada, the SAR limit for mobile phones used by the public is 1.6 watts/kg (W/kg) averaged over one gram of tissue. The standard incorporates a substantial margin of safety to give additional protection for the public and to account for any variations in measurements.

Body-worn Operation

This device was tested for typical body-worn operations. To comply with RF exposure requirements, a minimum separation distance of 10mm must be maintained between the user's body and the handset, including the antenna. Third-party belt-clips, holsters, and similar accessories used by this device should not contain any metallic components. Body-worn accessories that do not meet these requirements may not comply with RF exposure requirements and should be avoided. Use only the supplied or an approved antenna.