

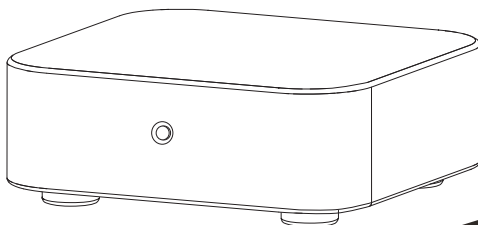

INSTALLATION MANUAL

ES-SUB-WIRELESS-KIT

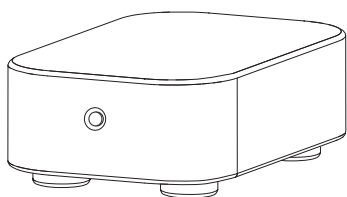

REAL. LIFE. SOUND.

INTRODUCTION

Thank you for purchasing Episode® Electronics. To complete installation, follow these guidelines. Visit our website for design recommendations and speaker calculators.

Subwoofer placement can have a large impact on the overall sound quality of low frequencies. This Episode® wireless subwoofer kit allows subwoofer placement anywhere in the room without running wires.

CONTENTS

- 1x Wireless transmitter
- 1x Wireless receiver
- 2x Power supply

SETUP

SYSTEM CONNECTIVITY

1. Use high-quality shielded RCA cables with low impedance, and high-quality connectors. Connect the wireless transmitter to the AV receiver utilizing a dedicated subwoofer connection (LFE) or L/R preamp output or to a TV using an RCA cable.
2. Use a dedicated subwoofer connection (LFE) or left/right preamp output. Connect the wireless to the LEFT or LFE input on the subwoofer. A splitter may also be used to send the signal to both the LEFT/RIGHT input for higher volume levels on some subwoofers.

Refer to the subwoofer owner's manual for specific information on connections and setup.

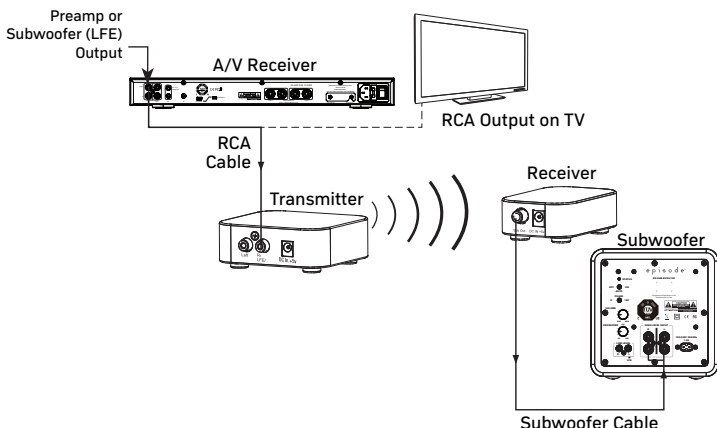



SUBWOOFER PLACEMENT

Subwoofer placement has an effect on overall audio performance.

The strongest audio output will likely occur if the subwoofer is placed in a corner of the room on the same wall as the front channel speakers. This is known as the boundary effect and will emphasize certain bass frequencies while canceling others. Some listeners will find this to be the best sounding result, while others may find it overly “boomy” or muddy.

Once the wireless kit is paired, experiment with subwoofer placement to find the location that delivers the best audio performance.

PAIRING YOUR EPISODE® WIRELESS KIT

Initial pairing may be performed without the audio signals connected. This may be preferred for easier access to the pairing buttons and power connections.

Follow the instructions below to pair wireless transmitter and receiver.

1. Plug in all transmitters and receivers.
The power cords can be routed through the strain relief detail to prevent the cord from being pulled out.
2. Press and hold the pair button on the receiver until the LED flashes. Repeat this procedure for all receivers if using more than one.

NOTE: Up to 4 receivers may be paired to 1 transmitter

3. Press and hold the pair button on the Transmitter.

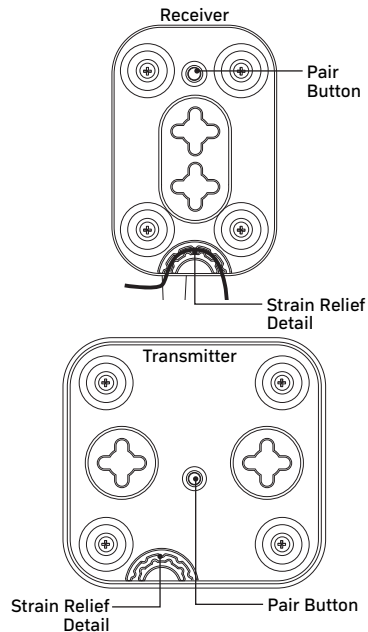

4. All LEDs should stop flashing and stay solid within 5 seconds.
5. Unplug all units and mount in final locations. Pairing is persistent and will not be lost when unplugged.

NOTE: Wireless devices may be susceptible to RF interference from other devices. To reduce potential interference and maximize wireless performance, check the proximity to other wireless devices and relocate them accordingly if interference is present. Signal interference created by microwave ovens, ceiling fans, or other appliances will subside when those devices are not in use.

SPECIFICATIONS

Modulation	QPSK
Operating Frequency	5.18GHz ~ 5.24GHz, 5.736GHz~5.814GHz
Channel Width	<22 MHz
Latency	<20 ms
Typical Range	30 ft. max. (10m)
Transmitter Power	0 dB
S/N	84 dB
Max Input Signal (LFE)	1.84 V

WARRANTY

Lifetime Limited Warranty

Episode® Accessories have a Lifetime Limited Warranty. This warranty includes parts and labor repairs on all components found to be defective in material or workmanship under normal conditions of use. This warranty shall not apply to products that have been abused, modified or disassembled. Products to be repaired under this warranty must be returned to a designated service center with an assigned return authorization (RA) number. Contact technical support at support@episodeaudio.com for an RA number.

CONTACTING TECHNICAL SUPPORT

866.838.5052

support@episodeaudio.com



FCC Information and Copyright

Operations in the 5.18~5.24GHz band are restricted to indoor usage only.

This equipment has been tested and found to comply with the limits for a Class B digital device, pursuant to part 15 of the FCC Rules.

These limits are designed to provide reasonable protection against harmful interference in a residential installation. This equipment generates,

uses and can radiate radio frequency energy and, if not installed and used in accordance with the instructions, may cause harmful interference

to radio communications. However, there is no guarantee that interference will not occur in a particular installation. If this equipment does

cause harmful interference to radio or television reception, which can be determined by turning the equipment off and on, the user is

encouraged to try to correct the interference by one or more of the following measures:

- Reorient or relocate the receiving antenna.
- Increase the separation between the equipment and receiver.
- Connect the equipment into an outlet on a circuit different from that to which the receiver is connected.
- Consult the dealer or an experienced radio/TV technician for help.

This device complies with part 15 of the FCC Rules. Operation is subject to the following two conditions:

- (1) This device may not cause harmful interference, and
- (2) this device must accept any interference received, including interference that may cause undesired operation.

changes or modifications not expressly approved by the party responsible for compliance could void the user's authority to operate the equipment.

This equipment complies with FCC radiation exposure limits set forth for an uncontrolled environment. This equipment should be installed and operated with minimum distance 20cm between the radiator & your body. This transmitter must not be co-located or operating in conjunction with any other antenna or transmitter.