



# FCC / IC Test Report

FOR:

Moog Inc.

Model Name:

ILC3000

Product Description:

asset tracker

**FCC ID: 2AGRZ-ILC3000**

**IC ID: 20942-ILC3000**

**Per:**

47 CFR Part 15.247 (DTS)  
RSS-247 Issue 1 (DTS) & RSS-Gen Issue 4

**REPORT #:** EMC\_MOOGI-005-15001\_15.247\_WLAN

**DATE:** January 21, 2015



**CETECOM Inc.**

411 Dixon Landing Road • Milpitas, CA 95035 • U.S.A.

Phone: + 1 (408) 586 6200 • Fax: + 1 (408) 586 6299 • E-mail: [info@cetecom.com](mailto:info@cetecom.com) • <http://www.cetecom.com>  
CETECOM Inc. is a Delaware Corporation with Corporation number: 2905571

Test Report #:	EMC_MOOGI-005-15001_15.247_WLAN	FCC ID: 2AGRZ-ILC3000	
Date of Report	January 27, 2015	Page 2 of 67	

**TABLE OF CONTENTS**

<b>1</b>	<b>ASSESSMENT .....</b>	<b>4</b>
<b>2</b>	<b>ADMINISTRATIVE DATA.....</b>	<b>5</b>
2.1	IDENTIFICATION OF THE TESTING LABORATORY ISSUING THE EMC TEST REPORT.....	5
2.2	IDENTIFICATION OF THE CLIENT .....	5
2.3	IDENTIFICATION OF THE MANUFACTURER.....	5
<b>3</b>	<b>EQUIPMENT UNDER TEST (EUT).....</b>	<b>6</b>
3.1	EUT SPECIFICATIONS .....	6
3.2	EUT SAMPLE DETAILS.....	7
3.3	ACCESSORY EQUIPMENT (AE) DETAILS.....	7
3.4	TEST SAMPLE CONFIGURATION .....	7
3.5	SOFTWARE TOOL USED TO CONTROL EUT.....	8
3.6	WORST CASE CONDITION FOR EMISSION MEASUREMENT .....	9
3.7	DUTY CYCLE & DUTY CYCLE CORRECTION FACTOR .....	14
<b>4</b>	<b>SUBJECT OF INVESTIGATION.....</b>	<b>19</b>
<b>5</b>	<b>MEASUREMENT RESULTS SUMMARY .....</b>	<b>19</b>
<b>6</b>	<b>MEASUREMENT UNCERTAINTY .....</b>	<b>20</b>
<b>7</b>	<b>ENVIRONMENTAL CONDITIONS DURING TESTING:.....</b>	<b>20</b>
<b>8</b>	<b>DATES OF TESTING: .....</b>	<b>20</b>
<b>9</b>	<b>MEASUREMENT PROCEDURES.....</b>	<b>21</b>
9.1	RADIATED MEASUREMENT .....	21
9.2	SAMPLE CALCULATIONS FOR FIELD STRENGTH MEASUREMENTS .....	23
9.3	POWER LINE CONDUCTED MEASUREMENT PROCEDURE.....	23
9.4	RF CONDUCTED MEASUREMENT PROCEDURE.....	24
<b>10</b>	<b>MAXIMUM CONDUCTED AVERAGE OUTPUT POWER .....</b>	<b>25</b>
10.1	MEASUREMENT ACCORDING TO FCC KDB 558074 D01 V03R03, METHOD AVGSA-2 SECTION 9.2.2.4 .....	25
10.2	LIMITS: .....	25
10.3	TEST CONDITIONS AND SETUP:.....	25
10.4	MEASUREMENT RESULT: .....	26
10.5	MEASUREMENT PLOTS: .....	27
<b>11</b>	<b>POWER SPECTRAL DENSITY .....</b>	<b>30</b>
11.1	MEASUREMENT ACCORDING TO FCC KDB 558074 D01 V03R03 .....	30
11.2	LIMITS: §15.247 & RSS-247 .....	30
11.3	TEST CONDITIONS AND SETUP:.....	30
11.4	MEASUREMENT RESULT: .....	30
11.5	MEASUREMENT PLOTS: .....	31
<b>12</b>	<b>BAND EDGE COMPLIANCE .....</b>	<b>34</b>
12.1	MEASUREMENT ACCORDING TO FCC KDB 558074 D01 V03R03 .....	34
12.2	LIMITS RESTRICTED BAND §15.205 AND RSS-GEN 8.10.....	34
12.3	LIMITS NON RESTRICTED BAND §15.247 AND RSS-247 5.5 .....	35
12.4	TEST CONDITIONS AND SETUP:.....	35
12.5	MEASUREMENT RESULT: .....	36
12.6	MEASUREMENT PLOTS: .....	37
<b>13</b>	<b>EMISSION BANDWIDTH 6DB AND 99% OCCUPIED BANDWIDTH.....</b>	<b>43</b>

Test Report #:	EMC_MOOGI-005-15001_15.247_WLAN	FCC ID: 2AGRZ-ILC3000	
Date of Report	January 27, 2015	Page 3 of 67	

13.1	MEASUREMENT ACCORDING TO FCC KDB 558074 D01 v03R03 .....	43
13.2	LIMITS: §15.247 .....	43
13.3	TEST CONDITIONS AND SETUP:.....	43
13.4	MEASUREMENT RESULT: .....	43
13.5	MEASUREMENT PLOTS: .....	44
<b>14</b>	<b>RADIATED TRANSMITTER SPURIOUS EMISSIONS AND RESTRICTED BANDS .....</b>	<b>48</b>
14.1	MEASUREMENT ACCORDING TO ANSI C63.10 (2013) .....	48
14.2	LIMITS: §15.247/15.205/15.209 & RSS-GEN 8.9/ 8.10 (RESTRICTED BANDS) .....	48
14.3	TEST CONDITIONS AND SETUP:.....	49
14.4	MEASUREMENT RESULT: .....	49
14.5	MEASUREMENT PLOTS: .....	50
<b>15</b>	<b>AC POWER LINE CONDUCTED EMISSIONS.....</b>	<b>61</b>
15.1	LIMITS: .....	61
15.2	TEST CONDITIONS AND SETUP:.....	61
15.3	TEST PROCEDURE: .....	61
15.4	RESULTS: .....	62
15.5	TEST DATA: .....	62
15.6	MEASUREMENT PLOTS: .....	63
<b>16</b>	<b>SETUP PICTURES .....</b>	<b>64</b>
<b>17</b>	<b>EUT PICTURES .....</b>	<b>65</b>
<b>18</b>	<b>TEST EQUIPMENT AND ANCILLARIES USED FOR TESTING .....</b>	<b>66</b>
<b>19</b>	<b>REVISION HISTORY .....</b>	<b>67</b>

Test Report #:	EMC_MOOGI-005-15001_15.247_WLAN	FCC ID: 2AGRZ-ILC3000	
Date of Report	January 27, 2015	Page 4 of 67	

## 1 Assessment

The following device was evaluated against the applicable criteria specified in FCC rules Parts 15.247 of Title 47 of the Code of Federal Regulations and the relevant IC standard RSS-247.

No deviations were ascertained during the course of testing performed.

Company	Description	Model #
Moog Inc.	asset tracker	ILC3000

### Responsible for Testing Laboratory:

January 21, 2015    Compliance    Franz Engert  
 (Compliance Manager)

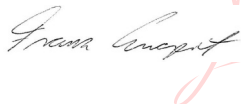
 Digitally signed by Franz Engert  
 DN: cn=Franz Engert, c=US, o=CETECOM, ou=Compliance, email=franz.engert@cetecom.com

Date	Section	Name	Signature
------	---------	------	-----------

### Responsible for the Report:

January 21, 2015    Compliance    Yu-Chien Ho  
 (EMC Engineer)

**Yu-Chien Ho**

Date	Section	Name	Signature
------	---------	------	-----------

The test results of this test report relate exclusively to the test item specified in Section 3. CETECOM Inc. USA does not assume responsibility for any conclusions and generalizations drawn from the test results with regard to other specimens or samples of the type of the equipment represented by the test item. The test report may only be reproduced or published in full. Reproduction or publication of extracts from the report requires the prior written approval of CETECOM Inc. USA.

Test Report #:	EMC_MOOGI-005-15001_15.247_WLAN	FCC ID: 2AGRZ-ILC3000	
Date of Report	January 27, 2015	Page 5 of 67	

## 2 Administrative Data

### 2.1 Identification of the Testing Laboratory Issuing the EMC Test Report

<b>Company Name:</b>	CETECOM Inc.
<b>Department:</b>	Compliance
<b>Address:</b>	411 Dixon Landing Road Milpitas, CA 95035 U.S.A.
<b>Telephone:</b>	+1 (408) 586 6200
<b>Fax:</b>	+1 (408) 586 6299
<b>Manager Compliance Services:</b>	Franz Engert
<b>Project Engineer:</b>	Yu-Chien Ho

### 2.2 Identification of the Client

<b>Clients Name:</b>	Moog Inc.
<b>Clients Address:</b>	1421 McCarthy Blvd.
<b>City/Zip Code</b>	Milpitas, CA 95035
<b>Country</b>	USA

### 2.3 Identification of the Manufacturer

<b>Manufacturer's Name:</b>	Same as Applicant
<b>Manufacturers Address:</b>	-----
<b>City/Zip Code</b>	-----
<b>Country</b>	-----

Test Report #:	EMC_MOOGI-005-15001_15.247_WLAN	FCC ID: 2AGRZ-ILC3000	
Date of Report	January 27, 2015	Page 6 of 67	

### 3 Equipment Under Test (EUT)

#### 3.1 EUT Specifications

<b>Model #:</b>	ILC3000
<b>HW Version :</b>	001
<b>SW Version :</b>	3.0.0.1
<b>FCC-ID :</b>	2AGRZ-ILC3000
<b>IC-ID:</b>	20942-ILC3000
<b>HVIN:</b>	ILC3000
<b>PMN:</b>	ILC 3000
<b>FVIN:</b>	NA
<b>Product Description:</b>	asset tracker
<b>Regulatory Band:</b>	Lower band edge 2400 MHz – upper band edge 2483.5 MHz
<b>Channels Used:</b>	2412(Ch. 1) – 2462(Ch. 1), 11 channels
<b>Type(s) of Modulation:</b>	802.11b/g/n with CCK, DQPSK, DBPSK + DSSS QBSK, BPSK, 16 QAM, 64 QAM + OFDM
<b>Modes of Operation:</b>	Access Point Infrastructure Mode, Group Owner, Station
<b>Antenna Type:</b>	2.4GHz High Efficiency Loop Antenna
<b>Max. Declared Antenna Gain:</b>	2.5 dBi
<b>Max. Measured Conducted Output</b>	18.22 dBm EIRP
<b>Power Supply:</b>	Li-ion Rechargeable Battery and AC/DC Battery Charger
<b>Rated Operating Voltage Range:</b>	<ul style="list-style-type: none"> <li>• Li-ion Rechargeable Battery: Vmin: 3.3V dDC/ Vnom: 3.7V DC / Vmax: 4.2V DC</li> <li>• AC/DC Battery Charger: 110V – 230V AC, 120mA.</li> </ul>
<b>Operating Temperature Range:</b>	T min: -20° C/ T max: 60° C
<b>Other Radios included in the Device:</b>	Cellular BTLE 4.1 GPS
<b>Sample Revision:</b>	<input checked="" type="checkbox"/> Prototype; <input type="checkbox"/> Production; <input type="checkbox"/> Pre-Production

Test Report #:	EMC_MOOGI-005-15001_15.247_WLAN	FCC ID: 2AGRZ-ILC3000	
Date of Report	January 27, 2015	Page 7 of 67	

### 3.2 EUT Sample details

EUT #	Serial Number	HW Version	SW Version	Notes/Comments
1	320002	001	3.0.0.1	Radiated Sample
2	320010	001	3.0.0.1	Conducted Sample

### 3.3 Accessory Equipment (AE) details

AE #	Type	Model	Manufacturer	Serial Number
1	AC/DC Power Supply	DCH3-05OUS-0002	Emerson	002187

### 3.4 Test Sample Configuration

EUT Set-Up #	Combination of AE used for test set up	Comments
1	EUT#1	The radio of the EUT was stimulated directly in a test mode not accessible by the end user. The internal antenna was connected.
2	EUT#2	The radio of the EUT was stimulated directly in a test mode not accessible by the end user. The measurement equipment was connected to the 50Ohm UFL port of the EUT.
3	EUT#1 + AE #1	The radio of the EUT was stimulated directly in a test mode not accessible by the end user. The internal antenna was connected.

### 3.5 Software tool used to control EUT

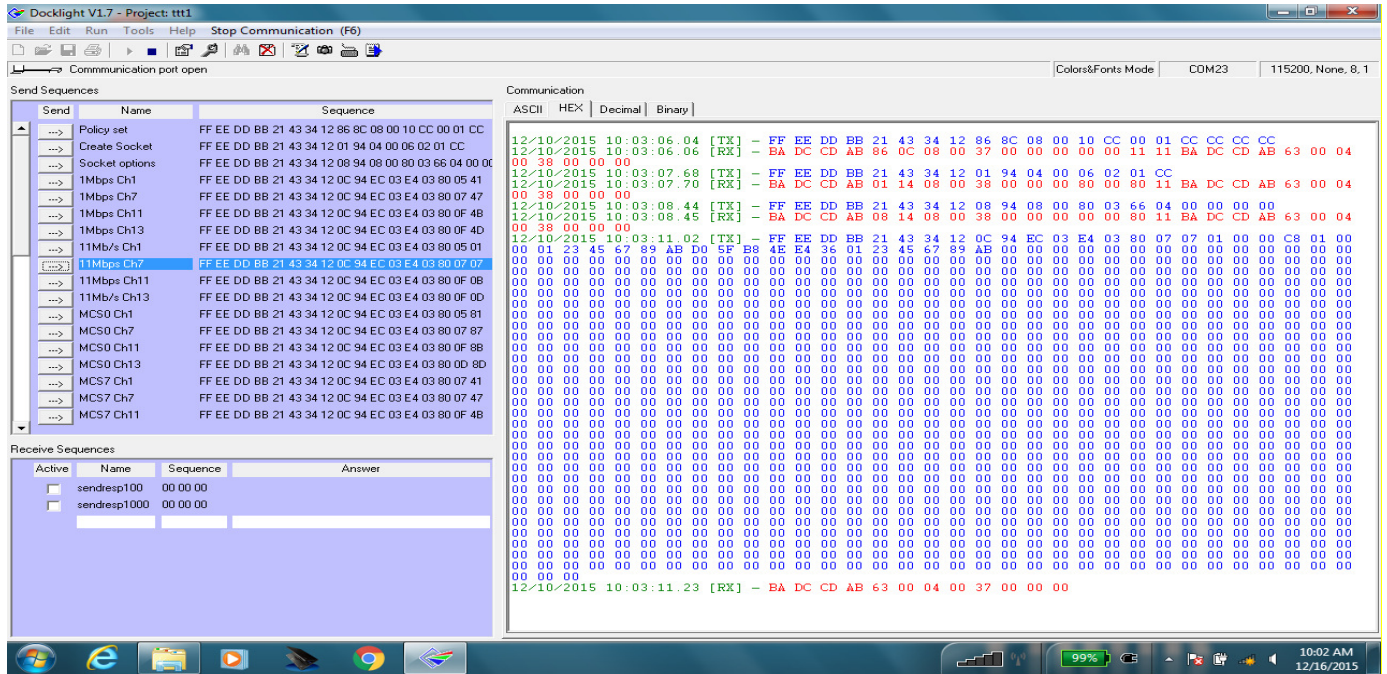



### 3.6 Worst case condition for emission measurement

All results are based on the EUT operating at its maximum declared peak envelope power.

To achieve this condition the EUT was set to the following Power Setting / Key value: 15.72 dBm/0.

An analysis over the supported modulations and bandwidths has been carried out on mid channel showing that 802.11b (11Mbps\_CCC)/20 MHz has the highest peak envelope power. All emission measurements in this report have been carried out in 802.11 b mode except the band edges restricted which have been tested in 802.11b and 802.11n to also verify conformance of the biggest OBW.

Modulation	Nominal Bandwidth	Average Power (dBm)	Corrected by Duty Cycle Correction Factor (dBm)	Corrected by Antenna Gain (dBi)	EIRP (dBm)
802.11 (1Mbps_DSSS)	20 MHz	15 dBm	0.25	2.5	17.75 dBm
802.11b (11Mbps_CCK)	20 MHz	14.62 dBm	1.1	2.5	18.22 dBm
802.11n (MCS0)	20 MHz	13.44 dBm	0.6	2.5	16.54 dBm
802.11n (MCS7)	20 MHz	3.51 dBm	8.1	2.5	14.11 dBm

$$\text{Duty Cycle} = 100 (\text{TX ON}) / (\text{TX ON} + \text{TX OFF})$$

$$\text{Duty Cycle Correction Factor} = 10 \log (\text{TX ON} + \text{TX OFF}) / \text{TX ON}$$

Modulation	TX ON + TX OFF (ms)	TX ON (ms)	Duty Cycle	Duty Cycle Correction Factor
802.11 (1Mbps_DSSS)	8.645	8.174	94.6%	0.25dB
802.11b (11Mbps_CCK)	1.171	0.913	78%	1.1dB
802.11n (MCS0)	1.459	1.269	87%	0.6dB
802.11n (MCS7)	0.954	0.147	15.4%	8.1dB

### 3.6.1 Plots

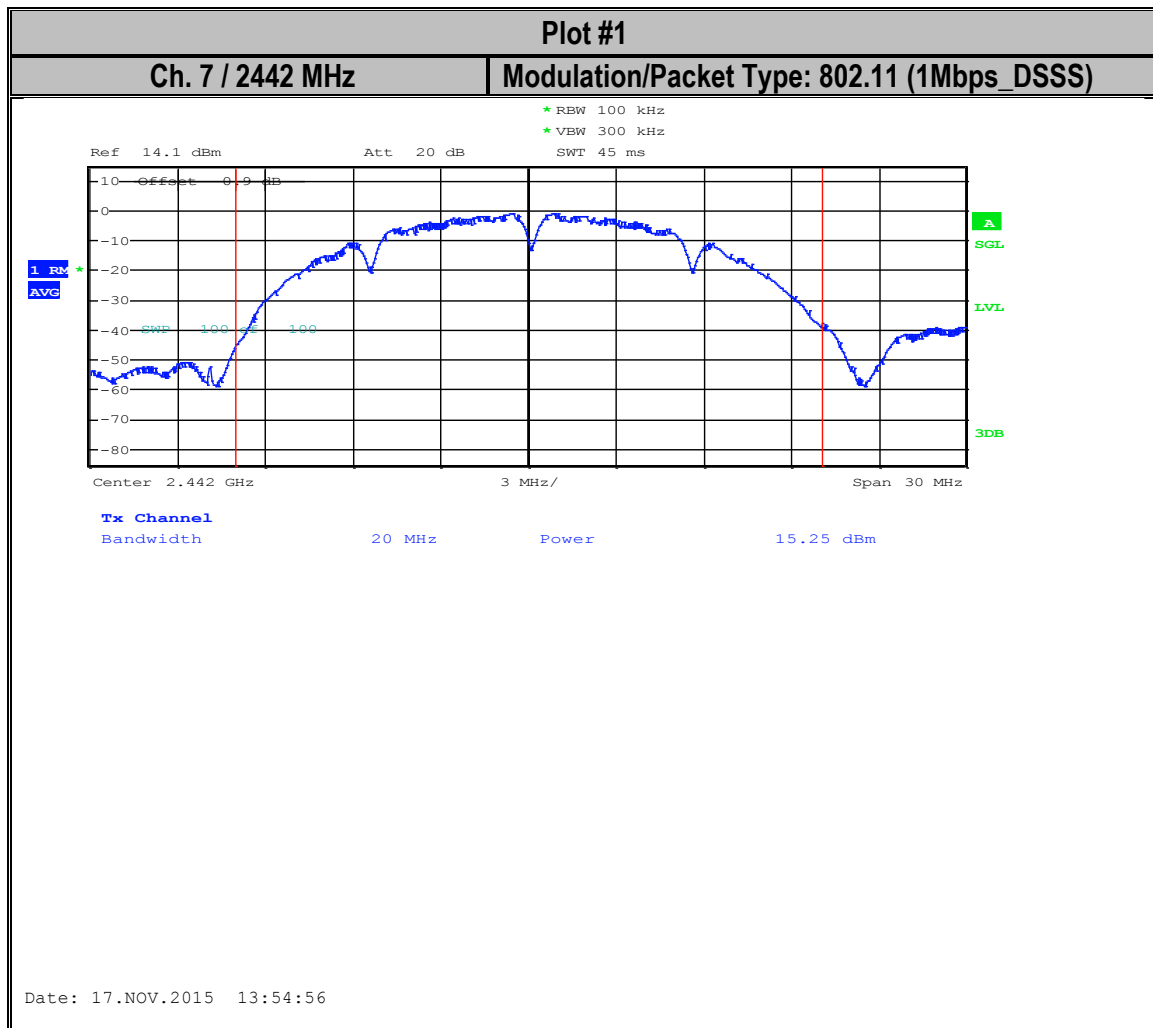

Note: Average output power already compensated for duty cycle correction factor.

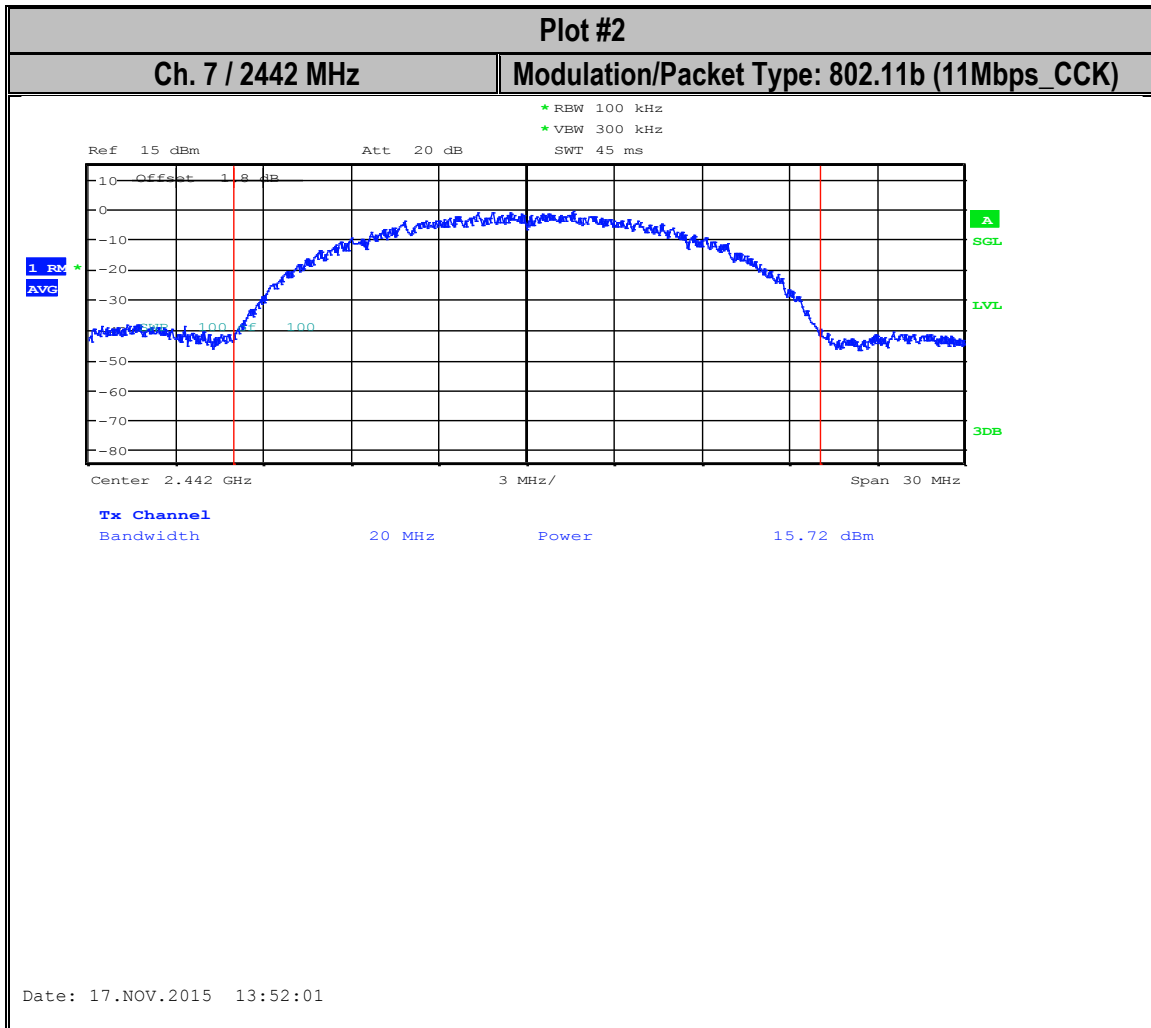

Note: Average output power already compensated for duty cycle correction factor.

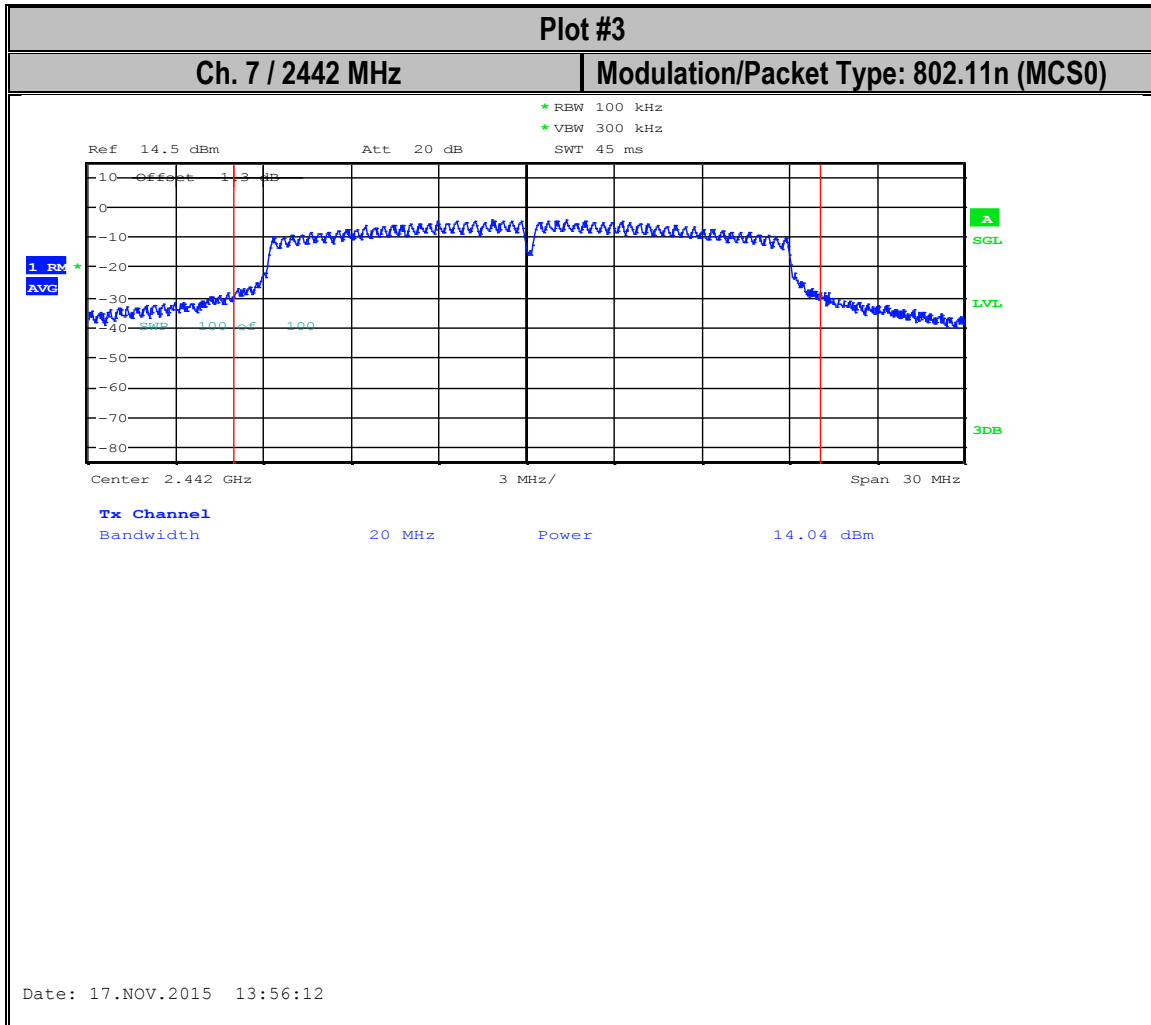

Note: Average output power already compensated for duty cycle correction factor.

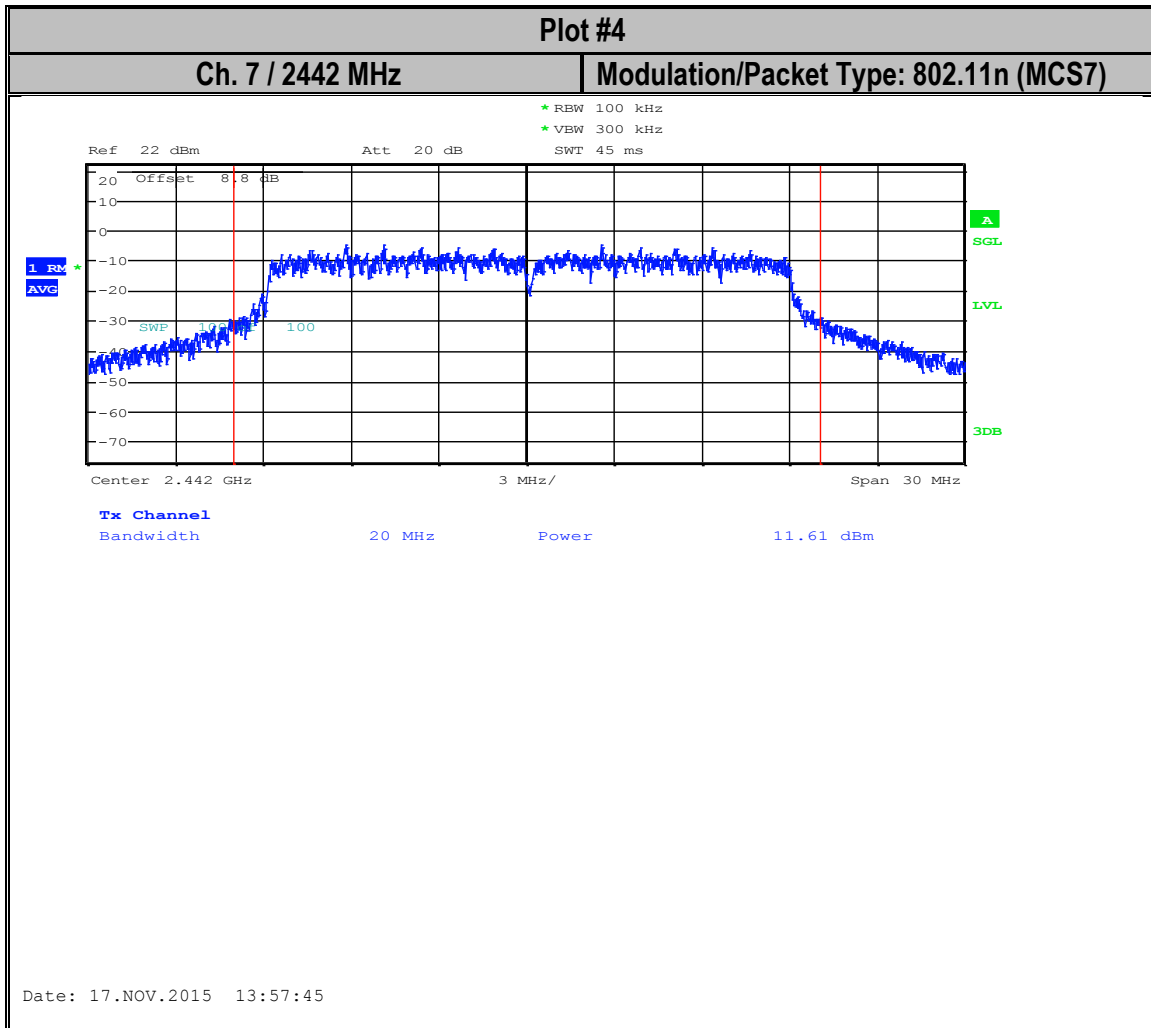

Note: Average output power already compensated for duty cycle correction factor.

### 3.7 Duty Cycle & Duty Cycle Correction Factor

Mode	Duty Cycle	Correction Factor
802.11b 1Mbps_DSSS	8.2ms / 8.6ms = 95%	0.2 dB
802.11b 11Mbps_DSSS	914us / 1171us = 78%	1.1 dB
802.11n MCS0	1.27ms / 1.46ms = 87%	0.6 dB
802.11n MCS0	147.7us / 954.6us = 15.5%	8.1 dB

#### 3.7.1 802.11b (1Mbps\_DSSS)

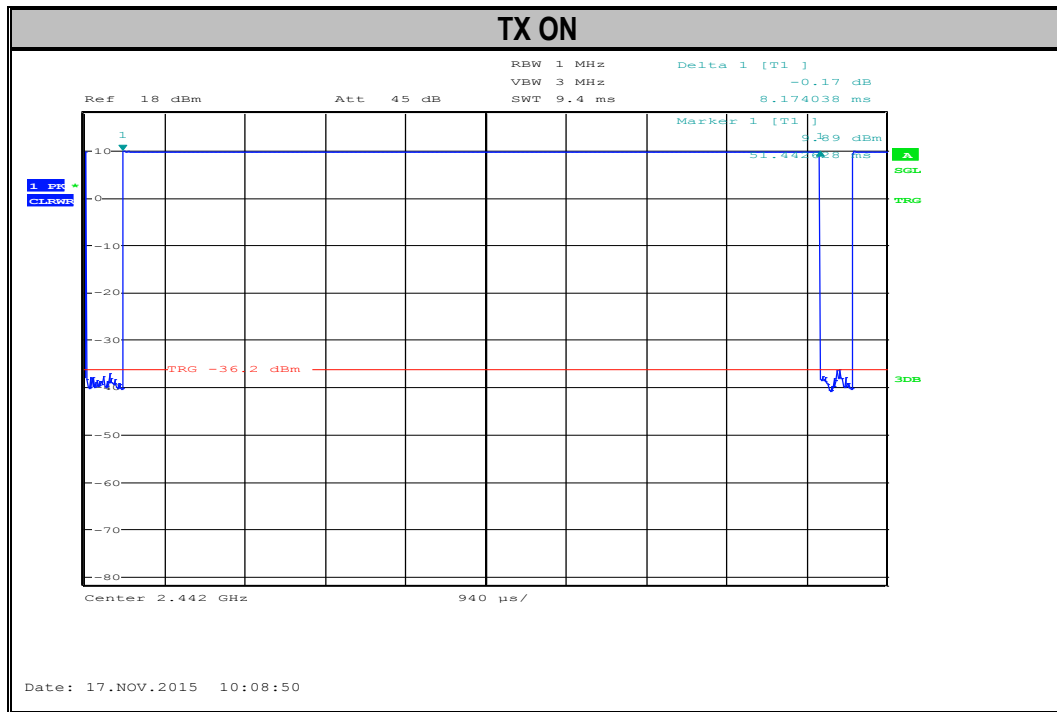

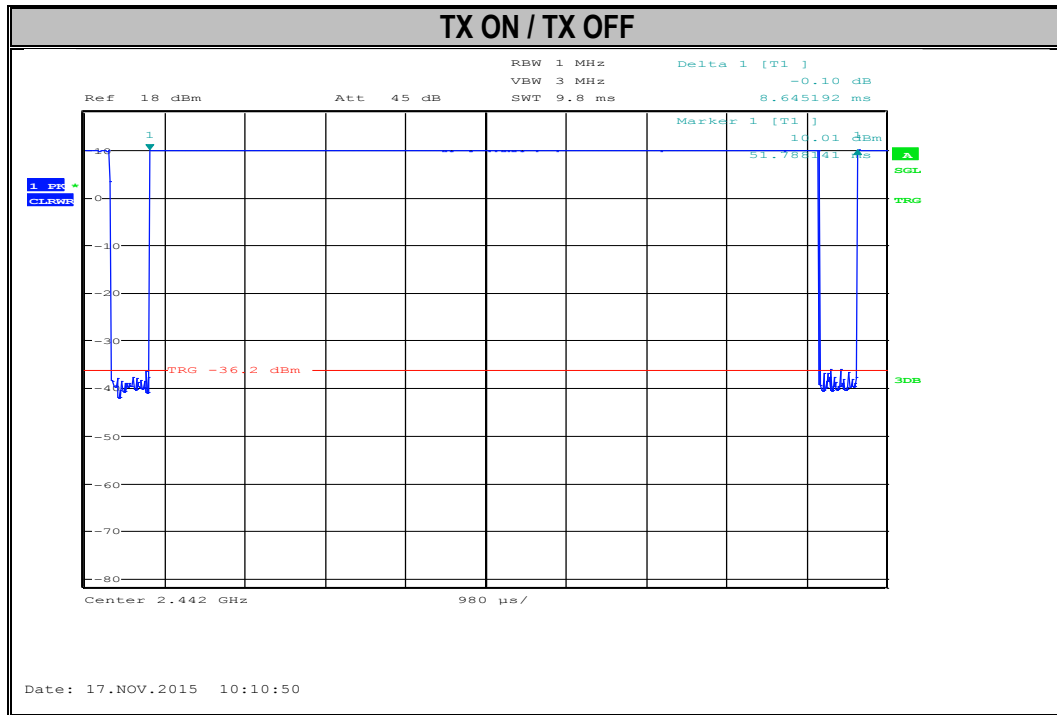

### 3.7.2 802.11b (11Mbps\_CCK)

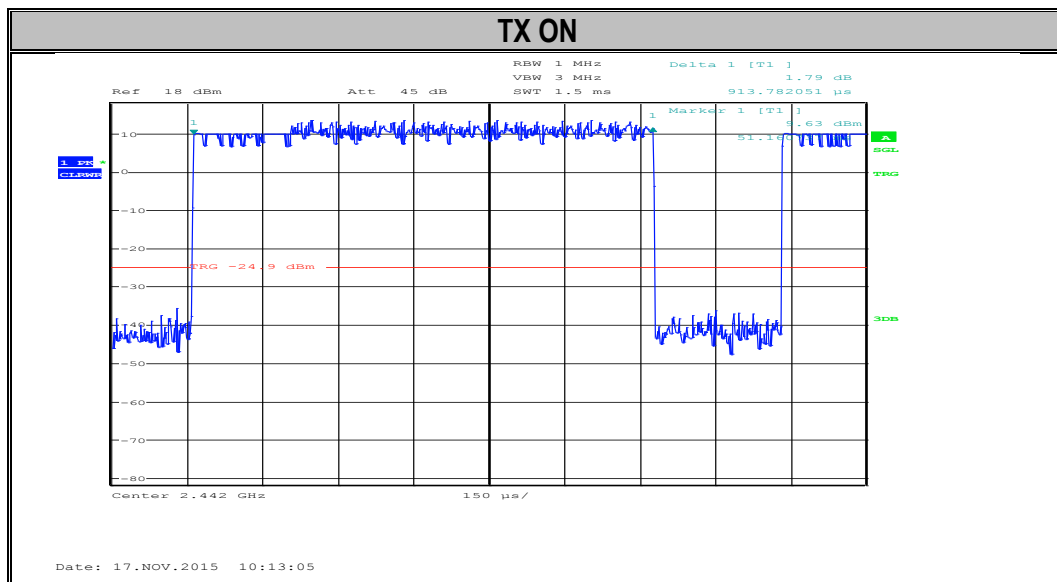

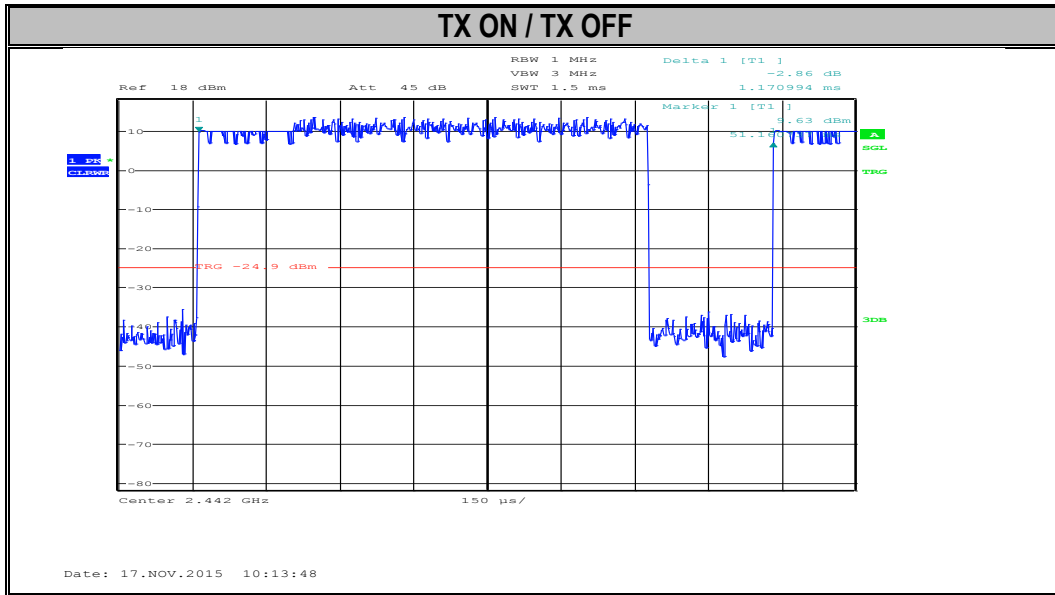



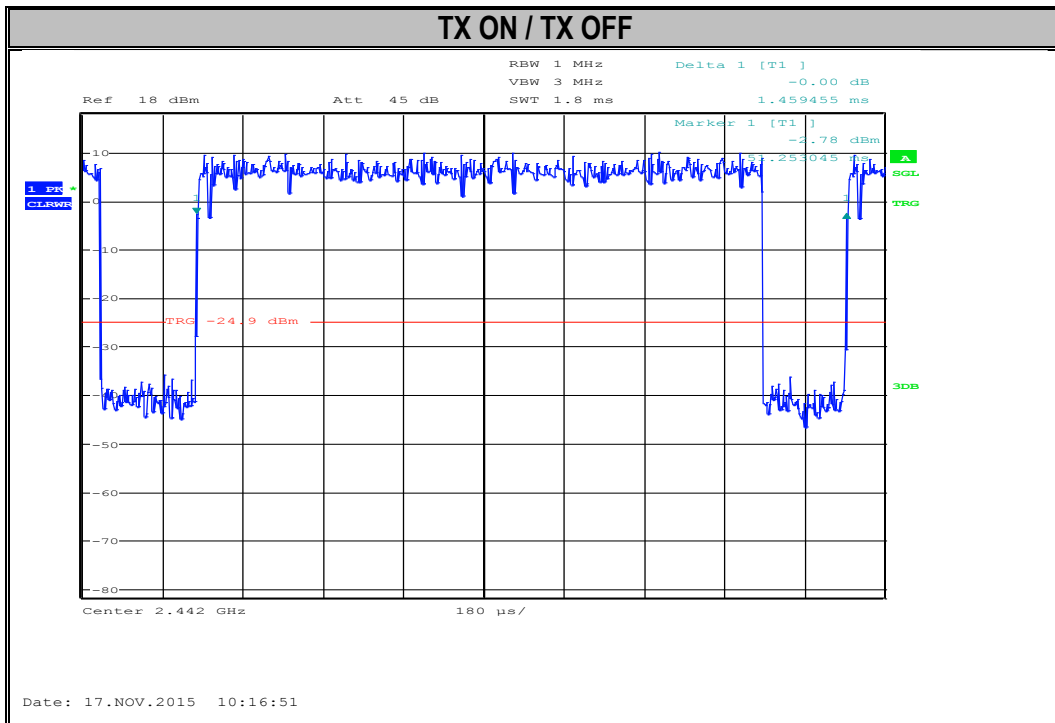
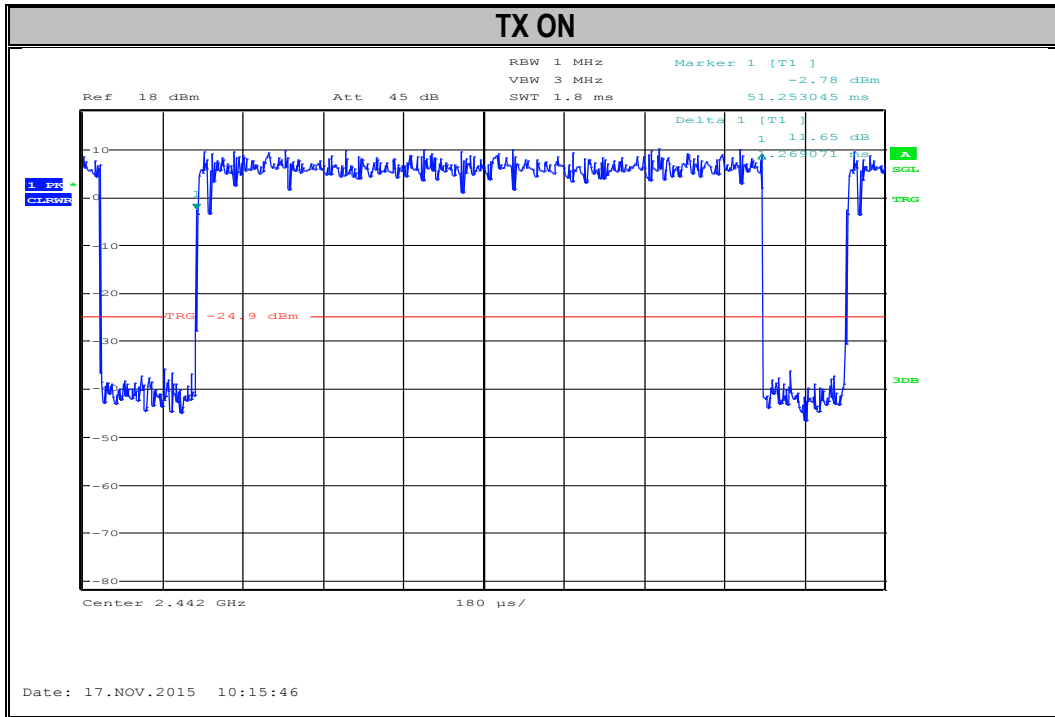

### 3.7.3 802.11n (MCS0)

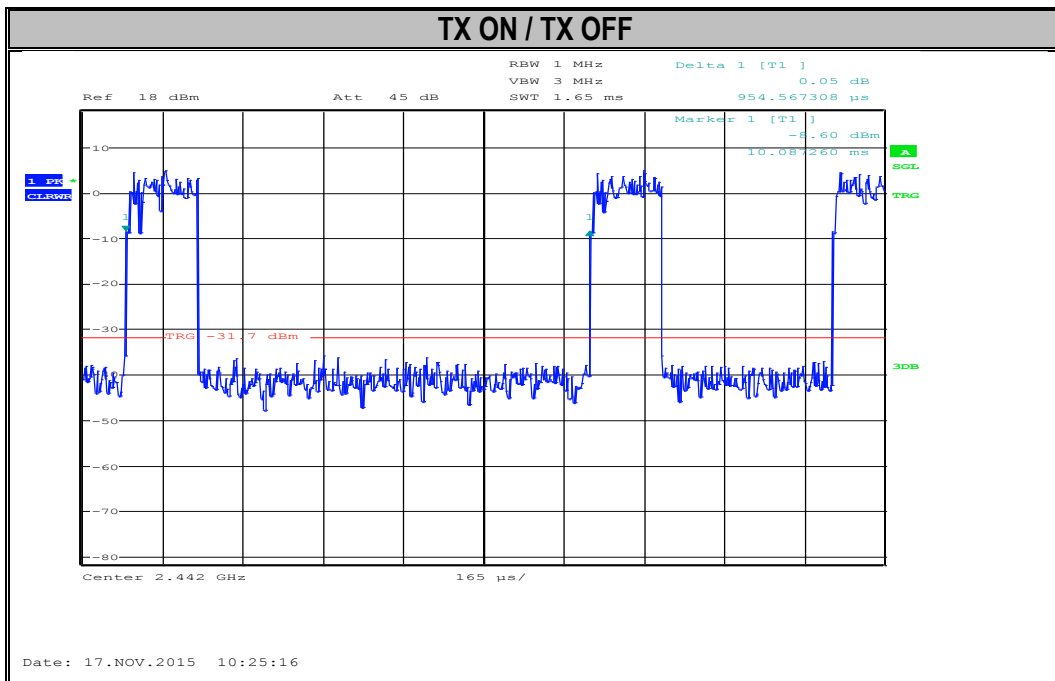
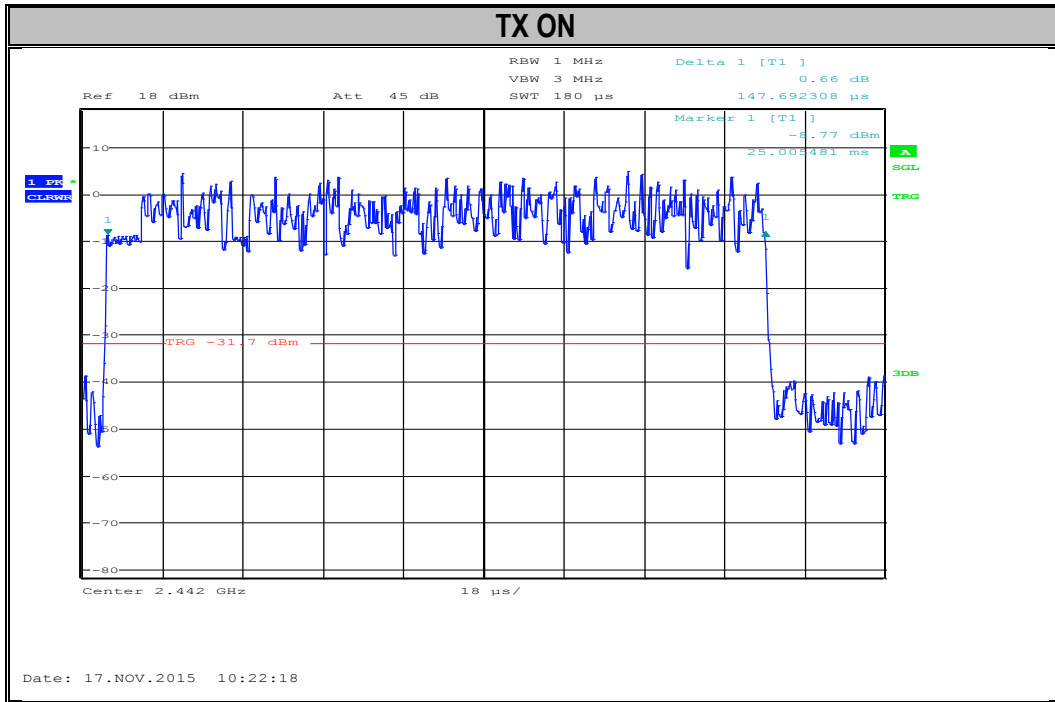

### 3.7.4 802.11n (MCS7)



Test Report #:	EMC_MOOGI-005-15001_15.247_WLAN	FCC ID: 2AGRZ-ILC3000	
Date of Report	January 27, 2015	Page 19 of 67	

#### 4 Subject of Investigation

The objective of the measurements done by CETECOM Inc. was to assess the performance of the EUT per the relevant requirements specified in FCC rules Part 15.247 of Title 47 of the Code of Federal Regulations and Radio Standard Specification RSS-247 of Industry Canada.

This test report is to support a request for new equipment authorization under the FCC ID: 2AGRZ-ILC3000. IC ID: 20942-ILC3000.

Testing procedures are based on  
558074 D01 DTS Meas Guidance v03r03  
ANSI C63.10 2013

#### 5 Measurement Results Summary

Test Specification	Test Case	Temperature and Voltage Conditions	Mode	Pass	Fail	NA	NP	Result
§15.247(e) RSS247 5.2(2)	Power Spectral Density	Nominal	Low , Mid, High channel	■	□	□	□	Complies
§15.247(a)(1) RSS247 5.2(1)	Emission Bandwidth	Nominal	All supported modulations Mid channel only	■	□	□	□	Complies
§15.247(b)(1) RSS247 5.4(4)	Maximum Conducted Output Power and EIRP	Nominal	Low , Mid, High channel	■	□	□	□	Complies
§15.247/15.209/ 15.205 RSS-Gen 8.9/ 8.10	Band edge compliance- Restricted Band Edges	Nominal	Low , High channel	■	□	□	□	Complies
§15.247(d) RSS247 5.5	Band edge compliance- Unrestricted Band Edges	Nominal	Low , High channel	■	□	□	□	Complies
§15.247(d) §15.209 RSS-Gen 6.13	TX Spurious emissions- Radiated	Nominal	Low , Mid, High channel	■	□	□	□	Complies
§15.207(a) RSS Gen 8.8	AC Conducted Emissions	Nominal	Mid channel	■	□	□	□	Complies

Note: NA= Not Applicable; NP= Not Performed.

## 6 Measurement Uncertainty

Where relevant, the following measurement uncertainty levels have been estimated for tests performed on the apparatus, with 95% confidence interval (in dB delta to result), based on a coverage factor k=1.

	Uncertainty in dB radiated <30MHz	Uncertainty in dB radiated 30MHz - 1GHz	Uncertainty in dB radiated > 1GHz	Uncertainty in dB Conducted measurement
<b>standard deviation k=1</b>	2.48	1.94	2.16	0.64
<b>95% confidence interval in dB</b>	4.86	3.79	4.24	1.25
<b>95% confidence interval in dB in delta to Result (rounded up to next decimal point)</b>	+/- 2.5 dB	+/- 2.0 dB	+/- 2.3dB	+/- 0.7dB

## 7 Environmental Conditions During Testing:

The following environmental conditions were maintained during the course of testing:

- Ambient Temperature: 20-25°C
- Relative humidity: 40-60%

## 8 Dates of Testing:

November 17, 2015 – December 21, 2015

## 9 Measurement Procedures

### 9.1 Radiated Measurement

The radiated measurement is performed according to:

ANSI C63.10 (2013)

- The exploratory measurement is accomplished by running sweeps at 1 and 4m antenna heights over the required frequency range with R&S Test-SW EMC32 for both antenna polarizations. During each frequency scan the turntable rotates by no more than 10deg.
- The 10 highest emissions are selected with an automatic algorithm of EMC32 searching for peaks in the noise floor and ensuring that broadband signals are not selected multiple times.
- The maxima are then again maximized through a fine search in frequency domain, maximized in the 360deg range of the turntable, and maximized over antenna height between 1m and 4m and for positioning of the EUT.
- The above procedure is repeated for transmission low mid and high channel.
- In case there are no emissions above noise floor level only the maximum trace is reported as described above.
- The results are split up into up to 4 frequency ranges due to antenna bandwidth restrictions. A magnetic loop is used from 9 kHz to 30 MHz, a Biconilog antenna is used from 30 MHz to 1 GHz, and two different horn antennas are used to cover frequencies up to 40 GHz.

#### Radiated Emissions Test Setup Below 30MHz Measurements

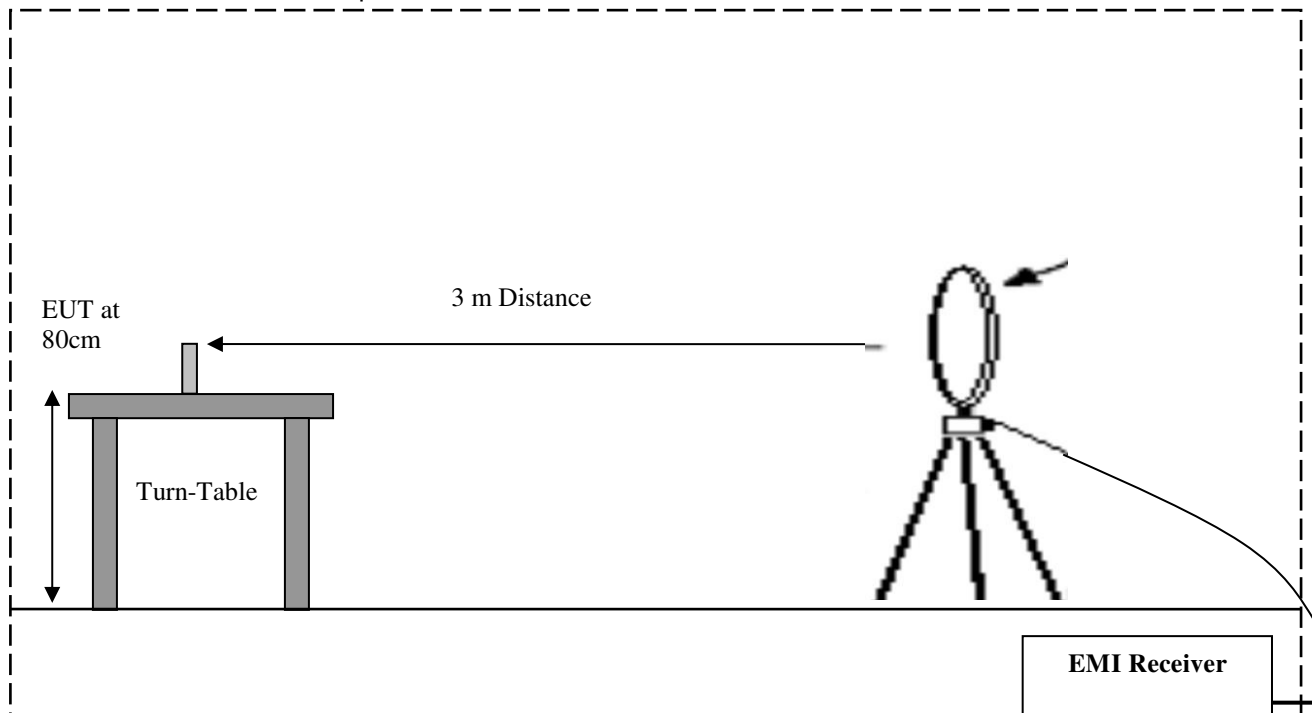

### Radiated Emissions Test Setup 30MHz-1GHz Measurements

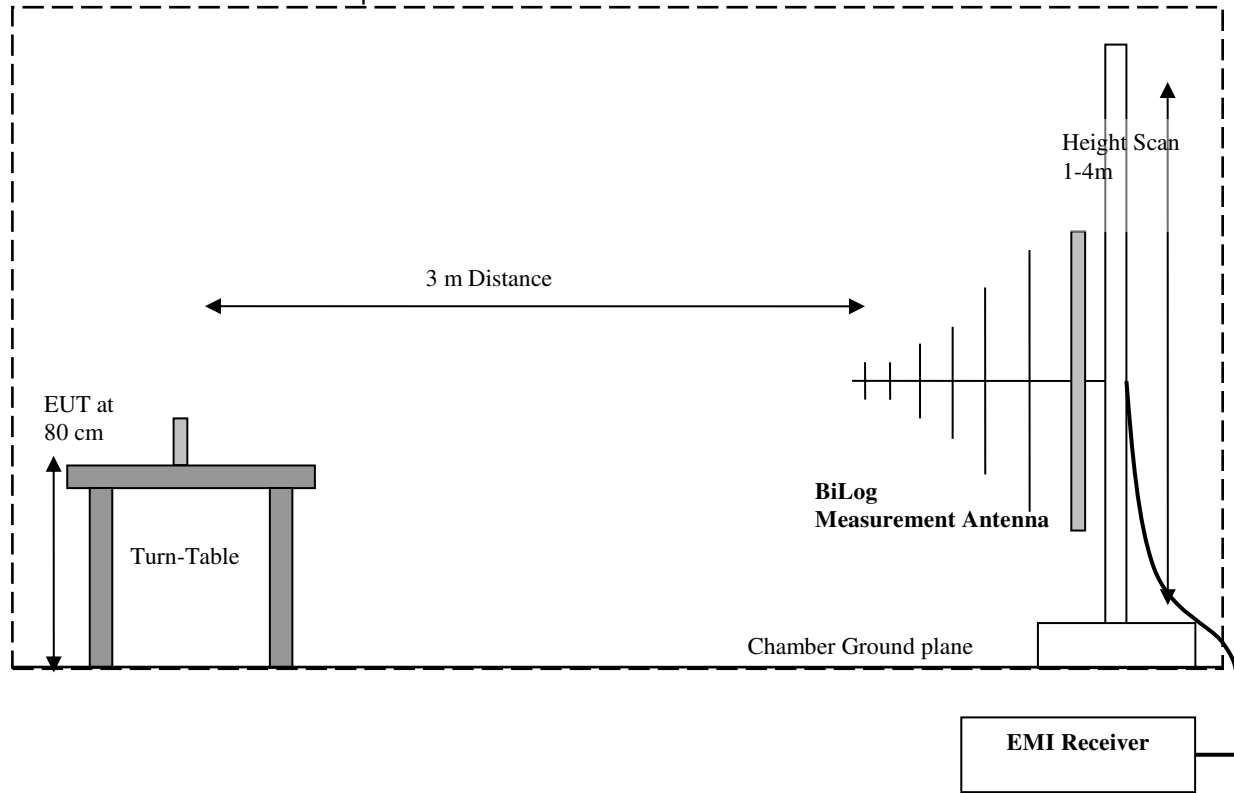

### Radiated Emissions Test Setup Above 1GHz Measurements

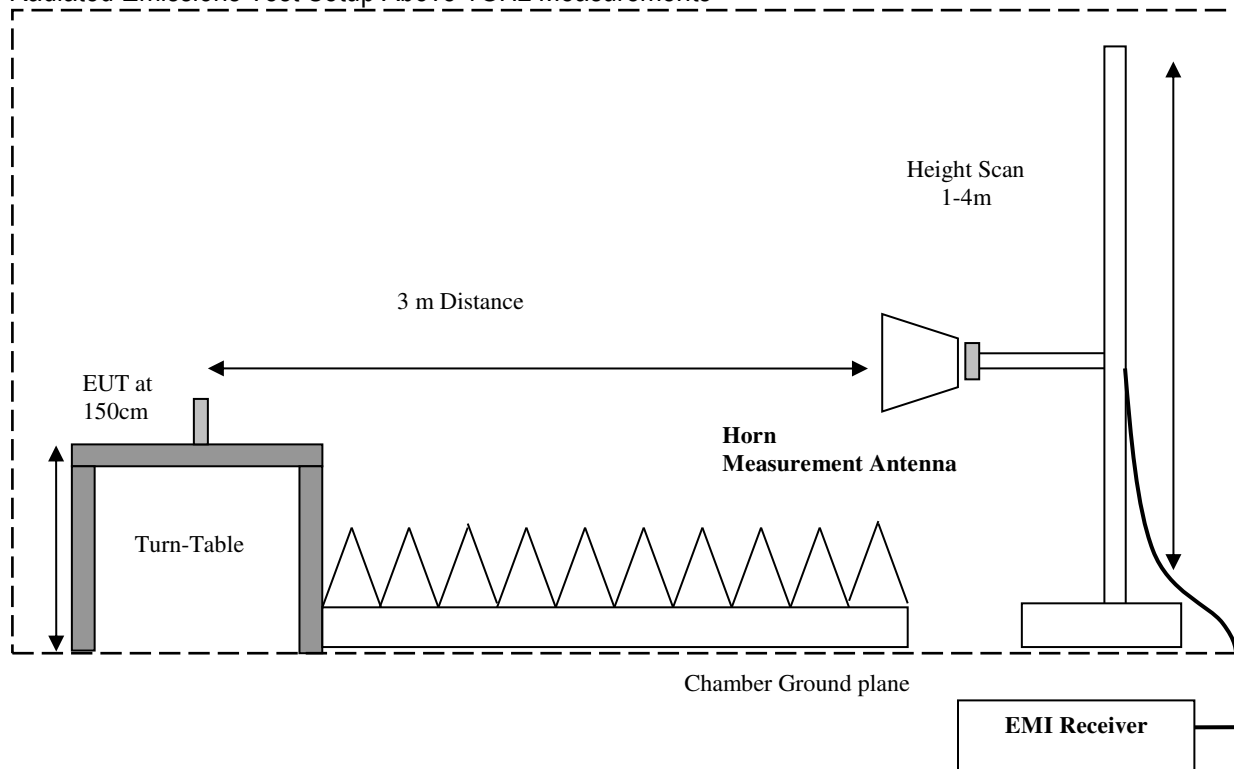

## 9.2 Sample Calculations for Field Strength Measurements

Field Strength is calculated from the Spectrum Analyzer/ Receiver readings, taking into account the following parameters:

1. Measured reading in dB $\mu$ V
2. Cable Loss between the receiving antenna and SA in dB and
3. Antenna Factor in dB/m

All radiated measurement plots in this report are taken from a test SW that calculates the Field Strength based on the following equation:

$$FS \text{ (dB}\mu\text{V/m)} = \text{Measured Value on SA (dB}\mu\text{V)} - \text{Cable Loss (dB)} + \text{Antenna Factor (dB/m)}$$

Example:

Frequency (MHz)	Measured SA (dB $\mu$ V)	Cable Loss (dB)	Antenna Factor Correction (dB)	Field Strength Result (dB $\mu$ V/m)
1000	80.5	3.5	14	98.0

## 9.3 Power Line Conducted Measurement Procedure

AC Power Line conducted emissions measurements performed according to:

ANSI C63.4 (2014)

## 9.4 RF Conducted Measurement Procedure

### 9.4.1 Conducted Measurement Setup without companion device

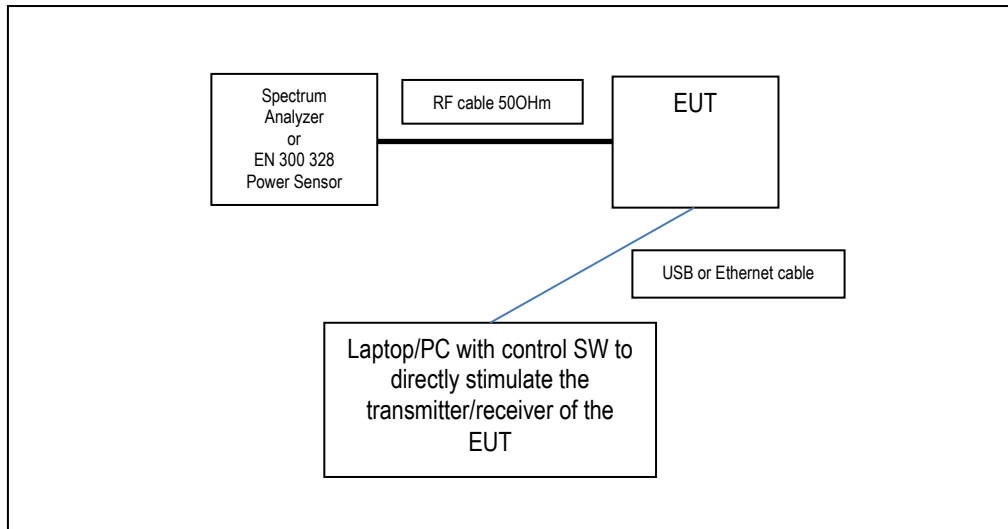



## 10 Maximum Conducted Average Output Power

10.1 Measurement according to FCC KDB 558074 D01 V03R03, Method AVGSA-2 Section 9.2.2.4

### Spectrum Analyzer settings:

- a) Measure the duty cycle,  $x$ , of the transmitter output signal as described in 6.0.
- b) Set span to at least 1.5 times the OBW.
- c) Set RBW = 1-5% of the OBW, not to exceed 1 MHz.
- d) Set VBW  $\geq 3 \times$  RBW.
- e) Number of points in sweep  $\geq 2 \times$  span / RBW. (This gives bin-to-bin spacing  $\leq$  RBW/2, so that narrowband signals are not lost between frequency bins.)
- f) Sweep time = auto.
- g) Detector = RMS (*i.e.*, power averaging), if available. Otherwise, use sample detector mode.
- h) Do not use sweep triggering. Allow the sweep to "free run".
- i) Trace average at least 100 traces in power averaging (*i.e.*, RMS) mode; however, the number of traces to be averaged shall be increased above 100 as needed such that the average accurately represents the true average over the on and off periods of the transmitter.
- j) Compute power by integrating the spectrum across the OBW of the signal using the instrument's band power measurement function with band limits set equal to the OBW band edges. If the instrument does not have a band power function, sum the spectrum levels (in power units) at intervals equal to the RBW extending across the entire OBW of the spectrum.
- k) Add  $10 \log(1/x)$ , where  $x$  is the duty cycle, to the measured power in order to compute the average power during the actual transmission times (because the measurement represents an average over both the on and off times of the transmission). For example, add  $10 \log(1/0.25) = 6$  dB if the duty cycle is 25 %.

10.2 Limits:

### Maximum Peak Output Power:

FCC §15.247 (b)(1): 1W

IC RSS-247: 1W

### EIRP:

IC RSS-247: 4W

10.3 Test conditions and setup:

Ambient Temperature	EUT Set-Up #	EUT operating mode	Power Input
23° C	2	Tx	Battery, 3.8V DC

10.4 Measurement result:

Plot #	Frequency (MHz)	Maximum Average Conducted Output Power (dBm)	Duty Cycle Correction (dB)	Antenna Gain (dBi)	EIRP (dBm)	Limit (dBm)	Result
1	2412	13.71	+1.1	+2.5	17.3	30(Pk) / 36(EIRP)	Pass
2	2442	15.72	+1.1	+2.5	19.3	30(Pk) / 36(EIRP)	Pass
3	2462	14.1	+1.1	+2.5	17.7	30(Pk) / 36(EIRP)	Pass

10.5 Measurement Plots:

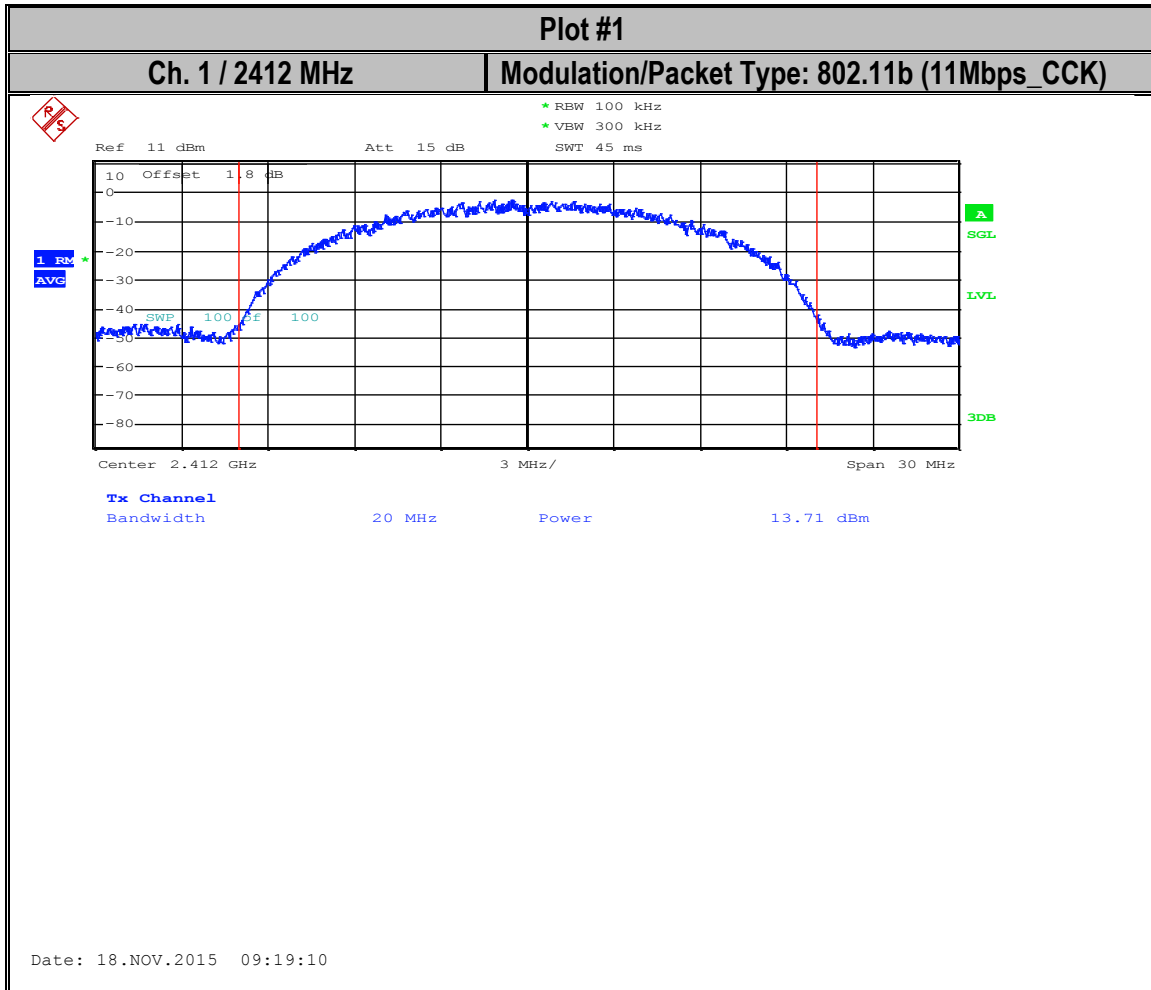

Note: Average output power already compensated for duty cycle correction factor.

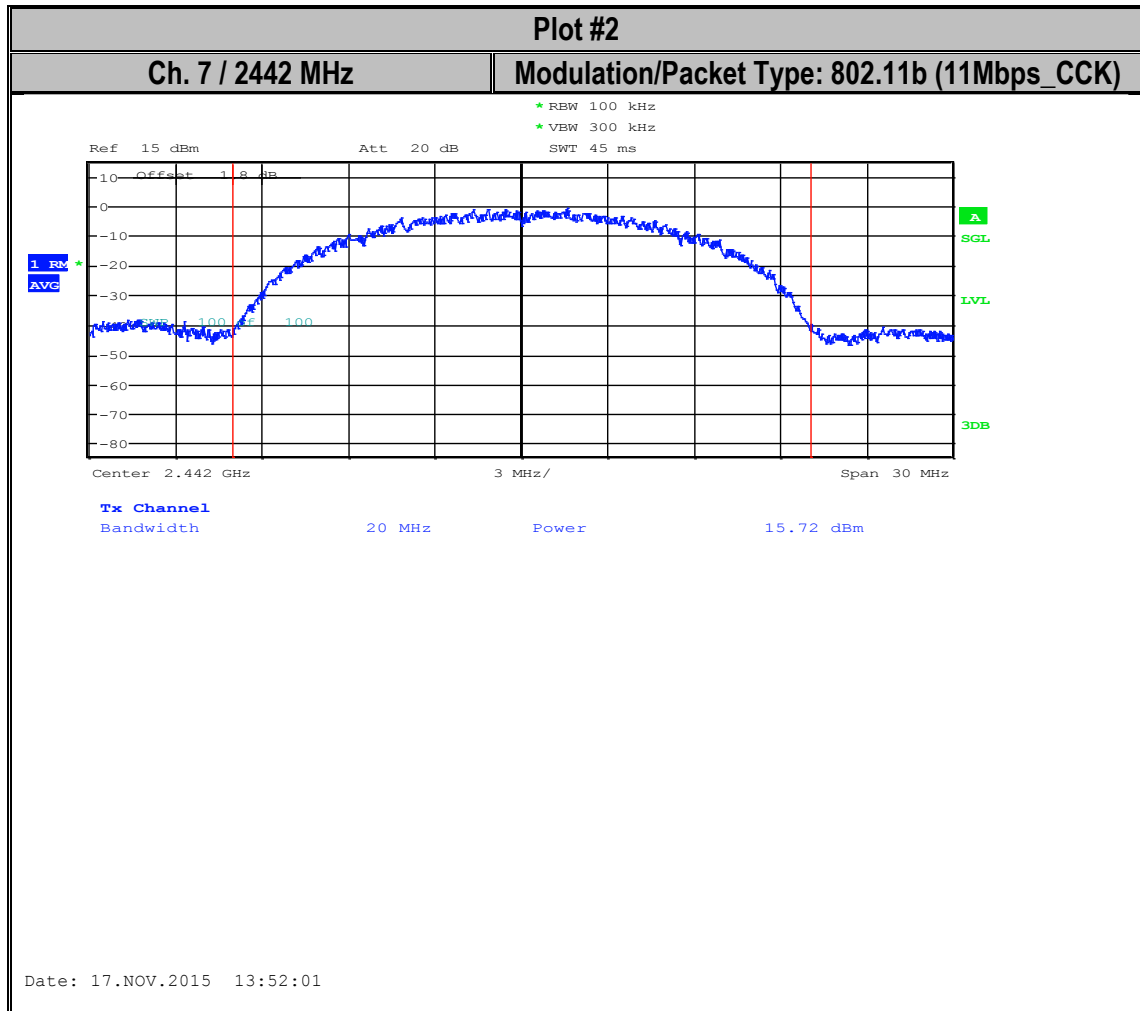

Note: Average output power already compensated for duty cycle correction factor.

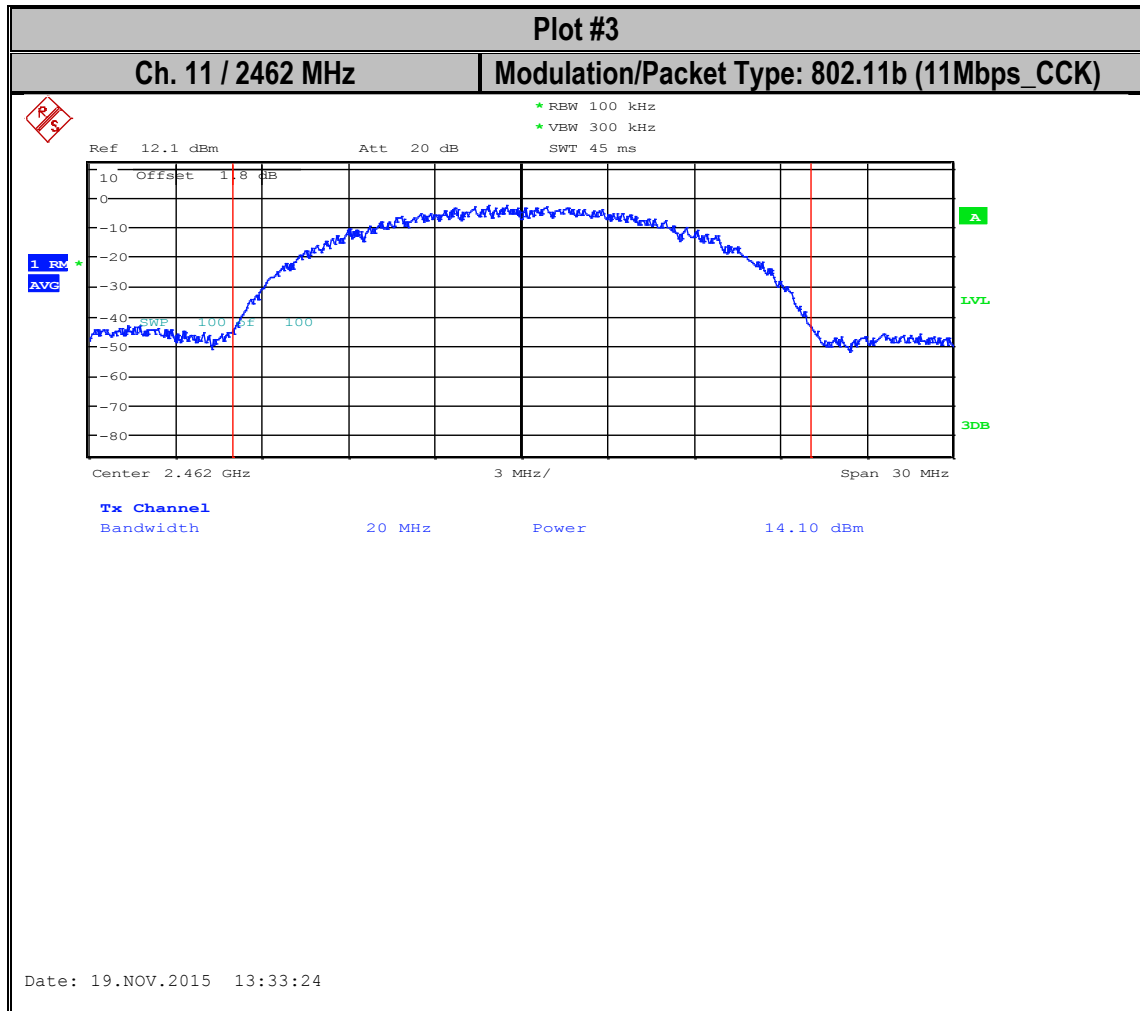

Note: Average output power already compensated for duty cycle correction factor.

## 11 Power Spectral Density

11.1 Measurement according to FCC KDB 558074 D01 V03R03

### Spectrum Analyzer settings for Peak PSD method:

Set analyzer center frequency to DTS channel center frequency.

Set the span to 1.5 times the DTS bandwidth

Set RBW to:  $3 \text{ kHz} \leq \text{RBW} \leq 100 \text{ kHz}$ .

Set the VBW  $\geq 3 \times \text{RBW}$ .

Detector = peak.

Sweep time = auto couple.

Trace mode = max hold.

Allow trace to fully stabilize.

Use the peak marker function to determine the maximum amplitude level within the RBW.

If measured value exceeds limit, reduce RBW (no less than 3 kHz) and repeat.

11.2 Limits: §15.247 & RSS-247

For digitally modulated systems, the peak power spectral density conducted from the intentional radiator to the antenna shall not be greater than 8 dBm in any 3 kHz band during any time interval of continuous transmission.

11.3 Test conditions and setup:

Ambient Temperature	EUT Set-Up #	EUT Operating Mode	Power Input
23° C	2	Tx	Battery, 3.8V DC

11.4 Measurement result:

Plot #	Frequency (MHz)	Maximum Power Spectral Density (dBm/3kHz)	Limit ( dBm / 3 KHz )	Result
1	2412	-8.76	8	Pass
2	2442	-7.2	8	Pass
3	2462	-8.68	8	Pass

11.5 Measurement Plots:

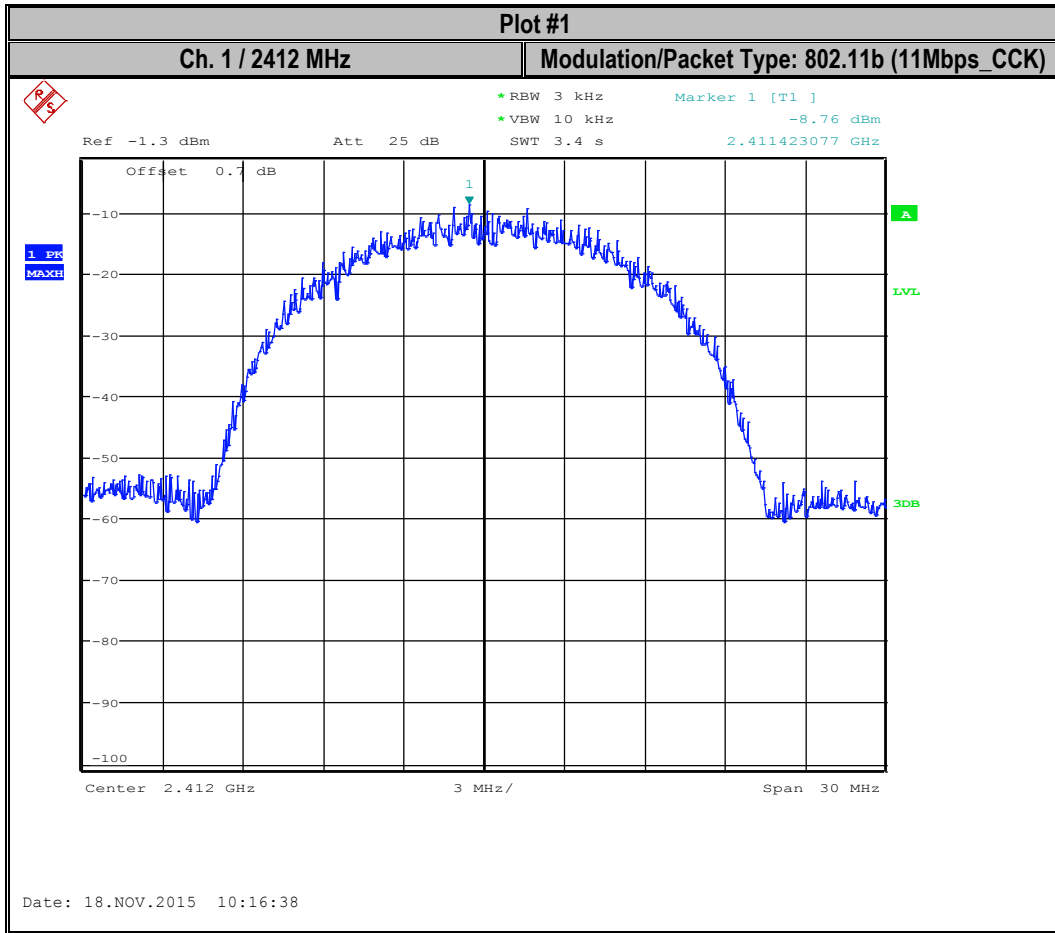

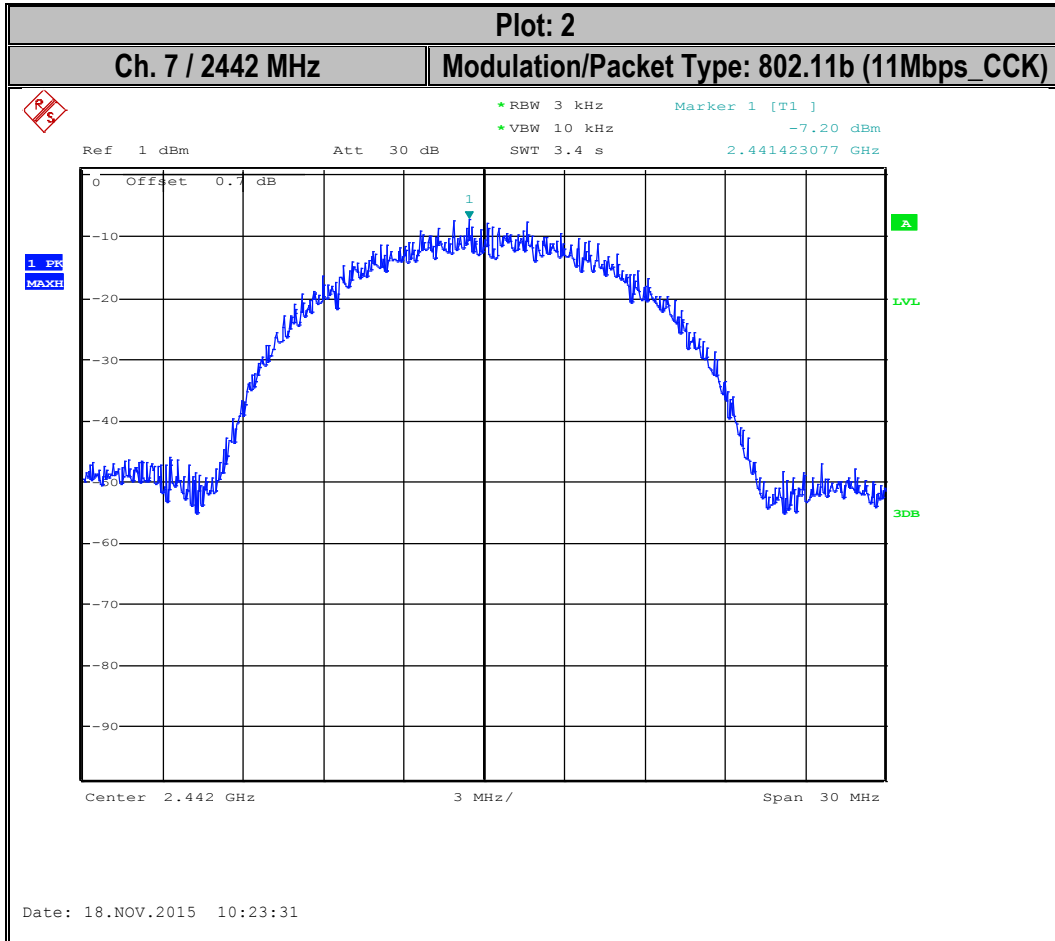



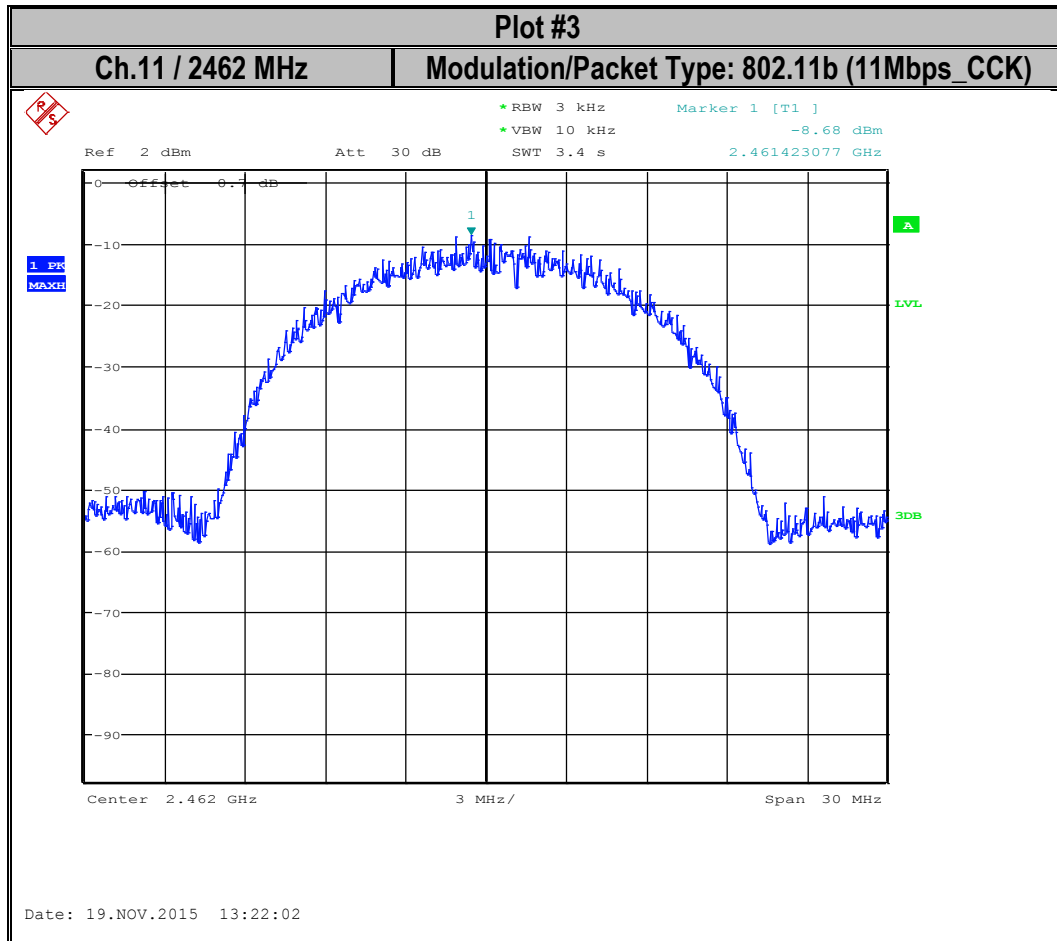

## 12 Band Edge Compliance

### 12.1 Measurement according to FCC KDB 558074 D01 v03r03

#### Spectrum Analyzer settings for band edge:

Set the center frequency and span to encompass frequency range to be measured

RBW ≥ 100 kHz

VBW ≥ RBW

Sweep Time: Auto

Detector = peak

Trace = max hold

Allow trace to fully stabilize

Use the peak marker function to determine the maximum amplitude level

Allow the trace to stabilize. Set the marker on the emission at the band edge, or on the highest modulation product outside of the band, if this level is greater than that at the band edge.

### 12.2 Limits restricted band §15.205 and RSS-Gen 8.10

\*PEAK LIMIT= 74dBμV/m @3m =-21.23dBm

\*AVG. LIMIT= 54dBμV/m @3m =-41.23dBm

Start frequency & stop frequency according to frequency range specified in the restricted band table in FCC section 15.205 & RSS-Gen 8.10

Measurements with a peak detector were used to show compliance to average limits, thus showing compliance to both peak and average limits.

- (a) Except as shown in paragraph (d) of this section, only spurious emissions are permitted in any of the frequency bands listed below:

MHz	MHz	MHz	GHz
0.090 - 0.110	16.42 - 16.423	399.9 - 410	4.5 - 5.15
<sup>1</sup> 0.495 - 0.505	16.69475 - 16.69525	608 - 614	5.35 - 5.46
2.1735 - 2.1905	16.80425 - 16.80475	960 - 1240	7.25 - 7.75
4.125 - 4.128	25.5 - 25.67	1300 - 1427	8.025 - 8.5
4.17725 - 4.17775	37.5 - 38.25	1435 - 1626.5	9.0 - 9.2
4.20725 - 4.20775	73 - 74.6	1645.5 - 1646.5	9.3 - 9.5
6.215 - 6.218	74.8 - 75.2	1660 - 1710	10.6 - 12.7
6.26775 - 6.26825	108 - 121.94	1718.8 - 1722.2	13.25 - 13.4
6.31175 - 6.31225	123 - 138	2200 - 2300	14.47 - 14.5
8.291 - 8.294	149.9 - 150.05	2310 - 2390	15.35 - 16.2
8.362 - 8.366	156.52475 - 156.52525	2483.5 - 2500	17.7 - 21.4
8.37625 - 8.38675	156.7 - 156.9	2690 - 2900	22.01 - 23.12
8.41425 - 8.41475	162.0125 - 167.17	3260 - 3267	23.6 - 24.0
12.29 - 12.293	167.72 - 173.2	3332 - 3339	31.2 - 31.8
12.51975 - 12.52025	240 - 285	3345.8 - 3358	36.43 - 36.5
12.57675 - 12.57725	322 - 335.4	3600 - 4400	( <sup>2</sup> )
13.36 - 13.41			

Test Report #:	EMC_MOOGI-005-15001_15.247_WLAN	FCC ID: 2AGRZ-ILC3000	
Date of Report	January 27, 2015	Page 35 of 67	

### 12.3 Limits non restricted band §15.247 and RSS-247 5.5

#### **FCC15.247 (d)**

In any 100 kHz bandwidth outside the frequency band in which the spread spectrum or digitally modulated intentional radiator is operating, the radio frequency power that is produced by the intentional radiator shall be at least 20 dB below that in the 100 kHz bandwidth within the band that contains the highest level of the desired power, based on either an RF conducted or a radiated measurement, provided the transmitter demonstrates compliance with the peak conducted power limits. If the transmitter complies with the conducted power limits based on the use of RMS averaging over a time interval, as permitted under paragraph (b)(3) of this section, the attenuation required under this paragraph shall be 30 dB instead of 20 dB. Attenuation below the general limits specified in §15.209(a) is not required. In addition, radiated emissions which fall in the restricted bands, as defined in §15.205(a), must also comply with the radiated emission limits specified in §15.209(a) (see §15.205(c)).

#### **RSS-247 5/5**

In any 100 kHz bandwidth outside the frequency band in which the spread spectrum or digitally modulated intentional radiator is operating, the radio frequency power that is produced by the intentional radiator shall be at least 20 dB below that in the 100 kHz bandwidth within the band that contains the highest level of the desired power, based on either an RF conducted or a radiated measurement, provided the transmitter demonstrates compliance with the peak conducted power limits. If the transmitter complies with the conducted power limits based on the use of RMS averaging over a time interval, as permitted under paragraph (b)(3) of this section, the attenuation required under this paragraph shall be 30dB instead of 20dB.

### 12.4 Test conditions and setup:

Ambient Temperature	EUT Set-Up #	EUT operating mode	Power Input
23° C	2	Tx	Battery, 3.8V DC

12.5 Measurement result:

Plot #	EUT operating mode	Band Edge	Band Edge Delta (dBc)	Limit (dBc) in case average output power was measured	Result
1	802.11b (11Mbps)	Lower, non-restricted	-38.24	-30	Pass
2	802.11n (MCS7)	Lower, non-restricted	-30.37	-30	Pass

Plot #	EUT operating mode	Band Edge	Measured value	Corrected by Duty Cycle Correction Factor (dBm)	Corrected by Antenna Gain (dBi)	Limit (dBm)	Result
3	802.11b (11Mbps)	Upper restricted peak	-35.22	1.1	2.5	-21.23 peak	Pass
4	802.11b (11Mbps)	Upper restricted average	-52.96	1.1	2.5	-41.23 average	Pass
5	802.11n (MCS7)	Upper restricted peak	-36.09	8.1	2.5	-21.23 peak	Pass
6	802.11n (MCS7)	Upper restricted average	-72.08	8.1	2.5	-41.23 average	Pass

12.6 Measurement Plots:

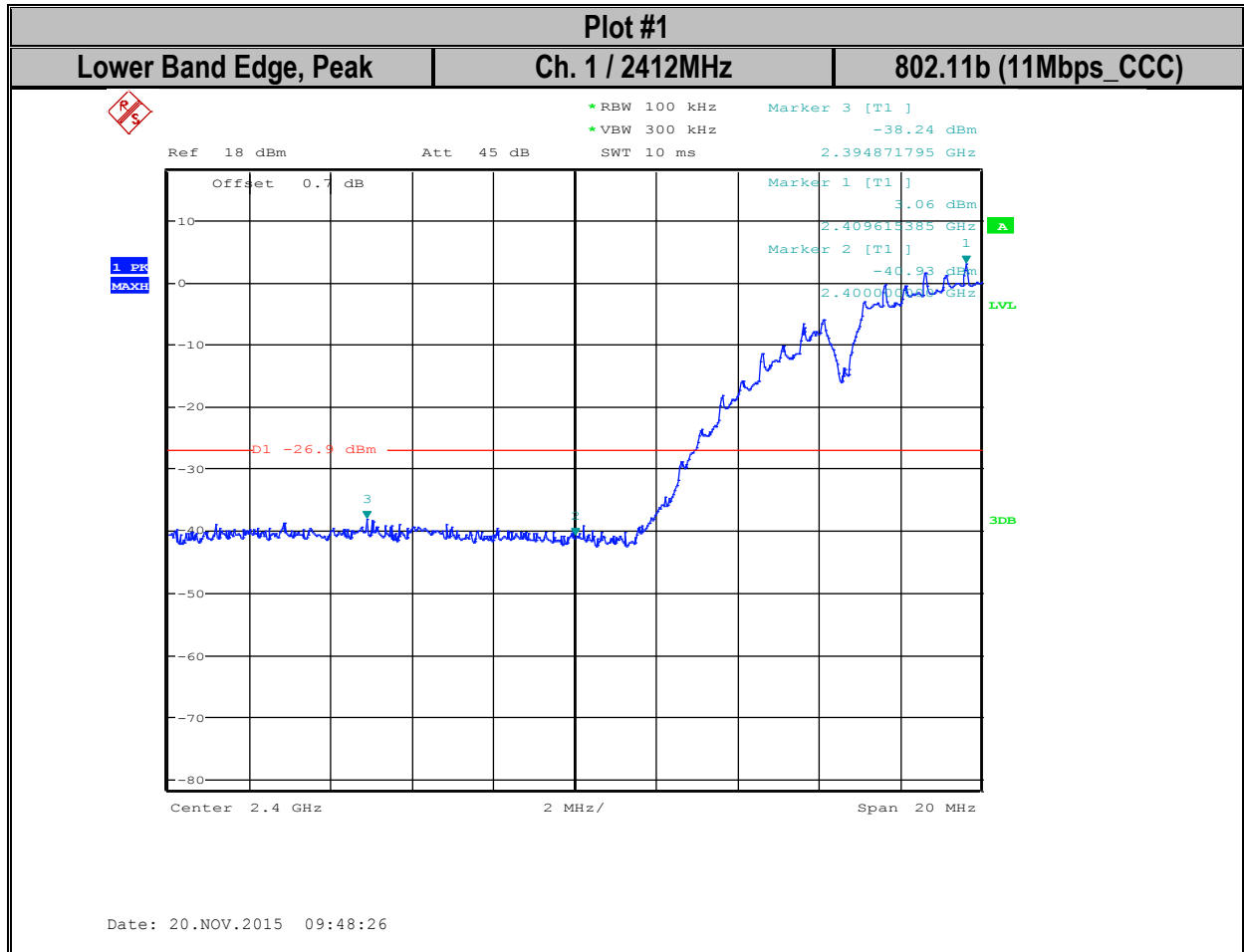

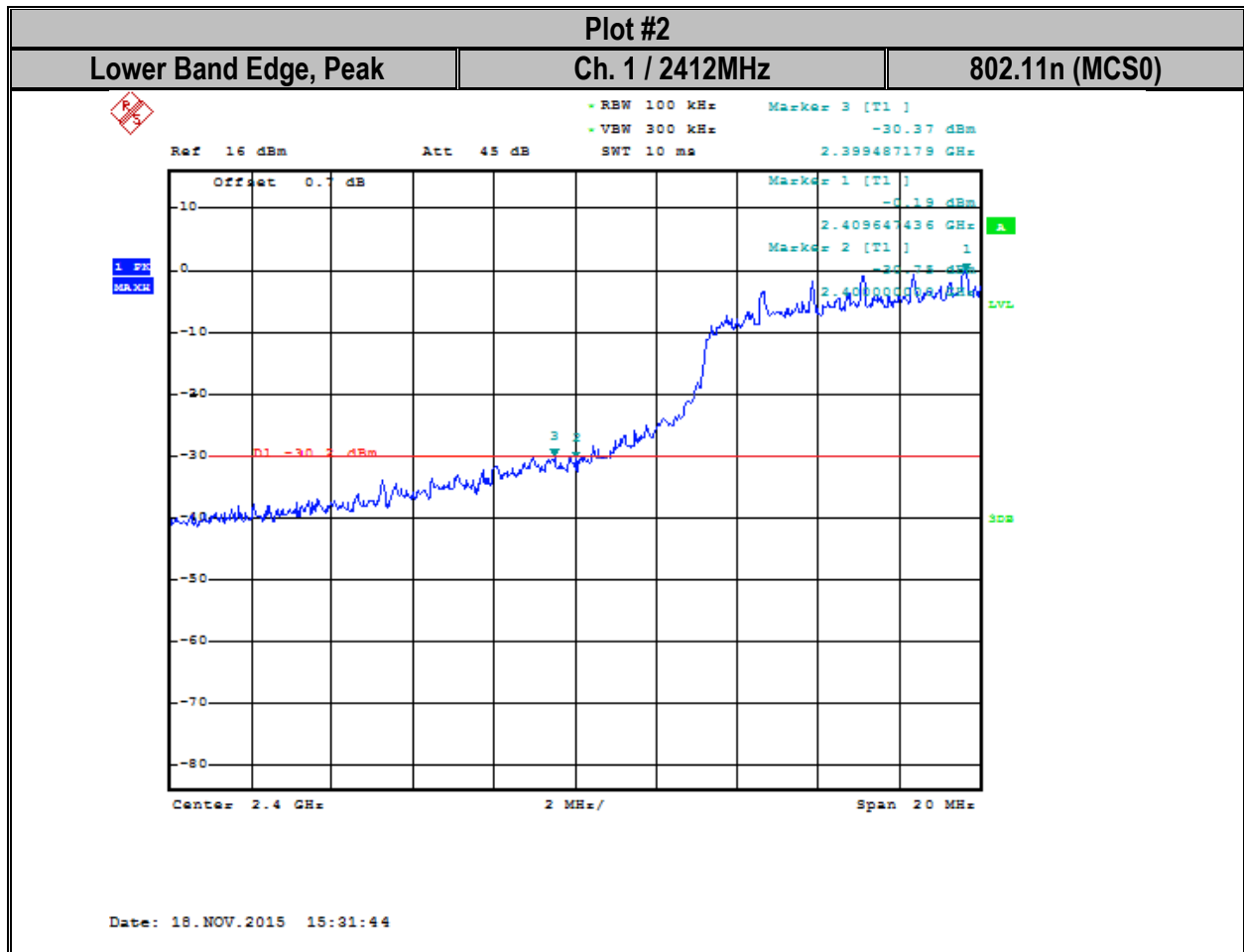

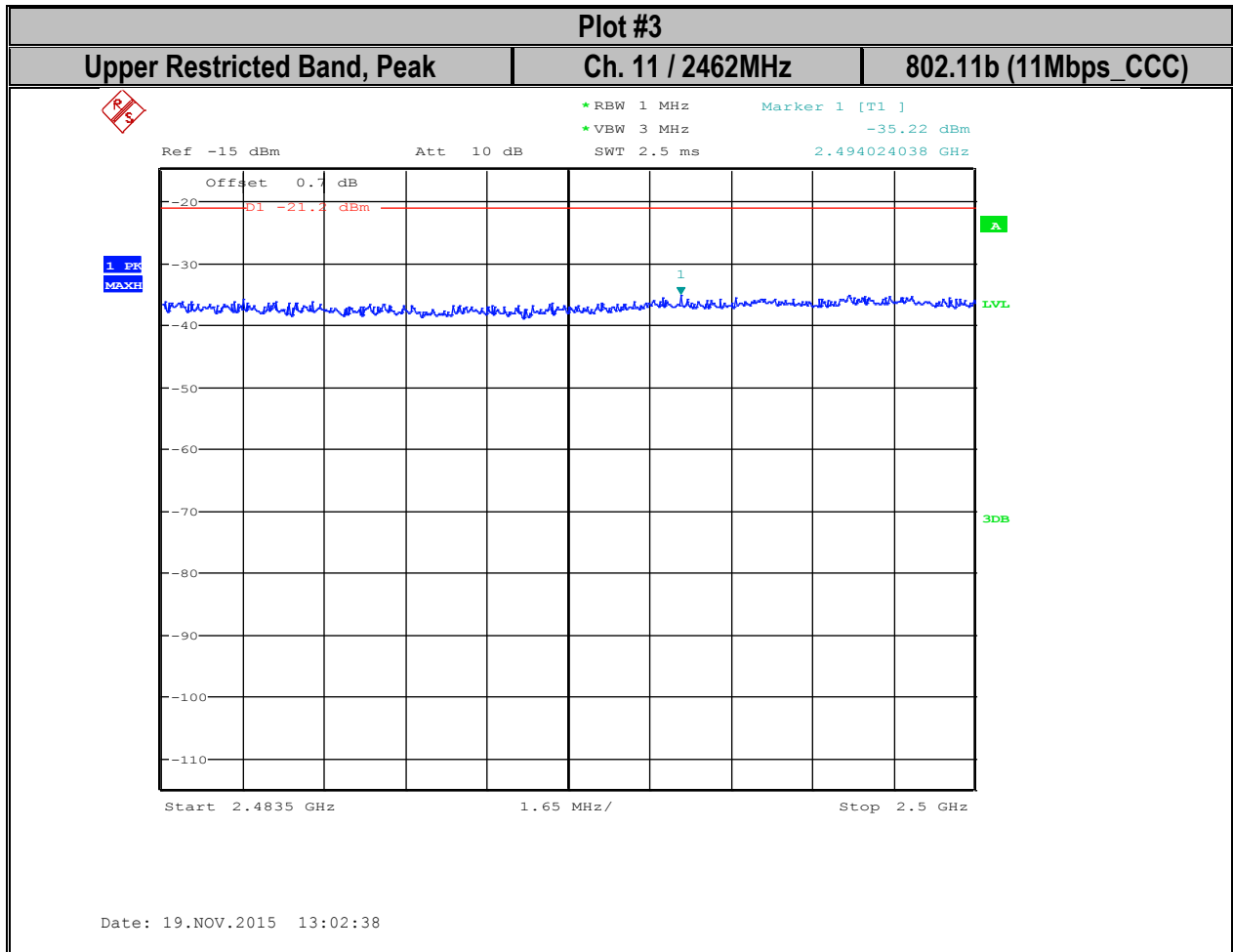

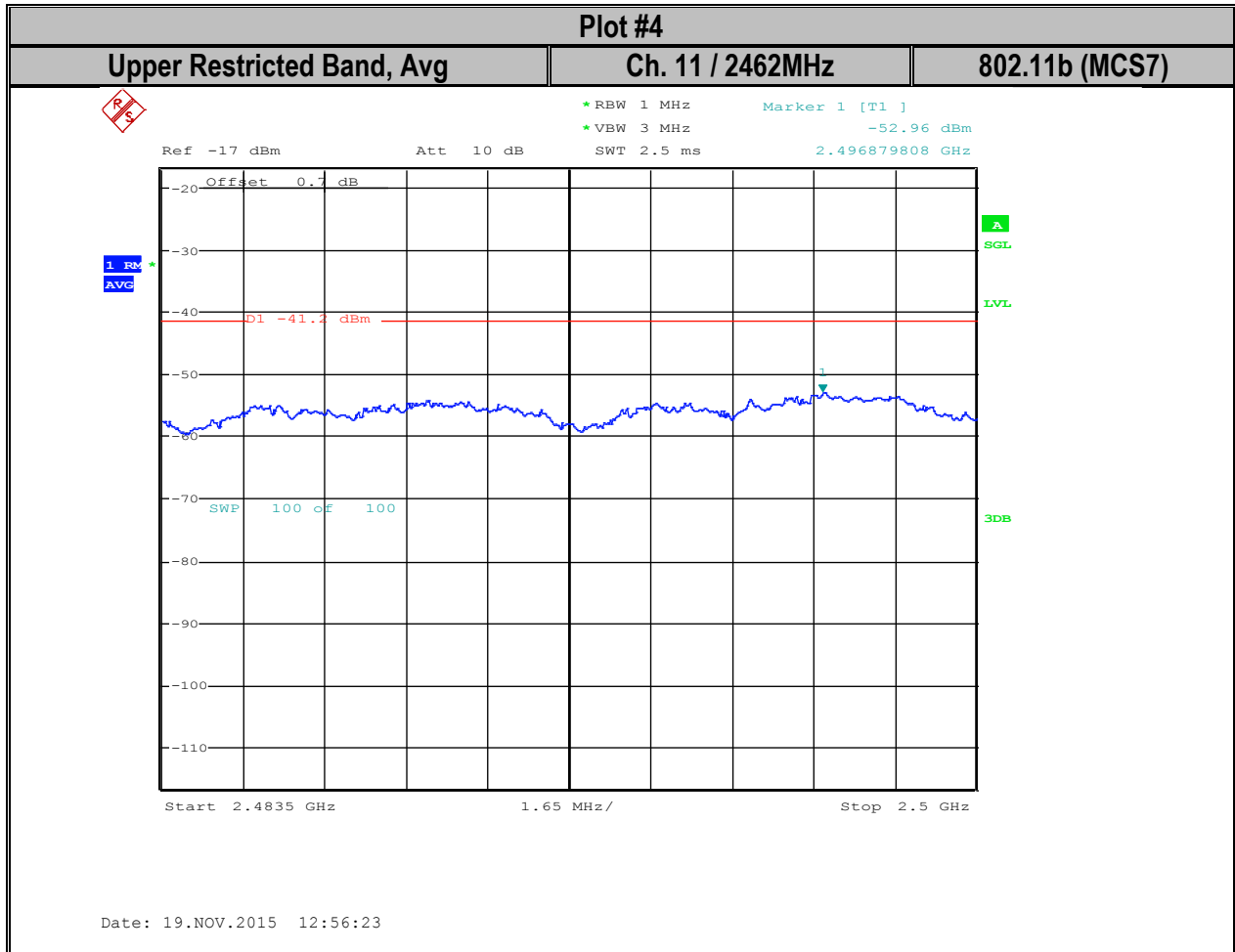



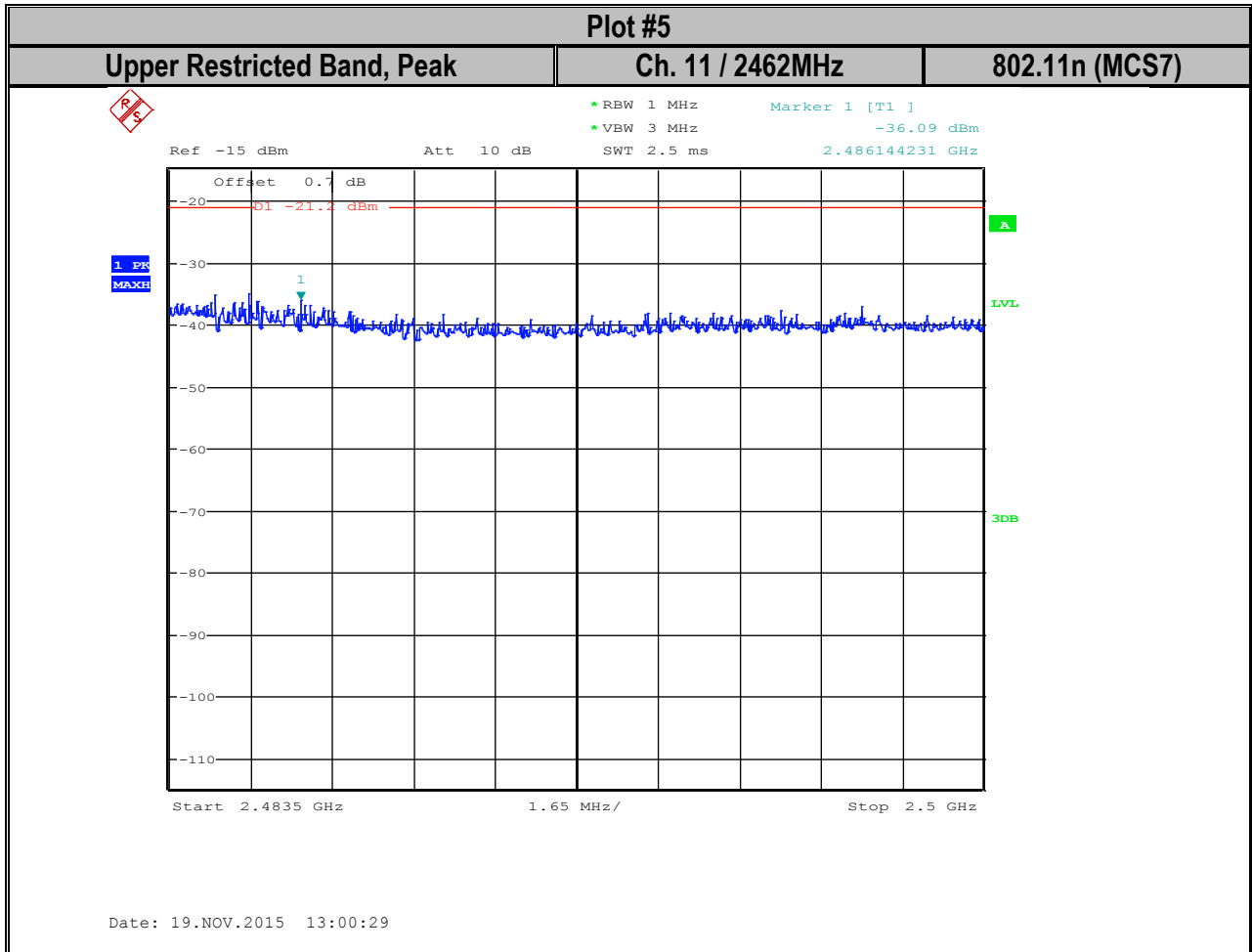

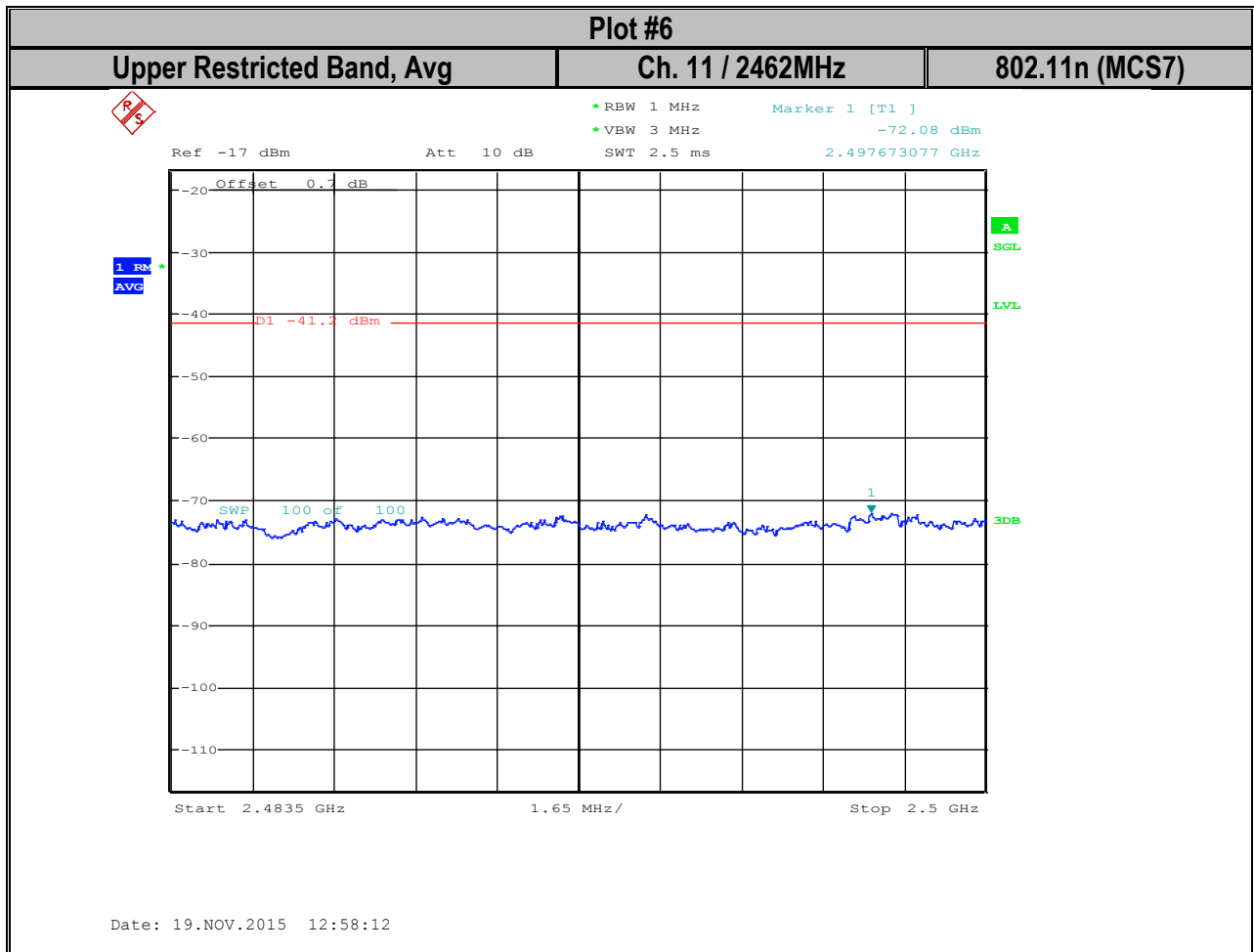



Test Report #:	EMC_MOOGI-005-15001_15.247_WLAN	FCC ID: 2AGRZ-ILC3000	
Date of Report	January 27, 2015	Page 43 of 67	

### 13 Emission Bandwidth 6dB and 99% Occupied Bandwidth

#### 13.1 Measurement according to FCC KDB 558074 D01 v03r03

##### Spectrum Analyzer settings:

Set RBW = 100 kHz

Set the video bandwidth (VBW)  $\geq 3 \times$  RBW

Detector = Peak

Trace mode = max hold

Sweep = auto couple

Allow the trace to stabilize

Measure the maximum width of the emission that is constrained by the frequencies associated with the two outermost amplitude points (upper and lower frequencies) that are attenuated by 6 dB relative to the maximum level measured in the fundamental emission.

#### 13.2 Limits: §15.247

Systems using digital modulation techniques may operate in the 902–928 MHz, 2400–2483.5 MHz, and 5725–5850 MHz bands. The minimum 6 dB bandwidth shall be at least 500 kHz.

#### 13.3 Test conditions and setup:

Ambient Temperature	EUT Set-Up #	EUT operating mode	Power Input
23° C	2	Tx	Battery, 3.8V DC

#### 13.4 Measurement result:

Plot #	Channel	Frequency (MHz)	Modulation / Bandwidth	6dB Emissions Bandwidth (MHz)	Limit (MHz)	Result
1	Ch. 7	2442	802.11 (1Mbps_DSSS)	6.78	> 0.5	Pass
2	Ch. 7	2442	802.11b (11Mbps_CCK)	7.88	> 0.5	Pass
3	Ch. 7	2442	802.11n (MCS0)	8.46	> 0.5	Pass
4	Ch. 7	2442	802.11n (MCS7)	17.74	> 0.5	Pass

Plot #	Channel	Frequency (MHz)	Modulation / Bandwidth	99% Occupied Bandwidth (MHz)
1	Ch. 7	2442	802.11 (1Mbps_DSSS)	13.99
2	Ch. 7	2442	802.11b (11Mbps_CCK)	14.23
3	Ch. 7	2442	802.11n (MCS0)	17.59
4	Ch. 7	2442	802.11n (MCS7)	17.69

13.5 Measurement Plots:

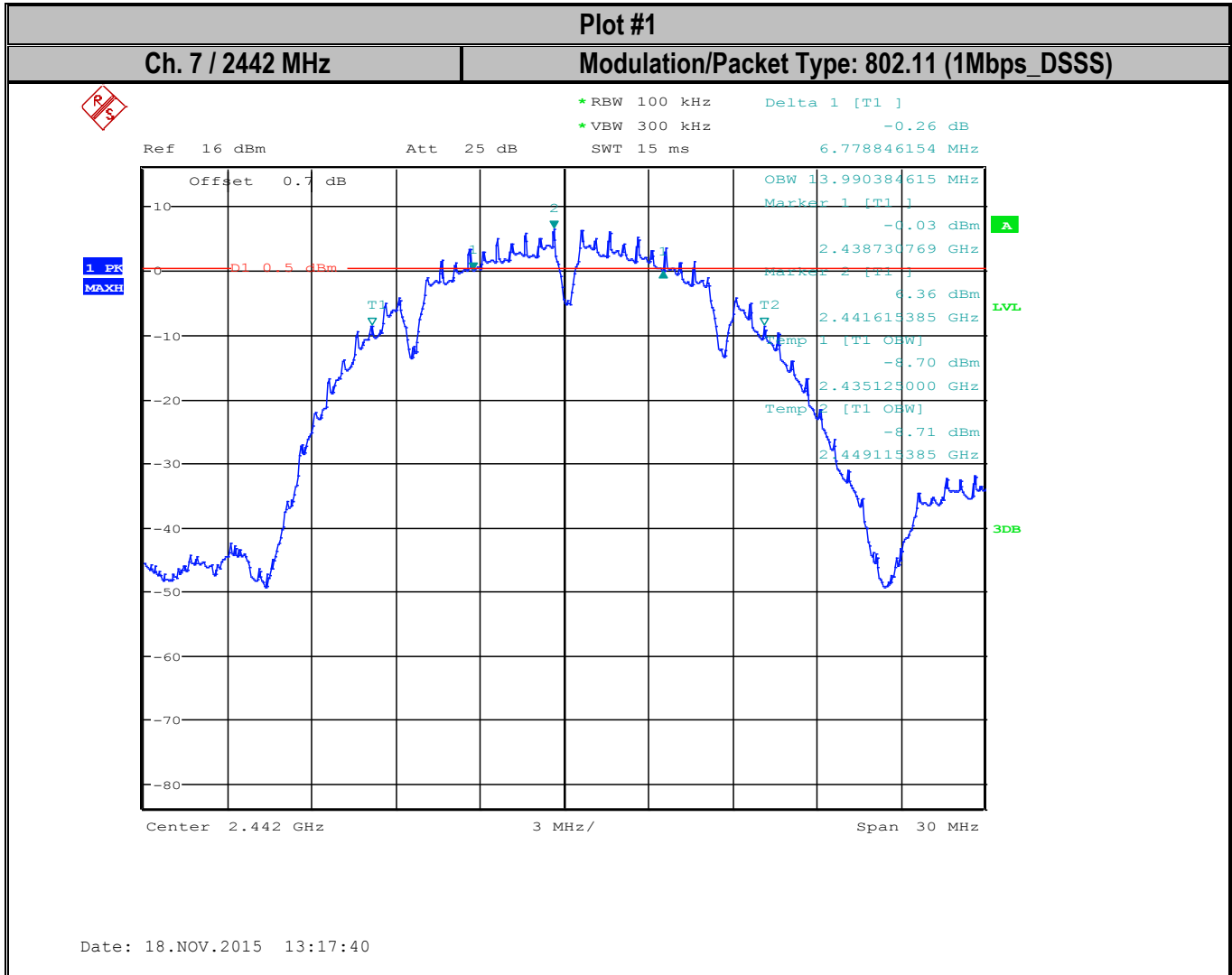

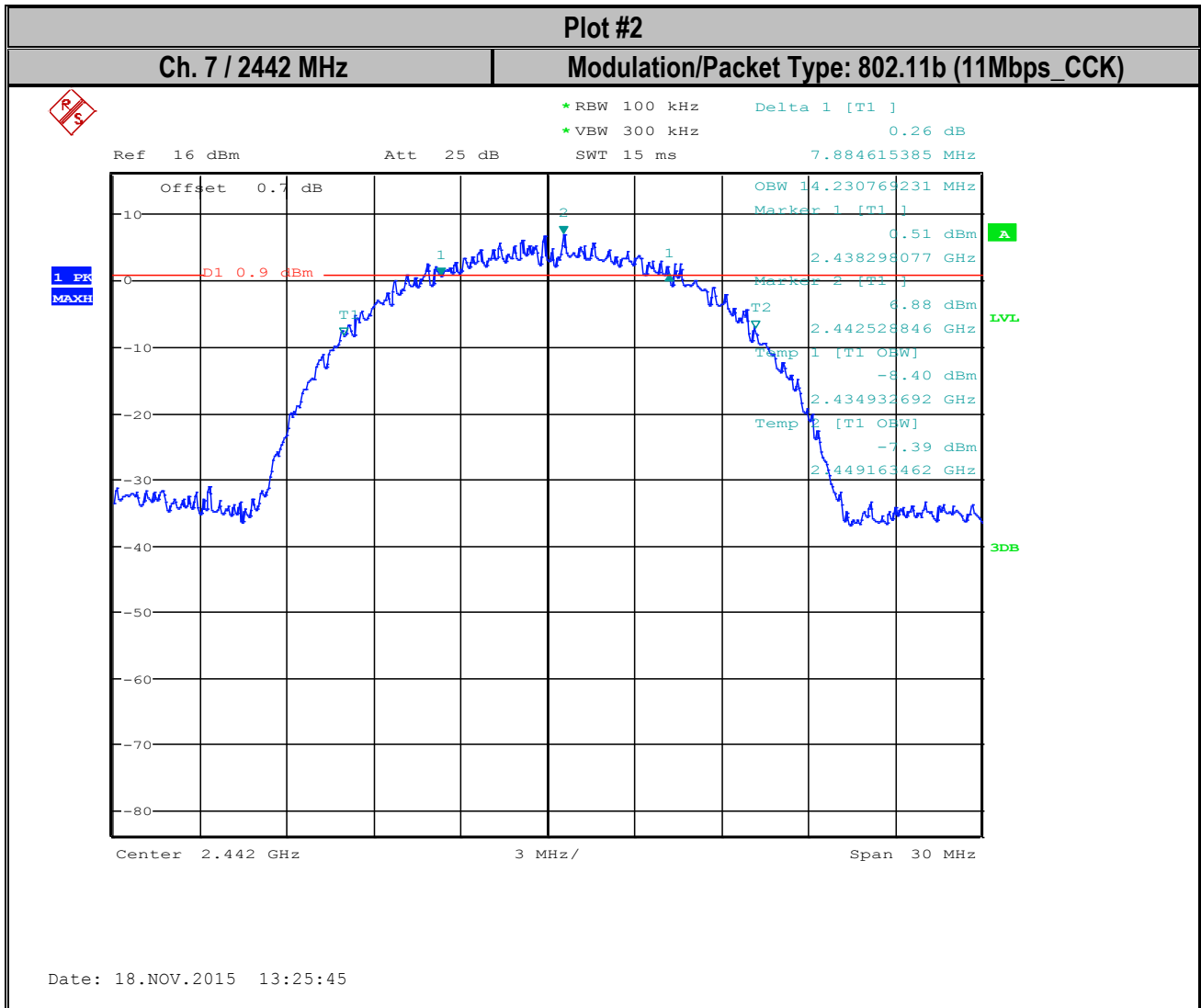

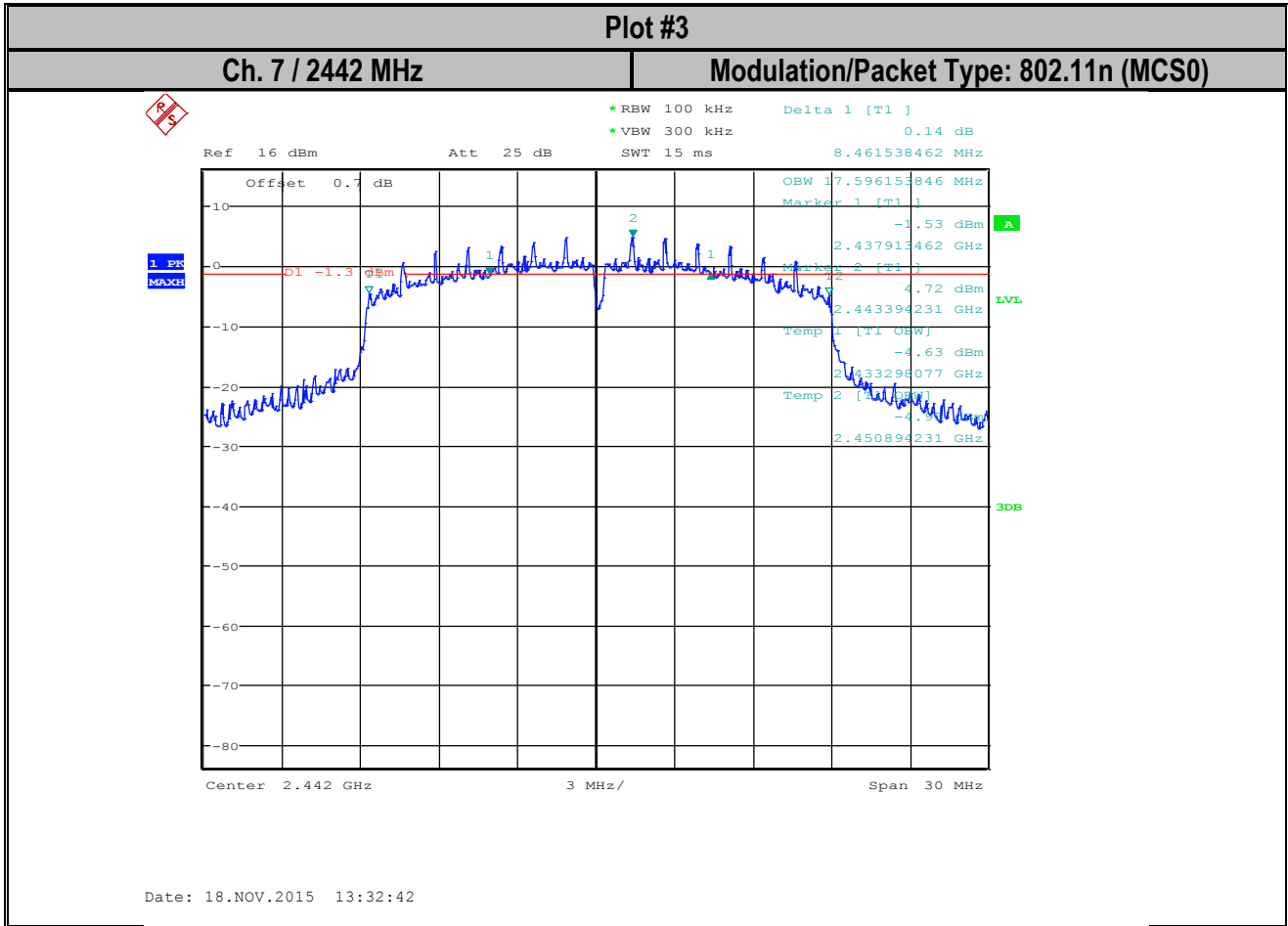

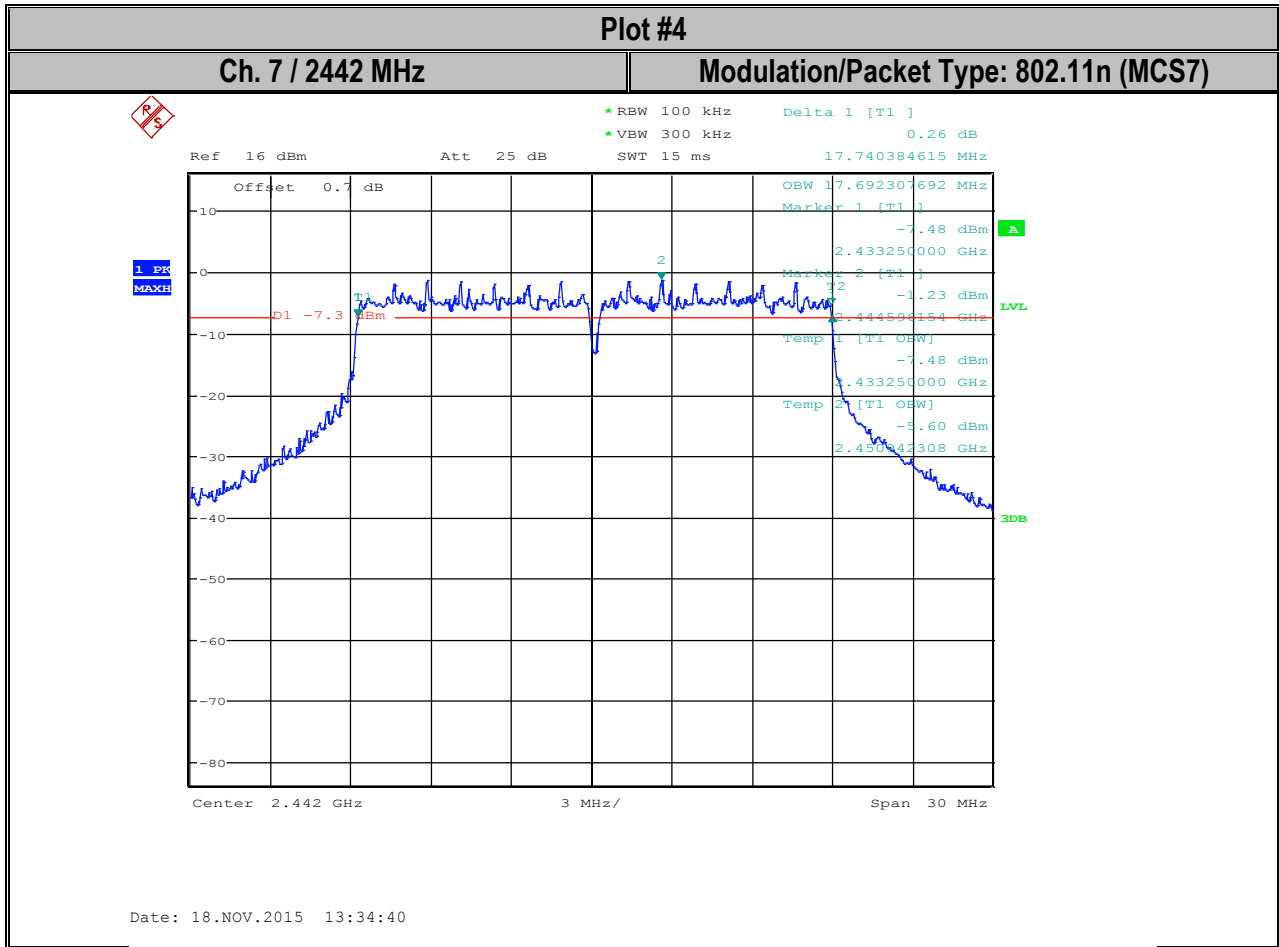

## 14 Radiated Transmitter Spurious Emissions and Restricted Bands

### 14.1 Measurement according to ANSI C63.10 (2013)

#### **Analyzer Settings:**

Frequency = 9 KHz – 30 MHz

RBW = 9 KHz

Detector: Peak

Frequency = 30 MHz – 1 GHz

Detector = Peak / Quasi-Peak

RBW=120 KHz (<1GHz)

Frequency > 1 GHz

Detector = Peak / Average

RBW= 1MHz

Plots reported here represent the worst case emissions for horizontal and vertical antenna polarizations and for three orientations of the EUT. Unless mentioned otherwise, the emissions outside the limit lines in the plots are from the transmit signal.

### 14.2 Limits: §15.247/15.205/15.209 & RSS-Gen 8.9/ 8.10 (restricted bands)

(a) Except as shown in paragraph (d) of this section, only spurious emissions are permitted in any of the frequency bands listed below:

MHz	MHz	MHz	GHz
0.090 - 0.110	16.42 - 16.423	399.9 - 410	4.5 - 5.15
<sup>1</sup> 0.495 - 0.505	16.69475 - 16.69525	608 - 614	5.35 - 5.46
2.1735 - 2.1905	16.80425 - 16.80475	960 - 1240	7.25 - 7.75
4.125 - 4.128	25.5 - 25.67	1300 - 1427	8.025 - 8.5
4.17725 - 4.17775	37.5 - 38.25	1435 - 1626.5	9.0 - 9.2
4.20725 - 4.20775	73 - 74.6	1645.5 - 1646.5	9.3 - 9.5
6.215 - 6.218	74.8 - 75.2	1660 - 1710	10.6 - 12.7
6.26775 - 6.26825	108 - 121.94	1718.8 - 1722.2	13.25 - 13.4
6.31175 - 6.31225	123 - 138	2200 - 2300	14.47 - 14.5
8.291 - 8.294	149.9 - 150.05	2310 - 2390	15.35 - 16.2
8.362 - 8.366	156.52475 - 156.52525	2483.5 - 2500	17.7 - 21.4
8.37625 - 8.38675	156.7 - 156.9	2690 - 2900	22.01 - 23.12
8.41425 - 8.41475	162.0125 - 167.17	3260 - 3267	23.6 - 24.0
12.29 - 12.293	167.72 - 173.2	3332 - 3339	31.2 - 31.8
12.51975 - 12.52025	240 - 285	3345.8 - 3358	36.43 - 36.5
12.57675 - 12.57725	322 - 335.4	3600 - 4400	( <sup>2</sup> )
13.36 - 13.41			

Radiated emissions which fall in the restricted bands, as defined in §15.205(a), must also comply with the radiated emission limits specified in §15.209(a) (see §15.205(c)).

\*PEAK LIMIT= 74dBµV/m



\*AVG. LIMIT= 54dB $\mu$ V/m

**Table 1:**

Frequency of emission (MHz)	Field strength @ 3m ( $\mu$ V/m)	Field strength @ 3m (dB $\mu$ V/m)
30–88	100	40dB $\mu$ V/m
88–216	150	43.5 dB $\mu$ V/m
216–960	200	46 dB $\mu$ V/m
Above 960	500	54 dB $\mu$ V/m

**Table 2:**

Frequency of emission (MHz)	Field strength ( $\mu$ V/m) / (dB $\mu$ V/m)	Measurement Distance (m)
0.009–0.490	2400/F(kHz) / -----	300
0.490–1.705	24000/F(kHz) / -----	30
1.705–30.0	30 / (29.5)	30

Radiated spurious emissions shall be measured for the transmit frequencies, transmit power, and data rate for the lowest, middle and highest channel in each frequency band of operation and for the highest gain antenna for each antenna type, and using the appropriate parameters and test requirements described in 5.4.

**The highest (or worst-case) data rate shall be recorded for each measurement.**

For testing at distance other than the specified in the standard, the limit conversion is calculated by using 40 dB/decade extrapolation factors as follow:

$$\text{Conversion factor (CF)} = 40 \log (D/d) = 40 \log (300\text{m} / 3\text{m}) = 80\text{dB}$$

14.3 Test conditions and setup:

Ambient Temperature	EUT Set-Up #	EUT operating mode	Power Input
23° C	1	Tx	Battery, 3.8V DC

14.4 Measurement result:

Plot #	Channel #	Scan Frequency	Limit	Result
1-3	1	30 MHz – 18 GHz	See section 8.7.2	Pass
4-8	7	9 kHz – 26 GHz	See section 8.7.2	Pass
9-12	11	30 MHz – 18 GHz	See section 8.7.2	Pass

14.5 Measurement Plots:

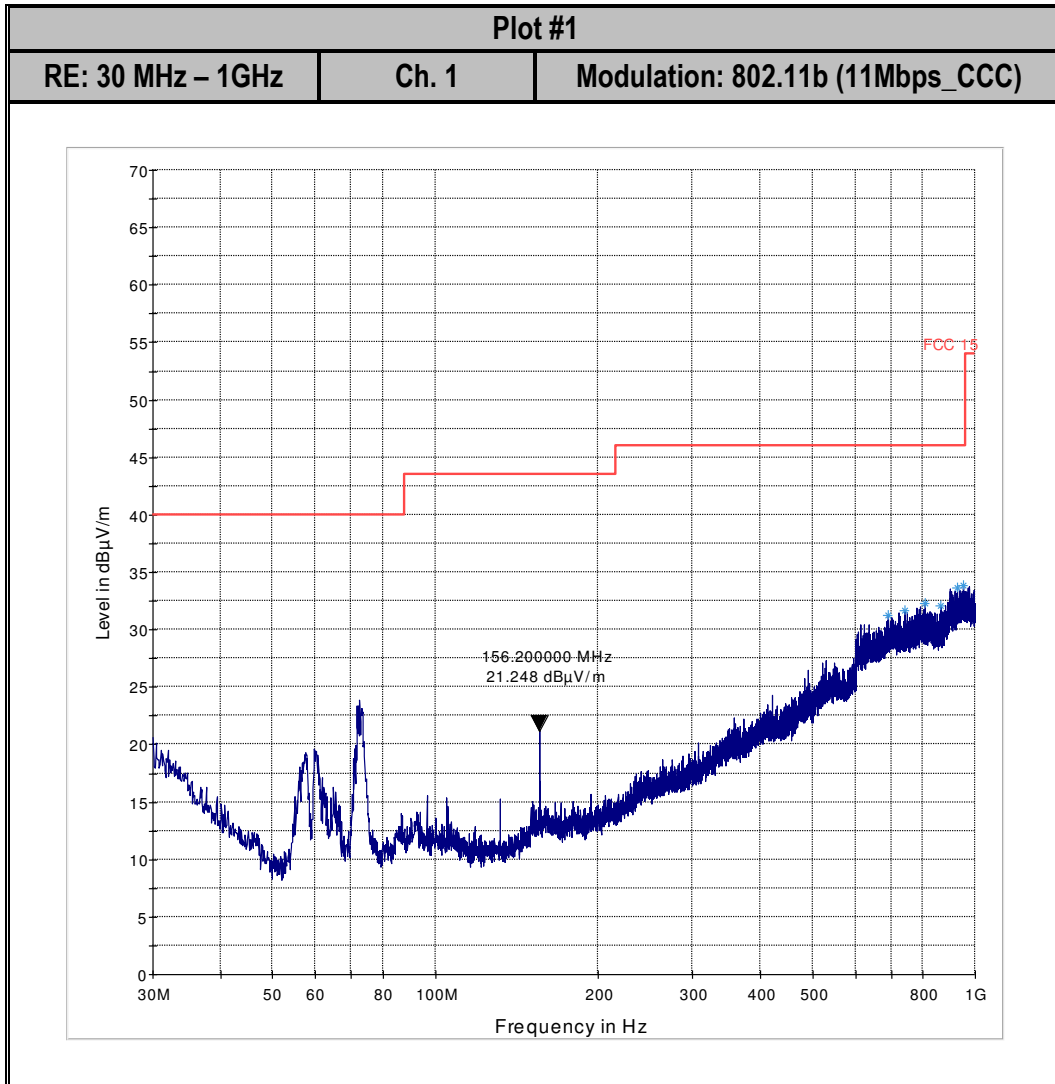

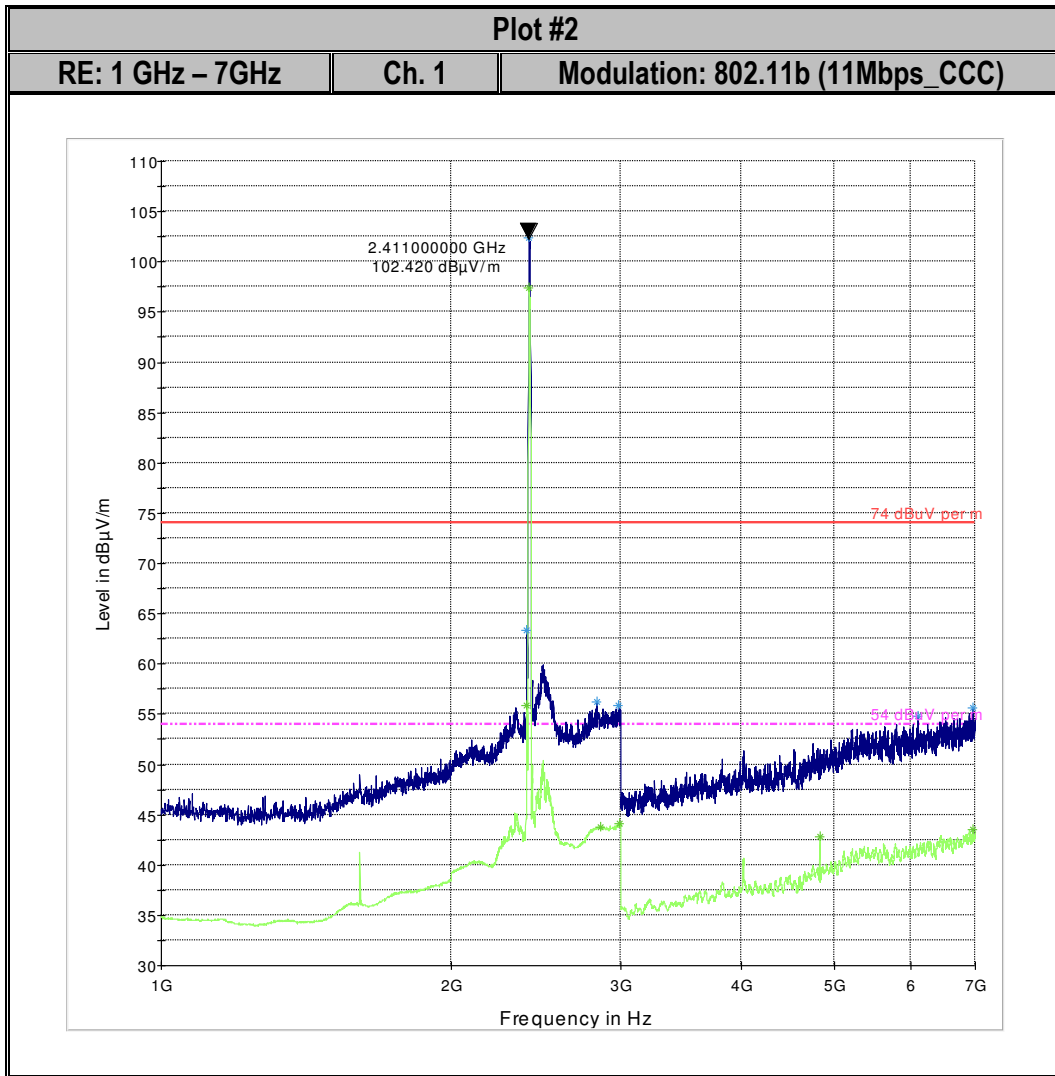

\*Note: The peak signal is the Tx channel low.

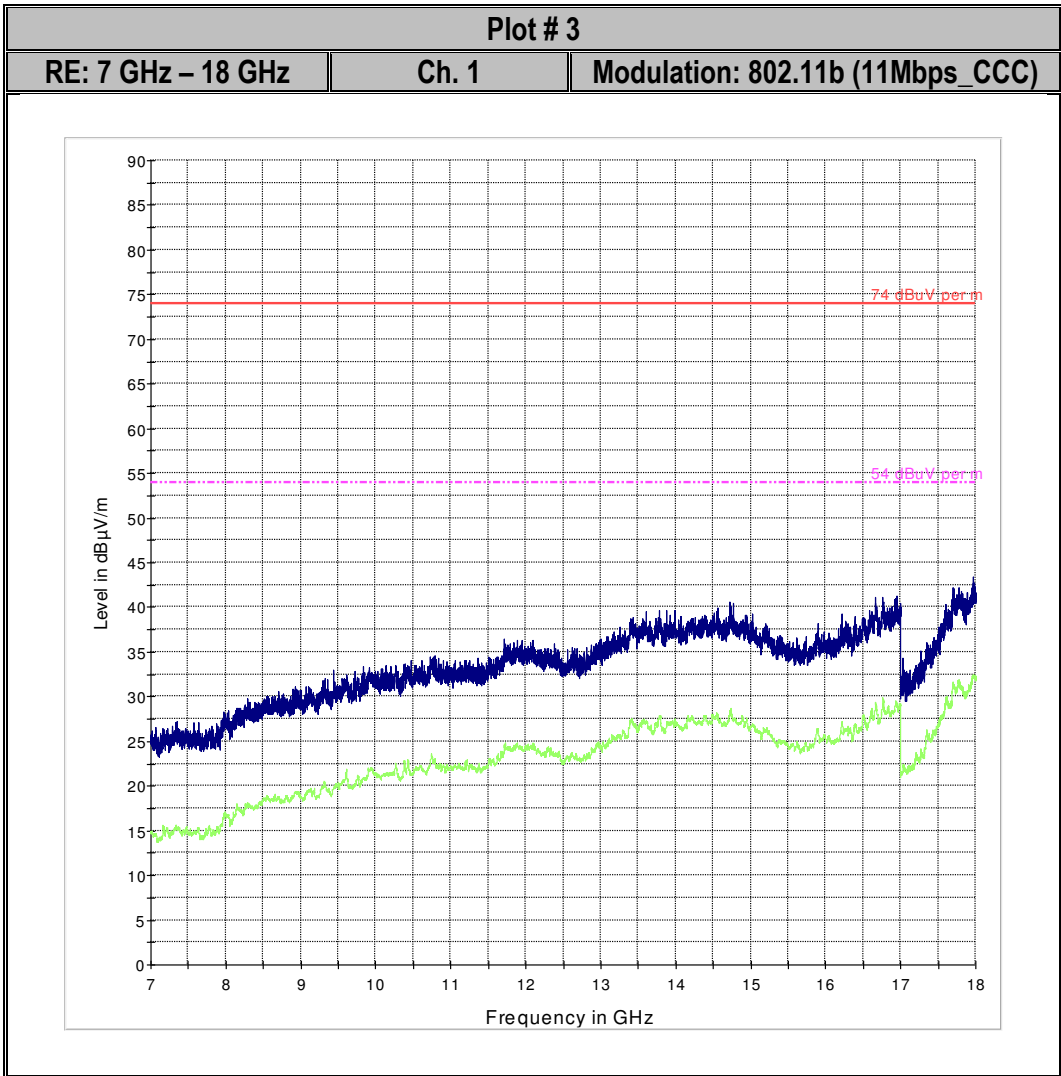

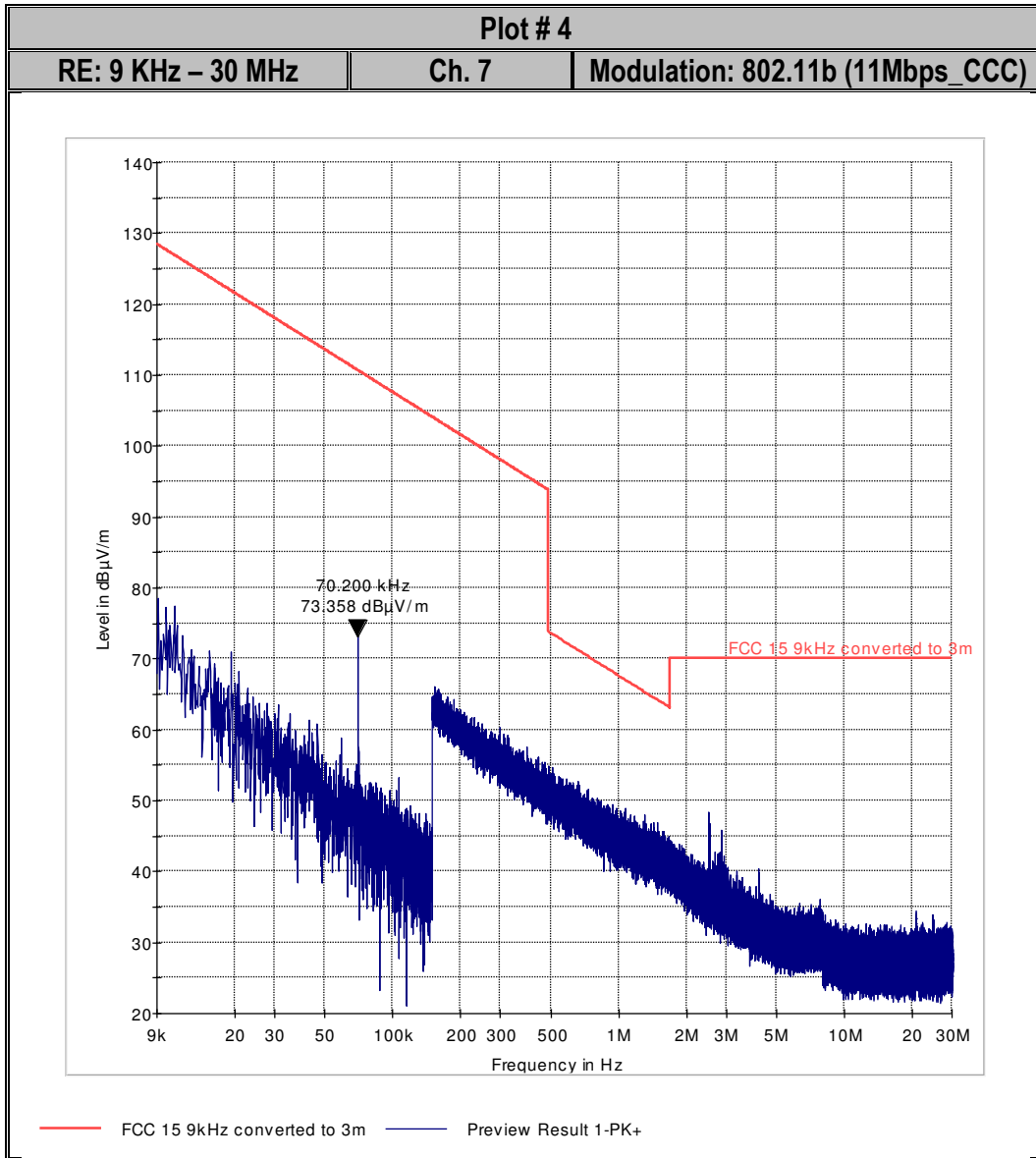

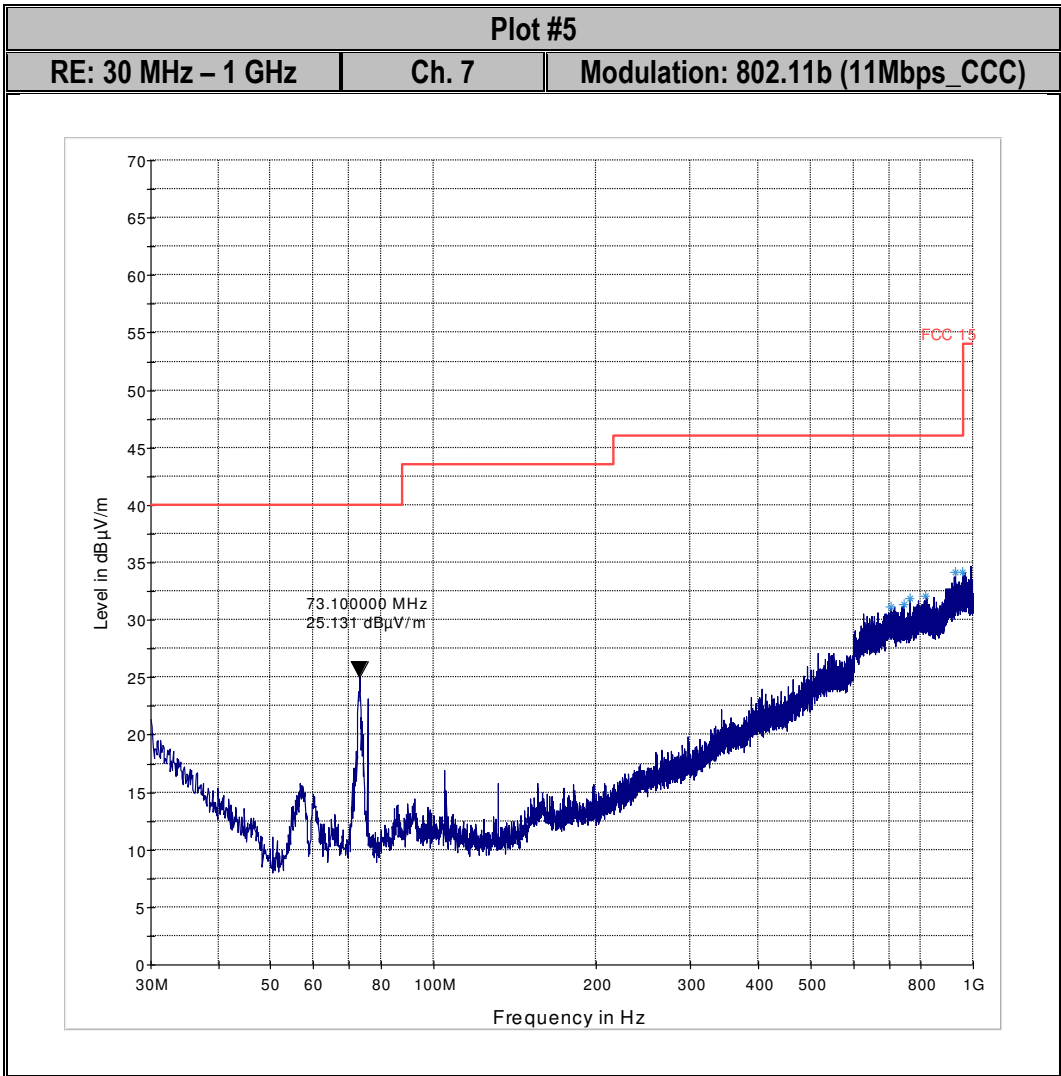

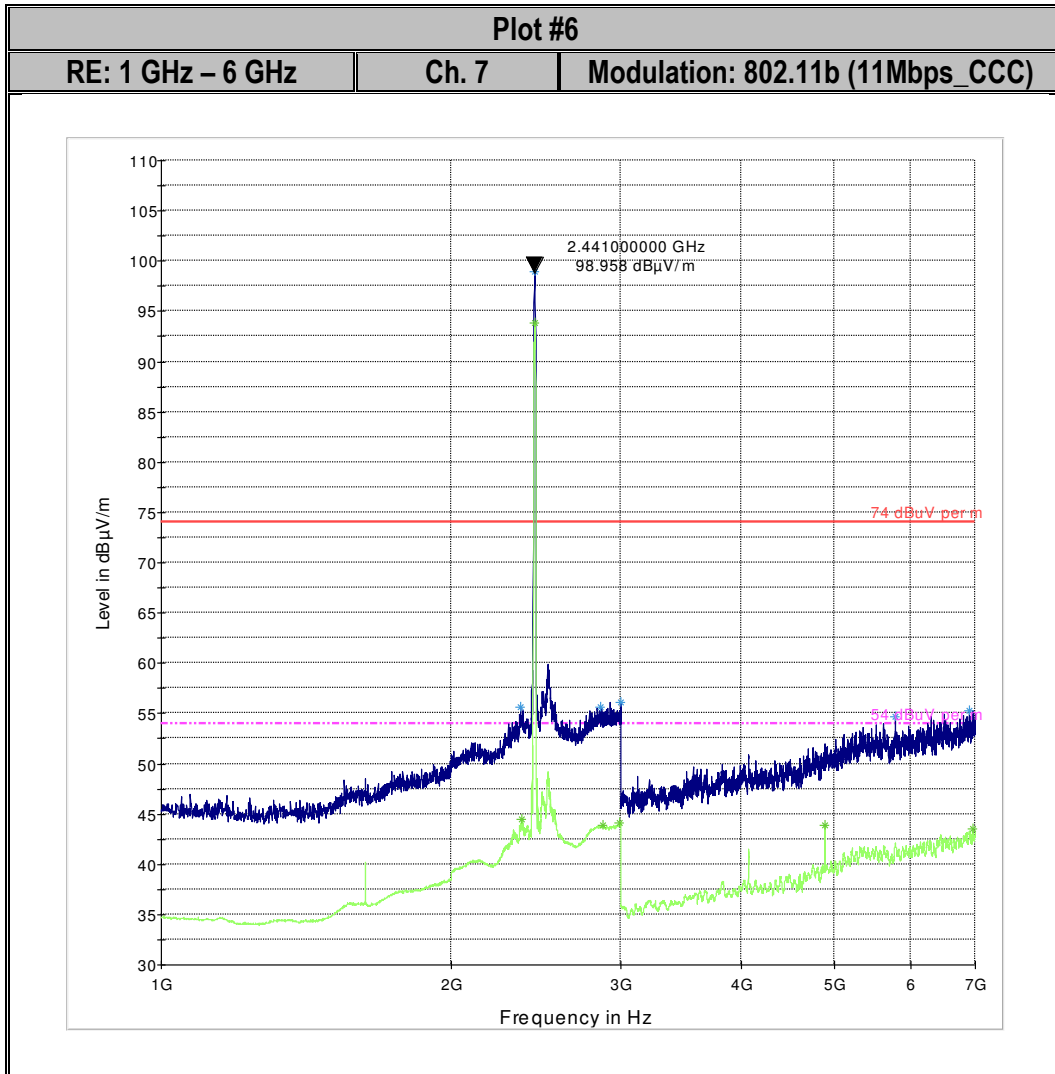

\*Note: The peak signal is the Tx Ch.7.

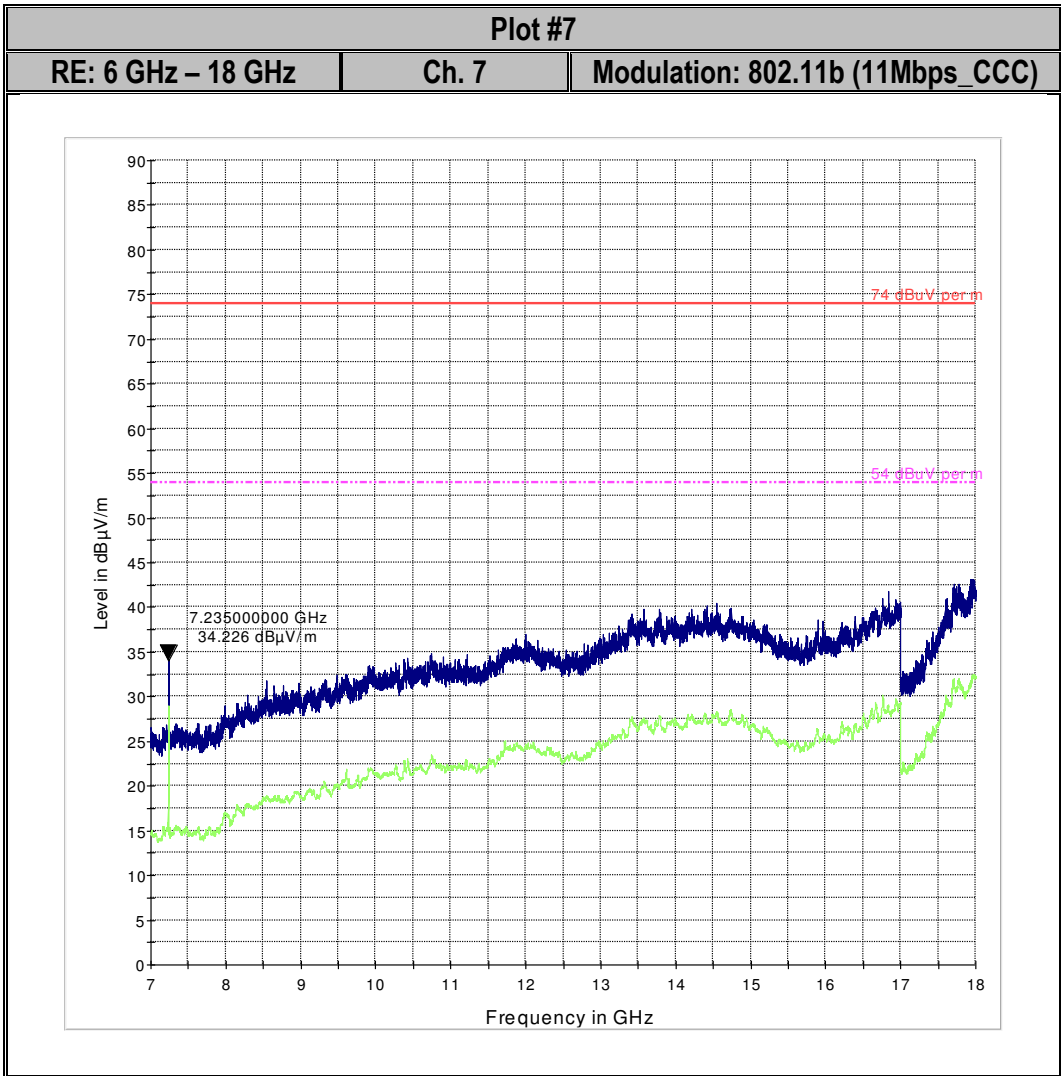



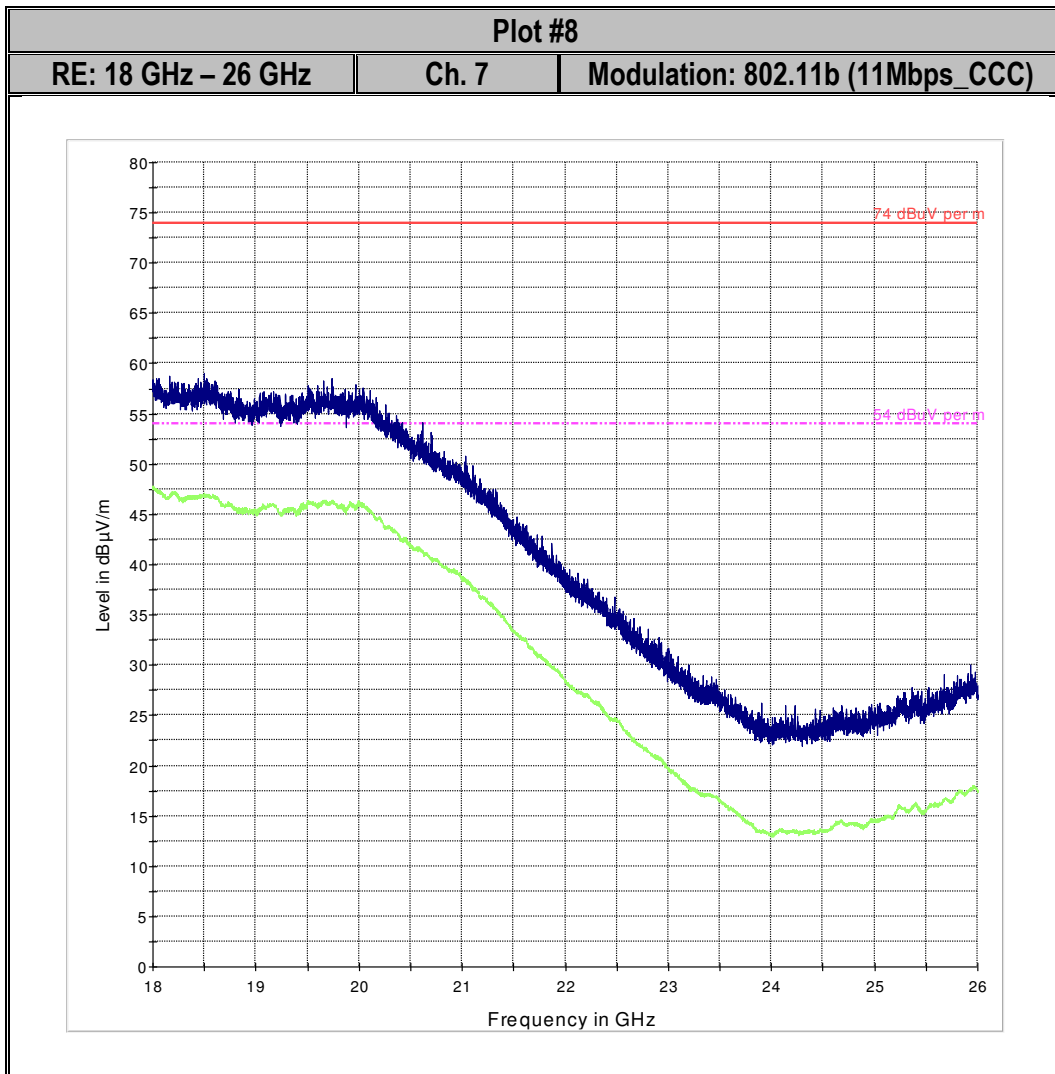

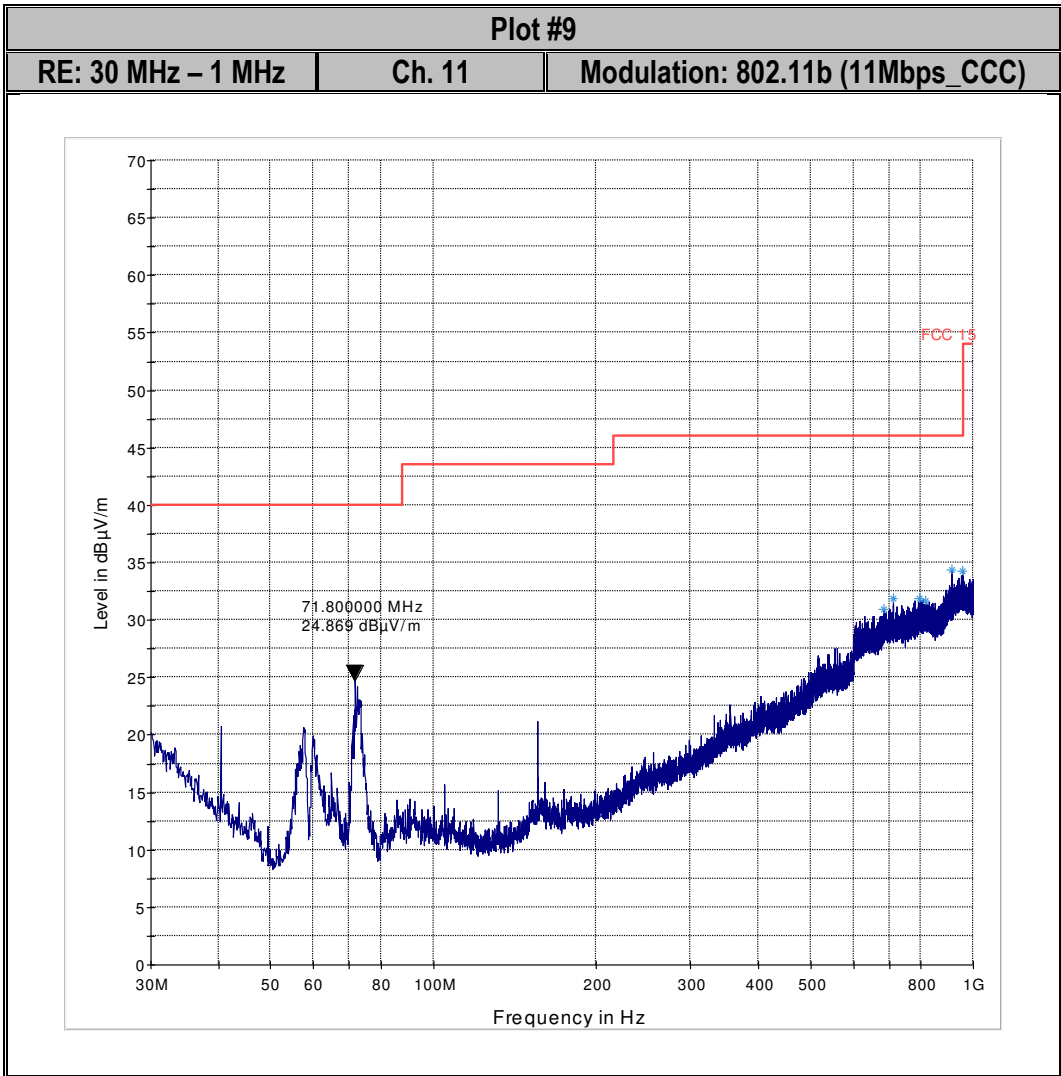

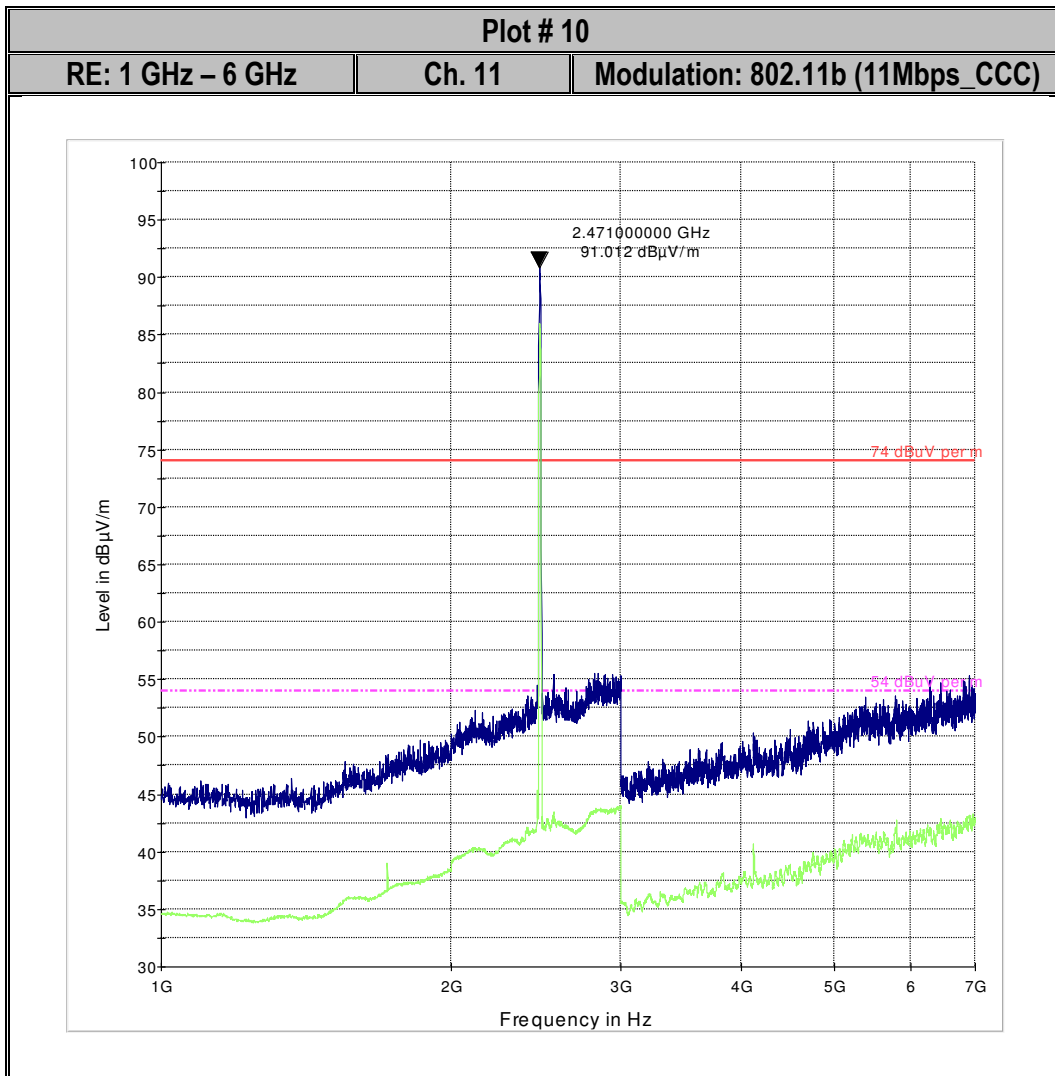

\*Note: The peak signal is the Tx Ch. 11.

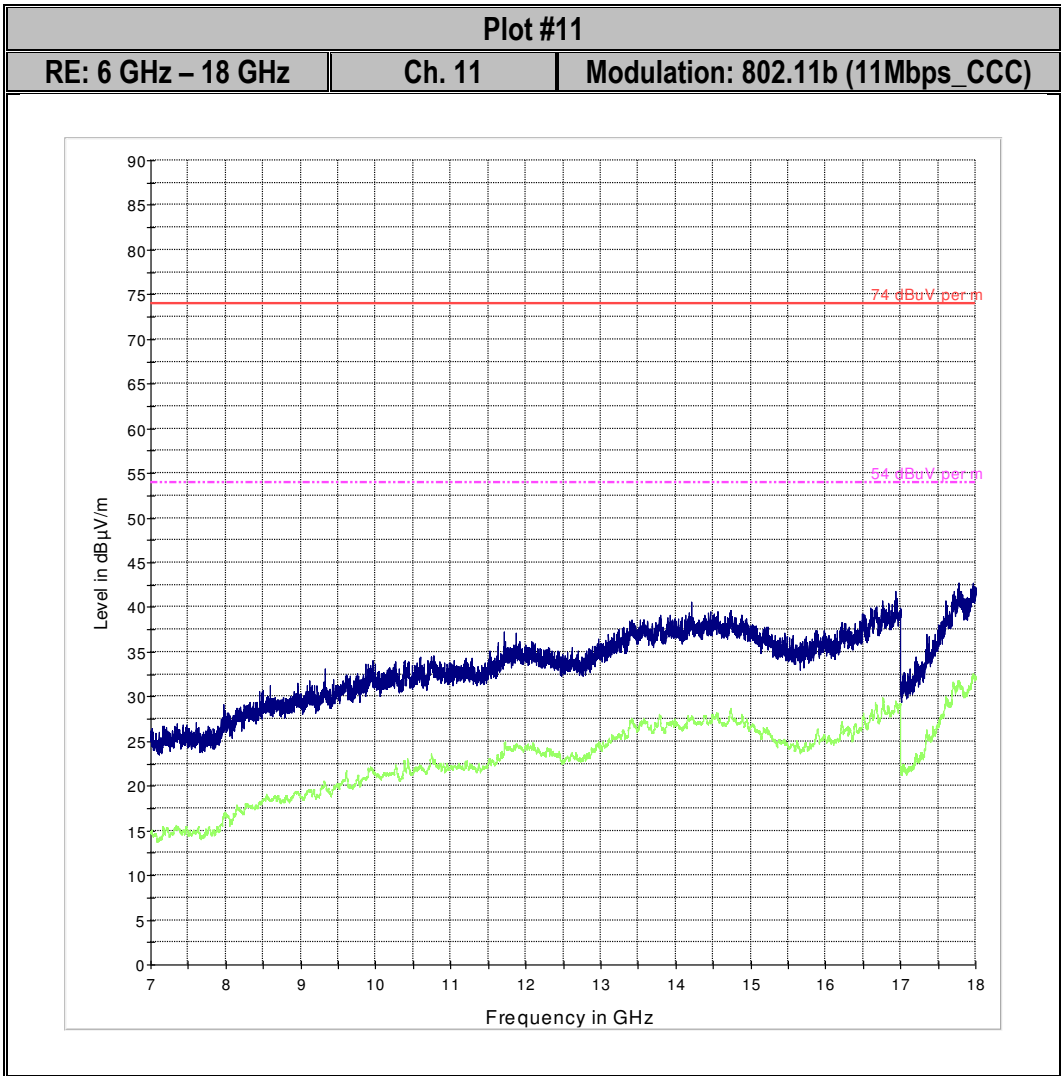

## 15 AC Power Line Conducted Emissions

The purpose of this test is to measure unwanted radio frequency currents induced in any AC conductor external to the equipment which could conduct interference to other equipment via the AC electrical network.

### 15.1 Limits:

§15.207 & RSS-Gen 8.8

(a) Except as shown in paragraphs (b) and (c) of this section of the CFR, for an intentional radiator that is designed to be connected to the public utility (AC) power line, the radio frequency voltage that is conducted back onto the AC power line on any frequency or frequencies, within the band 150 kHz to 30 MHz, shall not exceed the limits in the following table (1), as measured using a 50  $\mu$ H/50 ohms line impedance stabilization network (LISN). Compliance with the provisions of this paragraph shall be based on the measurement of the radio frequency voltage between each power line and ground at the power terminal. The lower limit applies at the boundary between the frequency ranges.

**Table 1:**

Frequency of emission (MHz)	Conducted limit (dB $\mu$ V)	
	Quasi-peak	Average
0.15–0.5	66 to 56*	56 to 46*
0.5–5	56	46
5–30	60	50

\*Decreases with the logarithm of the frequency.

### 15.2 Test conditions and setup:

Ambient Temperature	EUT Set-Up #	EUT operating mode	Power Input
23° C	3	Tx	AC/DC Power Supply

### 15.3 Test Procedure:

Measurement according to ANSI C63.10:2013 section 6.2 and 4.1 (also refer to section 6, 6.3 in this test report)

#### **Analyzer Settings:**

**RBW** = 9 KHz (CISPR Bandwidth)

**Detector:** Quasi-Peak / Average

Test Report #:	EMC_MOOGI-005-15001_15.247_WLAN	FCC ID: 2AGRZ-ILC3000	
Date of Report	January 27, 2015	Page 62 of 67	

15.4 Results:

Pass

15.5 Test Data:

**Conducted Emissions: 150 KHz – 30 MHz**

Frequency (MHz)	Quasi-Peak (dBuV)	Measurement Time (ms)	BW (KHz)	PE	Line	Corr. (dB)	Margin (dB)	Limit (dBuV)	Comments
0.602000	38.0	500.0	9.000	GND	N	0.4	18.0	56.0	
0.810000	36.9	500.0	9.000	GND	L1	0.4	19.1	56.0	
1.150000	40.0	500.0	9.000	GND	L1	0.4	16.0	56.0	
1.618000	40.7	500.0	9.000	GND	L1	0.5	15.3	56.0	
2.118000	46.2	500.0	9.000	GND	L1	0.5	9.5	56.0	
2.190000	48.1	500.0	9.000	GND	L1	0.5	7.9	56.0	

15.6 Measurement Plots:

**Conducted Emissions: 150 KHz – 30 MHz**

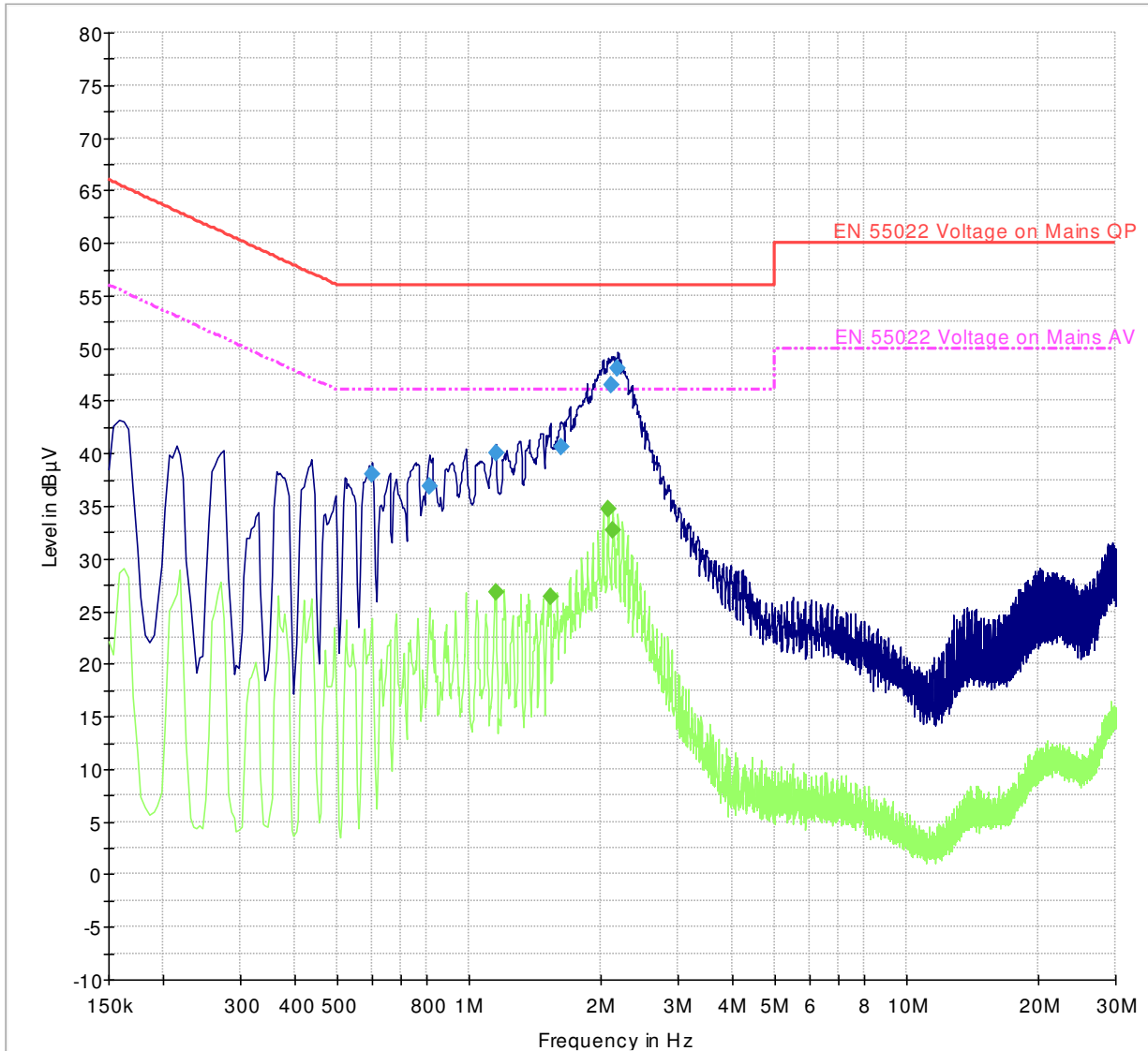

- |   |                              |         |                              |
|---|------------------------------|---------|------------------------------|
| — | EN 55022 Voltage on Mains QP | - - - - | EN 55022 Voltage on Mains AV |
| — | Preview Result 1-PK+         | —       | Preview Result 2-AVG         |
| ◆ | Final Result 1-QPK           | ◆       | Final Result 2-AVG           |

**Note:** Plots shown here represent the combined worse case emissions for power lines (phases and neutral line).

Test Report #:	EMC_MOOGI-005-15001_15.247_WLAN	FCC ID: 2AGRZ-ILC3000	
Date of Report	January 27, 2015	Page 64 of 67	

## 16 Setup Pictures

Please refer to EMC\_MOOGI-005-15001\_TestSetupPhotos.pdf



Test Report #:	EMC_MOOGI-005-15001_15.247_WLAN	FCC ID: 2AGRZ-ILC3000	
Date of Report	January 27, 2015	Page 65 of 67	

## 17 EUT pictures

Please refer to EMC\_MOOGI-005-15001\_TestSetupPhotos.pdf

Test Report #:	EMC_MOOGI-005-15001_15.247_WLAN	FCC ID: 2AGRZ-ILC3000	
Date of Report	January 27, 2015	Page 66 of 67	

## 18 Test Equipment and Ancillaries Used For Testing

Item Name	Equipment Type	Manufacturer	Model	Serial #	Calibration Cycle	Last Calibration Date
Antenna Biconilog 3142E	Biconilog Antenna	EMCO	3142E	166067	3 years	6/14/2014
Antenna Biconilog 3149	Biconilog Antenna	EMCO	3149	63983	3 years	4/9/2014
Antenna Horn 3115 SN 35111	Horn Antenna	EMCO	3115	35111	3 years	7/24/2015
Antenna Horn 3116	Horn Antenna	ETS Lindgren	3116	70497	3 years	7/22/2015
Antenna Loop 6512	Loop Antenna	ETS Lindgren	6512	49838	3 years	3/13/2014
Audio Analyzer UPL16	Audio Analyzer	R&S	UPL16	838205/0005	3 years	5/25/2013
Bluetooth Comm. Tester CBT	Bluetooth Comm. Tester	R&S	CBT	100212	3 years	7/1/2015
CMW500	CMW 500	R&S	WIDEB. RADIO COMM. TESTER	127068	3 years	3/12/2015
Current Probe EZ-17 Immunity	RF Current Probe Conducted Emissions	R&S	EZ-17	834613/007	3 years	6/17/2013
Digital Barometer	Compact Digital Barometer	Control Company	35519-055	91119547	2 Years	4/7/2015
Digital Radio Comm. Tester CMU 200 #1	Digital Radio Comm. Tester	R&S	CMU 200 #1	101821	2 Years	7/4/2015
ESD Gun NSG 437	ESD Gun	Teseq Inc.	NSG 437	221	2 Years	2/14/2014
Immunity Tester Generator UCS 500 M4	Immunity Tester Generator	Amplifier Research	UCS 500 M4	28256	2 Years	4/15/2014
Oscilloscope	Oscilloscope	R&S	RTO 1014	300087	3 years	7/24/2013
Power Meter NRVD	Power Meter	R&S	NRVD	836875/020	3 years	6/15/2013
Power Sensor Insertion URV5-Z2 SN 100727	Power Sensor / 10V Insertion	R&S	URV5-Z2	100727	3 years	6/15/2013
Power Sensor Insertion URV5-Z2 SN 836029	Power Sensor 10V Insertion	R&S	URV5-Z2	836029/035	3 years	6/15/2013
Power Sensor NRP - Z22	Power Sensor	R&S	NRP-Z22	100223	3 years	6/17/2013
Power Sensor NRP - Z81	Power Smart Sensor	R&S	NRP-Z81	100161	3 years	6/15/2013
Radiated Immunity Probe HI6005	Radiated Immunity Probe	ETS Lindgren	HI6005	105107	2 Years	3/21/2014
Receiver ESU40	EMI Receiver	R&S	ESU40	100251	3 years	6/29/2015
Signal Generator SME03	Signal Generator	Amplifier Research	SME 03	1038-6002-03	3 years	6/13/2013
Signal Generator SMP04	Signal Generator	R&S	SMP04	100151	3 years	6/17/2013
Spectrum Analyzer FSU08	Spectrum Analyzer	R&S	FSU-8	200256	2 Years	7/5/2015
Spectrum Analyzer FSU26 #1	FSU 26	Amplifier Research	FSU 26	100189	3 years	6/1/2013
Spectrum Analyzer FSU26 #2	Spectrum Analyzer	R&S	FSU26	200065	3 years	7/4/2015

Equipment used meets the measurement uncertainty requirements as required per applicable standards for 95% confidence levels.

Calibration due dates, unless defined specifically, falls on the last day of the month.

Items indicated "N/A" for cal status either do not specifically require calibration or is internally characterized before use.

Test Report #:	EMC_MOOGI-005-15001_15.247_WLAN	FCC ID: 2AGRZ-ILC3000	
Date of Report	January 27, 2015	Page 67 of 67	

## 19 Revision History

Date	Report Name	Changes to report	Report prepared by
January 27, 2015	EMC_MOOGI-005-15001_15.247_WLAN	Initial Version	Franz Engert