

Zykronix Inc. Taiwan Branch

TEST REPORT

REPORT NUMBER
200900146TWN-001

ISSUE DATE
Nov. 11, 2020

PAGES
32

© 2020 INTERTEK



FCC Class II Chang TEST REPORT

Applicant:	Zykronix Inc. Taiwan Branch 14F. -8, No. 3, Sec. 4, New Taipei Blvd., Xinzhuang Dist., New Taipei City, Taiwan
Product:	W-LAN + Bluetooth Module
Model No.:	LBEE5ZZ1PJ
Brand Name:	N/A
FCC ID:	2AGRR-LBEE5ZZ1PJ
Test Method/ Standard:	47 CFR FCC Part 15.247 & ANSI C63.10 2013 KDB 558074 D01 v05r02
Test By:	Intertek Testing Services Taiwan Ltd., Hsinchu Laboratory No. 11, Lane 275, Ko-Nan 1 Street, Chia-Tung Li, Shiang-Shan District, Hsinchu City, Taiwan



Prepared and Checked by:

Zero chen

Zero Chen
Engineer

Approved by:

Durant Wei

Durant Wei
Engineer

This report is for the exclusive use of Intertek's Client and is provided pursuant to the agreement between Intertek and its Client. Intertek's responsibility and liability are limited to the terms and conditions of the agreement. Intertek assumes no liability to any party, other than to the Client in accordance with the agreement, for any loss, expense or damage occasioned by the use of this report. Only the Client is authorized to permit copying or distribution of this report and then only in its entirety. Any use of the Intertek name or one of its marks for the sale or advertisement of the tested material, product or service must first be approved in writing by Intertek. The observations and test results in this report are relevant only to the sample tested. This report by itself does not imply that the material, product, or service is or has ever been under an Intertek certification program.

Revision History

Report No.	Issue Date	Revision Summary
200900146TWN-001	Nov. 11, 2020	Original report (This case is to add hosts.)

TEST REPORT**Table of Contents**

1. General Information	5
1.1 Identification of the EUT	5
1.2 Additional information about the Hosts	5
1.3 Antenna description	6
1.4 Operation mode	6
1.5 Peripherals equipment	6
2. Maximum Peak Conducted Output Power	7
2.1 Instrument Setting.....	7
2.2 Test Procedure	7
2.3 Test Diagram	7
2.4 Limit	7
2.5 Operating Environment Condition	7
2.6 Test Results	8
3. Emissions in Restricted Frequency Bands (Radiated emission measurements)	9
3.1 Instrument Setting.....	9
3.2 Test Procedure	9
3.3 Test Diagram	10
3.3.1 Radiated emission from 9kHz to 30MHz uses Loop Antenna:	10
3.3.2 Radiated emission below 1GHz using Bilog Antenna	10
3.3.3 Radiated emission above 1GHz using Horn Antenna	11
3.4 Limit	11
3.5 Operating Environment Condition	11
3.6 Test Result.....	12
4. Emission on Band Edge.....	19
4.1 Instrument Setting.....	19
4.2 Test Procedure	19
4.3 Operating Environment Condition	19
4.4 Test Results	20
5. AC Power Line Conducted Emission	27
5.1 Measuring instrument setting.....	27
5.2 Test Procedure	27
5.3 Test Diagram	27
5.4 Limit	28
5.5 Operating Environment Condition	28
5.6 Test Results	29
Appendix A: Test equipment list.....	31
Appendix B: Measurement Uncertainty.....	32

Summary of Test Data

Test Requirement	Applicable Rule (Section 15.247)	Result
Maximum Peak Conducted Output Power	15.247(b)(3)	Pass
Emissions In Restricted Frequency Bands (Radiated emission measurements)	15.247(d), 15.205, 15.209	Pass
Emission On The Band Edge	15.247(d), 15.205	Pass
AC Power Line Conducted Emission	15.207	Pass
Antenna Requirement	15.203	Pass

Note: Please note that the test results with statement of conformity, the decision rules which are based on: Safety Testing: the specification, standard or IEC Guide 115.

Other Testing: the specification, standard and not taking into account the measurement uncertainty.

1. General Information

1.1 Identification of the EUT

Product:	15.6" Touch Screen Controller
Model No.:	Milano XL
Operating Frequency:	2412 MHz ~ 2462 MHz for 802.11b, 802.11g, 802.11n HT20 2422 MHz ~ 2452 MHz for 802.11n HT40
Channel Number:	11 channels for 2412 MHz ~ 2462 MHz 7 channels for 2422 MHz ~ 2452 MHz
Frequency of Each Channel:	2412+5 k, k=0 ~ 10 for 802.11b, 802.11g, 802.11n HT20 2422+5 k, k=0 ~ 6 for 802.11n HT40
Access scheme:	DSSS, OFDM
Rated Power:	DC 24 V from adapter
Power Cord:	N/A
Sample receiving date:	Sep. 14, 2020
Sample condition:	Workable
Test Date(s):	Oct. 06, 2020 ~ Oct. 20, 2020

1.2 Additional information about the Hosts

Brand Name	Model Name	Model Number	Different
Zykronix	15.6" Touch Screen Controller	Milano XL	The Model is main model
Zykronix	11.6" Touch Screen Controller	Symphony XL	The difference from the main model is the screen size
Zykronix	11.6" Touch Screen Controller	Symphony II	The difference from the main model is the screen size & has no LED
Zykronix	8.0" Touch Screen Controller	Melody XL	The difference from the main model is the screen size
Zykronix	8.0" Touch Screen Controller	Melody II	The difference from the main model is the screen size & has no LED
Zykronix	6.0" Touch Screen Controller	Giulia	The difference from the main model is the screen size & has no LED

1.3 Antenna description

Antenna Gain : 2.15 dBi
 Antenna Type : FPC antenna
 Connector Type : I-Pex

1.4 Operation mode

The EUT was supplied with DC 24 V from adapter (Test voltage: 120Vac, 60Hz).
 EUT connected to Notebook PC & Wireless AP via Micro USB Cable & LAN, executing
 “Qualcomm Radio Control Tool” and select different frequency and modulation.

With individual verifying, the maximum output power were found out 1 Mbps data rate for 802.11b mode, 6 Mbps data rate for 802.11g mode, 6.5 Mbps data rate for 802.11n(HT20) mode, 13.5 Mbps data rate for 802.11n(HT40) mode the final tests were executed under these conditions recorded in this report individually.

Modulation mode	Transmit path
	Chain 0 / Main
802.11b	V
802.11g	V
802.11 n (HT20)	V
802.11 n (HT40)	V

1.5 Peripherals equipment

Peripherals	Brand	Model No.	Serial No.	Data cable
Notebook PC	HP	HP ProBook 440 G3	5CD8021S9H	Micro USB Cable 0.8 meter × 1
Wireless AP	BUFFALO	WZR-AGL300NH	N/A	RJ-45 STP Cat.5 0.8 meter × 2
Adapter	N/A	ADP-85NB A	N/A	N/A

2. Maximum Peak Conducted Output Power

2.1 Instrument Setting

Power Meter Parameter	Setting
Bandwidth	65MHz bandwidth is greater than the EUT emission bandwidth
Detector	Peak & Average

2.2 Test Procedure

The preferred methodology is to use integrated average power measurements, as described in 11.9.2 and 11.13.3 of ANSI C63.10. The peak integrated band power methods of 11.9.1.2 and 11.13.3.2 of ANSI C63.10 are not applicable for FCC compliance testing purposes.

2.3 Test Diagram

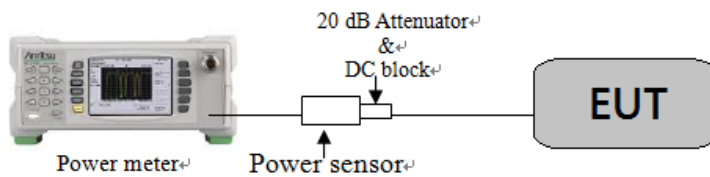

2.4 Limit

For systems using digital modulation in the 2400-2483.5 MHz: 1 Watt (30dBm)

2.5 Operating Environment Condition

Temperature (°C) :	26
Relative Humidity (%) :	57

2.6 Test Results

Mode	Channel	Frequency (MHz)	Data Rate (Mbps)	Output Power (AV) (dBm)	Total Power (AV) (mW)	Maximum power (PK) (dBm)	Maximum power (PK) (mW)	Limit (dBm)	Margin (dB)
802.11b	1	2412	1	18.69	73.96	21.13	129.72	30	-8.87
	6	2437		18.33	68.08	21.08	128.23	30	-8.92
	11	2462		17.99	62.95	20.45	110.92	30	-9.55
802.11g	1	2412	6	17.59	57.41	25.08	322.11	30	-4.92
	6	2437		17.42	55.21	24.88	307.61	30	-5.12
	11	2462		16.93	49.32	24.38	274.16	30	-5.62
802.11n (HT20)	1	2412	6.5	16.95	49.55	24.48	280.54	30	-5.52
	6	2437		16.72	46.99	24.17	261.22	30	-5.83
	11	2462		16.54	45.08	24.82	303.39	30	-5.18
802.11n (HT40)	3	2422	13.5	13.13	20.56	23.15	206.54	30	-6.85
	6	2437		13.01	20.00	23.06	202.30	30	-6.94
	9	2452		11.83	15.24	22.08	161.44	30	-7.92

3. Emissions in Restricted Frequency Bands (Radiated emission measurements)

3.1 Instrument Setting

Receiver Function	Setting (Below 1GHz)	Setting (Above 1GHz)
Detector	QP	Peak and Average
RBW	9-150 kHz ; 200-300 Hz 0.15-30 MHz; 9-10 kHz 30-1000 MHz; 100-120 kHz	1MHz
VBW	$\geq 3 \times \text{RBW}$	3MHz
Sweep	Auto couple	Auto couple
Start Frequency	9 kHz	1GHz
Stop Frequency	1 GHz	Tenth harmonic
Attenuation	Auto	Auto

3.2 Test Procedure

Step 1	Configure the EUT according to ANSI C63.10:2013. The EUT was placed on the top of the turntable 0.8 meter (below 1GHz) and 1.5 meter (above 1GHz) above ground. The center of the receiving antenna mounted on the top of a height-variable antenna tower was placed 3 meters far away from the turntable.
Step 2	Power on the EUT and all the companion devices. The turntable was rotated by 360 degree to find the position of the maximum emission level.
Step 3	The height of the receiving antenna was varied between one meter and four meters above ground to find the maximum emission field strength of the both horizontal and vertical polarization.
Step 4	If find the frequencies above the limit or below within 3dB, the antenna tower was scan (from 1m to 4m) and then the turntable was rotated to find the maximum reading.
Step 5	Set the test-receiver system to peak or CISPR quasi-peak detector with specified bandwidth under maximum hold mode.
Step 6	For emissions above 1GHz, use 1MHz VBW and 3MHz RBW for reading in spectrum analyzer. Place the measurement antenna away from each area of the EUT determined to be a source of emissions at the specified measurement distance, while keeping the measurement antenna aimed at the source of emissions at each frequency of significant emissions, with polarization oriented for maximum response.
Step 7	If the emissions level of the EUT in peak mode was 3dB lower than the average limit specified then testing will be stopped and peak values of the EUT will be reported. Otherwise, the emissions which do not have 3dB margin will be measured using the quasi-peak method for below 1GHz.
Step 8	For testing above 1GHz, The emissions level of the EUT in peak mode was lower than average limit, then testing will be stopped and peak values of the EUT will be reported, otherwise, the emission will be measured in average mode again and reported.

TEST REPORT

Step 9	In case the emission is lower than 30MHz, loop antenna has to be used for measurement and the recorded data should be quasi-peak measured by receiver.
--------	--

3.3 Test Diagram

3.3.1 Radiated emission from 9kHz to 30MHz uses Loop Antenna:

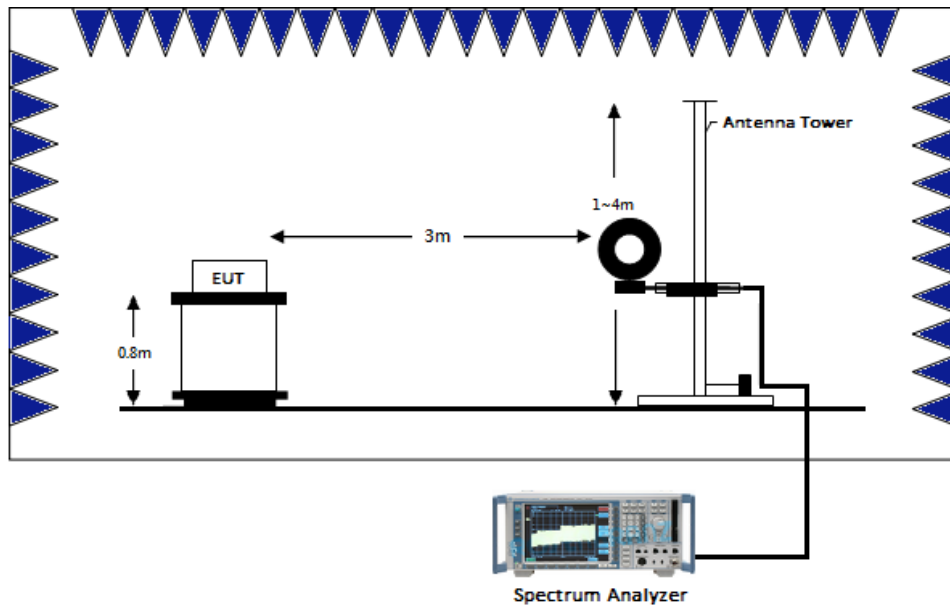

3.3.2 Radiated emission below 1GHz using Bilog Antenna

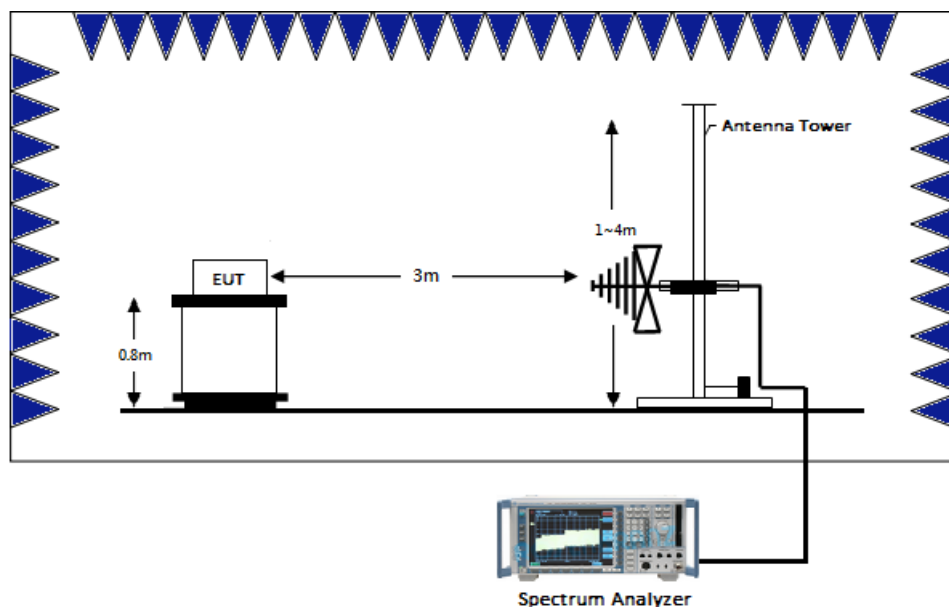

3.3.3 Radiated emission above 1GHz using Horn Antenna

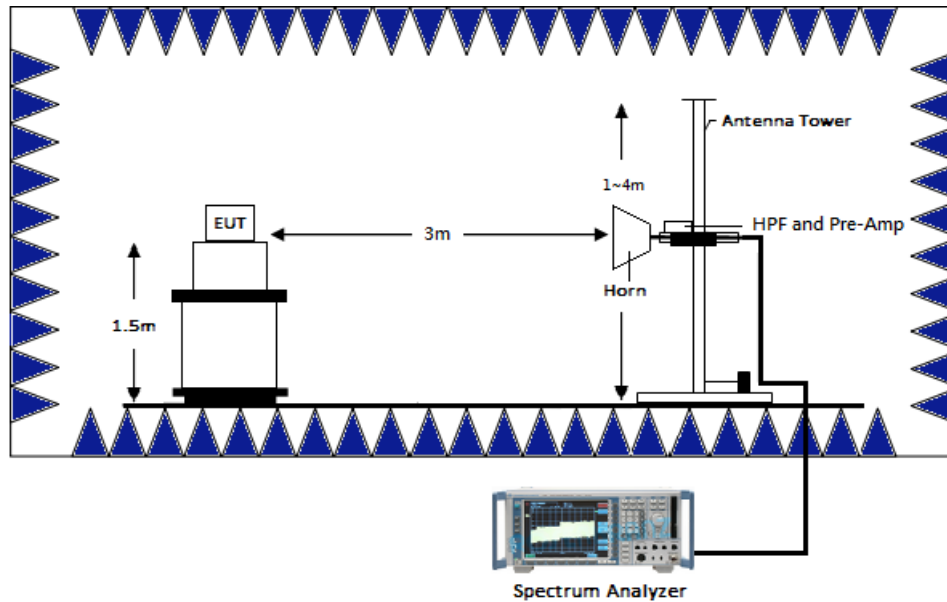

3.4 Limit

Frequency(MHz)	Field Strength(uV/m)	Measurement distance(m)
0.009~0.490	2400/F(kHz)	300
0.490~1.705	24000/F(kHz)	30
1.705~30	30	30
30-88	100	3
88-216	150	3
216-960	200	3
Above 960	500	3

Remark:

1. In the above table, the tighter limit applies at the band edges.
2. Distance refers to the distance in meters between the measuring instrument antenna and the closed point of any part of the device or system

3.5 Operating Environment Condition

Temperature (°C) :	25
Relative Humidity (%) :	56

3.6 Test Result

3.6.1 Measurement results: frequencies 9kHz to 30MHz

The test was performed on EUT under 802.11b/g/n continuously transmitting mode. The worst case occurred at 802.11g Channel 1.

Ant Polarity	Frequency (MHz)	Detector	Factor (dB/m)	Reading (dBμV)	Corrected Reading (dBμV/m)	Limit @ 3m (dBμV/m)	Margin (dB)
Perpendicular	0.01	AV	18.28	39.78	58.06	127.60	-69.54
Perpendicular	0.19	AV	18.13	32.56	50.69	102.03	-51.34
Perpendicular	0.37	AV	18.49	20.17	38.66	96.24	-57.58
Perpendicular	0.61	QP	18.44	15.57	34.01	71.90	-37.89
Perpendicular	0.79	QP	18.45	10.07	28.52	69.65	-41.13
Perpendicular	26.16	QP	21.25	1.85	23.10	69.54	-46.44

Remark: Corr. Factor = Antenna Factor + Cable Loss

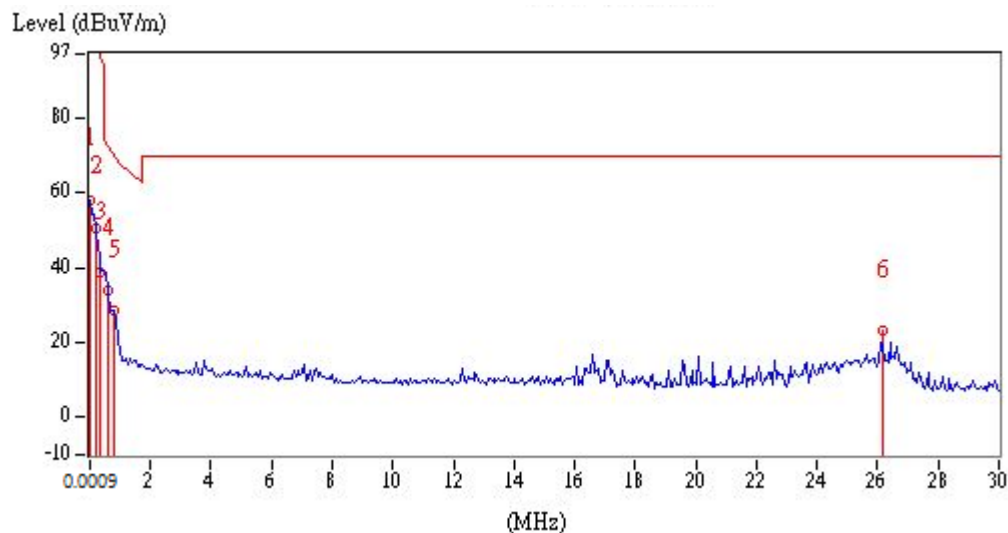

TEST REPORT

Ant Polarity	Frequency (MHz)	Detector	Factor (dB/m)	Reading (dB μ V)	Corrected Reading (dB μ V/m)	Limit @ 3m (dB μ V/m)	Margin (dB)
Parallel	0.07	AV	18.36	35.58	53.94	110.70	-56.76
Parallel	0.19	AV	18.13	32.87	51.00	102.03	-51.03
Parallel	0.31	AV	18.52	25.27	43.79	97.78	-53.99
Parallel	0.43	AV	18.46	21.42	39.88	94.93	-55.05
Parallel	0.61	QP	18.44	15.38	33.82	71.90	-38.08
Parallel	0.79	QP	18.45	9.52	27.97	69.65	-41.68

Remark: Corr. Factor = Antenna Factor + Cable Loss

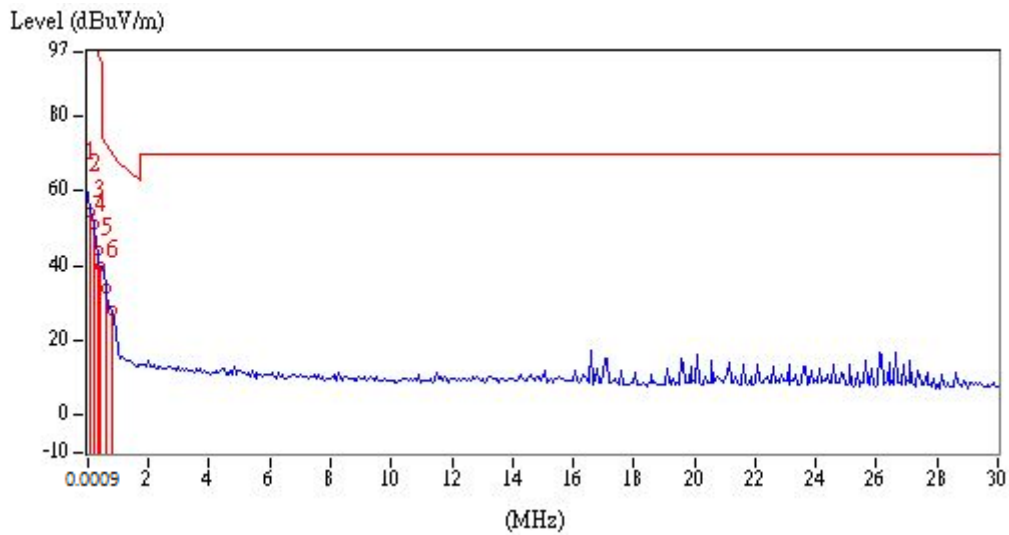

Ant Polarity	Frequency (MHz)	Detector	Factor (dB/m)	Reading (dB μ V)	Corrected Reading (dB μ V/m)	Limit @ 3m (dB μ V/m)	Margin (dB)
Ground-parallel	0.07	AV	18.36	36.06	54.42	110.70	-56.28
Ground-parallel	0.13	AV	17.91	36.01	53.92	105.33	-51.41
Ground-parallel	0.19	AV	18.13	32.49	50.62	102.03	-51.41
Ground-parallel	0.25	AV	18.34	27.03	45.37	99.65	-54.28
Ground-parallel	0.31	AV	18.52	24.76	43.28	97.78	-54.50
Ground-parallel	0.49	AV	18.44	21.28	39.72	93.80	-54.08

Remark: Corr. Factor = Antenna Factor + Cable Loss

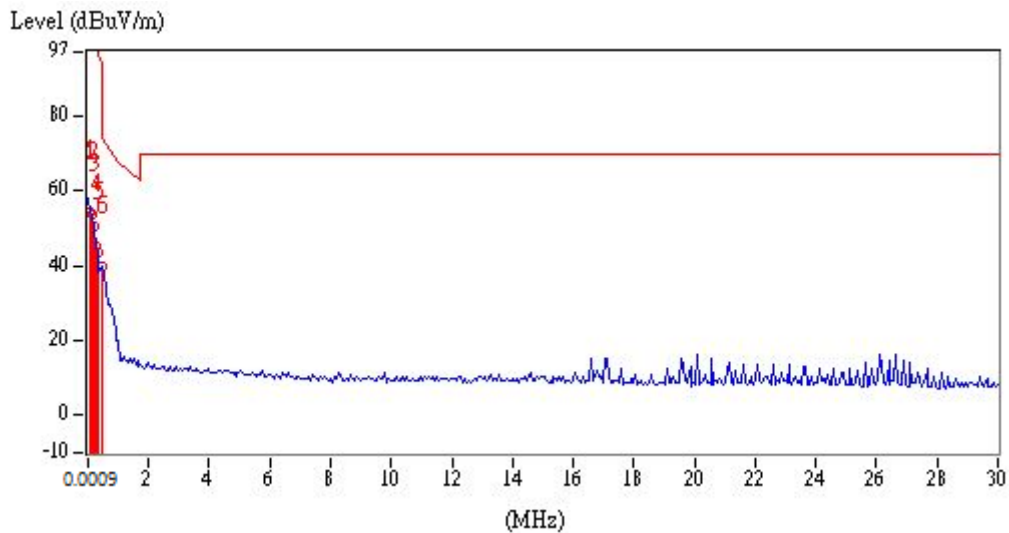

TEST REPORT

3.6.2 Measurement results: frequencies below 1 GHz

The test was performed on EUT under 802.11b/g/n continuously transmitting mode. The worst case occurred at 802.11g Channel 1.

Ant Polarity	Frequency (MHz)	Detector	Factor (dB/m)	Reading (dB μ V)	Corrected Reading (dB μ V/m)	Limit @ 3m (dB μ V/m)	Margin (dB)
Vertical	33.88	QP	20.76	13.52	34.28	40.00	-5.72
Vertical	47.46	QP	21.95	7.04	28.99	40.00	-11.01
Vertical	70.74	QP	19.46	12.66	32.12	40.00	-7.88
Vertical	123.12	QP	19.71	5.11	24.82	43.50	-18.68
Vertical	163.86	QP	21.79	6.74	28.53	43.50	-14.97
Vertical	171.62	QP	21.33	6.45	27.78	43.50	-15.72

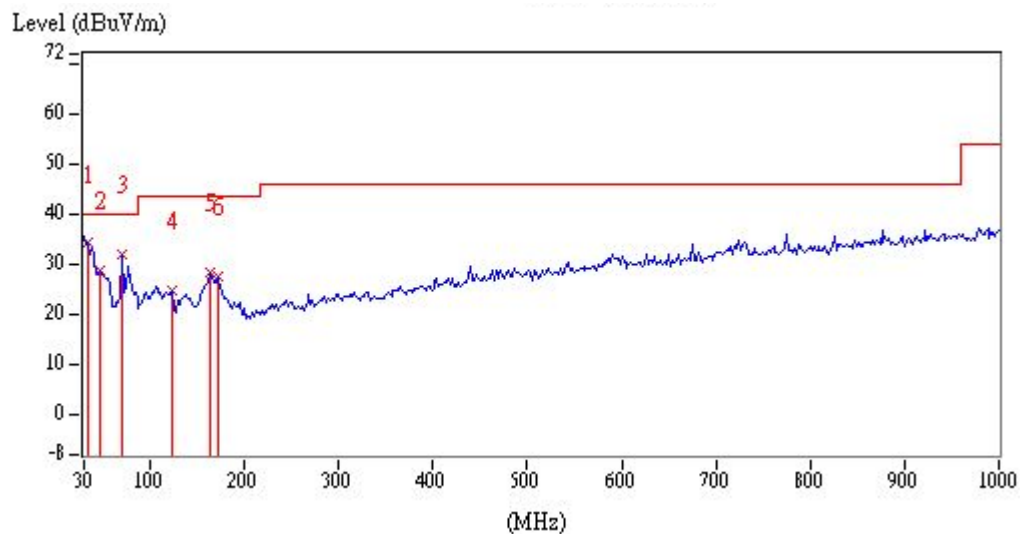

Ant Polarity	Frequency (MHz)	Detector	Factor (dB/m)	Reading (dB μ V)	Corrected Reading (dB μ V/m)	Limit @ 3m (dB μ V/m)	Margin (dB)
Horizontal	30.00	QP	20.75	8.96	29.71	40.00	-10.29
Horizontal	70.74	QP	19.46	6.71	26.17	40.00	-13.83
Horizontal	163.86	QP	21.79	6.51	28.30	43.50	-15.20
Horizontal	222.06	QP	20.08	5.52	25.60	46.00	-20.40
Horizontal	724.52	QP	31.56	5.07	36.63	46.00	-9.37
Horizontal	774.96	QP	32.36	5.18	37.54	46.00	-8.46

Remark: Corr. Factor = Antenna Factor + Cable Loss

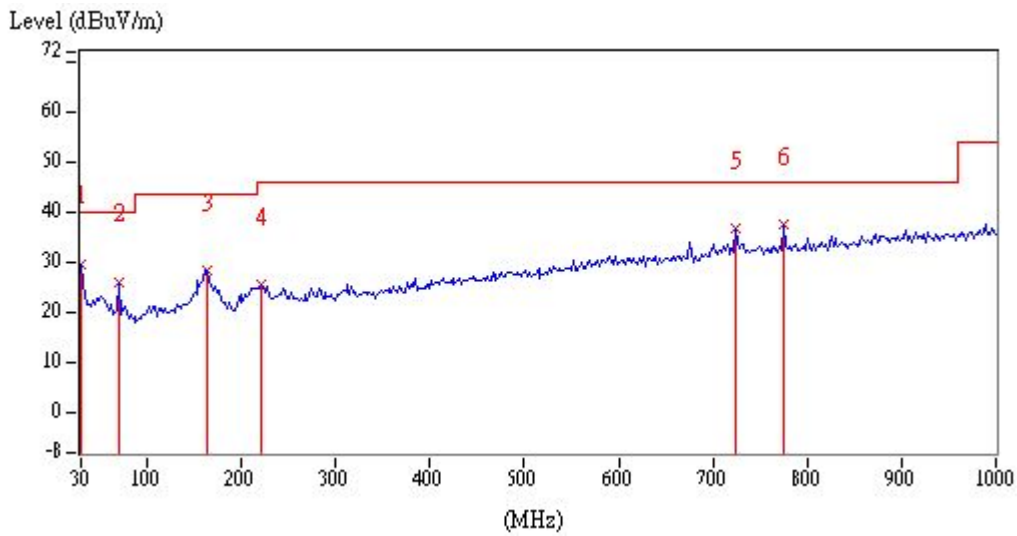

3.6.3 Measurement results: frequency above 1GHz to 25GHz

Mode	Frequency (MHz)	Spectrum Analyzer Detector	Ant. Pol. (H/V)	Correction Factor (dB/m)	Reading (dBμV)	Corrected Reading (dBμV/m)	Limit @ 3 m (dBμV/m)	Margin (dB)
802.11b_Ch1	4824	PK	V	7.50	33.68	41.18	74.00	-32.82
	4988	PK	V	7.72	42.47	50.19	74.00	-23.81
	4824	PK	H	7.50	35.14	42.64	74.00	-31.36
	4988	PK	H	7.72	36.51	44.23	74.00	-29.77
802.11b_Ch6	4874	PK	V	7.57	37.62	45.19	74.00	-28.81
	4988	PK	V	7.72	41.88	49.60	74.00	-24.40
	4874	PK	H	7.57	35.67	43.24	74.00	-30.76
	4988	PK	H	7.72	34.20	41.92	74.00	-32.08
802.11b_Ch11	4924	PK	V	7.63	36.98	44.61	74.00	-29.39
	4988	PK	V	7.72	41.52	49.24	74.00	-24.76
	4924	PK	H	7.63	38.60	46.23	74.00	-27.77
	4988	PK	H	7.72	34.61	42.33	74.00	-31.67
802.11g_Ch1	4824	PK	V	7.50	34.20	41.70	74.00	-32.30
	4988	PK	V	7.72	41.68	49.40	74.00	-24.60
	4824	PK	H	7.50	35.42	42.92	74.00	-31.08
	4988	PK	H	7.72	35.65	43.37	74.00	-30.63
802.11g_Ch6	4874	PK	V	7.57	36.42	43.99	74.00	-30.01
	4988	PK	V	7.72	41.45	49.17	74.00	-24.83
	4874	PK	H	7.57	40.00	47.57	74.00	-26.43
	4988	PK	H	7.72	38.15	45.87	74.00	-28.13
802.11g_Ch11	4924	PK	V	7.63	39.28	46.91	74.00	-27.09
	4988	PK	V	7.72	42.71	50.43	74.00	-23.57
	4924	PK	H	7.63	34.99	42.62	74.00	-31.38
	4988	PK	H	7.72	35.14	42.86	74.00	-31.14
802.11n(HT20)_Ch1	4824	PK	V	7.50	35.27	42.77	74.00	-31.23
	4988	PK	V	7.72	41.08	48.80	74.00	-25.20
	4824	PK	H	7.50	34.19	41.69	74.00	-32.31
	4988	PK	H	7.72	35.18	42.90	74.00	-31.10
802.11n(HT20)_Ch6	4874	PK	V	7.57	35.40	42.97	74.00	-31.03
	4988	PK	V	7.72	42.12	49.84	74.00	-24.16
	4874	PK	H	7.57	35.64	43.21	74.00	-30.79
	4988	PK	H	7.72	35.26	42.98	74.00	-31.02
802.11n(HT20)_Ch11	4924	PK	V	7.63	33.85	41.48	74.00	-32.52
	4988	PK	V	7.72	42.84	50.56	74.00	-23.44
	4924	PK	H	7.63	36.19	43.82	74.00	-30.18
	4988	PK	H	7.72	35.97	43.69	74.00	-30.31

Remark: Correction Factor = Antenna Factor + Cable Loss + High Pass Filter Loss - Pre_Amplifier Gain

TEST REPORT

Mode	Frequency (MHz)	Spectrum Analyzer Detector	Ant. Pol. (H/V)	Correction Factor (dB/m)	Reading (dBμV)	Corrected Reading (dBμV/m)	Limit @ 3 m (dBμV/m)	Margin (dB)
802.11n(HT40)_Ch3	4844	PK	V	7.52	33.69	41.21	74.00	-32.79
	4988	PK	V	7.72	41.28	49.00	74.00	-25.00
	4844	PK	H	7.52	34.21	41.73	74.00	-32.27
	4988	PK	H	7.72	34.93	42.65	74.00	-31.35
802.11n(HT40)_Ch6	4874	PK	V	7.57	34.97	42.54	74.00	-31.46
	4988	PK	V	7.72	41.63	49.35	74.00	-24.65
	4874	PK	H	7.57	34.47	42.04	74.00	-31.96
	4988	PK	H	7.72	34.88	42.60	74.00	-31.40
802.11n(HT40)_Ch9	4904	PK	V	7.61	34.43	42.04	74.00	-31.96
	4988	PK	V	7.72	41.43	49.15	74.00	-24.85
	4904	PK	H	7.61	35.41	43.02	74.00	-30.98
	4988	PK	H	7.72	36.96	44.68	74.00	-29.32

Remark: Correction Factor = Antenna Factor + Cable Loss + High Pass Filter Loss - Pre_Amplifier Gain

4. Emission on Band Edge**4.1 Instrument Setting**

Spectrum Function	Setting
Detector	Peak and Average
RBW	1MHz
VBW	3MHz
Sweep	Auto couple
Restrict bands	2310 MHz ~ 2390 MHz 2483.5 MHz ~ 2500 MHz
Attenuation	Auto

4.2 Test Procedure

The test procedure is the same as Emissions in Restricted Frequency Bands (Radiated emission measurements).

4.3 Operating Environment Condition

Temperature (°C) :	27
Relative Humidity (%) :	57

TEST REPORT

4.4 Test Results

Mode	Frequency (MHz)	Spectrum Analyzer Detector	Ant. Pol. (H/V)	Correction Factor (dB/m)	Reading (dBμV)	Corrected Reading (dBμV/m)	Limit @ 3 m (dBμV/m)	Margin (dB)	Restricted band (MHz)
802.11b	2384.88	PK	H	34.84	22.15	57.00	74	-17.00	2310~2390
	2384.10	AV	H	34.84	8.11	42.94	54	-11.06	
	2497.84	PK	H	35.37	20.66	56.02	74	-17.98	2483.5~2500
	2500.00	AV	H	35.38	7.92	43.30	54	-10.70	
802.11g	2389.82	PK	H	34.87	31.99	66.85	74	-7.15	2310~2390
	2390.00	AV	H	34.87	14.37	49.24	54	-4.76	
	2484.16	PK	H	35.30	29.62	64.92	74	-9.08	2483.5~2500
	2483.56	AV	H	35.30	14.38	49.68	54	-4.32	
802.11n (HT20)	2390.00	PK	H	34.87	28.71	63.58	74	-10.42	2310~2390
	2390.00	AV	H	34.87	13.86	48.72	54	-5.28	
	2483.50	PK	H	35.30	32.71	68.01	74	-5.99	2483.5~2500
	2483.56	AV	H	35.30	12.83	48.13	54	-5.87	
802.11n (HT40)	2390.00	PK	H	34.87	34.76	69.63	74	-4.37	2310~2390
	2389.52	AV	H	34.86	18.55	53.42	54	-0.58	
	2484.46	PK	H	35.30	34.48	69.79	74	-4.21	2483.5~2500
	2484.60	AV	H	35.30	16.92	52.22	54	-1.78	

Remark: Correction Factor = Antenna Factor + Cable Loss

Chain 0: Restricted Band Bandedge @ 802.11b Mode Ch1 PK

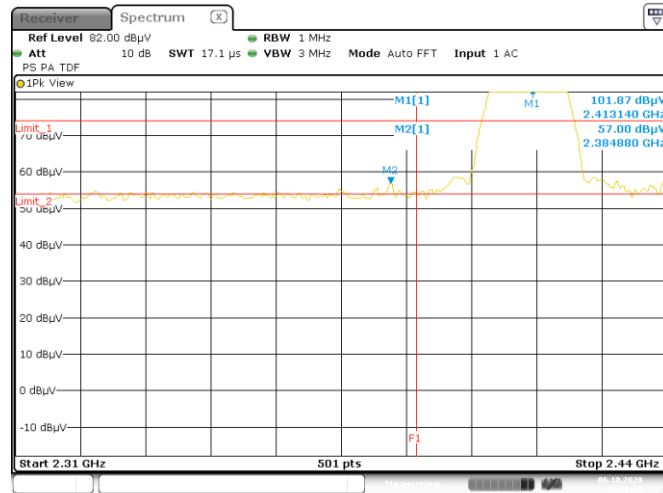

Chain 0: Restricted Band Bandedge @ 802.11b Mode Ch1 AV

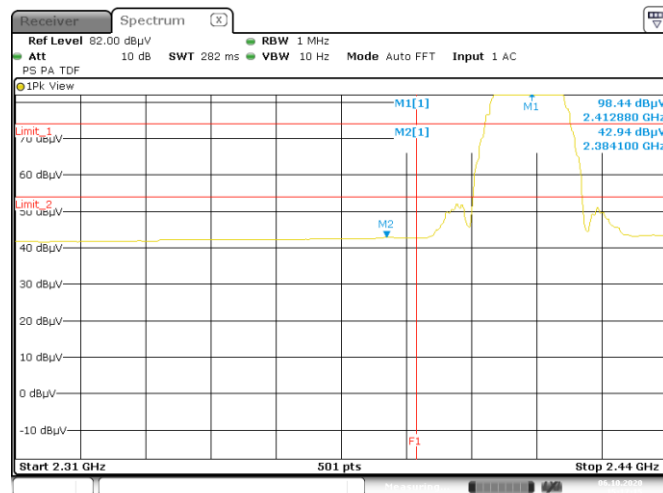

Chain 0: Restricted Band Bandedge @ 802.11b Mode Ch11 PK

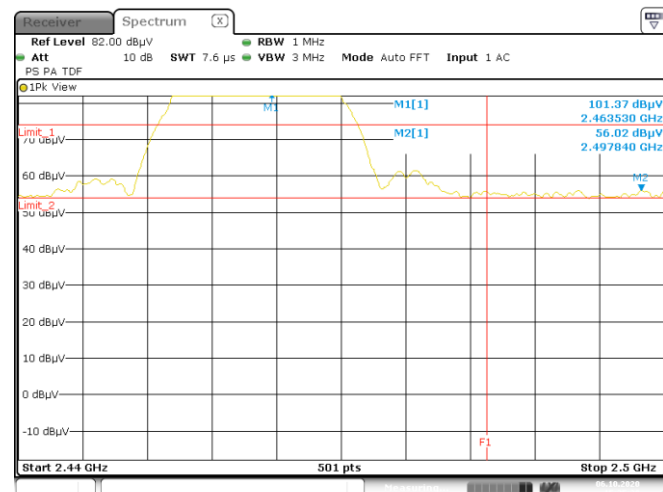

Chain 0: Restricted Band Bandedge @ 802.11b Mode Ch11 AV

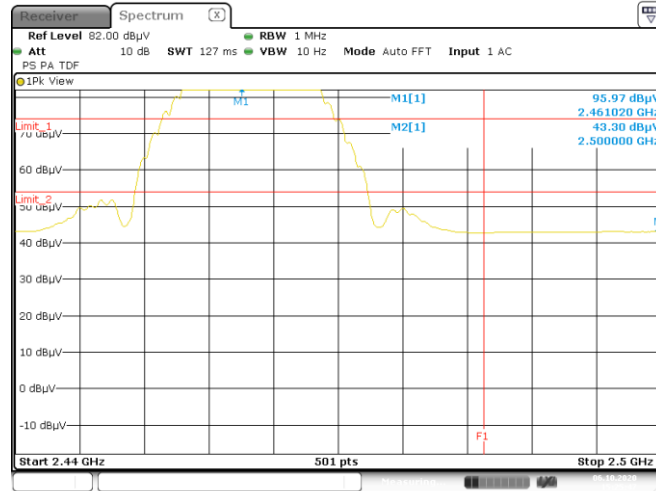

Date: 6.OCT.2020 15:25:48

Chain 0: Restricted Band Bandedge @ 802.11g Mode Ch1 PK

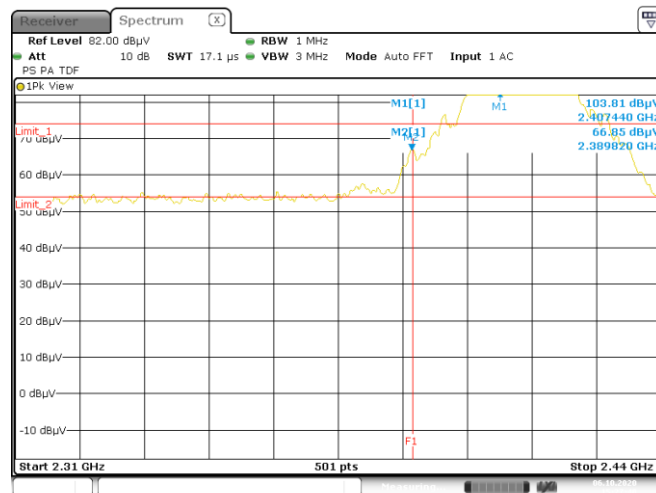

Date: 6.OCT.2020 15:27:40

Chain 0: Restricted Band Bandedge @ 802.11g Mode Ch1 AV

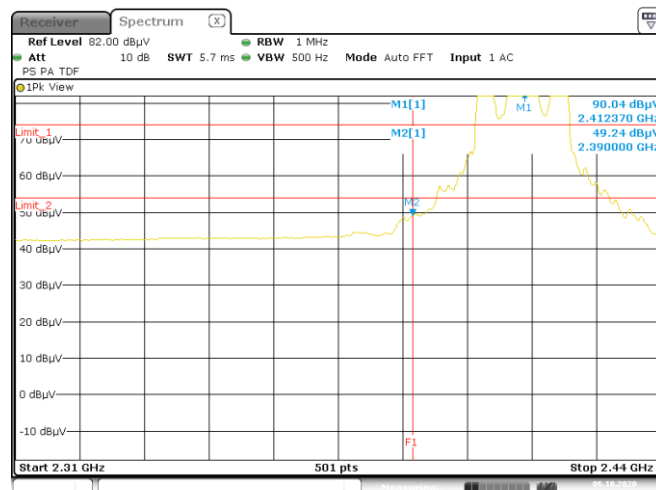

Date: 6.OCT.2020 15:28:35

Chain 0: Restricted Band Bandedge @ 802.11g Mode Ch11 PK

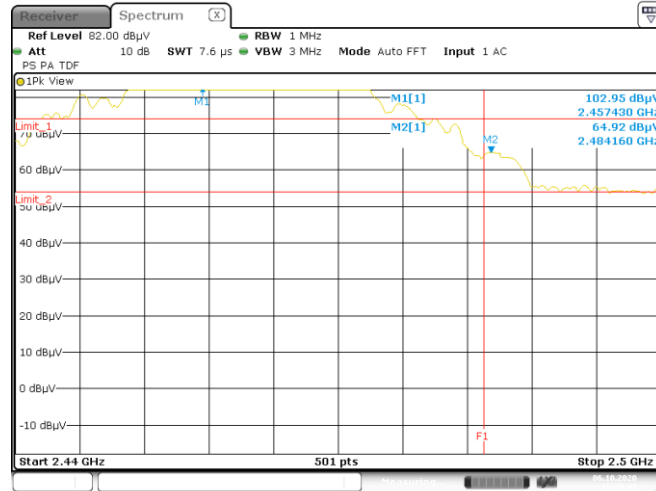

Date: 6.OCT.2020 15:29:47

Chain 0: Restricted Band Bandedge @ 802.11g Mode Ch11 AV

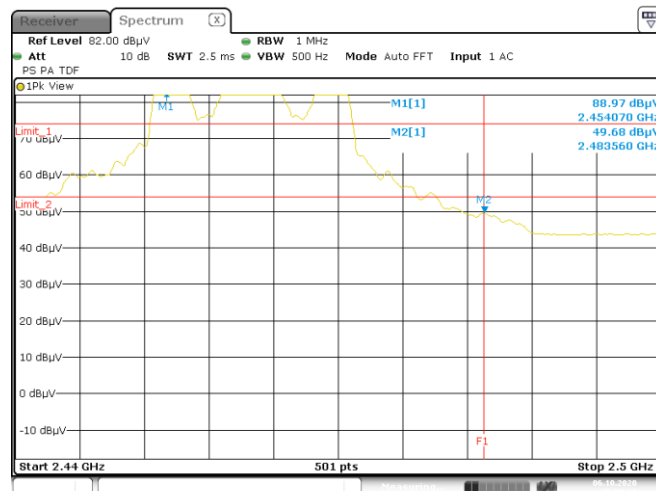

Date: 6.OCT.2020 15:30:11

Chain 0: Restricted Band Bandedge @ 802.11n(HT20) Mode Ch1 PK

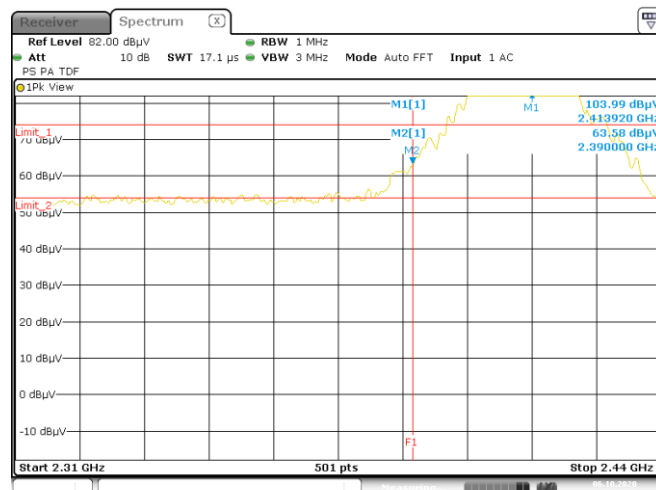

Date: 6.OCT.2020 15:32:20

Chain 0: Restricted Band Bandedge @ 802.11n(HT20) Mode Ch1 AV

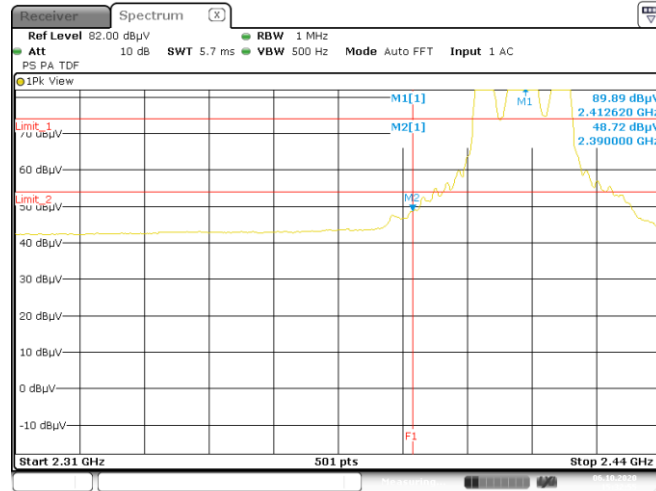

Date: 6.OCT.2020 15:32:55

Chain 0: Restricted Band Bandedge @ 802.11n(HT20) Mode Ch11 PK

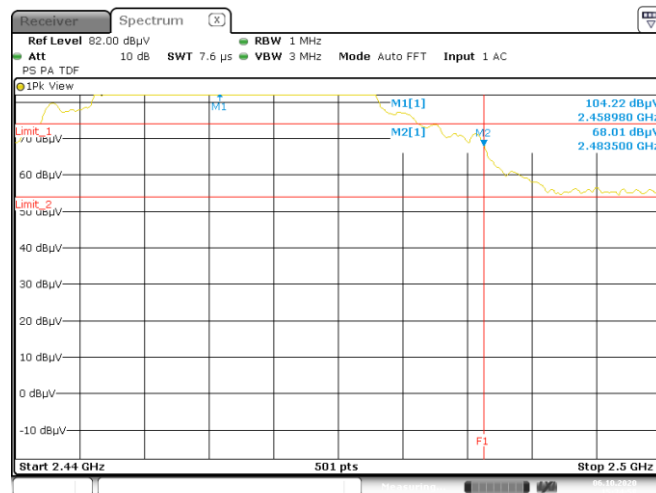

Date: 6.OCT.2020 15:34:59

Chain 0: Restricted Band Bandedge @ 802.11n(HT20) Mode Ch11 AV

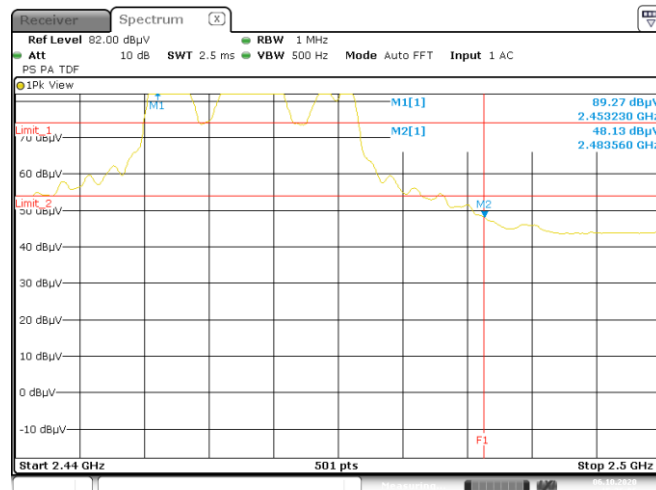

Date: 6.OCT.2020 15:36:06

Chain 0: Restricted Band Bandedge @ 802.11n(HT40) Mode Ch3 PK

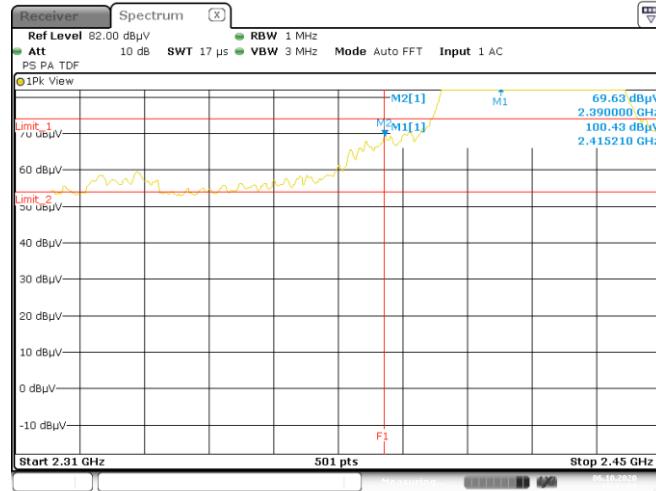

Date: 6.OCT.2020 15:41:59

Chain 0: Restricted Band Bandedge @ 802.11n(HT40) Mode Ch3 AV

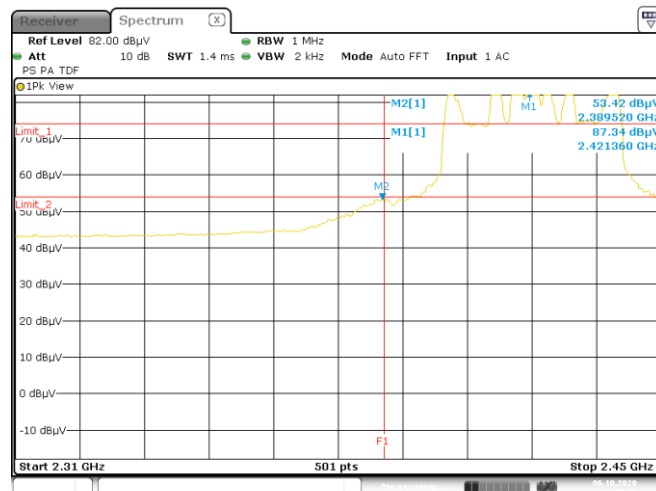

Date: 6.OCT.2020 15:43:06

Chain 0: Restricted Band Bandedge @ 802.11n(HT40) Mode Ch9 PK

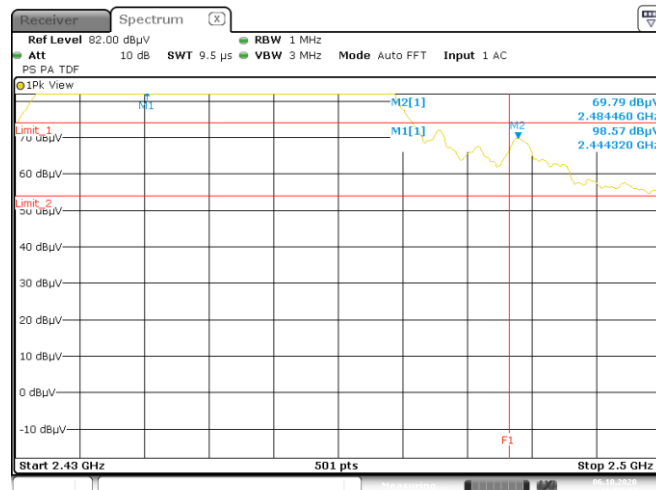

Date: 6.OCT.2020 16:03:08

5. AC Power Line Conducted Emission

5.1 Measuring instrument setting

Receiver Function	Setting
Detector	QP
Start frequency	0.15MHz
Stop frequency	30MHz
IF bandwidth	9 kHz
Attenuation	10dB

5.2 Test Procedure

Step 1	Configure the EUT according to ANSI C63.10:2013. The EUT or host of EHT has to be placed 0.4 meter far from the conducting wall of the shielding room and at least 80 centimeters from any other grounded conducting surface.
Step 2	Connect EUT or host of EUT to the power mains through a line impedance stabilization network.
Step 3	All the companion devices are connected to the other LISN. The LISN should provide 50Uh/50ohms coupling impedance.
Step 4	The frequency range from 150 kHz to 30MHz was searched.
Step 5	Set the test-receiver system to peak detector and specified bandwidth with maximum hold mode.
Step 6	The measurement has to be done between each power line and ground at the power terminal.

5.3 Test Diagram

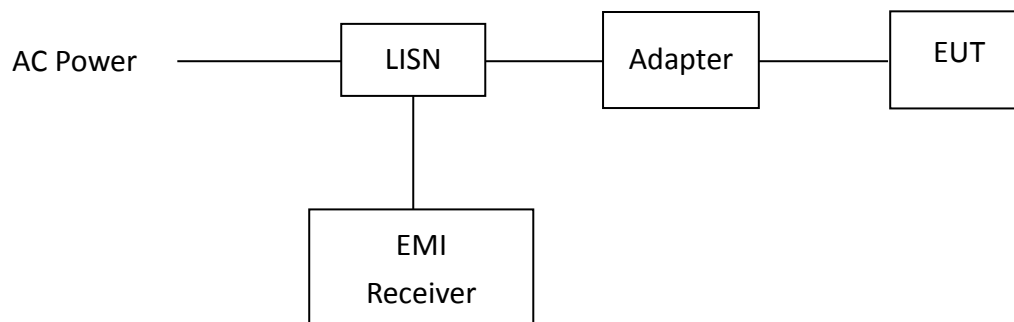

5.4 Limit

Frequency (MHz)	Conducted Limit (dBuV)	
	Q.P.	Ave.
0.15~0.50	66 – 56	56 – 46
0.50~5.00	56	46
5.00~30.0	60	50

5.5 Operating Environment Condition

Temperature (°C) :	25
Relative Humidity (%) :	56
Atmospheric Pressure (hPa) :	1007

TEST REPORT

5.6 Test Results

Phase: Live Line
 Model No.: Milano XL
 Test Condition: Tx mode

Frequency (MHz)	Corr. Factor (dB)	Reading QP (dBuV)	Level QP (dBuV)	Limit QP (dBuV)	Reading AV (dBuV)	Level AV (dBuV)	Limit AV (dBuV)	Margin (dB)	
								QP	AV
0.253	9.72	28.83	38.55	61.64	27.93	37.65	51.64	-23.09	-13.99
0.449	9.78	21.02	30.80	56.89	8.11	17.89	46.89	-26.09	-29.00
0.486	9.79	19.40	29.19	56.23	11.26	21.05	46.23	-27.04	-25.18
0.579	9.80	16.93	26.72	56.00	7.59	17.39	46.00	-29.28	-28.61
4.292	9.88	21.79	31.66	56.00	19.31	29.19	46.00	-24.34	-16.81
29.841	10.85	33.87	44.72	60.00	33.25	44.10	50.00	-15.28	-5.90

Remark:

1. Corr. Factor (dB) = LISN Factor (dB) + Cable Loss (dB)
2. Level (dBuV) = Corr. Factor (dB) + Reading (dBuV)
3. Margin (dB) = Level (dBuV) – Limit (dBuV)

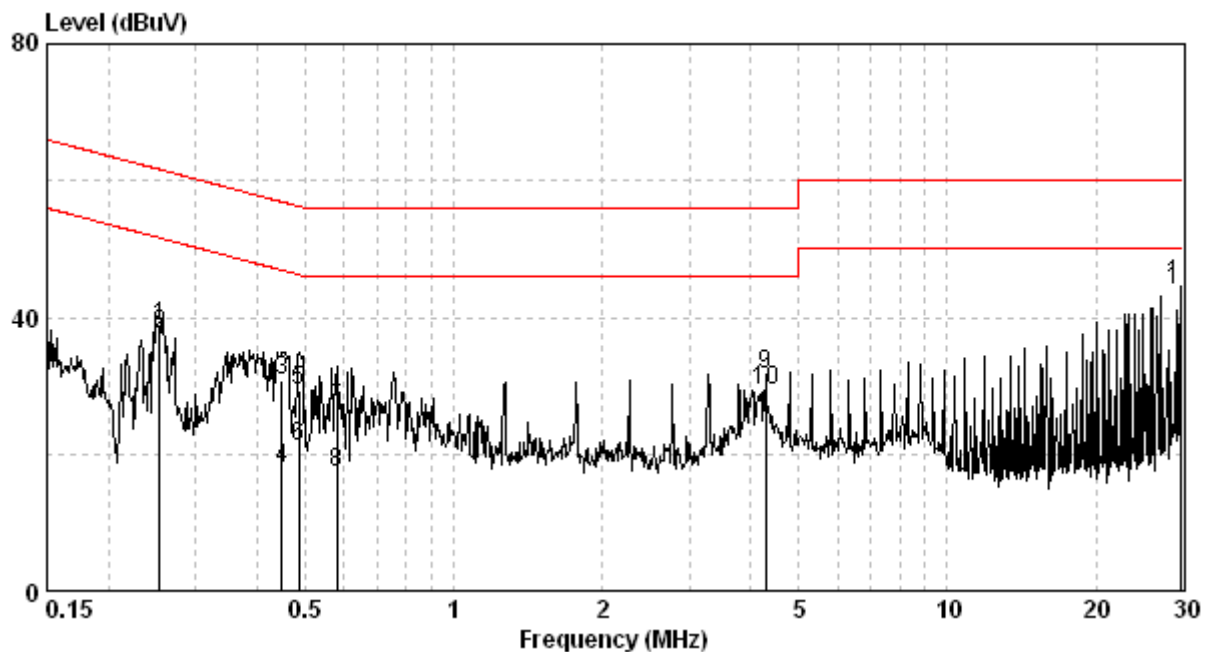

TEST REPORT

Phase: Neutral Line
 Model No.: Milano XL
 Test Condition: Tx mode

Frequency (MHz)	Corr. Factor (dB)	Reading QP (dBuV)	Level QP (dBuV)	Limit QP (dBuV)	Reading AV (dBuV)	Level AV (dBuV)	Limit AV (dBuV)	Margin (dB)	
								QP	AV
0.252	9.71	29.51	39.22	61.68	28.57	38.28	51.68	-22.47	-13.41
0.483	9.79	18.26	28.05	56.29	9.52	19.31	46.29	-28.24	-26.98
0.567	9.79	17.71	27.50	56.00	10.77	20.56	46.00	-28.50	-25.44
0.755	9.80	19.69	29.48	56.00	17.91	27.70	46.00	-26.52	-18.30
4.292	9.87	16.77	26.64	56.00	10.72	20.59	46.00	-29.36	-25.41
30.000	10.99	33.12	44.11	60.00	32.24	43.23	50.00	-15.89	-6.77

Remark:

1. Corr. Factor (dB) = LISN Factor (dB) + Cable Loss (dB)
2. Level (dBuV) = Corr. Factor (dB) + Reading (dBuV)
3. Margin (dB) = Level (dBuV) – Limit (dBuV)

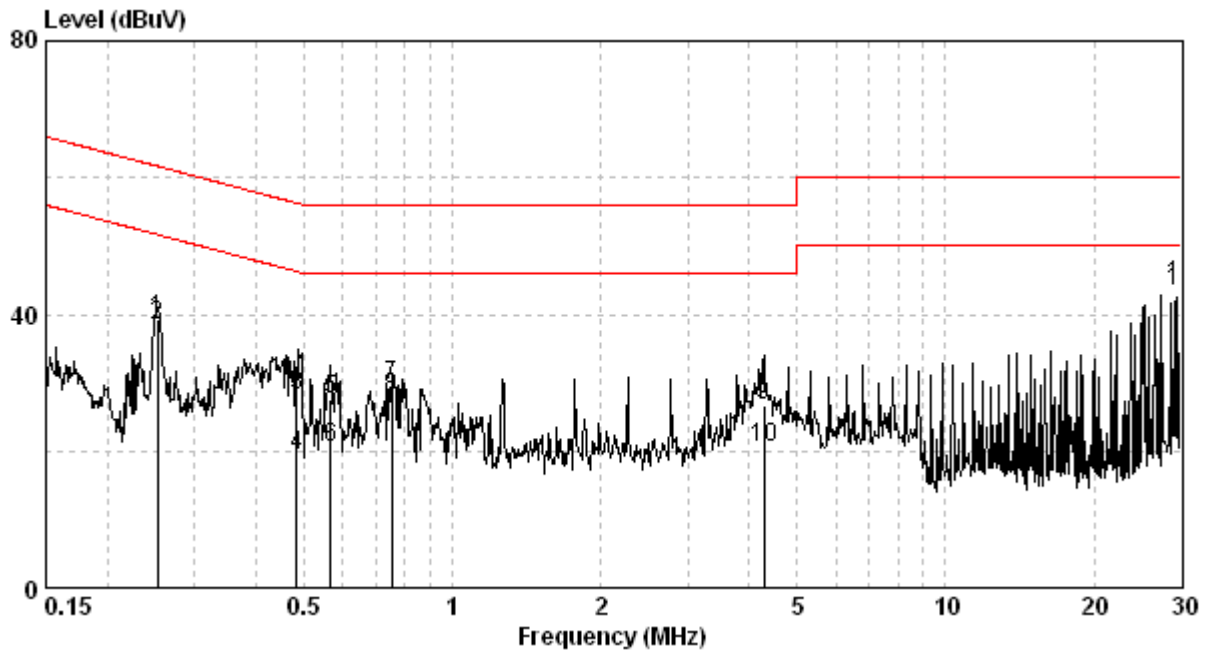

Appendix A: Test equipment list

Test Equipment/ Test site	Brand	Model No.	Serial No.	Calibration Date	Next Calibration Date
EMI Test Receiver	Rohde & Schwarz	ESR-7	101232	2020/01/18	2021/01/16
Spectrum Analyzer	R&S	FSP30	100137	2020/08/25	2021/08/24
Signal Analyzer	Agilent	N9030A	MY51380492	2020/08/17	2021/08/16
Active Loop Antenna	SCHWARZBECK MESS-ELEKTRONIC	FMZB1519	1519-067	2020/04/13	2021/04/12
Broadband Antenna	SHWARZBECK	VULB 9168	9168-172	2020/06/02	2021/06/01
Horn Antenna	SHWARZBECK	BBHA 9120 D	9120D-456	2020/01/20	2021/01/18
Horn Antenna	SCHWARZBECK	BBHA 9170	BBHA9170159	2020/08/20	2023/08/19
Pre-Amplifier	SCHWARZBECK	BBV9718	9718-004	2019/10/16	2020/10/14
Pre-Amplifier	SCHWARZBECK	BBV9718	9718-004	2020/10/15	2021/10/14
Pre-Amplifier	EMCI	EMC184045SE	980512	2020/06/01	2021/05/31
RF Cable	SUHNER	SUCOFLEX 102	CB0006	2020/04/30	2021/04/29
Hight Pass Filter	Reactel	7HS-3G/18G-S11	N/A	2020/05/27	2021/05/26
966-2(A) Cable	SUHNER	SMA / EX 100	N/A	2020/08/17	2021/08/16
966-2(B) Cable	SUHNER	SUCOFLEX 104P	CB0005	2020/08/17	2021/08/16
Power Meter	Anritsu	ML2495A	0844001	2019/10/23	2020/10/21
Power Sensor	Anritsu	MA2411B	0738452	2019/10/23	2020/10/21
966-2_3m Semi-Anechoic Chamber	966_2	CEM-966_2	N/A	2020/02/23	2021/02/22
EMI Test Receiver	R&S	ESCI	100059	2019/11/05	2020/11/03
LISN	R&S	ENV216	101160	2020/07/17	2021/07/16
CON-2 Cable	SUHNER	EMCCFD300-BM -NM-6000	170502	2020/04/30	2021/04/29
Test software	Audix	e3	V4.20040112L	NCR	NCR

Note: No Calibration Required (NCR).

Appendix B: Measurement Uncertainty

This uncertainty represents an expanded uncertainty expressed at approximately the 95 % confidence level using a coverage factor of k=2.

Item	Uncertainty
Vertically polarized radiated disturbances from 30MHz~1GHz in a semi-anechoic chamber at a distance of 3m	5.10 dB
Horizontally polarized radiated disturbances from 30MHz~1GHz in a semi-anechoic chamber at a distance of 3m	5.19 dB
Vertically polarized Radiated disturbances from 1GHz~18GHz in a semi-anechoic chamber at a distance of 3m	4.29 dB
Horizontally polarized Radiated disturbances from 1GHz~18GHz in a semi-anechoic chamber at a distance of 3m	4.29 dB
Vertically polarized Radiated disturbances from 18GHz~26.5GHz in a semi-anechoic chamber at a distance of 1m	2.45 dB
Horizontally polarized Radiated disturbances from 18GHz~26.5GHz in a semi-anechoic chamber at a distance of 1m	2.45 dB
Radiated disturbances from 9kHz~30MHz in a semi-anechoic chamber at a distance of 3m	3.32 dB
Emission on the Band Edge Test	4.29 dB
Minimum 6 dB Bandwidth	7.69 %
Maximum Peak Conducted Output Power	0.37 dB
Power Spectral Density	1.15 dB
Emissions In Non-Restricted Frequency Bands	1.15 dB
AC Power Line Conducted Emission	2.52 dB