

## Zykronix Inc. Taiwan Branch

# TEST REPORT

**REPORT NUMBER**  
201000189TWN-001

**ISSUE DATE**  
Nov. 02, 2020

**PAGES**  
38

© 2020 INTERTEK



# FCC Class II Chang

## TEST REPORT

<b>Applicant:</b>	Zykronix Inc. Taiwan Branch 14F. -8, No. 3, Sec. 4, New Taipei Blvd., Xinzhuang Dist., New Taipei City, Taiwan
<b>Product:</b>	W-LAN + Bluetooth Module
<b>Model No.:</b>	LBEE5ZZ1PJ
<b>Brand Name:</b>	N/A
<b>FCC ID:</b>	2AGRR-LBEE5ZZ1PJ
<b>Test Method/ Standard:</b>	47 CFR FCC Part 15.247 & ANSI C63.10 2013 KDB 558074 D01 v05r02
<b>Test By:</b>	Intertek Testing Services Taiwan Ltd., Hsinchu Laboratory No. 11, Lane 275, Ko-Nan 1 Street, Chia-Tung Li, Shiang-Shan District, Hsinchu City, Taiwan



Prepared and Checked by:

*Zero chen*

---

Zero Chen  
Engineer

Approved by:

*Durant Wei*

---

Durant Wei  
Engineer

This report is for the exclusive use of Intertek's Client and is provided pursuant to the agreement between Intertek and its Client. Intertek's responsibility and liability are limited to the terms and conditions of the agreement. Intertek assumes no liability to any party, other than to the Client in accordance with the agreement, for any loss, expense or damage occasioned by the use of this report. Only the Client is authorized to permit copying or distribution of this report and then only in its entirety. Any use of the Intertek name or one of its marks for the sale or advertisement of the tested material, product or service must first be approved in writing by Intertek. The observations and test results in this report are relevant only to the sample tested. This report by itself does not imply that the material, product, or service is or has ever been under an Intertek certification program.

### Revision History

Report No.	Issue Date	Revision Summary
201000189TWN-001	Nov. 02, 2020	Original report (This case is to add hosts.)

## Table of Contents

1. General Information .....	6
1.1 Identification of the EUT .....	6
1.2 Additional information about the EUT .....	6
1.3 Antenna description .....	7
1.4 Operation mode .....	7
1.5 Peripherals equipment .....	7
2. Minimum 6 dB Bandwidth .....	8
2.1 Instrument Setting.....	8
2.2 Test Procedure .....	8
2.3 Test Diagram .....	8
2.4 Limit.....	8
2.5 Operating Environment Condition .....	8
2.6 Test Results .....	9
3. Maximum Peak Conducted Output Power .....	11
3.1 Instrument Setting.....	11
3.2 Test Procedure .....	11
3.3 Test Diagram .....	11
3.4 Limit.....	11
3.5 Operating Environment Condition .....	11
3.6 Test Results .....	12
4. Power Spectral Density.....	13
4.1 Instrument Setting.....	13
4.2 Test Procedure .....	13
4.3 Test Diagram .....	13
4.4 Limit.....	13
4.5 Operating Environment Condition .....	13
4.6 Test Results .....	14
5. Emissions in Non-Restricted Frequency Bands .....	16
5.1 Instruments Setting .....	16
5.2 Test Procedure .....	16
5.3 Test Diagram .....	16
5.4 Limit.....	16
5.5 Operating Environment Condition .....	16
5.6 Test Results .....	17
6. Emissions in Restricted Frequency Bands (Radiated emission measurements) .....	20
6.1 Instrument Setting.....	20
6.2 Test Procedure .....	20
6.3 Test Diagram .....	21
6.3.1 Radiated emission from 9kHz to 30MHz uses Loop Antenna: .....	21

**TEST REPORT**

- 6.3.2 Radiated emission below 1GHz using Bilog Antenna ..... 21
- 6.3.3 Radiated emission above 1GHz using Horn Antenna ..... 22
- 6.4 Limit ..... 22
- 6.5 Operating Environment Condition ..... 22
- 6.6 Test Result..... 23
  
- 7. Emission on Band Edge..... 29
  - 7.1 Instrument Setting..... 29
  - 7.2 Test Procedure ..... 29
  - 7.3 Operating Environment Condition ..... 29
  - 7.4 Test Results ..... 30
  
- 8. AC Power Line Conducted Emission ..... 33
  - 8.1 Measuring instrument setting..... 33
  - 8.2 Test Procedure ..... 33
  - 8.3 Test Diagram ..... 33
  - 8.4 Limit..... 34
  - 8.5 Operating Environment Condition ..... 34
  - 8.6 Test Results ..... 35
  
- Appendix A: Test equipment list..... 37
  
- Appendix B: Measurement Uncertainty..... 38

### Summary of Test Data

Test Requirement	Applicable Rule (Section 15.247)	Result
Minimum 6 dB Bandwidth	15.247(a)(2)	Pass
Maximum Peak Conducted Output Power	15.247(b)(3)	Pass
Power Spectral Density	15.247(e)	Pass
Emissions In Non-Restricted Frequency Bands	15.247(d)	Pass
Emissions In Restricted Frequency Bands (Radiated emission measurements)	15.247(d), 15.205, 15.209	Pass
Emission On The Band Edge	15.247(d), 15.205	Pass
AC Power Line Conducted Emission	15.207	Pass
Antenna Requirement	15.203	Pass

Note: Please note that the test results with statement of conformity, the decision rules which are based on: Safety Testing: the specification, standard or IEC Guide 115.

Other Testing: the specification, standard and not taking into account the measurement uncertainty.

## 1. General Information

### 1.1 Identification of the EUT

<b>Product:</b>	15.6" Touch Screen Controller
<b>Model No.:</b>	Milano XL
<b>Operating Frequency:</b>	2402 MHz ~ 2480 MHz
<b>Channel Number:</b>	40 channels
<b>Frequency of Each Channel:</b>	2402+2 k, k=0 ~ 39
<b>Rated Power:</b>	DC 24 V from adapter
<b>Power Cord:</b>	N/A
<b>Sample receiving date:</b>	Sep. 14, 2020
<b>Sample condition:</b>	Workable
<b>Test Date(s):</b>	Oct. 06, 2020 ~ Oct. 20, 2020

### 1.2 Additional information about the Hosts

Brand Name	Model Name	Model Number	Different
Zykronix	15.6" Touch Screen Controller	Milano XL	The Model is main model
Zykronix	11.6" Touch Screen Controller	Symphony XL	The difference from the main model is the screen size
Zykronix	11.6" Touch Screen Controller	Symphony II	The difference from the main model is the screen size & has no LED
Zykronix	8.0" Touch Screen Controller	Melody XL	The difference from the main model is the screen size
Zykronix	8.0" Touch Screen Controller	Melody II	The difference from the main model is the screen size & has no LED
Zykronix	6.0" Touch Screen Controller	Giulia	The difference from the main model is the screen size & has no LED

### 1.3 Antenna description

Antenna Gain : 2.15 dBi  
Antenna Type : FPC antenna  
Connector Type : I-Pex

### 1.4 Operation mode

The EUT was supplied with DC 24 V from adapter (Test voltage: 120Vac, 60Hz).

EUT connected to Notebook PC & Wireless AP via Micro USB Cable & LAN, executing “Qualcomm Radio Control Tool” and select different frequency and modulation.

### 1.5 Peripherals equipment

Peripherals	Brand	Model No.	Serial No.	Data cable
Notebook PC	HP	HP ProBook 440 G3	5CD8021S9H	Micro USB Cable 0.8 meter × 1
Wireless AP	BUFFALO	WZR-AGL300NH	N/A	RJ-45 STP Cat.5 0.8 meter × 2
Adapter	N/A	ADP-85NB A	N/A	N/A



## 2. Minimum 6 dB Bandwidth

### 2.1 Instrument Setting

Spectrum Parameter	Setting
Detector	Peak
RBW	100kHz
VBW	$\geq 3 \times \text{RBW}$
Sweep	Auto couple
Trace	Allow the trace to stabilize.
Span	Between two times and five times the occupied bandwidth
Attenuation	Auto

### 2.2 Test Procedure

Step 1	The transmitter output was connected to the spectrum analyzer.
Step 2	Test was performed accordance with ANSI C63.10.
Step 3	Measure the maximum width of the emission that is constrained by the frequencies associated with the two outermost amplitude points (upper and lower frequencies) that are attenuated by 6 dB relative to the maximum level measured in the fundamental emission

### 2.3 Test Diagram

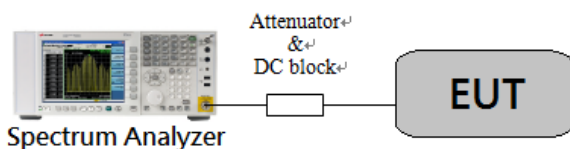

### 2.4 Limit

The minimum 6 dB bandwidth shall be at least 500 kHz.

### 2.5 Operating Environment Condition

Temperature (°C) :	25
Relative Humidity (%) :	56

## 2.6 Test Results

### Single TX Chain 0

Mode	Channel	Frequency (MHz)	6dB Bandwidth (MHz)	Limit (MHz)	Result
BLE	0	2402	0.655	>0.5	Pass
	19	2440	0.660	>0.5	Pass
	39	2480	0.656	>0.5	Pass

## Chain 0: 6dB Bandwidth @ Lower Energy Mode Ch 0

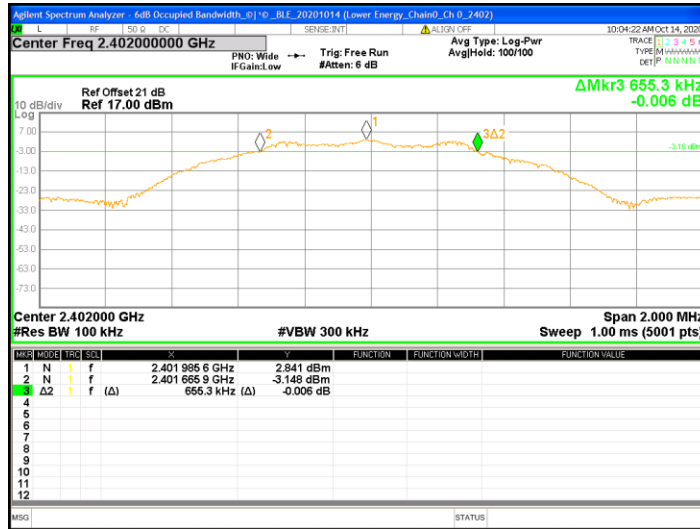

## Chain 0: 6dB Bandwidth @ Lower Energy Mode Ch 19

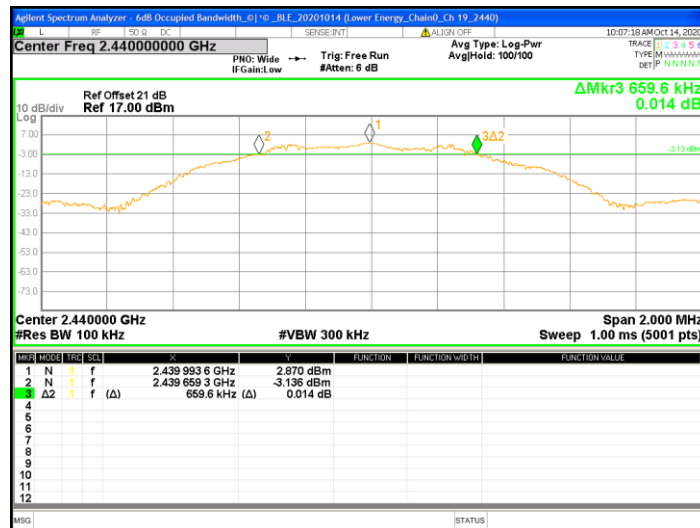

## Chain 0: 6dB Bandwidth @ Lower Energy Mode Ch 39

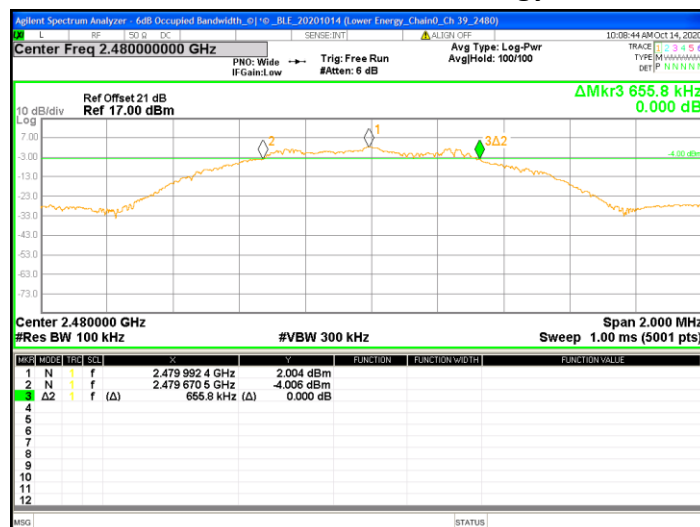

### 3. Maximum Peak Conducted Output Power

#### 3.1 Instrument Setting

Power Meter Parameter	Setting
Bandwidth	65MHz bandwidth is greater than the EUT emission bandwidth
Detector	Peak & Average

#### 3.2 Test Procedure

The preferred methodology is to use integrated average power measurements, as described in 11.9.2 and 11.13.3 of ANSI C63.10. The peak integrated band power methods of 11.9.1.2 and 11.13.3.2 of ANSI C63.10 are not applicable for FCC compliance testing purposes.

#### 3.3 Test Diagram

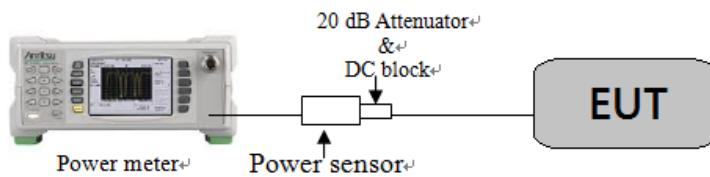

#### 3.4 Limit

For systems using digital modulation in the 2400-2483.5 MHz: 1 Watt (30dBm)

#### 3.5 Operating Environment Condition

Temperature (°C) :	25
Relative Humidity (%) :	56

**3.6 Test Results****Single Tx  
Chain 0**

Mode	Channel	Frequency (MHz)	Output Power (AV) (dBm)	Total Power (AV) (mW)	Maximum power (PK) (dBm)	Maximum power (PK) (mW)	Limit (dBm)	Margin (dB)
BLE	0	2402	3.31	2.14	4.15	2.60	30	-25.85
	19	2440	3.07	2.03	4.12	2.58	30	-25.88
	39	2480	2.25	1.68	3.19	2.08	30	-26.81

## 4. Power Spectral Density

### 4.1 Instrument Setting

Spectrum Function	Setting
Detector	Peak
RBW	$\geq 3$ kHz
VBW	$\geq 3 \times$ RBW
Sweep	Auto couple
Trace	Max hold
Span	1.5 times x 6dB bandwidth
Attenuation	Auto

### 4.2 Test Procedure

Step 1	Test procedure refer to subclause 11.10 of ANSI C63.10.
Step 2	Using the maximum conducted output power in the fundamental emission demonstrates compliance. The EUT must be configured to transmit continuously at full power over the measurement duration.
Step 3	Use the peak marker function to determine the maximum amplitude level within the RBW.

### 4.3 Test Diagram

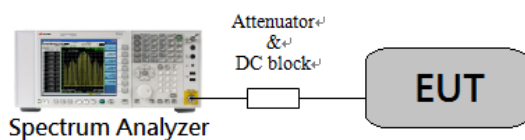

### 4.4 Limit

For digitally modulated systems, the power spectral density conducted from the intentional radiator to the antenna shall not be greater than 8 dBm in any 3 kHz band during any time interval of continuous transmission

### 4.5 Operating Environment Condition

Temperature (°C) :	25
Relative Humidity (%) :	56

#### 4.6 Test Results

##### Single TX

##### Chain 0

Mode	Channel	Frequency (MHz)	RBW factor	PSD in 10kHz	PSD in 3kHz		Limit (dBm)	Margin (dB)
					(dBm)	(mW)		
BLE	0	2402	5.23	-3.57	-8.79	0.13	8	-16.79
	19	2440	5.23	-3.66	-8.88	0.13	8	-16.88
	39	2480	5.23	-4.64	-9.87	0.10	8	-17.87

### Chain 0: Power Spectral Density @ Lower Energy Mode Ch 0

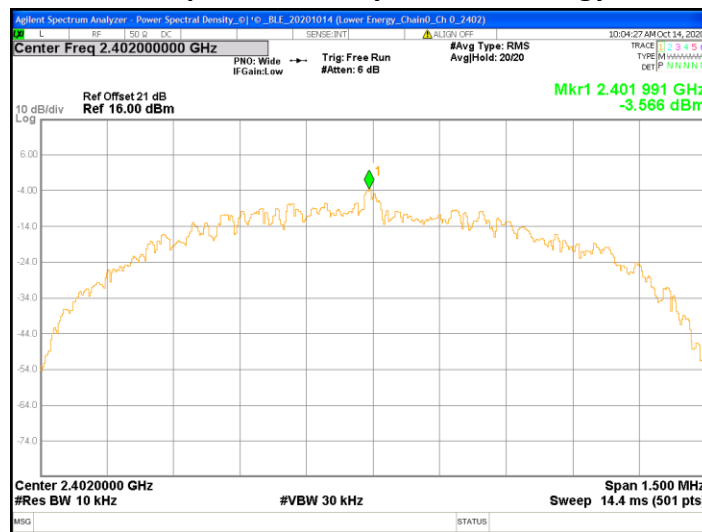

### Chain 0: Power Spectral Density @ Lower Energy Mode Ch 19

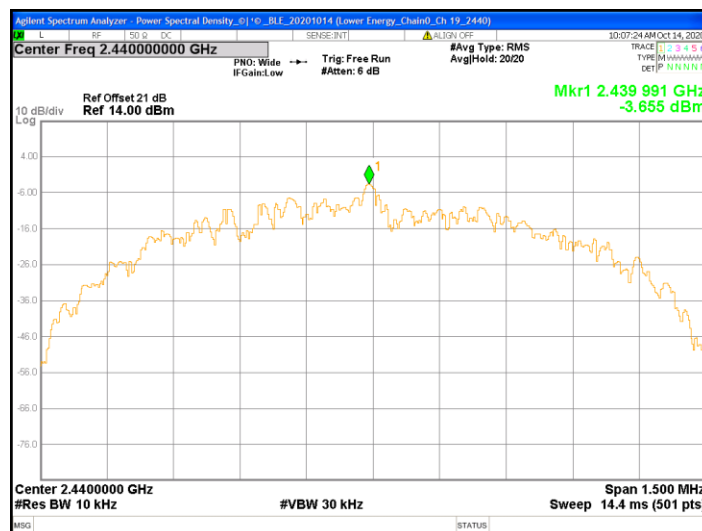

### Chain 0: Power Spectral Density @ Lower Energy Mode Ch 39

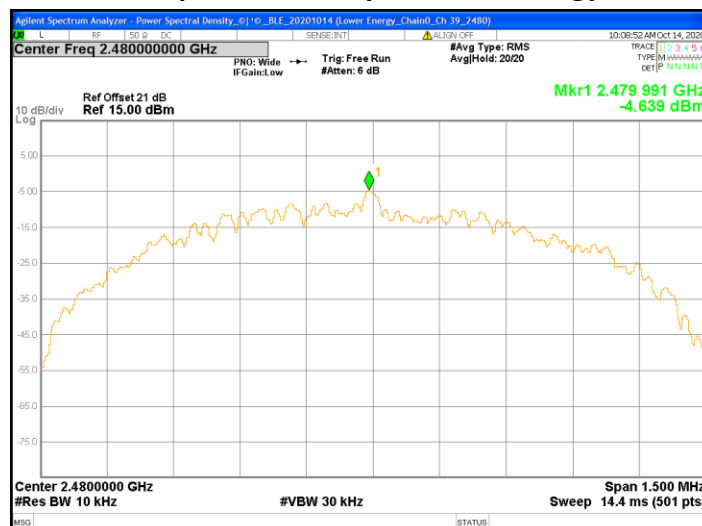



## 5. Emissions in Non-Restricted Frequency Bands

### 5.1 Instruments Setting

Spectrum Function	Setting (Reference Level)	Setting (Emission Level)
Detector	Peak	Peak
RBW	$\geq 100$ kHz	$\geq 100$ kHz
VBW	$\geq 3 \times$ RBW	$\geq 3 \times$ RBW
Sweep	Auto couple	Auto couple
Trace	Max hold	Max hold
Span	$\geq 1.5$ time 6dB bandwidth	X
Attenuation	Auto	Auto

### 5.2 Test Procedure

- Step 1 The procedure was used in antenna-port conducted and connected to the spectrum analyzer.
- Step 2 Set instrument center frequency to center frequency.
- Step 3 Use the parameter configured in subclause 11.11 of ANSI C63.10 to measure.
- Step 4 Use the peak marker function to determine the maximum amplitude level.

### 5.3 Test Diagram

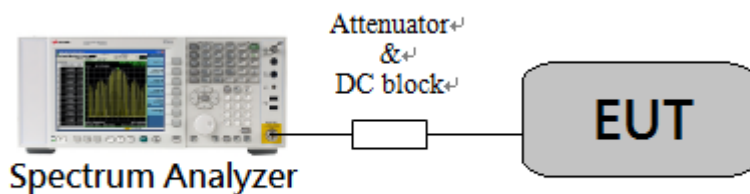

### 5.4 Limit

The peak output power measured in any 100 kHz bandwidth outside of the authorized frequency band shall be attenuated by at least 20 dB relative to the maximum in-band peak PSD level in 100 kHz

### 5.5 Operating Environment Condition

Temperature (°C) :	25
Relative Humidity (%) :	56

## 5.6 Test Results

### Chain 0: Conducted Spurious @ Lower Energy Mode Ch 0

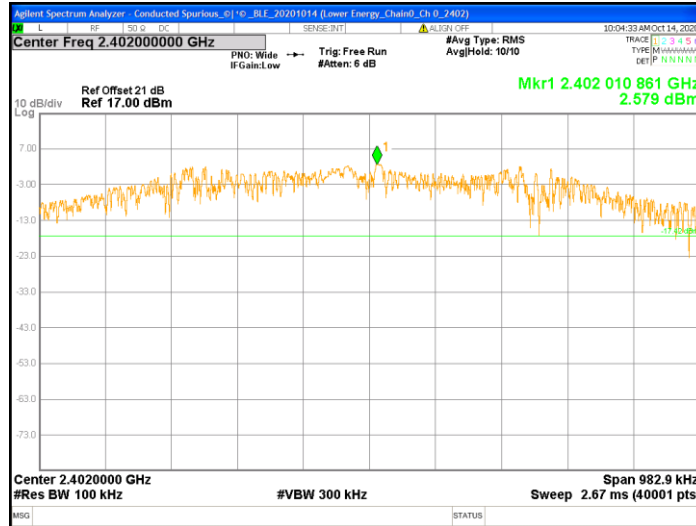

### Chain 0: Conducted Spurious @ Lower Energy Mode Ch 0

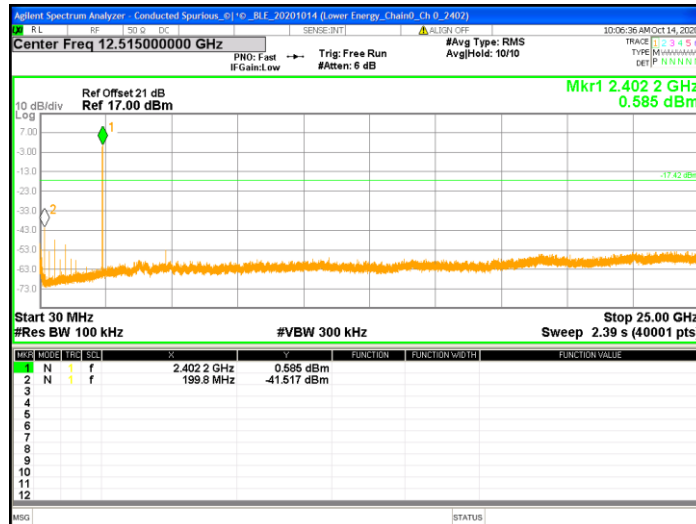

### Chain 0: Conducted Spurious @ Lower Energy Mode Ch 19

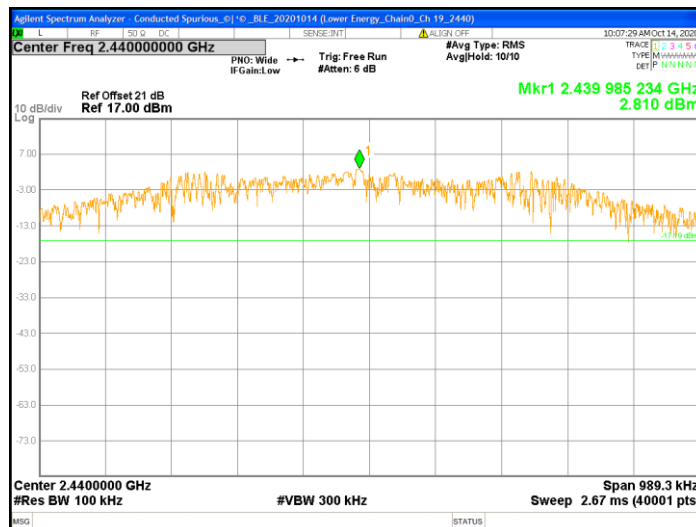

### Chain 0: Conducted Spurious @ Lower Energy Mode Ch 19

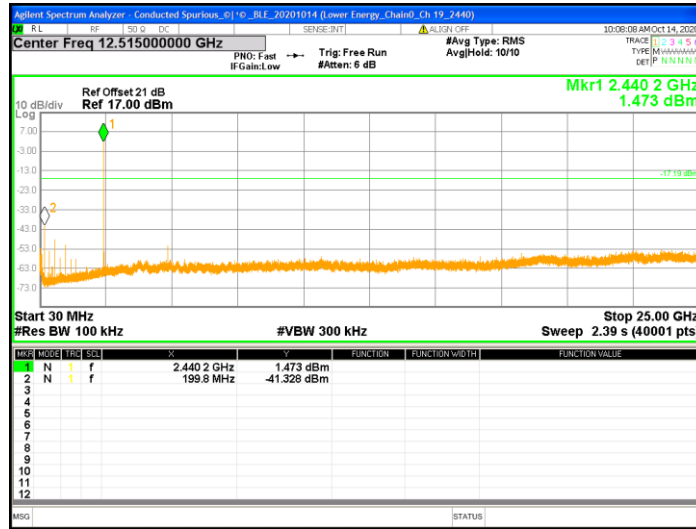

### Chain 0: Conducted Spurious @ Lower Energy Mode Ch 39

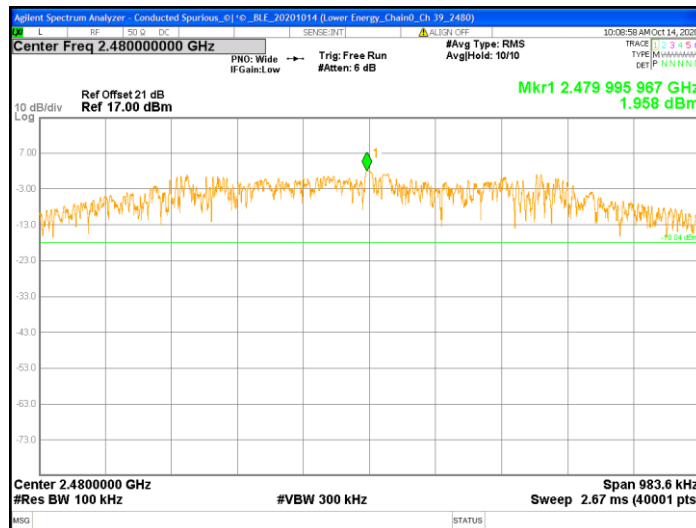

### Chain 0: Conducted Spurious @ Lower Energy Mode Ch 39

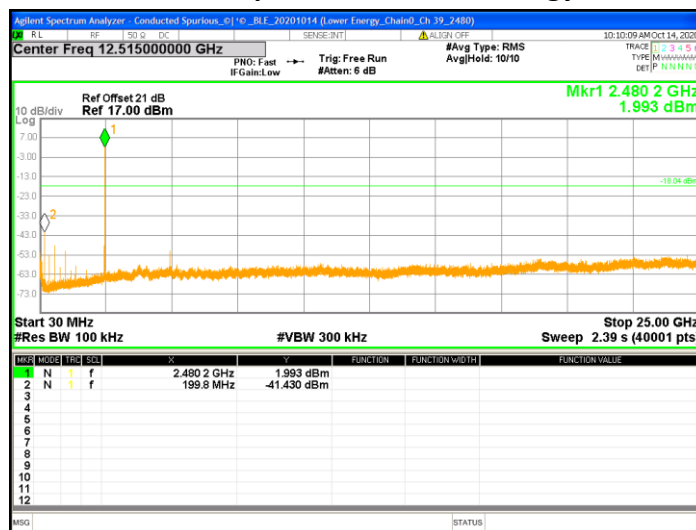

### Chain 0: Authorized Band Bandedge @ BLE Mode Ch0

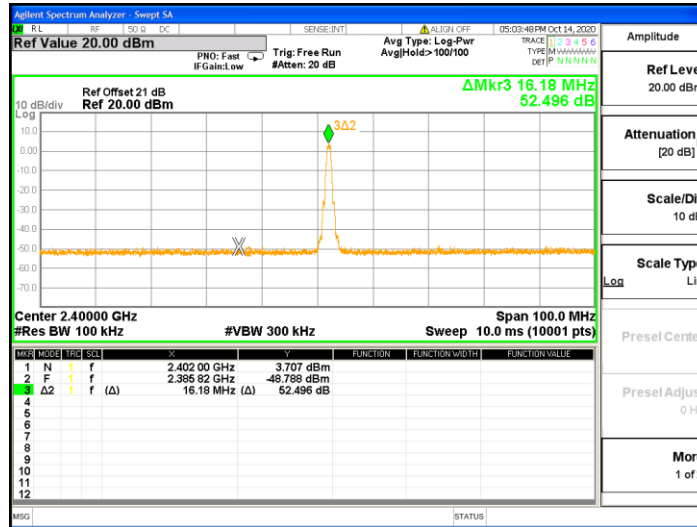

### Chain 0: Authorized Band Bandedge @ BLE Mode Ch39

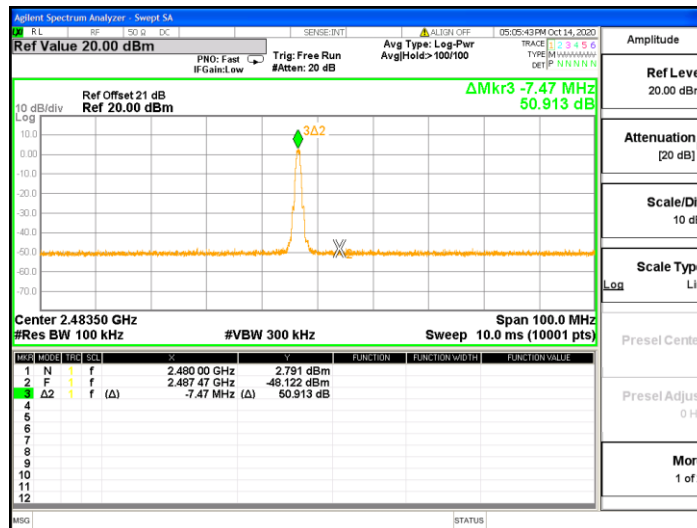

## 6. Emissions in Restricted Frequency Bands (Radiated emission measurements)

### 6.1 Instrument Setting

Receiver Function	Setting (Below 1GHz)	Setting (Above 1GHz)
Detector	QP	Peak and Average
RBW	9-150 kHz ; 200-300 Hz 0.15-30 MHz; 9-10 kHz 30-1000 MHz; 100-120 kHz	1MHz
VBW	$\geq 3 \times \text{RBW}$	3MHz
Sweep	Auto couple	Auto couple
Start Frequency	9 kHz	1GHz
Stop Frequency	1 GHz	Tenth harmonic
Attenuation	Auto	Auto

### 6.2 Test Procedure

Step 1	Configure the EUT according to ANSI C63.10:2013. The EUT was placed on the top of the turntable 0.8 meter (below 1GHz) and 1.5 meter (above 1GHz) above ground. The center of the receiving antenna mounted on the top of a height-variable antenna tower was placed 3 meters far away from the turntable.
Step 2	Power on the EUT and all the companion devices. The turntable was rotated by 360 degree to find the position of the maximum emission level.
Step 3	The height of the receiving antenna was varied between one meter and four meters above ground to find the maximum emission field strength of the both horizontal and vertical polarization.
Step 4	If find the frequencies above the limit or below within 3dB, the antenna tower was scan (from 1m to 4m) and then the turntable was rotated to find the maximum reading.
Step 5	Set the test-receiver system to peak or CISPR quasi-peak detector with specified bandwidth under maximum hold mode.
Step 6	For emissions above 1GHz, use 1MHz VBW and 3MHz RBW for reading in spectrum analyzer. Place the measurement antenna away from each area of the EUT determined to be a source of emissions at the specified measurement distance, while keeping the measurement antenna aimed at the source of emissions at each frequency of significant emissions, with polarization oriented for maximum response.
Step 7	If the emissions level of the EUT in peak mode was 3dB lower than the average limit specified then testing will be stopped and peak values of the EUT will be reported. Otherwise, the emissions which do not have 3dB margin will be measured using the quasi-peak method for below 1GHz.
Step 8	For testing above 1GHz, The emissions level of the EUT in peak mode was lower than average limit, then testing will be stopped and peak values of the EUT will be reported, otherwise, the emission will be measured in average mode again and reported.
Step 9	In case the emission is lower than 30MHz, loop antenna has to be used for measurement and the recorded data should be quasi-peak measured by receiver.

## 6.3 Test Diagram

### 6.3.1 Radiated emission from 9kHz to 30MHz uses Loop Antenna:

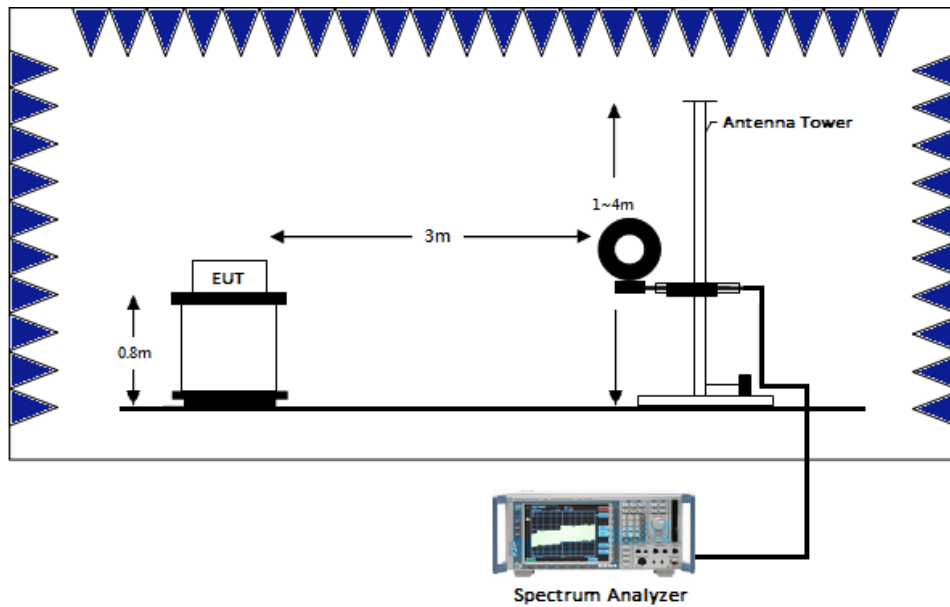

### 6.3.2 Radiated emission below 1GHz using Bilog Antenna

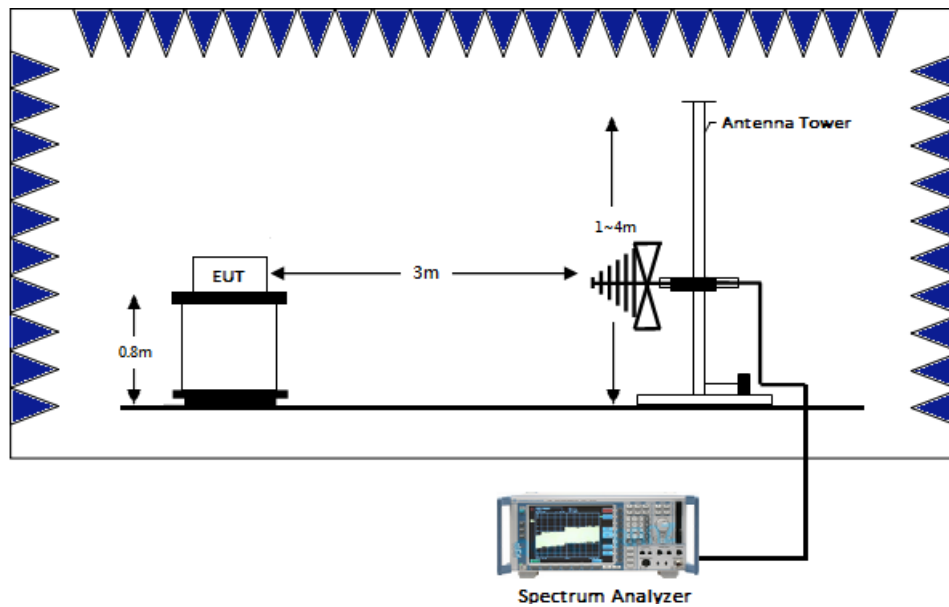

### 6.3.3 Radiated emission above 1GHz using Horn Antenna

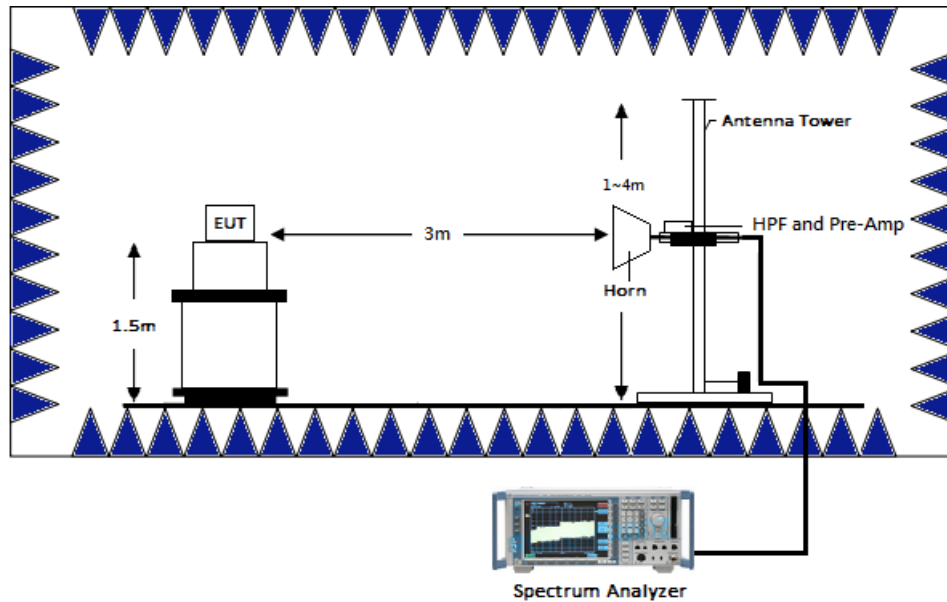

### 6.4 Limit

Frequency(MHz)	Field Strength(uV/m)	Measurement distance(m)
0.009~0.490	2400/F(kHz)	300
0.490~1.705	24000/F(kHz)	30
1.705~30	30	30
30-88	100	3
88-216	150	3
216-960	200	3
Above 960	500	3

Remark:

1. In the above table, the tighter limit applies at the band edges.
2. Distance refers to the distance in meters between the measuring instrument antenna and the closed point of any part of the device or system

### 6.5 Operating Environment Condition

Temperature (°C) :	25
Relative Humidity (%) :	56

## 6.6 Test Result

### 6.6.1 Measurement results: frequencies 9kHz to 30MHz

The test was performed on EUT under continuously transmitting mode. The worst case occurred at Channel 0.

Ant Polarity	Frequency (MHz)	Detector	Factor (dB/m)	Reading (dB $\mu$ V)	Corrected Reading (dB $\mu$ V/m)	Limit @ 3m (dB $\mu$ V/m)	Margin (dB)
Perpendicular	0.07	AV	18.36	35.23	53.59	110.70	-57.11
Perpendicular	0.13	AV	17.91	35.82	53.73	105.33	-51.60
Perpendicular	0.19	AV	18.13	32.82	50.95	102.03	-51.08
Perpendicular	0.25	AV	18.34	27.40	45.74	99.65	-53.91
Perpendicular	0.31	AV	18.52	24.66	43.18	97.78	-54.60
Perpendicular	0.37	AV	18.49	21.36	39.85	96.24	-56.39

Remark: Corr. Factor = Antenna Factor + Cable Loss

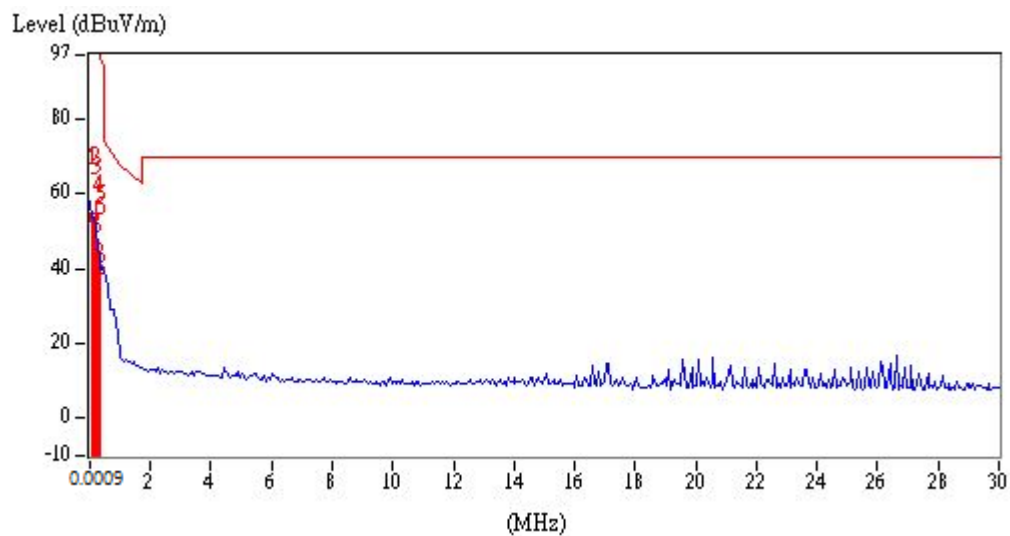



## TEST REPORT

Ant Polarity	Frequency (MHz)	Detector	Factor (dB/m)	Reading (dB $\mu$ V)	Corrected Reading (dB $\mu$ V/m)	Limit @ 3m (dB $\mu$ V/m)	Margin (dB)
Parallel	0.07	AV	18.36	34.48	52.84	110.70	-57.86
Parallel	0.13	AV	17.91	36.09	54.00	105.33	-51.33
Parallel	0.19	AV	18.13	32.95	51.08	102.03	-50.95
Parallel	0.25	AV	18.34	26.74	45.08	99.65	-54.57
Parallel	0.31	AV	18.52	24.95	43.47	97.78	-54.31
Parallel	0.37	AV	18.49	20.50	38.99	96.24	-57.25

Remark: Corr. Factor = Antenna Factor + Cable Loss

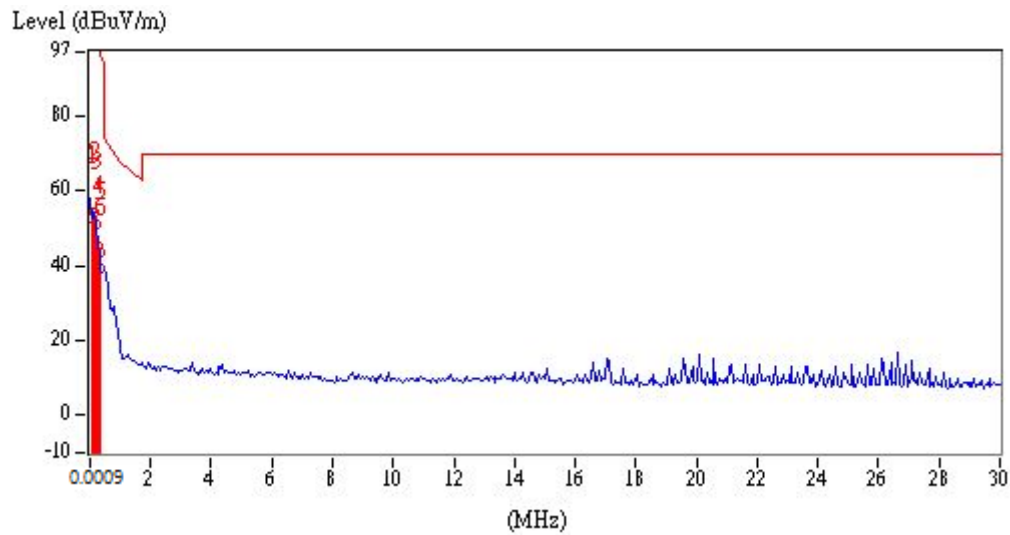

Ant Polarity	Frequency (MHz)	Detector	Factor (dB/m)	Reading (dB $\mu$ V)	Corrected Reading (dB $\mu$ V/m)	Limit @ 3m (dB $\mu$ V/m)	Margin (dB)
Ground-parallel	0.07	AV	18.36	35.34	53.70	110.70	-57.00
Ground-parallel	0.13	AV	17.91	35.95	53.86	105.33	-51.47
Ground-parallel	0.19	AV	18.13	32.62	50.75	102.03	-51.28
Ground-parallel	0.25	AV	18.34	26.88	45.22	99.65	-54.43
Ground-parallel	0.31	AV	18.52	26.72	45.24	97.78	-52.54
Ground-parallel	0.37	AV	18.49	21.02	39.51	96.24	-56.73

Remark: Corr. Factor = Antenna Factor + Cable Loss

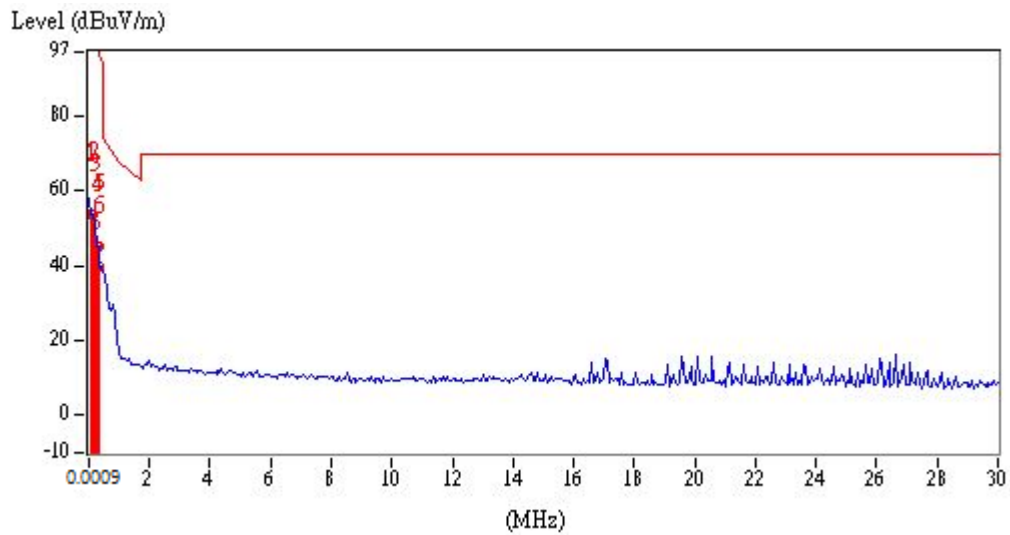

## TEST REPORT

### 6.6.1 Measurement results: frequencies below 1 GHz

The test was performed on EUT under continuously transmitting mode. The worst case occurred at Channel 0.

Ant Polarity	Frequency (MHz)	Detector	Factor (dB/m)	Reading (dB $\mu$ V)	Corrected Reading (dB $\mu$ V/m)	Limit @ 3m (dB $\mu$ V/m)	Margin (dB)
Vertical	30.00	QP	20.75	16.11	36.86	40.00	-3.14
Vertical	41.64	QP	21.46	8.62	30.08	40.00	-9.92
Vertical	70.74	QP	19.46	13.62	33.08	40.00	-6.92
Vertical	111.48	QP	18.45	7.03	25.48	43.50	-18.02
Vertical	165.80	QP	21.71	6.65	28.36	43.50	-15.14
Vertical	724.52	QP	31.56	3.73	35.29	46.00	-10.71

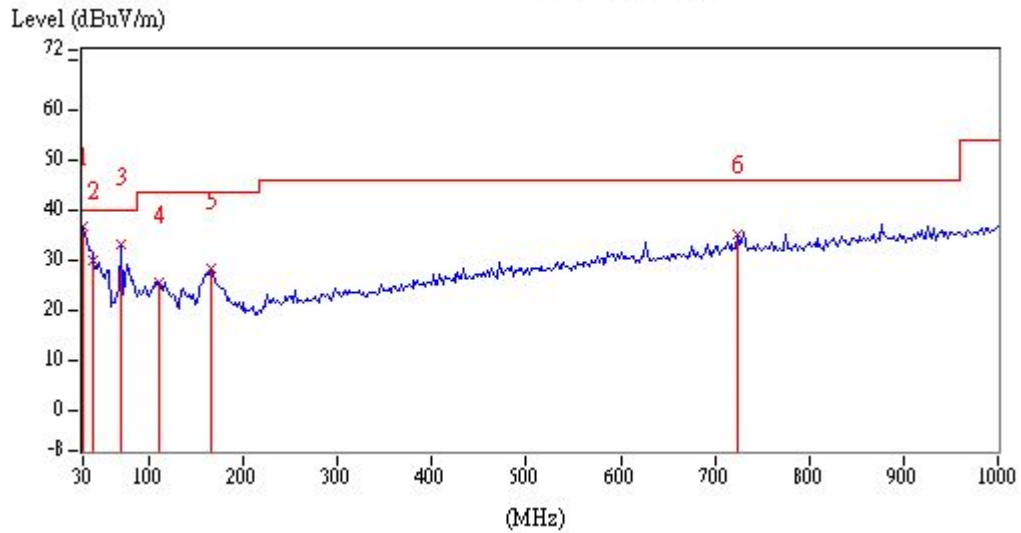

## TEST REPORT

Ant Polarity	Frequency (MHz)	Detector	Factor (dB/m)	Reading (dB $\mu$ V)	Corrected Reading (dB $\mu$ V/m)	Limit @ 3m (dB $\mu$ V/m)	Margin (dB)
Horizontal	33.88	QP	20.76	13.82	34.58	40.00	-5.42
Horizontal	49.40	QP	22.05	6.66	28.71	40.00	-11.29
Horizontal	70.74	QP	19.46	13.94	33.40	40.00	-6.60
Horizontal	76.56	QP	18.29	12.67	30.96	40.00	-9.04
Horizontal	103.72	QP	17.34	7.74	25.08	43.50	-18.42
Horizontal	169.68	QP	21.55	5.69	27.24	43.50	-16.26

Remark: Corr. Factor = Antenna Factor + Cable Loss

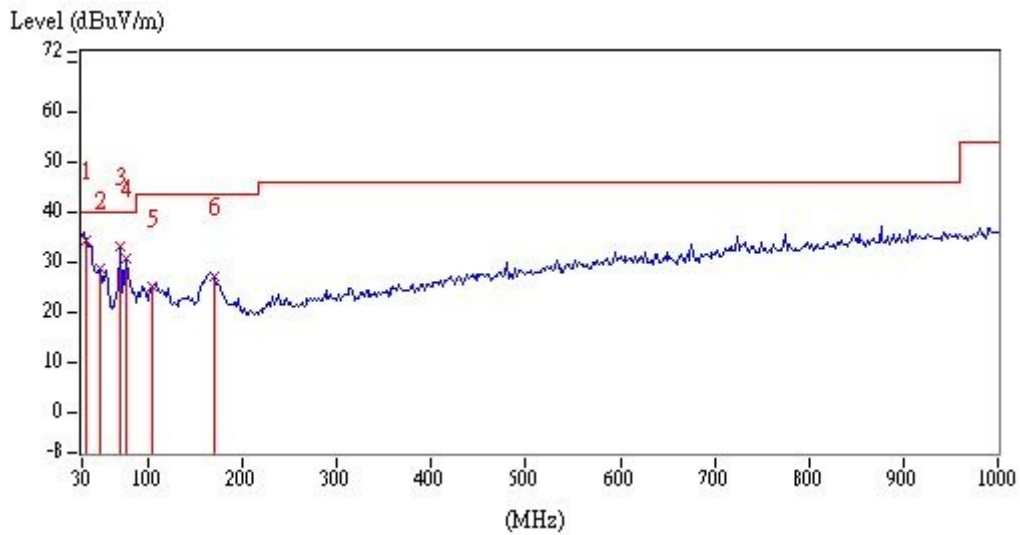

**TEST REPORT**

**6.6.2 Measurement results: frequency above 1GHz to 25GHz**

Mode	Frequency (MHz)	Spectrum Analyzer Detector	Ant. Pol. (H/V)	Correction Factor (dB/m)	Reading (dBμV)	Corrected Reading (dBμV/m)	Limit @ 3 m (dBμV/m)	Margin (dB)
BLE, Ch0	4804	PK	V	7.47	35.01	42.48	74	-31.52
	4988	PK	V	7.72	40.80	48.52	74	-25.48
	4804	PK	H	7.47	36.57	44.04	74	-29.96
	4988	PK	H	7.72	37.15	44.87	74	-29.13
BLE, Ch19	4884	PK	V	7.58	37.07	44.65	74	-29.35
	4988	PK	V	7.72	42.27	49.99	74	-24.01
	4884	PK	H	7.58	36.17	43.75	74	-30.25
	4988	PK	H	7.72	36.67	44.39	74	-29.61
BLE, Ch39	4960	PK	V	7.68	39.68	47.36	74	-26.64
	4988	PK	V	7.72	42.05	49.77	74	-24.23
	4960	PK	H	7.68	36.14	43.82	74	-30.18
	4988	PK	H	7.72	36.39	44.11	74	-29.89

Remark: Correction Factor = Antenna Factor + Cable Loss + High Pass Filter Loss - Pre\_Amplifier Gain

**7. Emission on Band Edge****7.1 Instrument Setting**

<b>Spectrum Function</b>	<b>Setting</b>
Detector	Peak and Average
RBW	1MHz
VBW	3MHz
Sweep	Auto couple
Restrict bands	2310 MHz ~ 2390 MHz 2483.5 MHz ~ 2500 MHz
Attenuation	Auto

**7.2 Test Procedure**

The test procedure is the same as Emissions in Restricted Frequency Bands (Radiated emission measurements).

**7.3 Operating Environment Condition**

Temperature (°C) :	25
Relative Humidity (%) :	56

7.4 Test Results

Mode	Frequency (MHz)	Spectrum Analyzer Detector	Ant. Pol. (H/V)	Correction Factor (dB/m)	Reading (dBμV)	Corrected Reading (dBμV/m)	Limit @ 3 m (dBμV/m)	Margin (dB)	Restricted band (MHz)
BLE	2388.68	PK	V	34.86	18.26	53.12	74	-20.88	2310~2390
	2382.80	AV	V	34.83	8.29	43.12	54	-10.88	
	2488.12	PK	V	35.32	19.77	55.09	74	-18.91	2483.5~2500
	2499.88	AV	V	35.37	8.68	44.06	54	-9.94	

Remark: Correction Factor = Antenna Factor + Cable Loss

### Chain 0: Restricted Band Bandedge @ BLE Mode Ch0 PK

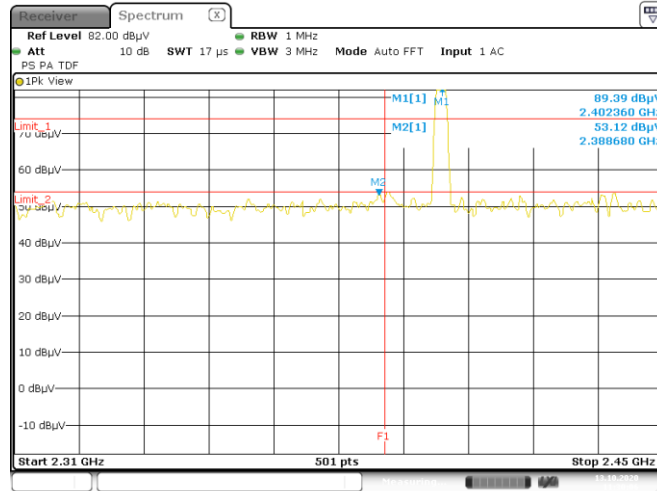

Date: 13.OCT.2020 11:30:06

### Chain 0: Restricted Band Bandedge @ BLE Mode Ch0 AV

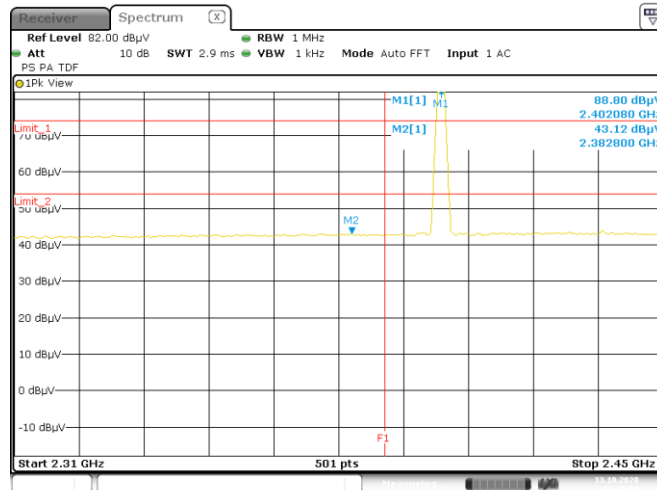

Date: 13.OCT.2020 11:30:00

### Chain 0: Restricted Band Bandedge @ BLE Mode Ch39 PK

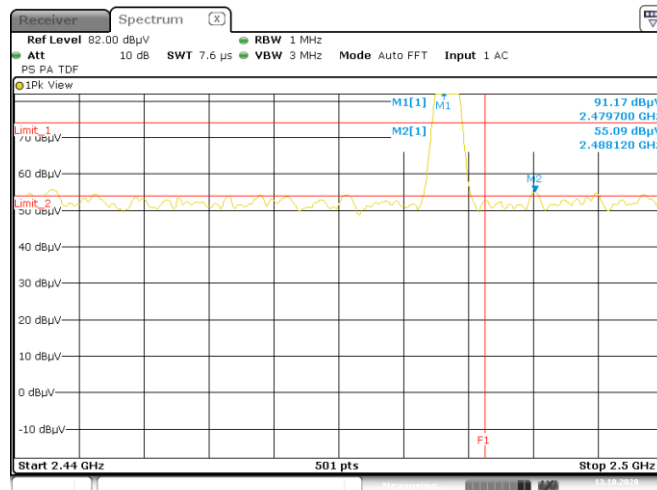

Date: 13.OCT.2020 11:43:22



### Chain 0: Restricted Band Bandedge @ BLE Mode Ch39 AV

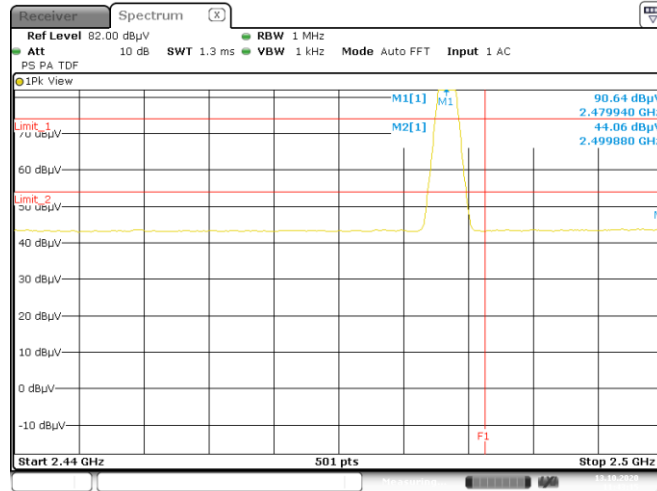

Date: 13.OCT.2020 11:43:16

## 8. AC Power Line Conducted Emission

### 8.1 Measuring instrument setting

Receiver Function	Setting
Detector	QP
Start frequency	0.15MHz
Stop frequency	30MHz
IF bandwidth	9 kHz
Attenuation	10dB

### 8.2 Test Procedure

Step 1	Configure the EUT according to ANSI C63.10:2013. The EUT or host of EHT has to be placed 0.4 meter far from the conducting wall of the shielding room and at least 80 centimeters from any other grounded conducting surface.
Step 2	Connect EUT or host of EUT to the power mains through a line impedance stabilization network.
Step 3	All the companion devices are connected to the other LISN. The LISN should provide 50Uh/50ohms coupling impedance.
Step 4	The frequency range from 150 kHz to 30MHz was searched.
Step 5	Set the test-receiver system to peak detector and specified bandwidth with maximum hold mode.
Step 6	The measurement has to be done between each power line and ground at the power terminal.

### 8.3 Test Diagram

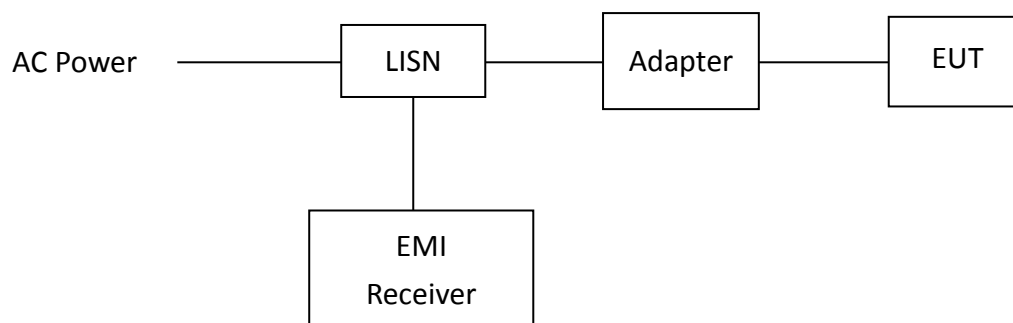

**8.4 Limit**

Frequency (MHz)	Conducted Limit (dBuV)	
	Q.P.	Ave.
0.15~0.50	66 – 56	56 – 46
0.50~5.00	56	46
5.00~30.0	60	50

**8.5 Operating Environment Condition**

Temperature (°C) :	25
Relative Humidity (%) :	56
Atmospheric Pressure (hPa) :	1007

## 8.6 Test Results

Phase: Live Line  
 Model No.: Milano XL  
 Test Condition: Tx mode

Frequency (MHz)	Corr. Factor (dB)	Reading QP (dBuV)	Level QP (dBuV)	Limit QP (dBuV)	Reading AV (dBuV)	Level AV (dBuV)	Limit AV (dBuV)	Margin (dB)	
								QP	AV
0.253	9.72	28.83	38.55	61.64	27.93	37.65	51.64	-23.09	-13.99
0.449	9.78	21.02	30.80	56.89	8.11	17.89	46.89	-26.09	-29.00
0.486	9.79	19.40	29.19	56.23	11.26	21.05	46.23	-27.04	-25.18
0.579	9.80	16.93	26.72	56.00	7.59	17.39	46.00	-29.28	-28.61
4.292	9.88	21.79	31.66	56.00	19.31	29.19	46.00	-24.34	-16.81
29.841	10.85	33.87	44.72	60.00	33.25	44.10	50.00	-15.28	-5.90

Remark:

1. Corr. Factor (dB) = LISN Factor (dB) + Cable Loss (dB)
2. Level (dBuV) = Corr. Factor (dB) + Reading (dBuV)
3. Margin (dB) = Level (dBuV) – Limit (dBuV)

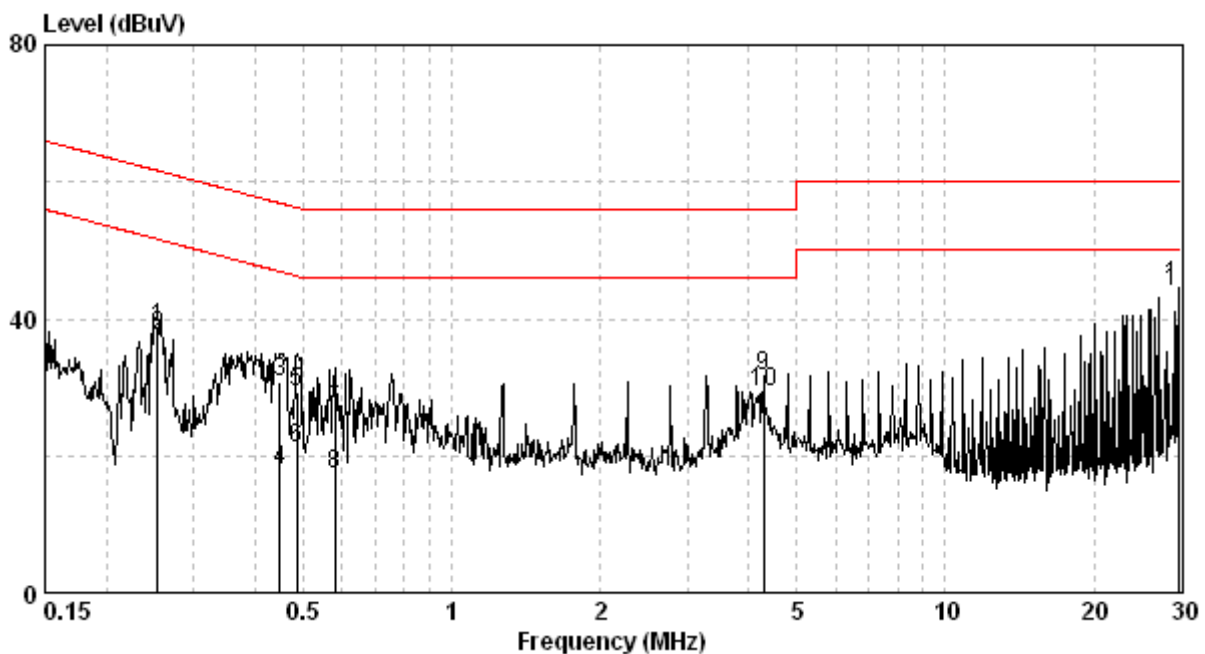

## TEST REPORT

Phase: Neutral Line  
 Model No.: Milano XL  
 Test Condition: Tx mode

Frequency (MHz)	Corr. Factor (dB)	Reading QP (dBuV)	Level QP (dBuV)	Limit QP (dBuV)	Reading AV (dBuV)	Level AV (dBuV)	Limit AV (dBuV)	Margin (dB)	
								QP	AV
0.252	9.71	29.51	39.22	61.68	28.57	38.28	51.68	-22.47	-13.41
0.483	9.79	18.26	28.05	56.29	9.52	19.31	46.29	-28.24	-26.98
0.567	9.79	17.71	27.50	56.00	10.77	20.56	46.00	-28.50	-25.44
0.755	9.80	19.69	29.48	56.00	17.91	27.70	46.00	-26.52	-18.30
4.292	9.87	16.77	26.64	56.00	10.72	20.59	46.00	-29.36	-25.41
30.000	10.99	33.12	44.11	60.00	32.24	43.23	50.00	-15.89	-6.77

### Remark:

1. Corr. Factor (dB) = LISN Factor (dB) + Cable Loss (dB)
2. Level (dBuV) = Corr. Factor (dB) + Reading (dBuV)
3. Margin (dB) = Level (dBuV) – Limit (dBuV)

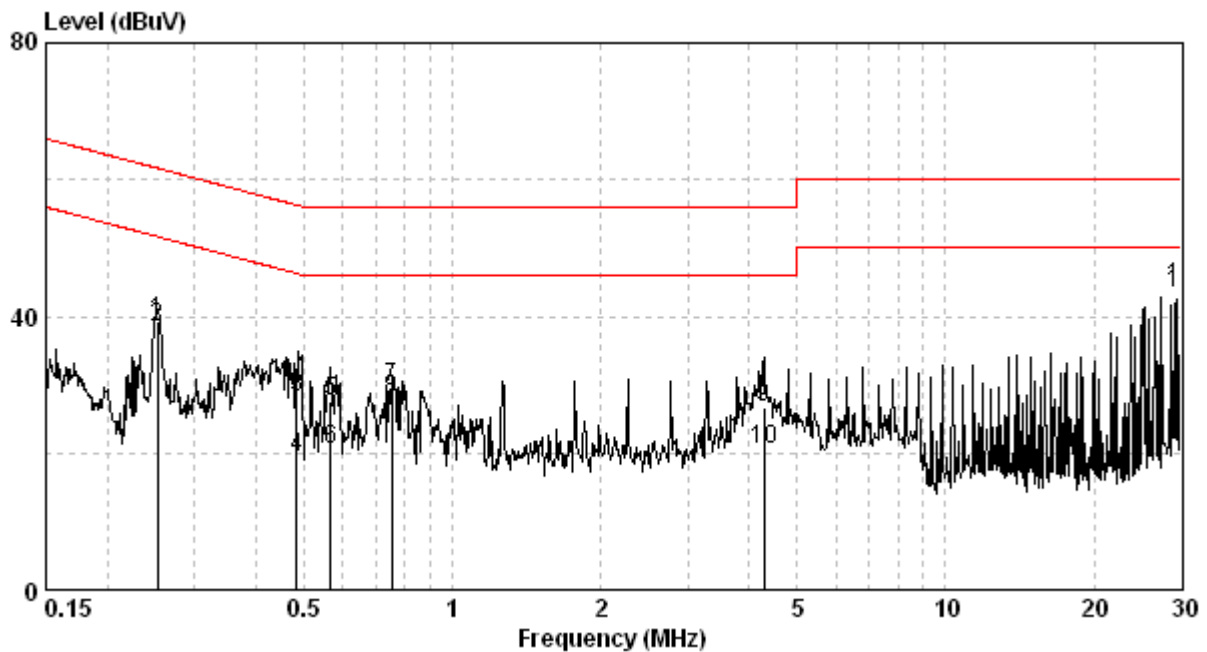

**Appendix A: Test equipment list**

Test Equipment/ Test site	Brand	Model No.	Serial No.	Calibration Date	Next Calibration Date
EMI Test Receiver	Rohde & Schwarz	ESR-7	101232	2020/01/18	2021/01/16
Spectrum Analyzer	R&S	FSP30	100137	2020/08/25	2021/08/24
Signal Analyzer	Agilent	N9030A	MY51380492	2020/08/17	2021/08/16
Active Loop Antenna	SCHWARZBECK MESS-ELEKTRONIC	FMZB1519	1519-067	2020/04/13	2021/04/12
Broadband Antenna	SHWARZBECK	VULB 9168	9168-172	2020/06/02	2021/06/01
Horn Antenna	SHWARZBECK	BBHA 9120 D	9120D-456	2020/01/20	2021/01/18
Horn Antenna	SCHWARZBECK	BBHA 9170	BBHA9170159	2020/08/20	2023/08/19
Pre-Amplifier	SCHWARZBECK	BBV9718	9718-004	2019/10/16	2020/10/14
Pre-Amplifier	SCHWARZBECK	BBV9718	9718-004	2020/10/15	2021/10/14
Pre-Amplifier	EMCI	EMC184045SE	980512	2020/06/01	2021/05/31
RF Cable	SUHNER	SUCOFLEX 102	CB0006	2020/04/30	2021/04/29
Hight Pass Filter	Reactel	7HS-3G/18G-S11	N/A	2020/05/27	2021/05/26
966-2(A) Cable	SUHNER	SMA / EX 100	N/A	2020/08/17	2021/08/16
966-2(B) Cable	SUHNER	SUCOFLEX 104P	CB0005	2020/08/17	2021/08/16
Power Meter	Anritsu	ML2495A	0844001	2019/10/23	2020/10/21
Power Sensor	Anritsu	MA2411B	0738452	2019/10/23	2020/10/21
966-2_3m Semi-Anechoic Chamber	966_2	CEM-966_2	N/A	2020/02/23	2021/02/22
EMI Test Receiver	R&S	ESCI	100059	2019/11/05	2020/11/03
LISN	R&S	ENV216	101160	2020/07/17	2021/07/16
CON-2 Cable	SUHNER	EMCCFD300-BM -NM-6000	170502	2020/04/30	2021/04/29
Test software	Audix	e3	V4.20040112L	NCR	NCR

Note: No Calibration Required (NCR).

**Appendix B: Measurement Uncertainty**

This uncertainty represents an expanded uncertainty expressed at approximately the 95 % confidence level using a coverage factor of k=2.

Item	Uncertainty
Vertically polarized radiated disturbances from 30MHz~1GHz in a semi-anechoic chamber at a distance of 3m	5.10 dB
Horizontally polarized radiated disturbances from 30MHz~1GHz in a semi-anechoic chamber at a distance of 3m	5.19 dB
Vertically polarized Radiated disturbances from 1GHz~18GHz in a semi-anechoic chamber at a distance of 3m	4.29 dB
Horizontally polarized Radiated disturbances from 1GHz~18GHz in a semi-anechoic chamber at a distance of 3m	4.29 dB
Vertically polarized Radiated disturbances from 18GHz~26.5GHz in a semi-anechoic chamber at a distance of 1m	2.45 dB
Horizontally polarized Radiated disturbances from 18GHz~26.5GHz in a semi-anechoic chamber at a distance of 1m	2.45 dB
Radiated disturbances from 9kHz~30MHz in a semi-anechoic chamber at a distance of 3m	3.32 dB
Emission on the Band Edge Test	4.29 dB
Minimum 6 dB Bandwidth	7.69 %
Maximum Peak Conducted Output Power	0.37 dB
Power Spectral Density	1.15 dB
Emissions In Non-Restricted Frequency Bands	1.15 dB
AC Power Line Conducted Emission	2.52 dB