



Produkte
Products

Prüfbericht - Nr.: 50036571 001		Seite 1 von 114 Page 1 of 114	
<i>Test Report No.:</i>			
Auftraggeber: <i>Client:</i>	Kpnetworks Ltd. 4-5-11 10F Shiba Minato-ku, Tokyo 108-0014, Japan		
Gegenstand der Prüfung: <i>Test Item:</i>	Gateway Board		
Bezeichnung: <i>Identification:</i>	ISH-1101-003	Serien-Nr.: <i>Serial No.:</i>	001, 002
Wareneingangs-Nr.: <i>Receipt No.:</i>	A000310587	Eingangsdatum: <i>Date of Receipt:</i>	2016-01-12
Zustand des Prüfgegenstandes bei Anlieferung: Good <i>Condition of Test Item at Delivery:</i>			
Prüfört: <i>Testing Location:</i>	TÜV Rheinland Japan Ltd. – Global Technology Assessment Center 4-25-2 Kita-Yamata, Tsuzuki-ku, Yokohama 224-0021, Japan		
Prüfgrundlage: <i>Test Specification:</i>	FCC 47 CFR Part 15, Subpart C, Section 15.247 (October 1, 2015) RSS-247 (Issue 1): 2015 RSS-Gen (Issue 4): 2014 ANSI C63.10-2013 KDB Publication No. 558074 D01: Guidance for Performing Compliance Measurements on Digital Transmission Systems (DTS) Operating Under §15.247 (v03r04)		
Prüfergebnis: <i>Test Result:</i>	Der Prüfgegenstand entspricht oben genannter Prüfgrundlage(n). <i>The test item passed the test specification(s).</i>		
Prüflaboratorium: <i>Testing Laboratory:</i>	TÜV Rheinland Japan Ltd. – Global Technology Assessment Center 4-25-2 Kita-Yamata, Tsuzuki-ku, Yokohama 224-0021, Japan		
geprüft/ tested by:		kontrolliert/ reviewed by:	
			
2016-03-10	A. Abe / Inspector	2016-03-10	R. Meiranke / Reviewer
Datum <i>Date</i>	Name/Stellung <i>Name/Position</i>	Unterschrift <i>Signature</i>	Datum <i>Date</i>
			Name/Stellung <i>Name/Position</i>
			Unterschrift <i>Signature</i>
Sonstiges / Other Aspects:			
This test report covers only aspects related to 2.4GHz wireless LAN function of the EUT.			
Abkürzungen:	P(ass) = entspricht Prüfgrundlage	Abbreviations:	P(ass) = passed
	F(ail) = entspricht nicht Prüfgrundlage		F(ail) = failed
	N/A = nicht anwendbar		N/A = not applicable
	N/T = nicht getestet		N/T = not tested
<p>Dieser Prüfbericht bezieht sich nur auf das o.g. Prüfmuster und darf ohne Genehmigung der Prüfstelle nicht auszugsweise vervielfältigt werden. Dieser Bericht berechtigt nicht zur Verwendung eines Prüfzeichens. <i>This test report relates to the a. m. test sample. Without permission of the test center this test report is not permitted to be duplicated in extracts. This test report does not entitle to carry any safety mark on this or similar products.</i></p>			

TEST SUMMARY

5.1.1 SUPPLY VOLTAGE REQUIREMENTS

RESULT: PASS

5.1.2 ANTENNA REQUIREMENTS

RESULT: PASS

5.1.3 RESTRICTED BANDS OF OPERATION

RESULT: PASS

5.2.1 CONDUCTED OUTPUT POWER

RESULT: PASS

5.2.2 6dB BANDWIDTH

RESULT: PASS

5.2.3 99% BANDWIDTH

5.2.4 CONDUCTED SPURIOUS EMISSIONS

RESULT: PASS

5.2.5 PEAK POWER SPECTRAL DENSITY

RESULT: PASS

5.3.1 RADIATED SPURIOUS EMISSIONS OF TRANSMITTER

RESULT: PASS

5.4.1 AC POWER LINE CONDUCTED EMISSION OF TRANSMITTER

RESULT: PASS

Contents

1.	GENERAL REMARKS	5
1.1	COMPLEMENTARY MATERIALS	5
2.	TEST SITES	5
2.1	TEST FACILITIES	5
2.2	LIST OF TEST AND MEASUREMENT INSTRUMENTS	6
2.3	MEASUREMENT UNCERTAINTY	7
3.	GENERAL PRODUCT INFORMATION	8
3.1	PRODUCT FUNCTION AND INTENDED USE	8
3.2	SYSTEM DETAILS	8
3.3	CLOCK FREQUENCIES	9
3.4	NOISE SUPPRESSING PARTS	9
4.	TEST SET-UP AND OPERATION MODES	10
4.1	TEST METHODOLOGY	10
4.2	OPERATION MODES	10
4.3	PHYSICAL CONFIGURATION FOR TESTING	10
4.4	TEST SOFTWARE	12
4.5	SPECIAL ACCESSORIES AND AUXILIARY EQUIPMENT	13
4.6	COUNTERMEASURES TO ACHIEVE COMPLIANCE	14
5.	TEST RESULTS RADIO	15
5.1	TECHNICAL REQUIREMENTS	15
5.1.1	<i>Supply Voltage Requirements</i>	<i>15</i>
5.1.2	<i>Antenna Requirements</i>	<i>15</i>
5.1.3	<i>Restricted Bands of Operation</i>	<i>16</i>
5.2	CONDUCTED MEASUREMENTS AT ANTENNA PORT	17
5.2.1	<i>Conducted Output Power</i>	<i>17</i>
5.2.2	<i>6dB Bandwidth</i>	<i>22</i>
5.2.3	<i>99% Bandwidth</i>	<i>31</i>
5.2.4	<i>Conducted Spurious Emissions</i>	<i>40</i>
5.2.5	<i>Peak Power Spectral Density</i>	<i>77</i>
5.3	RADIATED MEASUREMENTS	86
5.3.1	<i>Radiated Spurious Emissions of Transmitter</i>	<i>86</i>
5.4	AC POWER LINE CONDUCTED MEASUREMENTS	105
5.4.1	<i>AC Power Line Conducted Emission of Transmitter</i>	<i>105</i>
6.	PHOTOGRAPHS OF THE TEST SETUP	107

Produkte
Products

Prüfbericht - Nr.: 50036571 001
Test Report No.:

Seite 4 von 114
Page 4 of 114

7.	LIST OF TABLES.....	111
8.	LIST OF FIGURES	112
9.	LIST OF PHOTOGRAPHS.....	114

1. General Remarks

1.1 Complementary Materials

There is no attachment to this test report.

2. Test Sites

2.1 Test Facilities

TÜV Rheinland Japan Ltd. – Global Technology Assessment Center
4-25-2 Kita-Yamata, Tsuzuki-ku, Yokohama 224-0021, Japan

The used test equipment is in accordance with CISPR 16 for measurement of radio interference.

The Federal Communications Commission has reviewed the technical characteristics of the radiated and conducted emission facilities and has found these test sites to be in compliance with the requirements of section 2.948 of the FCC rules. The description of the test facility is listed under FCC registration number 299054.

The Industry Canada has reviewed the technical characteristics of the radiated and conducted emission facilities and has found these test sites to be in compliance with Canadian requirements. The description of the test facility is listed under OATS filing number 3466B-1.

The test facility is accredited by VLAC (member of ILAC) under number VLAC-017 according to ISO/IEC 17025:2005.



TÜV Rheinland Japan Ltd. is accredited by the Federal Communications Commission as a Conformity Assessment Body under Designation Number JP0017 and Test Firm Registration Number 386498.

2.2 List of Test and Measurement Instruments

Table 1: List of Test and Measurement Equipment

Kind of Equipment	Manufacturer	Model Name	Serial Number	Equipment ID	Calibrated until
For Antenna Port Conducted Emission					
Receiver	Rohde & Schwarz	ESU 40	100029	RF-0021	2016-03
RF Power Meter	Agilent	N1911A	MY451017 37	RF-0393	2016-10
RF Peak Power Sensor	Agilent	N1921A	MY452422 28	RF-0394	2016-10
For AC Power Line Conducted Emission					
Conducted Emission Measurement Software	Toyo Corporation	EP5/CE	Ver. 5.0.20	RF-0025	2016-01
Receiver	Rohde & Schwarz	ESU 40	100029	RF-0021	2016-03
LISN	Rohde & Schwarz	ENV216	100276	RF-0016	2016-05
LISN	Rohde & Schwarz	ENV216	101958	RF-0708	2016-09
For Radiated Emission					
Radiated Emission Measurement Software (below 30MHz)	Toyo Corporation	EP5/ME	Ver. 5.0.10	RF-0172	2017-02
Radiated Emission Measurement Software (above 30MHz)	Toyo Corporation	EP7/RE	Ver. 5.0.2	RF-0026	2017-02
Receiver	Rohde & Schwarz	ESU 8	100025	RF-0020	2016-08
Receiver	Rohde & Schwarz	ESU 40	100029	RF-0021	2016-03
RF Selector (10m Chamber)	Toyo Corporation	NS4900	0703-182	RF-0029	2017-02
Loop Antenna with Amplifier, 9kHz-30MHz	Rohde & Schwarz	HFH2-Z2	100139	RF-0048	2016-05
Trilog Antenna No. 2, 30-1000MHz	Schwarzbeck	VULB9168	9168-475	RF-0462	2016-10
Biconical Antenna, 30-300MHz	EMCO	3110B	9603-2379	RF-0207	2016-08
10dB Attenuator	Hewlett Packard	8491A 10dB	58354	RF-0314	2017-01
Low Noise Preamplifier, 9kHz-1GHz	TSJ	MLA-10K01-B01-35	1370750	RF-0253	2017-02
Low Pass Filter, DC-1GHz	R&K	LP1000CH3	12104001	RF-0515	2017-02
Horn Antenna, 1-8GHz	Schwarzbeck	BBHA9120D	1059	RF-0553	2016-06
Microwave Preamplifier, 1-8GHz	Toyo Corporation	TPA0108-40	0634	RF-0052	2017-02
Band Reject Filter, 1-8GHz	Nitsuki	NF-49BT	027	RF-0131	2017-02
Horn Antenna with Preamplifier, 8-18GHz	Toyo Corporation	HAP06-18W	00000025	RF-0065	2016-07

Produkte
 Products

Prüfbericht - Nr.: 50036571 001

Seite 7 von 114

Test Report No.:

Page 7 of 114

Kind of Equipment	Manufacturer	Model Name	Serial Number	Equipment ID	Calibrated until
High Pass Filter, 8-18GHz	Micro-Tronics	HPM50107	006	RF-0334	2016-07
Horn Antenna with Preamplifier, 18-26.5GHz	Toyo Corporation	HAP18-26N	00000010	RF-0070	2016-07
Constant Voltage Constant Frequency Stabilizers and Power Accessories					
CVCF (Shielded Room)	NF Corporation	ES2000S	9075612	RF-0210	N/A
CVCF Booster (Shielded Room)	NF Corporation	ES2000B	9074403	RF-0211	N/A
CVCF (10m Chamber)	NF Corporation	ES2000U	9067307	RF-0212	N/A
CVCF Booster (10m Chamber)	NF Corporation	ES2000B	9074408	RF-0213	N/A
True RMS Multimeter	Fluke	87V	97680445	RF-0281	2017-02

Conformance of the used measurement and test equipment with the requirements of ISO/IEC 17025:2005 has been confirmed before testing.

2.3 Measurement Uncertainty

Table 2: Emission Measurement Uncertainty

Measurement Type	Frequency	Uncertainty
AC Power Line Conducted Emission	150kHz - 30MHz	±2.0dB
Antenna Port Conducted Emission	20Hz - 40GHz	±1.5dB
Radiated Emission	150kHz - 30MHz	±4.7dB
	30MHz - 1GHz	±4.7dB
	> 1GHz	±4.7dB

3. General Product Information

3.1 Product Function and Intended Use

The EUT (Equipment Under Test) is a printed circuit board that has two types of unlicensed transmitters: 2.4GHz Wireless LAN and Bluetooth. In additions, the EUT incorporates one certified M2M module. Consequently, 3G communication and GPS receiving functions are also available. Since the EUT will be incorporated into other host equipment, the EUT does not have any enclosure (*). These hosts are used in an industrial environment such as monitoring system for photovoltaic panels at outdoor environment.

Note:

(*) The Wi-Fi and Bluetooth transmitters of this EUT do **not** have their own shielding.

3.2 System Details

Radio standard:	IEEE 802.11b, IEEE 802.11g, IEEE 802.11n (20HT/40HT)
Output power:	16.27dBm for IEEE 802.11b 19.27dBm for IEEE 802.11g 19.23dBm for IEEE 802.11n (20HT) 19.14dBm for IEEE 802.11n (40HT)
Antenna gain:	2.1dBi (*)
Antenna type:	Chip antenna
Antenna mounting type:	On board
Frequency range:	2412 - 2462MHz for IEEE 802.11b, 11g, 11n (20HT) 2422 - 2452MHz for IEEE 802.11n (40HT)
Number of channels:	11 for IEEE 802.11b, 11g, 11n (20HT) 7 for IEEE 802.11n (40HT)
Channel spacing:	5MHz
Modulation type:	DSSS coupled with DBPSK, DQPSK and CCK OFDM coupled with BPSK, QPSK, 16QAM and 64QAM
FCC classification:	DTS
IC classification:	Spread Spectrum/Digital Device (2400-2483.5 MHz)
Emission designator:	G1D
Rated voltage:	DC 5V
Rated current:	Maximum 2.15A
Protection class:	III
Test voltage:	AC 120V (representative AC/DC adapter)
Test frequency:	60Hz

Note:

(*) The chip antenna is shared by wireless LAN and Bluetooth communications. However, wireless LAN and Bluetooth do not transmit simultaneously by the specifications.

3.3 Clock Frequencies

The highest frequency generated or used by the EUT is 800MHz for the digital interface.

3.4 Noise Suppressing Parts

Refer to schematics.

4. Test Set-up and Operation Modes

4.1 Test Methodology

The test methodology used is based on the requirements of 47 CFR Part 15, Sections 15.31, 15.33, 15.35, 15.205, 15.207, 15.209 and KDB Publication No. 558074 D01.

The test methods, which have been used, are based on ANSI C63.10-2013 and RSS-Gen (Issue 4).

For details, see under each test item.

4.2 Operation Modes

Testing was performed at the lowest operating frequencies (2412MHz/2422MHz), at the operating frequency in the middle of the specified frequency band (2437MHz) and at the highest operating frequencies (2462MHz/2452MHz).

The basic operation modes used for testing are:

- A. EUT transmits (TX mode), with full power, at lowest channel (2412MHz/2422MHz^[*]), a continuous modulated signal streaming with maximum duty cycle.
- B. EUT transmits (TX mode), with full power, at middle channel (2437MHz), a continuous modulated signal streaming with maximum duty cycle.
- C. EUT transmits (TX mode), with full power, at highest channel (2462MHz/2452MHz^[*]), a continuous modulated signal streaming with maximum duty cycle.

Note: [*] for IEEE 802.11n (40HT) only

4.3 Physical Configuration for Testing

The test system was configured in a typical fashion (as a customer would normally use it).

The justification and manipulation of cables and equipment in order to simulate a worst-case behavior of the test setup has been carried out as prescribed in ANSI C63.10-2013.

Figure 1: Block Diagram

1) Test Setup of Conducted Radio testing

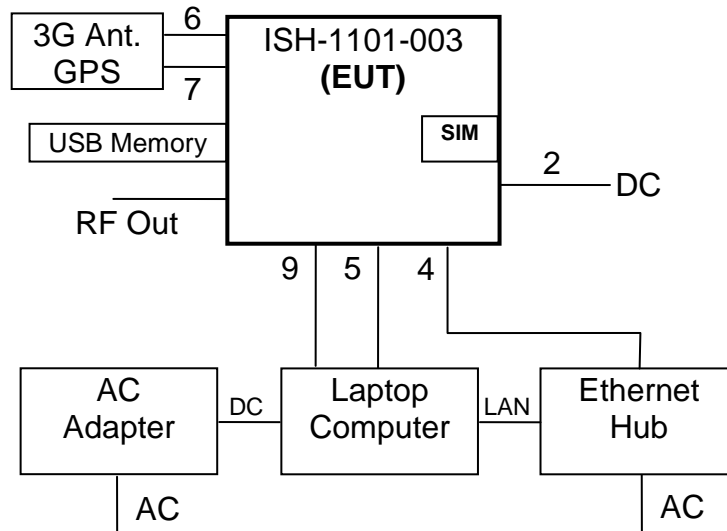

2) Test Setup of Radiated Radio testing

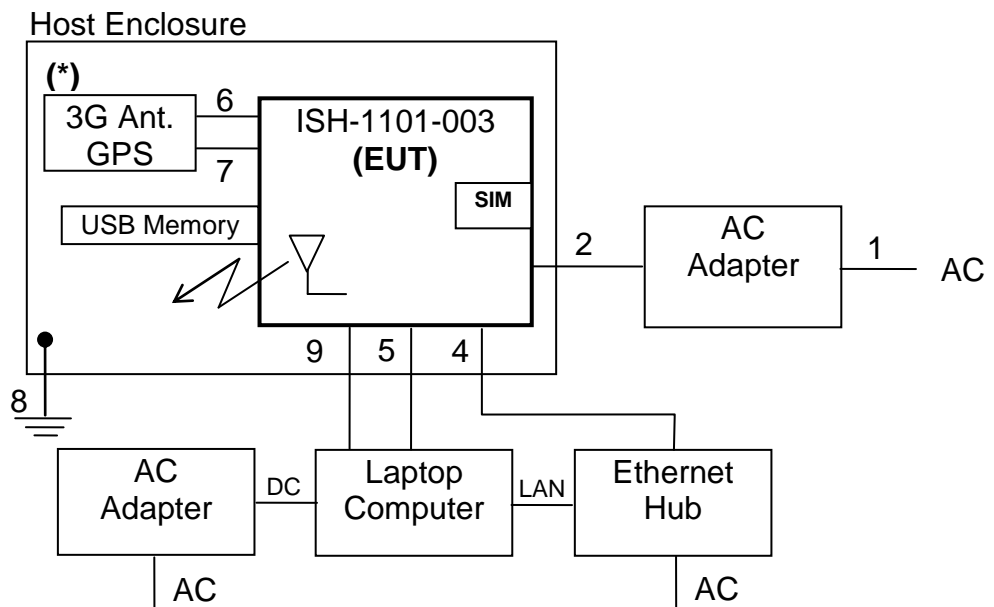

Note:

(*) Representative host enclosure was used for this test set up.

Table 3: Interfaces present on the EUT

No.	Interface	Cable Length for Testing, Shielding	Interface Classification
1.	AC Mains	1.8m, Un-shielded	AC Power Line
2.	DC Input	2m, Un-shielded	DC Power Line
3.	USB	Direct plug-in (**)	Signal and DC Power Line
4.	Ethernet (Cat. 5)	1.4m, Un-shielded	Telecommunication Line
5.	RS-485 #1	1.35m, Un-shielded	Signal Line
6.	3G Antenna	0.2m, Un-shielded	Signal Line
7.	GPS Antenna	0.2m, Un-shielded	Signal Line
8.	Frame Ground	1.4m, Un-shielded	Signal Line
9.	UART	2.2m, Un-shielded	Signal Line
10.	Digital I/O (*)	-/-	Signal Line
11.	Analog Input (*)	-/-	Signal Line
12.	RS-485 #2 (*)	-/-	Signal Line

Note:

(*) Interfaces Digital I/O, Analog Input and RS-485 #2 on the EUT are not used by the end user. Therefore, these ports were not connected during testing.

(**) USB I/F is specified as direct plugged-in type by the customer, no need extension cable for testing.

Two test samples were available. Sample No. 001 was used for antenna conducted measurements and sample No. 002 was used for AC power line conducted measurement and for radiated measurements.

For more details, refer to section: Photographs of the Test Set-Up.

4.4 Test Software

The EUT was provided by the manufacturer with suitable software to allow operation in all the required modes.

Software used for testing:

Tera Term version 4.89 by Tera Term project (to initiate Wireless LAN or Bluetooth mode)

Real Time Tuning Tool version 2.0.0.55 by EFC (to set up EUT mode when in Wireless LAN mode)

HCI Tester version 3.0.0.35 (to set up EUT mode when in Bluetooth mode)

These softwares were running on the laptop computer connected to the EUT. They were used to enable the test operation modes listed in section 4.2 as appropriate.

4.5 Special Accessories and Auxiliary Equipment

The product has been tested together with the following additional accessories:

1. Product: AC Adapter for EUT
Manufacturer: Unifive
Model: UI318-05
Rated Voltage: AC 100-240V
Input Current: 0.4A
Frequency: 50/60Hz
Protection Class: II
Serial Number: F02-0093765
2. Product: Laptop Computer
Manufacturer: Dell
Model: Latitude E6400
Rated Voltage: DC 19.5V
Protection Class: III
Serial Number: 39161719725
3. Product: AC Adaptor for Laptop Computer
Manufacturer: Dell
Model: FA90PE0-00
Rated Voltage: AC 100-240V
Input Current: 1.5A
Frequency: 50-60Hz
Protection Class: II
Serial Number: CN-0NY512-73245-919-2877-A00
4. Product: Ethernet Hub
Manufacturer: Allied Telesis
Model: Center COM GS908XL
Rated Voltage: AC 100-240V
Input Current: 0.2A
Frequency: 50/60Hz
Protection Class: I
Serial Number: 007613G125000804E1
5. Product: USB Memory
Manufacturer: Buffalo
Model: RUF2-K16GR F
Rated Voltage: DC 5V (USB Bus-powered)
Protection Class: III
Serial Number: I31001

4.6 Countermeasures to achieve Compliance

No additional measures were employed to achieve compliance.

5. Test Results RADIO

5.1 Technical Requirements

5.1.1 Supply Voltage Requirements

RESULT: **PASS**

Requirements:

FCC 15.31(e)

For intentional radiators, measurements of the variation of the input power or the radiated signal level of the fundamental frequency component of the emission, as appropriate, shall be performed with the supply voltage varied between 85% and 115% of the nominal rated supply voltage. For battery operated equipment, the equipment tests shall be performed using a new battery.

Verdict:

The EUT has an internal voltage regulator to supply the RF circuit. Hence it complies with the supply voltage requirements.

5.1.2 Antenna Requirements

RESULT: **PASS**

Requirements:

FCC 15.203

An intentional radiator shall be designed to ensure that no antenna other than that furnished by the responsible party shall be used with the device.

Verdict:

The EUT has an internal antenna which is not user accessible. Hence it complies with the antenna requirements.

5.1.3 Restricted Bands of Operation

RESULT:

PASS

Requirements:

FCC 15.205 and RSS-Gen 8.10

Only spurious emissions are permitted in any of the restricted frequency bands, unless otherwise specified.

Verdict:

The EUT operation frequency range is 2412-2462MHz. Therefore, only spurious emissions may be found in the restricted bands of operation and the EUT complies with the restricted frequency band requirement.

5.2 Conducted Measurements at Antenna Port

5.2.1 Conducted Output Power

RESULT:

PASS

Date of testing: 2016-01-14

Ambient temperature: 23°C

Relative humidity: 24%

Atmospheric pressure: 1006hPa

Requirements:

FCC 15.247(b)(1) and RSS-247 §5.4(2)

For systems using digital modulation in the 2400-2483.5MHz band, the maximum peak output power is 1W (30dBm).

If transmitting antennas of directional gain greater than 6dBi are used, the conducted output power from the intentional radiator shall be reduced by the amount in dB that the directional gain of the antenna exceeds 6dBi.

Test procedure:

ANSI C63.10-2013, RSS-Gen 6.12 and KDB Publication No. 558074 D01.

The maximum peak output power was measured at the antenna port with a power sensor.

The readings of the measurements take into account the loss generated by all the involved cables.

The measurement was performed at all the available modulations (data rates) in order to identify the one producing the highest output power for each protocol.

The results given here below indicate the worst case data rate for each protocol. All other measurements described in this test report for the evaluation of the radio properties of the EUT have been performed using these data rates.

Table 4: Conducted Output Power, IEEE 802.11b

Frequency [MHz]	Data Rate [Mbps]	Output Power [dBm]	Limit [dBm]	Margin [dB]
2412	1	15.94	30.00	14.06
2412	2	16.03	30.00	13.97
2412	5.5	16.12	30.00	13.88
2412	11	16.16	30.00	13.84
2437	1	16.12	30.00	13.88
2437	2	16.15	30.00	13.85
2437	5.5	16.22	30.00	13.78
2437	11	16.27	30.00	13.73
2462	1	15.98	30.00	14.02
2462	2	16.00	30.00	14.00
2462	5.5	16.06	30.00	13.94
2462	11	16.11	30.00	13.89

Notes: Output power = Reading + Correction factor
 $mW = 10^{(dBm/10)}$
 $dBm = 10 \times \log(mW)$

Grey shading area shows the highest power in the corresponding modulation.

Table 5: Conducted Output Power, IEEE 802.11g

Frequency [MHz]	Data Rate [Mbps]	Output Power [dBm]	Limit [dBm]	Margin [dB]
2412	6	19.13	30.00	10.87
2412	9	19.17	30.00	10.83
2412	12	19.18	30.00	10.82
2412	18	19.25	30.00	10.75
2412	24	19.27	30.00	10.73
2412	36	19.18	30.00	10.82
2412	48	19.17	30.00	10.83
2412	54	19.19	30.00	10.81
2437	6	19.06	30.00	10.94
2437	9	19.12	30.00	10.88
2437	12	19.14	30.00	10.86
2437	18	19.18	30.00	10.82
2437	24	19.18	30.00	10.82
2437	36	19.08	30.00	10.92
2437	48	19.09	30.00	10.91
2437	54	19.09	30.00	10.91
2462	6	18.92	30.00	11.08
2462	9	18.92	30.00	11.08
2462	12	18.97	30.00	11.03
2462	18	19.00	30.00	11.00
2462	24	19.05	30.00	10.95
2462	36	18.93	30.00	11.07
2462	48	18.89	30.00	11.11
2462	54	18.90	30.00	11.10

Notes: Output power = Reading + Correction factor
 $mW = 10^{(dBm/10)}$
 $dBm = 10 \times \log(mW)$

Grey shading area shows the highest power in the corresponding modulation.

Table 6: Conducted Output Power, IEEE 802.11n (20HT)

Frequency [MHz]	MCS Number	Output Power [dBm]	Limit [dBm]	Margin [dB]
2412	MCS0	19.16	30.00	10.84
2412	MCS1	19.17	30.00	10.83
2412	MCS2	19.21	30.00	10.79
2412	MCS3	19.23	30.00	10.77
2412	MCS4	19.16	30.00	10.84
2412	MCS5	19.20	30.00	10.80
2412	MCS6	19.13	30.00	10.87
2412	MCS7	19.04	30.00	10.96
2437	MCS0	19.10	30.00	10.90
2437	MCS1	19.09	30.00	10.91
2437	MCS2	19.13	30.00	10.87
2437	MCS3	19.17	30.00	10.83
2437	MCS4	19.07	30.00	10.93
2437	MCS5	19.09	30.00	10.91
2437	MCS6	19.09	30.00	10.91
2437	MCS7	18.96	30.00	11.04
2462	MCS0	18.93	30.00	11.07
2462	MCS1	18.94	30.00	11.06
2462	MCS2	18.99	30.00	11.01
2462	MCS3	18.99	30.00	11.01
2462	MCS4	18.92	30.00	11.08
2462	MCS5	18.91	30.00	11.09
2462	MCS6	18.93	30.00	11.07
2462	MCS7	18.93	30.00	11.07

Notes: Output power = Reading + Correction factor
 $mW = 10^{(dBm/10)}$
 $dBm = 10 \times \log(mW)$

Grey shading area shows the highest power in the corresponding modulation.

Table 7: Conducted Output Power, IEEE 802.11n (40HT)

Frequency [MHz]	MCS Number	Output Power [dBm]	Limit [dBm]	Margin [dB]
2422	MCS0	19.14	30.00	10.86
2422	MCS1	19.13	30.00	10.87
2422	MCS2	19.11	30.00	10.89
2422	MCS3	19.04	30.00	10.96
2422	MCS4	19.13	30.00	10.87
2422	MCS5	19.08	30.00	10.92
2422	MCS6	18.94	30.00	11.06
2422	MCS7	18.90	30.00	11.10
2437	MCS0	19.06	30.00	10.94
2437	MCS1	18.99	30.00	11.01
2437	MCS2	19.03	30.00	10.97
2437	MCS3	19.06	30.00	10.94
2437	MCS4	19.02	30.00	10.98
2437	MCS5	19.00	30.00	11.00
2437	MCS6	18.79	30.00	11.21
2437	MCS7	18.81	30.00	11.19
2452	MCS0	18.96	30.00	11.04
2452	MCS1	18.88	30.00	11.12
2452	MCS2	18.91	30.00	11.09
2452	MCS3	18.89	30.00	11.11
2452	MCS4	18.91	30.00	11.09
2452	MCS5	18.89	30.00	11.11
2452	MCS6	18.71	30.00	11.29
2452	MCS7	18.71	30.00	11.29

Notes: Output power = Reading + Correction factor
 $mW = 10^{(dBm/10)}$
 $dBm = 10 \times \log(mW)$

Grey shading area shows the highest power in the corresponding modulation.

5.2.2 6dB Bandwidth

RESULT:

PASS

Date of testing: 2016-01-14, 2016-01-15, 2016-01-16

Ambient temperature: 23, 24, 23°C

Relative humidity: 24, 24, 25%

Atmospheric pressure: 1006, 1012, 1010hPa

Requirements:

FCC 15.247(a)(2) and RSS-247 §5.2(1)

For systems using digital modulation in the 2400-2483.5MHz band, the 6dB bandwidth shall be at least 500kHz.

Test procedure:

ANSI C63.10-2013, RSS-Gen 6.6 and KDB Publication No. 558074 D01.

The 6dB bandwidth was measured at the antenna port with a spectrum analyzer using a peak detector. The resolution bandwidth was set to 100kHz and the video bandwidth to 300kHz. Markers placed at the lowest and highest intersections of the trace with a 6dBc line were used to calculate the emission bandwidth.

Table 8: 6dB Bandwidth, IEEE 802.11b

Operating Frequency [MHz]	6dB Bandwidth [MHz]	Limit [MHz]
2412	10.256	>0.5
2437	9.535	>0.5
2462	10.096	>0.5

Figure 2: 6dB Bandwidth, Mode A (2412MHz), IEEE 802.11b

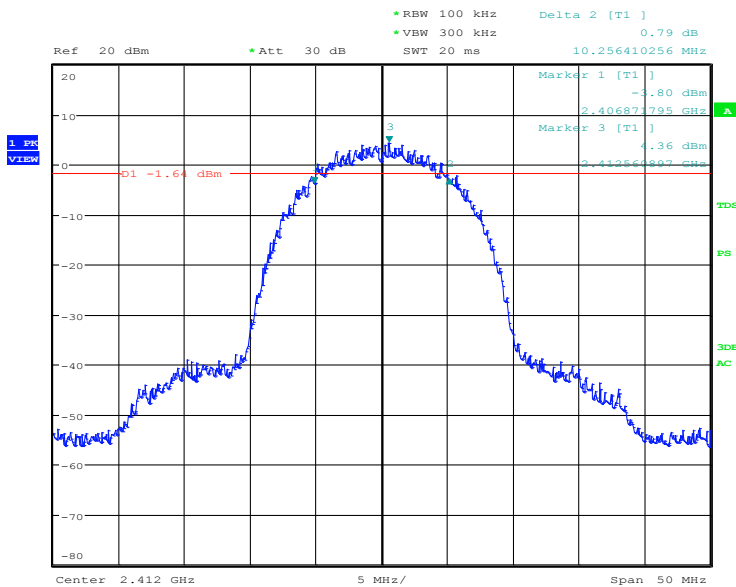

6dB bandwidth, mode 11b, A1
 Date: 14.JAN.2016 14:40:02

Figure 3: 6dB Bandwidth, Mode B (2437MHz), IEEE 802.11b

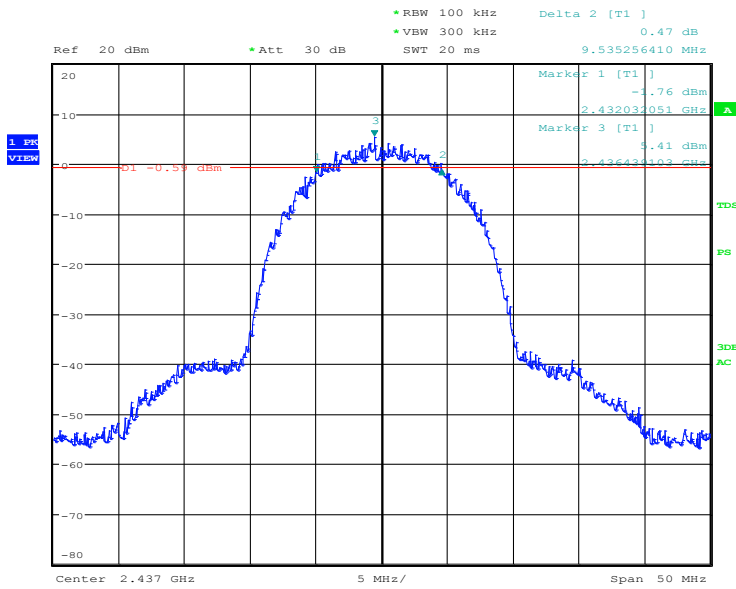

6dB bandwidth, mode 11b, B1
Date: 14.JAN.2016 14:51:00

Figure 4: 6dB Bandwidth, Mode C (2462MHz), IEEE 802.11b

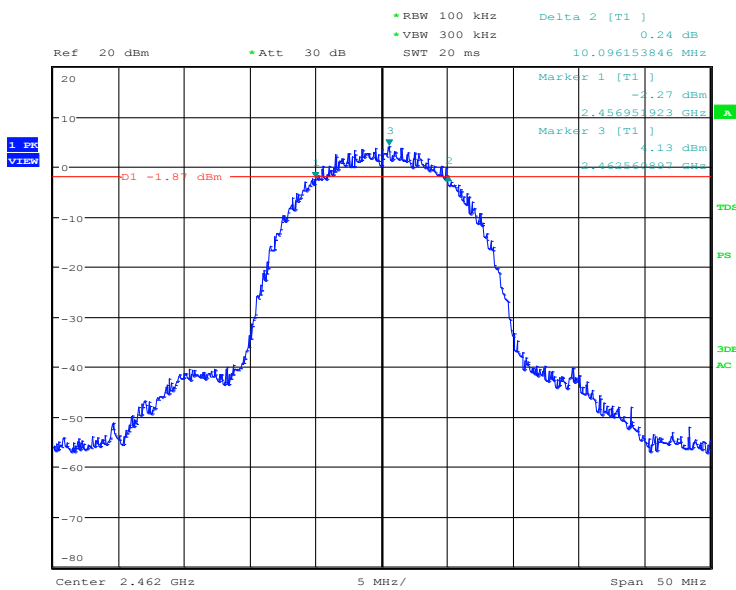

6dB bandwidth, mode 11b, C1
Date: 14.JAN.2016 15:09:00

Table 9: 6dB Bandwidth, IEEE 802.11g

Operating Frequency [MHz]	6dB Bandwidth [MHz]	Limit [MHz]
2412	15.304	>0.5
2437	15.304	>0.5
2462	15.224	>0.5

Figure 5: 6dB Bandwidth, Mode A (2412MHz), IEEE 802.11g

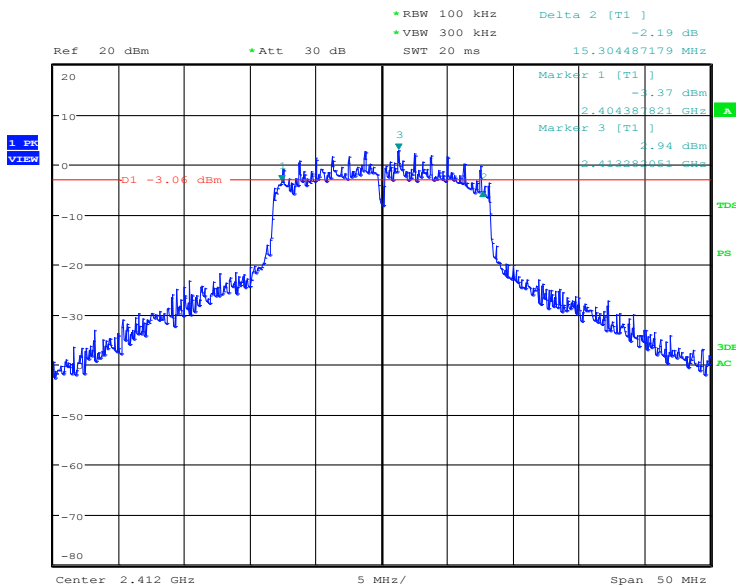

6dB bandwidth, mode 11g, A1
 Date: 14.JAN.2016 15:19:24

Figure 6: 6dB Bandwidth, Mode B (2437MHz), IEEE 802.11g

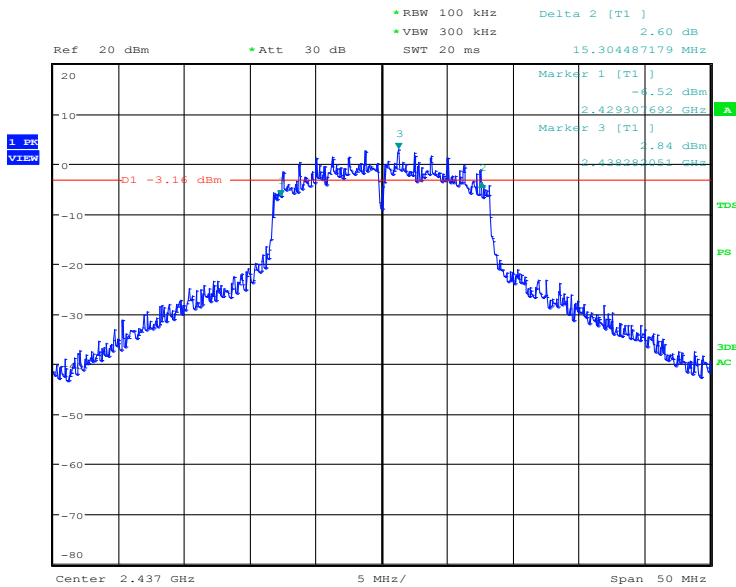

6dB bandwidth, mode 11g, B1
Date: 14.JAN.2016 15:54:12

Figure 7: 6dB Bandwidth, Mode C (2462MHz), IEEE 802.11g

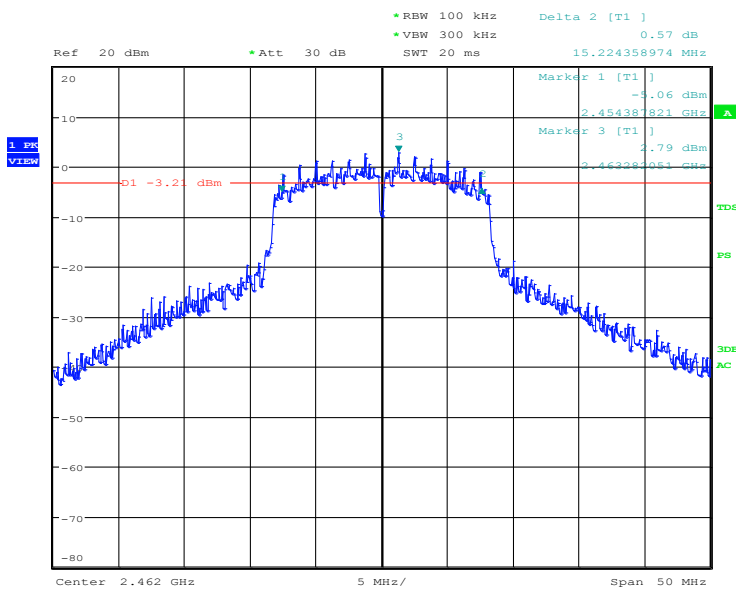

6dB bandwidth, mode 11g, C1
Date: 14.JAN.2016 16:03:23

Produkte
 Products

Prüfbericht - Nr.: 50036571 001
 Test Report No.:

Seite 27 von 114
 Page 27 of 114

Table 10: 6dB Bandwidth, IEEE 802.11n (20HT)

Operating Frequency [MHz]	6dB Bandwidth [MHz]	Limit [MHz]
2412	16.186	>0.5
2437	15.224	>0.5
2462	15.224	>0.5

Figure 8: 6dB Bandwidth, Mode A (2412MHz), IEEE 802.11n (20HT)

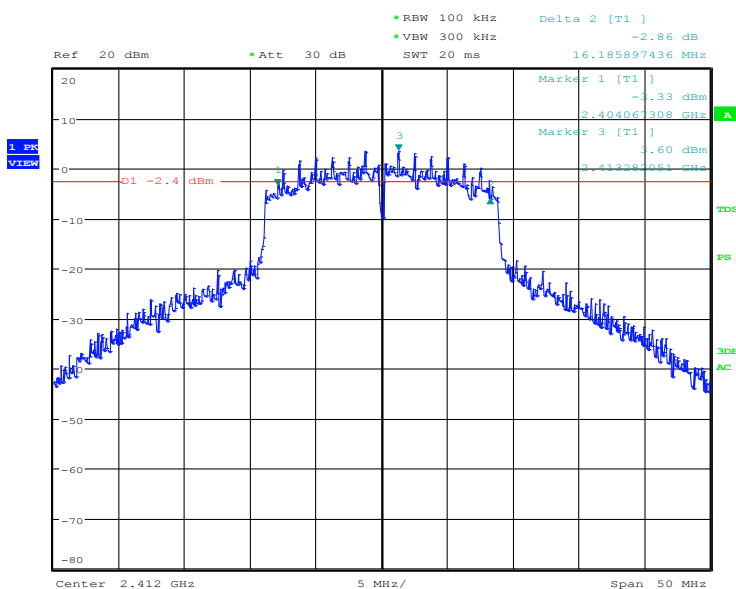

6dB bandwidth, mode 11n (20M), A1
 Date: 14.JAN.2016 16:14:29

Figure 9: 6dB Bandwidth, Mode B (2437MHz), IEEE 802.11n (20HT)

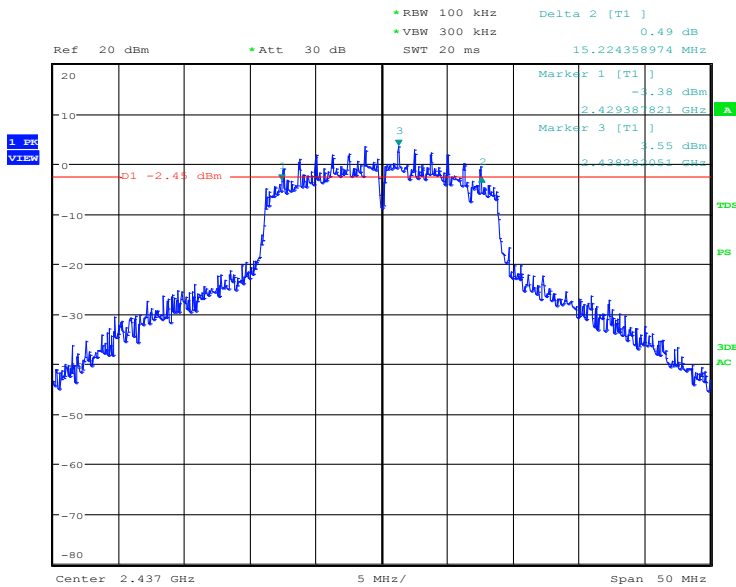

6dB bandwidth, mode 11n (20M), B1
Date: 14.JAN.2016 16:25:38

Figure 10: 6dB Bandwidth, Mode C (2462MHz), IEEE 802.11n (20HT)

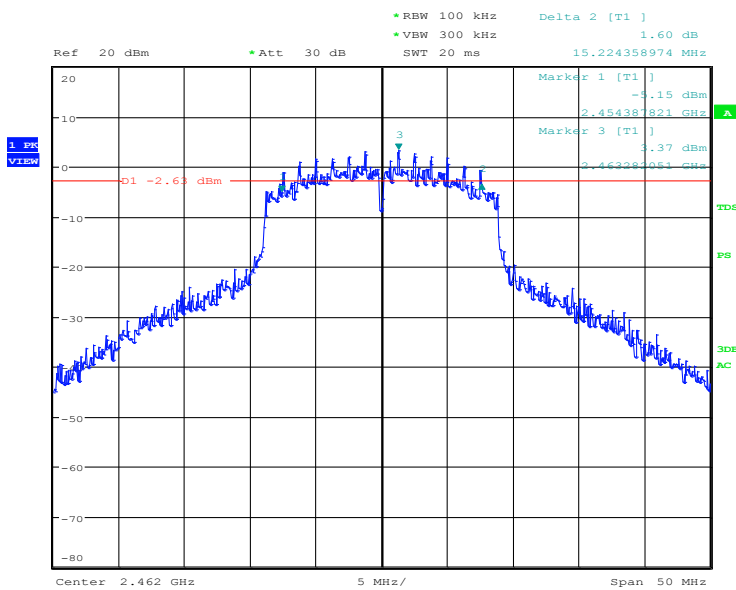

6dB bandwidth, mode 11n (20M), C1
Date: 14.JAN.2016 16:37:51

Table 11: 6dB Bandwidth, IEEE 802.11n (40HT)

Operating Frequency [MHz]	6dB Bandwidth [MHz]	Limit [MHz]
2422	34.054	>0.5
2437	34.054	>0.5
2452	34.054	>0.5

Figure 11: 6dB Bandwidth, Mode A (2422MHz), IEEE 802.11n (40HT)

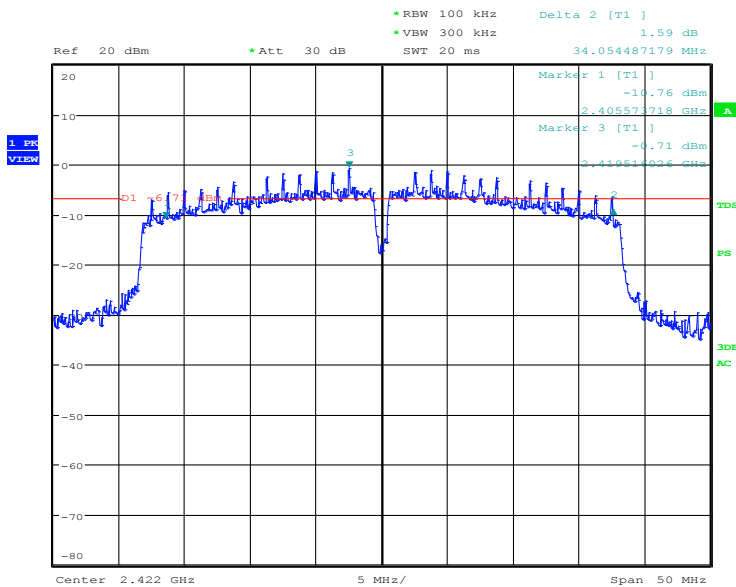

6dB bandwidth, mode 11n (40M), A1
 Date: 16.JAN.2016 14:02:34

Figure 12: 6dB Bandwidth, Mode B (2437MHz), IEEE 802.11n (40HT)

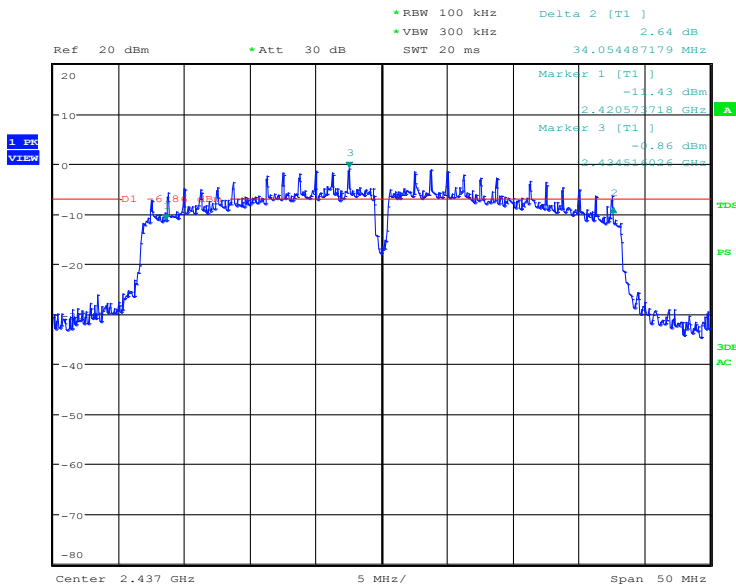

6dB bandwidth, mode 11n (40M), B1
Date: 16.JAN.2016 14:10:55

Figure 13: 6dB Bandwidth, Mode C (2452MHz), IEEE 802.11n (40HT)

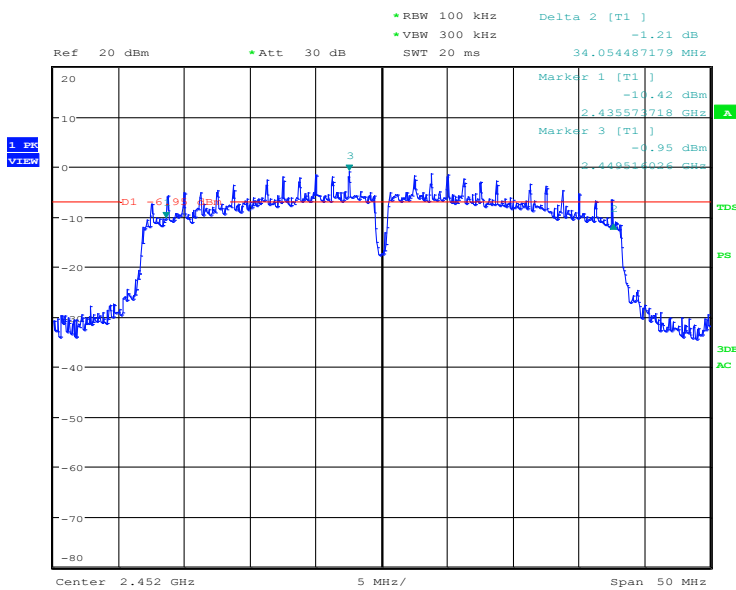

6dB bandwidth, mode 11n (40M), C1
Date: 16.JAN.2016 14:16:50

5.2.3 99% Bandwidth

Date of testing: 2016-01-14, 2016-01-15, 2016-01-16

Ambient temperature: 23, 24, 23°C

Relative humidity: 24, 24, 25%

Atmospheric pressure: 1006, 1012, 1010hPa

Requirements:

RSS-Gen 6.6

The 99% bandwidth shall be reported according to RSS-Gen 6.6.

Test procedure:

RSS-Gen 6.6 and ANSI C63.10-2013

The 99% bandwidth was measured at the antenna port with a spectrum analyzer using a sample detector. The resolution bandwidth was set in the range of 1% to 5% of the occupied bandwidth and video bandwidth was set to 3x RBW.

The 99% bandwidth was measured by using the OBW function of the analyzer with a 99% coverage setting.

Table 12: 99% Bandwidth, IEEE 802.11b

Operating Frequency [MHz]	99% Bandwidth [MHz]
2412	14.663
2437	14.663
2462	14.663

Note: This RBW was set to 2.04% of the OBW. $(0.3 \text{ MHz} / 14.663 \text{ MHz}) \times 100 = 2.04\%$

Figure 14: 99% Bandwidth, Mode A (2412MHz), IEEE 802.11b

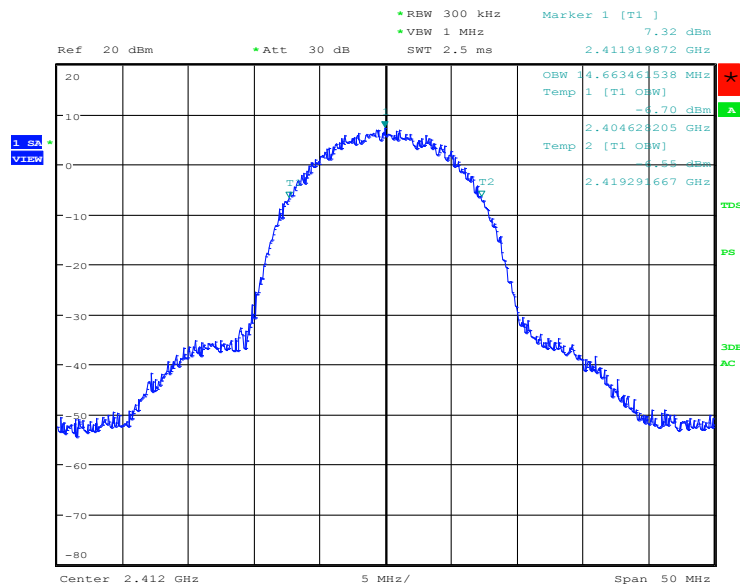

99% bandwidth, mode 11b, A1
 Date: 14.JAN.2016 15:06:09

Figure 15: 99% Bandwidth, Mode B (2437MHz), IEEE 802.11b

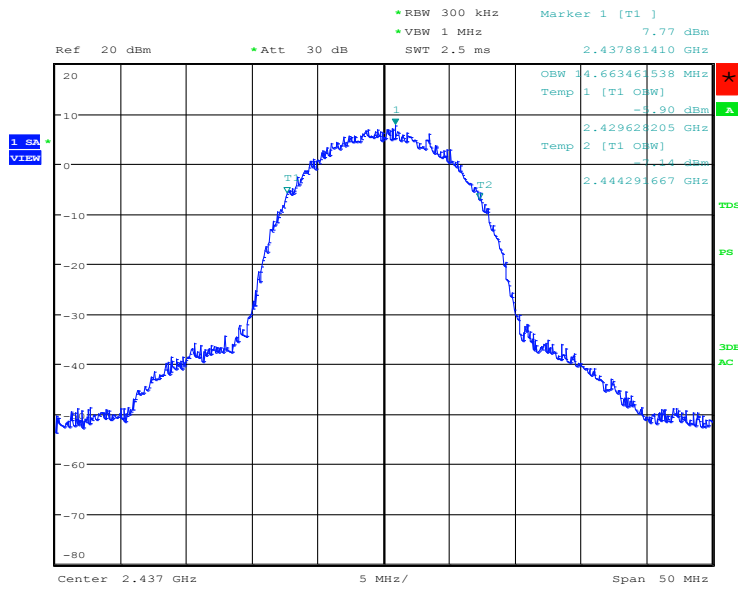

99% bandwidth, mode 11b, B1
Date: 14.JAN.2016 15:07:41

Figure 16: 99% Bandwidth, Mode C (2462MHz), IEEE 802.11b

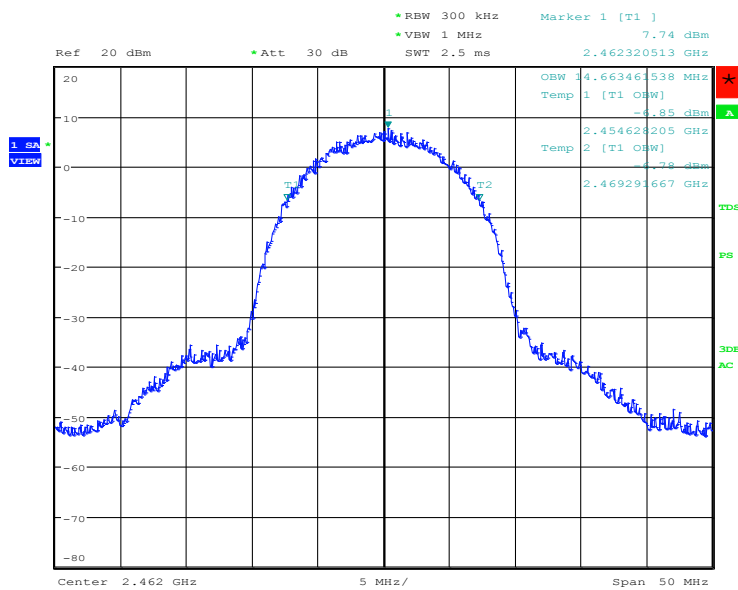

99% bandwidth, mode 11b, C1
Date: 14.JAN.2016 15:09:19

Table 13: 99% Bandwidth, IEEE 802.11g

Operating Frequency [MHz]	99% Bandwidth [MHz]
2412	17.147
2437	16.987
2462	16.987

Note: This RBW was set to 1.76% of the OBW. $(0.3 \text{ MHz} / 16.987 \text{ MHz}) \times 100 = 1.76\%$

Figure 17: 99% Bandwidth, Mode A (2412MHz), IEEE 802.11g

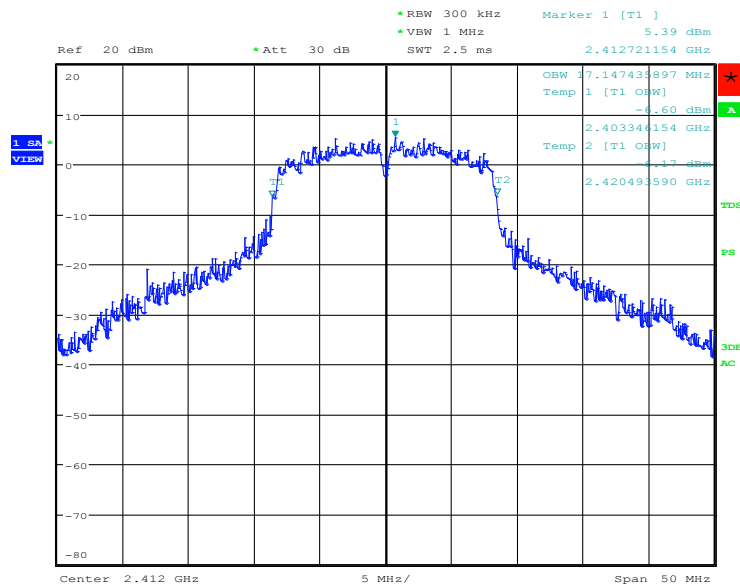

99% bandwidth, mode 11g, A1
 Date: 14.JAN.2016 15:20:09

Figure 18: 99% Bandwidth, Mode B (2437MHz), IEEE 802.11g

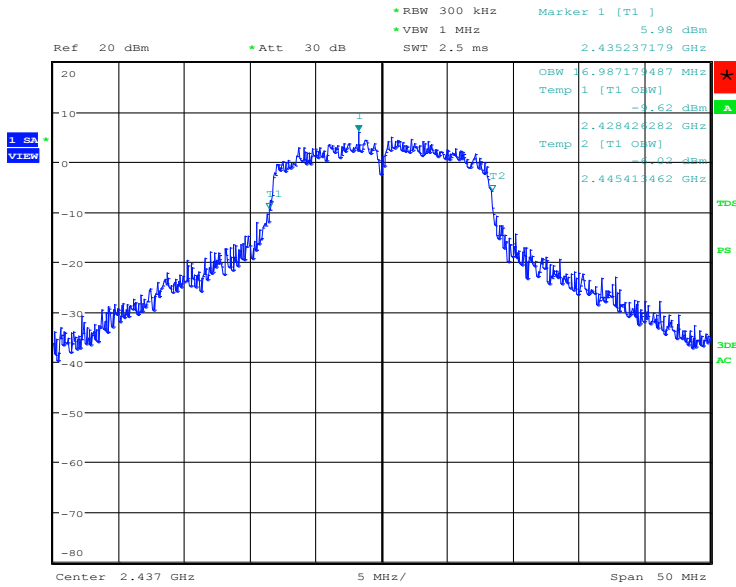

99% bandwidth, mode 11g, B1
Date: 14.JAN.2016 15:54:30

Figure 19: 99% Bandwidth, Mode C (2462MHz), IEEE 802.11g

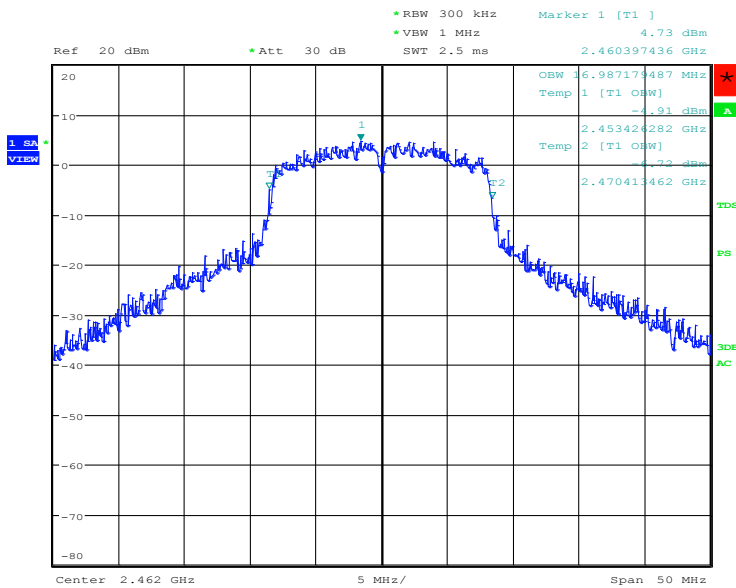

99% bandwidth, mode 11g, C1
Date: 14.JAN.2016 16:03:44

Table 14: 99% Bandwidth, IEEE 802.11n (20HT)

Operating Frequency [MHz]	99% Bandwidth [MHz]
2412	18.029
2437	17.949
2462	17.949

Note: This RBW was set to 1.67% of the OBW. $(0.3 \text{ MHz} / 17.949 \text{ MHz}) \times 100 = 1.67\%$

Figure 20: 99% Bandwidth, Mode A (2412MHz), IEEE 802.11n (20HT)

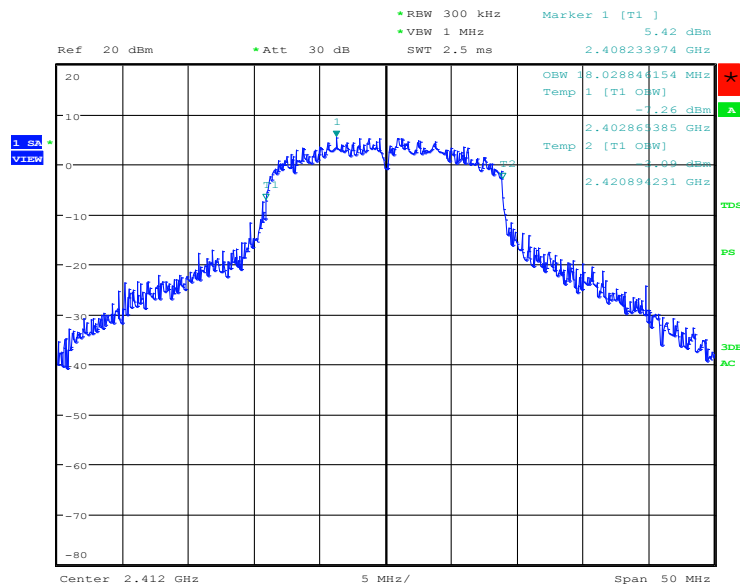

99% bandwidth, mode 11n (20M), A1
 Date: 14.JAN.2016 16:15:06

Figure 21: 99% Bandwidth, Mode B (2437MHz), IEEE 802.11n (20HT)

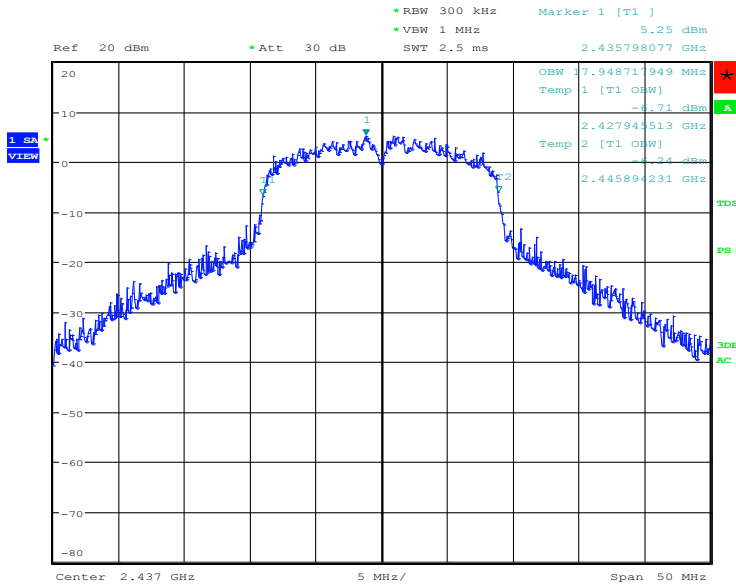

99% bandwidth, mode 11n (20M), B1
 Date: 14.JAN.2016 16:26:00

Figure 22: 99% Bandwidth, Mode C (2462MHz), IEEE 802.11n (20HT)

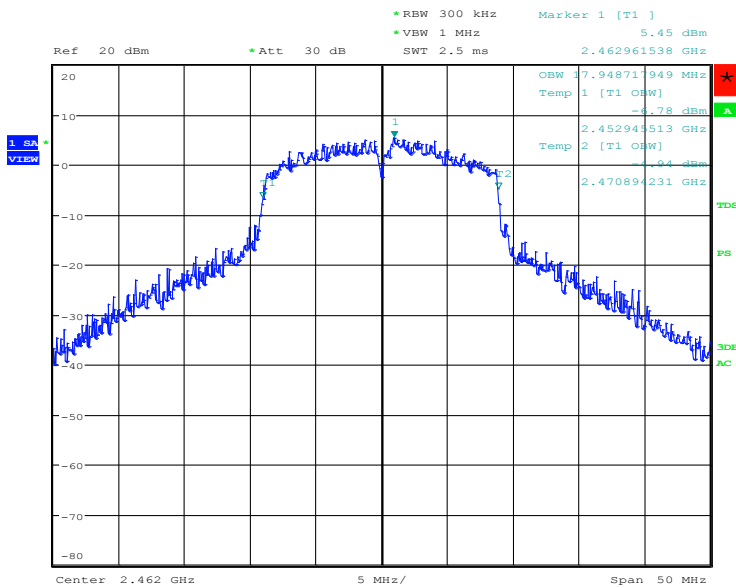

99% bandwidth, mode 11n (20M), C1
 Date: 14.JAN.2016 16:38:11

Table 15: 99% Bandwidth, IEEE 802.11n (40HT)

Operating Frequency [MHz]	99% Bandwidth [MHz]
2422	36.538
2437	36.538
2452	36.859

Note: This RBW was set to 2.74% of the OBW. $(1 \text{ MHz} / 36.538 \text{ MHz}) \times 100 = 2.74\%$

Figure 23: 99% Bandwidth, Mode A (2422MHz), IEEE 802.11n (40HT)

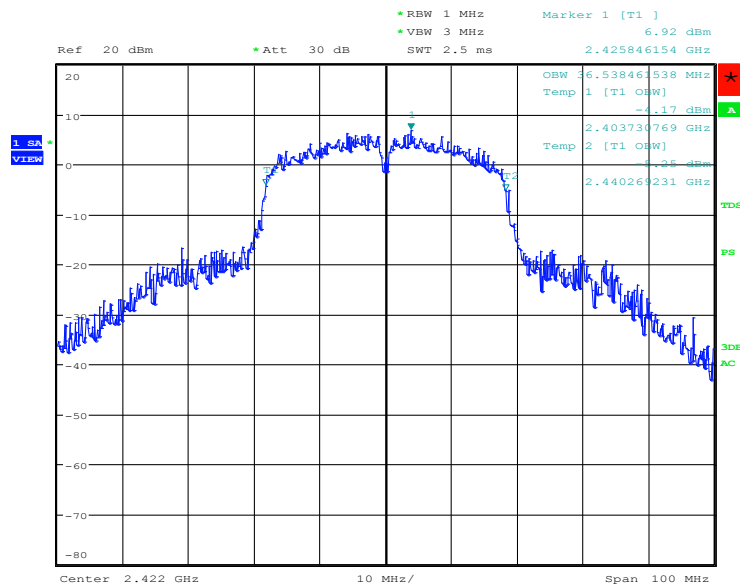

99% bandwidth, mode 11n (40M), A1
 Date: 16.JAN.2016 14:03:19

Figure 24: 99% Bandwidth, Mode B (2437MHz), IEEE 802.11n (40HT)

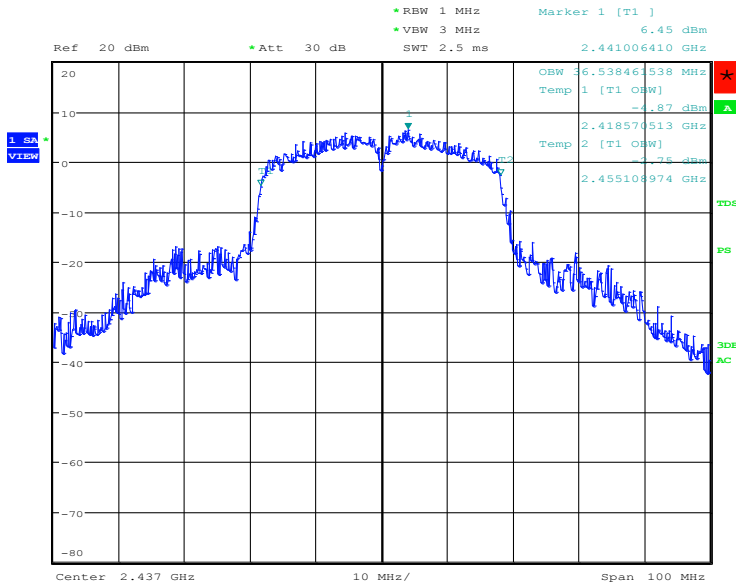

99% bandwidth, mode 11n (40M), B1
Date: 16.JAN.2016 14:11:38

Figure 25: 99% Bandwidth, Mode C (2452MHz), IEEE 802.11n (40HT)

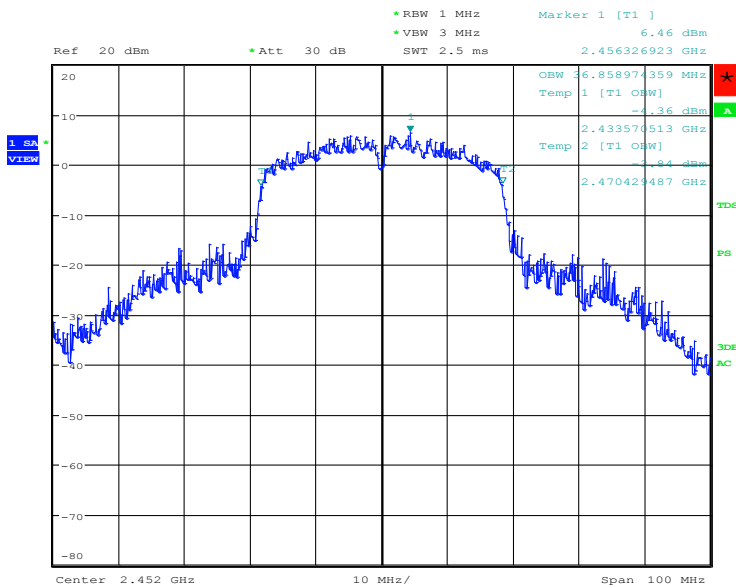

99% bandwidth, mode 11n (40M), C1
Date: 16.JAN.2016 14:17:45

5.2.4 Conducted Spurious Emissions

RESULT:

PASS

Date of testing: 2016-01-14, 2016-01-15

Ambient temperature: 23, 24°C

Relative humidity: 24, 24%

Atmospheric pressure: 1006, 1012hPa

Requirements:

FCC 15.247(d) and RSS-247 §5.5

In any 100kHz bandwidth outside the frequency band in which the intentional radiator is operating, the RF power shall be at least 20dB below that of the maximum in-band 100kHz emission.

Test procedure:

ANSI C63.10-2013, RSS-Gen 6.13 and KDB Publication No. 558074 D01.

The conducted spurious emissions were measured at the antenna port with a spectrum analyzer using a peak detector. The resolution bandwidth was set to 100kHz and the video bandwidth to 300kHz. Measurements were performed from 30MHz to 25GHz (10th harmonics).

The readings of the measurements take into account the loss generated by all the involved cables.

Figure 26: Conducted Spurious Emissions, 30MHz - 12GHz, Mode A (2412MHz), IEEE 802.11b

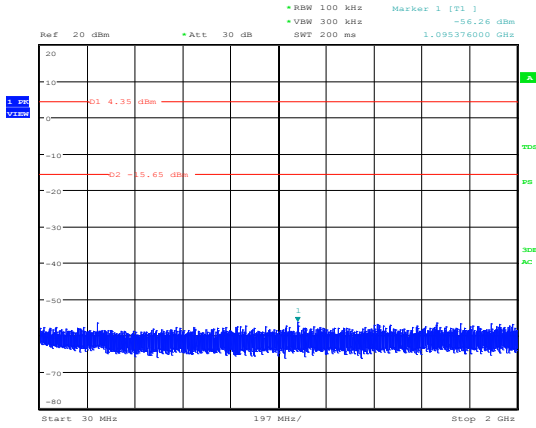

Conducted spurious emissions, mode 11b, A1
 Date: 14.JAN.2016 14:44:27

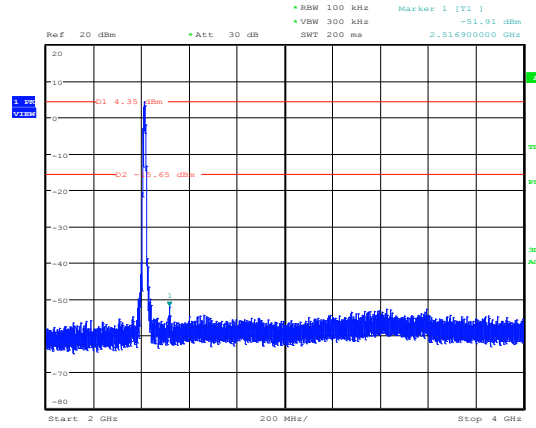

Conducted spurious emissions, mode 11b, A1
 Date: 14.JAN.2016 15:46:13

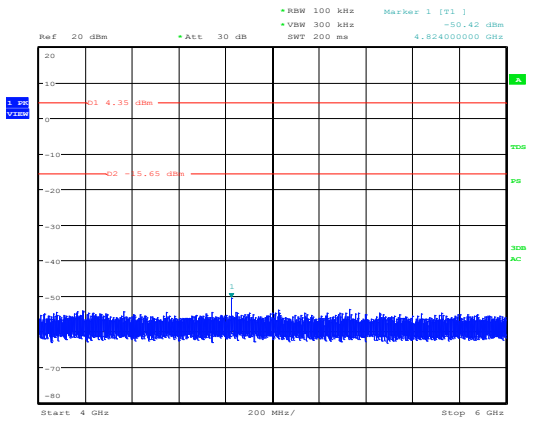

Conducted spurious emissions, mode 11b, A1
 Date: 14.JAN.2016 14:45:05

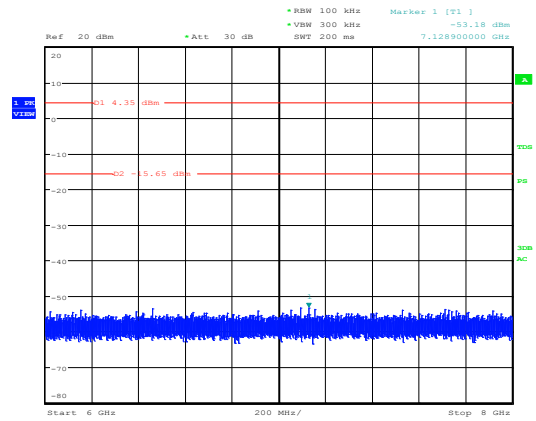

Conducted spurious emissions, mode 11b, A1
 Date: 14.JAN.2016 14:45:24

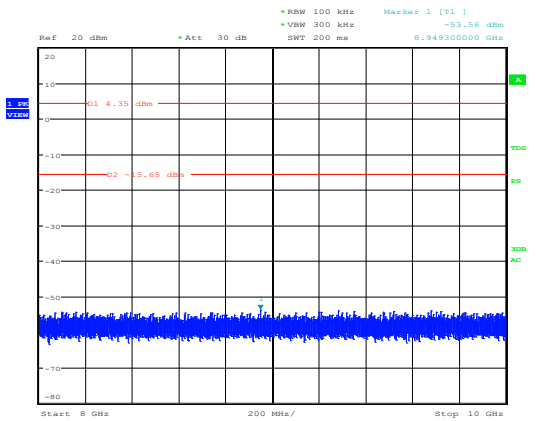

Conducted spurious emissions, mode 11b, A1
 Date: 14.JAN.2016 14:45:44

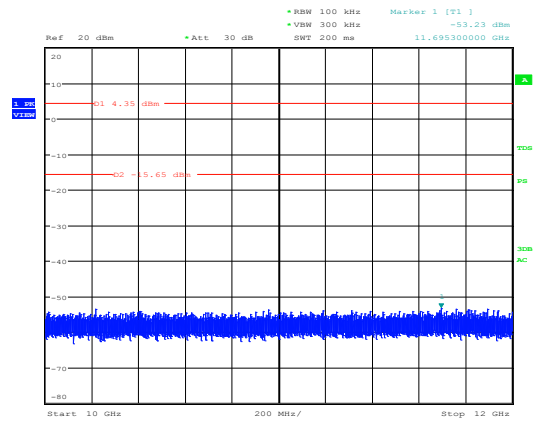

Conducted spurious emissions, mode 11b, A1
 Date: 14.JAN.2016 14:46:03

Figure 27: Conducted Spurious Emissions, 12 - 24GHz, Mode A (2412MHz), IEEE 802.11b

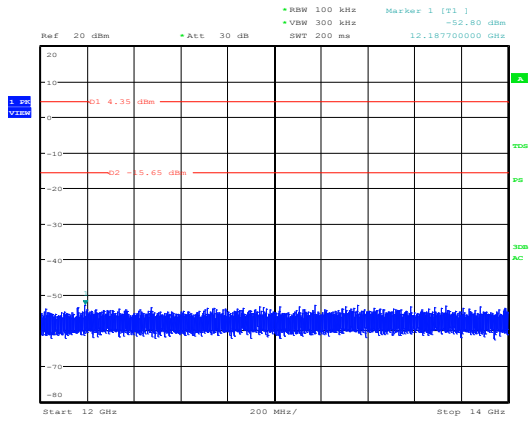

Conducted spurious emissions, mode 11b, A1
 Date: 14.JAN.2016 14:46:21

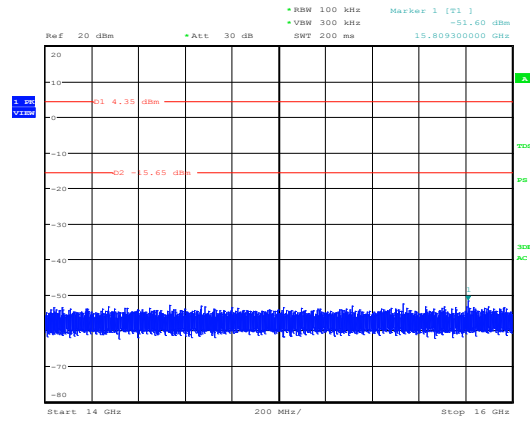

Conducted spurious emissions, mode 11b, A1
 Date: 14.JAN.2016 14:46:40

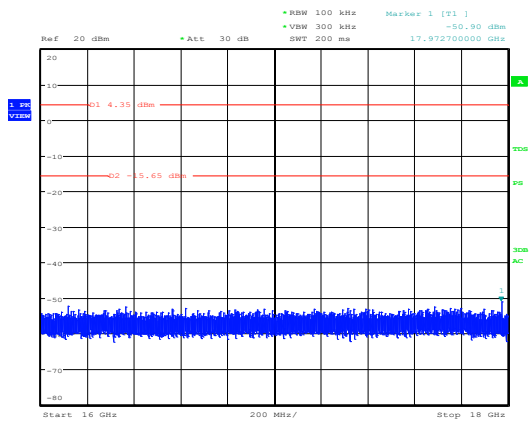

Conducted spurious emissions, mode 11b, A1
 Date: 14.JAN.2016 14:47:04

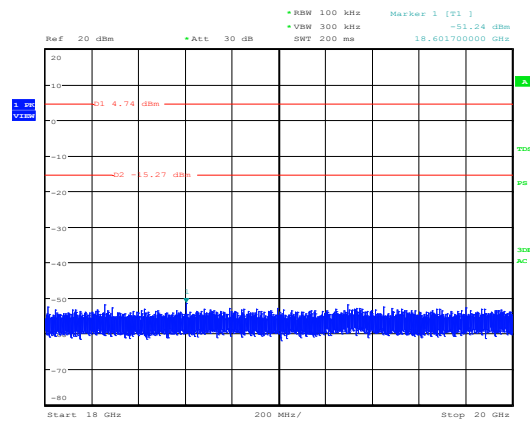

Conducted spurious emissions, mode 11b, B1
 Date: 14.JAN.2016 14:58:12

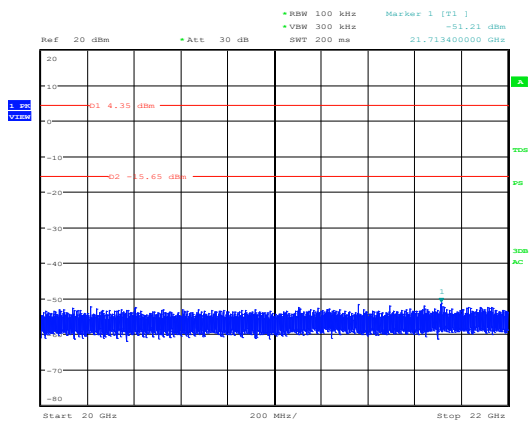

Conducted spurious emissions, mode 11b, A1
 Date: 14.JAN.2016 14:47:43

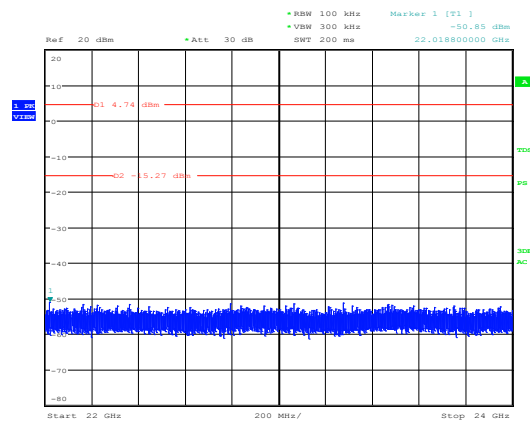

Conducted spurious emissions, mode 11b, B1
 Date: 14.JAN.2016 14:58:51

Produkte
Products

Prüfbericht - Nr.: 50036571 001
Test Report No.:

Seite 43 von 114
Page 43 of 114

Figure 28: Conducted Spurious Emissions, 24 - 25GHz, Mode A (2412MHz), IEEE 802.11b

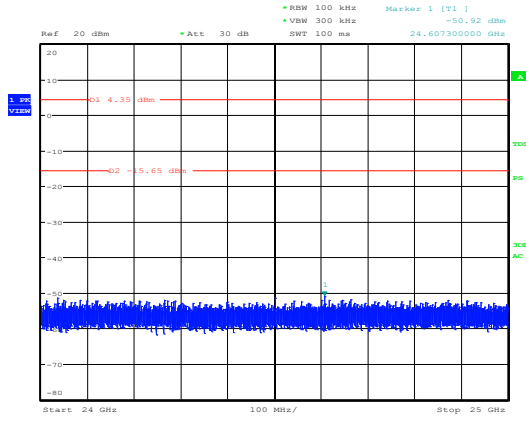

Conducted spurious emissions, mode 11b, A1
Date: 14.JAN.2016 14:48:21

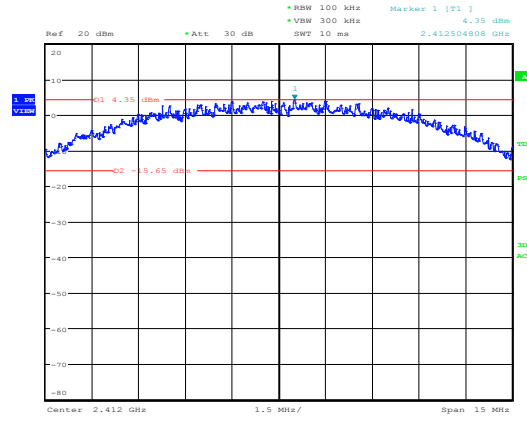

Conducted spurious emissions, mode 11b, A1
Date: 14.JAN.2016 14:44:01

Figure 29: Conducted Spurious Emissions, 30MHz - 12GHz, Mode B (2437MHz), IEEE 802.11b

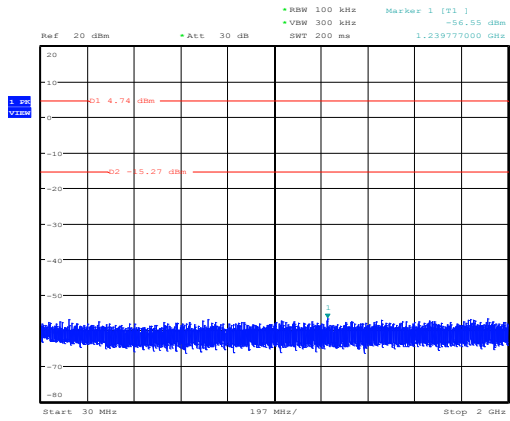

Conducted spurious emissions, mode 11b, B1
 Date: 14.JAN.2016 14:54:07

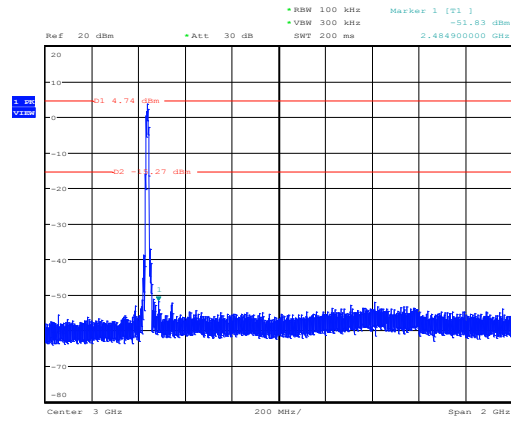

Conducted spurious emissions, mode 11b, B1
 Date: 14.JAN.2016 15:50:01

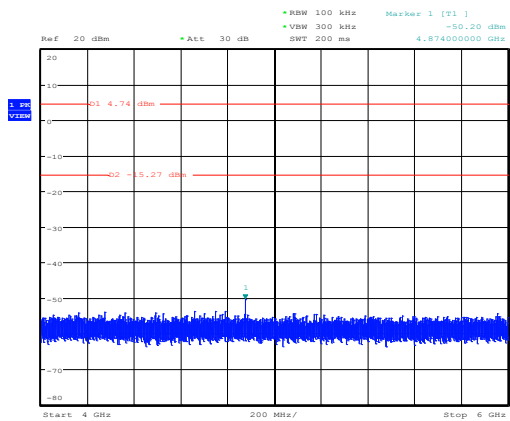

Conducted spurious emissions, mode 11b, B1
 Date: 14.JAN.2016 14:56:01

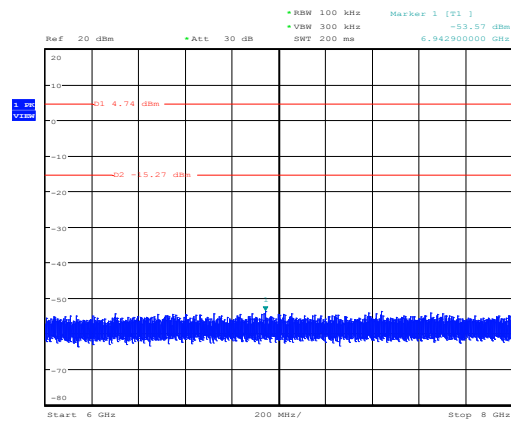

Conducted spurious emissions, mode 11b, B1
 Date: 14.JAN.2016 14:56:19

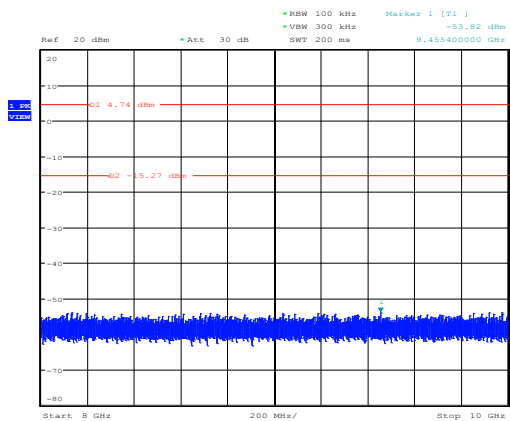

Conducted spurious emissions, mode 11b, B1
 Date: 14.JAN.2016 14:56:38

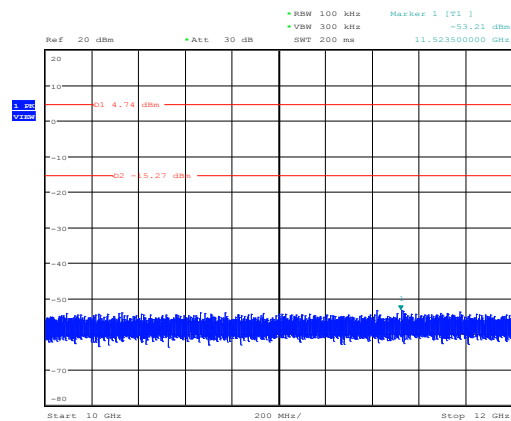

Conducted spurious emissions, mode 11b, B1
 Date: 14.JAN.2016 14:56:56

Figure 30: Conducted Spurious Emissions, 12 - 24GHz, Mode B (2437MHz), IEEE 802.11b

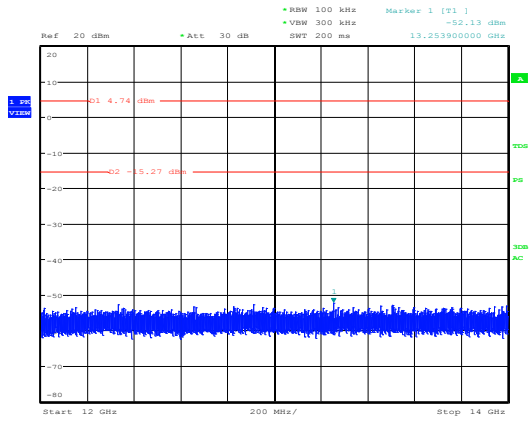

Conducted spurious emissions, mode 11b, B1
 Date: 14.JAN.2016 14:57:15

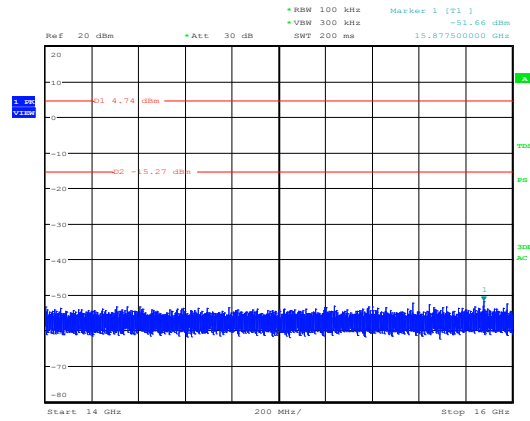

Conducted spurious emissions, mode 11b, B1
 Date: 14.JAN.2016 14:57:34

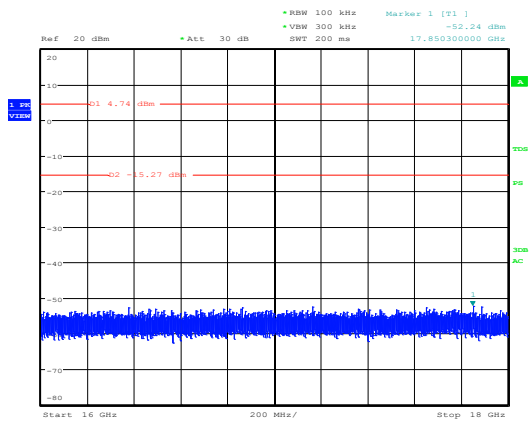

Conducted spurious emissions, mode 11b, B1
 Date: 14.JAN.2016 14:57:53

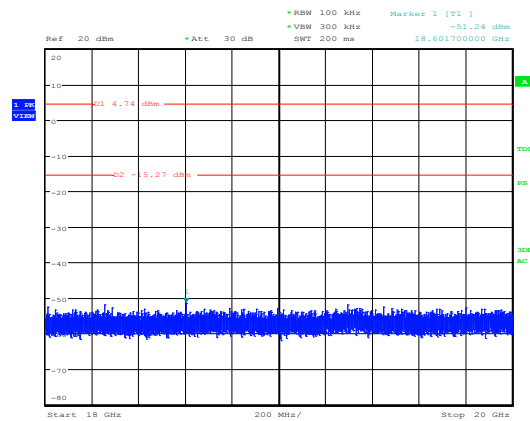

Conducted spurious emissions, mode 11b, B1
 Date: 14.JAN.2016 14:58:12

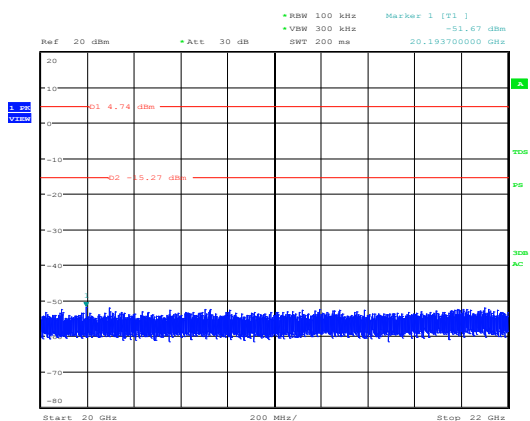

Conducted spurious emissions, mode 11b, B1
 Date: 14.JAN.2016 14:58:31

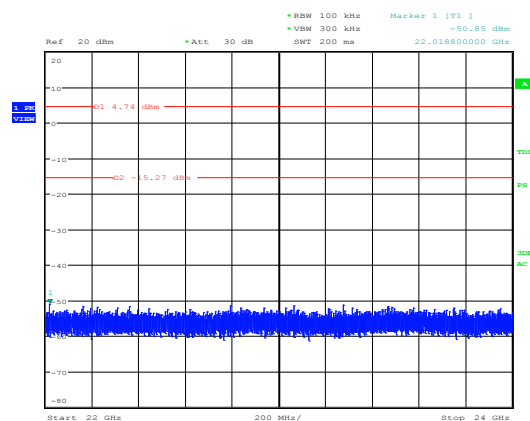

Conducted spurious emissions, mode 11b, B1
 Date: 14.JAN.2016 14:58:51

Produkte
Products

Prüfbericht - Nr.: 50036571 001
Test Report No.:

Seite 46 von 114
Page 46 of 114

Figure 31: Conducted Spurious Emissions, 24 - 25GHz, Mode B (2437MHz), IEEE 802.11b

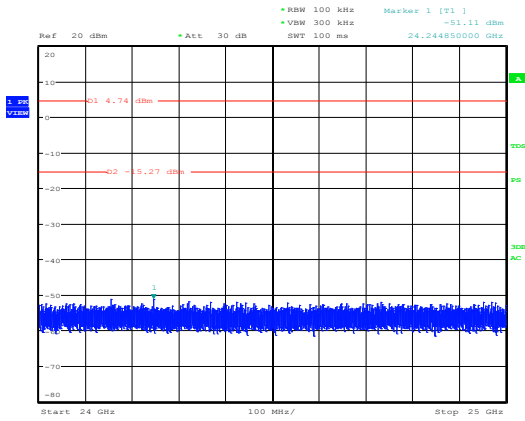

Conducted spurious emissions, mode 11b, B1
Date: 14.JAN.2016 14:59:10

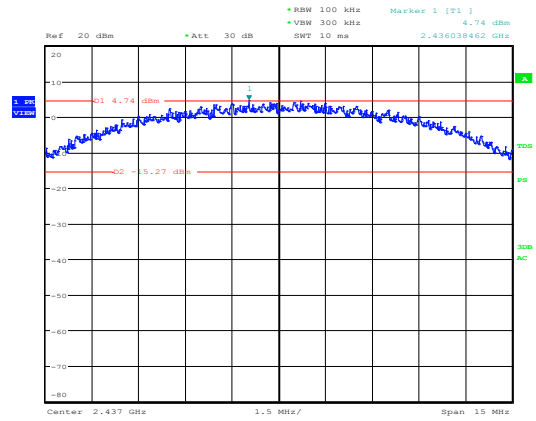

Conducted spurious emissions, mode 11b, B1
Date: 14.JAN.2016 14:52:49

Figure 32: Conducted Spurious Emissions, 30MHz - 12GHz, Mode C (2462MHz), IEEE 802.11b

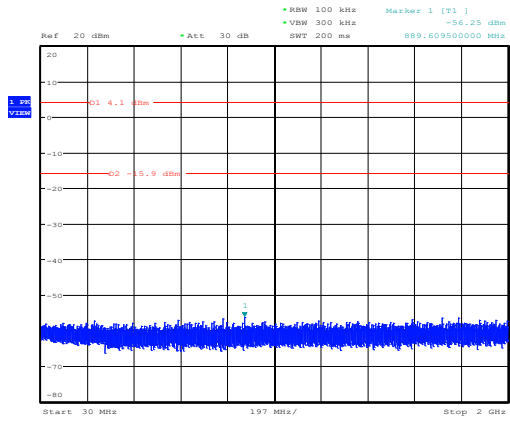

Conducted spurious emissions, mode 11b, C1
 Date: 14.JAN.2016 15:11:01

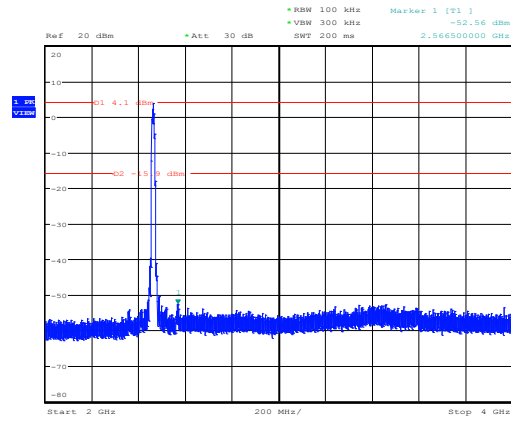

Conducted spurious emissions, mode 11b, C1
 Date: 14.JAN.2016 15:11:41

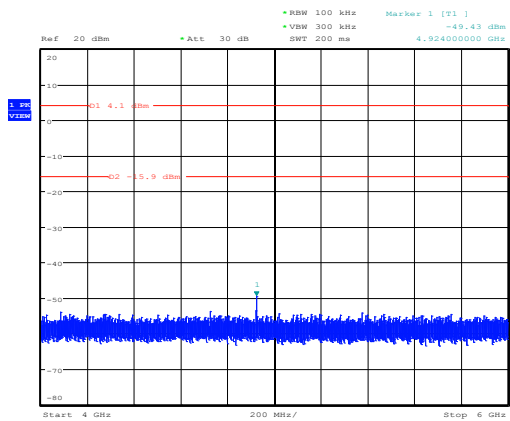

Conducted spurious emissions, mode 11b, C1
 Date: 14.JAN.2016 15:11:41

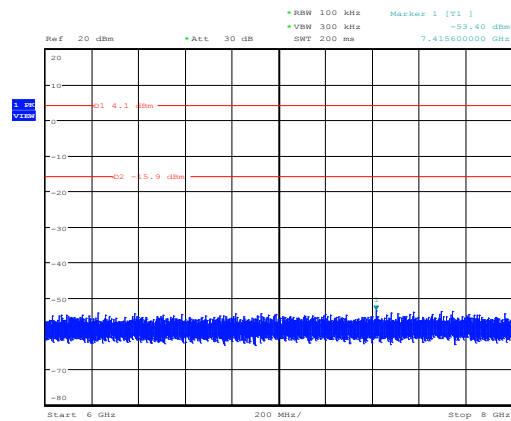

Conducted spurious emissions, mode 11b, C1
 Date: 14.JAN.2016 15:12:00

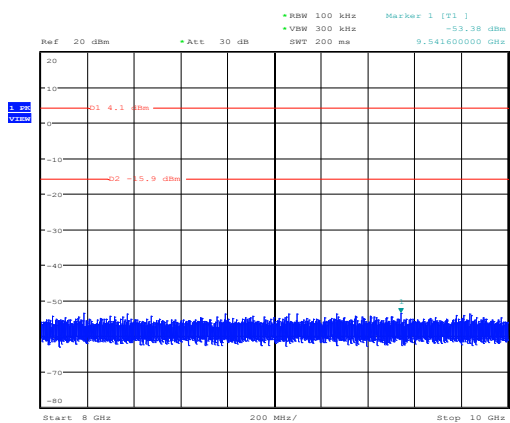

Conducted spurious emissions, mode 11b, C1
 Date: 14.JAN.2016 15:12:22

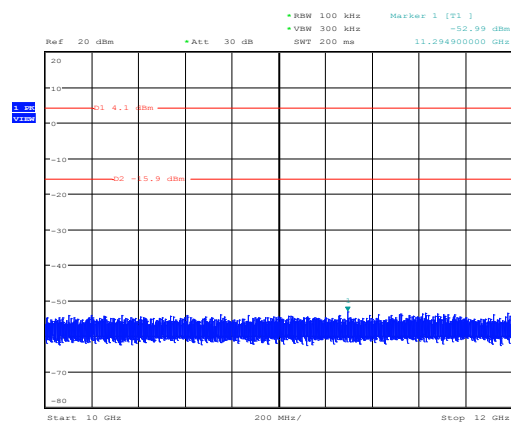

Conducted spurious emissions, mode 11b, C1
 Date: 14.JAN.2016 15:12:45

Figure 33: Conducted Spurious Emissions, 12 - 24GHz, Mode C (2462MHz), IEEE 802.11b

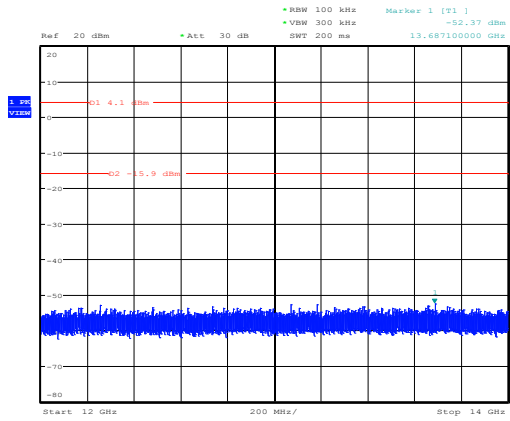

Conducted spurious emissions, mode 11b, C1
 Date: 14.JAN.2016 15:13:10

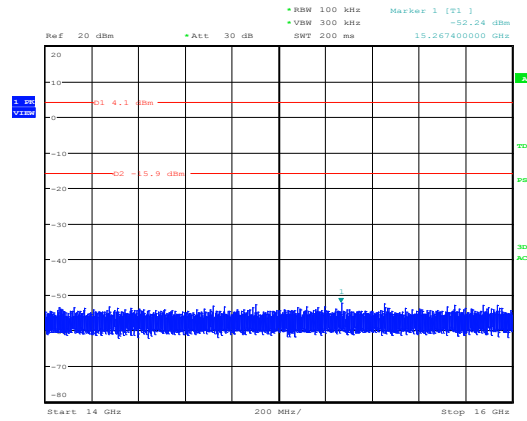

Conducted spurious emissions, mode 11b, C1
 Date: 14.JAN.2016 15:13:36

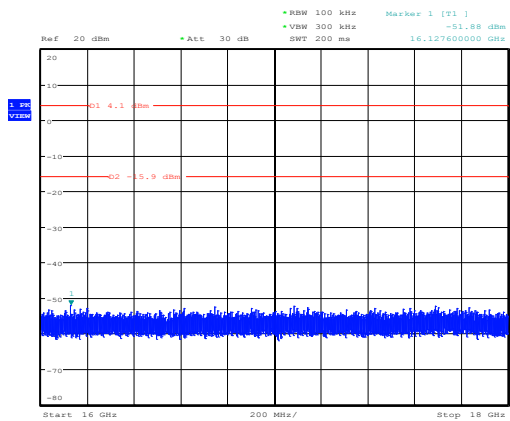

Conducted spurious emissions, mode 11b, C1
 Date: 14.JAN.2016 15:14:01

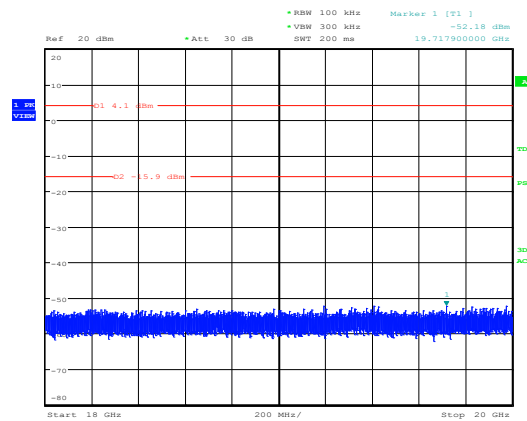

Conducted spurious emissions, mode 11b, C1
 Date: 14.JAN.2016 15:14:22

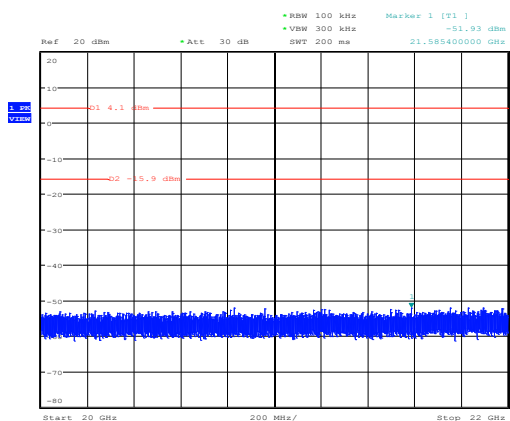

Conducted spurious emissions, mode 11b, C1
 Date: 14.JAN.2016 15:14:47

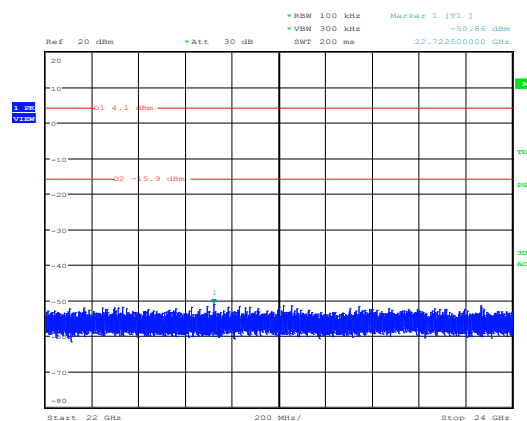

Conducted spurious emissions, mode 11b, C1
 Date: 14.JAN.2016 15:15:15

Produkte
Products

Prüfbericht - Nr.: **50036571 001**
Test Report No.:

Seite 49 von 114
Page 49 of 114

Figure 34: Conducted Spurious Emissions, 24 - 25GHz, Mode C (2462MHz) IEEE 802.11b

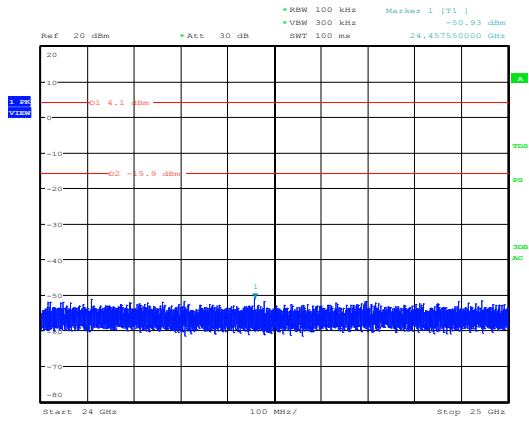

Conducted spurious emissions, mode 11b, C1
Date: 14.JAN.2016 15:15:37

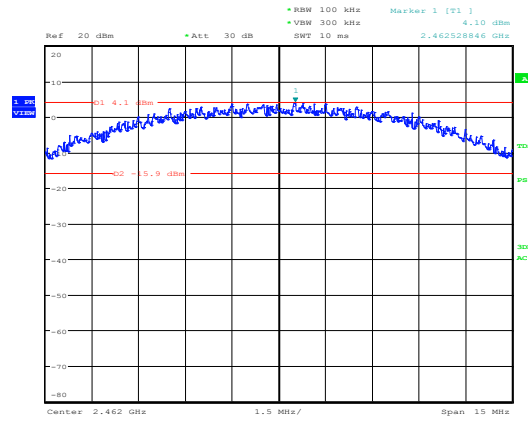

Conducted spurious emissions, mode 11b, C1
Date: 14.JAN.2016 15:10:42

Figure 35: Conducted Spurious Emissions, 30MHz - 12GHz, Mode A (2412MHz), IEEE 802.11g

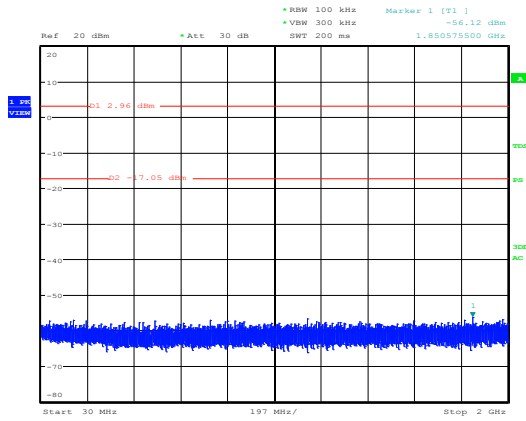

Conducted spurious emissions, mode 11g, A1
Date: 14.JAN.2016 15:22:32

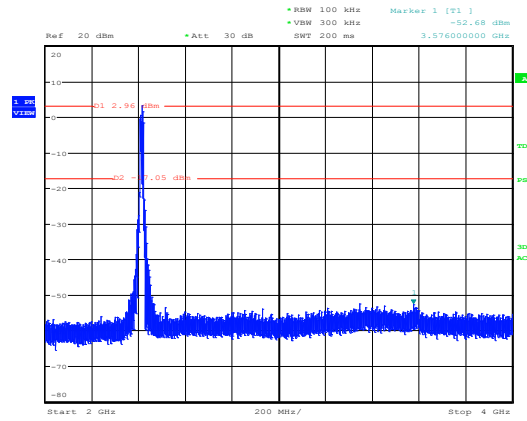

Conducted spurious emissions, mode 11g, A1
Date: 14.JAN.2016 15:40:13

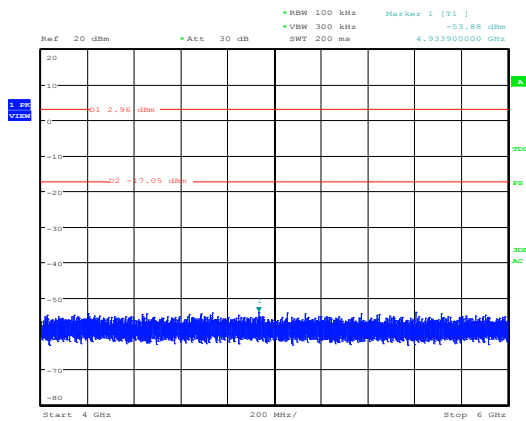

Conducted spurious emissions, mode 11g, A1
Date: 14.JAN.2016 15:23:16

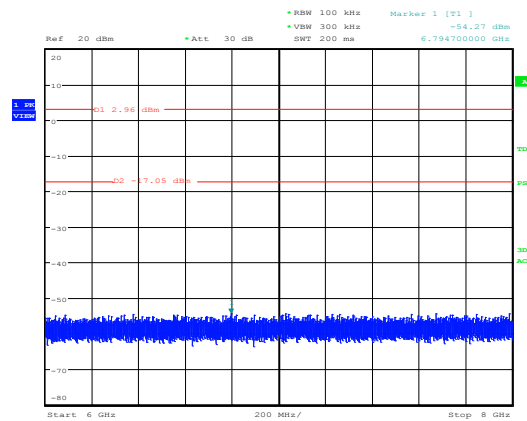

Conducted spurious emissions, mode 11g, A1
Date: 14.JAN.2016 15:23:38

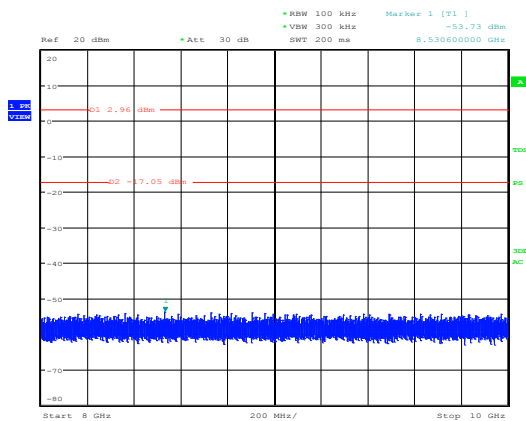

Conducted spurious emissions, mode 11g, A1
Date: 14.JAN.2016 15:24:03

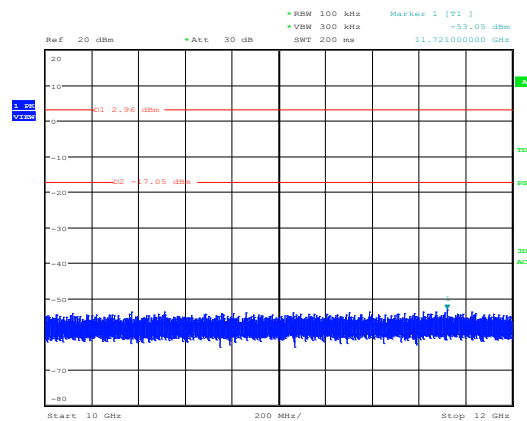

Conducted spurious emissions, mode 11g, A1
Date: 14.JAN.2016 15:24:22

Figure 36: Conducted Spurious Emissions, 12 - 24GHz, Mode A (2412MHz), IEEE 802.11g

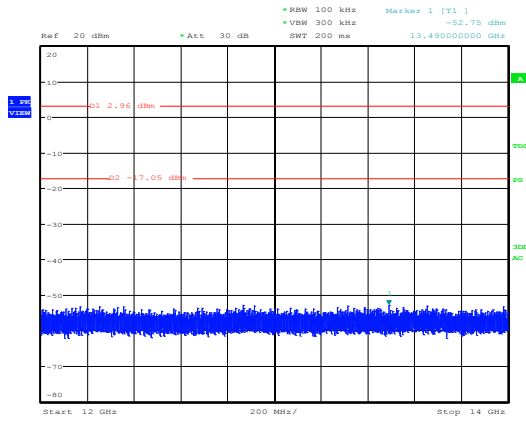

Conducted spurious emissions, mode 11g, A1
 Date: 14.JAN.2016 15:24:42

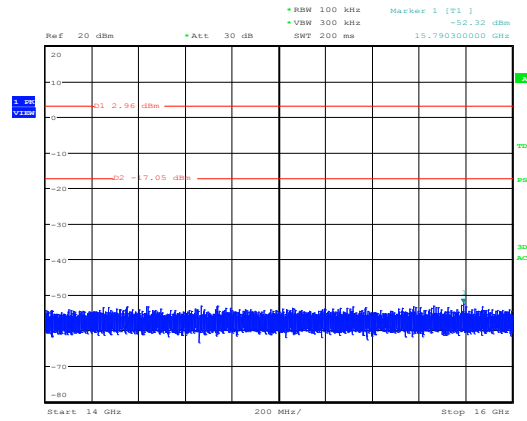

Conducted spurious emissions, mode 11g, A1
 Date: 14.JAN.2016 15:25:03

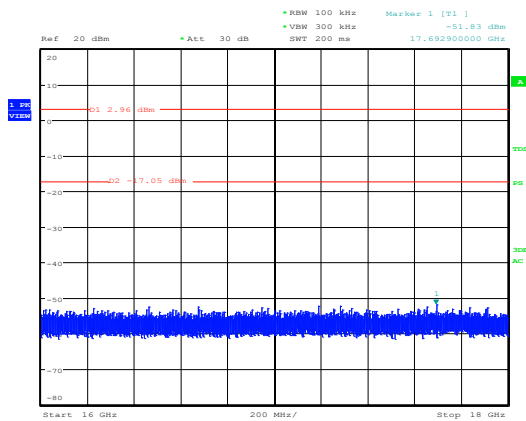

Conducted spurious emissions, mode 11g, A1
 Date: 14.JAN.2016 15:25:47

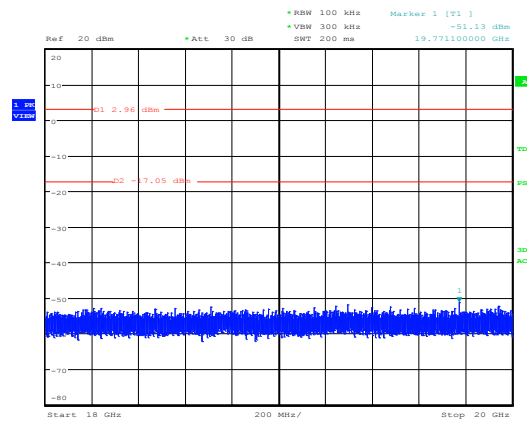

Conducted spurious emissions, mode 11g, A1
 Date: 14.JAN.2016 15:26:22

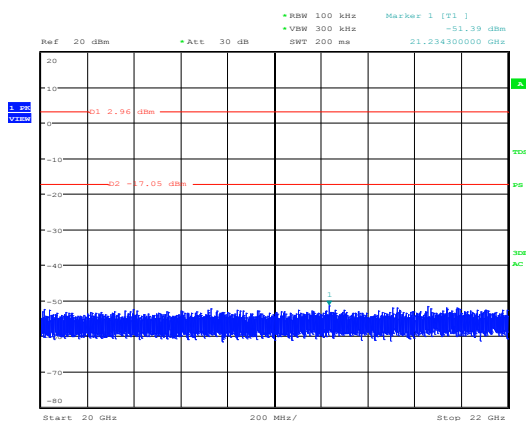

Conducted spurious emissions, mode 11g, A1
 Date: 14.JAN.2016 15:26:45

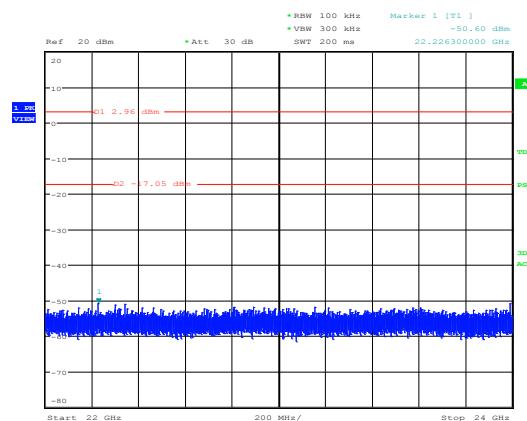

Conducted spurious emissions, mode 11g, A1
 Date: 14.JAN.2016 15:27:07

Produkte
Products

Prüfbericht - Nr.: **50036571 001**
Test Report No.:

Seite 52 von 114
Page 52 of 114

Figure 37: Conducted Spurious Emissions, 24 - 25GHz, Mode A (2412MHz), IEEE 802.11g

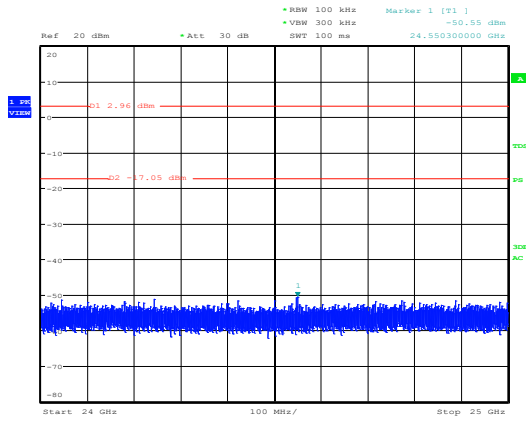

Conducted spurious emissions, mode 11g, A1
Date: 14.JAN.2016 15:27:51

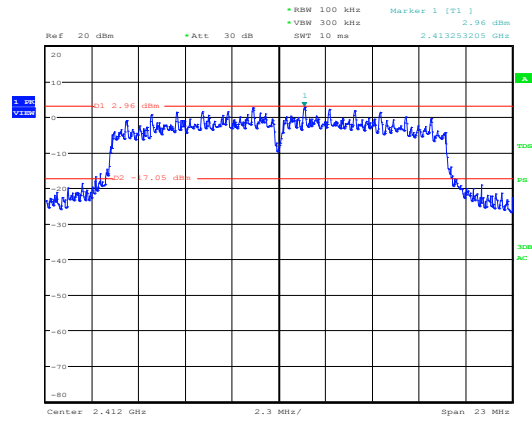

Conducted spurious emissions, mode 11g, A1
Date: 14.JAN.2016 15:22:12

Figure 38: Conducted Spurious Emissions, 30MHz - 12GHz, Mode B (2437MHz), IEEE 802.11g

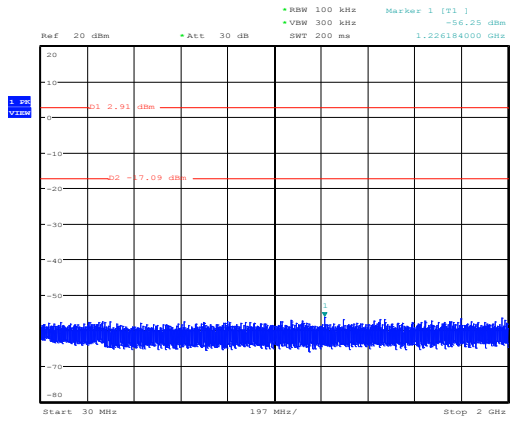

Conducted spurious emissions, mode 11g, B1
 Date: 14.JAN.2016 15:56:43

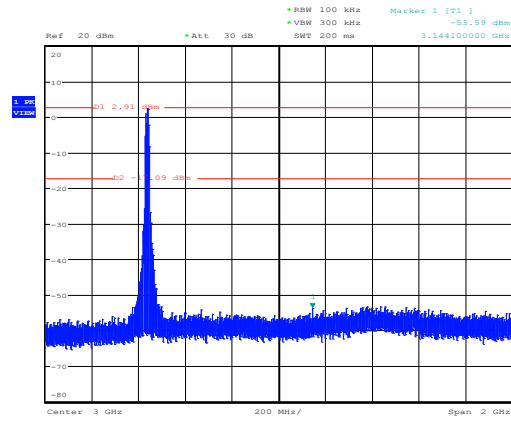

Conducted spurious emissions, mode 11g, B1
 Date: 14.JAN.2016 15:57:29

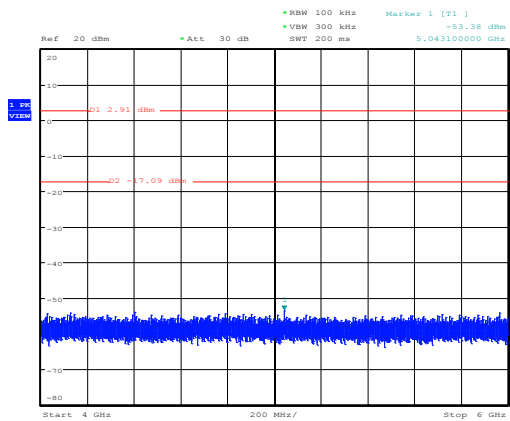

Conducted spurious emissions, mode 11g, B1
 Date: 14.JAN.2016 15:57:57

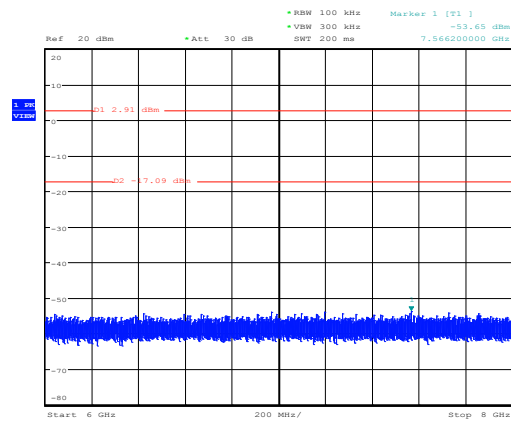

Conducted spurious emissions, mode 11g, B1
 Date: 14.JAN.2016 15:58:36

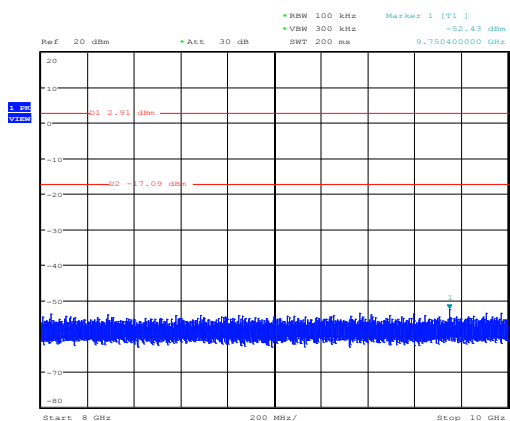

Conducted spurious emissions, mode 11g, B1
 Date: 14.JAN.2016 15:59:14

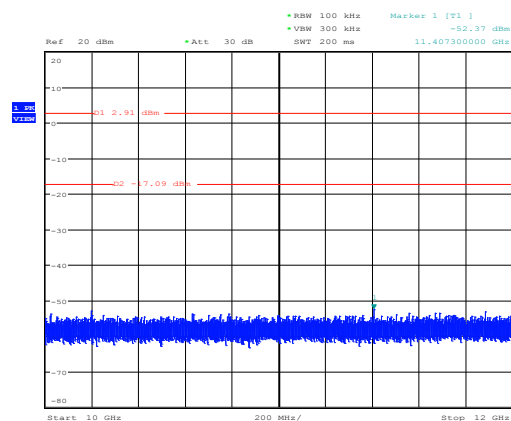

Conducted spurious emissions, mode 11g, B1
 Date: 14.JAN.2016 15:59:41

Figure 39: Conducted Spurious Emissions, 12 - 24GHz, Mode B (2437MHz), IEEE 802.11g

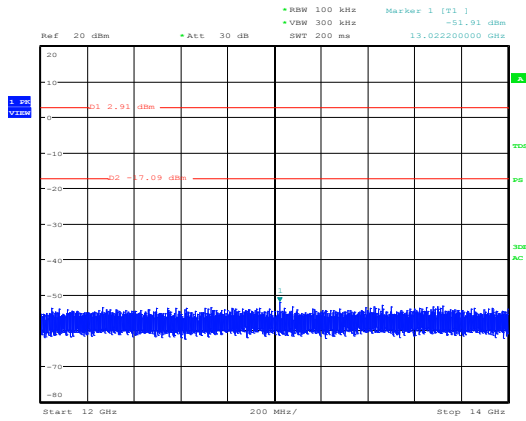

Conducted spurious emissions, mode 11g, B1
Date: 14.JAN.2016 16:00:04

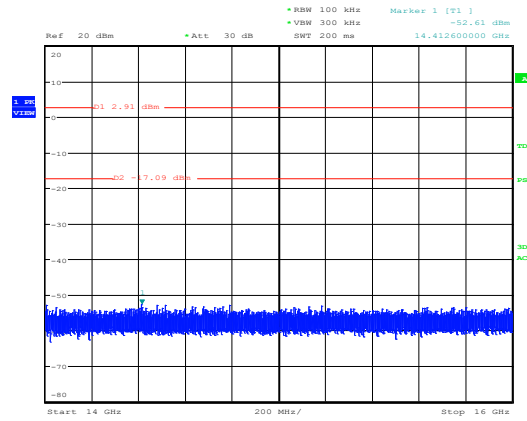

Conducted spurious emissions, mode 11g, B1
Date: 14.JAN.2016 16:00:22

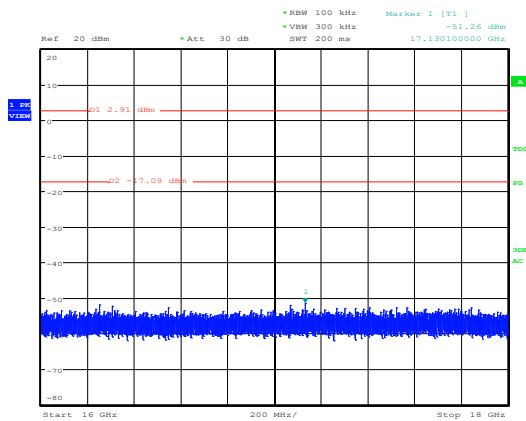

Conducted spurious emissions, mode 11g, B1
Date: 14.JAN.2016 16:00:43

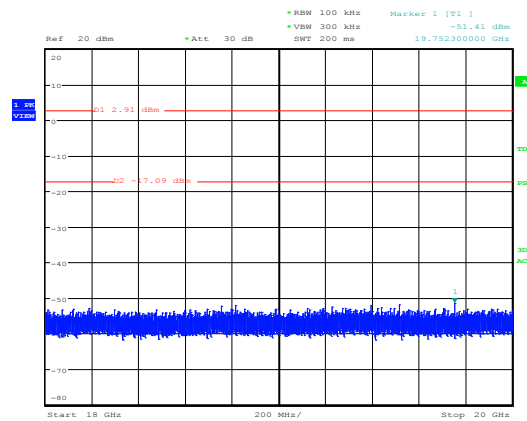

Conducted spurious emissions, mode 11g, B1
Date: 14.JAN.2016 16:01:02

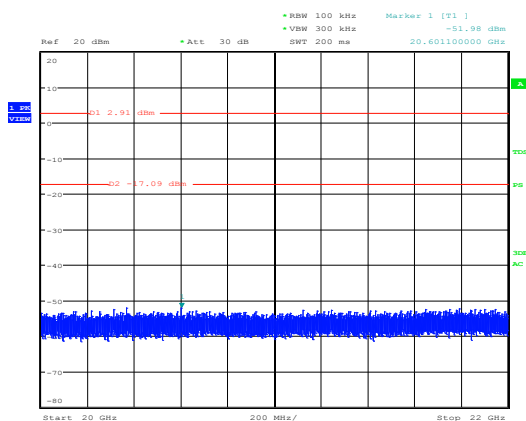

Conducted spurious emissions, mode 11g, B1
Date: 14.JAN.2016 16:01:21

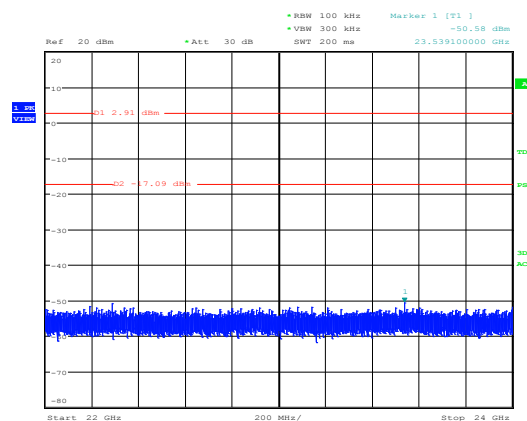

Conducted spurious emissions, mode 11g, B1
Date: 14.JAN.2016 16:01:40

Produkte
Products

Prüfbericht - Nr.: 50036571 001
Test Report No.:

Seite 55 von 114
Page 55 of 114

Figure 40: Conducted Spurious Emissions, 24 - 25GHz, Mode B (2437MHz), IEEE 802.11g

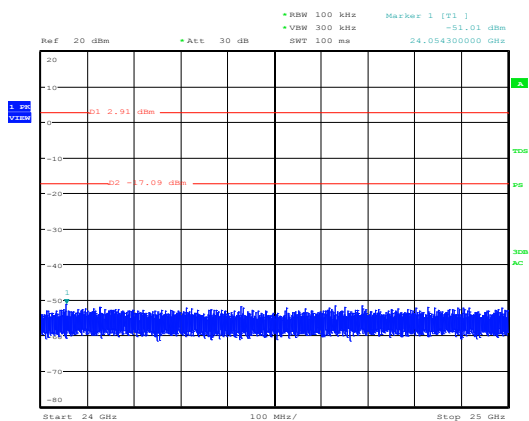

Conducted spurious emissions, mode 11g, B1
Date: 14.JAN.2016 16:02:00

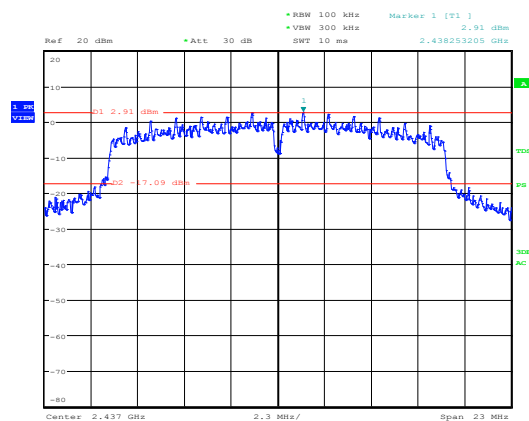

Conducted spurious emissions, mode 11g, B1
Date: 14.JAN.2016 15:56:26

Figure 41: Conducted Spurious Emissions, 30MHz - 12GHz, Mode C (2462MHz), IEEE 802.11g

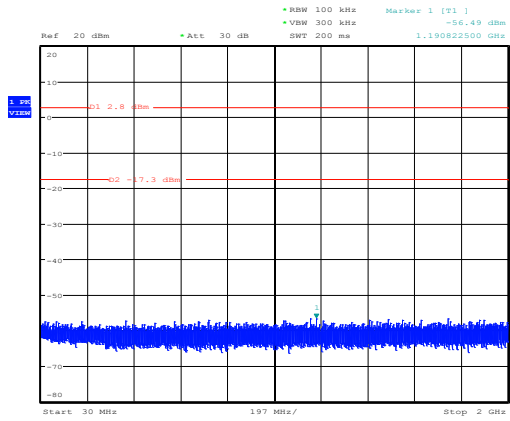

Conducted spurious emissions, mode 11g, C1
 Date: 14.JAN.2016 16:05:44

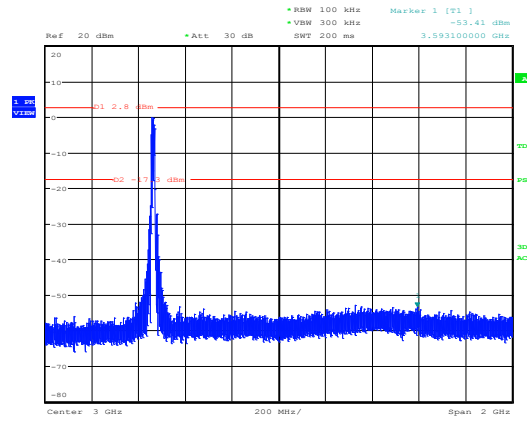

Conducted spurious emissions, mode 11g, C1
 Date: 14.JAN.2016 16:06:35

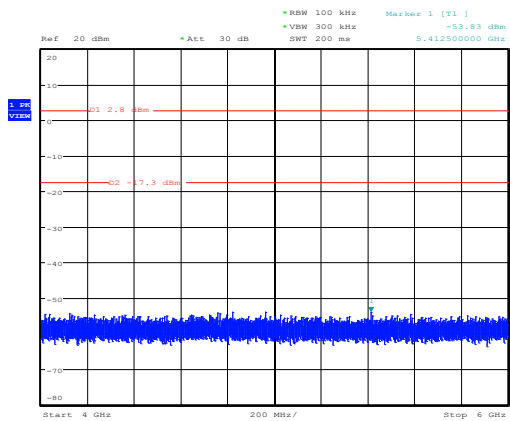

Conducted spurious emissions, mode 11g, C1
 Date: 14.JAN.2016 16:06:56

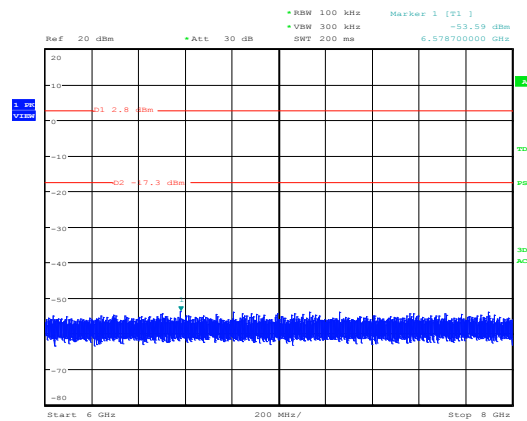

Conducted spurious emissions, mode 11g, C1
 Date: 14.JAN.2016 16:07:16

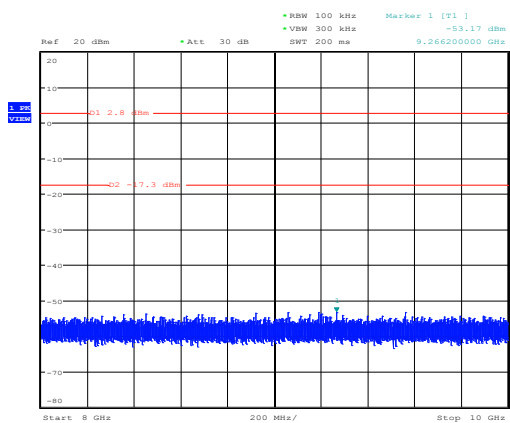

Conducted spurious emissions, mode 11g, C1
 Date: 14.JAN.2016 16:07:36

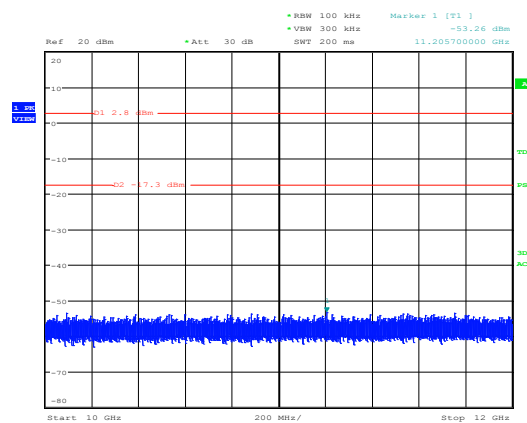

Conducted spurious emissions, mode 11g, C1
 Date: 14.JAN.2016 16:07:54

Figure 42: Conducted Spurious Emissions, 12 - 24GHz, Mode C (2462MHz), IEEE 802.11g

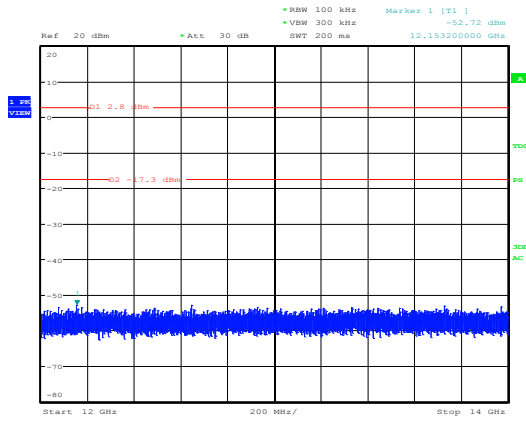

Conducted spurious emissions, mode 11g, C1
Date: 14.JAN.2016 16:08:28

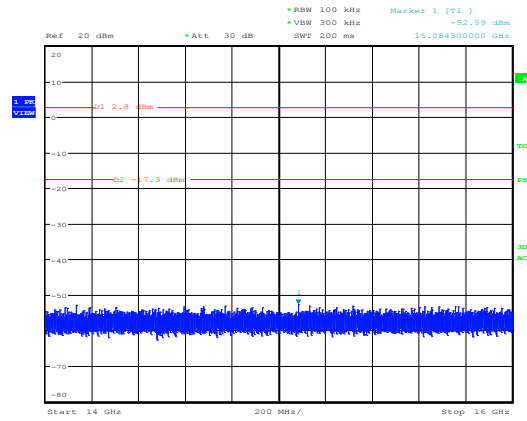

Conducted spurious emissions, mode 11g, C1
Date: 14.JAN.2016 16:08:51

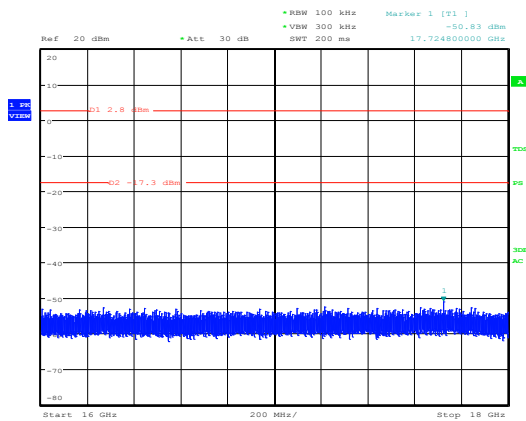

Conducted spurious emissions, mode 11g, C1
Date: 14.JAN.2016 16:09:09

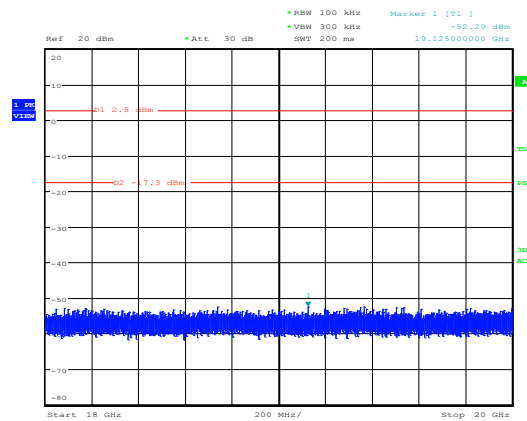

Conducted spurious emissions, mode 11g, C1
Date: 14.JAN.2016 16:09:35

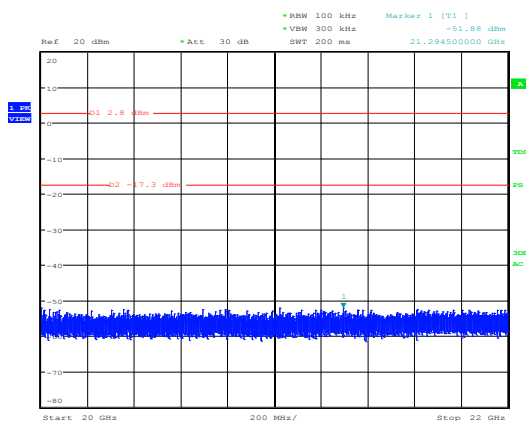

Conducted spurious emissions, mode 11g, C1
Date: 14.JAN.2016 16:10:05

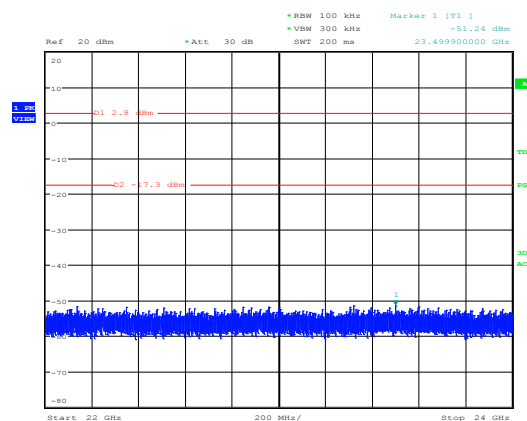

Conducted spurious emissions, mode 11g, C1
Date: 14.JAN.2016 16:10:34

Produkte
Products

Prüfbericht - Nr.: 50036571 001
Test Report No.:

Seite 58 von 114
Page 58 of 114

Figure 43: Conducted Spurious Emissions, 24 - 25GHz, Mode C (2462MHz) IEEE 802.11g

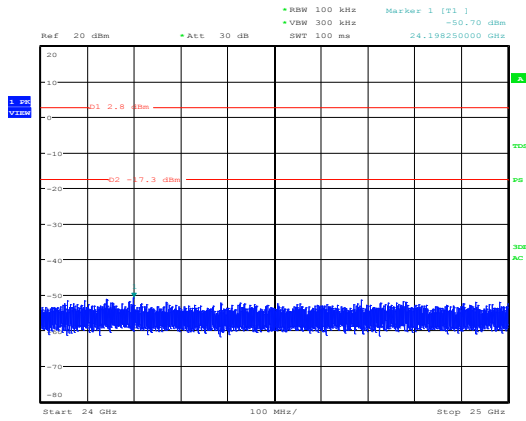

Conducted spurious emissions, mode 11g, C1
Date: 14.JAN.2016 16:11:10

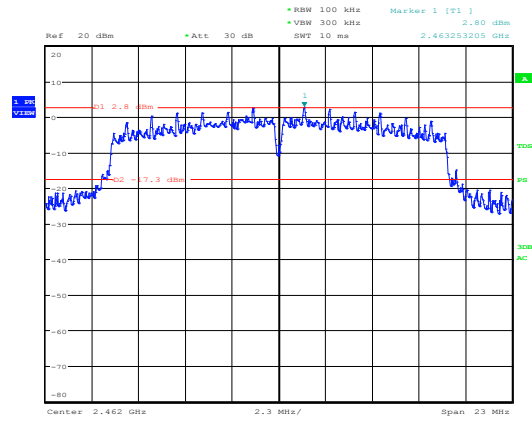

Conducted spurious emissions, mode 11g, C1
Date: 14.JAN.2016 16:05:26