

**FCC 47 CFR PART 15 SUBPART B  
CERTIFICATION TEST REPORT**

**PC VR Headset**

**MODEL No.: V9S**

**Trade Mark: VIULUX**

**FCC ID: 2AGQ9-VIULUXV9S**

**REPORT NO: ES171215994W**

**ISSUE DATE: January 03, 2018**

*Prepared for*

**Inlife-handnet Co., Ltd  
53rd Floor, CES Tower, No.3099 Keyuan South Road, Yuehai Street,  
Nanshan District, Shenzhen City, Guangdong Province, P.R.C**

*Prepared by*

**EMTEK (SHENZHEN) CO., LTD.**

**Bldg 69, Majialong Industry Zone, Nanshan District, Shenzhen,  
Guangdong, China  
TEL: 86-755-26954280  
FAX: 86-755-26954282**

## TABLE OF CONTENT

Test Report Description	Page
<b>1. SUMMARY OF TEST RESULT .....</b>	<b>5</b>
<b>2. GENERAL INFORMATION .....</b>	<b>6</b>
2.1. DESCRIPTION OF DEVICE (EUT) .....	6
2.2. DESCRIPTION OF TEST FACILITY .....	6
2.3. DESCRIPTION OF SUPPORT DEVICE .....	7
2.4. MEASUREMENT UNCERTAINTY .....	7
<b>3. MEASURING DEVICE AND TEST EQUIPMENT .....</b>	<b>8</b>
3.1. FOR POWER LINE CONDUCTED EMISSION MEASUREMENT .....	8
3.2. FOR RADIATED EMISSION MEASUREMENT (3M CHAMBER).....	8
<b>4. CONDUCTED EMISSION MEASUREMENT .....</b>	<b>9</b>
4.1. BLOCK DIAGRAM OF TEST SETUP .....	9
4.2. MEASURING STANDARD.....	9
4.3. POWER LINE CONDUCTED EMISSION LIMITS (CLASS B) .....	9
4.4. EUT CONFIGURATION ON MEASUREMENT .....	9
4.5. OPERATING CONDITION OF EUT .....	9
4.6. TEST PROCEDURE .....	10
4.7. MEASURING RESULTS .....	10
<b>5. RADIATED EMISSION MEASUREMENT.....</b>	<b>13</b>
5.1. BLOCK DIAGRAM OF TEST SETUP .....	13
5.2. MEASURING STANDARD.....	14
5.3. RADIATED EMISSION LIMITS (CLASS B) .....	14
5.4. EUT CONFIGURATION ON MEASUREMENT .....	14
5.5. OPERATING CONDITION OF EUT .....	14
5.6. TEST PROCEDURE .....	14
5.7. MEASURING RESULTS .....	15
<b>6. PHOTOGRAPHS .....</b>	<b>20</b>
6.1. PHOTOS OF CONDUCTED EMISSION MEASUREMENT .....	20
6.2. PHOTOS OF RADIATION EMISSION MEASUREMENT .....	21

## TEST REPORT DESCRIPTION

Applicant : Inlife-handnet Co., Ltd  
53rd Floor,CES Tower, No.3099 Keyuan South Road, Yuehai Street,  
Nanshan District, Shenzhen City, Guangdong Province, P.R.C

Manufacturer : Inlife-handnet Co., Ltd  
53rd Floor,CES Tower, No.3099 Keyuan South Road, Yuehai Street,  
Nanshan District, Shenzhen City, Guangdong Province, P.R.C

Trademark : VIULUX

EUT : PC VR Headset

Model No. : V9S

Power Supply : DC 5V from PC

### Measurement Procedure Used:

FCC Rules and Regulations Part 15: 2017 Subpart B Class B & FCC / ANSI C63.4-2014

The device described above is tested by EMTEK (SHENZHEN) CO., LTD. to determine the maximum emission levels emanating from the device and the severe levels of the device can endure and its performance criterion. The measurement results are contained in this test report and EMTEK (SHENZHEN) CO., LTD. is assumed full of responsibility for the accuracy and completeness of these measurements. Also, this report shows that the EUT (Equipment Under Test) is technically compliant with the FCC requirements.

This report applies to above tested sample only and shall not be reproduced in part without written approval of EMTEK (SHENZHEN) CO., LTD.

Date of Test : December 15, 2017 to January 02, 2018

Prepared by :   
Doris Su/Editor

Reviewer :   
Yaping Shen /Supervisor

Approved & Authorized Signer :   
Lisa Wang/Manager



### Modified Information

Version	Report No.	Revision Date	Summary
Ver.1.0	ES171215994W	/	Original Report

## 1. SUMMARY OF TEST RESULT

<b>EMISSION</b>		
Description of Test Item	Standard & Limits	Results
Conducted Disturbance at Mains Terminals	FCC Part 15, Subpart B, Class B ANSI C63.4: 2014	Pass
Radiated Disturbance	FCC Part 15, Subpart B, Class B ANSI C63.4: 2014	Pass
Note: N/A is an abbreviation for Not Applicable.		

## 2. GENERAL INFORMATION

### 2.1. Description of Device (EUT)

EUT : PC VR Headset

Model Number : V9S

Test Voltage : DC 5V from PC

Applicant : Inlife-handnet Co., Ltd

Address : 53rd Floor, CES Tower, No.3099 Keyuan South Road, Yuehai Street,  
Nanshan District, Shenzhen City, Guangdong Province, P.R.C

Manufacturer : Inlife-handnet Co., Ltd

Address : 53rd Floor, CES Tower, No.3099 Keyuan South Road, Yuehai Street,  
Nanshan District, Shenzhen City, Guangdong Province, P.R.C

Date of Received : December 15, 2017

Date of Test : December 15, 2017 to January 02, 2018

### 2.2. Description of Test Facility

Site Description  
EMC Lab. : Accredited by CNAS, 2016.10.24  
The certificate is valid until 2016.10.28  
The Laboratory has been assessed and proved to be in compliance with  
CNAS-CL01:2006 (identical to ISO/IEC 17025:2005)  
The Certificate Registration Number is L2291.

Accredited by TUV Rheinland Shenzhen 2016.5.19  
The Laboratory has been assessed according to the requirements  
ISO/IEC 17025.

Accredited by FCC, August 03, 2017  
Designation Number: CN1204  
Test Firm Registration Number: 882943

Accredited by Industry Canada, November 24, 2015  
The Certificate Registration Number is 4480A.

Name of Firm : EMTEK (SHENZHEN) CO., LTD.  
Site Location : Bldg 69, Majialong Industry Zone,  
Nanshan District, Shenzhen, Guangdong, China

### 2.3. Description of Support Device

PC	:	Manufacturer: LENOVO M/N: ThinkCentre 8701 S/N: 8701A53L3BC108 CE, FCC
LCD Monitor	:	Manufacturer: LENOVO M/N: 9227-AE6 S/N:4M0293084302824 CE, FCC
Keyboard	:	Manufacturer: LENOVO M/N: KU-0225 S/N:0585494 CE, FCC: DOC
Mouse	:	Manufacturer: LENOVO M/N: MO28UOL S/N:44G7862 068 CE, FCC: DOC

### 2.4. Measurement Uncertainty

Test Item	Uncertainty
Conducted Emission Uncertainty	: 2.96dB(9k~150kHz Conduction 1#)
	2.74dB(150k-30MHz Conduction 1#)
Radiated Emission Uncertainty (3m Chamber)	: 3.78dB (30M~1GHz Polarize: H)
	4.27dB (30M~1GHz Polarize: V)
	4.46dB (1~6GHz)

### 3. MEASURING DEVICE AND TEST EQUIPMENT

#### 3.1. For Power Line Conducted Emission Measurement

Item	Equipment	Manufacturer	Model No.	Serial No.	Last Cal.	Cal. Interval
<input checked="" type="checkbox"/>	Test Receiver	Rohde & Schwarz	ESCI	26115-010-0027	May 20, 2017	1 Year
<input checked="" type="checkbox"/>	L.I.S.N.	Rohde & Schwarz	ENV216	101161	May 20, 2017	1 Year
<input checked="" type="checkbox"/>	50Ω Coaxial Switch	Anritsu	MP59B	6100175589	May 21, 2017	1 Year
<input checked="" type="checkbox"/>	Voltage Probe	Rohde & Schwarz	ESH2-Z3	100122	May 21, 2017	1 Year

#### 3.2. For Radiated Emission Measurement (3m Chamber)

Item	Equipment	Manufacturer	Model No.	Serial No.	Last Cal.	Cal. Interval
<input checked="" type="checkbox"/>	EMI Test Receiver	Rohde & Schwarz	ESU	1302.6005.26	May 21, 2017	1 Year
<input checked="" type="checkbox"/>	Pre-Amplifier	HP	8447F	2944A07999	May 20, 2017	1 Year
<input checked="" type="checkbox"/>	Bilog Antenna	Schwarzbeck	VULB9163	142	May 20, 2017	1 Year
<input checked="" type="checkbox"/>	Cable	Schwarzbeck	AK9513	ACRX1	May 21, 2017	1 Year
<input checked="" type="checkbox"/>	Cable	Rosenberger	N/A	FP2RX2	May 21, 2017	1 Year
<input checked="" type="checkbox"/>	Cable	Schwarzbeck	AK9513	CRPX1	May 21, 2017	1 Year
<input checked="" type="checkbox"/>	Cable	Schwarzbeck	AK9513	CRRX2	May 21, 2017	1 Year
<input checked="" type="checkbox"/>	EMI Test Receiver	Rohde & Schwarz	ESU	1302.6005.26	May 21, 2017	1 Year
<input checked="" type="checkbox"/>	Pre-Amplifier	A.H.	PAM-0126	1415261	May 20, 2017	1 Year
<input checked="" type="checkbox"/>	Horn Antenna	Schwarzbeck	BBHA 9120	707	May 20, 2017	1 Year
<input checked="" type="checkbox"/>	Cable	H+B	0.5M SF104-26.5	289147/4	May 21, 2017	1 Year
<input checked="" type="checkbox"/>	Cable	H+B	3M SF104-26.5	295838/4	May 21, 2017	1 Year
<input checked="" type="checkbox"/>	Cable	H+B	6M SF104-26.5	295840/4	May 21, 2017	1 Year



## 4. CONDUCTED EMISSION MEASUREMENT

### 4.1. Block Diagram of Test Setup

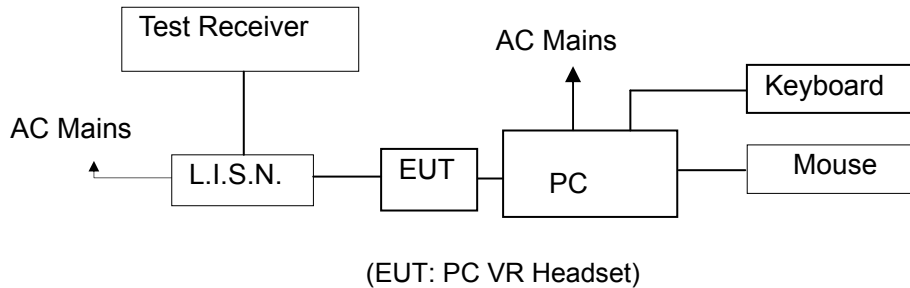

### 4.2. Measuring Standard

FCC Part 15, Subpart B, Class B ANSI C63.4: 2014

### 4.3. Power Line Conducted Emission Limits (Class B)

Frequency (MHz)	Limit (dB $\mu$ V)	
	Quasi-peak Level	Average Level
0.15 ~ 0.50	66.0 ~ 56.0 *	56.0 ~ 46.0 *
0.50 ~ 5.00	56.0	46.0
5.00 ~ 30.00	60.0	50.0

NOTE1-The lower limit shall apply at the transition frequencies.  
NOTE2-The limit decreases linearly with the logarithm of the frequency in the range 0.15MHz to 0.50MHz.

### 4.4. EUT Configuration on Measurement

The following equipments are installed on Conducted Emission Measurement to meet FCC requirements and operating in a manner which tends to maximize its emission characteristics in a normal application.

EUT : PC VR Headset  
Model Number : V9S

### 4.5. Operating Condition of EUT

- 4.5.1. Setup the EUT as shown on Section 4.1.
- 4.5.2. Turn on the power of all equipments.
- 4.5.3. Let the EUT work in measuring mode (Connect to PC) and measure it.

#### 4.6. Test Procedure

The EUT is put on the plane 0.8m high above the ground by insulating support and connected to the AC mains through Line Impedance Stability Network (L.I.S.N). This provided a 50ohm coupling impedance for the tested equipments. Both sides of AC line are investigated to find out the maximum conducted emission according to the FCC regulations during conducted emission measurement.

The bandwidth of the field strength meter (R&S Test Receiver ESCS30) is set at 9kHz in 150kHz~30MHz and 200Hz in 9kHz~150kHz.

The frequency range from 150kHz to 30MHz is investigated.

All the modes were tested and the data of the worst modes are attached the following pages.

#### 4.7. Measuring Results

**PASS.**

Please refer to the following pages.

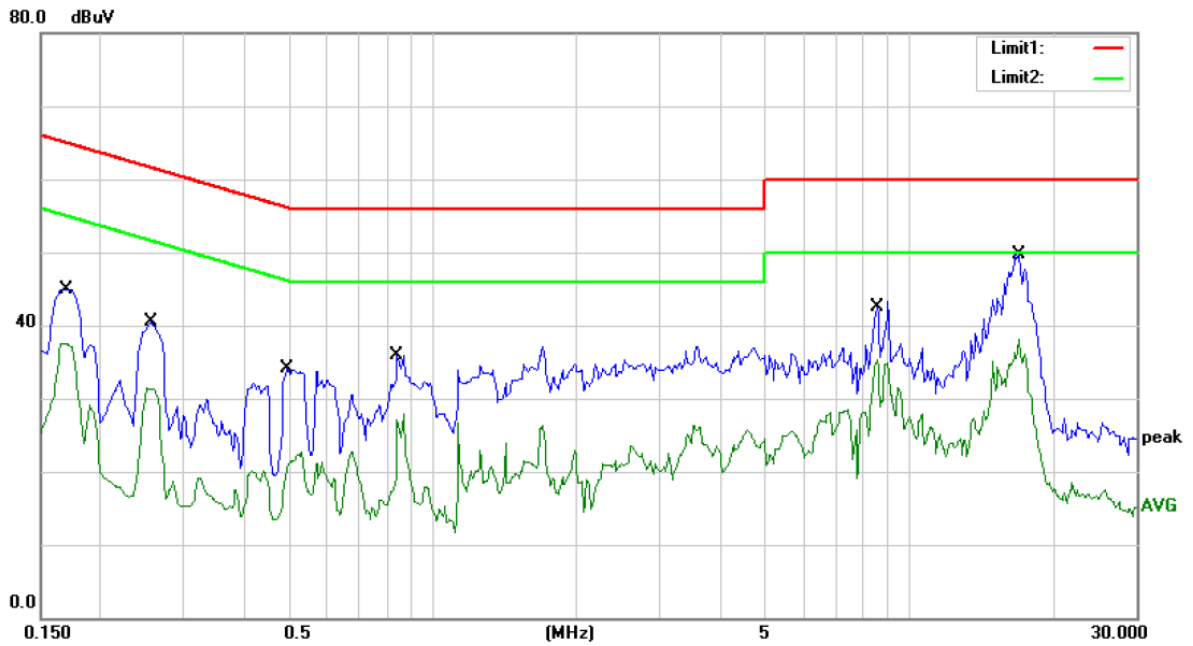

Site Conduction #1

Phase: **L1**

Temperature: 22

Limit: (CE)FCC PART 15 class B\_QP

Power: AC 120V/60Hz

Humidity: 55 %

Mode: connect to PC

Note:

No.	Mk.	Freq. MHz	Reading Level dBuV	Correct Factor dB	Measure- ment dBuV	Limit dBuV	Over dB	Detector	Comment
1		0.1700	44.95	0.00	44.95	64.96	-20.01	QP	
2		0.1700	37.50	0.00	37.50	54.96	-17.46	AVG	
3		0.2550	40.51	0.00	40.51	61.59	-21.08	QP	
4		0.2550	31.43	0.00	31.43	51.59	-20.16	AVG	
5		0.4950	34.10	0.00	34.10	56.08	-21.98	QP	
6		0.4950	22.77	0.00	22.77	46.08	-23.31	AVG	
7		0.8400	35.97	0.00	35.97	56.00	-20.03	QP	
8		0.8400	27.88	0.00	27.88	46.00	-18.12	AVG	
9		8.5750	42.43	0.00	42.43	60.00	-17.57	QP	
10		8.5750	35.34	0.00	35.34	50.00	-14.66	AVG	
11	*	17.0000	49.75	0.00	49.75	60.00	-10.25	QP	
12		17.0000	38.05	0.00	38.05	50.00	-11.95	AVG	

\*:Maximum data    x:Over limit    !:over margin    Comment: Factor build in receiver.    Operator:

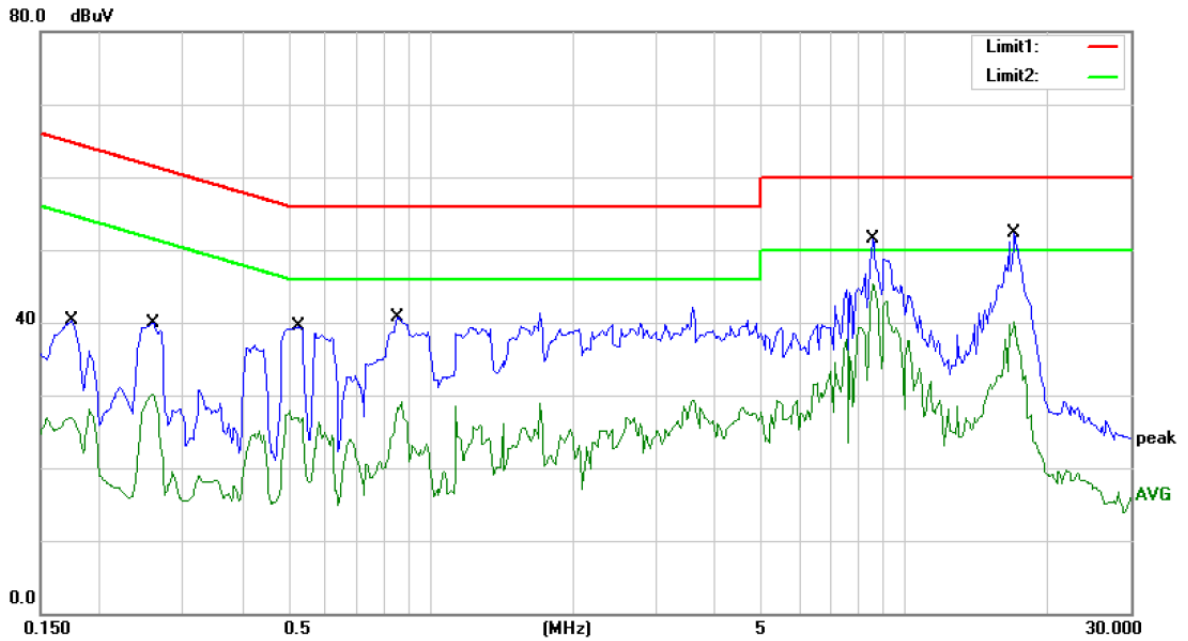

Site Conduction #1 Phase: **N** Temperature: 22  
 Limit: (CE)FCC PART 15 class B\_QP Power: AC 120V/60Hz Humidity: 55 %  
 Mode: connect to PC  
 Note:

No.	Mk.	Freq.	Reading Level	Correct Factor	Measurement	Limit	Over	Detector	Comment
		MHz	dBuV	dB	dBuV	dBuV	dB		
1		0.1750	40.29	0.00	40.29	64.72	-24.43	QP	
2		0.1750	26.90	0.00	26.90	54.72	-27.82	AVG	
3		0.2600	39.98	0.00	39.98	61.43	-21.45	QP	
4		0.2600	30.09	0.00	30.09	51.43	-21.34	AVG	
5		0.5250	39.44	0.00	39.44	56.00	-16.56	QP	
6		0.5250	27.90	0.00	27.90	46.00	-18.10	AVG	
7		0.8500	40.80	0.00	40.80	56.00	-15.20	QP	
8		0.8500	29.14	0.00	29.14	46.00	-16.86	AVG	
9		8.5750	51.43	0.00	51.43	60.00	-8.57	QP	
10	*	8.5750	45.25	0.00	45.25	50.00	-4.75	AVG	
11		17.0500	52.31	0.00	52.31	60.00	-7.69	QP	
12		17.0500	40.13	0.00	40.13	50.00	-9.87	AVG	

\*:Maximum data    x:Over limit    !:over margin    Comment: Factor build in receiver.    Operator:

## 5. RADIATED EMISSION MEASUREMENT

### 5.1. Block Diagram of Test Setup

#### 5.1.1. Block diagram of EUT System

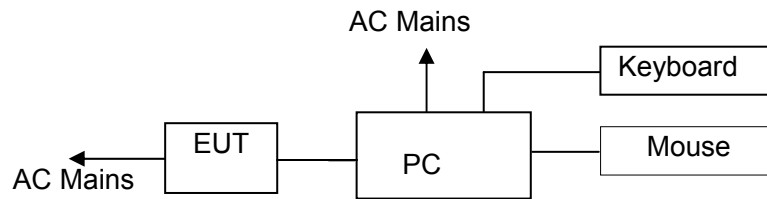

(EUT: PC VR Headset)

#### 5.1.2. Block diagram of test setup (In chamber)

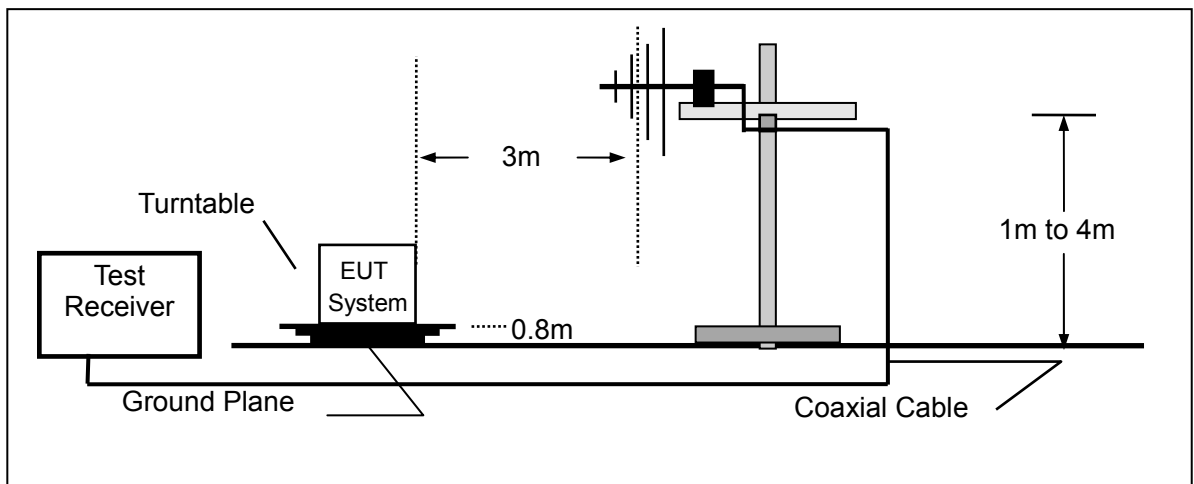

(EUT: PC VR Headset)

## 5.2. Measuring Standard

FCC Part 15, Subpart B, Class B ANSI C63.4: 2014

## 5.3. Radiated Emission Limits (Class B)

Frequency MHz	Distance (Meters)	Field Strengths Limit		
		$\mu\text{V/m}$ @3m	$\mu\text{V/m}$ @10m	$\text{dB}(\mu\text{V})/\text{m}@10\text{M}$
30 ~ 88	10	100	30	29.5
88 ~ 216	10	150	45	33.0
216 ~ 960	10	200	60	35.5
960 ~ 1000	10	500	150	43.5

Frequency (GHz)	Distance (Meters)	Field Strengths Limit	
		Average ( $\text{dB}\mu\text{V}/\text{m}$ )	Peak ( $\text{dB}\mu\text{V}/\text{m}$ )
1~6	3	54	74

Remark: (1) Emission level  $(\text{dB})\mu\text{V} = 20 \log$  Emission level  $\mu\text{V}/\text{m}$   
 (2)  $(\text{Emission level } \mu\text{V}/\text{m} @3\text{m}) / (\text{Emission level } \mu\text{V}/\text{m} @10\text{m}) = 10\text{m} / 3\text{m}$   
 (3) The smaller limit shall apply at the cross point between two frequency bands.  
 (4) Distance is the distance in meters between the measuring instrument, antenna and the closest point of any part of the device or system.

## 5.4. EUT Configuration on Measurement

The FCC Class B regulations test method must be used to find the maximum emission during radiated emission measurement.

EUT : PC VR Headset  
 Model Number : V9S

## 5.5. Operating Condition of EUT

5.5.1. Setup the EUT as shown on Section 5.1.

5.5.2. Turn on the power of all equipments.

5.5.3. Let the EUT work in measuring mode (Connect to PC) and measure it.

## 5.6. Test Procedure

The EUT is placed on a turn table which is 0.8 meter high above the ground. The turn table can rotate 360 degrees to determine the position of the maximum emission level. The EUT is set 3 meters away from the receiving antenna which is mounted on an antenna tower. The antenna can be moved up and down from 1 to 4 meters to find out the maximum emission level. Bilog antenna (calibrated by Dipole Antenna) is used as a receiving antenna. Both horizontal and vertical polarization of the antenna are set on test.

The bandwidth of the Receiver (ESU26) is set at 120kHz.

All the modes were tested and the data of the worst modes are attached the following pages.

## 5.7. Measuring Results

**PASS.**

The frequency range from 30MHz to 6000MHz is investigated.

Please refer to the following pages.

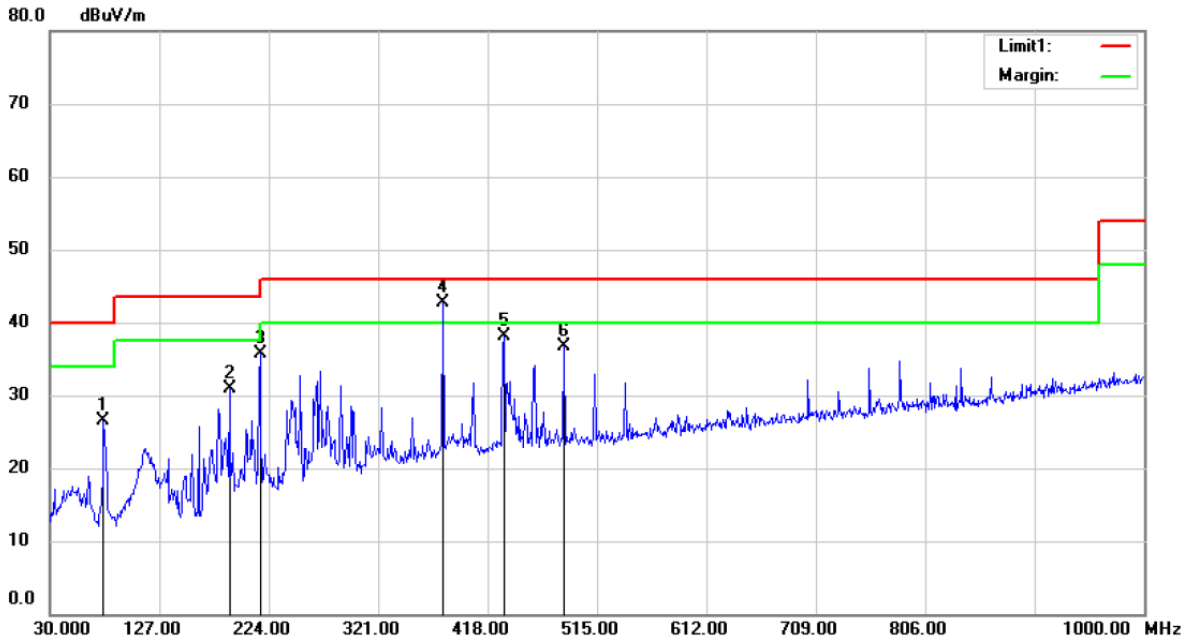

Site 3m Chamber #1      Polarization: **Horizontal**      Temperature: 22 C  
 Limit: (RE)FCC PART 15 CLASS B      Power: AC 120V/60Hz      Humidity: 50 %  
 Mode: connect to pc  
 Note:

No.	Mk.	Freq.	Reading Level	Correct Factor	Measurement	Limit	Over	Antenna Height	Table Degree	
		MHz	dBuV	dB	dBuV/m	dBuV/m	dB	cm	degree	Comment
1		77.5300	43.71	-17.13	26.58	40.00	-13.42	QP		
2		189.0800	44.25	-13.37	30.88	43.50	-12.62	QP		
3		216.2400	47.82	-12.20	35.62	46.00	-10.38	QP		
4	*	378.2300	49.72	-7.11	42.61	46.00	-3.39	QP		
5		432.5500	44.31	-6.18	38.13	46.00	-7.87	QP		
6		485.9000	42.22	-5.49	36.73	46.00	-9.27	QP		

\*:Maximum data    x:Over limit    !:over margin

Operator: KK



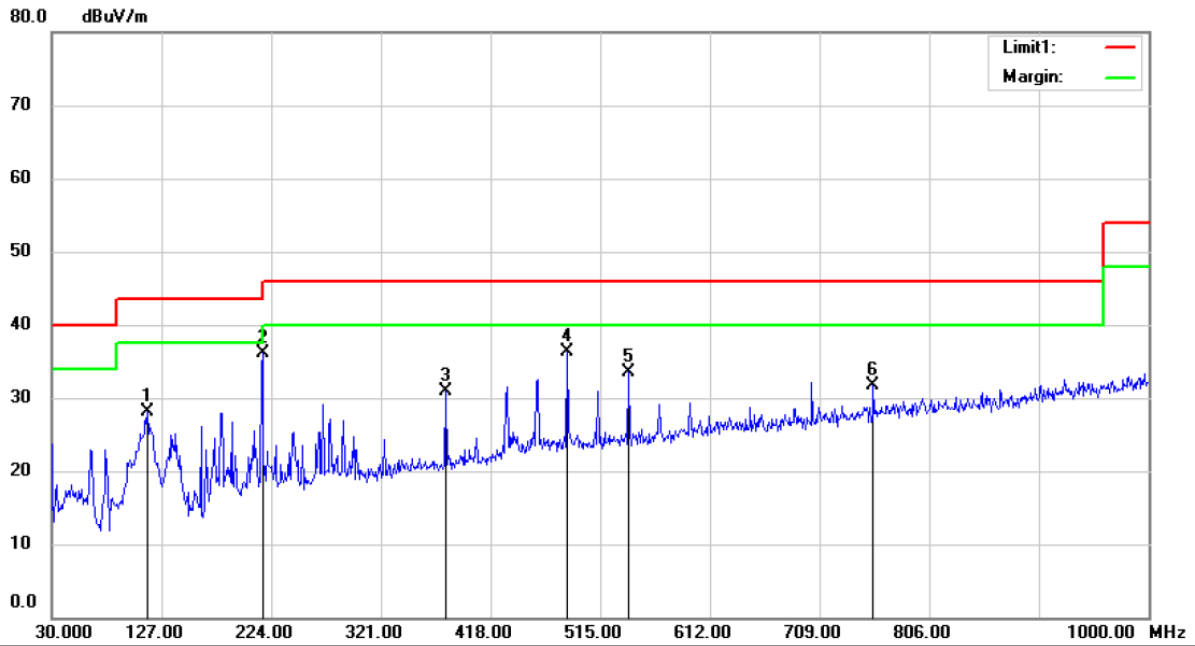

Site 3m Chamber #1      Polarization: **Vertical**      Temperature: 22 C  
 Limit: (RE)FCC PART 15 CLASS B      Power: AC 120V/60Hz      Humidity: 50 %  
 Mode:connect to pc  
 Note:

No.	Mk.	Freq.	Reading Level	Correct Factor	Measurement	Limit	Over	Antenna Height	Table Degree	
		MHz	dBuV	dB	dBuV/m	dBuV/m	dB	cm	degree	Comment
1		114.3900	41.70	-13.63	28.07	43.50	-15.43	QP		
2		216.2400	48.24	-12.20	36.04	46.00	-9.96	QP		
3		378.2300	37.94	-7.11	30.83	46.00	-15.17	QP		
4	*	485.9000	41.87	-5.49	36.38	46.00	-9.62	QP		
5		540.2200	38.15	-4.57	33.58	46.00	-12.42	QP		
6		756.5300	32.79	-1.08	31.71	46.00	-14.29	QP		

\*:Maximum data    x:Over limit    !:over margin

Operator: KK

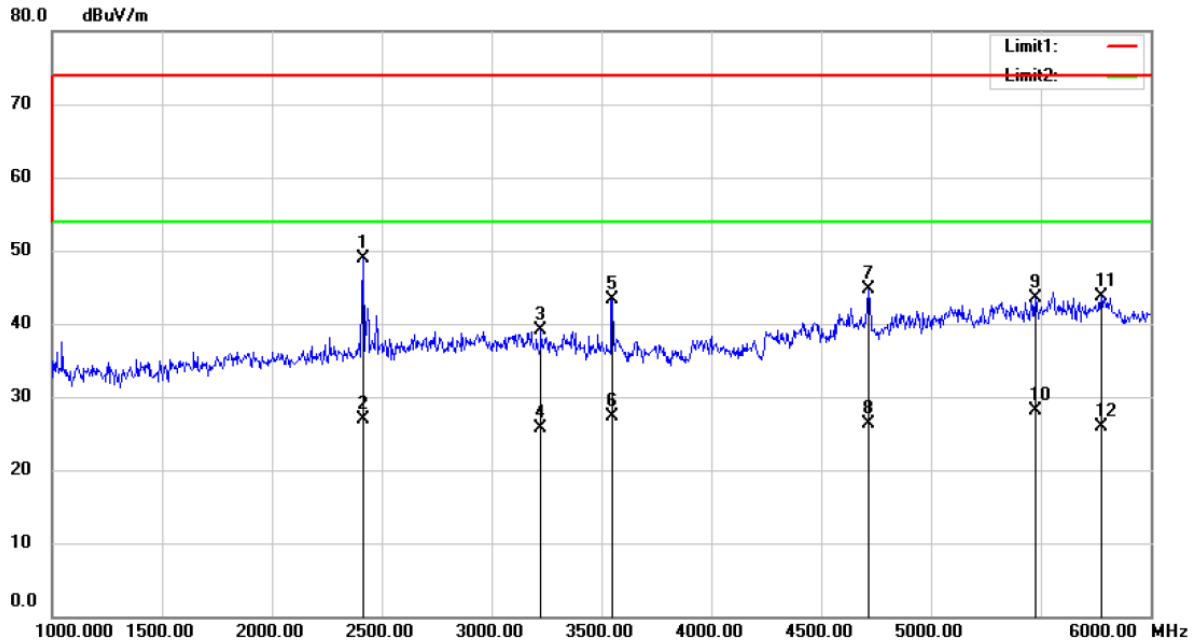

Site 3m Chamber #1      Polarization: **Horizontal**      Temperature: 22 C  
 Limit: (RE)FCC PART 15 CLASS B      Power: AC 120V/60Hz      Humidity: 50 %  
 Mode:connect to pc  
 Note:

No.	Mk.	Freq.	Reading Level	Correct Factor	Measurement	Limit	Over	Antenna Height	Table Degree	
		MHz	dBuV	dB	dBuV/m	dBuV/m	dB	cm	degree	Comment
1	*	2415.000	62.77	-13.85	48.92	74.00	-25.08			peak
2		2415.000	40.75	-13.85	26.90	54.00	-27.10			AVG
3		3225.000	50.83	-11.64	39.19	74.00	-34.81			peak
4		3225.000	37.44	-11.64	25.80	54.00	-28.20			AVG
5		3550.000	54.51	-11.25	43.26	74.00	-30.74			peak
6		3550.000	38.55	-11.25	27.30	54.00	-26.70			AVG
7		4715.000	51.97	-7.30	44.67	74.00	-29.33			peak
8		4715.000	33.70	-7.30	26.40	54.00	-27.60			AVG
9		5475.000	48.82	-5.30	43.52	74.00	-30.48			peak
10		5475.000	33.40	-5.30	28.10	54.00	-25.90			AVG
11		5775.000	48.77	-5.08	43.69	74.00	-30.31			peak
12		5775.000	30.98	-5.08	25.90	54.00	-28.10			AVG

\*:Maximum data    x:Over limit    !:over margin

Operator: KK

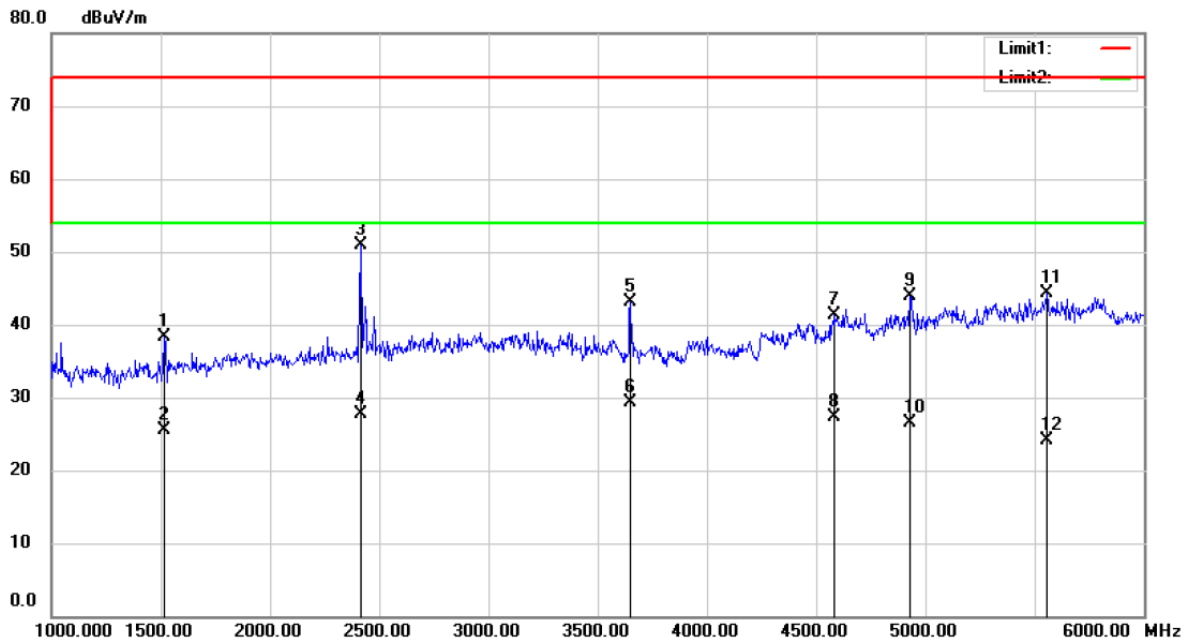

Site 3m Chamber #1      Polarization: **Vertical**      Temperature: 22 C  
 Limit: (RE)FCC PART 15 CLASS B      Power: AC 120V/60Hz      Humidity: 50 %  
 Mode: connect to pc  
 Note:

No.	Mk.	Freq.	Reading Level	Correct Factor	Measurement	Limit	Over	Antenna Height	Table Degree	
		MHz	dBuV	dB	dBuV/m	dBuV/m	dB	cm	degree	Comment
1		1515.000	54.10	-15.78	38.32	74.00	-35.68			peak
2		1515.000	41.38	-15.78	25.60	54.00	-28.40			AVG
3	*	2415.000	64.77	-13.85	50.92	74.00	-23.08			peak
4		2415.000	41.65	-13.85	27.80	54.00	-26.20			AVG
5		3650.000	53.92	-10.88	43.04	74.00	-30.96			peak
6		3650.000	40.28	-10.88	29.40	54.00	-24.60			AVG
7		4585.000	48.82	-7.48	41.34	74.00	-32.66			peak
8		4585.000	34.78	-7.48	27.30	54.00	-26.70			AVG
9		4930.000	50.88	-7.02	43.86	74.00	-30.14			peak
10		4930.000	33.52	-7.02	26.50	54.00	-27.50			AVG
11		5555.000	49.40	-5.18	44.22	74.00	-29.78			peak
12		5555.000	29.28	-5.18	24.10	54.00	-29.90			AVG

\*:Maximum data    x:Over limit    !:over margin

Operator: KK

## 6. PHOTOGRAPHS

### 6.1. Photos of Conducted Emission Measurement



## 6.2. Photos of Radiation Emission Measurement

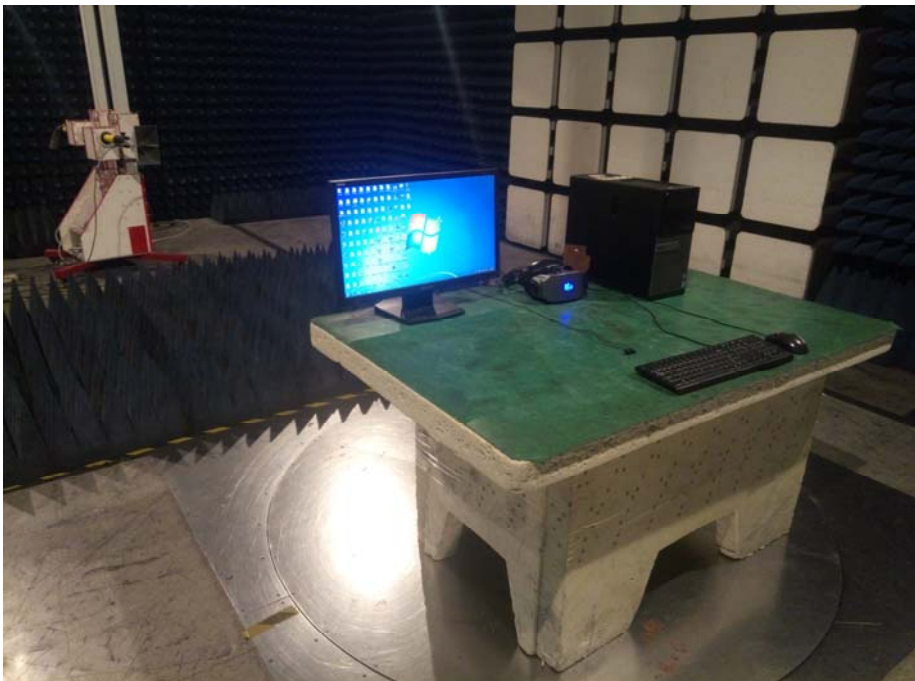
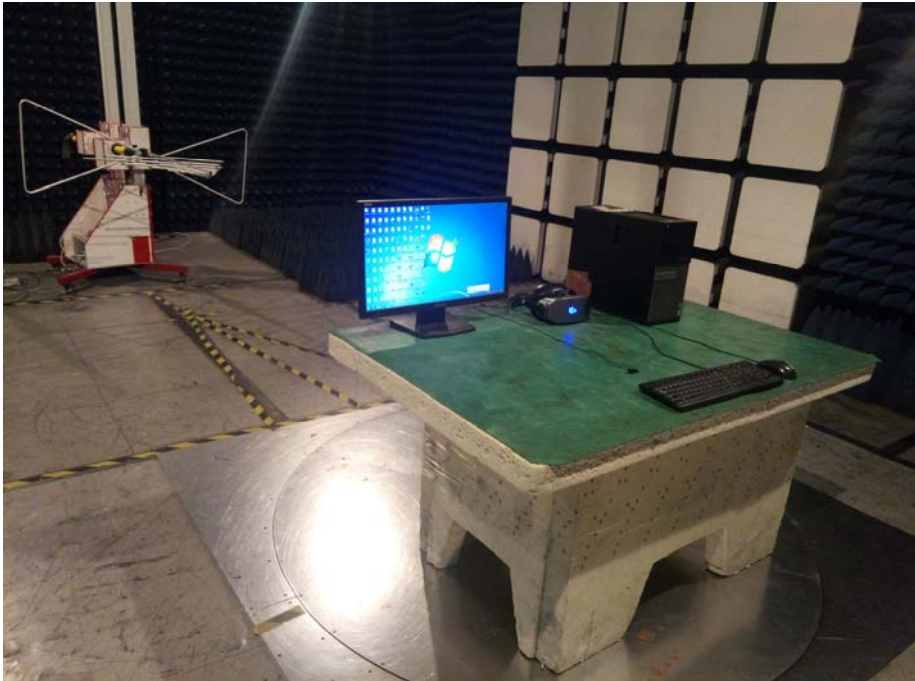

-----The end-----