

IOT3S Wi-Fi Module Specification

V1.0.1

Beijing Winner Microelectronics Co., Ltd. (winner micro)

Address: 18th Floor, Yindu Building, No.67 Fucheng Road, Haidian District, Beijing, China

Tel: +86-10-62161900

Website: www.winnermicro.com/en

Document History

Version	Complete Date	Revision Record	Autor	Auditor
V1.0.0	2018-11-13	Initial Release	Linda	Ray
V1.0.1	2019-02-28	1. Modify power consumption with new version SDK 2. Add IO description	Kevin	Ray

Winner Micro

Content

1	Introduction	1
2	Product Features	1
2.1	Interface.....	1
2.2	Wireless	1
2.3	Others	2
3	Product Specification.....	2
4	Interface.....	3
5	Reference Circuit Design.....	4

Winner Micro

1 Introduction

IOT3S is the Wi-Fi module based on IoT Wi-Fi SoC W600. It integrates stamp hole interface and PCB antenna. This Wi-Fi module can be used for smart appliance, smart home, smart toy and industry field.

2 Product Features

2.1 Interface

- Stamp hole interface with 2.0mm spacing
- 2 x UART ports, band rate range 1200bps~2Mbps
- 1 x High speed SPI with working frequency 0~50MHz
- Integrate PWM controller, max output frequency is 20MHz, max input frequency is 20MHz
- Integrate I²C
- Integrate GPIO
- Integrate I²S

2.2 Wireless

- Support GB15629.11-2006, IEEE802.11 b/g/n standard
- Frequency range: 2.4~2.4835 GHz
- Support Wi-Fi WMM/WMM-PS/WPA/WPA2/WPS
- Support Wi-Fi Direct
- Support EDCA channel access
- Support 20/40M bandwidth
- Support STBC, GreenField, Short-GI and reverse transmission
- Support RIFS interframe space
- Support AMPDU, AMSDU
- Support IEEE802.11n MCS 0~7, MCS32 transmission rate is up to 150Mbps
- Support Short Preamble in 2/5.5/11Mbps
- Support HT-immediate Compressed Block Ack, Normal Ack, No Ack
- Support CTS to self
- Support STA/AP/AP+STA function
- Support up to 32 multicast networks with different encryption methods in BSS
- As AP in BSS, the sum of sites and groups is up to 32 and in IBSS is up to 16

2.3 Others

- Support programmabel GPIO control
- Support AT+command protocol based on ASCII code with UART interface
- Support multiple network protocols: TCP/UDP/ICMP/DHCP/DNS/HTTP
- Support DHCP Server, DNS Server
- Support extensible WEB server
- Support firmware online update

3 Product Specification

Table 3-1 Specification List

	Item	Parameter	Note
Wi-Fi	Wi-Fi Mode	IEEE802.11b/g/n	
	RF Impedance	50 Ω	
	SWR	<-10dB	
	Frequency Range	2.4~2.4835 GHz	
	Reception Sensitivity	20MHz MCS7@-71dBm; 40MHz MCS7@-68dBm; 54Mbps@-73dBm; 11Mbps@-87dBm; 1Mbps@-95dBm;	
	Data Rate in PHY	802.11n MCS 0~7 150Mbps	
	Modulation Mode	DSSS, OFDM, DBPSK, DQPSK, CCK, QAM16/64	
Output Power	IEEE802.11b, DSSS 1Mbps, POUT = +17dBm; IEEE802.11g, OFDM 54Mbps, POUT = +12dBm; IEEE802.11n, OFDM MCS7, POUT = +10dBm;		
Hardware	Interface	UART, SPI, GPIO, PWM, I ² C, I ² S	
	Data Rate	2Mbps@UART (Max) 50Mbps@SPI (Max)	
	Working Voltage	3.0V - 3.6V	
	Working Current	20mA - 110mA	
	Working Humidity	5%~90% (无凝结)	
	Storage Temperature	-40~+125 °C	
	Working Temperature	-40~+85°C	
	Size	16.0mm×24.0mm	

软件部分	Network Type	STA/AP/AP+STA/Wi-Fi Direct	
	Authentication	WEP/WPA-PSK/WPA2-PSK	
	Encryption	WEP64/WEP128/TKIP/CCMP (AES)	
	WPS	WPS	
	Energy Conservation	PS-POLL/Standby	
	Network Protocol	TCP/UDP/ARP/ICMP/DHCP/DNS/HTTP	
	Interface Protocol	AT+Command	

4 Interface

IOT3S module is shown in Figure 4-1:

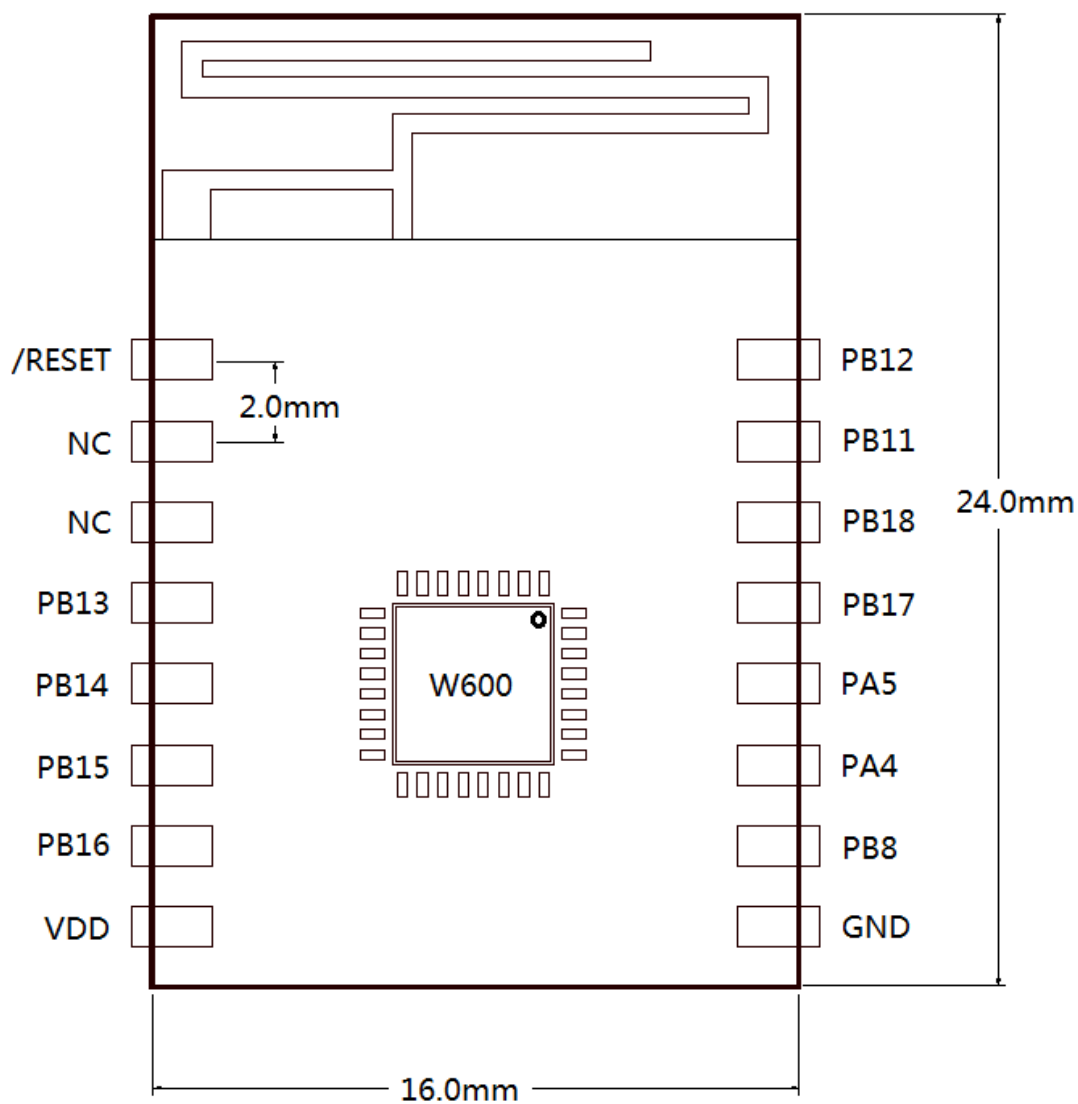

Figure 4-1 IOT3S

Table 4-1 PIN Description

No.	Name	Type	Default Function	Reuse Function
1	RESET	I	RESET with low level	
2	NC			
3	NC			
4	PB_13	I/O	PWM_2	I ² C_SCL, GPIOPB_13
5	PB_14	I/O	H_SPI_INT	I ² C_DAT, GPIOPB_14
6	PB_15	I/O	H_SPI_CS	PWM_4, GPIOPB_15
7	PB_16	I/O	H_SPI_CK	PWM_3, GPIOPB_16
8	VDD	P	Power supply with 3.3V	
9	GND	P	GND	
10	PB_8	I/O	PWM_5	GPIOPB_8
411	PA_4	I/O	UART0_TX	
12	PA_5	I/O	UART0_RX	
13	PB_17	I/O	H_SPI_DI	PWM_2, GPIOPB_17
14	PB_18	I/O	H_SPI_DO	PWM_1, GPIOPB_18
15	PB_11	I/O	UART1_RX	I ² C_SCL, GPIOPB_11
16	PB_12	I/O	UART1_TX	I ² C_DAT, GPIOPB_12

5 Reference Circuit Design

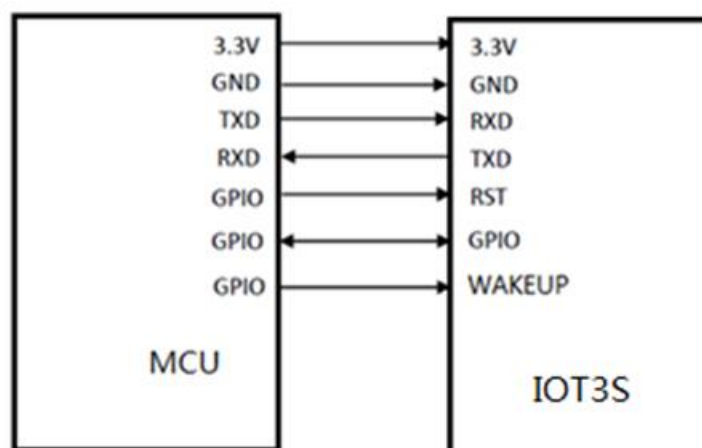

Figure 6-1 IOT3S Reference Design

FCC WARNING

FCC Caution: Any changes or modifications not expressly approved by the party responsible for compliance could void the user's authority to operate this equipment.

This device complies with Part 15 of the FCC Rules.

Operation is subject to the following two conditions: (1) This device may not cause harmful interference, and (2) this device must accept any interference received, including interference that may cause undesired operation.

This device and its antenna(s) must not be co-located or operating in conjunction with any other antenna or transmitter.

15.105 Information to the user.

(b) For a Class B digital device or peripheral, the instructions furnished the user shall include the following or similar statement, placed in a prominent location in the text of the manual:

Note: This equipment has been tested and found to comply with the limits for a Class B digital device, pursuant to part 15 of the FCC Rules.

These limits are designed to provide reasonable protection against harmful interference in a residential installation. This equipment generates, uses and can radiate radio frequency energy and, if not installed and used in accordance with the instructions, may cause harmful interference to radio communications. However, there is no guarantee that interference will not occur in a particular installation. If this equipment does cause harmful interference to radio or television reception, which can be determined by turning the equipment off and on, the user is encouraged to try to correct the interference by one or more of the following measures:

- Reorient or relocate the receiving antenna.
- Increase the separation between the equipment and receiver.
- Connect the equipment into an outlet on a circuit different from that to which the receiver is connected.
- Consult the dealer or an experienced radio/TV technician for help.

This equipment complies with FCC radiation exposure limits set forth for an uncontrolled environment. This equipment should be installed and operated with minimum distance 20 cm between the radiator and your body.

Radiation Exposure Statement:

This equipment complies with FCC radiation exposure limits set forth for an uncontrolled environment.

This transmitter must not be co-located or operating in conjunction with any other antenna or transmitter.

The availability of some specific channels and/or operational frequency bands are country dependent and are firmware programmed at the factory to match the intended destination.

The firmware setting is not accessible by the end user.

The final end product must be labelled in a visible area with the following:

“Contains Transmitter Module 2AGQ7-IOT3S”