



## 6.8 CONDUCTED UNDESIRABLE EMISSION

### 6.8.1 LIMIT

According to 15.407(b) ,

- (1) For transmitters operating in the 5.15-5.25 GHz band: all emissions outside of the 5.15-5.35 GHz band shall not exceed an EIRP of -27 dBm/MHz.
- (2) For transmitters operating in the 5.725–5.850 GHz band: all emissions within the frequency range from the band edge to 10 MHz above or below the band edge shall not exceed an EIRP of –17 dBm/MHz; for frequencies 10 MHz or greater above or below the band edge, emissions shall not exceed an EIRP of –27 dBm/MHz.
- (3) The provisions of §15.205 apply to intentional radiators operating under this section.

### 6.8.2 MEASUREMENT EQUIPMENT USED

Name of Equipment	Manufacturer	Model	Serial Number	Last Calibration	Due Calibration
Spectrum Analyzer	Agilent	N9010A	MY52221469	02/21/2016	02/20/2017

*Remark: Each piece of equipment is scheduled for calibration once a year.*

### 6.8.3 TEST CONFIGURATION

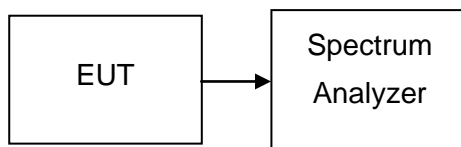

### 6.8.4 TEST PROCEDURE

Conducted RF measurements of the transmitter output were made to confirm that the EUT antenna port conducted emissions meet the specified limit and to identify any spurious signals that require further investigation or measurements on the radiated emissions site.

The transmitter output is connected to the spectrum analyzer. The resolution bandwidth is set to 1 MHz. The video bandwidth is set to 1 MHz. Peak detection measurements are compared to the average EIRP limit, adjusted for the maximum antenna gain. If necessary, additional average detection measurements are made.

Measurements are made over the 30 MHz to 40 GHz range with the transmitter set to the lowest, middle, and highest channels.



### 6.8.5 TEST RESULTS

No non-compliance noted

#### Test Plot

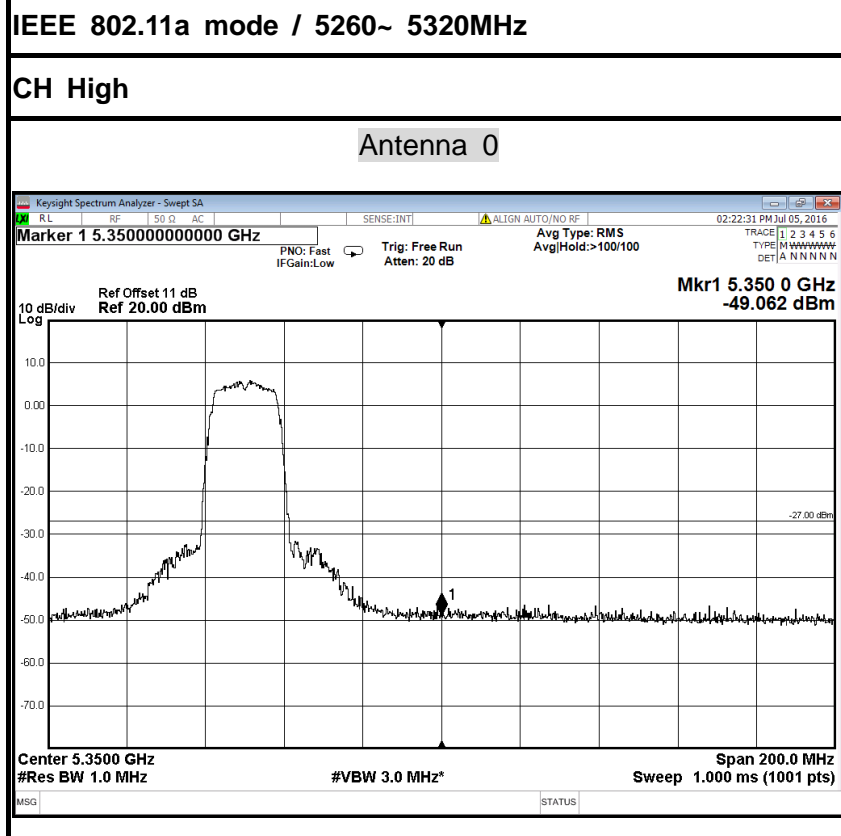
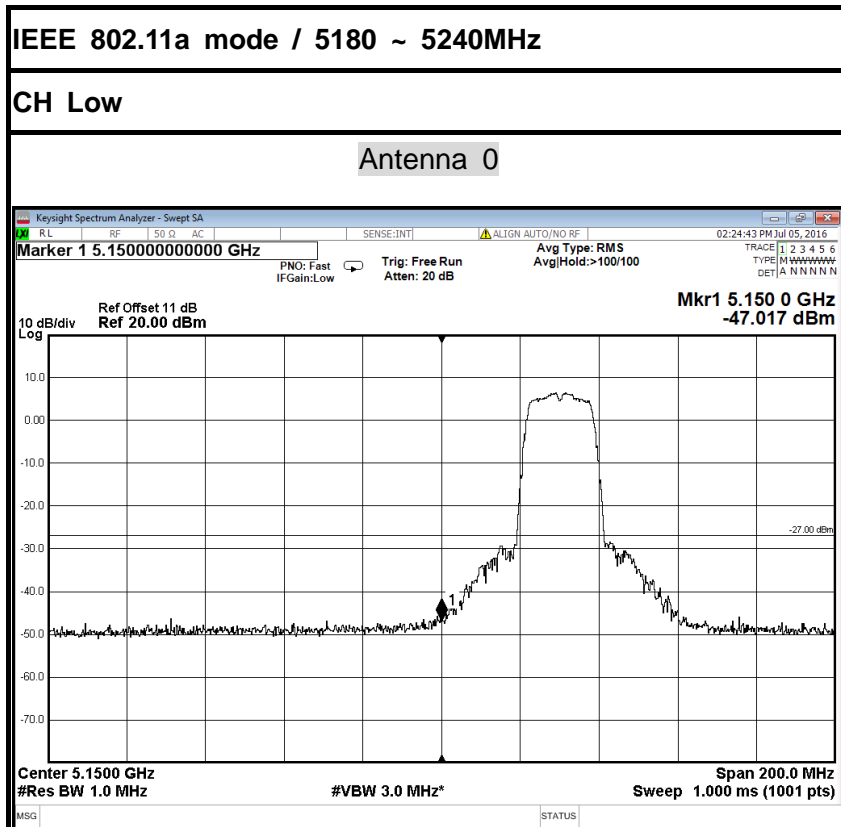



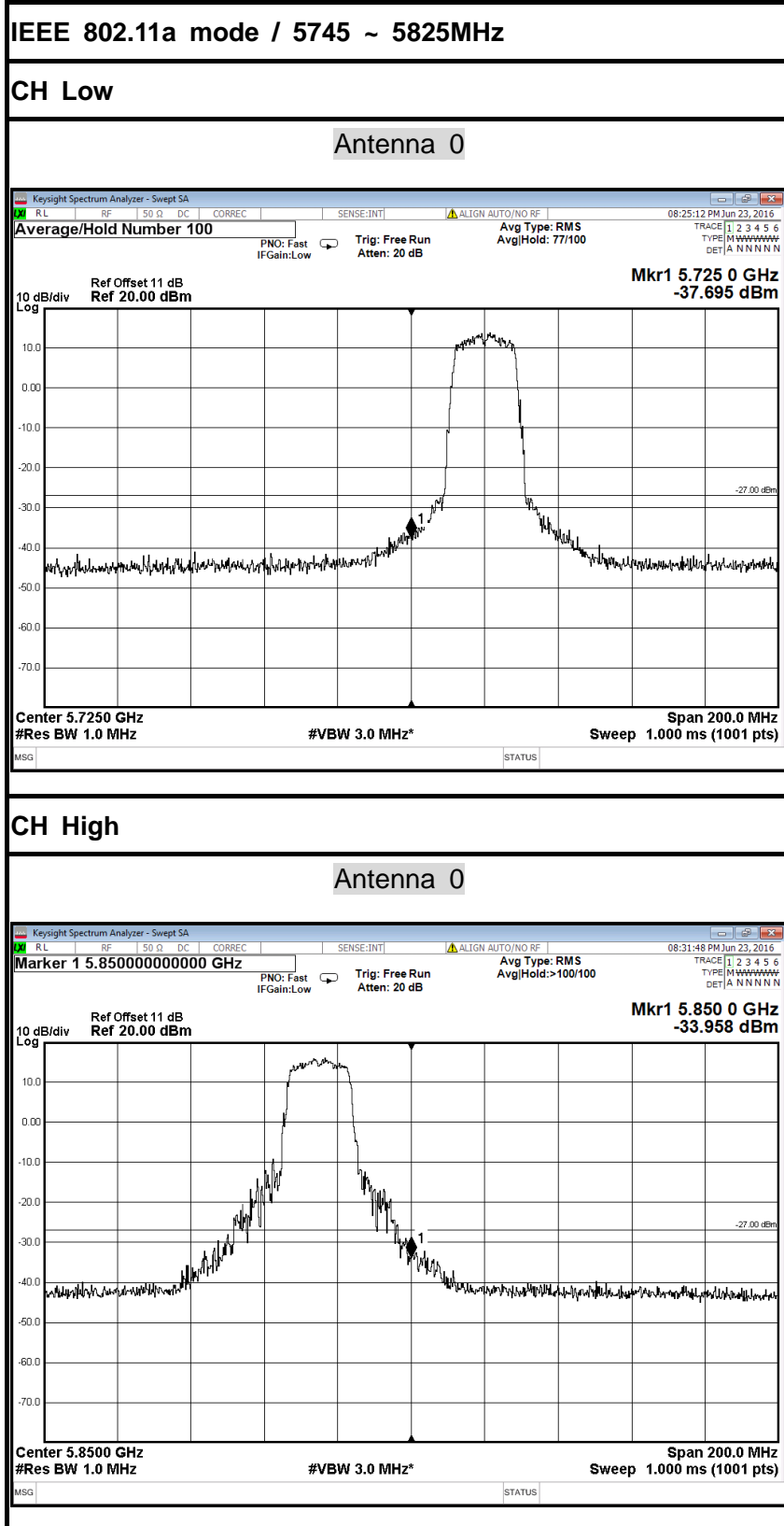

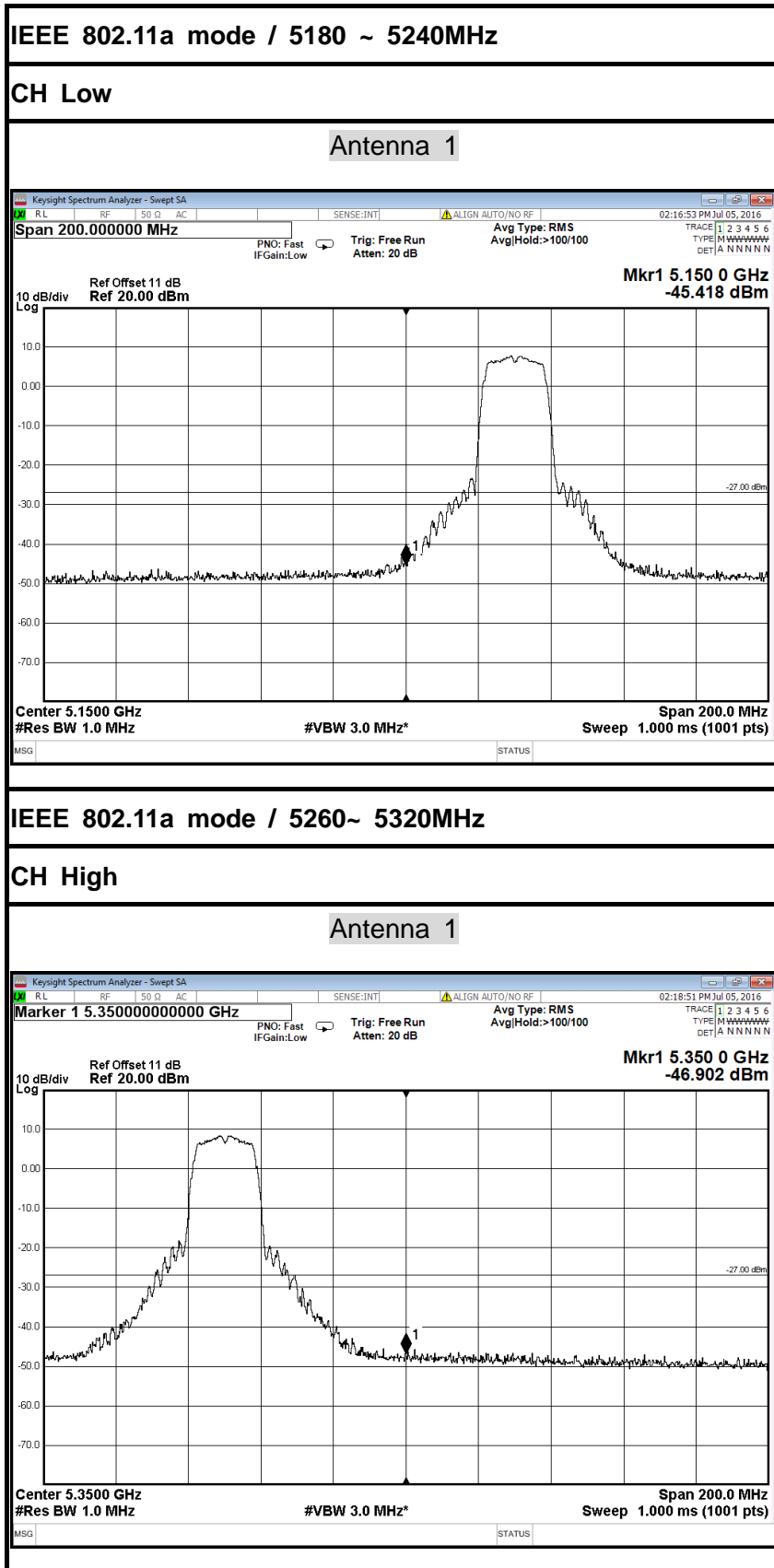

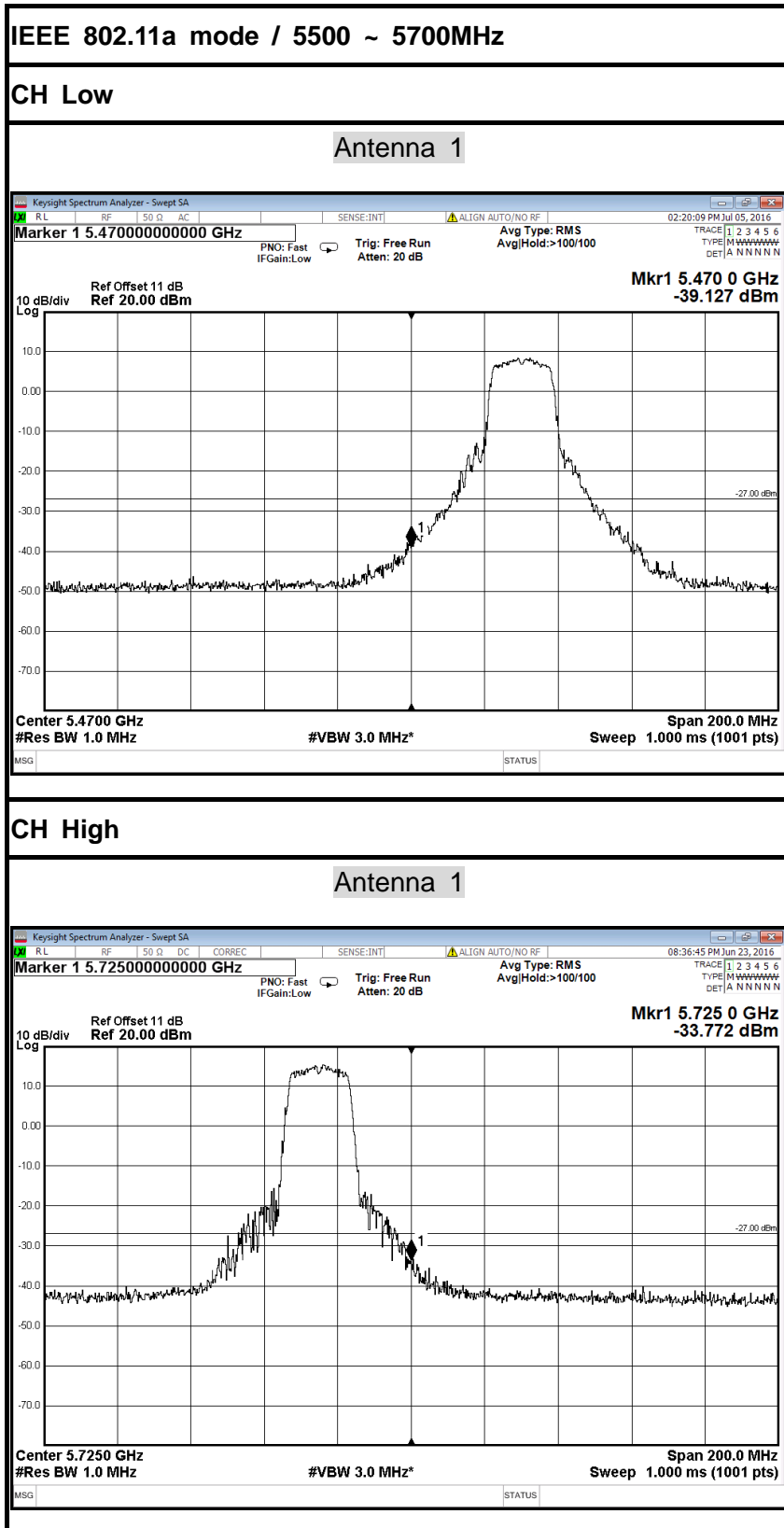

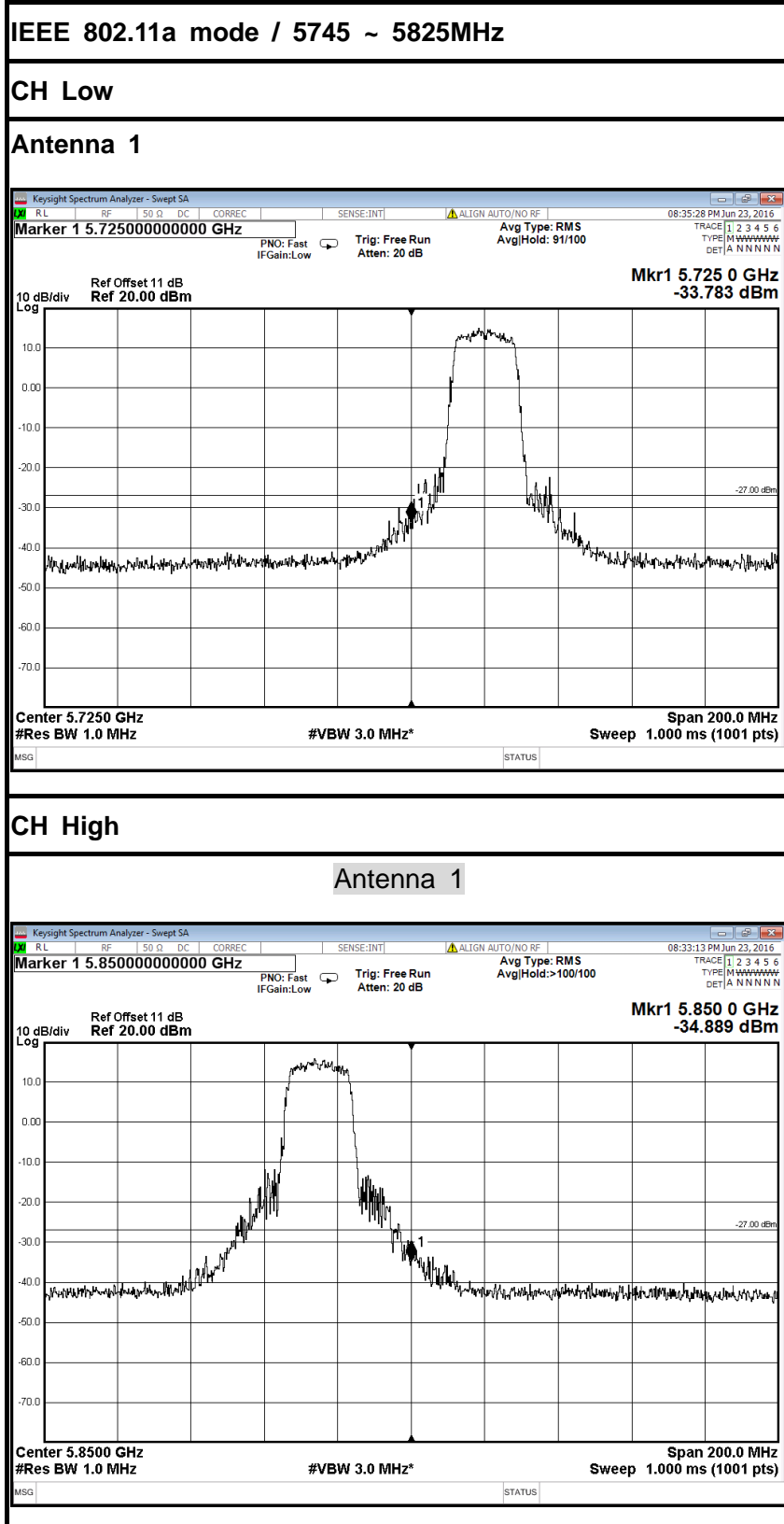

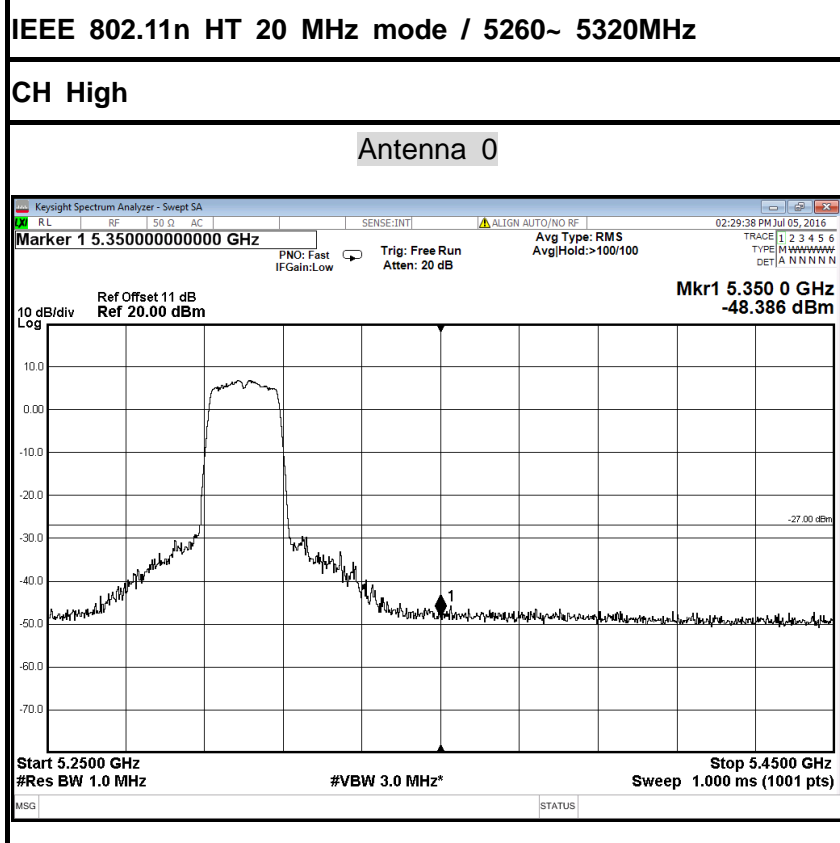
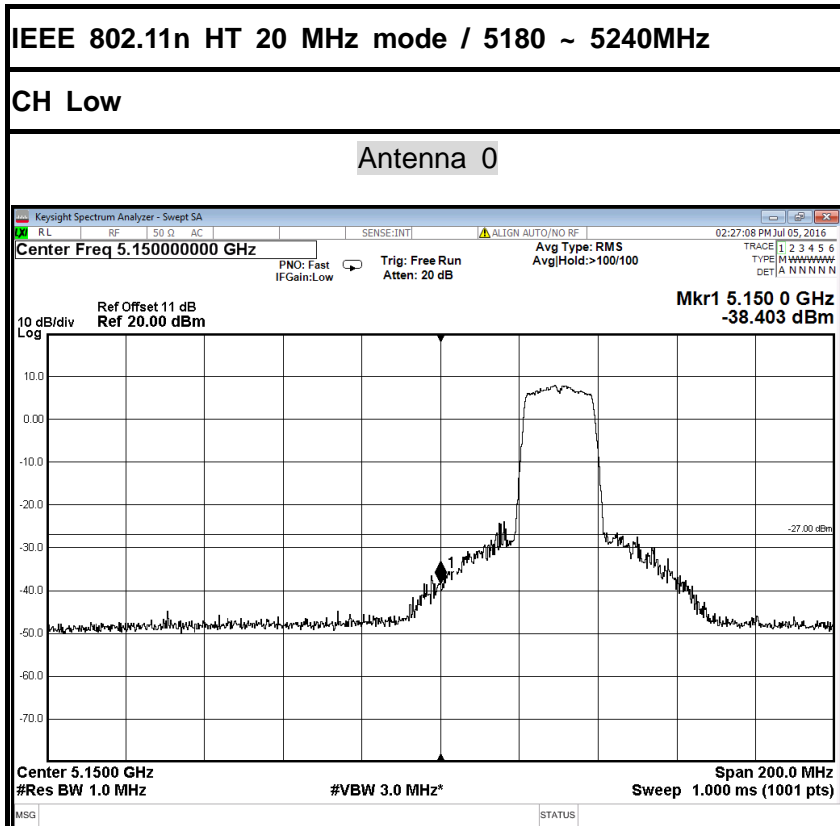



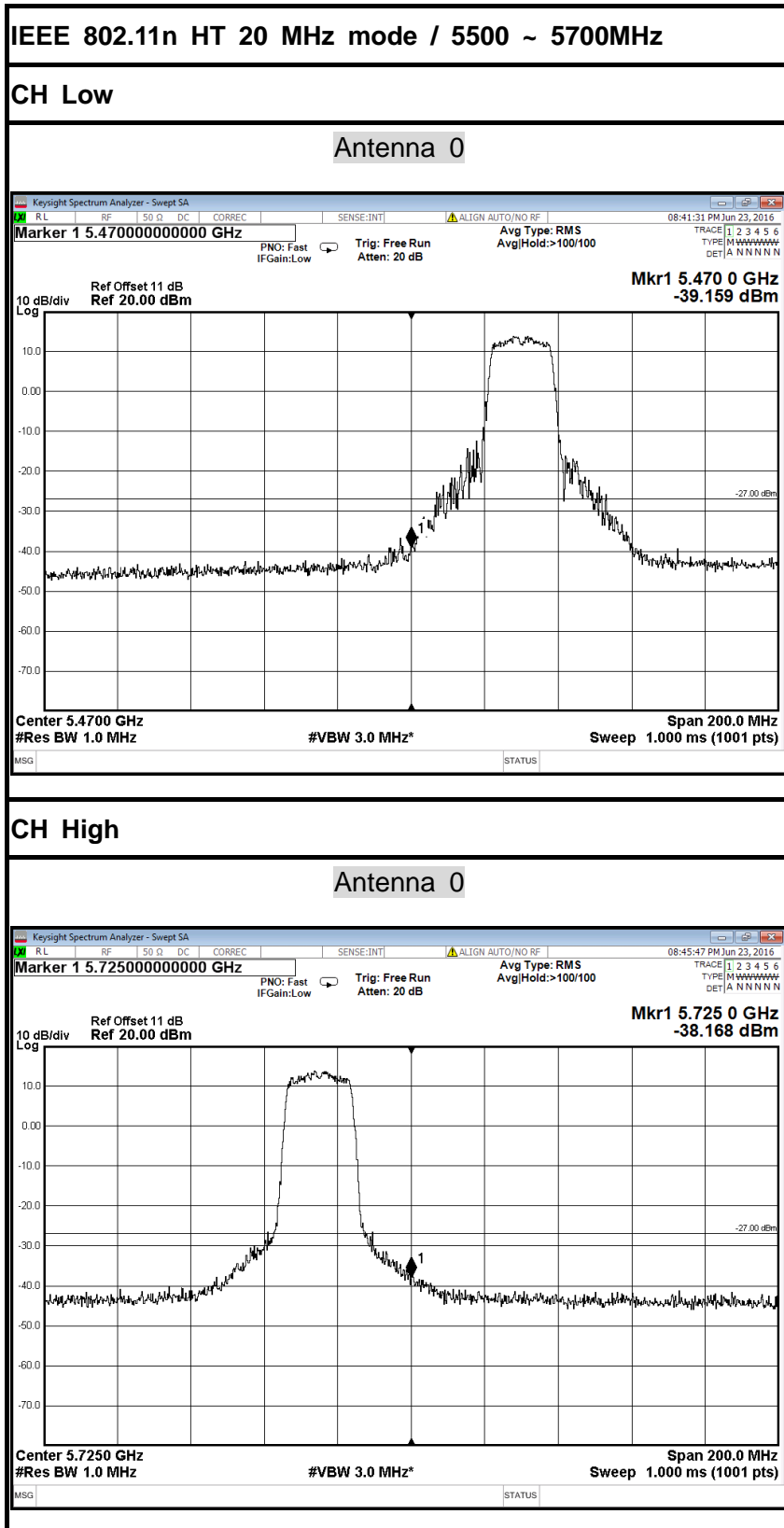

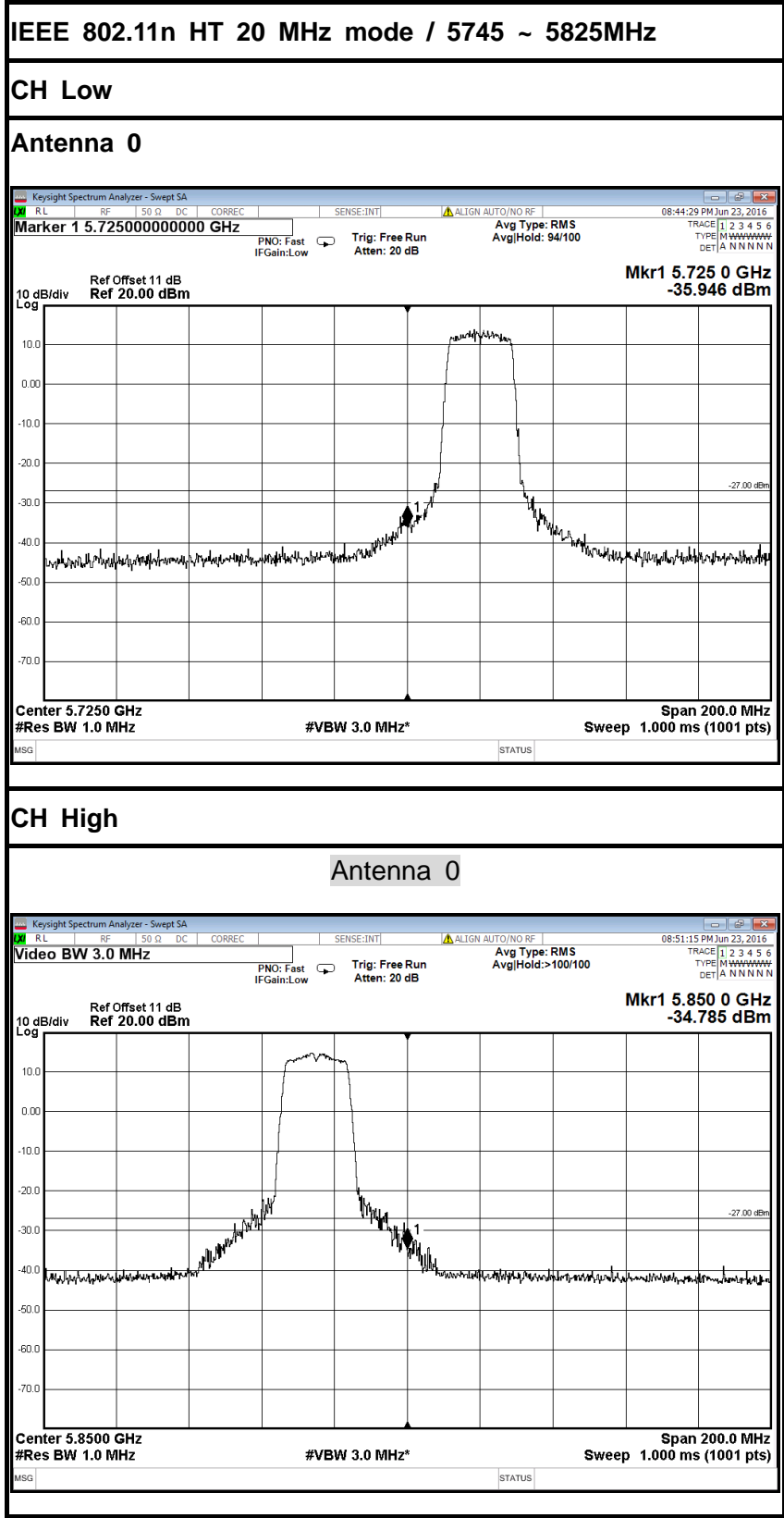



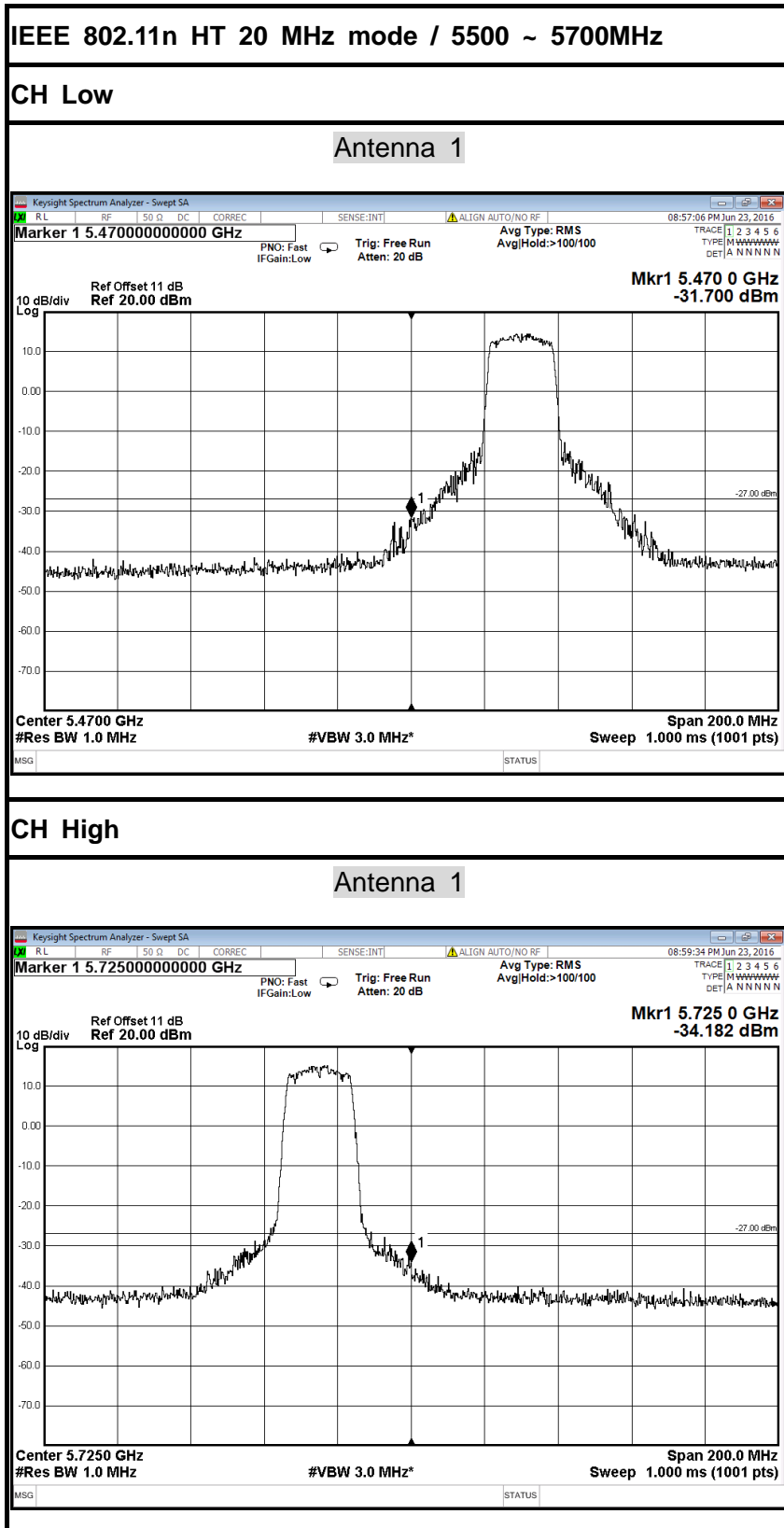

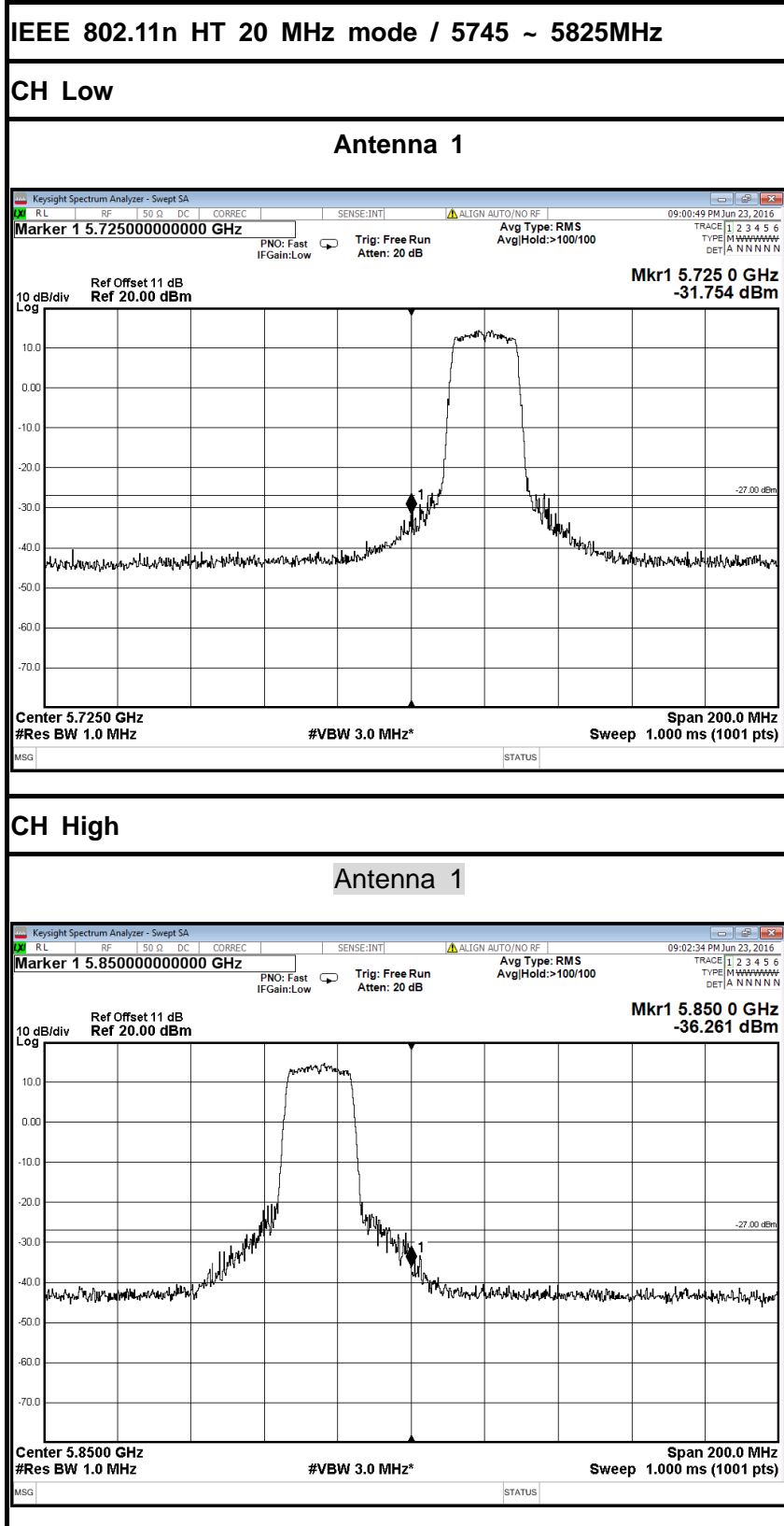

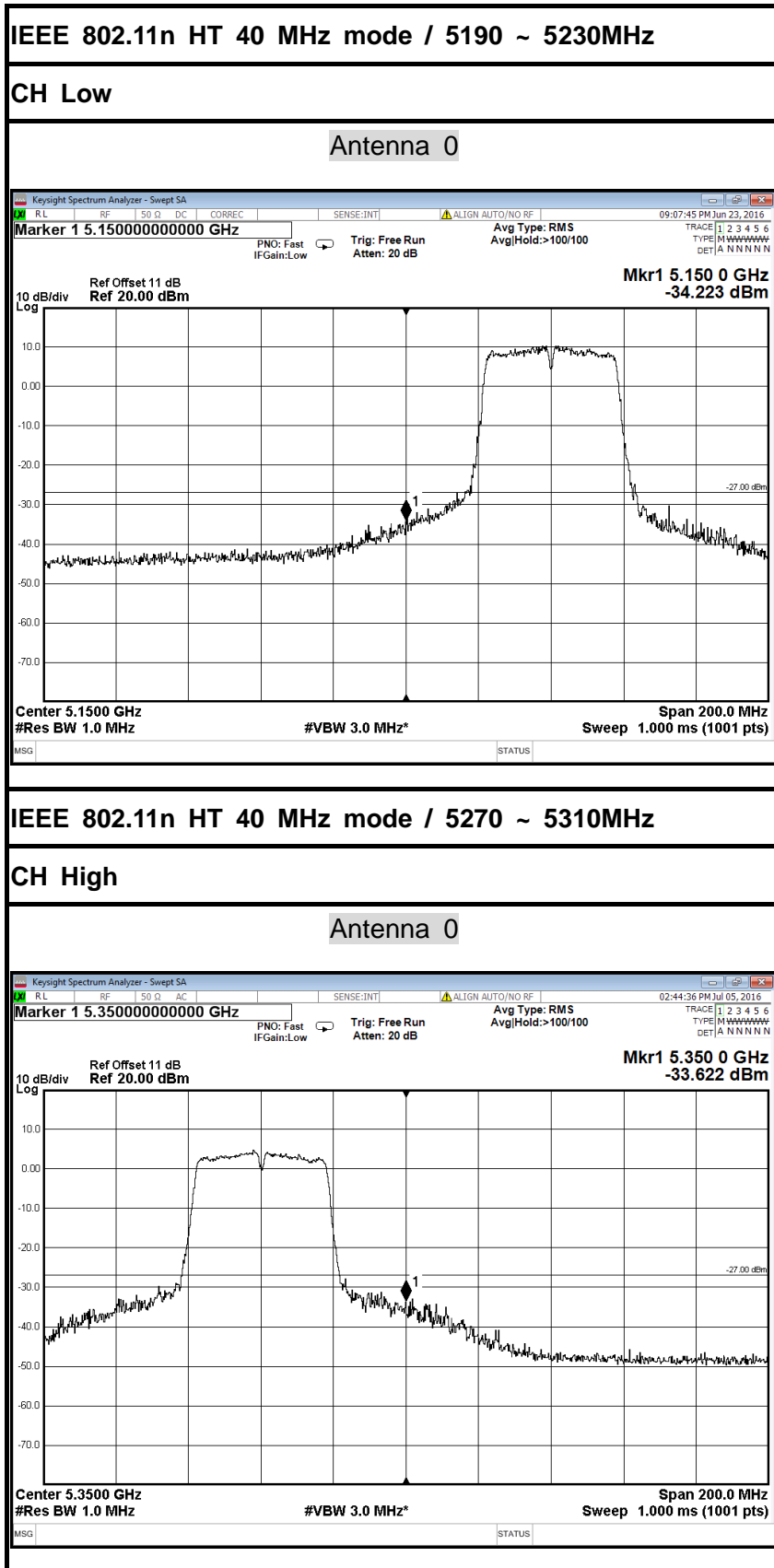

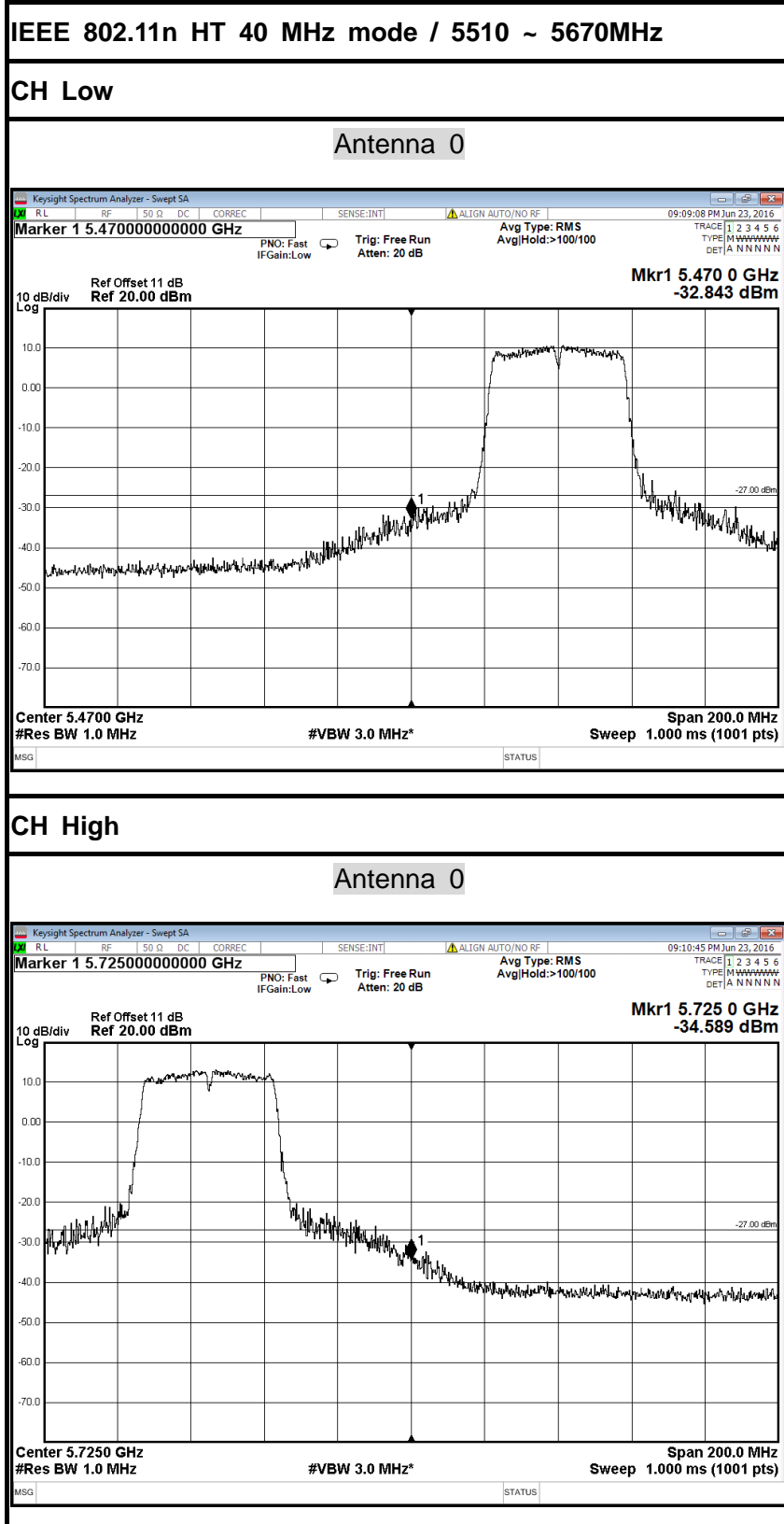





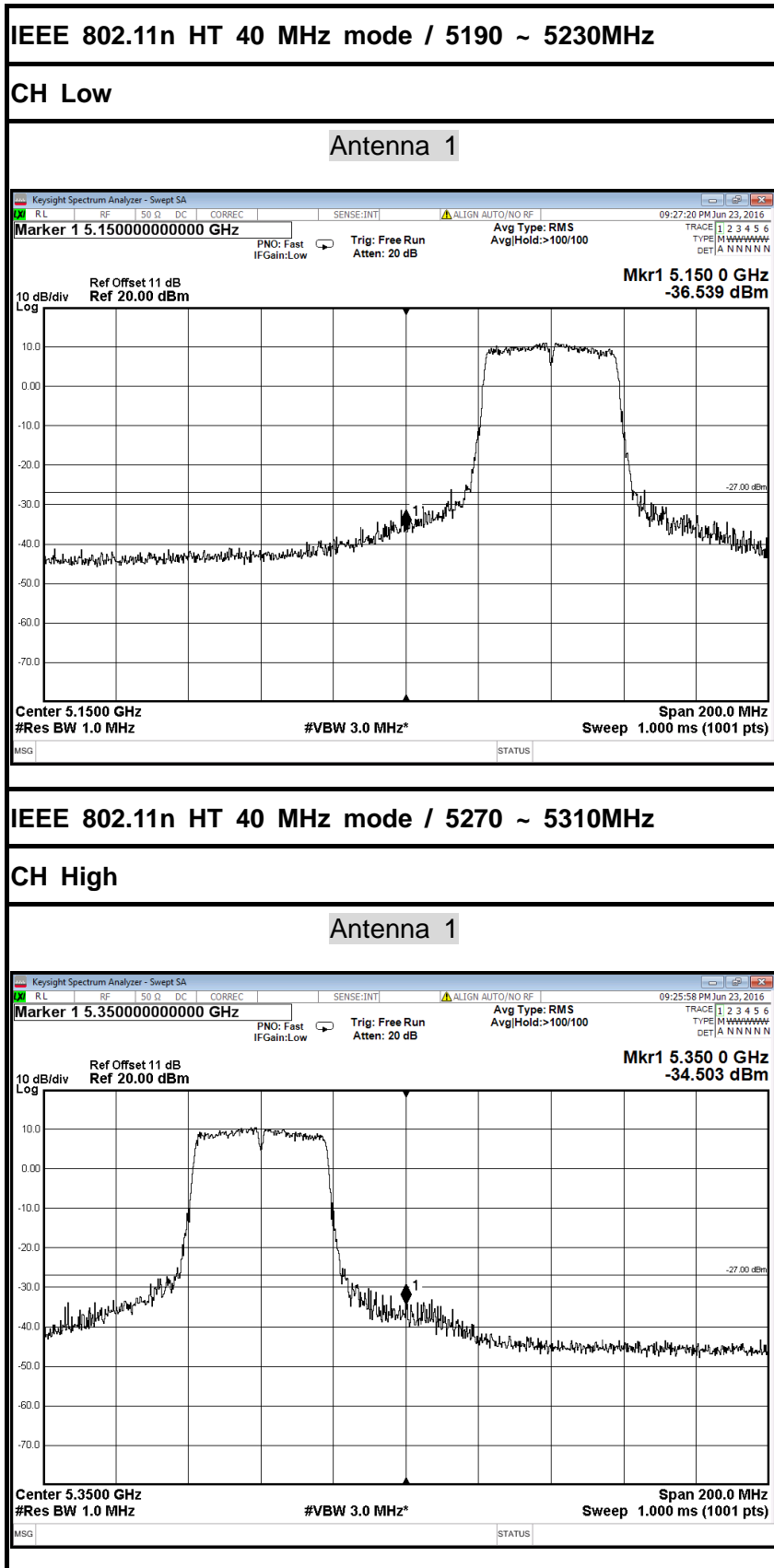

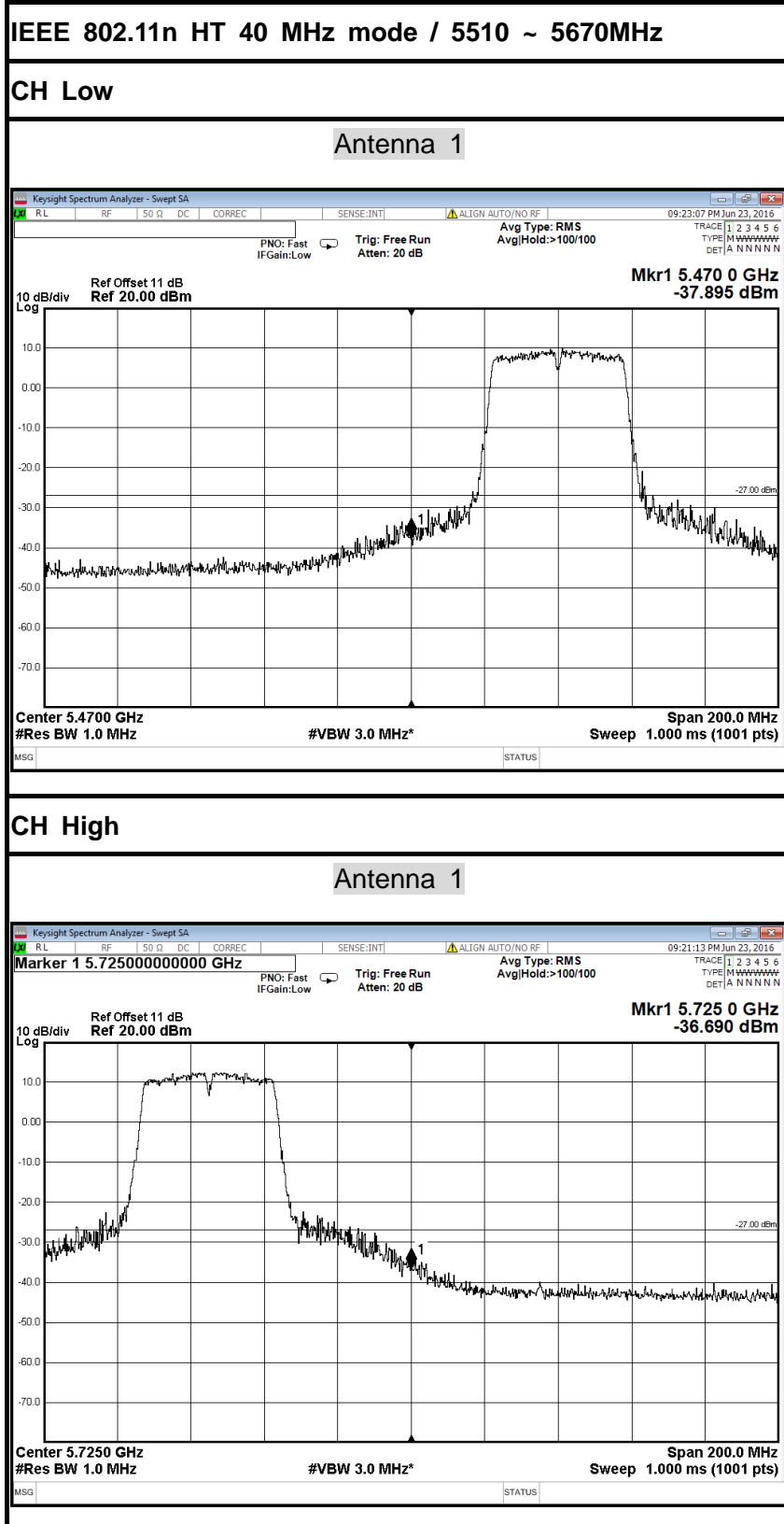

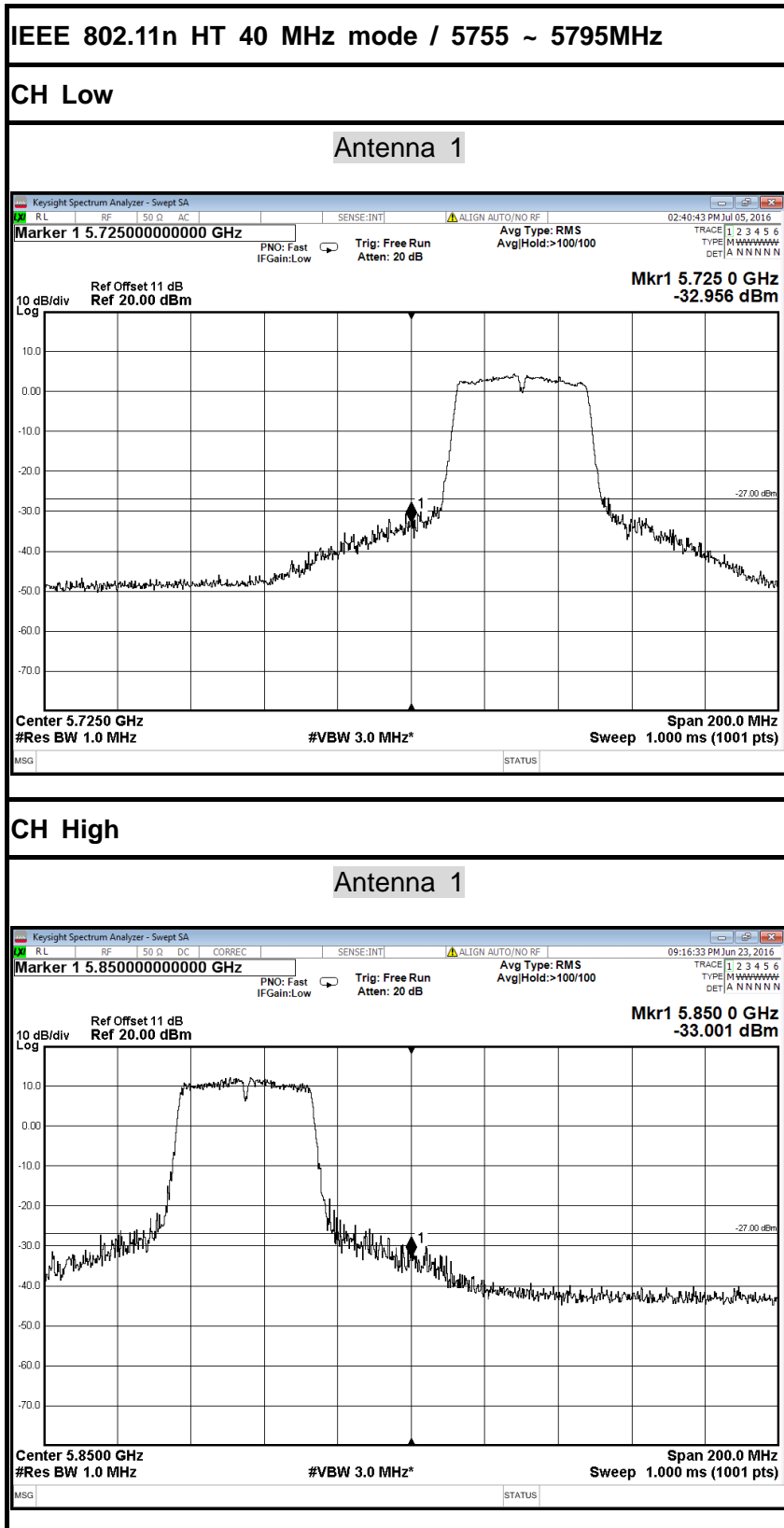

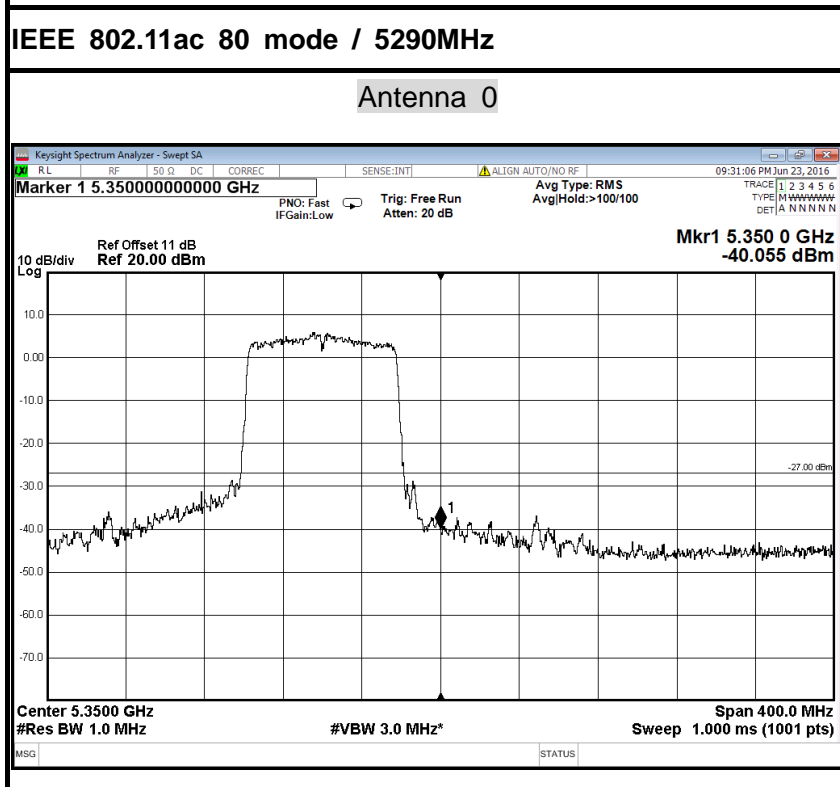
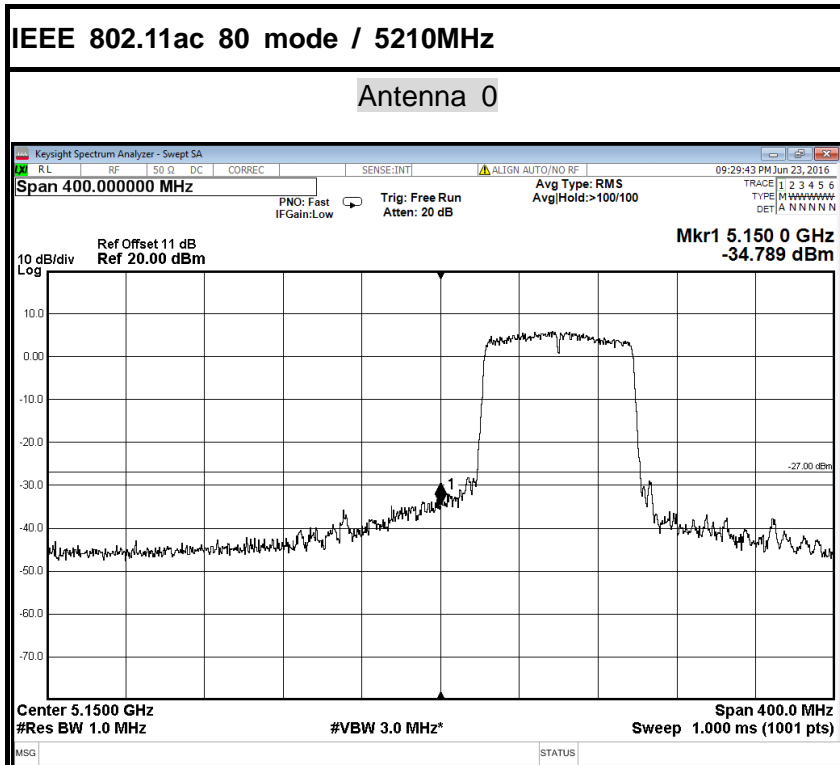



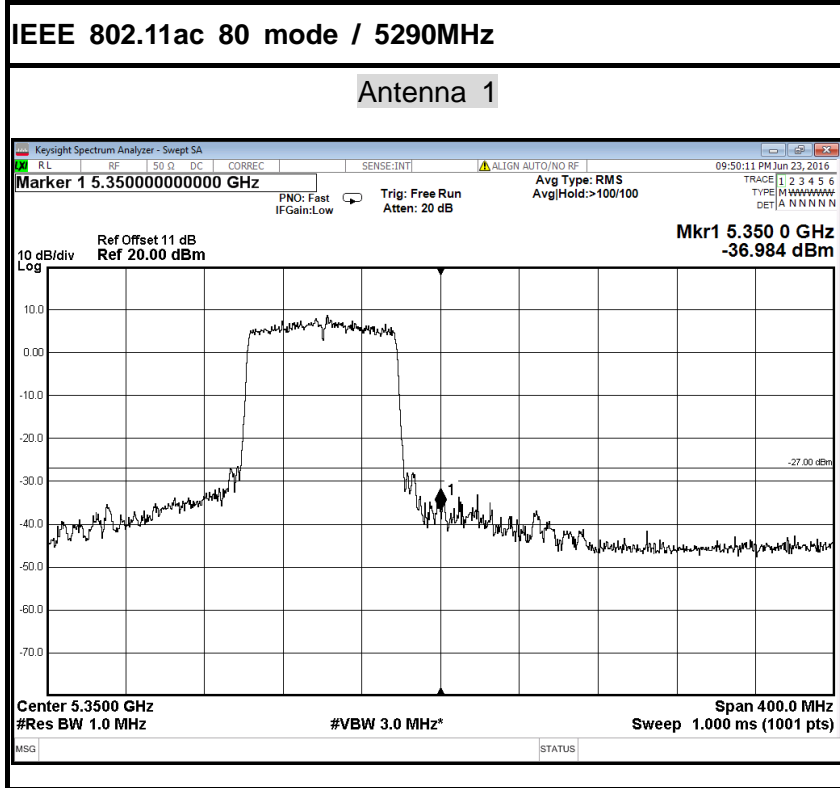
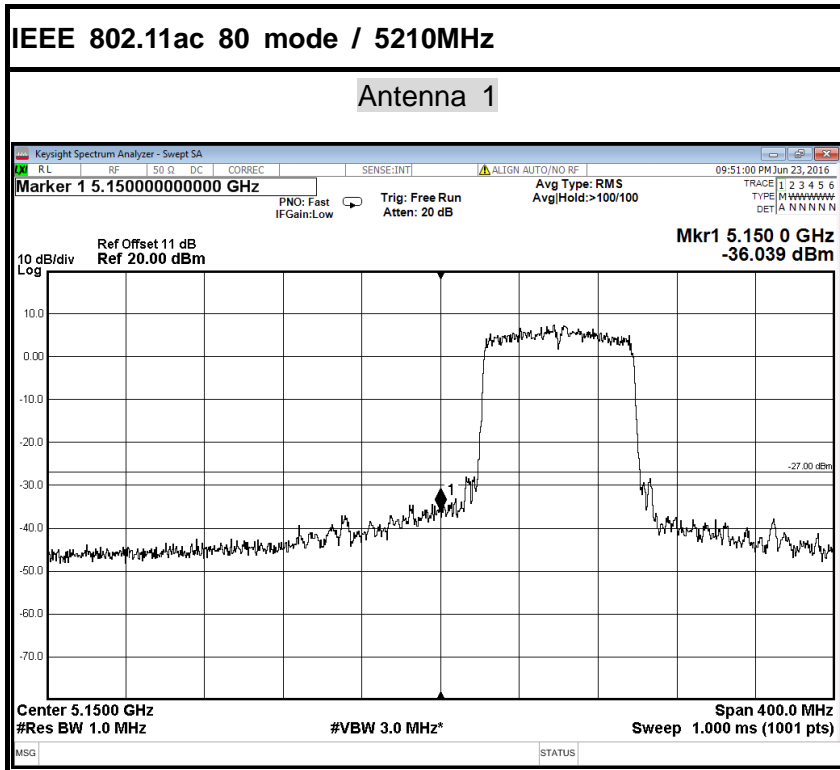

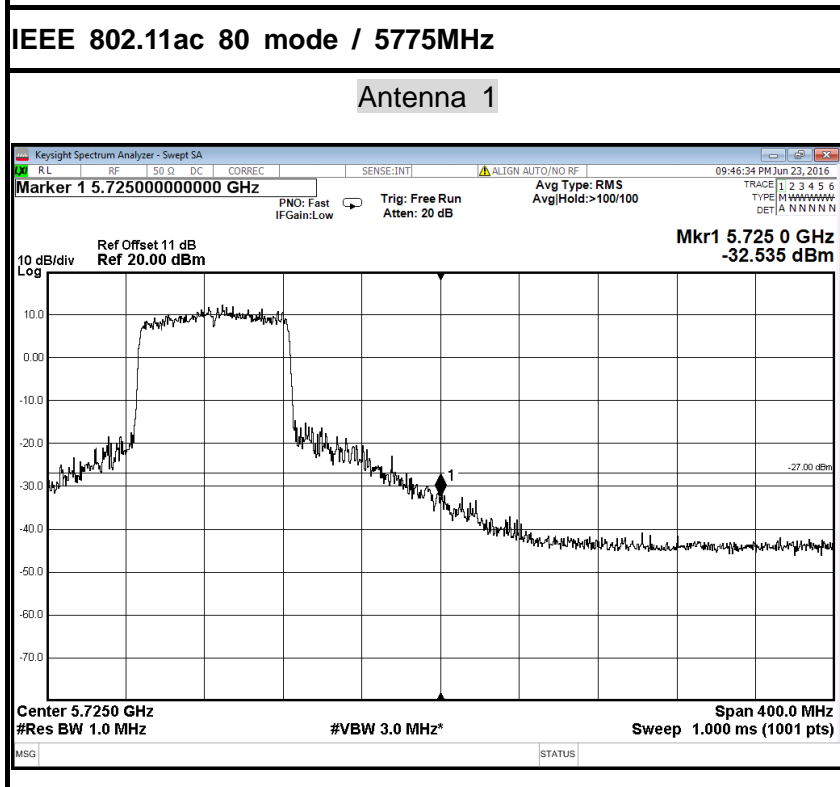
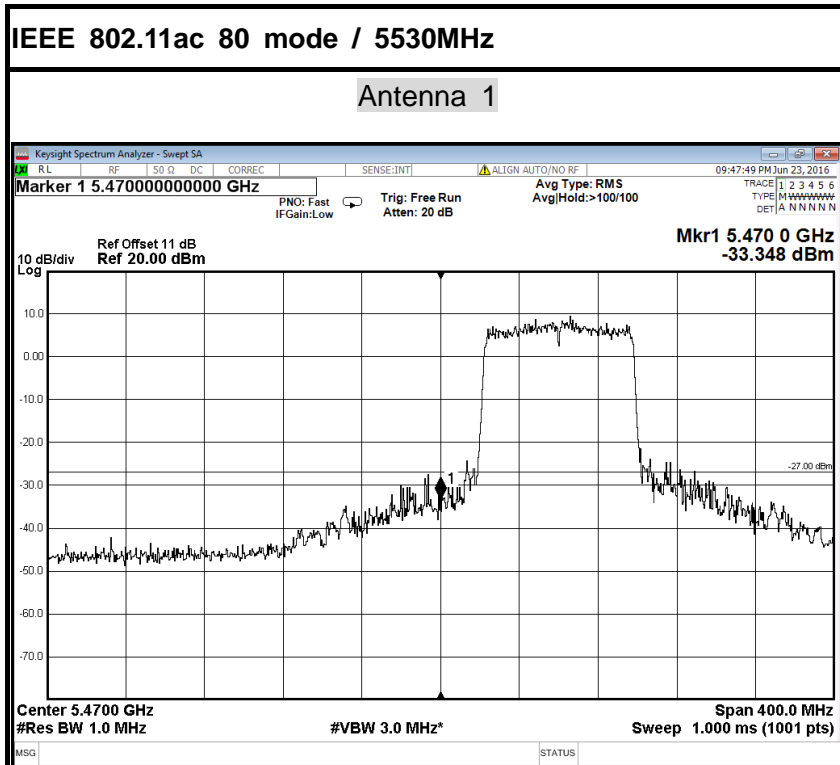



## 6.9 POWERLINE CONDUCTED EMISSIONS

### 6.9.1 LIMIT

According to §15.207(a), except as shown in paragraphs (b) and (c) of this section, for an intentional radiator that is designed to be connected to the public utility (AC) power line, the radio frequency voltage that is conducted back onto the AC power line on any frequency or frequencies within the band 150 kHz to 30 MHz shall not exceed the limits in the following table, as measured using a 50  $\mu$ H/50 ohms line impedance stabilization network (LISN). Compliance with the provisions of this paragraph shall be based on the measurement of the radio frequency voltage between each power line and ground at the power terminal. The lower limit applies at the boundary between the frequency ranges.

Frequency Range (MHz)	Limits (dB $\mu$ V)	
	Quasi-peak	Average
0.15 to 0.50	66 to 56*	56 to 46*
0.50 to 5	56	46
5 to 30	60	50

\* Decreases with the logarithm of the frequency.

### 6.9.2 TEST INSTRUMENTS

Conducted Emission Test Site					
Name of Equipment	Manufacturer	Model Number	Serial Number	Last Calibration	Due Calibration
EMI TEST RECEIVER	ROHDE&SCHWARZ	ESCI	100783	02/21/2016	02/20/2017
LISN(EUT)	ROHDE&SCHWARZ	ENV216	101543-WX	02/21/2016	02/20/2017
LISN	EMCO	3825/2	8901-1459	02/21/2016	02/20/2017
Temp. / Humidity Meter	VICTOR	HTC-1	N/A	02/21/2016	02/20/2017
Test S/W	FARAD	EZ-EMC/ CCS-3A1-CE			

- NOTE:** 1. The calibration interval of the above test instruments is 12 months and the calibrations are traceable to NML/ROC and NIST/USA.  
2. N.C.R = No Calibration Request.





### 6.9.3 TEST CONFIGURATION

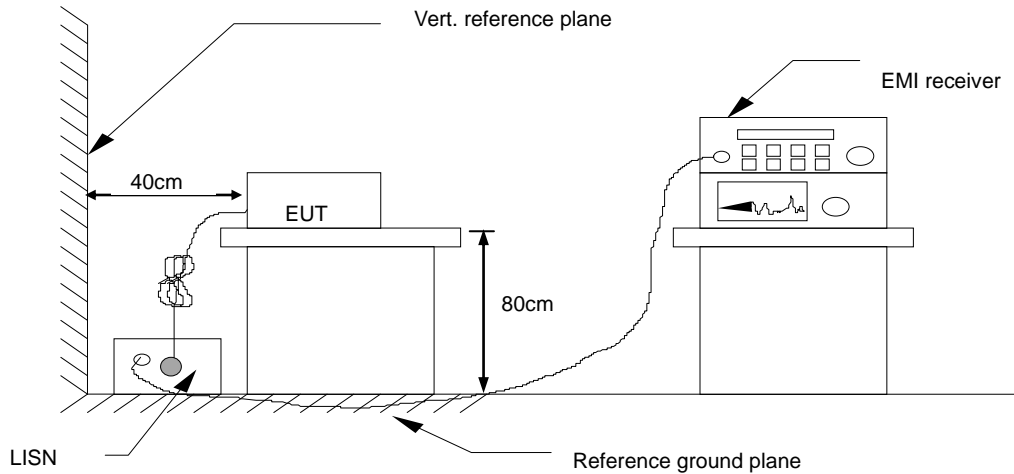

### 6.9.4 TEST PROCEDURE

1. The EUT was placed on a table, which is 0.8m above ground plane.
2. Maximum procedure was performed on the six highest emissions to ensure EUT compliance.
3. Repeat above procedures until all frequency measured were complete.

### 6.9.5 DATA SAMPLE

Frequency (MHz)	QuasiPeak Reading (dBuV)	Average Reading (dBuV)	Correction Factor (dB)	QuasiPeak Result (dBuV)	Average Result (dBuV)	QuasiPeak Limit (dBuV)	Average Limit (dBuV)	QuasiPeak Margin (dB)	Average Margin (dB)	Remark (Pass/Fail)
X.XXXX	32.69	25.65	11.52	44.21	37.17	65.78	55.79	-21.57	-18.62	Pass

Factor = Insertion loss of LISN + Cable Loss  
Result = Quasi-peak Reading/ Average Reading + Factor  
Limit = Limit stated in standard  
Margin = Result (dBuV) – Limit (dBuV)



6.9.6 TEST RESULTS

<b>Model No.</b>	SK-WB8	<b>RBW,VBW</b>	9 kHz
<b>Environmental Conditions</b>	22°C, 45% RH	<b>Test Mode</b>	Mode 3
<b>Tested by</b>	Darry Wu	<b>Line</b>	L1
<b>Test Date</b>	2016/04/27		

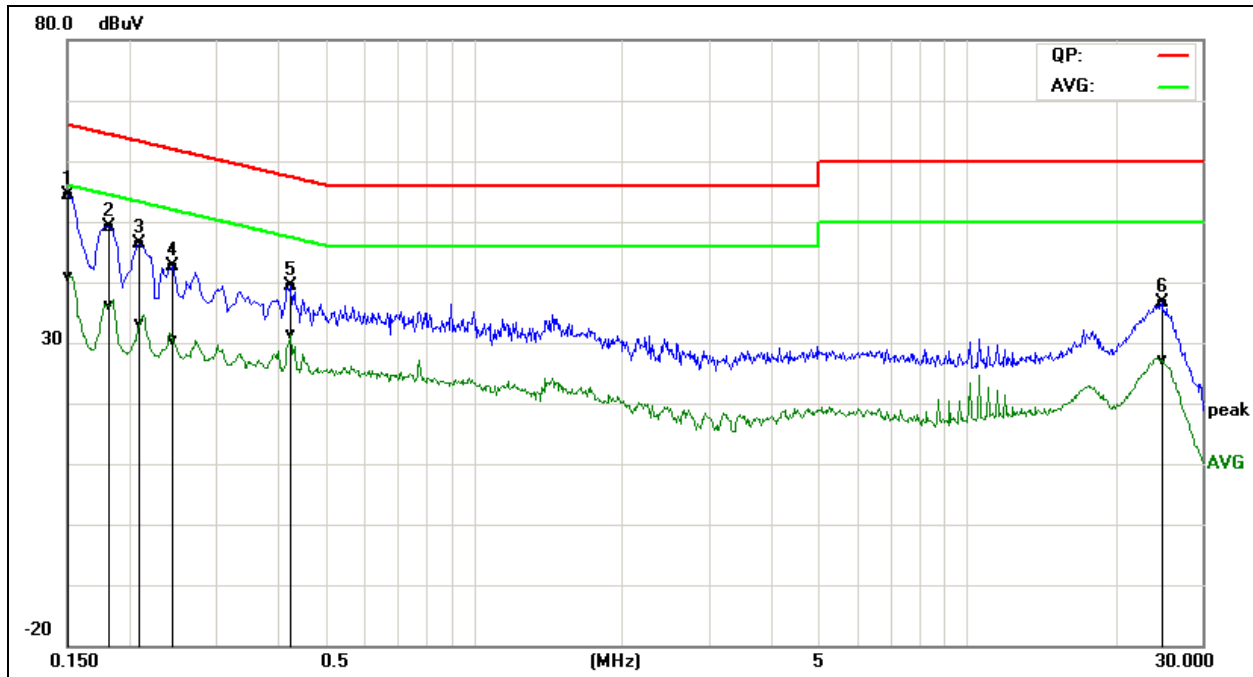

Frequency (MHz)	QuasiPeak Reading (dBuV)	Average Reading (dBuV)	Correction Factor (dB)	QuasiPeak Result (dBuV)	Average Result (dBuV)	QuasiPeak Limit (dBuV)	Average Limit (dBuV)	QuasiPeak Margin (dB)	Average Margin (dB)	Remark (Pass/Fail)
0.1500	44.83	31.25	9.58	54.41	40.83	65.99	56.00	-11.58	-15.17	Pass
0.1819	39.51	26.41	9.65	49.16	36.06	64.39	54.40	-15.23	-18.34	Pass
0.2100	36.77	23.52	9.69	46.46	33.21	63.20	53.21	-16.74	-20.00	Pass
0.2460	33.01	20.82	9.67	42.68	30.49	61.89	51.89	-19.21	-21.40	Pass
0.4260	29.88	21.80	9.60	39.48	31.40	57.33	47.33	-17.85	-15.93	Pass
24.8460	26.66	16.98	10.08	36.74	27.06	60.00	50.00	-23.26	-22.94	Pass

Remark: L1 = Line One (Live Line)



<b>Model No.</b>	SK-WB8	<b>RBW,VBW</b>	9 kHz
<b>Environmental Conditions</b>	22°C, 45% RH	<b>Test Mode</b>	Mode 3
<b>Tested by</b>	Darry Wu	<b>Line</b>	L1
<b>Test Date</b>	2016/04/27		

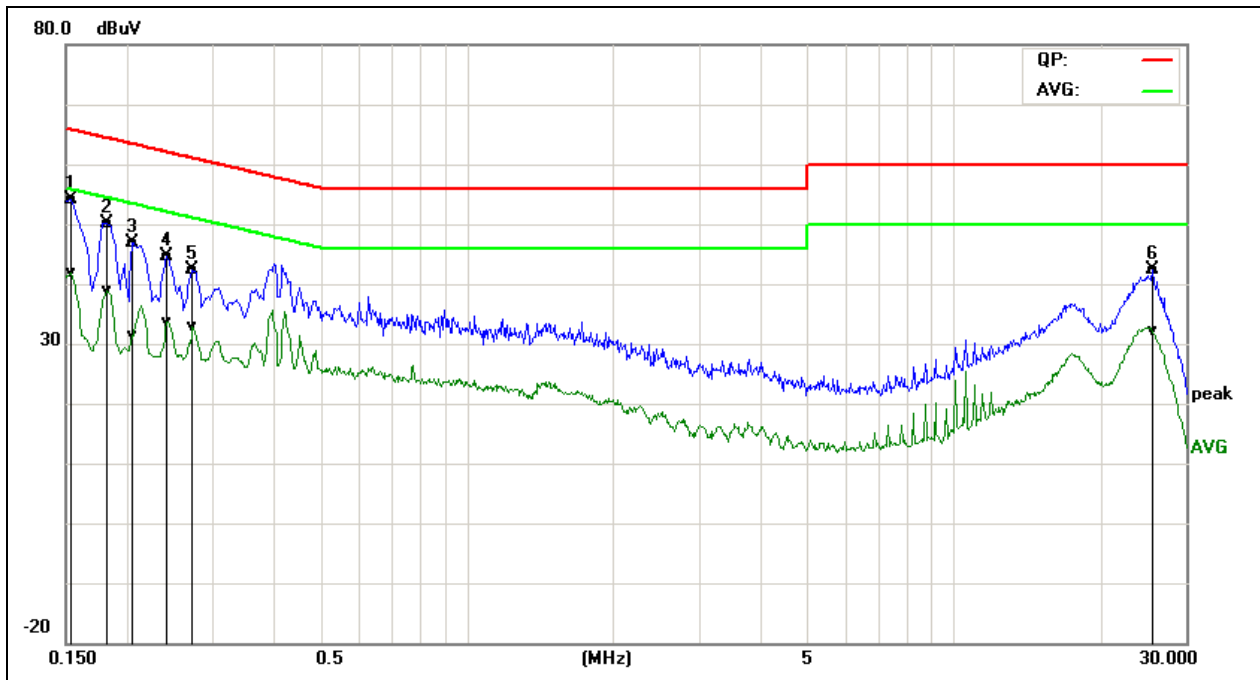

Frequency (MHz)	QuasiPeak Reading (dBuV)	Average Reading (dBuV)	Correction Factor (dB)	QuasiPeak Result (dBuV)	Average Result (dBuV)	QuasiPeak Limit (dBuV)	Average Limit (dBuV)	QuasiPeak Margin (dB)	Average Margin (dB)	Remark (Pass/Fail)
0.1539	44.30	31.96	9.88	54.18	41.84	65.78	55.79	-11.60	-13.95	Pass
0.1819	40.23	28.87	9.89	50.12	38.76	64.39	54.40	-14.27	-15.64	Pass
0.2060	37.11	21.39	9.89	47.00	31.28	63.36	53.37	-16.36	-22.09	Pass
0.2420	34.67	23.85	9.86	44.53	33.71	62.02	52.03	-17.49	-18.32	Pass
0.2740	32.62	23.05	9.84	42.46	32.89	60.99	51.00	-18.53	-18.11	Pass
25.6340	32.52	22.31	9.79	42.31	32.10	60.00	50.00	-17.69	-17.90	Pass

**Remark:** L2 = Line Two (Neutral Line)



## 6.10 FREQUENCY STABILITY

### 6.10.1 LIMIT

According to §15.407(g), manufacturers of U-NII devices are responsible for ensuring frequency stability such that an emission is maintained within the band of operation under all conditions of normal operation as specified in the operational description.

### 6.10.2 TEST INSTRUMENTS

Name of Equipment	Manufacturer	Model Number	Serial Number	Last Calibration	Due Calibration
Spectrum Analyzer	Agilent	E4446A	US44300399	02/21/2016	02/20/2017
DC Power Supply	DAZHENG	PS-605D	20018978	N.C.R	N.C.R
AC POWER SOUCE	UMART	HPA1010	N/A	N.C.R	N.C.R
Power Meter	Anritsu	ML2495A	1204003	02/21/2016	02/20/2017
Power Sensor	Anritsu	MA2411B	1126150	02/21/2016	02/20/2017
Temperature Chamber	TERCHY	MHG-800N	E21104	11/18/2015	11/17/2016
Temp. / Humidity Meter	Anymetre	JR913	N/A	02/21/2016	02/20/2017

### 6.10.3 TEST CONFIGURATION

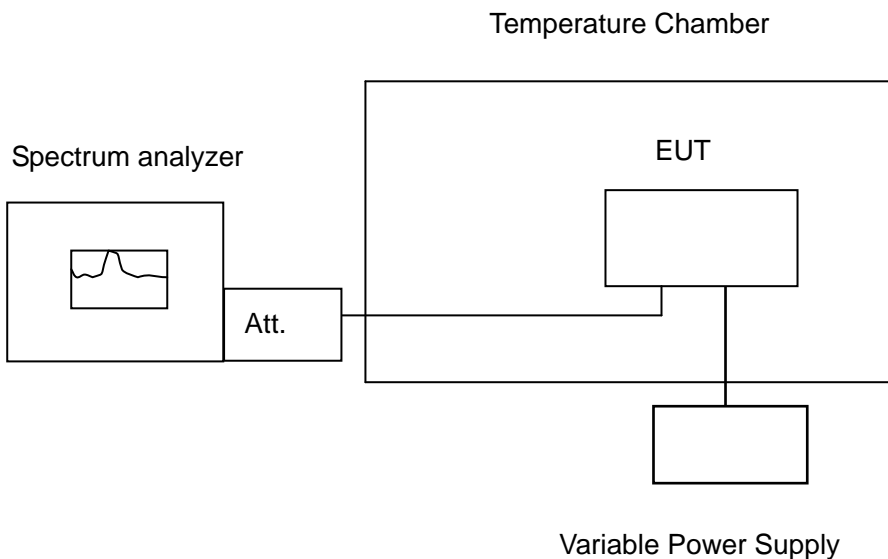

**Remark:** Measurement setup for testing on Antenna connector



#### 6.10.4 TEST PROCEDURE

The equipment under test was connected to an external AC or DC power supply and input rated voltage. RF output was connected to a frequency counter or spectrum analyzer via feed through attenuators. The EUT was placed inside the temperature chamber. Set the spectrum analyzer RBW low enough to obtain the desired frequency resolution and measure EUT 20°C operating frequency as reference frequency. Turn EUT off and set the chamber temperature to -20°C. After the temperature stabilized for approximately 30 minutes recorded the frequency. Repeat step measure with 10°C increased per stage until the highest temperature of +50°C reached.

#### 6.10.5 TEST RESULTS

*No non-compliance noted.*



Test Data  
Antenna 0

IEEE 802.11a MHz mode / 5180 ~ 5240MHz (Low)

Environment Temperature (°C)	Volage (V)	Measured Frequency (MHz)	limit Range	Test Result
50	120	5179.952419	5150-5250	PASS
40	120	5179.976298	5150-5250	PASS
30	120	5179.987338	5150-5250	PASS
20	120	5179.998200	5150-5250	PASS
10	120	5179.981024	5150-5250	PASS
0	120	5179.991367	5150-5250	PASS
-10	120	5179.959099	5150-5250	PASS
-20	120	5179.962705	5150-5250	PASS

Environment Temperature (°C)	Volage (V)	Measured Frequency (MHz)	limit Range	Test Result
20	108	5179.984423	5150-5250	PASS
	120	5179.998200	5150-5250	PASS
	132	5179.981225	5150-5250	PASS

IEEE 802.11a MHz mode / 5180 ~ 5240MHz (High)

Environment Temperature (°C)	Volage (V)	Measured Frequency (MHz)	limit Range	Test Result
50	120	5239.969169	5150-5250	PASS
40	120	5239.976258	5150-5250	PASS
30	120	5239.971618	5150-5250	PASS
20	120	5240.013000	5150-5250	PASS
10	120	5239.993800	5150-5250	PASS
0	120	5239.992714	5150-5250	PASS
-10	120	5239.978795	5150-5250	PASS
-20	120	5239.979260	5150-5250	PASS

Environment Temperature (°C)	Volage (V)	Measured Frequency (MHz)	limit Range	Test Result
20	108	5239.971123	5150-5250	PASS
	120	5240.013000	5150-5250	PASS
	132	5239.975053	5150-5250	PASS



**IEEE 802.11a mode / 5260 ~ 5320MHz (Low)**

Environment Temperature (°C)	Volage (V)	Measured Frequency (MHz)	limit Range	Test Result
50	120	5259.955973	5250-5350	PASS
40	120	5259.961299	5250-5350	PASS
30	120	5259.949444	5250-5350	PASS
20	120	5260.000200	5250-5350	PASS
10	120	5259.960059	5250-5350	PASS
0	120	5259.976324	5250-5350	PASS
-10	120	5259.952016	5250-5350	PASS
-20	120	5259.994771	5250-5350	PASS

Environment Temperature (°C)	Volage (V)	Measured Frequency (MHz)	limit Range	Test Result
20	108	5259.970785	5250-5350	PASS
	120	5260.000200	5250-5350	PASS
	132	5259.969136	5250-5350	PASS

**IEEE 802.11a mode / 5260 ~ 5320MHz (High)**

Environment Temperature (°C)	Volage (V)	Measured Frequency (MHz)	limit Range	Test Result
50	120	5319.982267	5250-5350	PASS
40	120	5319.955818	5250-5350	PASS
30	120	5319.977476	5250-5350	PASS
20	120	5320.007000	5250-5350	PASS
10	120	5319.958462	5250-5350	PASS
0	120	5319.967670	5250-5350	PASS
-10	120	5319.951583	5250-5350	PASS
-20	120	5319.994430	5250-5350	PASS

Environment Temperature (°C)	Volage (V)	Measured Frequency (MHz)	limit Range	Test Result
20	108	5319.967555	5250-5350	PASS
	120	5320.007000	5250-5350	PASS
	132	5319.992492	5250-5350	PASS



**IEEE 802.11a mode / 5500 ~ 5700MHz (Low)**

Environment Temperature (°C)	Volage (V)	Measured Frequency (MHz)	limit Range	Test Result
50	120	5499.955582	5475-5725	PASS
40	120	5499.989557	5475-5725	PASS
30	120	5499.989437	5475-5725	PASS
20	120	5500.007000	5475-5725	PASS
10	120	5499.958880	5475-5725	PASS
0	120	5499.991618	5475-5725	PASS
-10	120	5499.982153	5475-5725	PASS
-20	120	5499.986518	5475-5725	PASS

Environment Temperature (°C)	Volage (V)	Measured Frequency (MHz)	limit Range	Test Result
20	108	5499.977207	5475-5725	PASS
	120	5500.007000	5475-5725	PASS
	132	5499.966373	5475-5725	PASS

**IEEE 802.11a mode / 5500 ~ 5700MHz (High)**

Environment Temperature (°C)	Volage (V)	Measured Frequency (MHz)	limit Range	Test Result
50	120	5699.951824	5475-5725	PASS
40	120	5699.970134	5475-5725	PASS
30	120	5699.983849	5475-5725	PASS
20	120	5699.998600	5475-5725	PASS
10	120	5699.968762	5475-5725	PASS
0	120	5699.984361	5475-5725	PASS
-10	120	5699.983986	5475-5725	PASS
-20	120	5699.968827	5475-5725	PASS

Environment Temperature (°C)	Volage (V)	Measured Frequency (MHz)	limit Range	Test Result
20	108	5699.969652	5475-5725	PASS
	120	5699.998600	5475-5725	PASS
	132	5699.970329	5475-5725	PASS





**IEEE 802.11a mode / 5745 ~ 5825MHz (Low)**

Environment Temperature (°C)	Volage (V)	Measured Frequency (MHz)	limit Range	Test Result
50	120	5744.956551	5725-5850	PASS
40	120	5744.952200	5725-5850	PASS
30	120	5744.994198	5725-5850	PASS
20	120	5744.998265	5725-5850	PASS
10	120	5744.979501	5725-5850	PASS
0	120	5744.978390	5725-5850	PASS
-10	120	5744.963206	5725-5850	PASS
-20	120	5744.961202	5725-5850	PASS

Environment Temperature (°C)	Volage (V)	Measured Frequency (MHz)	limit Range	Test Result
20	108	5744.986055	5725-5850	PASS
	120	5744.998265	5725-5850	PASS
	132	5744.977264	5725-5850	PASS

**IEEE 802.11a mode / 5745 ~ 5825MHz (High)**

Environment Temperature (°C)	Volage (V)	Measured Frequency (MHz)	limit Range	Test Result
50	120	5824.966233	5725-5850	PASS
40	120	5824.962256	5725-5850	PASS
30	120	5824.985791	5725-5850	PASS
20	120	5824.996270	5725-5850	PASS
10	120	5824.977875	5725-5850	PASS
0	120	5824.984923	5725-5850	PASS
-10	120	5824.982607	5725-5850	PASS
-20	120	5824.959333	5725-5850	PASS

Environment Temperature (°C)	Volage (V)	Measured Frequency (MHz)	limit Range	Test Result
20	108	5824.976029	5725-5850	PASS
	120	5824.996270	5725-5850	PASS
	132	5824.958476	5725-5850	PASS



Antenna 1

IEEE 802.11a MHz mode / 5180 ~ 5240MHz (Low)

Environment Temperature (°C)	Volage (V)	Measured Frequency (MHz)	limit Range	Test Result
50	120	5179.950474	5150-5250	PASS
40	120	5179.958824	5150-5250	PASS
30	120	5179.968095	5150-5250	PASS
20	120	5179.993000	5150-5250	PASS
10	120	5179.984020	5150-5250	PASS
0	120	5179.980774	5150-5250	PASS
-10	120	5179.997205	5150-5250	PASS
-20	120	5179.995601	5150-5250	PASS

Environment Temperature (°C)	Volage (V)	Measured Frequency (MHz)	limit Range	Test Result
20	108	5179.952215	5150-5250	PASS
	120	5179.993000	5150-5250	PASS
	132	5179.969986	5150-5250	PASS

IEEE 802.11a MHz mode / 5180 ~ 5240MHz (High)

Environment Temperature (°C)	Volage (V)	Measured Frequency (MHz)	limit Range	Test Result
50	120	5239.979136	5150-5250	PASS
40	120	5239.973907	5150-5250	PASS
30	120	5239.998969	5150-5250	PASS
20	120	5240.001500	5150-5250	PASS
10	120	5239.951451	5150-5250	PASS
0	120	5239.995994	5150-5250	PASS
-10	120	5239.982929	5150-5250	PASS
-20	120	5239.986254	5150-5250	PASS

Environment Temperature (°C)	Volage (V)	Measured Frequency (MHz)	limit Range	Test Result
20	108	5239.987506	5150-5250	PASS
	120	5240.001500	5150-5250	PASS
	132	5239.953787	5150-5250	PASS



IEEE 802.11a mode / 5260 ~ 5320MHz (Low)

Environment Temperature (°C)	Volage (V)	Measured Frequency (MHz)	limit Range	Test Result
50	120	5259.953006	5250-5350	PASS
40	120	5259.977231	5250-5350	PASS
30	120	5259.973167	5250-5350	PASS
20	120	5260.002000	5250-5350	PASS
10	120	5259.964351	5250-5350	PASS
0	120	5259.984432	5250-5350	PASS
-10	120	5259.951920	5250-5350	PASS
-20	120	5259.978117	5250-5350	PASS

Environment Temperature (°C)	Volage (V)	Measured Frequency (MHz)	limit Range	Test Result
20	108	5259.949287	5250-5350	PASS
	120	5260.002000	5250-5350	PASS
	132	5259.957209	5250-5350	PASS

IEEE 802.11a mode / 5260 ~ 5320MHz (High)

Environment Temperature (°C)	Volage (V)	Measured Frequency (MHz)	limit Range	Test Result
50	120	5319.955663	5250-5350	PASS
40	120	5319.972036	5250-5350	PASS
30	120	5319.968327	5250-5350	PASS
20	120	5320.002400	5250-5350	PASS
10	120	5319.959703	5250-5350	PASS
0	120	5319.997129	5250-5350	PASS
-10	120	5319.971157	5250-5350	PASS
-20	120	5319.958083	5250-5350	PASS

Environment Temperature (°C)	Volage (V)	Measured Frequency (MHz)	limit Range	Test Result
20	108	5319.981539	5250-5350	PASS
	120	5320.002400	5250-5350	PASS
	132	5319.968760	5250-5350	PASS



**IEEE 802.11a mode / 5500 ~ 5700MHz (Low)**

Environment Temperature (°C)	Volage (V)	Measured Frequency (MHz)	limit Range	Test Result
50	120	5499.985506	5475-5725	PASS
40	120	5499.972271	5475-5725	PASS
30	120	5499.993324	5475-5725	PASS
20	120	5500.008000	5475-5725	PASS
10	120	5499.954693	5475-5725	PASS
0	120	5499.954757	5475-5725	PASS
-10	120	5499.973658	5475-5725	PASS
-20	120	5499.966647	5475-5725	PASS

Environment Temperature (°C)	Volage (V)	Measured Frequency (MHz)	limit Range	Test Result
20	108	5499.998776	5475-5725	PASS
	120	5500.008000	5475-5725	PASS
	132	5499.993225	5475-5725	PASS

**IEEE 802.11a mode / 5500 ~ 5700MHz (High)**

Environment Temperature (°C)	Volage (V)	Measured Frequency (MHz)	limit Range	Test Result
50	120	5699.989265	5475-5725	PASS
40	120	5699.968928	5475-5725	PASS
30	120	5699.974658	5475-5725	PASS
20	120	5699.998100	5475-5725	PASS
10	120	5699.990391	5475-5725	PASS
0	120	5699.979828	5475-5725	PASS
-10	120	5699.974324	5475-5725	PASS
-20	120	5699.981552	5475-5725	PASS

Environment Temperature (°C)	Volage (V)	Measured Frequency (MHz)	limit Range	Test Result
20	108	5699.980177	5475-5725	PASS
	120	5699.998100	5475-5725	PASS
	132	5699.991673	5475-5725	PASS



**IEEE 802.11a mode / 5745 ~ 5825MHz (Low)**

Environment Temperature (°C)	Volage (V)	Measured Frequency (MHz)	limit Range	Test Result
50	120	5744.995278	5725-5850	PASS
40	120	5744.954151	5725-5850	PASS
30	120	5744.963934	5725-5850	PASS
20	120	5744.998580	5725-5850	PASS
10	120	5744.985069	5725-5850	PASS
0	120	5744.994248	5725-5850	PASS
-10	120	5744.960245	5725-5850	PASS
-20	120	5744.964829	5725-5850	PASS

Environment Temperature (°C)	Volage (V)	Measured Frequency (MHz)	limit Range	Test Result
20	108	5744.951595	5725-5850	PASS
	120	5744.998580	5725-5850	PASS
	132	5744.984480	5725-5850	PASS

**IEEE 802.11a mode / 5745 ~ 5825MHz (High)**

Environment Temperature (°C)	Volage (V)	Measured Frequency (MHz)	limit Range	Test Result
50	120	5824.973551	5725-5850	PASS
40	120	5824.981407	5725-5850	PASS
30	120	5824.969608	5725-5850	PASS
20	120	5824.996570	5725-5850	PASS
10	120	5824.991853	5725-5850	PASS
0	120	5824.997786	5725-5850	PASS
-10	120	5824.955302	5725-5850	PASS
-20	120	5824.987482	5725-5850	PASS

Environment Temperature (°C)	Volage (V)	Measured Frequency (MHz)	limit Range	Test Result
20	108	5824.987518	5725-5850	PASS
	120	5824.996570	5725-5850	PASS
	132	5824.975898	5725-5850	PASS



Antenna 0

IEEE 802.11n HT 20 MHz mode / 5180 ~ 5240MHz (Low)

Environment Temperature (°C)	Volage (V)	Measured Frequency (MHz)	limit Range	Test Result
50	120	5179.992443	5150-5250	PASS
40	120	5179.958610	5150-5250	PASS
30	120	5179.960465	5150-5250	PASS
20	120	5179.999100	5150-5250	PASS
10	120	5179.953919	5150-5250	PASS
0	120	5179.969593	5150-5250	PASS
-10	120	5179.968937	5150-5250	PASS
-20	120	5179.986683	5150-5250	PASS

Environment Temperature (°C)	Volage (V)	Measured Frequency (MHz)	limit Range	Test Result
20	108	5179.961213	5150-5250	PASS
	120	5179.999100	5150-5250	PASS
	132	5179.966882	5150-5250	PASS

IEEE 802.11n HT 20 MHz mode / 5180 ~ 5240MHz (High)

Environment Temperature (°C)	Volage (V)	Measured Frequency (MHz)	limit Range	Test Result
50	120	5239.952434	5150-5250	PASS
40	120	5239.998000	5150-5250	PASS
30	120	5239.967196	5150-5250	PASS
20	120	5239.999000	5150-5250	PASS
10	120	5239.950968	5150-5250	PASS
0	120	5239.980328	5150-5250	PASS
-10	120	5239.984648	5150-5250	PASS
-20	120	5239.959858	5150-5250	PASS

Environment Temperature (°C)	Volage (V)	Measured Frequency (MHz)	limit Range	Test Result
20	108	5239.967631	5150-5250	PASS
	120	5239.999000	5150-5250	PASS
	132	5239.970532	5150-5250	PASS



**IEEE 802.11n HT 20 MHz mode / 5260 ~ 5320MHz (Low)**

Environment Temperature (°C)	Volage (V)	Measured Frequency (MHz)	limit Range	Test Result
50	120	5259.982980	5250-5350	PASS
40	120	5259.954816	5250-5350	PASS
30	120	5259.955154	5250-5350	PASS
20	120	5259.998500	5250-5350	PASS
10	120	5259.995868	5250-5350	PASS
0	120	5259.961437	5250-5350	PASS
-10	120	5259.960921	5250-5350	PASS
-20	120	5259.981382	5250-5350	PASS

Environment Temperature (°C)	Volage (V)	Measured Frequency (MHz)	limit Range	Test Result
20	108	5259.974288	5250-5350	PASS
	120	5259.998500	5250-5350	PASS
	132	5259.995623	5250-5350	PASS

**IEEE 802.11n HT 20 MHz mode / 5260 ~ 5320MHz (High)**

Environment Temperature (°C)	Volage (V)	Measured Frequency (MHz)	limit Range	Test Result
50	120	5319.988806	5250-5350	PASS
40	120	5319.971342	5250-5350	PASS
30	120	5319.949116	5250-5350	PASS
20	120	5319.998300	5250-5350	PASS
10	120	5319.964509	5250-5350	PASS
0	120	5319.987171	5250-5350	PASS
-10	120	5319.983129	5250-5350	PASS
-20	120	5319.961060	5250-5350	PASS

Environment Temperature (°C)	Volage (V)	Measured Frequency (MHz)	limit Range	Test Result
20	108	5319.977823	5250-5350	PASS
	120	5319.998300	5250-5350	PASS
	132	5319.951123	5250-5350	PASS



**IEEE 802.11n HT 20 MHz mode / 5500 ~ 5700MHz (Low)**

Environment Temperature (°C)	Volage (V)	Measured Frequency (MHz)	limit Range	Test Result
50	120	5499.965507	5475-5725	PASS
40	120	5499.971783	5475-5725	PASS
30	120	5499.964188	5475-5725	PASS
20	120	5499.998600	5475-5725	PASS
10	120	5499.975301	5475-5725	PASS
0	120	5499.959648	5475-5725	PASS
-10	120	5499.978440	5475-5725	PASS
-20	120	5499.976439	5475-5725	PASS

Environment Temperature (°C)	Volage (V)	Measured Frequency (MHz)	limit Range	Test Result
20	108	5499.981879	5475-5725	PASS
	120	5499.998600	5475-5725	PASS
	132	5499.971046	5475-5725	PASS

**IEEE 802.11n HT 20 MHz mode / 5500 ~ 5700MHz (High)**

Environment Temperature (°C)	Volage (V)	Measured Frequency (MHz)	limit Range	Test Result
50	120	5699.986161	5475-5725	PASS
40	120	5699.971316	5475-5725	PASS
30	120	5699.975512	5475-5725	PASS
20	120	5699.998700	5475-5725	PASS
10	120	5699.965439	5475-5725	PASS
0	120	5699.972429	5475-5725	PASS
-10	120	5699.987120	5475-5725	PASS
-20	120	5699.975948	5475-5725	PASS

Environment Temperature (°C)	Volage (V)	Measured Frequency (MHz)	limit Range	Test Result
20	108	5699.957209	5475-5725	PASS
	120	5699.998700	5475-5725	PASS
	132	5699.980731	5475-5725	PASS





**IEEE 802.11n HT 20 MHz mode / 5745 ~ 5825MHz (Low)**

Environment Temperature (°C)	Volage (V)	Measured Frequency (MHz)	limit Range	Test Result
50	120	5744.961840	5725-5850	PASS
40	120	5744.978671	5725-5850	PASS
30	120	5744.987443	5725-5850	PASS
20	120	5744.998210	5725-5850	PASS
10	120	5744.976109	5725-5850	PASS
0	120	5744.957068	5725-5850	PASS
-10	120	5744.959135	5725-5850	PASS
-20	120	5744.998253	5725-5850	PASS

Environment Temperature (°C)	Volage (V)	Measured Frequency (MHz)	limit Range	Test Result
20	108	5744.954594	5725-5850	PASS
	120	5744.998210	5725-5850	PASS
	132	5744.961010	5725-5850	PASS

**IEEE 802.11n HT 20 MHz mode / 5745 ~ 5825MHz (High)**

Environment Temperature (°C)	Volage (V)	Measured Frequency (MHz)	limit Range	Test Result
50	120	5824.949124	5725-5850	PASS
40	120	5824.960091	5725-5850	PASS
30	120	5824.962657	5725-5850	PASS
20	120	5824.997810	5725-5850	PASS
10	120	5824.989824	5725-5850	PASS
0	120	5824.959044	5725-5850	PASS
-10	120	5824.956563	5725-5850	PASS
-20	120	5824.983949	5725-5850	PASS

Environment Temperature (°C)	Volage (V)	Measured Frequency (MHz)	limit Range	Test Result
20	108	5824.997990	5725-5850	PASS
	120	5824.997810	5725-5850	PASS
	132	5824.999575	5725-5850	PASS



Antenna 1

IEEE 802.11n HT 20 MHz mode / 5180 ~ 5240MHz (Low)

Environment Temperature (°C)	Volage (V)	Measured Frequency (MHz)	limit Range	Test Result
50	120	5179.970404	5150-5250	PASS
40	120	5179.983839	5150-5250	PASS
30	120	5179.981095	5150-5250	PASS
20	120	5179.998100	5150-5250	PASS
10	120	5179.965682	5150-5250	PASS
0	120	5179.979150	5150-5250	PASS
-10	120	5179.961738	5150-5250	PASS
-20	120	5179.982579	5150-5250	PASS

Environment Temperature (°C)	Volage (V)	Measured Frequency (MHz)	limit Range	Test Result
20	108	5179.964720	5150-5250	PASS
	120	5179.998100	5150-5250	PASS
	132	5179.986789	5150-5250	PASS

IEEE 802.11n HT 20 MHz mode / 5180 ~ 5240MHz (High)

Environment Temperature (°C)	Volage (V)	Measured Frequency (MHz)	limit Range	Test Result
50	120	5239.991516	5150-5250	PASS
40	120	5239.987749	5150-5250	PASS
30	120	5239.976136	5150-5250	PASS
20	120	5240.001600	5150-5250	PASS
10	120	5239.970942	5150-5250	PASS
0	120	5239.950725	5150-5250	PASS
-10	120	5239.979098	5150-5250	PASS
-20	120	5239.949796	5150-5250	PASS

Environment Temperature (°C)	Volage (V)	Measured Frequency (MHz)	limit Range	Test Result
20	108	5239.950101	5150-5250	PASS
	120	5240.001600	5150-5250	PASS
	132	5239.975904	5150-5250	PASS



**IEEE 802.11n HT 20 MHz mode / 5260 ~ 5320MHz (Low)**

Environment Temperature (°C)	Volage (V)	Measured Frequency (MHz)	limit Range	Test Result
50	120	5259.984482	5250-5350	PASS
40	120	5259.980711	5250-5350	PASS
30	120	5259.965826	5250-5350	PASS
20	120	5259.996200	5250-5350	PASS
10	120	5259.953601	5250-5350	PASS
0	120	5259.961407	5250-5350	PASS
-10	120	5259.964752	5250-5350	PASS
-20	120	5259.959921	5250-5350	PASS

Environment Temperature (°C)	Volage (V)	Measured Frequency (MHz)	limit Range	Test Result
20	108	5259.986470	5250-5350	PASS
	120	5259.996200	5250-5350	PASS
	132	5259.967817	5250-5350	PASS

**IEEE 802.11n HT 20 MHz mode / 5260 ~ 5320MHz (High)**

Environment Temperature (°C)	Volage (V)	Measured Frequency (MHz)	limit Range	Test Result
50	120	5319.969334	5250-5350	PASS
40	120	5319.997557	5250-5350	PASS
30	120	5319.956256	5250-5350	PASS
20	120	5319.998100	5250-5350	PASS
10	120	5319.958406	5250-5350	PASS
0	120	5319.950011	5250-5350	PASS
-10	120	5319.981549	5250-5350	PASS
-20	120	5319.973463	5250-5350	PASS

Environment Temperature (°C)	Volage (V)	Measured Frequency (MHz)	limit Range	Test Result
20	108	5319.997164	5250-5350	PASS
	120	5319.998100	5250-5350	PASS
	132	5319.997541	5250-5350	PASS



**IEEE 802.11n HT 20 MHz mode / 5500 ~ 5700MHz (Low)**

Environment Temperature (°C)	Volage (V)	Measured Frequency (MHz)	limit Range	Test Result
50	120	5499.958485	5475-5725	PASS
40	120	5499.995622	5475-5725	PASS
30	120	5499.975015	5475-5725	PASS
20	120	5499.998700	5475-5725	PASS
10	120	5499.994978	5475-5725	PASS
0	120	5499.974297	5475-5725	PASS
-10	120	5499.977905	5475-5725	PASS
-20	120	5499.992945	5475-5725	PASS

Environment Temperature (°C)	Volage (V)	Measured Frequency (MHz)	limit Range	Test Result
20	108	5499.985898	5475-5725	PASS
	120	5499.998700	5475-5725	PASS
	132	5499.989968	5475-5725	PASS

**IEEE 802.11n HT 20 MHz mode / 5500 ~ 5700MHz (High)**

Environment Temperature (°C)	Volage (V)	Measured Frequency (MHz)	limit Range	Test Result
50	120	5699.951563	5475-5725	PASS
40	120	5699.950223	5475-5725	PASS
30	120	5699.978857	5475-5725	PASS
20	120	5699.997600	5475-5725	PASS
10	120	5699.980347	5475-5725	PASS
0	120	5699.982716	5475-5725	PASS
-10	120	5699.995091	5475-5725	PASS
-20	120	5699.974032	5475-5725	PASS

Environment Temperature (°C)	Volage (V)	Measured Frequency (MHz)	limit Range	Test Result
20	108	5699.962543	5475-5725	PASS
	120	5699.997600	5475-5725	PASS
	132	5699.955527	5475-5725	PASS



**IEEE 802.11n HT 20 MHz mode / 5745 ~ 5825MHz (Low)**

Environment Temperature (°C)	Volage (V)	Measured Frequency (MHz)	limit Range	Test Result
50	120	5744.983624	5725-5850	PASS
40	120	5744.958544	5725-5850	PASS
30	120	5744.957626	5725-5850	PASS
20	120	5744.998500	5725-5850	PASS
10	120	5744.994648	5725-5850	PASS
0	120	5744.951106	5725-5850	PASS
-10	120	5744.995841	5725-5850	PASS
-20	120	5744.985362	5725-5850	PASS

Environment Temperature (°C)	Volage (V)	Measured Frequency (MHz)	limit Range	Test Result
20	108	5744.956300	5725-5850	PASS
	120	5744.998500	5725-5850	PASS
	132	5744.992653	5725-5850	PASS

**IEEE 802.11n HT 20 MHz mode / 5745 ~ 5825MHz (High)**

Environment Temperature (°C)	Volage (V)	Measured Frequency (MHz)	limit Range	Test Result
50	120	5824.982437	5725-5850	PASS
40	120	5824.987130	5725-5850	PASS
30	120	5824.982961	5725-5850	PASS
20	120	5824.998300	5725-5850	PASS
10	120	5824.963255	5725-5850	PASS
0	120	5824.959335	5725-5850	PASS
-10	120	5824.994449	5725-5850	PASS
-20	120	5824.999597	5725-5850	PASS

Environment Temperature (°C)	Volage (V)	Measured Frequency (MHz)	limit Range	Test Result
20	108	5824.973742	5725-5850	PASS
	120	5824.998300	5725-5850	PASS
	132	5824.972591	5725-5850	PASS



Antenna 0

IEEE 802.11n HT 40 MHz mode / 5190 ~ 5230MHz (Low)

Environment Temperature (°C)	Volage (V)	Measured Frequency (MHz)	limit Range	Test Result
50	120	5189.958158	5150-5250	PASS
40	120	5189.966029	5150-5250	PASS
30	120	5189.980695	5150-5250	PASS
20	120	5189.999800	5150-5250	PASS
10	120	5189.962150	5150-5250	PASS
0	120	5189.953113	5150-5250	PASS
-10	120	5189.965591	5150-5250	PASS
-20	120	5189.970095	5150-5250	PASS

Environment Temperature (°C)	Volage (V)	Measured Frequency (MHz)	limit Range	Test Result
20	108	5189.988266	5150-5250	PASS
	120	5189.999800	5150-5250	PASS
	132	5189.956631	5150-5250	PASS

IEEE 802.11n HT 40 MHz mode / 5190 ~ 5230MHz (High)

Environment Temperature (°C)	Volage (V)	Measured Frequency (MHz)	limit Range	Test Result
50	120	5229.984009	5150-5250	PASS
40	120	5229.995537	5150-5250	PASS
30	120	5229.970397	5150-5250	PASS
20	120	5230.001500	5150-5250	PASS
10	120	5229.978831	5150-5250	PASS
0	120	5229.993677	5150-5250	PASS
-10	120	5229.978056	5150-5250	PASS
-20	120	5229.972035	5150-5250	PASS

Environment Temperature (°C)	Volage (V)	Measured Frequency (MHz)	limit Range	Test Result
20	108	5229.998693	5150-5250	PASS
	120	5230.001500	5150-5250	PASS
	132	5229.977411	5150-5250	PASS



**IEEE 802.11n HT 40 MHz mode / 5270 ~ 5310MHz (Low)**

Environment Temperature (°C)	Volage (V)	Measured Frequency (MHz)	limit Range	Test Result
50	120	5269.956784	5250-5350	PASS
40	120	5269.998326	5250-5350	PASS
30	120	5269.991414	5250-5350	PASS
20	120	5270.003000	5250-5350	PASS
10	120	5269.974801	5250-5350	PASS
0	120	5269.984953	5250-5350	PASS
-10	120	5269.980353	5250-5350	PASS
-20	120	5269.967299	5250-5350	PASS

Environment Temperature (°C)	Volage (V)	Measured Frequency (MHz)	limit Range	Test Result
20	108	5269.990576	5250-5350	PASS
	120	5270.003000	5250-5350	PASS
	132	5269.955875	5250-5350	PASS

**IEEE 802.11n HT 40 MHz mode / 5270 ~ 5310MHz (High)**

Environment Temperature (°C)	Volage (V)	Measured Frequency (MHz)	limit Range	Test Result
50	120	5309.986038	5250-5350	PASS
40	120	5309.988328	5250-5350	PASS
30	120	5309.985733	5250-5350	PASS
20	120	5310.024000	5250-5350	PASS
10	120	5309.997203	5250-5350	PASS
0	120	5309.986101	5250-5350	PASS
-10	120	5309.997400	5250-5350	PASS
-20	120	5309.973052	5250-5350	PASS

Environment Temperature (°C)	Volage (V)	Measured Frequency (MHz)	limit Range	Test Result
20	108	5309.951649	5250-5350	PASS
	120	5310.024000	5250-5350	PASS
	132	5309.974438	5250-5350	PASS



**IEEE 802.11n HT 40 MHz mode / 5510 ~ 5670MHz (Low)**

Environment Temperature (°C)	Volage (V)	Measured Frequency (MHz)	limit Range	Test Result
50	120	5509.963588	5475-5725	PASS
40	120	5509.994299	5475-5725	PASS
30	120	5509.997820	5475-5725	PASS
20	120	5510.001000	5475-5725	PASS
10	120	5509.984783	5475-5725	PASS
0	120	5509.968889	5475-5725	PASS
-10	120	5509.987611	5475-5725	PASS
-20	120	5509.953190	5475-5725	PASS

Environment Temperature (°C)	Volage (V)	Measured Frequency (MHz)	limit Range	Test Result
20	108	5509.974519	5475-5725	PASS
	120	5510.001000	5475-5725	PASS
	132	5509.961395	5475-5725	PASS

**IEEE 802.11n HT 40 MHz mode / 5510 ~ 5670MHz (High)**

Environment Temperature (°C)	Volage (V)	Measured Frequency (MHz)	limit Range	Test Result
50	120	5669.980119	5475-5725	PASS
40	120	5669.959281	5475-5725	PASS
30	120	5669.997309	5475-5725	PASS
20	120	5670.002100	5475-5725	PASS
10	120	5669.951154	5475-5725	PASS
0	120	5669.989064	5475-5725	PASS
-10	120	5669.972576	5475-5725	PASS
-20	120	5669.996775	5475-5725	PASS

Environment Temperature (°C)	Volage (V)	Measured Frequency (MHz)	limit Range	Test Result
20	108	5669.969911	5475-5725	PASS
	120	5670.002100	5475-5725	PASS
	132	5669.973896	5475-5725	PASS





**IEEE 802.11n HT 40 MHz mode / 5755 ~ 5795MHz (Low)**

Environment Temperature (°C)	Volage (V)	Measured Frequency (MHz)	limit Range	Test Result
50	120	5754.992974	5725-5850	PASS
40	120	5754.954354	5725-5850	PASS
30	120	5754.959639	5725-5850	PASS
20	120	5754.997980	5725-5850	PASS
10	120	5754.987974	5725-5850	PASS
0	120	5754.964615	5725-5850	PASS
-10	120	5754.997260	5725-5850	PASS
-20	120	5754.959799	5725-5850	PASS

Environment Temperature (°C)	Volage (V)	Measured Frequency (MHz)	limit Range	Test Result
20	108	5754.970953	5725-5850	PASS
	120	5754.997980	5725-5850	PASS
	132	5754.972956	5725-5850	PASS

**IEEE 802.11n HT 40 MHz mode / 5755 ~ 5795MHz (High)**

Environment Temperature (°C)	Volage (V)	Measured Frequency (MHz)	limit Range	Test Result
50	120	5794.976122	5725-5850	PASS
40	120	5794.974019	5725-5850	PASS
30	120	5794.990240	5725-5850	PASS
20	120	5794.997700	5725-5850	PASS
10	120	5794.952031	5725-5850	PASS
0	120	5794.991721	5725-5850	PASS
-10	120	5794.973579	5725-5850	PASS
-20	120	5794.955889	5725-5850	PASS

Environment Temperature (°C)	Volage (V)	Measured Frequency (MHz)	limit Range	Test Result
20	108	5794.984096	5725-5850	PASS
	120	5794.997700	5725-5850	PASS
	132	5794.966924	5725-5850	PASS



Antenna 1

IEEE 802.11n HT 40 MHz mode / 5190 ~ 5230MHz (Low)

Environment Temperature (°C)	Volage (V)	Measured Frequency (MHz)	limit Range	Test Result
50	120	5189.949101	5150-5250	PASS
40	120	5189.962646	5150-5250	PASS
30	120	5189.993180	5150-5250	PASS
20	120	5189.999700	5150-5250	PASS
10	120	5189.961016	5150-5250	PASS
0	120	5189.999359	5150-5250	PASS
-10	120	5189.971008	5150-5250	PASS
-20	120	5189.970470	5150-5250	PASS

Environment Temperature (°C)	Volage (V)	Measured Frequency (MHz)	limit Range	Test Result
20	108	5189.994678	5150-5250	PASS
	120	5189.999700	5150-5250	PASS
	132	5189.995570	5150-5250	PASS

IEEE 802.11n HT 40 MHz mode / 5190 ~ 5230MHz (High)

Environment Temperature (°C)	Volage (V)	Measured Frequency (MHz)	limit Range	Test Result
50	120	5229.976254	5150-5250	PASS
40	120	5229.959595	5150-5250	PASS
30	120	5229.990514	5150-5250	PASS
20	120	5230.001500	5150-5250	PASS
10	120	5229.987728	5150-5250	PASS
0	120	5229.956618	5150-5250	PASS
-10	120	5229.950289	5150-5250	PASS
-20	120	5229.958547	5150-5250	PASS

Environment Temperature (°C)	Volage (V)	Measured Frequency (MHz)	limit Range	Test Result
20	108	5229.995625	5150-5250	PASS
	120	5230.001500	5150-5250	PASS
	132	5229.967121	5150-5250	PASS



**IEEE 802.11n HT 40 MHz mode / 5270 ~ 5310MHz (Low)**

Environment Temperature (°C)	Volage (V)	Measured Frequency (MHz)	limit Range	Test Result
50	120	5269.962288	5250-5350	PASS
40	120	5269.954374	5250-5350	PASS
30	120	5269.994917	5250-5350	PASS
20	120	5270.001000	5250-5350	PASS
10	120	5269.980799	5250-5350	PASS
0	120	5269.968933	5250-5350	PASS
-10	120	5269.960046	5250-5350	PASS
-20	120	5269.950203	5250-5350	PASS

Environment Temperature (°C)	Volage (V)	Measured Frequency (MHz)	limit Range	Test Result
20	108	5269.999163	5250-5350	PASS
	120	5270.001000	5250-5350	PASS
	132	5269.976282	5250-5350	PASS

**IEEE 802.11n HT 40 MHz mode / 5270 ~ 5310MHz (High)**

Environment Temperature (°C)	Volage (V)	Measured Frequency (MHz)	limit Range	Test Result
50	120	5309.977020	5250-5350	PASS
40	120	5309.969727	5250-5350	PASS
30	120	5309.956454	5250-5350	PASS
20	120	5310.021000	5250-5350	PASS
10	120	5309.992419	5250-5350	PASS
0	120	5309.960854	5250-5350	PASS
-10	120	5309.966937	5250-5350	PASS
-20	120	5309.967293	5250-5350	PASS

Environment Temperature (°C)	Volage (V)	Measured Frequency (MHz)	limit Range	Test Result
20	108	5309.955583	5250-5350	PASS
	120	5310.021000	5250-5350	PASS
	132	5309.990198	5250-5350	PASS



**IEEE 802.11n HT 40 MHz mode / 5510 ~ 5670MHz (Low)**

Environment Temperature (°C)	Volage (V)	Measured Frequency (MHz)	limit Range	Test Result
50	120	5509.992621	5475-5725	PASS
40	120	5509.997235	5475-5725	PASS
30	120	5509.991669	5475-5725	PASS
20	120	5510.003000	5475-5725	PASS
10	120	5509.974864	5475-5725	PASS
0	120	5509.963530	5475-5725	PASS
-10	120	5509.987130	5475-5725	PASS
-20	120	5509.991211	5475-5725	PASS

Environment Temperature (°C)	Volage (V)	Measured Frequency (MHz)	limit Range	Test Result
20	108	5509.994520	5475-5725	PASS
	120	5510.003000	5475-5725	PASS
	132	5509.953921	5475-5725	PASS

**IEEE 802.11n HT 40 MHz mode / 5510 ~ 5670MHz (High)**

Environment Temperature (°C)	Volage (V)	Measured Frequency (MHz)	limit Range	Test Result
50	120	5669.959917	5475-5725	PASS
40	120	5669.972302	5475-5725	PASS
30	120	5669.965779	5475-5725	PASS
20	120	5670.002800	5475-5725	PASS
10	120	5669.955867	5475-5725	PASS
0	120	5669.958759	5475-5725	PASS
-10	120	5669.995988	5475-5725	PASS
-20	120	5669.996193	5475-5725	PASS

Environment Temperature (°C)	Volage (V)	Measured Frequency (MHz)	limit Range	Test Result
20	108	5669.950209	5475-5725	PASS
	120	5670.002800	5475-5725	PASS
	132	5669.954948	5475-5725	PASS



**IEEE 802.11n HT 40 MHz mode / 5755 ~ 5795MHz (Low)**

Environment Temperature (°C)	Volage (V)	Measured Frequency (MHz)	limit Range	Test Result
50	120	5754.978077	5725-5850	PASS
40	120	5754.956790	5725-5850	PASS
30	120	5754.997105	5725-5850	PASS
20	120	5754.997910	5725-5850	PASS
10	120	5754.970979	5725-5850	PASS
0	120	5754.987395	5725-5850	PASS
-10	120	5754.984668	5725-5850	PASS
-20	120	5754.980121	5725-5850	PASS

Environment Temperature (°C)	Volage (V)	Measured Frequency (MHz)	limit Range	Test Result
20	108	5754.976912	5725-5850	PASS
	120	5754.997910	5725-5850	PASS
	132	5754.972491	5725-5850	PASS

**IEEE 802.11n HT 40 MHz mode / 5755 ~ 5795MHz (High)**

Environment Temperature (°C)	Volage (V)	Measured Frequency (MHz)	limit Range	Test Result
50	120	5794.992457	5725-5850	PASS
40	120	5794.989483	5725-5850	PASS
30	120	5794.955549	5725-5850	PASS
20	120	5794.998300	5725-5850	PASS
10	120	5794.979074	5725-5850	PASS
0	120	5794.967290	5725-5850	PASS
-10	120	5794.964078	5725-5850	PASS
-20	120	5794.965836	5725-5850	PASS

Environment Temperature (°C)	Volage (V)	Measured Frequency (MHz)	limit Range	Test Result
20	108	5794.966312	5725-5850	PASS
	120	5794.998300	5725-5850	PASS
	132	5794.965884	5725-5850	PASS



Antenna 0

IEEE 802.11ac 80 mode / 5210MHz

Environment Temperature (°C)	Volage (V)	Measured Frequency (MHz)	limit Range	Test Result
50	120	5209.970113	5150-5250	PASS
40	120	5209.982308	5150-5250	PASS
30	120	5209.950877	5150-5250	PASS
20	120	5209.998200	5150-5250	PASS
10	120	5209.986993	5150-5250	PASS
0	120	5209.978187	5150-5250	PASS
-10	120	5209.953507	5150-5250	PASS
-20	120	5209.973833	5150-5250	PASS

Environment Temperature (°C)	Volage (V)	Measured Frequency (MHz)	limit Range	Test Result
20	108	5209.987047	5150-5250	PASS
	120	5209.998200	5150-5250	PASS
	132	5209.983441	5150-5250	PASS

IEEE 802.11ac 80 mode / 5290MHz

Environment Temperature (°C)	Volage (V)	Measured Frequency (MHz)	limit Range	Test Result
50	120	5289.981257	5250-5350	PASS
40	120	5289.969999	5250-5350	PASS
30	120	5289.954004	5250-5350	PASS
20	120	5289.997610	5250-5350	PASS
10	120	5289.991479	5250-5350	PASS
0	120	5289.962467	5250-5350	PASS
-10	120	5289.981574	5250-5350	PASS
-20	120	5289.984817	5250-5350	PASS

Environment Temperature (°C)	Volage (V)	Measured Frequency (MHz)	limit Range	Test Result
20	108	5289.960056	5250-5350	PASS
	120	5289.997610	5250-5350	PASS
	132	5289.985516	5250-5350	PASS



**IEEE 802.11ac 80 mode / 5530MHz (Low)**

Environment Temperature (°C)	Volage (V)	Measured Frequency (MHz)	limit Range	Test Result
50	120	5529.999056	5475-5725	PASS
40	120	5529.973419	5475-5725	PASS
30	120	5529.965565	5475-5725	PASS
20	120	5529.998200	5475-5725	PASS
10	120	5529.982554	5475-5725	PASS
0	120	5529.950296	5475-5725	PASS
-10	120	5529.956013	5475-5725	PASS
-20	120	5529.949192	5475-5725	PASS

Environment Temperature (°C)	Volage (V)	Measured Frequency (MHz)	limit Range	Test Result
20	108	5529.965172	5475-5725	PASS
	120	5529.998200	5475-5725	PASS
	132	5529.953784	5475-5725	PASS

**IEEE 802.11ac 80 mode / 5530MHz (High)**

Environment Temperature (°C)	Volage (V)	Measured Frequency (MHz)	limit Range	Test Result
50	120	5609.988842	5475-5725	PASS
40	120	5609.991449	5475-5725	PASS
30	120	5609.979784	5475-5725	PASS
20	120	5609.998610	5475-5725	PASS
10	120	5609.949730	5475-5725	PASS
0	120	5609.961449	5475-5725	PASS
-10	120	5609.965539	5475-5725	PASS
-20	120	5609.988617	5475-5725	PASS

Environment Temperature (°C)	Volage (V)	Measured Frequency (MHz)	limit Range	Test Result
20	108	5609.962825	5475-5725	PASS
	120	5609.998610	5475-5725	PASS
	132	5609.995671	5475-5725	PASS



IEEE 802.11ac 80 mode / 5775MHz

Environment Temperature (°C)	Volage (V)	Measured Frequency (MHz)	limit Range	Test Result
50	120	5774.992055	5725-5850	PASS
40	120	5774.972433	5725-5850	PASS
30	120	5774.952547	5725-5850	PASS
20	120	5774.998100	5725-5850	PASS
10	120	5774.974923	5725-5850	PASS
0	120	5774.990326	5725-5850	PASS
-10	120	5774.973208	5725-5850	PASS
-20	120	5774.958064	5725-5850	PASS

Environment Temperature (°C)	Volage (V)	Measured Frequency (MHz)	limit Range	Test Result
20	108	5774.951444	5725-5850	PASS
	120	5774.998100	5725-5850	PASS
	132	5774.963114	5725-5850	PASS





Antenna 1

IEEE 802.11ac 80 mode / 5210MHz

Environment Temperature (°C)	Volage (V)	Measured Frequency (MHz)	limit Range	Test Result
50	120	5209.988009	5150-5250	PASS
40	120	5209.964549	5150-5250	PASS
30	120	5209.952401	5150-5250	PASS
20	120	5209.998300	5150-5250	PASS
10	120	5209.982077	5150-5250	PASS
0	120	5209.969291	5150-5250	PASS
-10	120	5209.962769	5150-5250	PASS
-20	120	5209.982529	5150-5250	PASS

Environment Temperature (°C)	Volage (V)	Measured Frequency (MHz)	limit Range	Test Result
20	108	5209.961516	5150-5250	PASS
	120	5209.998300	5150-5250	PASS
	132	5209.989353	5150-5250	PASS

IEEE 802.11ac 80 mode / 5290MHz

Environment Temperature (°C)	Volage (V)	Measured Frequency (MHz)	limit Range	Test Result
50	120	5289.982497	5250-5350	PASS
40	120	5289.974520	5250-5350	PASS
30	120	5289.983397	5250-5350	PASS
20	120	5290.002800	5250-5350	PASS
10	120	5289.999376	5250-5350	PASS
0	120	5289.968351	5250-5350	PASS
-10	120	5289.959990	5250-5350	PASS
-20	120	5289.996908	5250-5350	PASS

Environment Temperature (°C)	Volage (V)	Measured Frequency (MHz)	limit Range	Test Result
20	108	5289.993768	5250-5350	PASS
	120	5290.002800	5250-5350	PASS
	132	5289.966953	5250-5350	PASS



**IEEE 802.11ac 80 mode / 5530MHz (Low)**

Environment Temperature (°C)	Volage (V)	Measured Frequency (MHz)	limit Range	Test Result
50	120	5529.980959	5475-5725	PASS
40	120	5529.975718	5475-5725	PASS
30	120	5529.988899	5475-5725	PASS
20	120	5529.998100	5475-5725	PASS
10	120	5529.970071	5475-5725	PASS
0	120	5529.958903	5475-5725	PASS
-10	120	5529.995722	5475-5725	PASS
-20	120	5529.967049	5475-5725	PASS

Environment Temperature (°C)	Volage (V)	Measured Frequency (MHz)	limit Range	Test Result
20	108	5529.952607	5475-5725	PASS
	120	5529.998100	5475-5725	PASS
	132	5529.970624	5475-5725	PASS

**IEEE 802.11ac 80 mode / 5530MHz (High)**

Environment Temperature (°C)	Volage (V)	Measured Frequency (MHz)	limit Range	Test Result
50	120	5609.956477	5475-5725	PASS
40	120	5609.964817	5475-5725	PASS
30	120	5609.981822	5475-5725	PASS
20	120	5610.003000	5475-5725	PASS
10	120	5609.998474	5475-5725	PASS
0	120	5609.982275	5475-5725	PASS
-10	120	5609.955476	5475-5725	PASS
-20	120	5609.978916	5475-5725	PASS

Environment Temperature (°C)	Volage (V)	Measured Frequency (MHz)	limit Range	Test Result
20	108	5609.956271	5475-5725	PASS
	120	5610.003000	5475-5725	PASS
	132	5609.958651	5475-5725	PASS



**IEEE 802.11ac 80 mode / 5775MHz**

Environment Temperature (°C)	Volage (V)	Measured Frequency (MHz)	limit Range	Test Result
50	120	5774.960490	5725-5850	PASS
40	120	5774.964897	5725-5850	PASS
30	120	5774.981034	5725-5850	PASS
20	120	5774.997300	5725-5850	PASS
10	120	5774.963317	5725-5850	PASS
0	120	5774.954259	5725-5850	PASS
-10	120	5774.996434	5725-5850	PASS
-20	120	5774.983254	5725-5850	PASS

Environment Temperature (°C)	Volage (V)	Measured Frequency (MHz)	limit Range	Test Result
20	108	5774.983346	5725-5850	PASS
	120	5774.997300	5725-5850	PASS
	132	5774.964406	5725-5850	PASS