

RADIO REPORT FCC 47 CFR Part 22H, FCC 47 CFR Part 24E ISED Canada RSS-132 Issue 3, ISED RSS-133, Issue 6 Amendment 1	
Report Reference No	G0M-2108-9942-TFCMOCOGRSE-V01
Testing Laboratory	Eurofins Product Service GmbH
Address	Storkower Str. 38c 15526 Reichenwalde Germany
Accreditation	 <p>DAkkS - Registration number : D-PL-12092-01-03 (ISED) ISED Testing Laboratory site: 3470A DAkkS - Registration number : D-PL-12092-01-04 (FCC) FCC Filed Test Laboratory, Reg.-No.: 96970</p>
Applicant	Bridgestone Mobility Solutions B.V.
Address	Beethovenstraat 503 1083 HK Amsterdam Netherlands
Test Specification	47 CFR Part 22H 47 CFR Part 24E ISED RSS-132, Issue 3: 2013-01 ISED RSS-133, Issue 6+A1: 2018-01
Non-Standard Test Method	None
Equipment under Test (EUT):	
Product Description	Telematic Device with GSM+LTE+GNSS+OBD connector
Model(s)	L0245
Additional Model(s)	None
Brand Name(s)	webfleet Link 245
Hardware Version(s)	15/2021
Software Version(s)	3.11
FCC ID	2AGPAL0245
IC	20911-L0245
Test Result	PASSED

Possible test case verdicts:		
Required by standard but not tested	N/T	
Not required by standard	N/R	
Not applicable to EUT	N/A	
Test object does meet the requirement	P(PASS)	
Test object does not meet the requirement	F(FAIL)	
Testing:		
Test Lab Temperature	20 °C – 23 °C	
Test Lab Humidity	32 % – 38 %	
Date of receipt of test item	2022-02-15	
Report:		
Compiled by	Burkhard Pudell	
Tested by (+ signature) (Responsible for Test)	Burkhard Pudell	
Approved by (+ signature) (Deputy Head of Lab)	Toralf Jahn	
Date of Issue	2022-03-22	
Total number of pages	64	
General Remarks:		
<p>The test results presented in this report relate only to the object tested.</p> <p>The results contained in this report reflect the results for this particular model and serial number. It is the responsibility of the manufacturer to ensure that all production models meet the intent of the requirements detailed within this report.</p> <p>This report shall not be reproduced, except in full, without the written approval of the Issuing testing laboratory.</p>		
Additional Comments:		

VERSION HISTORY

Version History			
Version	Issue Date	Remarks	Revised By
01	2022-03-22	Initial Release	

ABBREVIATIONS AND ACRONYMS

Acronyms	
Acronym	Description
EUT	Equipment Under Test
FCC	Federal Communications Commission
ISED	Innovation, Science and Economic Development Canada
RBW	Resolution bandwidth
RMS	Root mean square
VBW	Video bandwidth
V _{NOM}	Nominal supply voltage

REPORT INDEX

1	Equipment (Test Item) Under Test.....	6
1.1	Photos – Equipment External.....	7
1.2	Photos – Equipment Internal.....	11
1.3	Support Equipment.....	14
1.4	Test Modes.....	15
1.5	Sample emission level calculation.....	16
2	Result Summary.....	17
3	Test Conditions and Results.....	18
3.1	Test Conditions and Results - Radiated power.....	18
3.2	Test Conditions and Results - Transmitter radiated emissions.....	20
3.3	Test Conditions and Results - Receiver radiated emissions.....	28
3.4	Test Conditions and Results - AC powerline conducted emissions.....	34
ANNEX A	Transmitter radiated emissions.....	39
ANNEX B	Receiver radiated emissions.....	54

1 Equipment (Test Item) Under Test

Description	Telematic Device with GSM+LTE+GNSS+OBD connector	
Model	L0245	
Additional Model(s)	None	
Brand Name(s)	webfleet Link 245	
Serial Number(s)	WY4481I00006 (SID: 38032)	
Hardware Version(s)	15/2021	
Software Version(s)	3.11	
PMN	LINK 245	
HVIN	L0245	
FVIN	3.11	
HMN	N/A	
IC	20911-L0245	
FCC ID	2AGPAL0245	
Equipment type	End Product	
Radio type	Transceiver	
Radio technologies	GSM	
GSM frequency bands	GSM 850 : UL = 824 - 849 MHz DL = 869 – 894 MHz GSM 1900 : UL = 1850 – 1910 MHz DL = 1930 – 1990 MHz	
GSM Modulations	GMSK, 8-PSK	
Number of modules	1	
Radio Module	Type	2G/4G module
	Model	EXS82
	Manufacturer	Gemalto (Thales)
	HW Version	A110
	SW Version	01.001
	FCC-ID	QIPEXS82-W
	IC	7830A-EXS82W
Antenna	Type	integrated
	Model	PCS.47.A
	Manufacturer	Taoglas
	Gain	-3.2...-4.2 dBi
Supply Voltage	V _{NOM}	12 VDC
AC/DC-Adaptor	Model	none
	Vendor	none
	Input	none
	Output	none
Manufacturer	Bridgestone Mobility Solutions B.V. Beethovenstraat 503 1083 HK Amsterdam Netherlands	

1.1 Photos – Equipment External

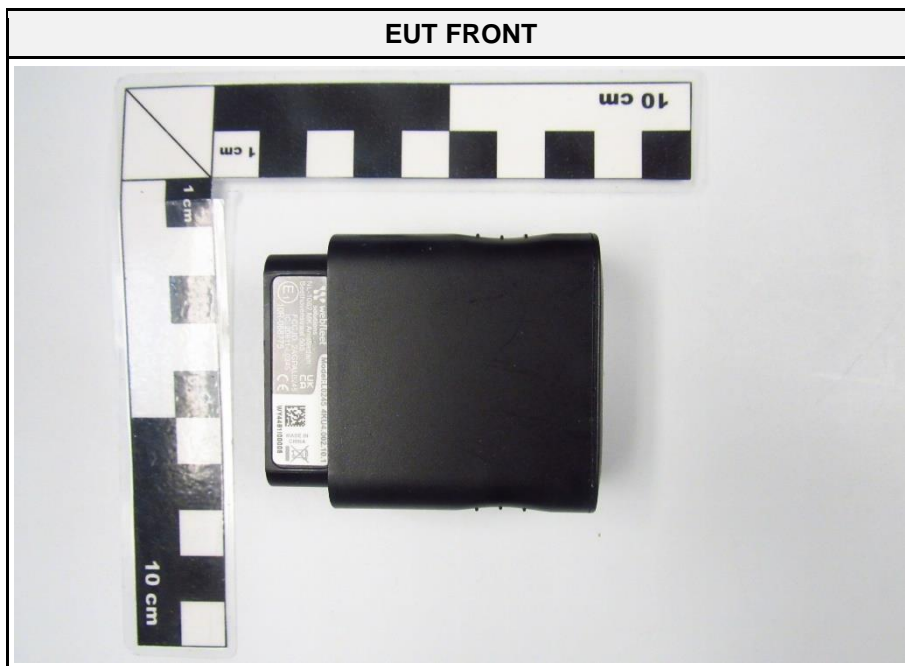
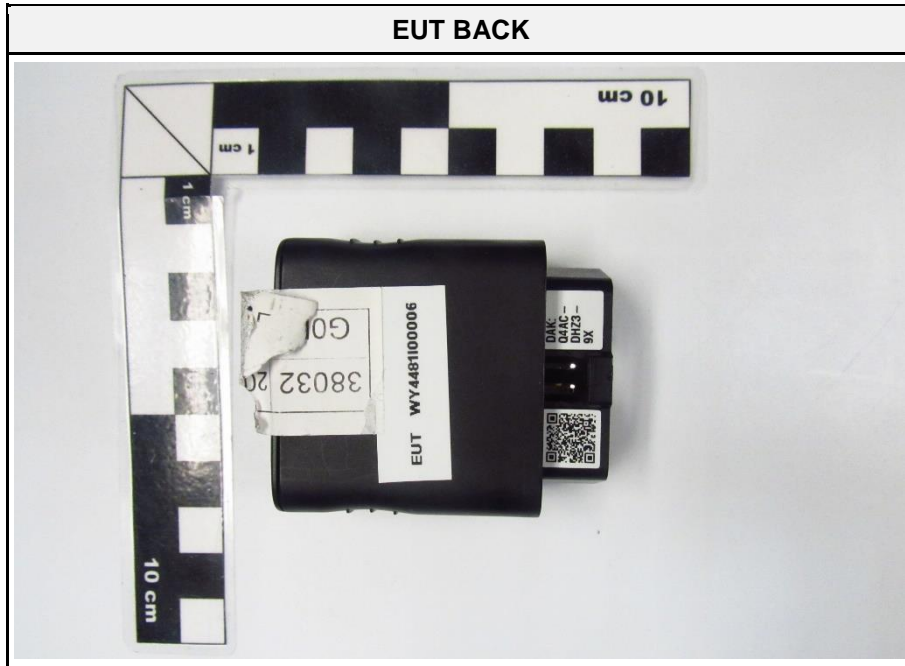

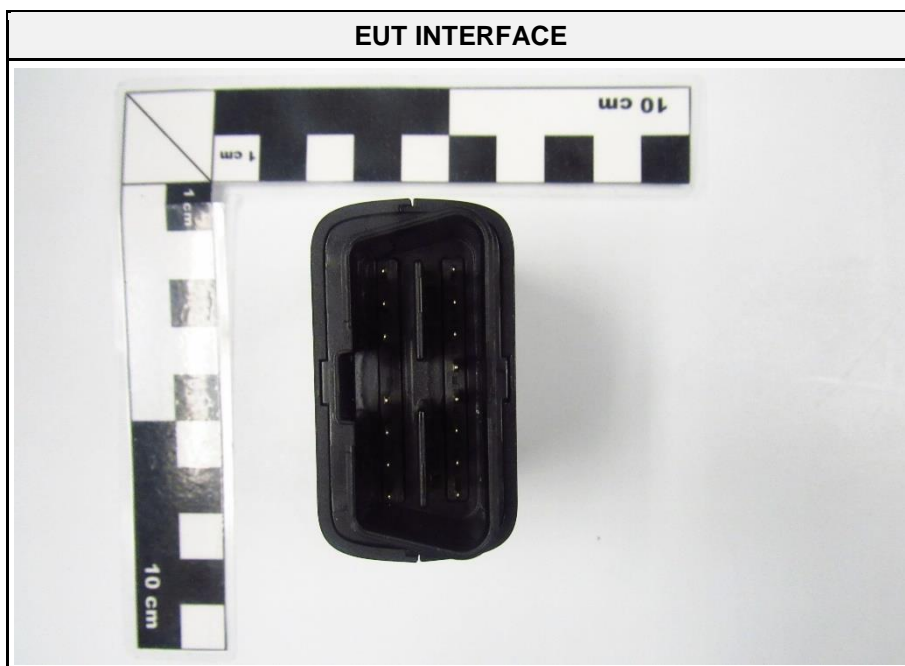
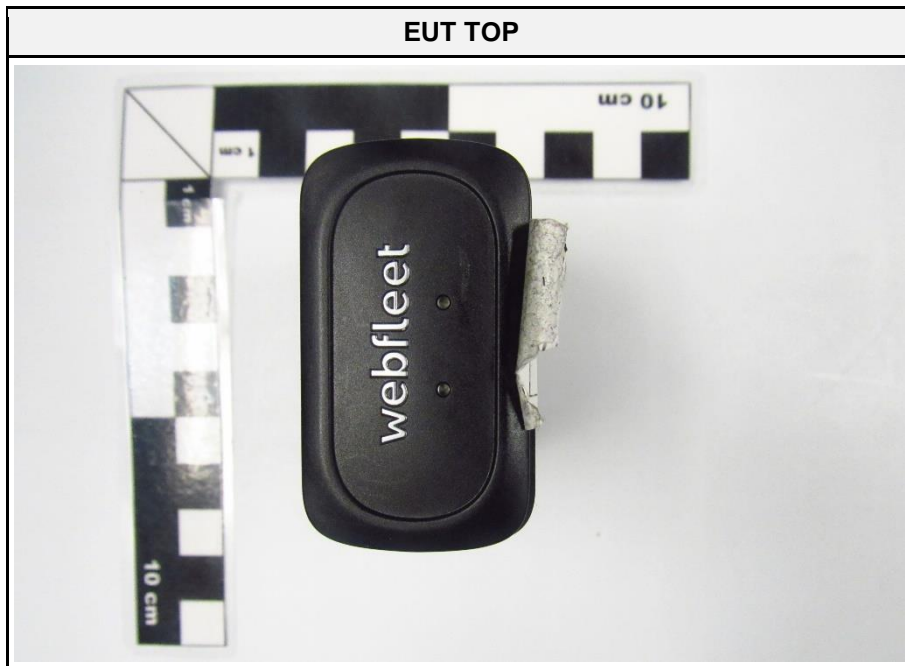



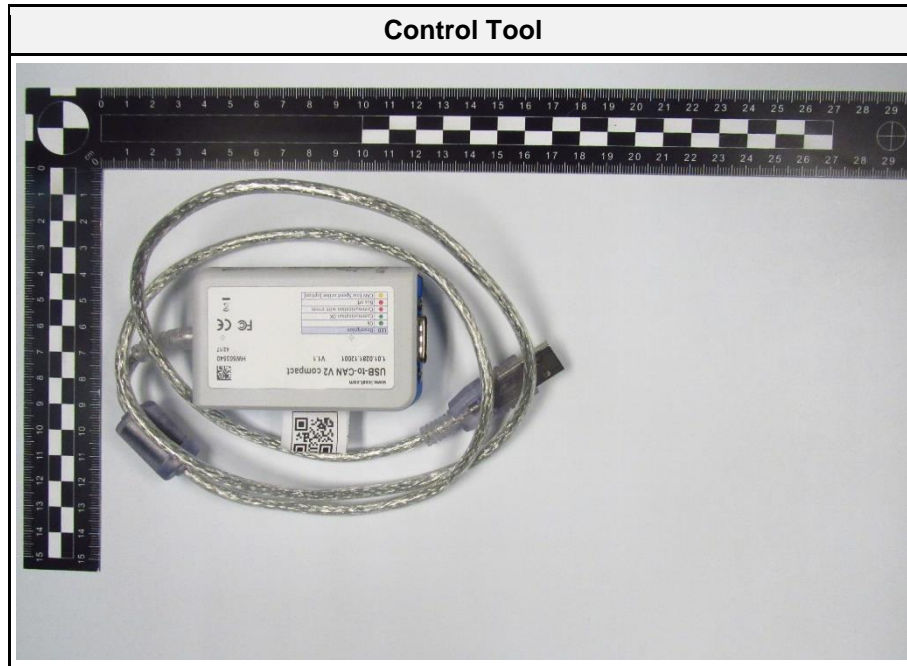

1.2 Photos – Equipment Internal

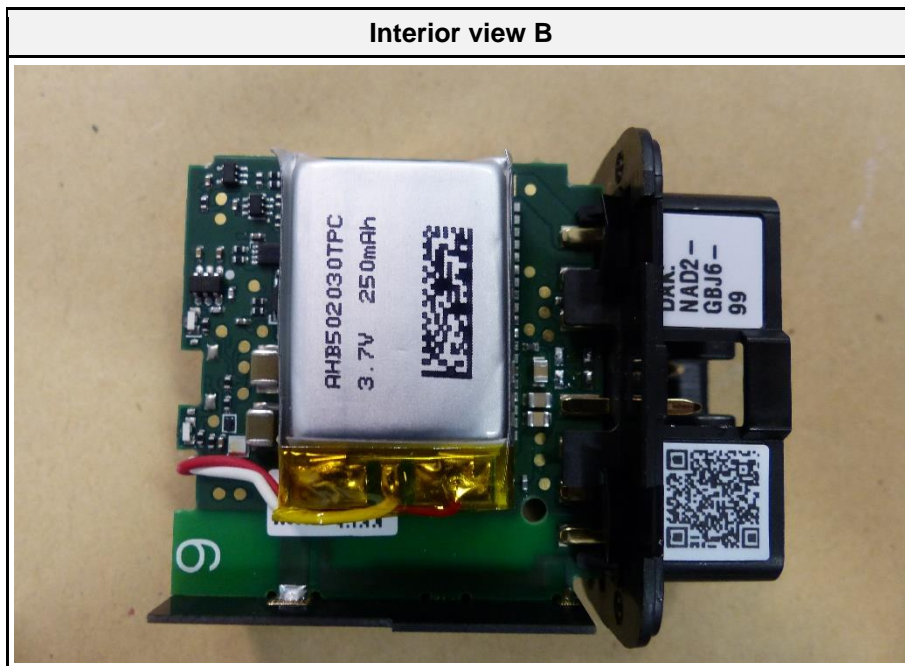
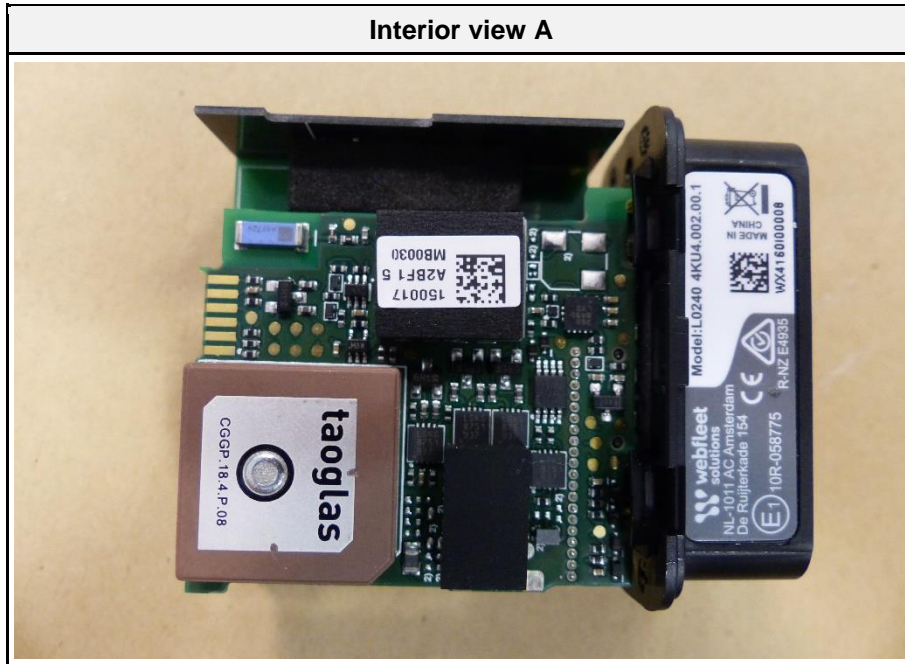

Interior view C

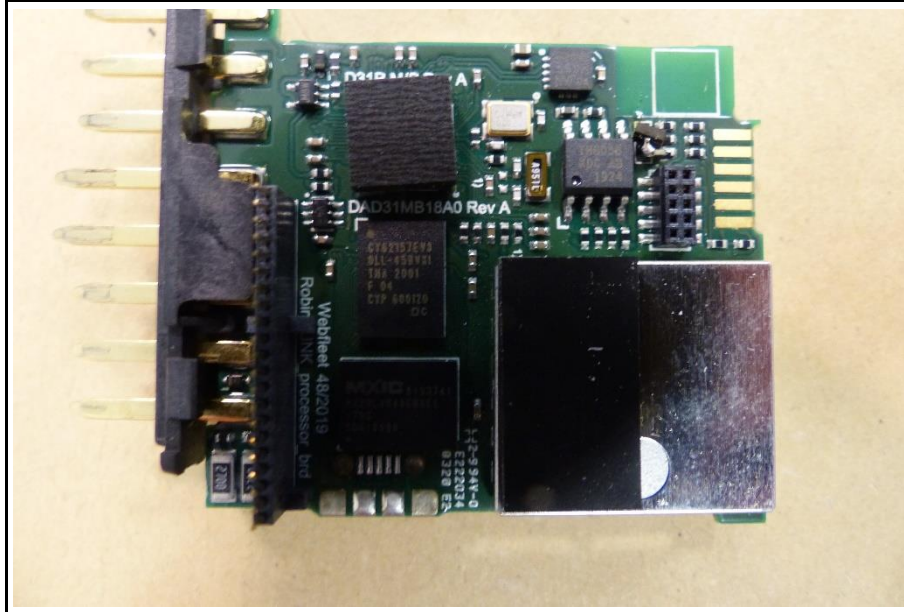

Interior view D

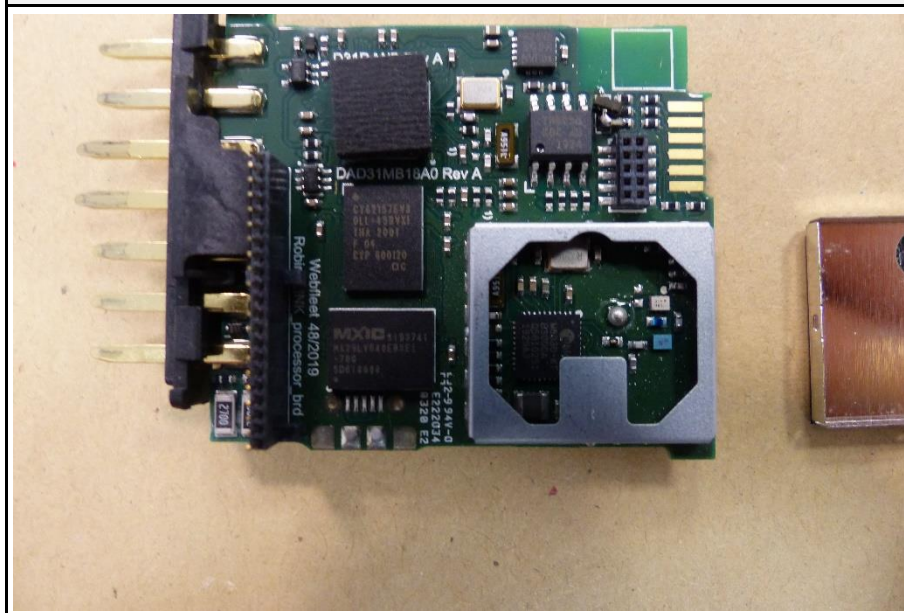

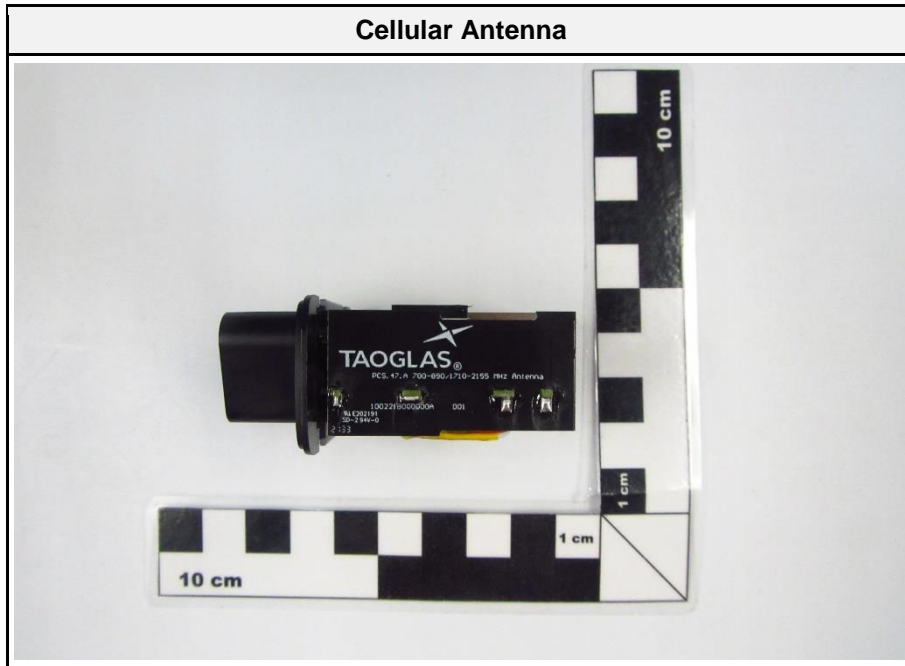

1.3 Support Equipment

Product Type	Device	Manufacturer	Model	Comment
SIM	Communication Tester	R&S	CMW500	Base Station Simulator
SFT	Remote Control	Webfleet Solutions Development Germany GmbH	DeviceCommunicationTool v0.9.0.99	Control unit
AE	USB to CAN bridge	IXXAT	USB to CAN V2	Control unit
Description:				
AE	Auxiliary Equipment			
SIM	Simulator			
CBL	Connecting Cable			
SFT	Software			
Comment:				

1.4 Test Modes

Mode	Description
GSM850 / GMSK	Channel = 189 (836.4 MHz) Mode = Transmit Power = Maximum Modulation = GMSK Number of time slots = 1 Duty cycle = 12.5 %
GSM850 / 8-PSK	None 1*)
GSM1900 / GMSK	Channel = 810 (1909.8 MHz) Mode = Transmit Power = Maximum Modulation = GMSK Number of time slots = 1 Duty cycle = 12.5 %
GSM1900 / 8-PSK	None 1*)
GSM850 / IDLE	Channel = 189 (836.4 MHz) Mode = Receive Modulation = GMSK
GSM1900 / IDLE	Channel = 810 (1909.8 MHz) Mode = Receive Modulation = GMSK
1*) 191019004RFM-1 issued by Union Trust Quality and Technology (Shenzhen, China) Co., Ltd. on 2019-12-21. Testlab documented only the worst case	

1.5 Sample emission level calculation

The following is a description of terms and a sample calculation, as appears in the radiated emissions data table. The numbers used in the calculation are for example only. There is no direct correlation to the specific data taken for the product described in this document:

Reading:

This is the reading obtained on the spectrum analyzer in dBµV. Any external preamplifiers used are taken into account through internal analyzer settings.

A.F.:

This is the antenna factor for the receiving antenna. It is a conversion factor, which converts electric fields strengths to voltages, which can be measured directly on the spectrum analyzer. It is treated as a loss in dB. Cable losses have been included with the A.F. to simplify the calculations. The antenna factor is used in calculations as follows:

$$\text{Reading on Analyzer (dB}\mu\text{V)} + \text{A.F. (dB)} = \text{Net field strength (dB}\mu\text{V/m)}$$

Net:

This is the net field strength measurement (as shown above).

Limit:

This is the FCC Class B radiated emission limit (in units of dBµV/m). The FCC limits are given in units of µV/m. The following formula is used to convert the units of µV/m to dBµV/m:

$$\text{Limit (dB}\mu\text{V/m)} = 20 \cdot \log(\mu\text{V/m})$$

Margin:

This is the margin of compliance below the FCC limit. The units are given in dB. A negative margin indicates the emission was below the limit. A positive margin indicates that the emission exceeds the limit.

Example only:

Reading + AF	= Net Reading	:	Net reading	- FCC limit	= Margin
+21.5 dBµV	+ 26 dB = 47.5 dBµV/m	:	47.5 dBµV/m	- 57.0 dBµV/m	= -9.5 dB

2 Result Summary

Test Summary)				
Product Standard Reference	Requirement	Reference Method	Result	Remarks
47 CFR §22.913 47 CFR §24.232 ISED RSS-132 §5.4 ISED RSS-133 §6.4	Radiated power	ANSI C63.26 KDB 971168	PASS	
47 CFR §22.917 47 CFR §24.238 ISED RSS-132 §5.5 ISED RSS-133 §6.5	Transmitter conducted emissions	ANSI C63.26 KDB 971168	N/T	Non removable integrated antenna
47 CFR §22.917 47 CFR §24.238 ISED RSS-132 §5.5 ISED RSS-133 §6.5	Transmitter radiated emissions	ANSI C63.26 KDB 971168	PASS	
ISED RSS-132 §3.1 ISED RSS-133 §3.1 ISED RSS-Gen §7	Receiver radiated emissions	ANSI C63.4	PASS	
FCC § 15.207; ISED RSS-247, Issue 2 (section 3.1)	AC powerline conducted emissions	ANSI C63.10 6.2	PASS	
Comment:				

Possible Test Case Verdicts	
PASS	Test object does meet the requirements
FAIL	Test object does not meet the requirements
N/T	Required by standard but not tested
N/R	Not required by standard for the test object

3 Test Conditions and Results

3.1 Test Conditions and Results - Radiated power

3.1.1 Information

Test Information	
Reference	47 CFR §22.913 47 CFR §24.232 ISED RSS-132 §5.4 ISED RSS-133 §6.4
Measurement Method	FCC KDB 971168 D01 Section 5 ANSI C63.26-2015 5.2
Measurement Uncertainty	N/A
Operator	Charline Graf
Date	2022-02-16

3.1.2 Limits

Limits - Portable equipment					
Band	Frequency range [MHz]	Power limit [dBm ERP]	Power limit [W ERP]	Power limit [dBm EIRP]	Power limit [W EIRP]
GSM850	824 - 849	38.45	7	40.6	11.5
GSM1900	1850 - 1910	30.85	1.22	33	2

3.1.3 Procedure

Test Procedure
<ol style="list-style-type: none"> The highest conducted output power for each radio technology, band, modulation and bandwidth is determined from module test reports: 191019004RFM-1 issued by Union Trust Quality and Technology (Shenzhen, China) Co., Ltd. on 2019-12-21. Testlab documented only the worst case The antenna gain for the corresponding transmission frequency is added to the conducted output power The calculated radiated power is compared to the transmitter output power limit

3.1.4 Results

Test Results - GSM850						
Mode	Power [dBm]	Antenna gain [dBi]	Radiated power [dBm EIRP]	Limit [dBm EIRP]	Margin [dB]	Result
GSM1900 / GMSK	32.82	-3.2	29.62	33	-7.30	PASS
GSM1900 / 8-PSK	191019004RFM-1 issued by Union Trust Quality and Technology (Shenzhen, China) Co., Ltd.on 2019-12-21. Testlab documented only the worst case					

Test Results - GSM1900						
Mode	Power [dBm]	Antenna gain [dBi]	Radiated power [dBm EIRP]	Limit [dBm EIRP]	Margin [dB]	Result
GSM1900 / GMSK	28.49	-3.2	25.29	33	-11.63	PASS
GSM1900 / 8-PSK	191019004RFM-1 issued by Union Trust Quality and Technology (Shenzhen, China) Co., Ltd.on 2019-12-21. Testlab documented only the worst case					

3.2 Test Conditions and Results - Transmitter radiated emissions

3.2.1 Information

Test Information	
Reference	47 CFR §22.917 47 CFR §24.238 ISED RSS-132 §5.5 ISED RSS-133 §6.5
Measurement Method	FCC KDB 971168 D01 Section 7 ANSI C63.26-2015 5.5
Measurement Uncertainty	± 5.95 dB
Operator	Burkhard Pudell
Date	2022-02-17

3.2.2 Limits

Limits FCC				
Band	Frequency range [MHz]	Bandwidth	Attenuation [dB]	Limit [dBm EIRP]
GSM850	-	100 kHz / 1 MHz	43+Log ₁₀ (P[W])	-13
GSM1900	-	1 MHz	43+Log ₁₀ (P[W])	-13

Limits ISED				
Band	Frequency range [MHz]	Bandwidth	Attenuation [dB]	Limit [dBm EIRP]
GSM850	-	100 kHz	43+Log ₁₀ (P[W])	-13
GSM1900	-	1 MHz	43+Log ₁₀ (P[W])	-13

3.2.3 Setup

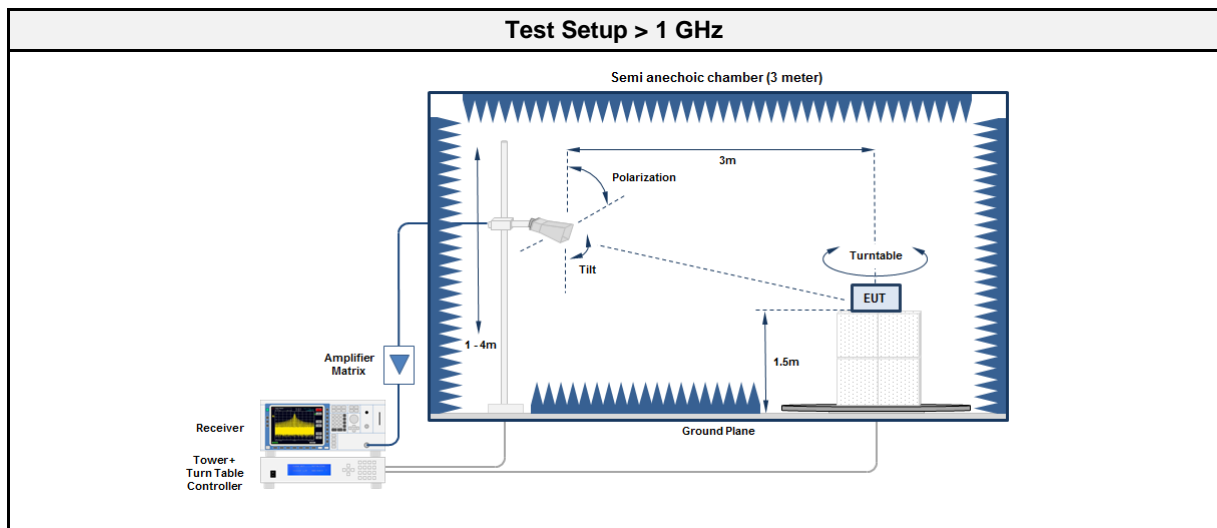
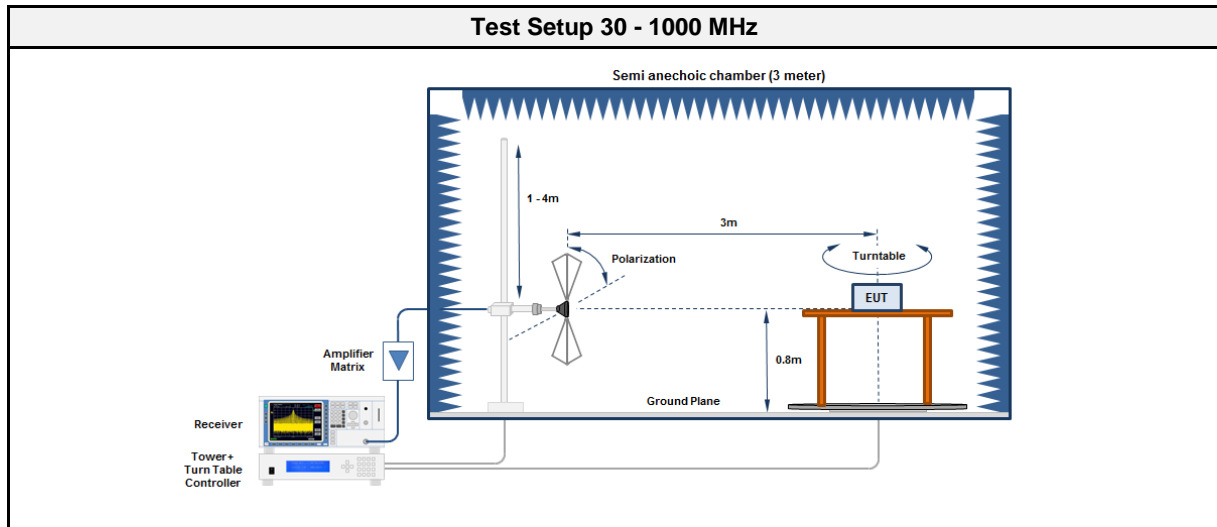

3.2.4 Equipment

Test Equipment 30 - 1000 MHz					
Description	Manufacturer	Model	Identifier	Cal. Date	Cal. Due
Anechoic Chamber	Frankonia	AC1	EF00062	2021-02	2024-02
Measurement Receiver	Agilent	N9038A-526/WXP	EF01070	2021-07	2022-07
Antenna	R&S	HK 116	EF00030	2021-05	2024-05
Antenna	R&S	HL 223	EF00187	2019-05	2022-05

Test Equipment > 1 GHz					
Description	Manufacturer	Model	Identifier	Cal. Date	Cal. Due
Anechoic Chamber	Frankonia	AC 2	EF01616	2021-09	2022-09
Spectrum Analyzer	R&S	FSU43	EF01631	2021-07	2022-07
Horn Antenna	Schwarzbeck	BBHA 9120B	EF01678	2021-03	2022-03
Antenna	Schwarzbeck	HWRD 650	EF01679	2021-03	2022-03
Antenna	Amplifier Research	AT4560	EF00302	2021-06	2023-06

Test Equipment > 1 GHz used for final measurements					
Description	Manufacturer	Model	Identifier	Cal. Date	Cal. Due
Anechoic Chamber	Frankonia	AC1	EF00062	2021-02	2024-02
Measurement Receiver	Agilent	N9038A-526/WXP	EF01070	2021-07	2022-07
Antenna	Schwarzbeck	BBHA 9120D	EF00018	2019-10	2022-10

3.2.5 Procedure

Test Procedure 30 - 1000 MHz
<ol style="list-style-type: none"> EUT is placed on a non conducting support at the center of a turn table 0.8 m above the ground EUT set to test mode The receiver is set to peak detection with max hold The EUT is rotated through 360° and the height of the antenna is varied from 1 m to 4 m All significant emissions are measured again using the corresponding final detector

Test Procedure > 1 GHz
<ol style="list-style-type: none"> EUT is placed on a non conducting support at the center of a turn table 1.5 m above the ground EUT set to test mode The receiver is set to peak detection with max hold The EUT is rotated through 360° and the height of the antenna is varied from 1 m to 4 m All significant emissions are measured again using the corresponding final detector

3.2.6 Results

Test Results - GSM850						
Mode	Frequency [MHz]	Level [dBm]	Polarization	Limit [dBm]	Margin [dB]	Result
GSM850 / GMSK	No significant emission detected.					

Test Results - GSM1900						
Mode	Frequency [MHz]	Level [dBm]	Polarization	Limit [dBm]	Margin [dB]	Result
GSM1900 / GMSK	33.978	-57.90	ver	-13.00	-44.89	PASS
GSM1900 / GMSK	145.375	-60.00	ver	-13.00	-46.95	PASS
GSM1900 / GMSK	237.58	-46.40	ver	-13.00	-33.36	PASS
GSM1900 / GMSK	238.16	-50.30	ver	-13.00	-37.27	PASS

3.2.7 Setup Photos

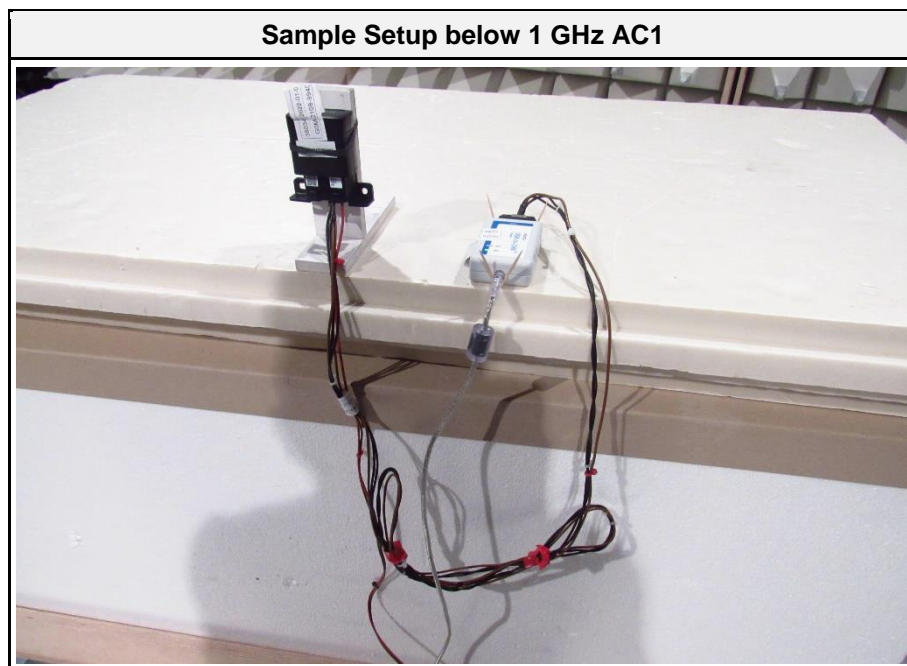
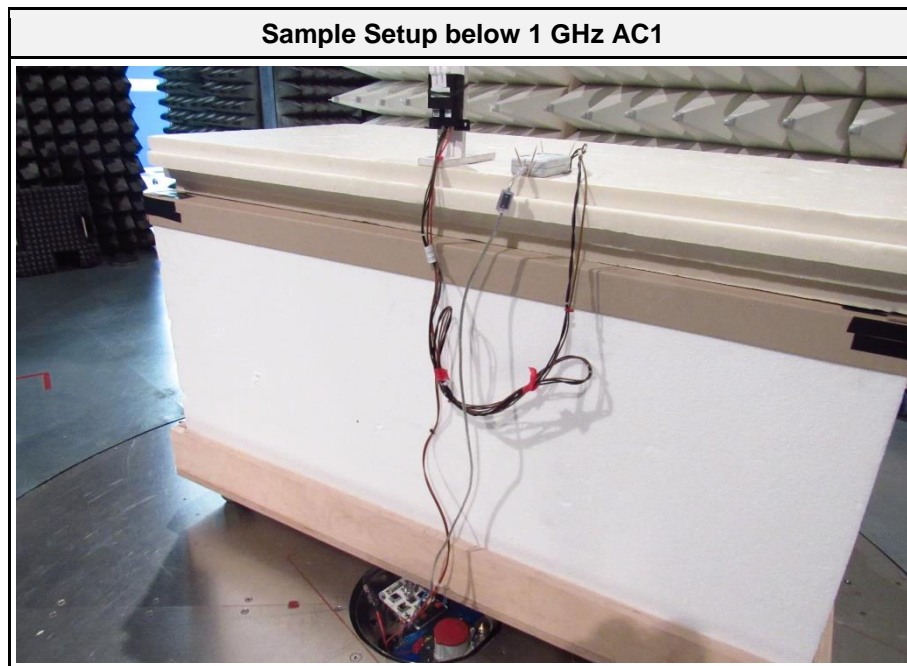

Tx below 1 GHz AC1

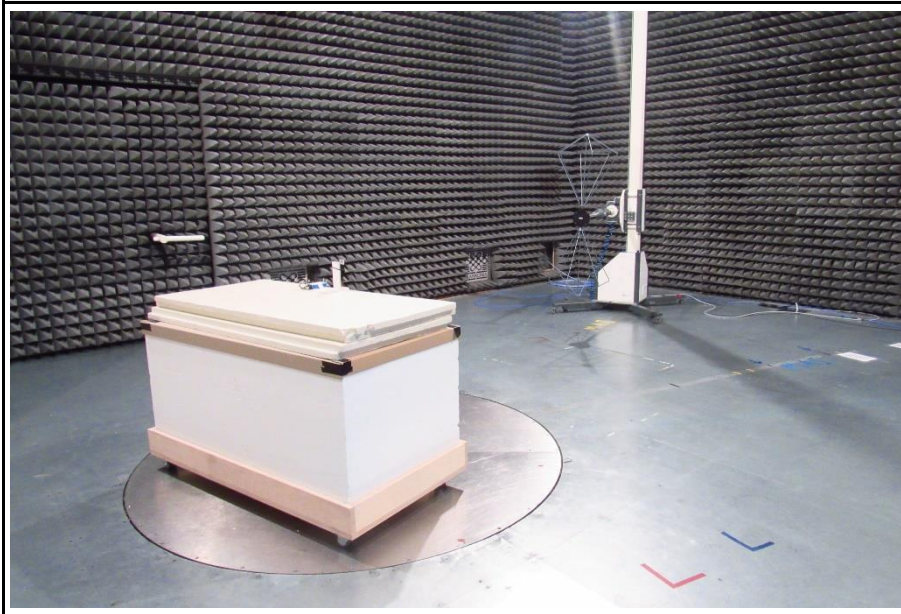

Tx below 1 GHz AC1



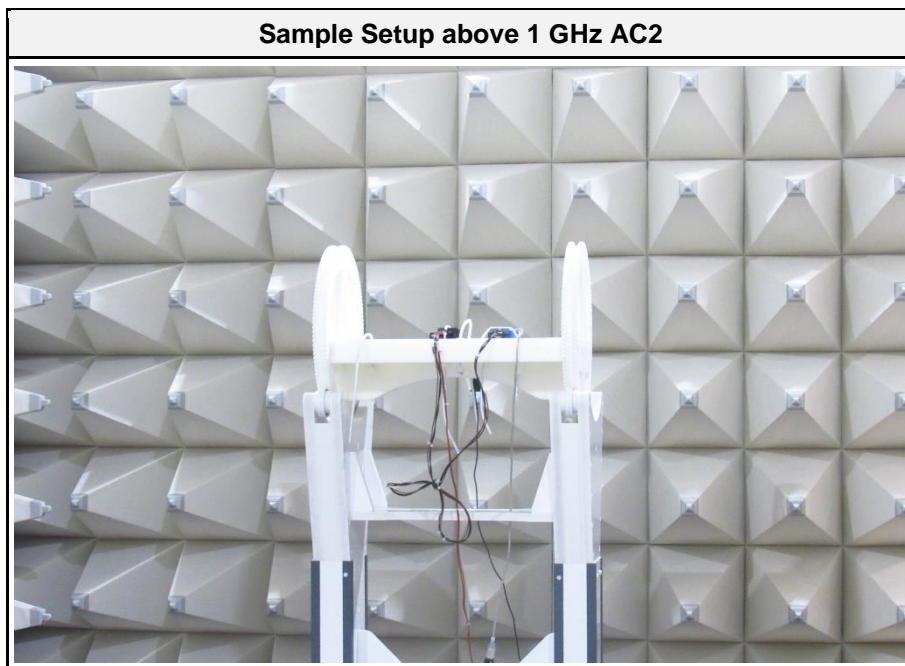
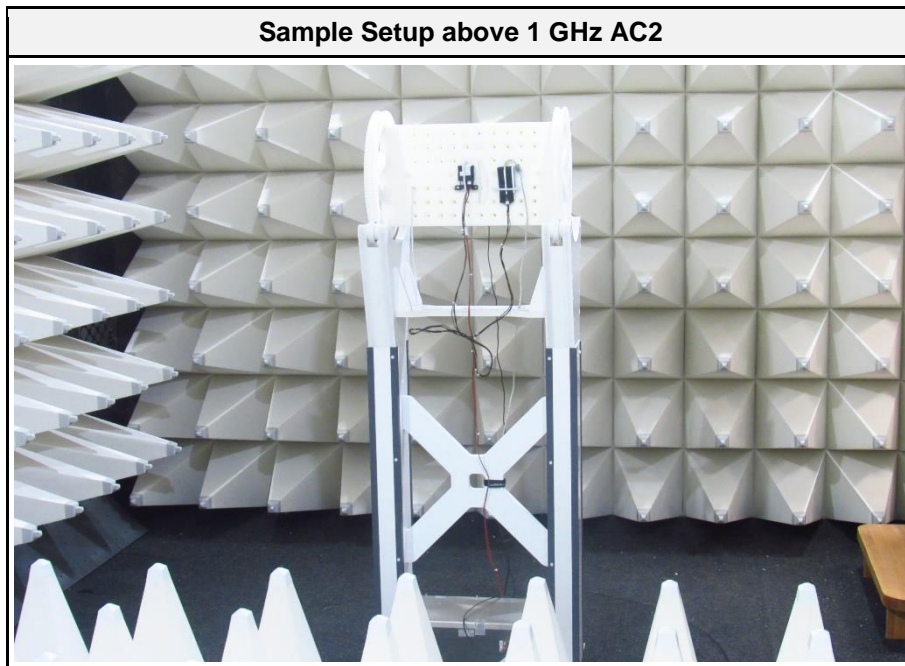

Sample Setup above 1 GHz AC2

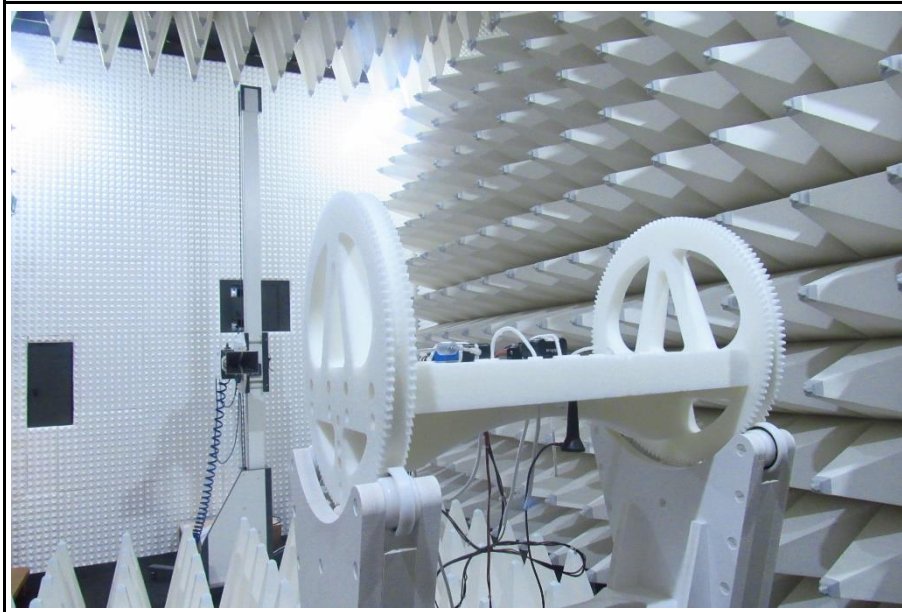

Tx above 1 GHz AC2

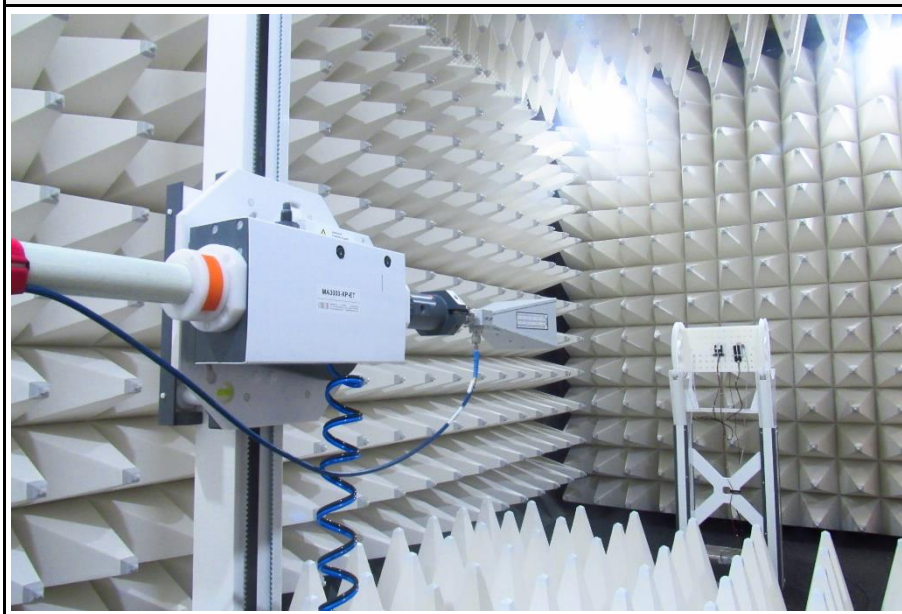

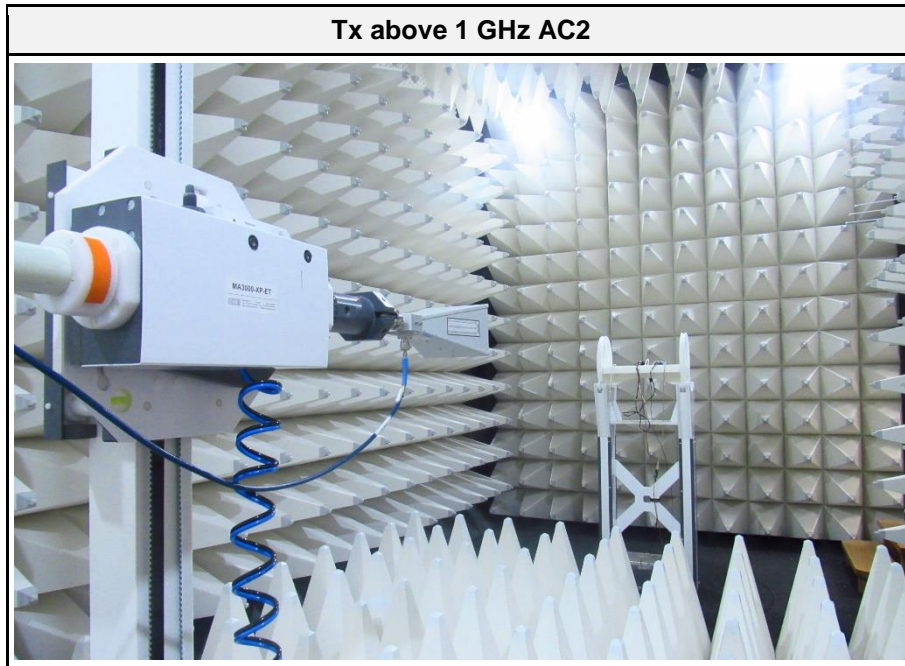

3.3 Test Conditions and Results - Receiver radiated emissions

3.3.1 Information

Test Information	
Reference	ISED RSS-132 §3.1 ISED RSS-133 §3.1 ISED RSS-Gen §7.4
Measurement Method	ANSI C63.4-2014 8.1-8.3
Measurement Uncertainty	± 5.95 dB
Operator	Burkhard Pudell
Date	2022-02-17

3.3.2 Limits

Limits			
Frequency range [MHz]	Bandwidth	Detector	Limit [dBμV/m @ 3 m]
30 - 88	100 kHz	Quasi-peak	40
88 - 216	100 kHz	Quasi-peak	43.5
216 - 960	100 kHz	Quasi-peak	46
960 - 1000	100 kHz	Quasi-peak	54
> 1000	1 MHz	Average	54

3.3.3 Setup

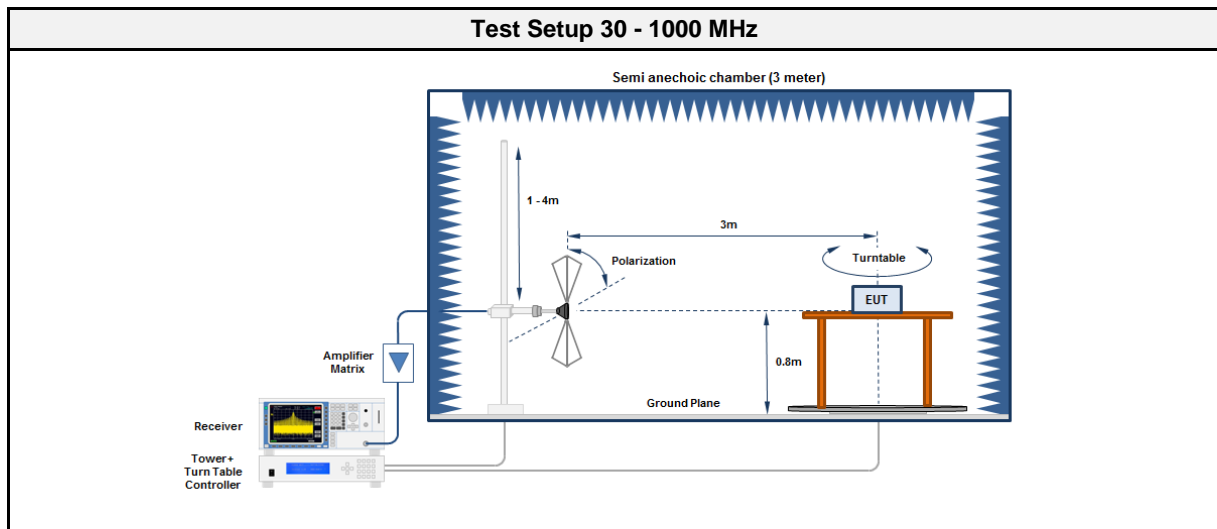

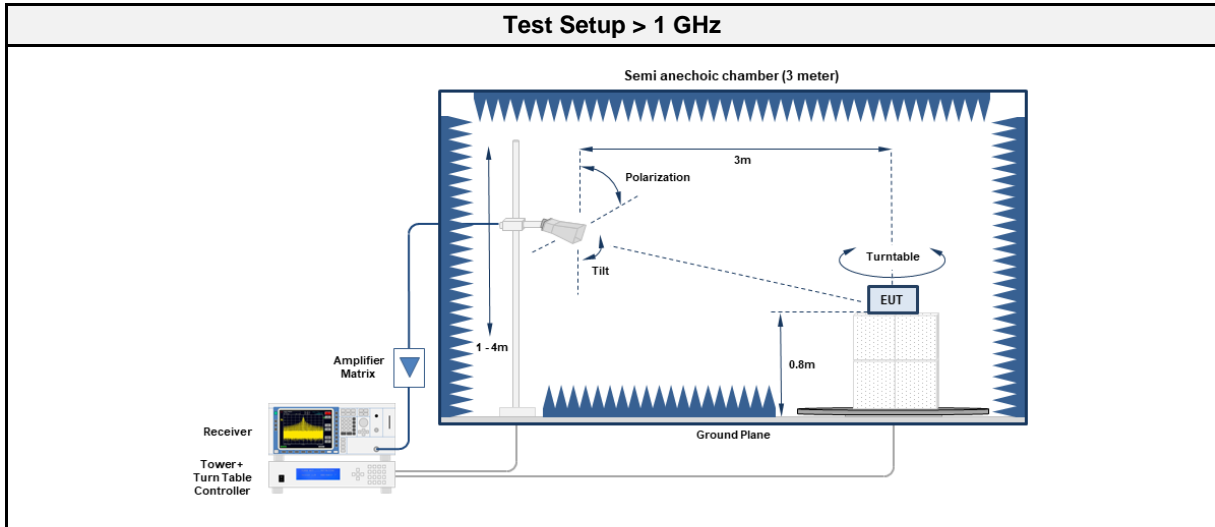

3.3.4 Equipment

Test Equipment 30 - 1000 MHz					
Description	Manufacturer	Model	Identifier	Cal. Date	Cal. Due
Anechoic Chamber	Frankonia	AC1	EF00062	2021-02	2024-02
Measurement Receiver	Agilent	N9038A-526/WXP	EF01070	2021-07	2022-07
Antenna	R&S	HK 116	EF00030	2021-05	2024-05
Antenna	R&S	HL 223	EF00212	2019-05	2022-05

Test Equipment > 1 GHz					
Description	Manufacturer	Model	Identifier	Cal. Date	Cal. Due
Anechoic Chamber	Frankonia	AC1	EF00062	2021-02	2024-02
Measurement Receiver	Agilent	N9038A-526/WXP	EF01070	2021-07	2022-07
Antenna	Schwarzbeck	BBHA 9120D	EF00018	2019-10	2022-10

3.3.5 Procedure

Test Procedure 30 - 1000 MHz
<ol style="list-style-type: none"> EUT is placed on a non conducting support at the center of a turn table 0.8 m above the ground EUT set to test mode The receiver is set to peak detection with max hold The EUT is rotated through 360° and the height of the antenna is varied from 1 m to 4 m All significant emissions are measured again using the corresponding final detector

Test Procedure > 1 GHz
<ol style="list-style-type: none"> EUT is placed on a non conducting support at the center of a turn table 1.5 m above the ground EUT set to test mode The receiver is set to peak detection with max hold The EUT is rotated through 360° and the height of the antenna is varied from 1 m to 4 m All significant emissions are measured again using the corresponding final detector

3.3.6 Results

Test Results - GSM850							
Mode	Frequency [MHz]	Level [dB μ V/m]	Detector	Polarization	Limit [dB μ V/m]	Margin [dB]	Result
GSM850 / IDLE	33.7527	18.60	qpk	ver	40.00	-21.42	PASS
GSM850 / IDLE	33.978	24.40	pk	ver	40.00	-15.57	PASS
GSM850 / IDLE	59.0572	22.40	pk	ver	40.00	-17.63	PASS
GSM850 / IDLE	145.2175	24.30	pk	ver	43.50	-19.25	PASS
GSM850 / IDLE	161.6948	25.00	pk	ver	43.50	-18.47	PASS
GSM850 / IDLE	236.6359	27.50	qpk	ver	46.00	-18.53	PASS
GSM850 / IDLE	237.0047	26.00	qpk	ver	46.00	-20.01	PASS
GSM850 / IDLE	443.5726	29.80	qpk	ver	46.00	-16.20	PASS
GSM850 / IDLE	443.58	29.70	qpk	ver	46.00	-16.29	PASS
GSM850 / IDLE	467.56	29.30	qpk	ver	46.00	-16.66	PASS
GSM850 / IDLE	475.8692	28.80	qpk	ver	46.00	-17.23	PASS

Test Results - GSM1900							
Mode	Frequency [MHz]	Level [dB μ V/m]	Detector	Polarization	Limit [dB μ V/m]	Margin [dB]	Result
GSM1900 / IDLE	32.244	23.20	pk	ver	40.00	-16.78	PASS
GSM1900 / IDLE	34.284	23.00	pk	ver	40.00	-16.97	PASS
GSM1900 / IDLE	60.056	22.40	pk	ver	40.00	-17.63	PASS
GSM1900 / IDLE	64.306	22.70	pk	ver	40.00	-17.28	PASS
GSM1900 / IDLE	145.0943	24.40	pk	ver	43.50	-19.10	PASS
GSM1900 / IDLE	145.2303	23.60	pk	ver	43.50	-19.87	PASS
GSM1900 / IDLE	153.2543	23.40	pk	ver	43.50	-20.11	PASS
GSM1900 / IDLE	161.6948	24.80	pk	ver	43.50	-18.75	PASS
GSM1900 / IDLE	234.5696	25.70	qpk	ver	46.00	-20.34	PASS
GSM1900 / IDLE	237.88	28.10	qpk	ver	46.00	-17.92	PASS
GSM1900 / IDLE	443.4821	30.70	qpk	ver	46.00	-15.26	PASS
GSM1900 / IDLE	467.68	30.00	qpk	ver	46.00	-15.97	PASS

3.3.7 Setup Photos

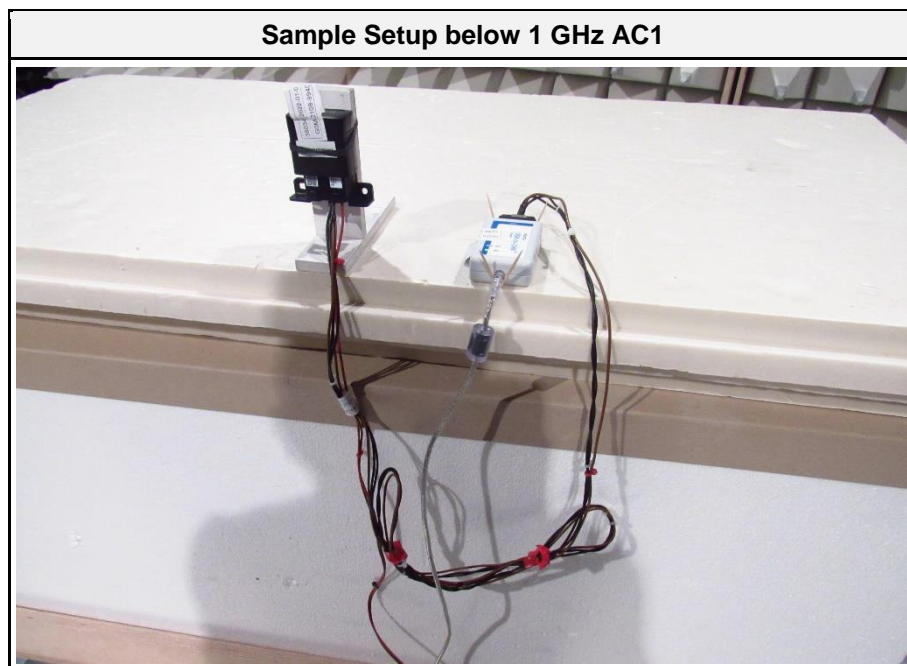
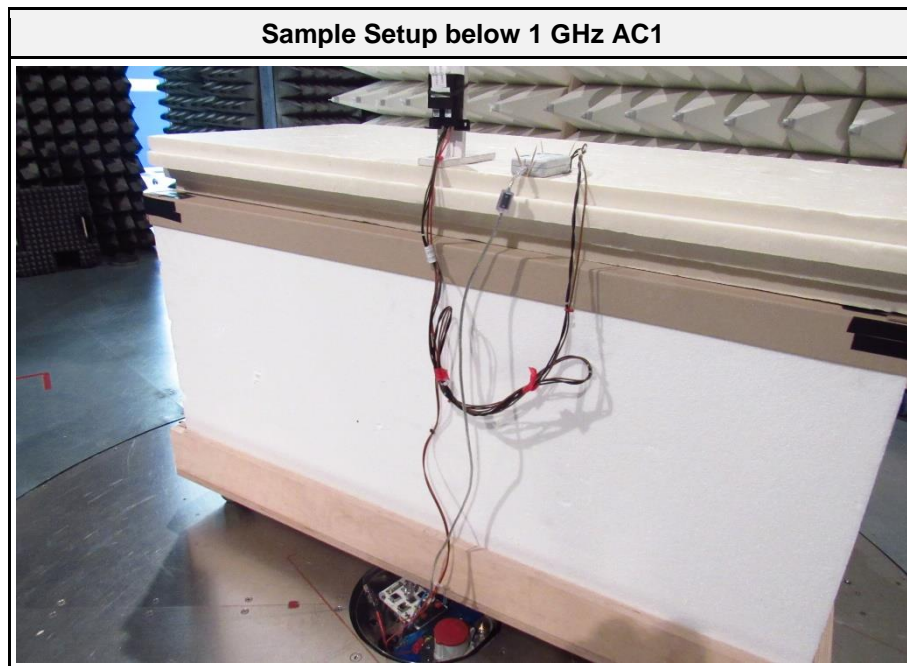

Rx below 1 GHz AC1

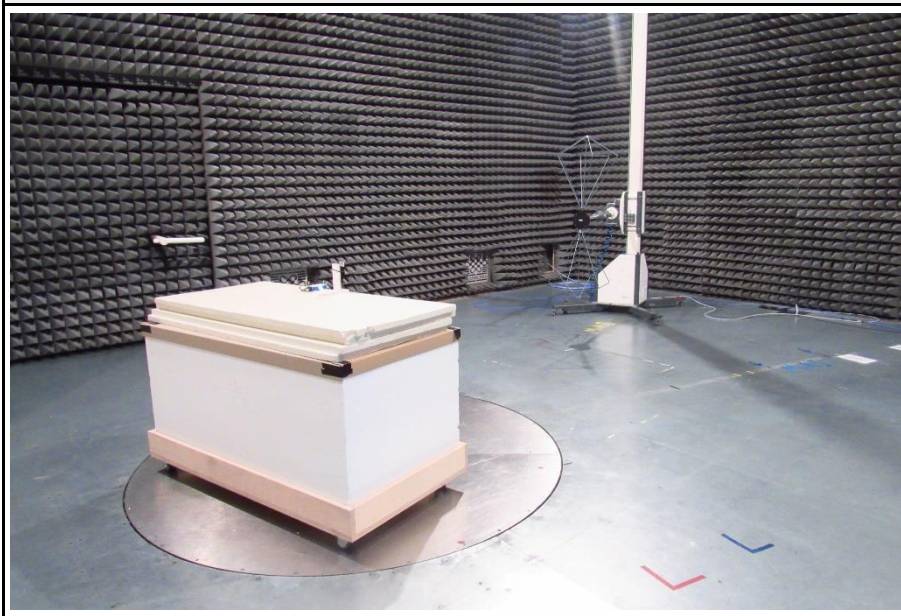

Rx below 1 GHz AC1



Rx above 1 GHz AC1

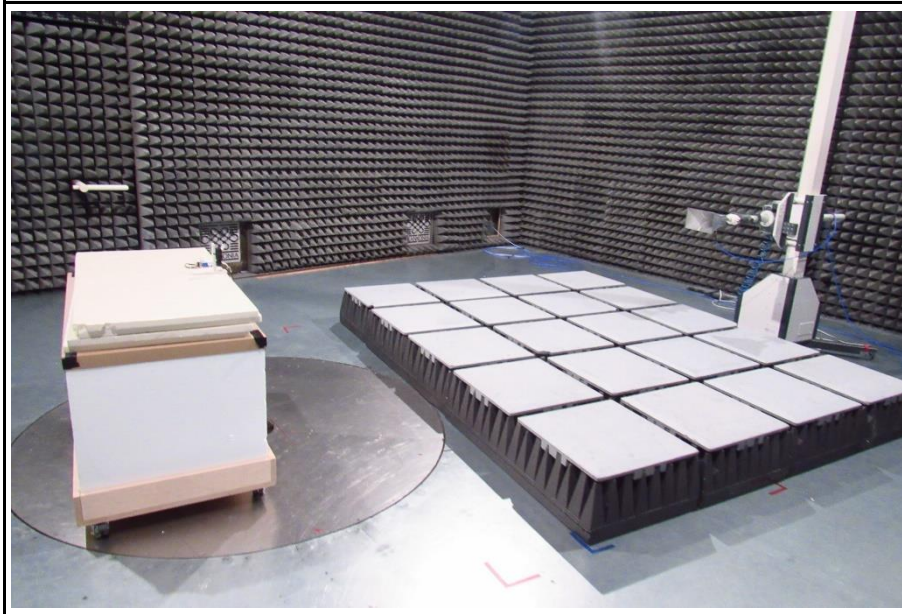

Rx above 1 GHz AC1



3.4 Test Conditions and Results - AC powerline conducted emissions

3.4.1 Information

Test Information	
Reference	FCC § 15.207; ISED RSS-247, Issue 2 (section 3.1)
Measurement Method	ANSI C63.10 6.2
Measurement Uncertainty	± 3.82 dB
Operator	Odai Qawasmeh
Date	2022-02-24

3.4.2 Limits

Limits		
Frequency [MHz]	Quasi-Peak [dBµV]	Average [dBµV]
0.15 - 0.5	66 - 56*	56 - 46*
0.5 - 5	56	46
5 - 30	60	50

* Limit decreases linearly with the logarithm of the frequency

3.4.3 Setup

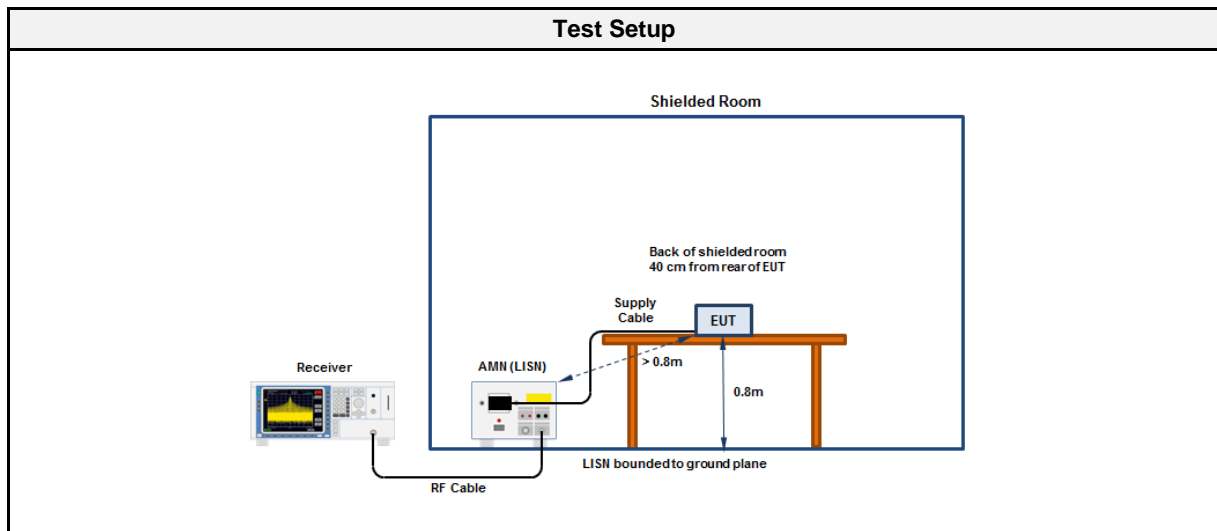

3.4.4 Equipment

Test Software			
Description	Manufacturer	Name	Version
EMC Software	DARE Instruments	RadiMation	2020.1.8

Test Equipment					
Description	Manufacturer	Model	Identifier	Cal. Date	Cal. Due
EMI Test Receiver	R&S	ESR7	EF00943	2021-08	2022-08
Pulse Limiter	R&S	ESH3-Z2	EF01222	2021-07	2022-07
LISN	Schwarzbeck	NSLK 8127 RC	EF01592	2021-07	2022-07

3.4.5 Setup Photos

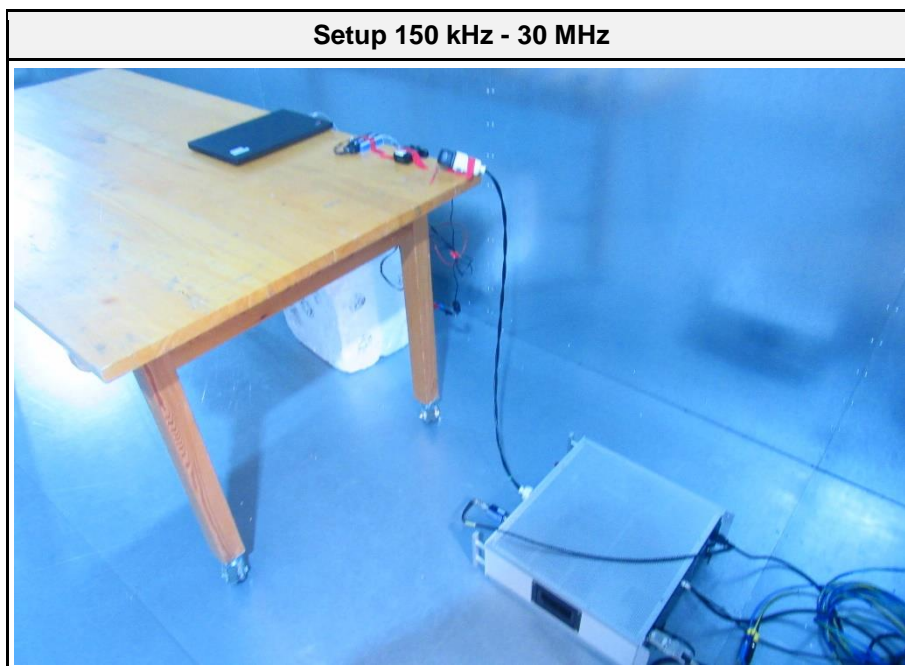
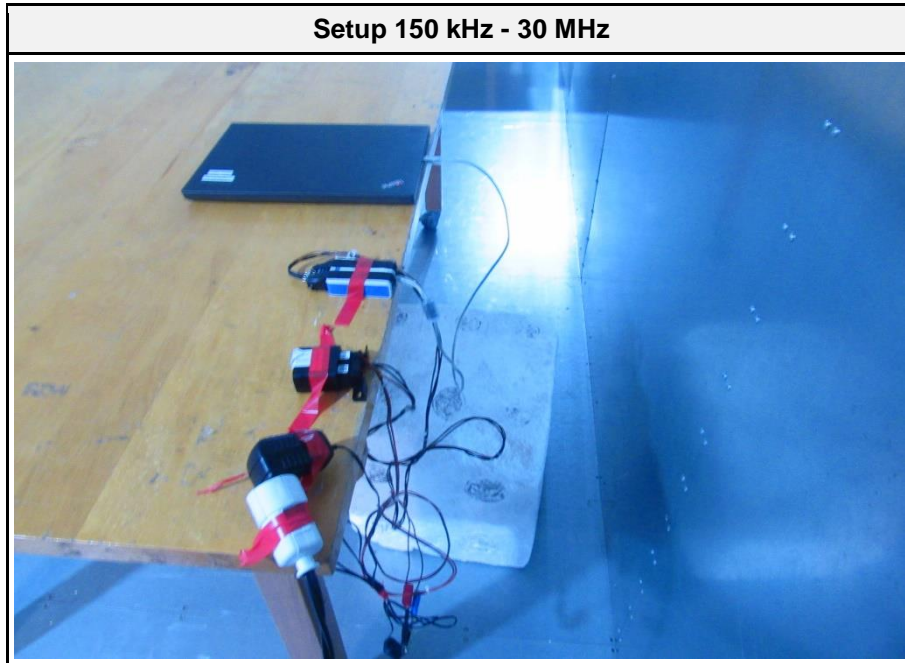

3.4.6 Results

Conducted emissions at the mains power port according to Part 15.247, FCC Part 22H, ISED RSS-247, Issue 2, ISED RSS-132, Issue 3

Project Number: G0M-2108-9942
 Applicant: Bridgestone Mobility Solutions B.V.
 Model Description: Telematic Device with GSM+LTE+GNSS+OBD connector
 Model: L0245
 Test Sample ID: 38032
 Test Site: Eurofins Product Service GmbH
 Operator: Mr. Qawasmeh
 Test Date: 2022-02-24
 Operating Conditions: ambient temperature: 24 °Celsius; power input: 12 VDC
 LISN: Schwarzbeck NSLK 8127 RC L
 Operational Mode & EUT Configuration: BT-BR DH5; 2480 MHz + GSM 850 CH 189 Tx+ GNSS on
 Applied to Port: Mains

Index 37

RadiMation

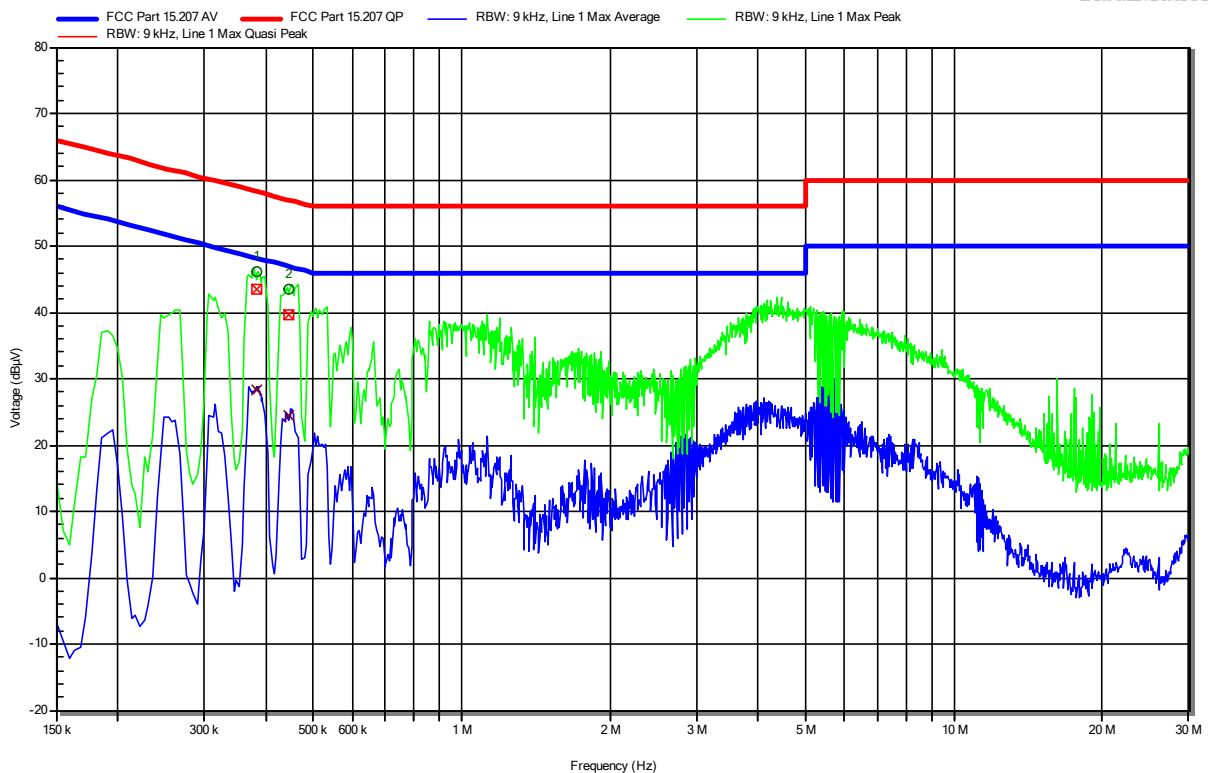

Peak Number	Frequency	Quasi-Peak	Quasi-Peak Limit	Quasi-Peak Difference	Quasi-Peak Status	LISN
1	384.9 kHz	43.38 dBµV	58.17 dBµV	-14.8 dB	Pass	Line 1
2	447 kHz	39.66 dBµV	56.93 dBµV	-17.27 dB	Pass	Line 1
Peak Number	Frequency	Average	Average Limit	Average Difference	Average Status	LISN
1	384.9 kHz	28.36 dBµV	48.17 dBµV	-19.82 dB	Pass	Line 1
2	447 kHz	24.35 dBµV	46.93 dBµV	-22.58 dB	Pass	Line 1

Conducted emissions at the mains power port according to Part 15.247, FCC Part 22H, ISED RSS-247, Issue 2, ISED RSS-132, Issue 3

Project Number: G0M-2108-9942
 Applicant: Bridgestone Mobility Solutions B.V.
 Model Description: Telematic Device with GSM+LTE+GNSS+OBD connector
 Model: L0245
 Test Sample ID: 38032
 Test Site: Eurofins Product Service GmbH
 Operator: Mr. Qawasmeh
 Test Date: 2022-02-24
 Operating Conditions: ambient temperature: 24 °Celsius; power input: 12 VDC
 LISN: Schwarzbeck NSLK 8127 RC N
 Operational Mode & EUT Configuration: BT-BR DH5; 2480 MHz + GSM 850 CH 189 Tx+ GNSS on
 Applied to Port: Mains

Index 38

RadiMation

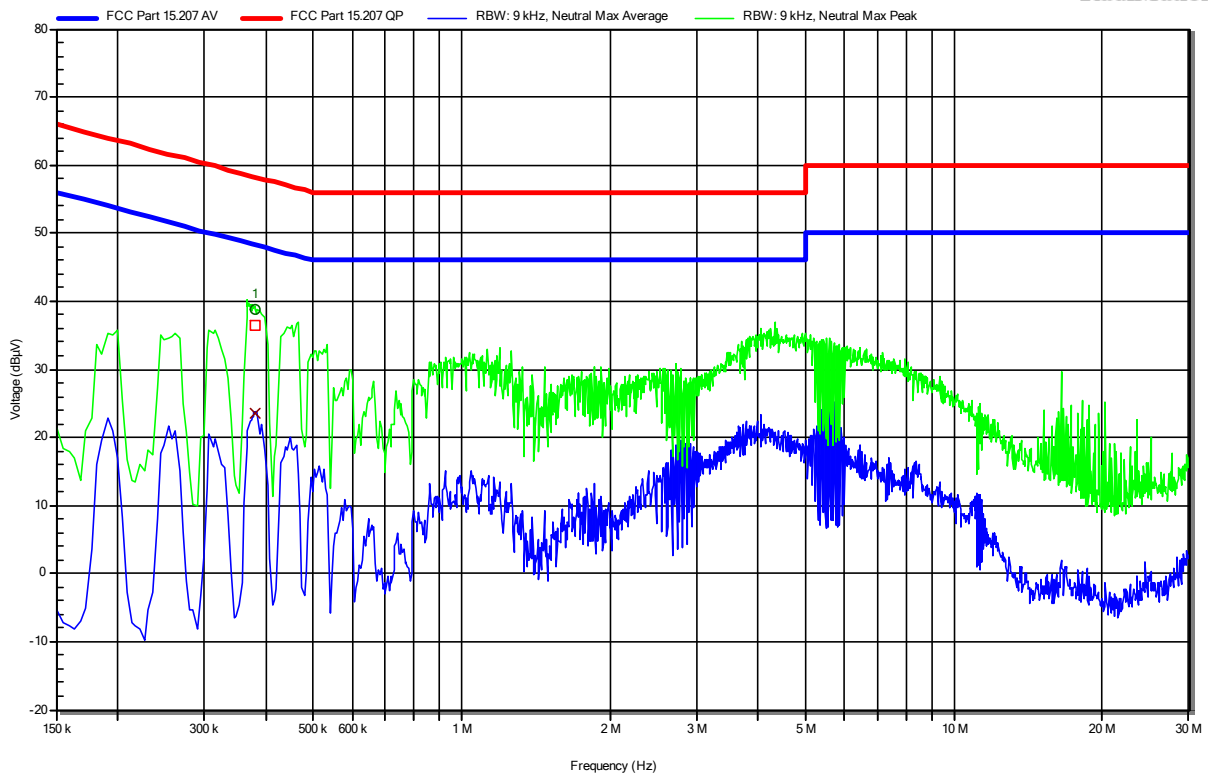

Peak Number	Frequency	Quasi-Peak	Quasi-Peak Limit	Quasi-Peak Difference	Quasi-Peak Status	LISN
1	379.5 kHz	36.5 dBµV	58.29 dBµV	-21.79 dB	Pass	Neutral
Peak Number	Frequency	Average	Average Limit	Average Difference	Average Status	LISN
1	379.5 kHz	23.55 dBµV	48.29 dBµV	-24.74 dB	Pass	Neutral

ANNEX A Transmitter radiated emissions

Radiated Spurious Emissions according to 47 CFR Part 22 Subpart H, RSS-132, Issue 3

Project Number: G0M-2108-9942
 Applicant: Bridgestone Mobility Solutions B.V.
 Model Description: Telematic Device with GSM+LTE+GNSS+OBD connector
 Model: L0245
 Test Sample ID: 38032 (SN: WY4481I00006)
 Test Site: Eurofins Product Service GmbH
 Operator: Mr. Degenhardt
 Measurement software: RadiMation, version 2020.1.8
 Test Conditions: Tnom: 23 °Celsius, Vnom: 12 VDC
 Antenna: Rohde & Schwarz HK 116
 Measurement distance: 3 m
 Mode: Tx; GPRS 850 Ch 189 GMSK 1xSlot Gamma 3
 Test Date: 2022-02-17
 Note: EUT horizontal

Index 8

RadiMation

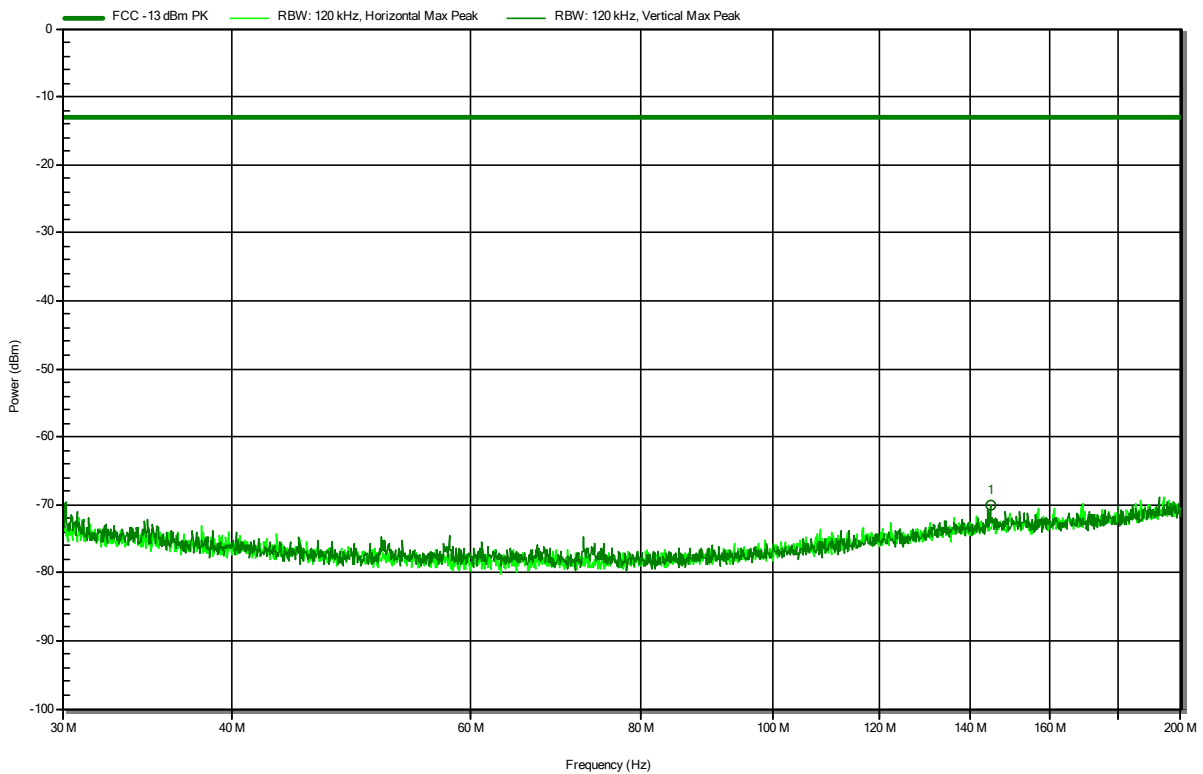

Radiated Spurious Emissions according to 47 CFR Part 22 Subpart H, RSS-132, Issue 3

Project Number: G0M-2108-9942
 Applicant: Bridgestone Mobility Solutions B.V.
 Model Description: Telematic Device with GSM+LTE+GNSS+OBD connector
 Model: L0245
 Test Sample ID: 38032 (SN: WY4481I00006)
 Test Site: Eurofins Product Service GmbH
 Operator: Mr. Degenhardt
 Measurement software: RadiMation, version 2020.1.8
 Test Conditions: Tnom: 23 °Celsius, Vnom: 12 VDC
 Antenna: Rohde & Schwarz HK 116
 Measurement distance: 3 m
 Mode: Tx; GPRS 850 Ch 189 GMSK 1xSlot Gamma 3
 Test Date: 2022-02-17
 Note: EUT vertical

Index 7

RadiMation

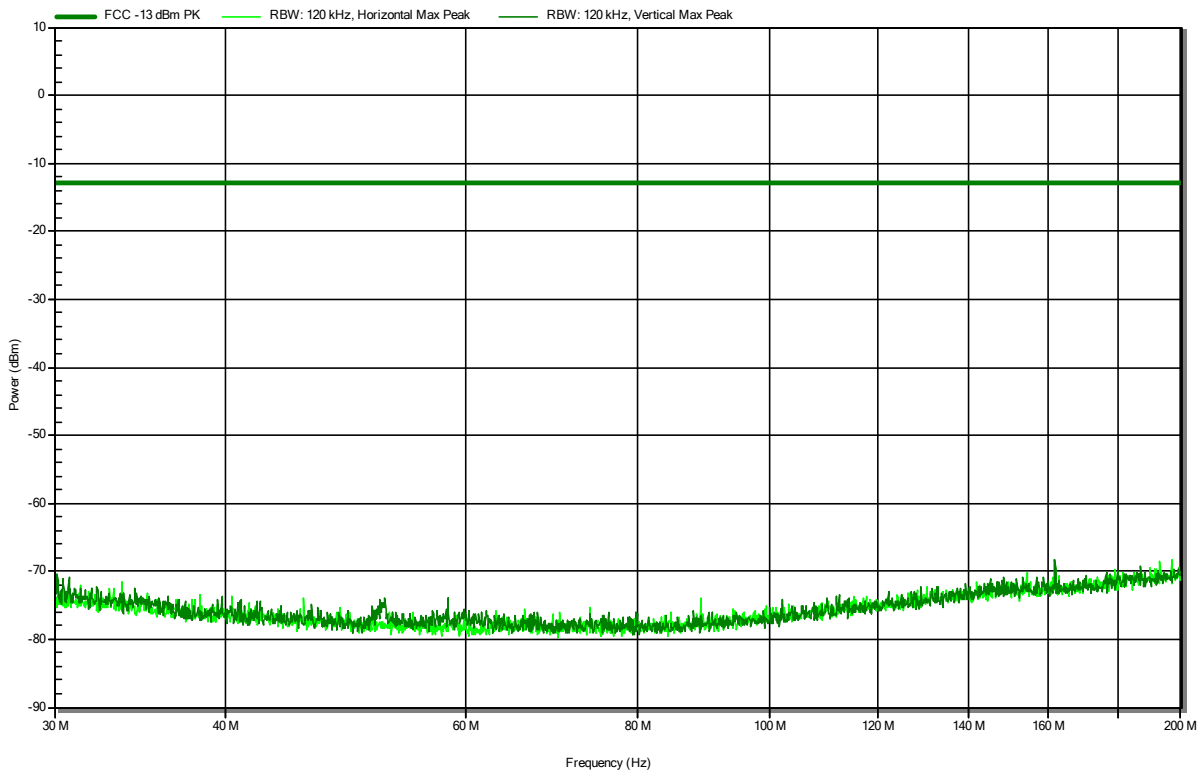

Radiated Spurious Emissions according to 47 CFR Part 22 Subpart H, RSS-132, Issue 3

Project Number: G0M-2108-9942
 Applicant: Bridgestone Mobility Solutions B.V.
 Model Description: Telematic Device with GSM+LTE+GNSS+OBD connector
 Model: L0245
 Test Sample ID: 38032 (SN: WY4481I00006)
 Test Site: Eurofins Product Service GmbH
 Operator: Mr. Degenhardt
 Measurement software: RadiMation, version 2020.1.8
 Test Conditions: Tnom: 23 °Celsius, Vnom: 12 VDC
 Antenna: Rohde & Schwarz HL 223
 Measurement distance: 3 m
 Mode: Tx; GPRS 850 Ch 189 GMSK 1xSlot Gamma 3
 Test Date: 2022-02-17
 Note: EUT horizontal

Index 9

RadiMation

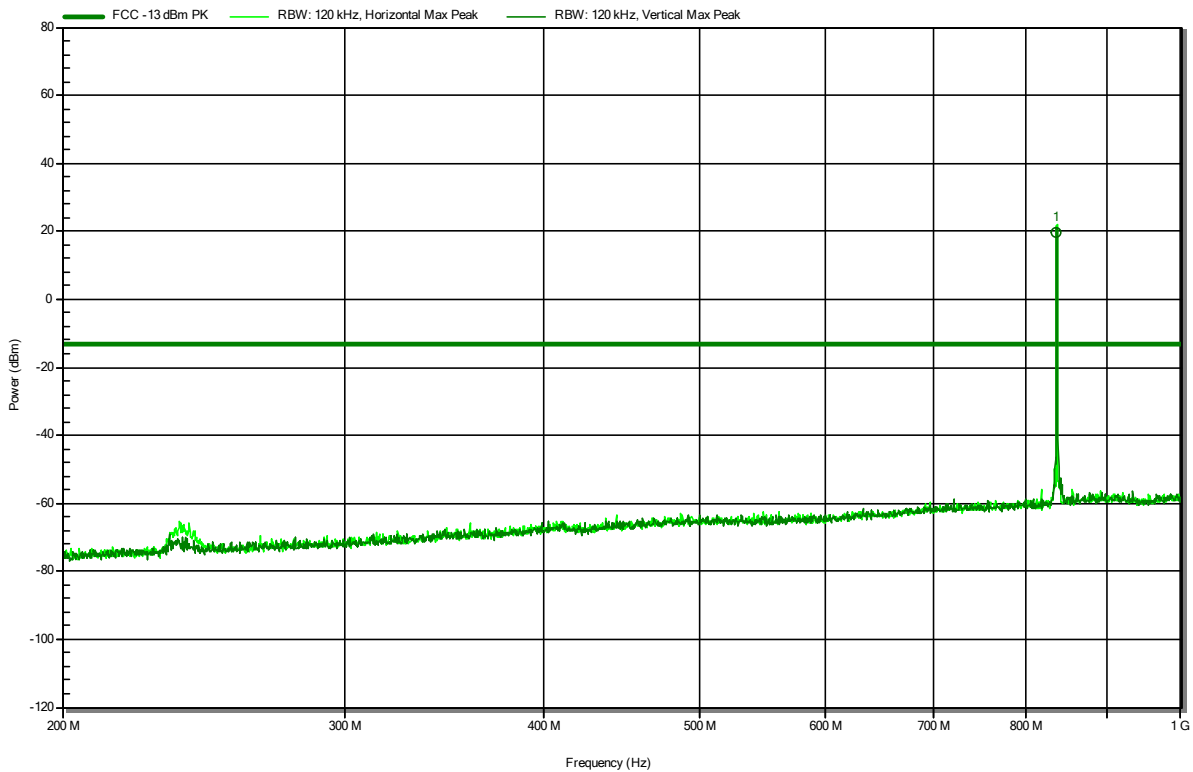

Frequency	Peak	Peak Limit	Peak Difference	Peak Status
836.4 MHz	19.7 dBm	-13 dBm		UL - Carrier

Radiated Spurious Emissions according to 47 CFR Part 22 Subpart H, RSS-132, Issue 3

Project Number: G0M-2108-9942
 Applicant: Bridgestone Mobility Solutions B.V.
 Model Description: Telematic Device with GSM+LTE+GNSS+OBD connector
 Model: L0245
 Test Sample ID: 38032 (SN: WY4481I00006)
 Test Site: Eurofins Product Service GmbH
 Operator: Mr. Degenhardt
 Measurement software: RadiMation, version 2020.1.8
 Test Conditions: Tnom: 23 °Celsius, Vnom: 12 VDC
 Antenna: Rohde & Schwarz HL 223
 Measurement distance: 3 m
 Mode: Tx; GPRS 850 Ch 189 GMSK 1xSlot Gamma 3
 Test Date: 2022-02-17
 Note: EUT vertical

Index 6

RadiMation

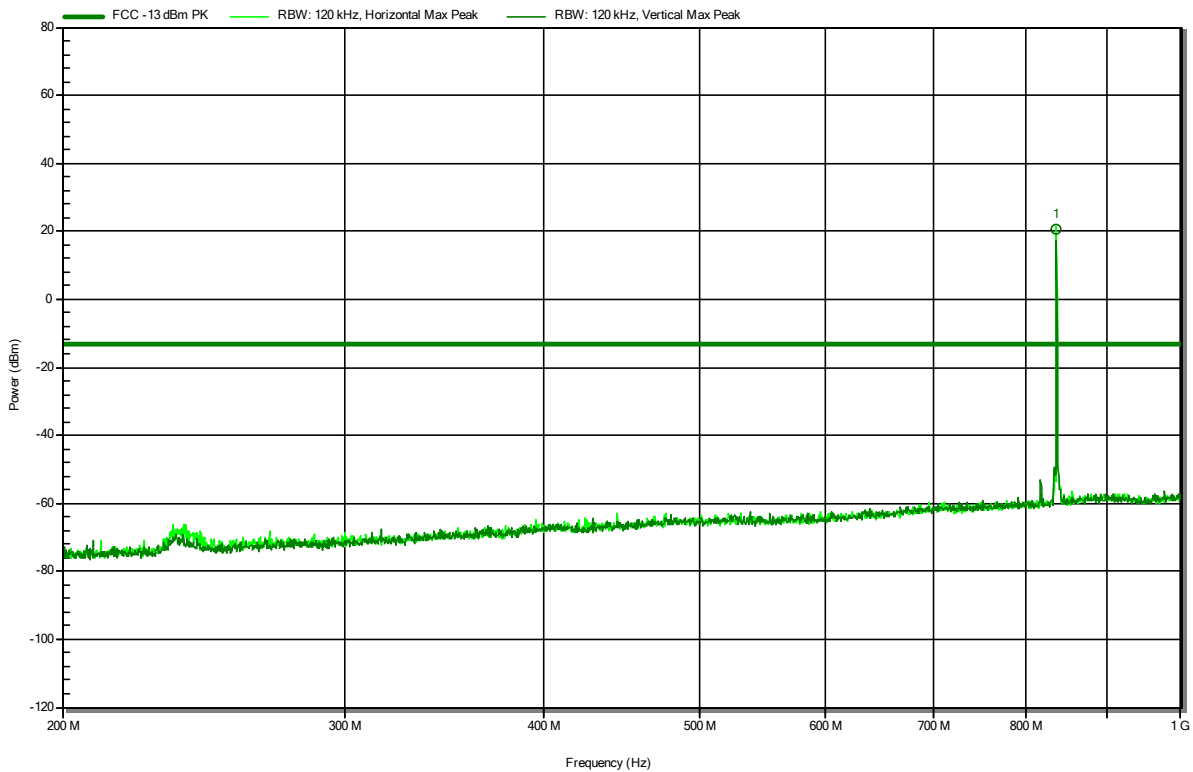

Frequency	Peak	Peak Limit	Peak Difference	Peak Status
836.26 MHz	20.5 dBm	-13 dBm		UL - Carrier

Radiated Spurious Emissions according to 47 CFR Part 22 Subpart H, RSS-132, Issue 3

Project Number: G0M-2108-9942
 Applicant: Bridgestone Mobility Solutions B.V.
 Model Description: Telematic Device with GSM+LTE+GNSS+OBD connector
 Model: L0245
 Test Sample ID: 38032 (SN: WY4481I00006)
 Test Site: Eurofins Product Service GmbH
 Operator: Mrs Hoang
 Measurement software: RadiMation, version 2020.1.8
 Test Conditions: Tnom: 23 °Celsius, Vnom: 12 VDC
 Antenna: Schwarzbeck BBHA 9120B, Horizontal
 Measurement distance: 3 m
 Mode: Tx; GPRS 850 Ch 189 GMSK 1xSlot Gamma 3
 Test Date: 2022-02-16
 Note: EUT horizontal

Index 4

RadiMation

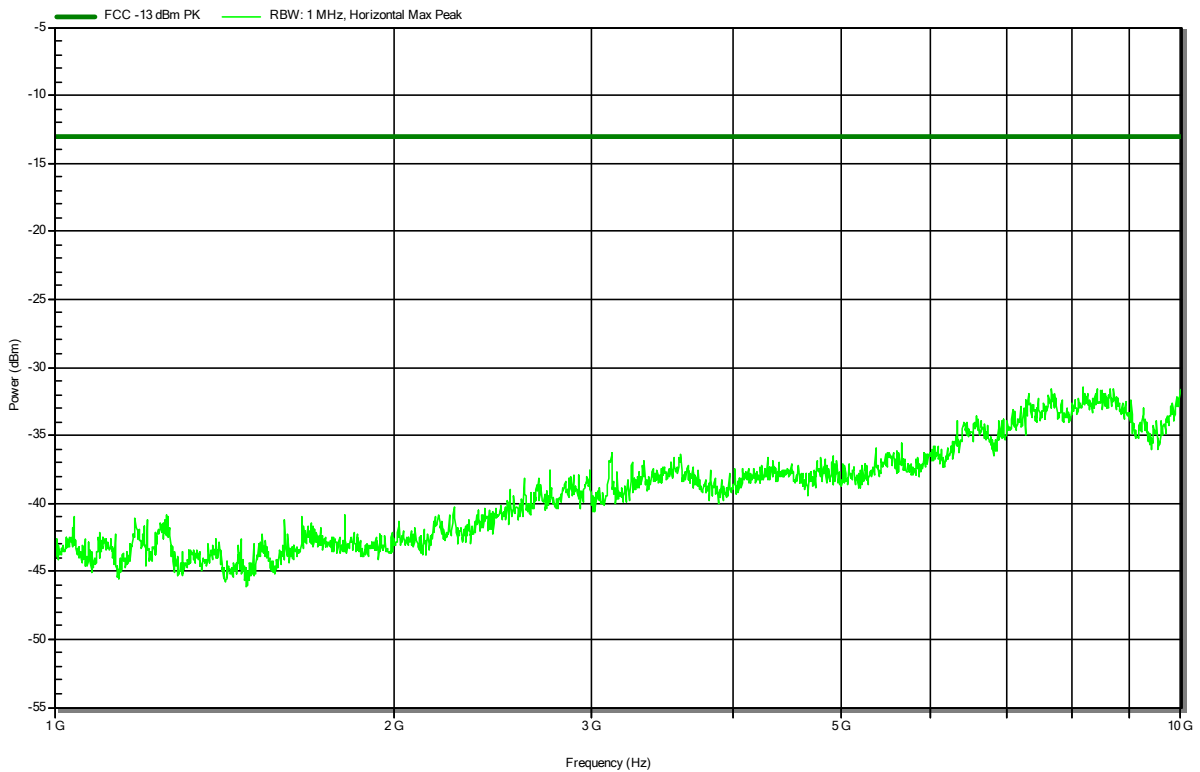

Radiated Spurious Emissions according to 47 CFR Part 22 Subpart H, RSS-132, Issue 3

Project Number: G0M-2108-9942
 Applicant: Bridgestone Mobility Solutions B.V.
 Model Description: Telematic Device with GSM+LTE+GNSS+OBD connector
 Model: L0245
 Test Sample ID: 38032 (SN: WY4481I00006)
 Test Site: Eurofins Product Service GmbH
 Operator: Mrs Hoang
 Measurement software: RadiMation, version 2020.1.8
 Test Conditions: Tnom: 23 °Celsius, Vnom: 12 VDC
 Antenna: Schwarzbeck BBHA 9120B, Horizontal
 Measurement distance: 3 m
 Mode: Tx; GPRS 850 Ch 189 GMSK 1xSlot Gamma 3
 Test Date: 2022-02-16
 Note: EUT vertical

Index 5

RadiMation

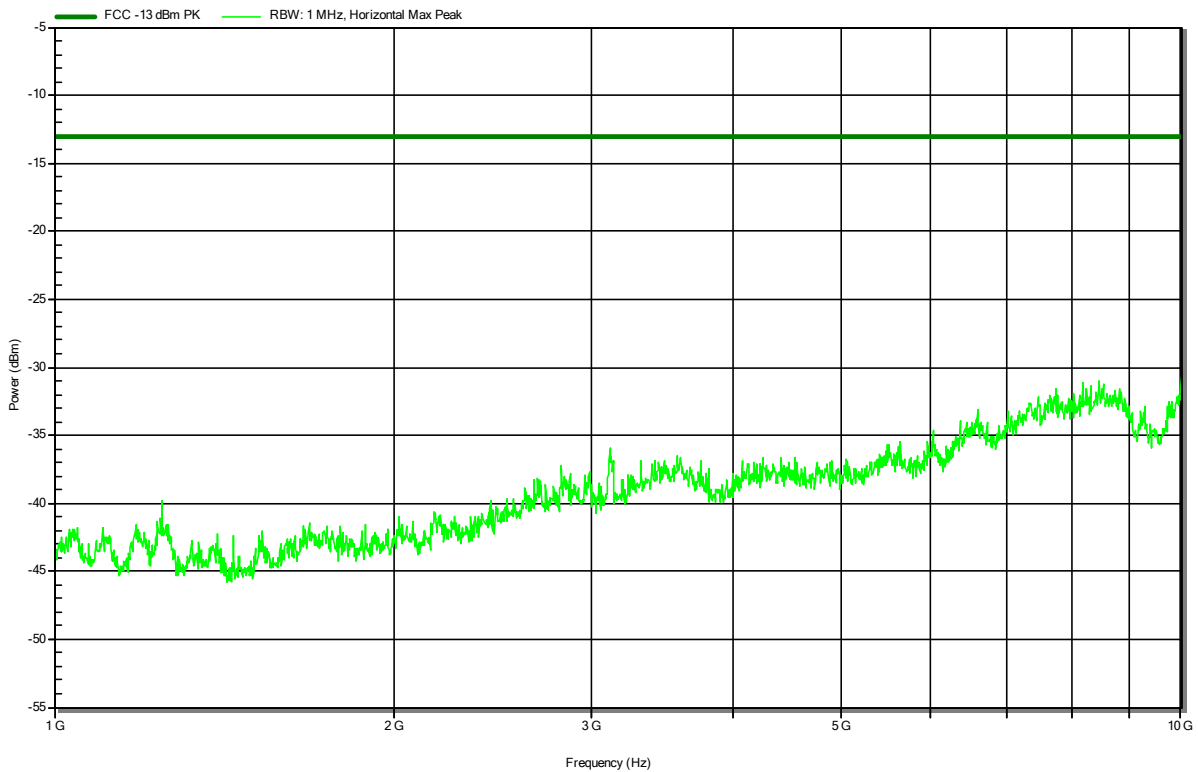

Radiated Spurious Emissions according to 47 CFR Part 22 Subpart H, RSS-132, Issue 3

Project Number: G0M-2108-9942
 Applicant: Bridgestone Mobility Solutions B.V.
 Model Description: Telematic Device with GSM+LTE+GNSS+OBD connector
 Model: L0245
 Test Sample ID: 38032 (SN: WY4481I00006)
 Test Site: Eurofins Product Service GmbH
 Operator: Mrs Hoang
 Measurement software: RadiMation, version 2020.1.8
 Test Conditions: Tnom: 23 °Celsius, Vnom: 12 VDC
 Antenna: Schwarzbeck BBHA 9120B, Vertical
 Measurement distance: 3 m
 Mode: Tx; GPRS 850 Ch 189 GMSK 1xSlot Gamma 3
 Test Date: 2022-02-16
 Note: EUT horizontal

Index 3

RadiMation

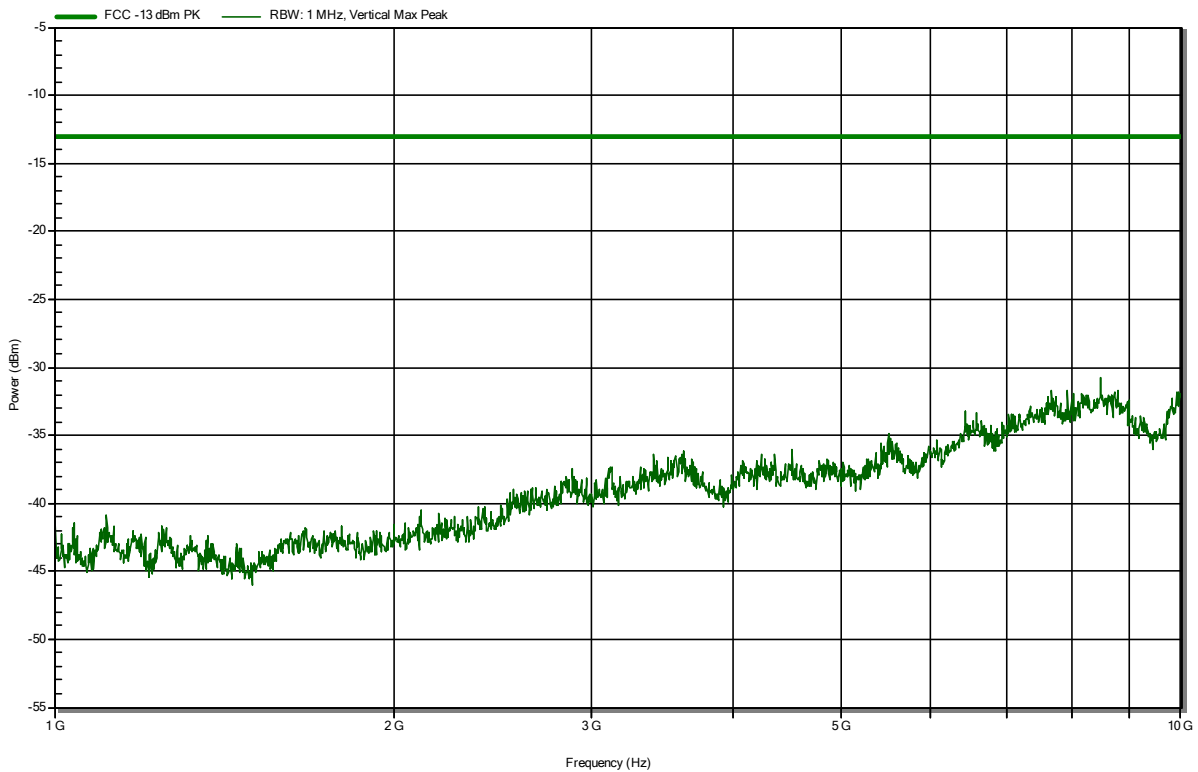

Radiated Spurious Emissions according to 47 CFR Part 22 Subpart H, RSS-132, Issue 3

Project Number: G0M-2108-9942
 Applicant: Bridgestone Mobility Solutions B.V.
 Model Description: Telematic Device with GSM+LTE+GNSS+OBD connector
 Model: L0245
 Test Sample ID: 38032 (SN: WY4481I00006)
 Test Site: Eurofins Product Service GmbH
 Operator: Mrs Hoang
 Measurement software: RadiMation, version 2020.1.8
 Test Conditions: Tnom: 23 °Celsius, Vnom: 12 VDC
 Antenna: Schwarzbeck BBHA 9120B, Vertical
 Measurement distance: 3 m
 Mode: Tx; GPRS 850 Ch 189 GMSK 1xSlot Gamma 3
 Test Date: 2022-02-16
 Note: EUT vertical

Index 1

RadiMation

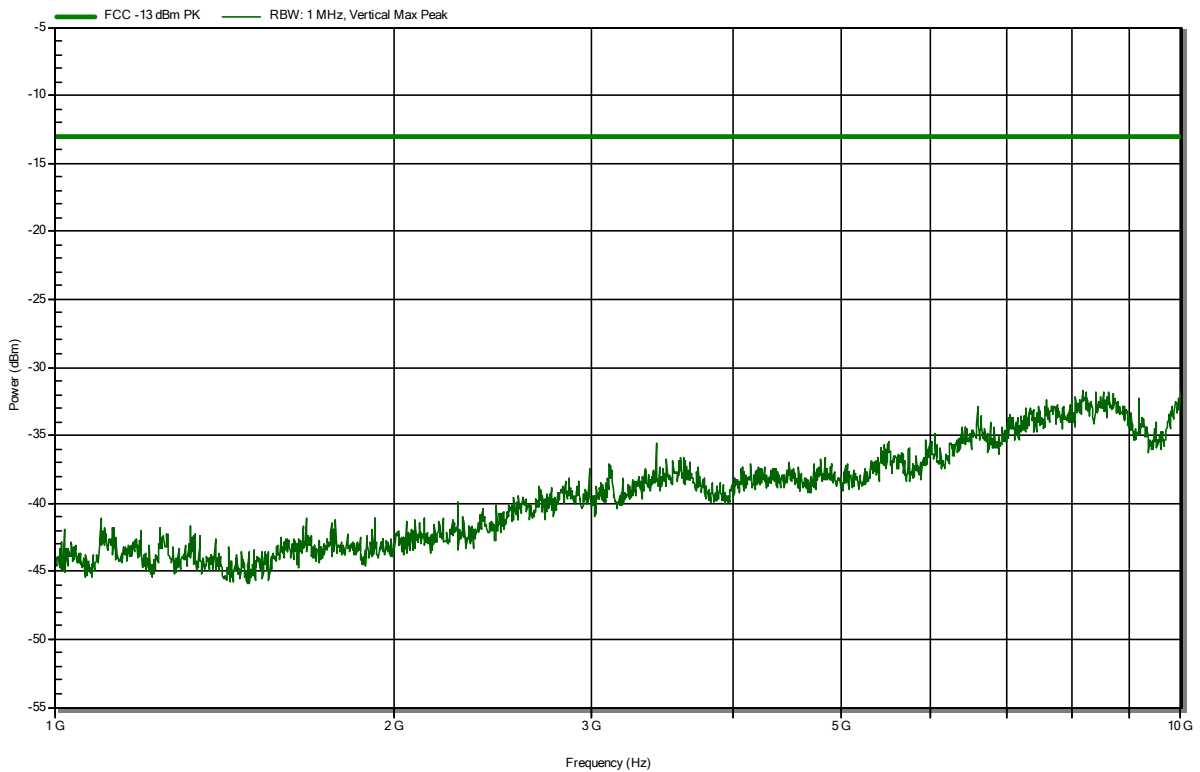

Radiated Spurious Emissions according to 47 CFR Part 24 Subpart E, RSS-133, Issue 6 + A1

Project Number: G0M-2108-9942
 Applicant: Bridgestone Mobility Solutions B.V.
 Model Description: Telematic Device with GSM+LTE+GNSS+OBD connector
 Model: L0245
 Test Sample ID: 38032 (SN: WY4481I00006)
 Test Site: Eurofins Product Service GmbH
 Operator: Mr. Degenhardt
 Measurement software: RadiMation, version 2020.1.8
 Test Conditions: Tnom: 23 °Celsius, Vnom: 12 VDC
 Antenna: Rohde & Schwarz HK 116
 Measurement distance: 3 m
 Mode: Tx; GPRS 1900 Ch 810 GMSK 1xSlot Gamma 3
 Test Date: 2022-02-17
 Note: EUT horizontal

Index 14

RadiMation

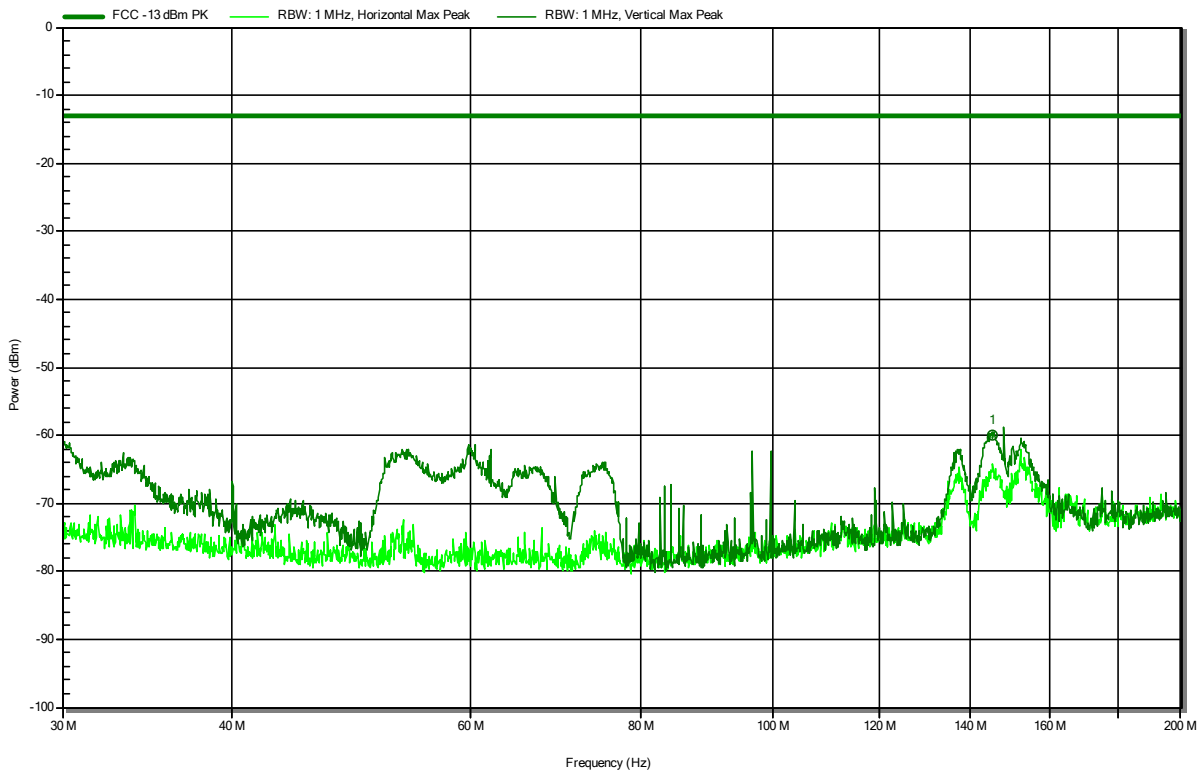

Frequency	Peak	Peak Limit	Peak Difference	Peak Status
145.375 MHz	-60 dBm	-13 dBm	-46.95 dB	Pass

Radiated Spurious Emissions according to 47 CFR Part 24 Subpart E, RSS-133, Issue 6 + A1

Project Number: G0M-2108-9942
 Applicant: Bridgestone Mobility Solutions B.V.
 Model Description: Telematic Device with GSM+LTE+GNSS+OBD connector
 Model: L0245
 Test Sample ID: 38032 (SN: WY4481I00006)
 Test Site: Eurofins Product Service GmbH
 Operator: Mr. Degenhardt
 Measurement software: RadiMation, version 2020.1.8
 Test Conditions: Tnom: 23 °Celsius, Vnom: 12 VDC
 Antenna: Rohde & Schwarz HK 116
 Measurement distance: 3 m
 Mode: Tx; GPRS 1900 Ch 810 GMSK 1xSlot Gamma 3
 Test Date: 2022-02-17
 Note: EUT vertical

Index 11

RadiMation

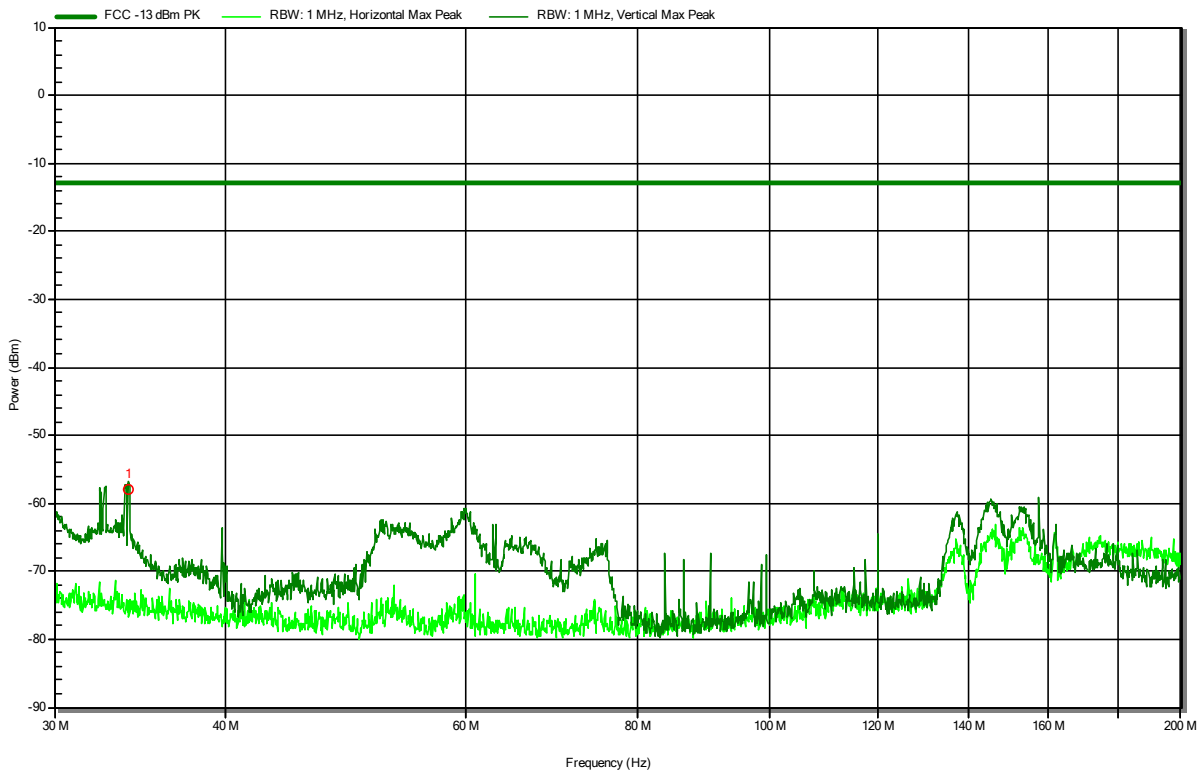

Frequency	Peak	Peak Limit	Peak Difference	Peak Status
33.978 MHz	-57.9 dBm	-13 dBm	-44.89 dB	Pass

Radiated Spurious Emissions according to 47 CFR Part 24 Subpart E, RSS-133, Issue 6 + A1

Project Number: G0M-2108-9942
 Applicant: Bridgestone Mobility Solutions B.V.
 Model Description: Telematic Device with GSM+LTE+GNSS+OBD connector
 Model: L0245
 Test Sample ID: 38032 (SN: WY4481I00006)
 Test Site: Eurofins Product Service GmbH
 Operator: Mr. Degenhardt
 Measurement software: RadiMation, version 2020.1.8
 Test Conditions: Tnom: 23 °Celsius, Vnom: 12 VDC
 Antenna: Rohde & Schwarz HL 223
 Measurement distance: 3 m
 Mode: Tx; GPRS 1900 Ch 810 GMSK 1xSlot Gamma 3
 Test Date: 2022-02-17
 Note: EUT horizontal

Index 13

RadiMation

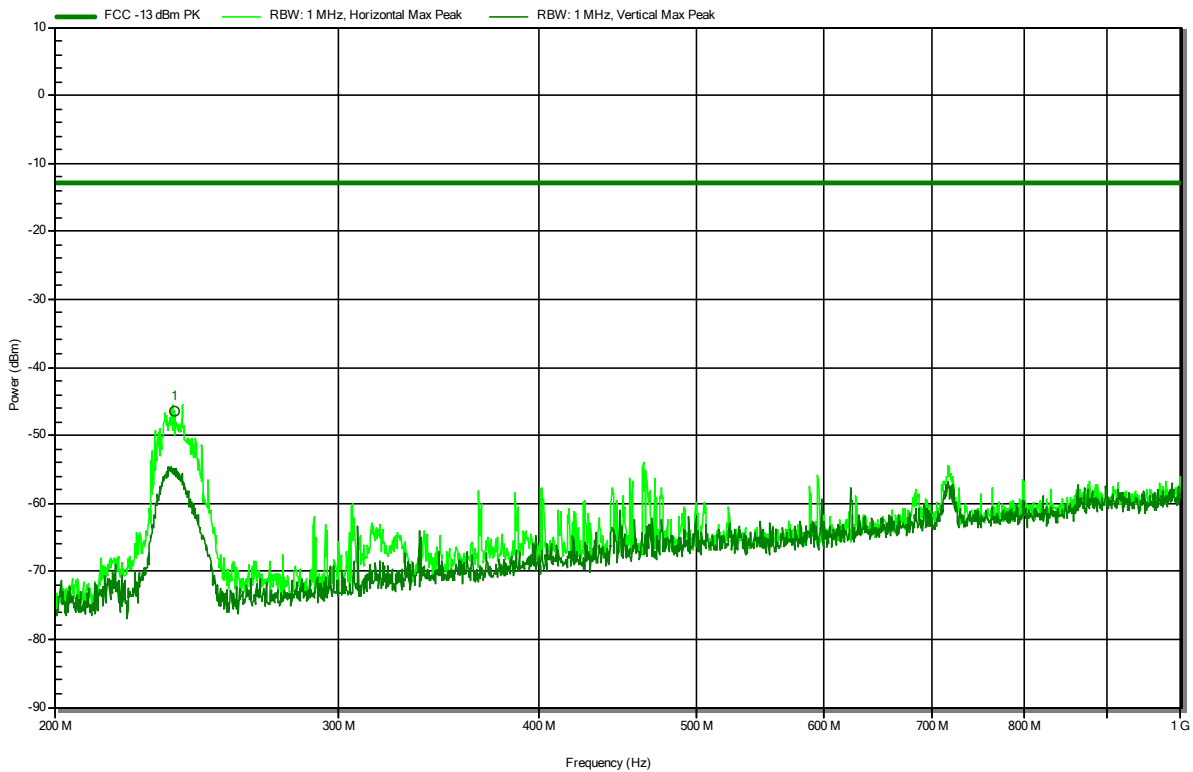

Frequency	Peak	Peak Limit	Peak Difference	Peak Status
237.58 MHz	-46.4 dBm	-13 dBm	-33.36 dB	Pass

Radiated Spurious Emissions according to 47 CFR Part 24 Subpart E, RSS-133, Issue 6 + A1

Project Number: G0M-2108-9942
 Applicant: Bridgestone Mobility Solutions B.V.
 Model Description: Telematic Device with GSM+LTE+GNSS+OBD connector
 Model: L0245
 Test Sample ID: 38032 (SN: WY4481I00006)
 Test Site: Eurofins Product Service GmbH
 Operator: Mr. Degenhardt
 Measurement software: RadiMation, version 2020.1.8
 Test Conditions: Tnom: 23 °Celsius, Vnom: 12 VDC
 Antenna: Rohde & Schwarz HL 223
 Measurement distance: 3 m
 Mode: Tx; GPRS 1900 Ch 810 GMSK 1xSlot Gamma 3
 Test Date: 2022-02-17
 Note: EUT vertical

Index 12

RadiMation

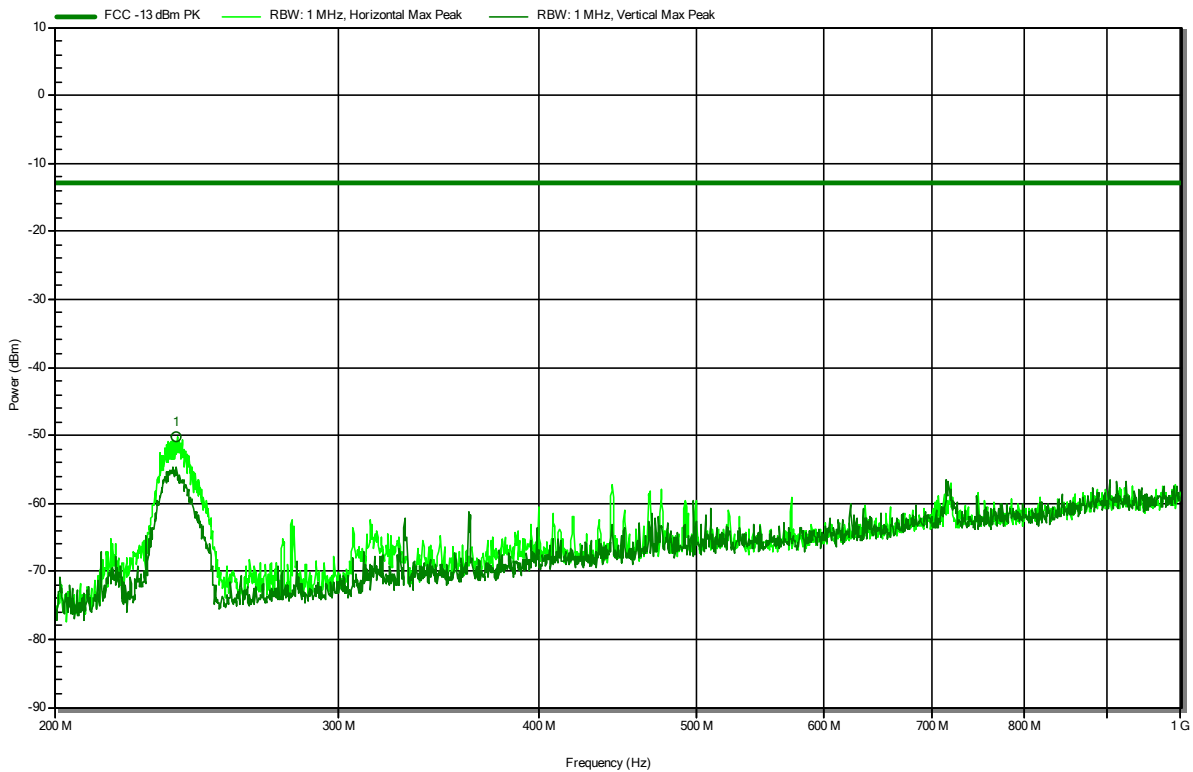

Frequency	Peak	Peak Limit	Peak Difference	Peak Status
238.16 MHz	-50.3 dBm	-13 dBm	-37.27 dB	Pass

Radiated Spurious Emissions according to 47 CFR Part 24 Subpart E, RSS-133, Issue 6 + A1

Project Number: G0M-2108-9942
 Applicant: Bridgestone Mobility Solutions B.V.
 Model Description: Telematic Device with GSM+LTE+GNSS+OBD connector
 Model: L0245
 Test Sample ID: 38032 (SN: WY4481I00006)
 Test Site: Eurofins Product Service GmbH
 Operator: Mrs Hoang
 Measurement software: RadiMation, version 2020.1.8
 Test Conditions: Tnom: 23 °Celsius, Vnom: 12 VDC
 Antenna: Schwarzbeck BBHA 9120B
 Measurement distance: 3 m
 Mode: Tx; GPRS 1900 Ch 810 GMSK 1xSlot Gamma 3
 Test Date: 2022-02-16
 Note: EUT vertical

Index 7

RadiMation

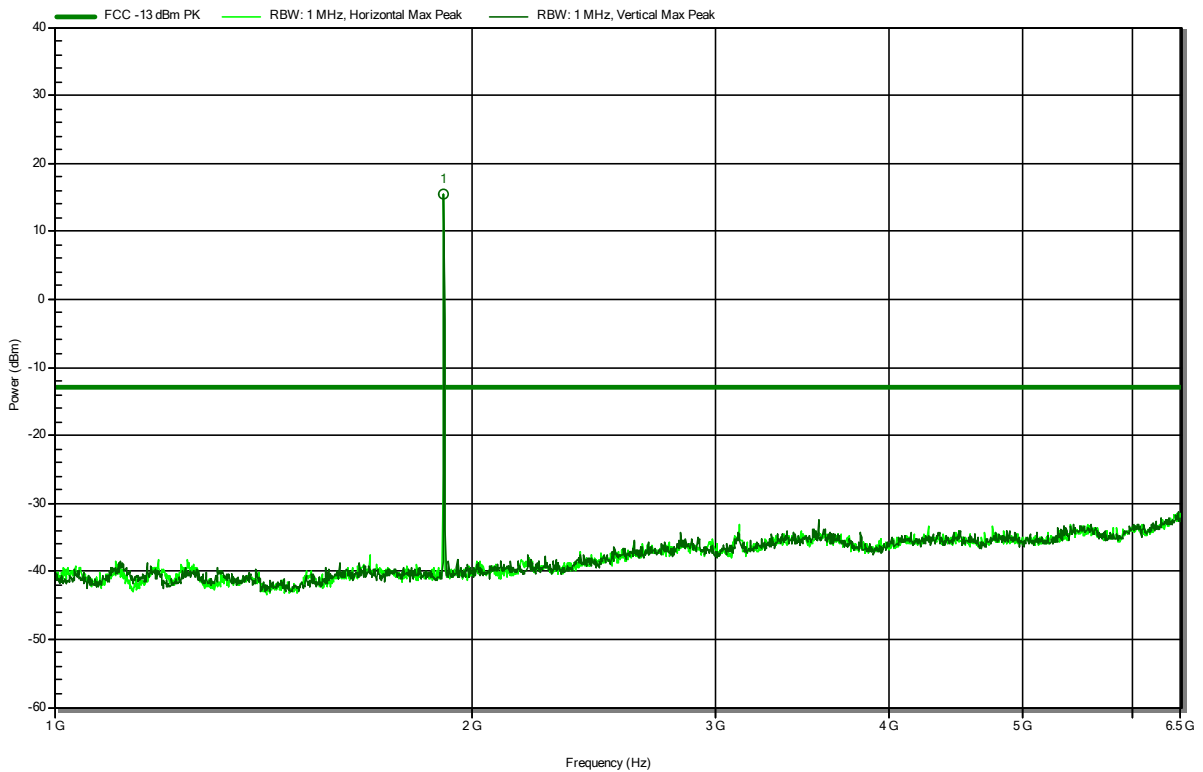

Frequency	Peak	Peak Limit	Peak Difference	Peak Status
1.91 GHz	15.4 dBm	-13 dBm		UL - Carrier

Radiated Spurious Emissions according to 47 CFR Part 24 Subpart E, RSS-133, Issue 6 + A1

Project Number: G0M-2108-9942
 Applicant: Bridgestone Mobility Solutions B.V.
 Model Description: Telematic Device with GSM+LTE+GNSS+OBD connector
 Model: L0245
 Test Sample ID: 38032 (SN: WY4481I00006)
 Test Site: Eurofins Product Service GmbH
 Operator: Mrs Hoang
 Measurement software: RadiMation, version 2020.1.8
 Test Conditions: Tnom: 23 °Celsius, Vnom: 12 VDC
 Antenna: Schwarzbeck HWRD 650
 Measurement distance: 3 m
 Mode: Tx; GPRS 1900 Ch 810 GMSK 1xSlot Gamma 3
 Test Date: 2022-02-16
 Note: EUT vertical

Index 9

RadiMation

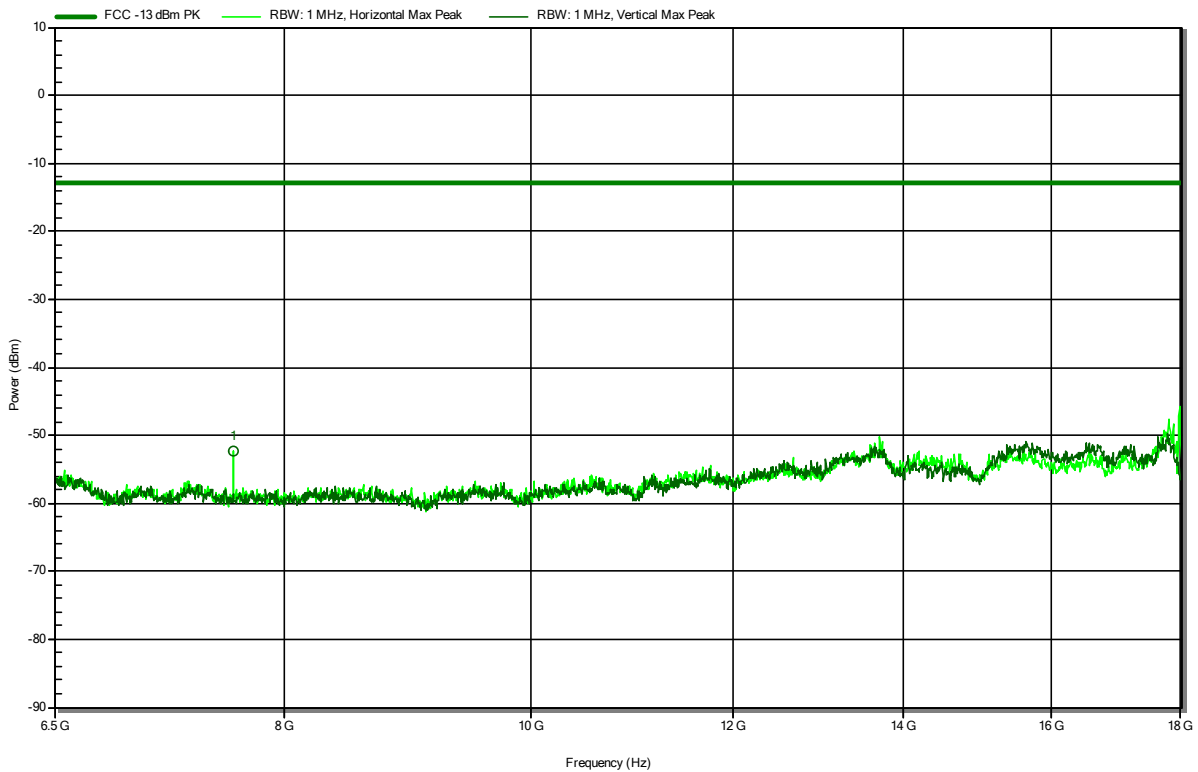

Radiated Spurious Emissions according to 47 CFR Part 24 Subpart E, RSS-133, Issue 6 + A1

Project Number: G0M-2108-9942
 Applicant: Bridgestone Mobility Solutions B.V.
 Model Description: Telematic Device with GSM+LTE+GNSS+OBD connector
 Model: L0245
 Test Sample ID: 38032 (SN: WY4481I00006)
 Test Site: Eurofins Product Service GmbH
 Operator: Mrs Hoang
 Measurement software: RadiMation, version 2020.1.8
 Test Conditions: Tnom: 23 °Celsius, Vnom: 12 VDC
 Antenna: Amplifier Research AT4560
 Measurement distance: 3 m
 Mode: Tx; GPRS 1900 Ch 810 GMSK 1xSlot Gamma 3
 Test Date: 2022-02-16
 Note: EUT vertical

Index 10

RadiMation

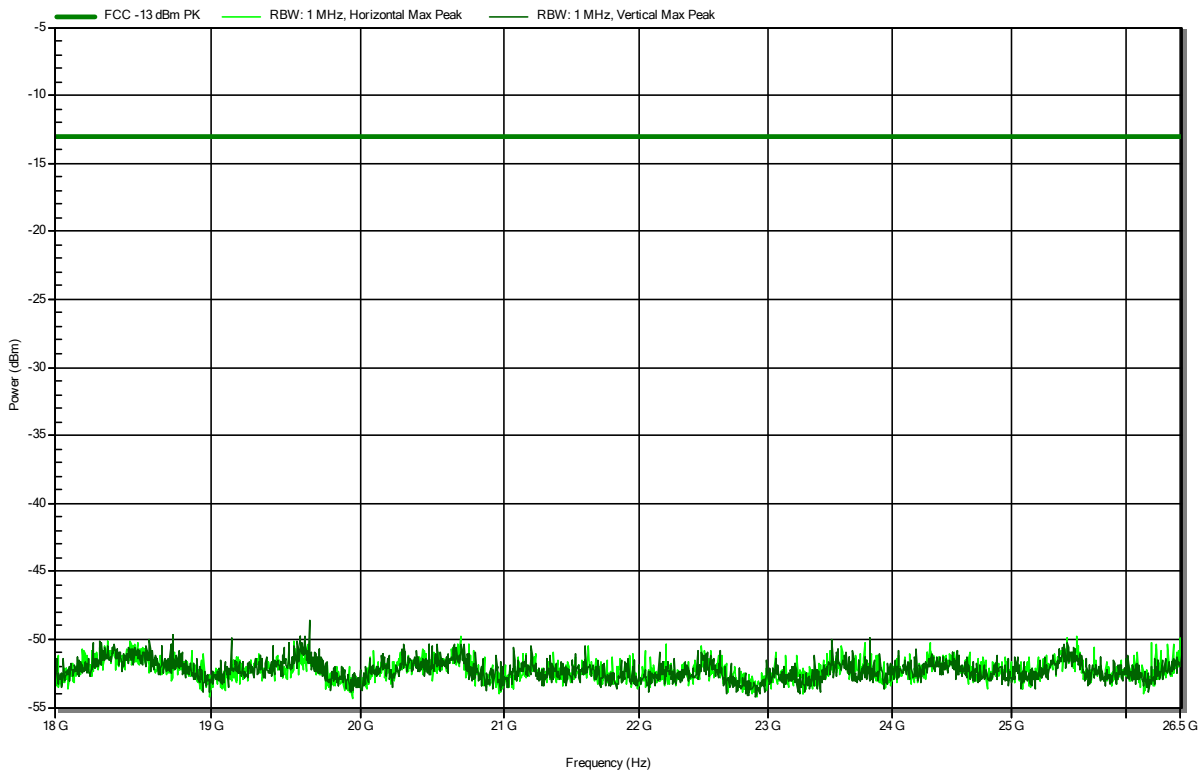

ANNEX B Receiver radiated emissions

Radiated Spurious Emissions according to RSS-132, Issue 3

Project Number: G0M-2108-9942
 Applicant: Bridgestone Mobility Solutions B.V.
 Model Description: Telematic Device with GSM+LTE+GNSS+OBD connector
 Model: L0245
 Test Sample ID: 38032 (SN: WY4481I00006)
 Test Site: Eurofins Product Service GmbH
 Operator: Mr. Degenhardt
 Measurement software: RadiMation, version 2020.1.8
 Test Conditions: Tnom: 23 °Celsius, Vnom: 12 VDC
 Antenna: Rohde & Schwarz HK 116
 Measurement distance: 3 m
 Mode: Rx; GPRS 850 Ch 189 GMSK IDLE Mode
 Test Date: 2022-02-17
 Note: EUT horizontal

Index 11

RadiMation

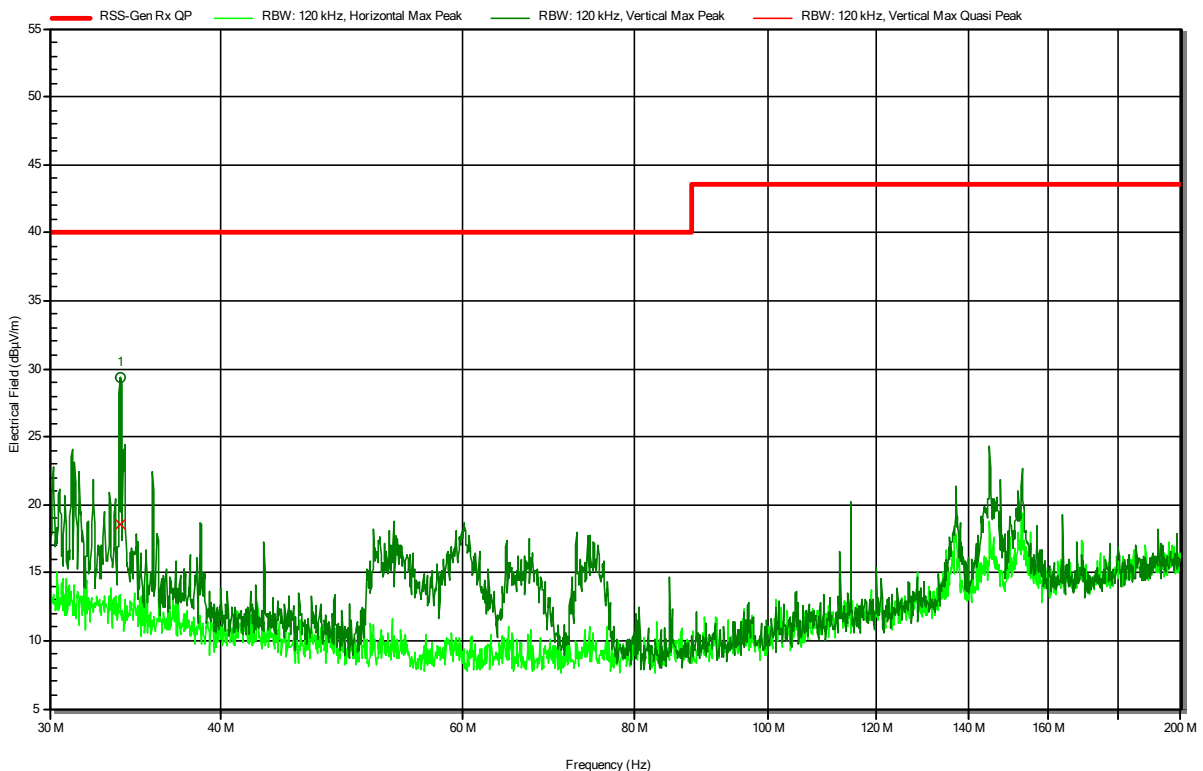

Frequency	Quasi-Peak	Quasi-Peak Limit	Quasi-Peak Difference	Quasi-Peak Status	Polarization
33.7527 MHz	18.6 dBµV/m	40 dBµV/m	-21.42 dB	Pass	Vertical

Radiated Spurious Emissions according to RSS-132, Issue 3

Project Number: G0M-2108-9942
 Applicant: Bridgestone Mobility Solutions B.V.
 Model Description: Telematic Device with GSM+LTE+GNSS+OBD connector
 Model: L0245
 Test Sample ID: 38032 (SN: WY4481I00006)
 Test Site: Eurofins Product Service GmbH
 Operator: Mr. Degenhardt
 Measurement software: RadiMation, version 2020.1.8
 Test Conditions: Tnom: 23 °Celsius, Vnom: 12 VDC
 Antenna: Rohde & Schwarz HK 116
 Measurement distance: 3 m
 Mode: Rx; GPRS 850 Ch 189 GMSK IDLE Mode
 Test Date: 2022-02-17
 Note: EUT vertical

Index 10

RadiMation

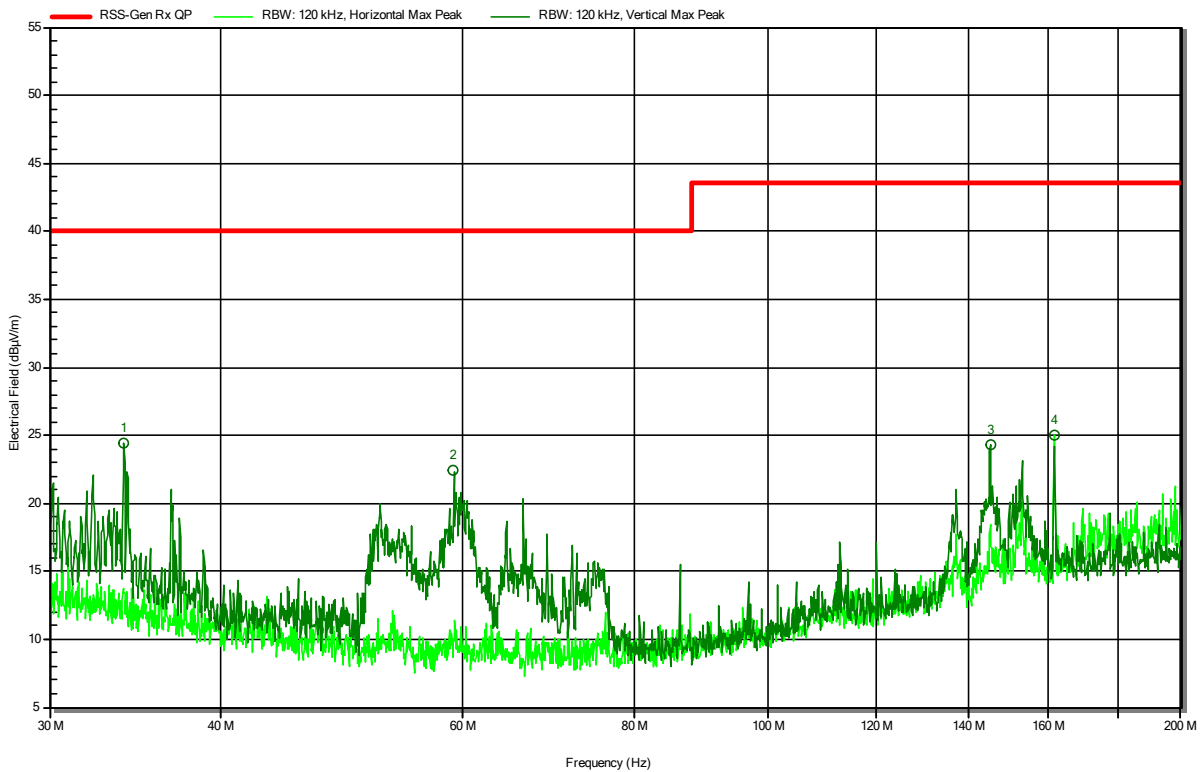

Frequency	Peak	Peak Limit	Peak Difference	Peak Status	Polarization
33.978 MHz	24.4 dBµV/m	40 dBµV/m	-15.57 dB	Pass	Vertical
59.0572 MHz	22.4 dBµV/m	40 dBµV/m	-17.63 dB	Pass	Vertical
145.2175 MHz	24.3 dBµV/m	43.5 dBµV/m	-19.25 dB	Pass	Vertical
161.6948 MHz	25 dBµV/m	43.5 dBµV/m	-18.47 dB	Pass	Horizontal

Radiated Spurious Emissions according to RSS-132, Issue 3

Project Number: G0M-2108-9942
 Applicant: Bridgestone Mobility Solutions B.V.
 Model Description: Telematic Device with GSM+LTE+GNSS+OBD connector
 Model: L0245
 Test Sample ID: 38032 (SN: WY4481I00006)
 Test Site: Eurofins Product Service GmbH
 Operator: Mr. Degenhardt
 Measurement software: RadiMation, version 2020.1.8
 Test Conditions: Tnom: 23 °Celsius, Vnom: 12 VDC
 Antenna: Rohde & Schwarz HL 223
 Measurement distance: 3 m
 Mode: Rx; GPRS 850 Ch 189 GMSK IDLE Mode
 Test Date: 2022-02-17
 Note: EUT horizontal

Index 12

RadiMation

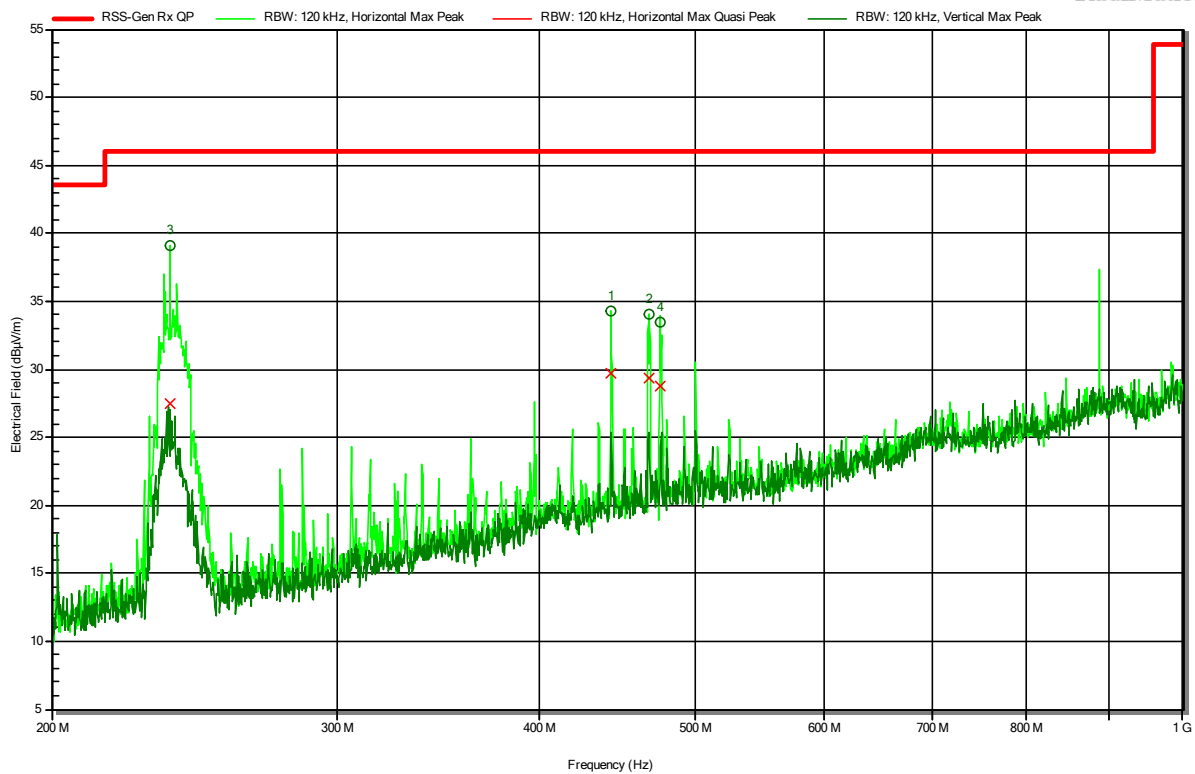

Frequency	Quasi-Peak	Quasi-Peak Limit	Quasi-Peak Difference	Quasi-Peak Status	Polarization
236.6359 MHz	27.5 dBµV/m	46 dBµV/m	-18.53 dB	Pass	Horizontal
443.58 MHz	29.7 dBµV/m	46 dBµV/m	-16.29 dB	Pass	Horizontal
467.56 MHz	29.3 dBµV/m	46 dBµV/m	-16.66 dB	Pass	Horizontal
475.8692 MHz	28.8 dBµV/m	46 dBµV/m	-17.23 dB	Pass	Horizontal

Radiated Spurious Emissions according to RSS-132, Issue 3

Project Number: G0M-2108-9942
 Applicant: Bridgestone Mobility Solutions B.V.
 Model Description: Telematic Device with GSM+LTE+GNSS+OBD connector
 Model: L0245
 Test Sample ID: 38032 (SN: WY4481I00006)
 Test Site: Eurofins Product Service GmbH
 Operator: Mr. Degenhardt
 Measurement software: RadiMation, version 2020.1.8
 Test Conditions: Tnom: 23 °Celsius, Vnom: 12 VDC
 Antenna: Rohde & Schwarz HL 223
 Measurement distance: 3 m
 Mode: Rx; GPRS 850 Ch 189 GMSK IDLE Mode
 Test Date: 2022-02-17
 Note: EUT vertical

Index 9

RadiMation

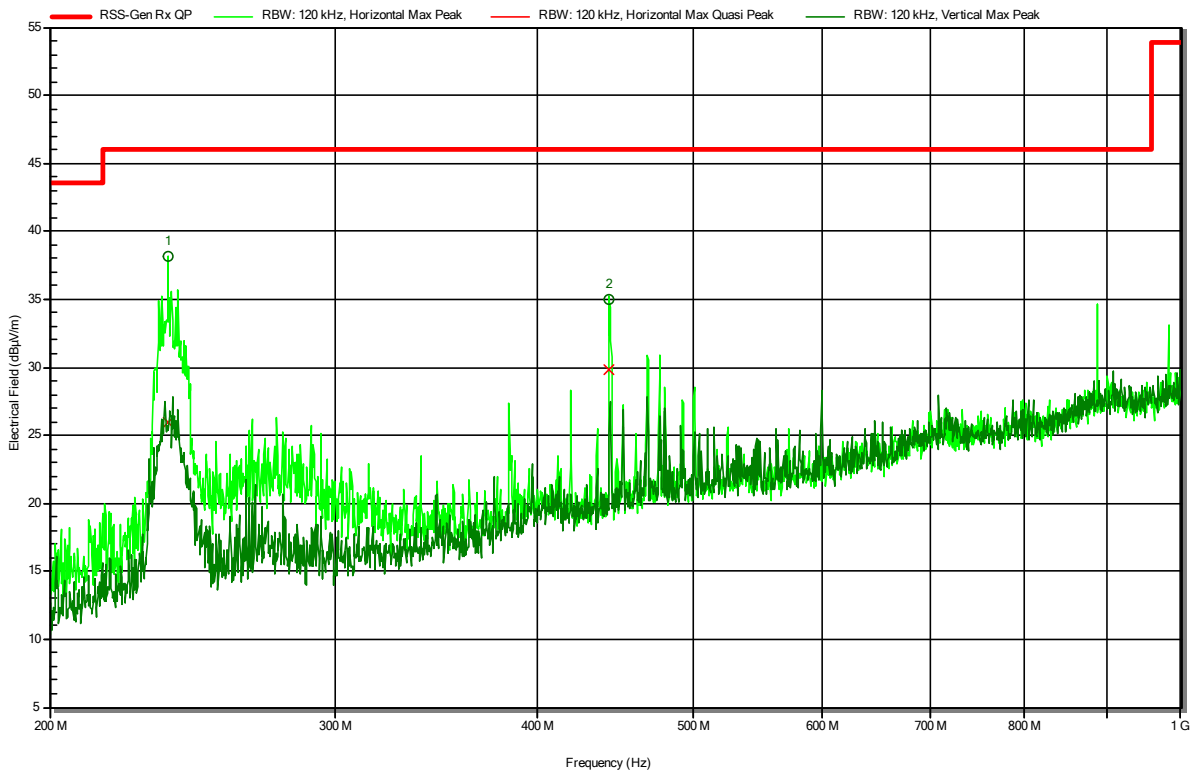

Frequency	Quasi-Peak	Quasi-Peak Limit	Quasi-Peak Difference	Quasi-Peak Status	Polarization
237.0047 MHz	26 dBµV/m	46 dBµV/m	-20.01 dB	Pass	Horizontal
443.5726 MHz	29.8 dBµV/m	46 dBµV/m	-16.2 dB	Pass	Horizontal

Radiated Spurious Emissions according to RSS-132, Issue 3

Project Number: G0M-2108-9942
 Applicant: Bridgestone Mobility Solutions B.V.
 Model Description: Telematic Device with GSM+LTE+GNSS+OBD connector
 Model: L0245
 Test Sample ID: 38032 (SN: WY4481I00006)
 Test Site: Eurofins Product Service GmbH
 Operator: Mr. Qawasmeh
 Measurement software: RadiMation, version 2020.1.8
 Test Conditions: Tnom: 23 °Celsius, Vnom: 12 VDC
 Antenna: Schwarzbeck BBHA 9120D
 Measurement distance: 3 m
 Mode: Rx; GPRS 850 Ch 189 GMSK IDLE Mode
 Test Date: 2022-02-16
 Note: EUT vertical

Index 8

RadiMation

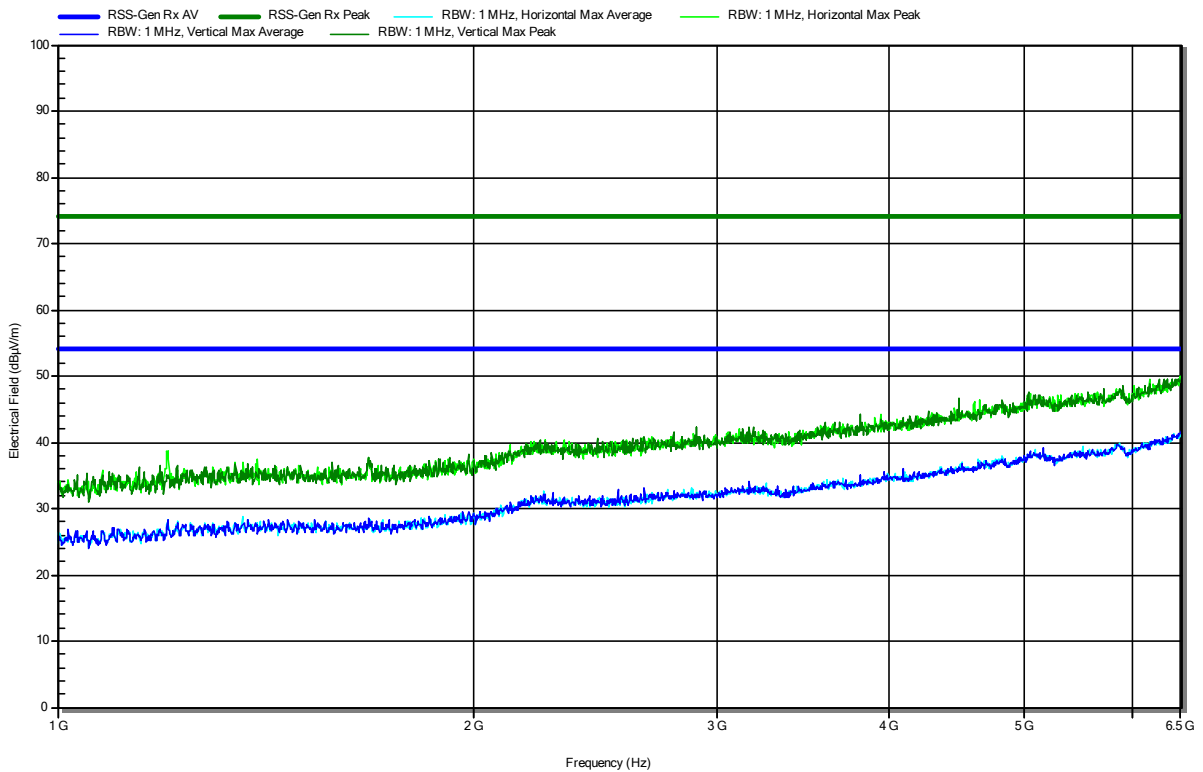

Radiated Spurious Emissions according to RSS-133, Issue 6 + A1

Project Number: G0M-2108-9942
 Applicant: Bridgestone Mobility Solutions B.V.
 Model Description: Telematic Device with GSM+LTE+GNSS+OBD connector
 Model: L0245
 Test Sample ID: 38032 (SN: WY4481I00006)
 Test Site: Eurofins Product Service GmbH
 Operator: Mr. Degenhardt
 Measurement software: RadiMation, version 2020.1.8
 Test Conditions: Tnom: 23 °Celsius, Vnom: 12 VDC
 Antenna: Rohde & Schwarz HK 116
 Measurement distance: 3 m
 Mode: Rx; GPRS 1900 Ch 810 GMSK IDLE mode
 Test Date: 2022-02-17
 Note: EUT horizontal

Index 17

RadiMation

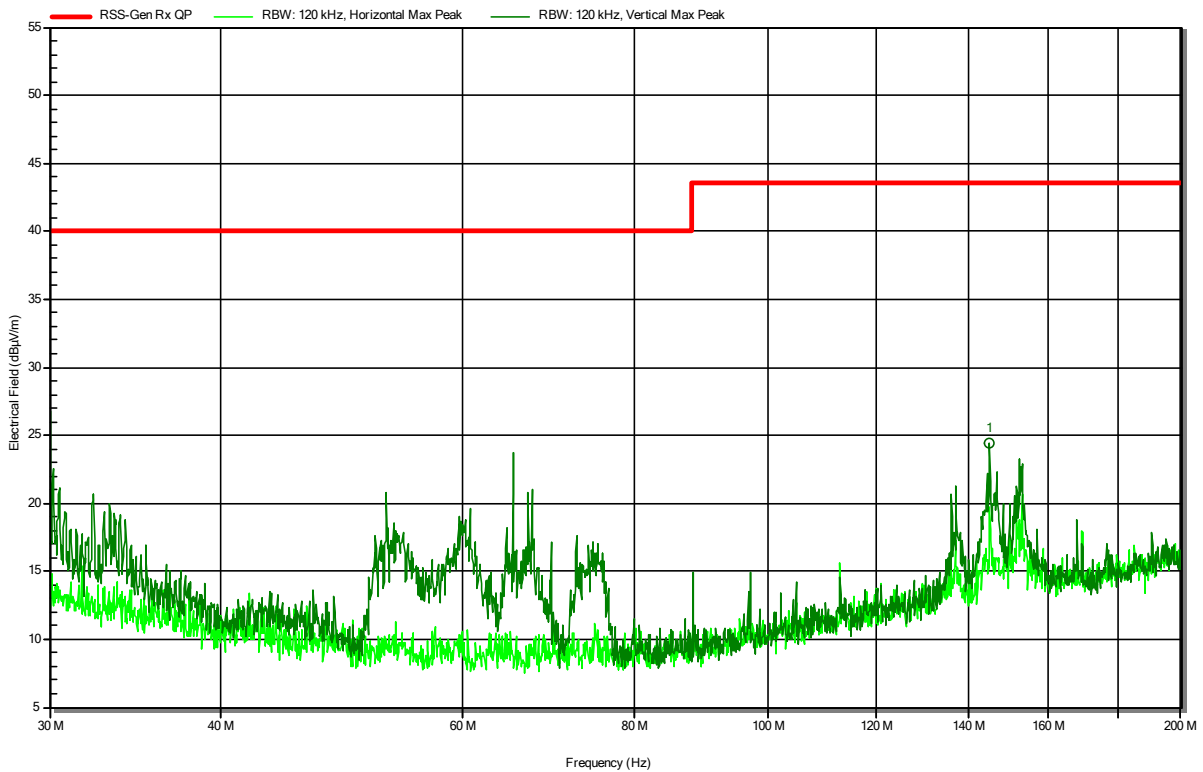

Frequency	Peak	Peak Limit	Peak Difference	Peak Status	Polarization
145.0943 MHz	24.4 dBµV/m	43.5 dBµV/m	-19.1 dB	Pass	Vertical

Radiated Spurious Emissions according to RSS-133, Issue 6 + A1

Project Number: G0M-2108-9942
 Applicant: Bridgestone Mobility Solutions B.V.
 Model Description: Telematic Device with GSM+LTE+GNSS+OBD connector
 Model: L0245
 Test Sample ID: 38032 (SN: WY4481I00006)
 Test Site: Eurofins Product Service GmbH
 Operator: Mr. Degenhardt
 Measurement software: RadiMation, version 2020.1.8
 Test Conditions: Tnom: 23 °Celsius, Vnom: 12 VDC
 Antenna: Rohde & Schwarz HK 116
 Measurement distance: 3 m
 Mode: Rx; GPRS 1900 Ch 810 GMSK IDLE mode
 Test Date: 2022-02-17
 Note: EUT vertical

Index 13

RadiMation

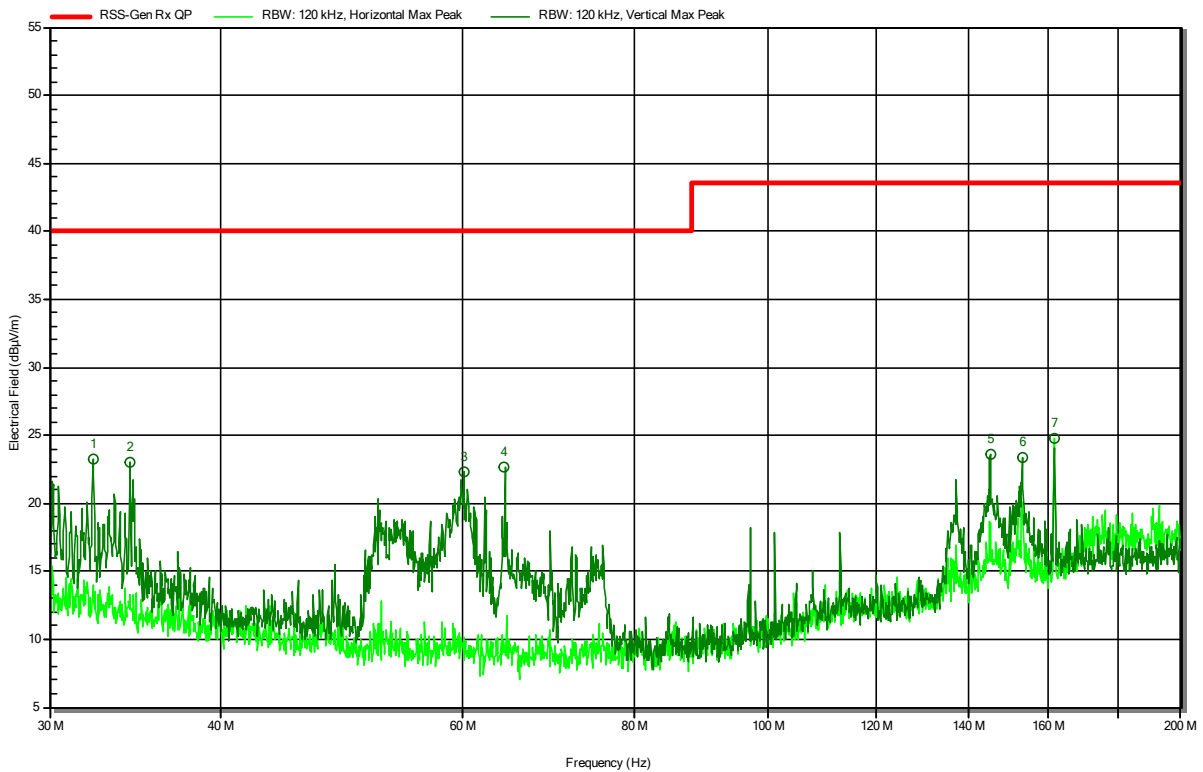

Frequency	Peak	Peak Limit	Peak Difference	Peak Status	Polarization
32.244 MHz	23.2 dBµV/m	40 dBµV/m	-16.78 dB	Pass	Vertical
34.284 MHz	23 dBµV/m	40 dBµV/m	-16.97 dB	Pass	Vertical
60.056 MHz	22.4 dBµV/m	40 dBµV/m	-17.63 dB	Pass	Vertical
64.306 MHz	22.7 dBµV/m	40 dBµV/m	-17.28 dB	Pass	Vertical
145.2303 MHz	23.6 dBµV/m	43.5 dBµV/m	-19.87 dB	Pass	Vertical
153.2543 MHz	23.4 dBµV/m	43.5 dBµV/m	-20.11 dB	Pass	Vertical
161.6948 MHz	24.8 dBµV/m	43.5 dBµV/m	-18.75 dB	Pass	Horizontal

Radiated Spurious Emissions according to RSS-133, Issue 6 + A1

Project Number: G0M-2108-9942
 Applicant: Bridgestone Mobility Solutions B.V.
 Model Description: Telematic Device with GSM+LTE+GNSS+OBD connector
 Model: L0245
 Test Sample ID: 38032 (SN: WY4481I00006)
 Test Site: Eurofins Product Service GmbH
 Operator: Mr. Degenhardt
 Measurement software: RadiMation, version 2020.1.8
 Test Conditions: Tnom: 23 °Celsius, Vnom: 12 VDC
 Antenna: Rohde & Schwarz HL 223
 Measurement distance: 3 m
 Mode: Rx; GPRS 1900 Ch 810 GMSK IDLE mode
 Test Date: 2022-02-17
 Note: EUT horizontal

Index 16

RadiMation

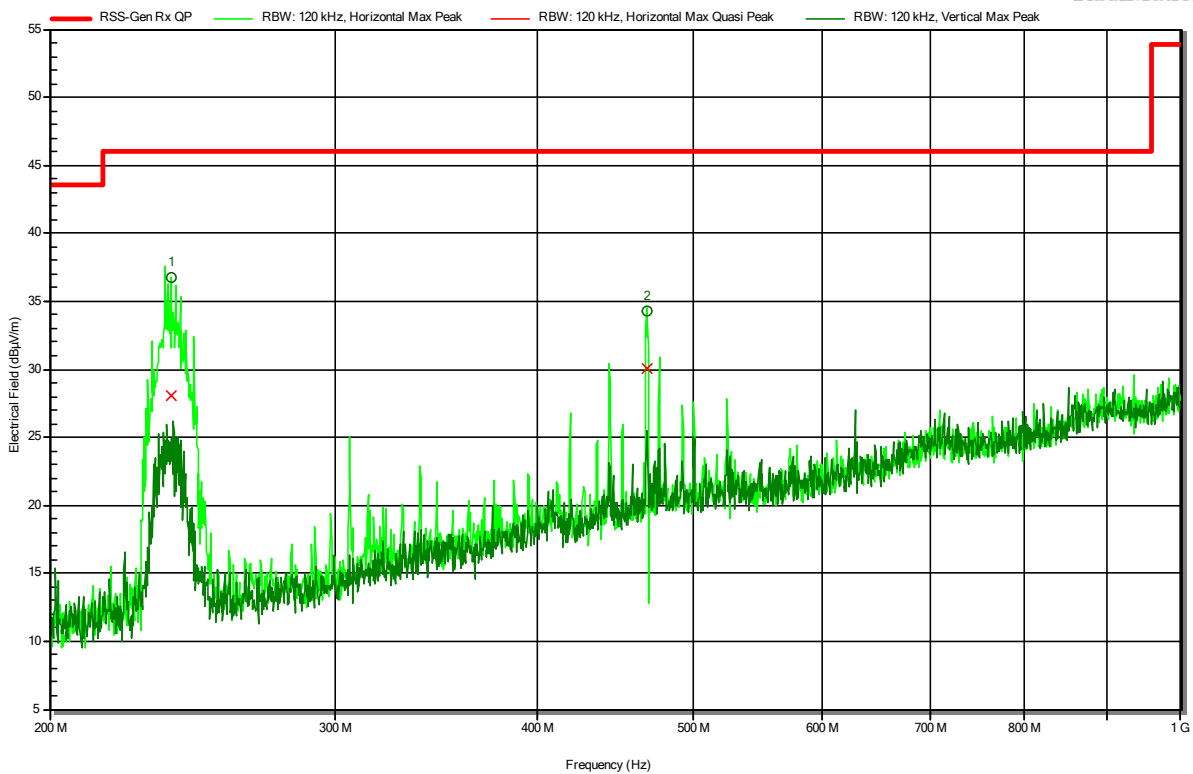

Frequency	Quasi-Peak	Quasi-Peak Limit	Quasi-Peak Difference	Quasi-Peak Status	Polarization
237.88 MHz	28.1 dBµV/m	46 dBµV/m	-17.92 dB	Pass	Horizontal
467.68 MHz	30 dBµV/m	46 dBµV/m	-15.97 dB	Pass	Horizontal

Radiated Spurious Emissions according to RSS-133, Issue 6 + A1

Project Number: G0M-2108-9942
 Applicant: Bridgestone Mobility Solutions B.V.
 Model Description: Telematic Device with GSM+LTE+GNSS+OBD connector
 Model: L0245
 Test Sample ID: 38032 (SN: WY4481I00006)
 Test Site: Eurofins Product Service GmbH
 Operator: Mr. Degenhardt
 Measurement software: RadiMation, version 2020.1.8
 Test Conditions: Tnom: 23 °Celsius, Vnom: 12 VDC
 Antenna: Rohde & Schwarz HL 223
 Measurement distance: 3 m
 Mode: Rx; GPRS 1900 Ch 810 GMSK IDLE mode
 Test Date: 2022-02-17
 Note: EUT vertical

Index 15

RadiMation

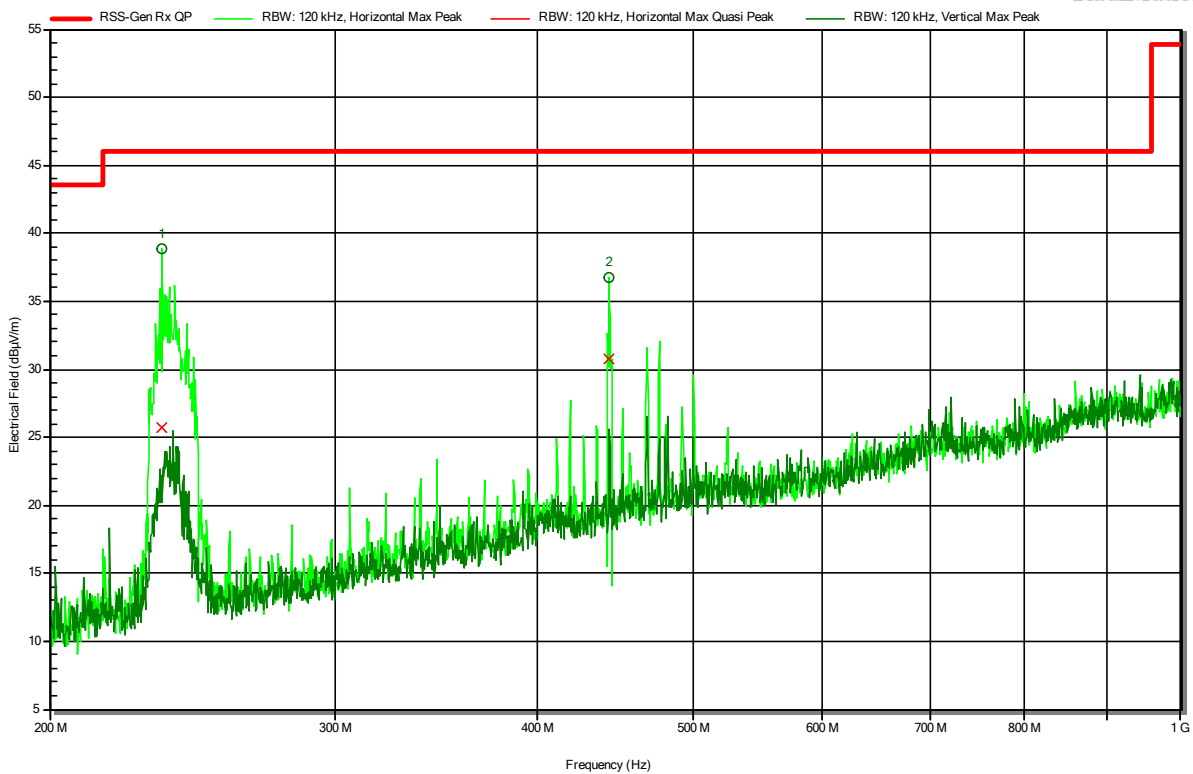

Frequency	Quasi-Peak	Quasi-Peak Limit	Quasi-Peak Difference	Quasi-Peak Status	Polarization
234.5696 MHz	25.7 dBµV/m	46 dBµV/m	-20.34 dB	Pass	Horizontal
443.4821 MHz	30.7 dBµV/m	46 dBµV/m	-15.26 dB	Pass	Horizontal

Radiated Spurious Emissions according to RSS-133, Issue 6 + A1

Project Number: G0M-2108-9942
 Applicant: Bridgestone Mobility Solutions B.V.
 Model Description: Telematic Device with GSM+LTE+GNSS+OBD connector
 Model: L0245
 Test Sample ID: 38032 (SN: WY4481I00006)
 Test Site: Eurofins Product Service GmbH
 Operator: Mr. Qawasmeh
 Measurement software: RadiMation, version 2020.1.8
 Test Conditions: Tnom: 23 °Celsius, Vnom: 12 VDC
 Antenna: Schwarzbeck BBHA 9120D
 Measurement distance: 3 m
 Mode: Rx; GPRS 1900 Ch 810 GMSK IDLE mode
 Test Date: 2022-02-16
 Note: EUT vertical

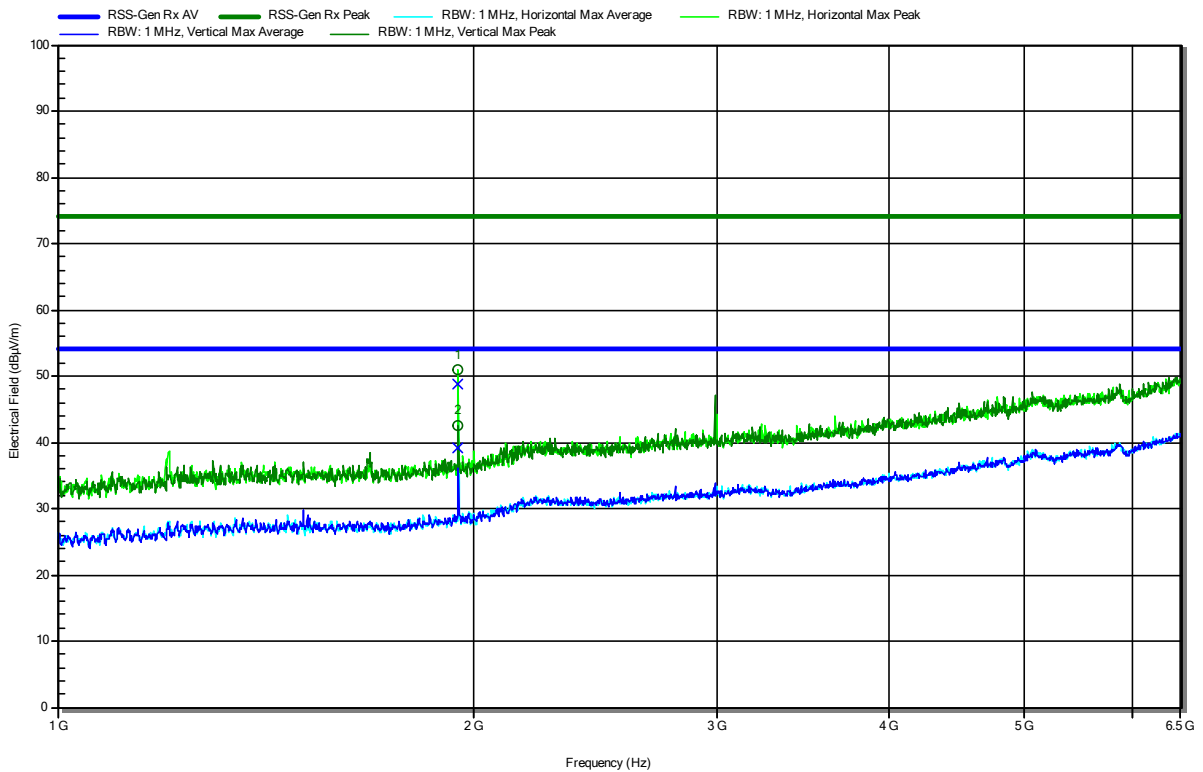

Frequency	Average	Average Limit	Average Difference	Average Status	Polarization
1.948 GHz	48.78 dBµV/m	53.98 dBµV/m		BCCH - Carrier	Horizontal
1.948 GHz	39.16 dBµV/m	53.98 dBµV/m		BCCH - Carrier	Vertical

Radiated Spurious Emissions according to RSS-133, Issue 6 + A1

Project Number: G0M-2108-9942
 Applicant: Bridgestone Mobility Solutions B.V.
 Model Description: Telematic Device with GSM+LTE+GNSS+OBD connector
 Model: L0245
 Test Sample ID: 38032 (SN: WY4481I00006)
 Test Site: Eurofins Product Service GmbH
 Operator: Mr. Qawasmeh
 Measurement software: RadiMation, version 2020.1.8
 Test Conditions: Tnom: 23 °Celsius, Vnom: 12 VDC
 Antenna: Schwarzbeck HWRD 650
 Measurement distance: 3 m
 Mode: Rx; GPRS 1900 Ch 810 GMSK IDLE mode
 Test Date: 2022-02-16
 Note: EUT vertical

Index 11

RadiMation

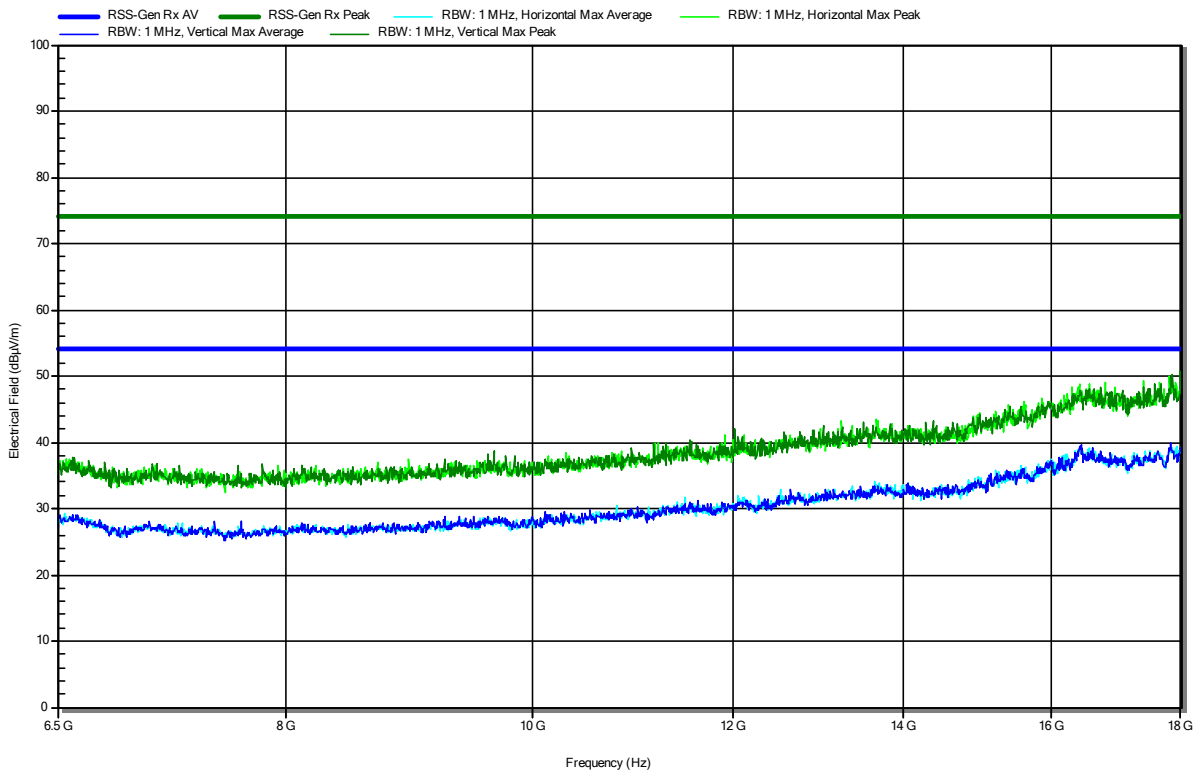

=== End of test report ===