



FCC RADIO TEST REPORT

FCC ID : 2AGOZ-P97
Equipment : VR Headset
Brand Name : 
Model Name : P97
Applicant : Meta Platforms Technologies, LLC.
 1 Hacker Way, Menlo Park, CA 94025, USA
Manufacturer : Meta Platforms Technologies, LLC.
 1 Hacker Way, Menlo Park, CA 94025, USA
Standard : FCC Part 15 Subpart C §15.247

The product was received on Apr. 03, 2024 and testing was performed from Apr. 11, 2024 to May 18, 2024. We, Sporton International Inc. Wensan Laboratory, would like to declare that the tested sample has been evaluated in accordance with the test procedures and has been in compliance with the applicable technical standards.

The test results in this report apply exclusively to the tested model / sample. Without written approval from Sporton International Inc. Wensan Laboratory, the test report shall not be reproduced except in full.

Louis Wu

Approved by: Louis Wu

Sporton International Inc. Wensan Laboratory

No.58, Aly. 75, Ln. 564, Wenhua 3rd, Rd., Guishan Dist., Taoyuan City 333010, Taiwan (R.O.C.)



Table of Contents

History of this test report..... 3

Summary of Test Result..... 4

1 General Description..... 5

 1.1 Product Feature of Equipment Under Test..... 5

 1.2 Modification of EUT 5

 1.3 Testing Location 5

 1.4 Applicable Standards..... 6

2 Test Configuration of Equipment Under Test 7

 2.1 Carrier Frequency Channel 7

 2.2 Test Mode..... 8

 2.3 Connection Diagram of Test System..... 9

 2.4 Support Unit used in test configuration and system 10

 2.5 EUT Operation Test Setup 10

 2.6 Measurement Results Explanation Example..... 10

3 Test Result..... 11

 3.1 6dB and 99% Bandwidth Measurement 11

 3.2 Output Power Measurement..... 12

 3.3 Power Spectral Density Measurement 13

 3.4 Conducted Band Edges and Spurious Emission Measurement 14

 3.5 Radiated Band Edges and Spurious Emission Measurement 15

 3.6 AC Conducted Emission Measurement..... 19

 3.7 Antenna Requirements 21

4 List of Measuring Equipment 22

5 Measurement Uncertainty 24

Appendix A. Conducted Test Results

Appendix B. AC Conducted Emission Test Result

Appendix C. Radiated Spurious Emission

Appendix D. Radiated Spurious Emission Plots

Appendix E. Duty Cycle Plots

Appendix F. Setup Photographs



History of this test report

Report No.	Version	Description	Issue Date
FR413013-01H	01	Initial issue of report	May 29, 2024



Summary of Test Result

Report Clause	Ref Std. Clause	Test Items	Result (PASS/FAIL)	Remark
3.1	15.247(a)(2)	6dB Bandwidth	Pass	-
3.1	2.1049	99% Occupied Bandwidth	Reporting only	-
3.2	15.247(b)(3) 15.247(b)(4)	Output Power	Pass	-
3.3	15.247(e)	Power Spectral Density	Pass	-
3.4	15.247(d)	Conducted Band Edges and Spurious Emission	Pass	-
3.5	15.247(d)	Radiated Band Edges and Spurious Emission	Pass	6.24 dB under the limit at 45.66 MHz
3.6	15.207	AC Conducted Emission	Pass	3.50 dB under the limit at 0.16 MHz
3.7	15.203	Antenna Requirement	Pass	-

Conformity Assessment Condition:

1. The test results (PASS/FAIL) with all measurement uncertainty excluded are presented against the regulation limits or in accordance with the requirements stipulated by the applicant/manufacturer who shall bear all the risks of non-compliance that may potentially occur if measurement uncertainty is taken into account.
2. The measurement uncertainty please refer to each test result in the section "Measurement Uncertainty".

Disclaimer:

The product specifications of the EUT presented in the test report that may affect the test assessments are declared by the manufacturer who shall take full responsibility for the authenticity.

Reviewed by: Yun Huang

Report Producer: Lucy Wu



1 General Description

1.1 Product Feature of Equipment Under Test

Product Feature	
General Specs	Bluetooth, Wi-Fi 2.4GHz 802.11b/g/n/ac/ax, Wi-Fi 5GHz 802.11a/n/ac/ax, Wi-Fi 6GHz 802.11ax and nRF.
Sample 1	E2-C1
Sample 2	E2-C2
Sample 3	E2-C3
Sample 4	E2-C4
Antenna Type	Bluetooth: <Ant. 0>: Hybrid Slot Monopole Antenna <Ant. 1>: Hybrid Slot Monopole Antenna WLAN: <Ant. 0>: Hybrid Slot Monopole Antenna <Ant. 1>: Hybrid Slot Monopole Antenna nRF: Folded Dipole Antenna

Antenna information		
2400 MHz ~ 2483.5 MHz	Peak Gain (dBi)	4.5

Remark: The EUT's information above is declared by manufacturer. Please refer to Disclaimer in report summary.

1.2 Modification of EUT

No modifications made to the EUT during the testing.

1.3 Testing Location

Test Site	Sporton International Inc. Wensan Laboratory
Test Site Location	No.58, Aly. 75, Ln. 564, Wenhua 3rd, Rd., Guishan Dist., Taoyuan City 333010, Taiwan (R.O.C.) TEL: +886-3-327-0868 FAX: +886-3-327-0855
Test Site No.	Sporton Site No. TH05-HY, CO07-HY, 03CH13-HY

Note: The test site complies with ANSI C63.4 2014 requirement.

FCC designation No.: TW3786



1.4 Applicable Standards

According to the specifications declared by the manufacturer, the EUT must comply with the requirements of the following standards:

- ♦ FCC Part 15 Subpart C §15.247
- ♦ FCC KDB Publication No. 558074 D01 15.247 Meas Guidance v05r02
- ♦ FCC KDB 414788 D01 Radiated Test Site v01r01
- ♦ ANSI C63.10-2013

Remark:

1. All the test items were validated and recorded in accordance with the standards without any modification during the testing.
2. The TAF code is not including all the FCC KDB listed without accreditation.
3. This EUT has also been tested and complied with the requirements of FCC Part 15, Subpart B, recorded in a separate test report.



2 Test Configuration of Equipment Under Test

2.1 Carrier Frequency Channel

Frequency Band	Channel	Freq. (MHz)	Channel	Freq. (MHz)
nRF	0	2402	21	2444
	1	2404	22	2446
	2	2406	23	2448
	3	2408	24	2450
	4	2410	25	2452
	5	2412	26	2454
	6	2414	27	2456
	7	2416	28	2458
	8	2418	29	2460
	9	2420	30	2462
	10	2422	31	2464
	11	2424	32	2466
	12	2426	33	2468
	13	2428	34	2470
	14	2430	35	2472
	15	2432	36	2474
	16	2434	37	2476
	17	2436	38	2478
	18	2438	-	-
	19	2440	-	-
20	2442	-	-	



2.2 Test Mode

- a. The EUT has been associated with peripherals and configuration operated in a manner tended to maximize its emission characteristics in a typical application. Frequency range investigated: conduction emission (150 kHz to 30 MHz), radiation emission (9 kHz to the 10th harmonic of the highest fundamental frequency or to 40 GHz, whichever is lower). For radiated measurement, the measured emission level of the EUT was maximized by rotating the EUT on a turntable, adjusting the orientation of the EUT and EUT antenna in three orthogonal axis (X: flat, Y: portrait, Z: landscape), and adjusting the measurement antenna orientation, following C63.10 exploratory test procedures and only the worst case emissions were reported in this report.
- b. AC power line Conducted Emission was tested under maximum output power.

The following summary table is showing all test modes to demonstrate in compliance with the standard.

Summary table of Test Cases	
Test Item	Data Rate / Modulation
Conducted Test Cases	Mode 1: nRF Tx CH00_2402 MHz_2Mbps Mode 2: nRF Tx CH19_2440 MHz_2Mbps Mode 3: nRF Tx CH38_2478 MHz_2Mbps
Radiated Test Cases	Mode 1: nRF Tx CH00_2402 MHz_2Mbps Mode 2: nRF Tx CH19_2440 MHz_2Mbps Mode 3: nRF Tx CH38_2478 MHz_2Mbps
AC Conducted Emission	Mode 1 :Bluetooth Link + WLAN (2.4GHz) Link + nRF Link + USB Cable (Charging from AC Adapter) for Sample 1 Mode 2 :Bluetooth Link + WLAN (2.4GHz) Link + nRF Link + USB Cable (Charging from AC Adapter) for Sample 2 Mode 3 :Bluetooth Link + WLAN (2.4GHz) Link + nRF Link + USB Cable (Charging from AC Adapter) for Sample 3
Remark:	
<ol style="list-style-type: none"> 1. The worst case of Conducted Emission is mode 1; only the test data of it was reported. 2. For radiation spurious emission, the modulation and the data rate picked for testing are determined by the Max. RF conducted power. 3. For Radiated Test Cases, the tests were performed with Sample 1. 	

2.3 Connection Diagram of Test System

<AC Conducted Emission Mode>

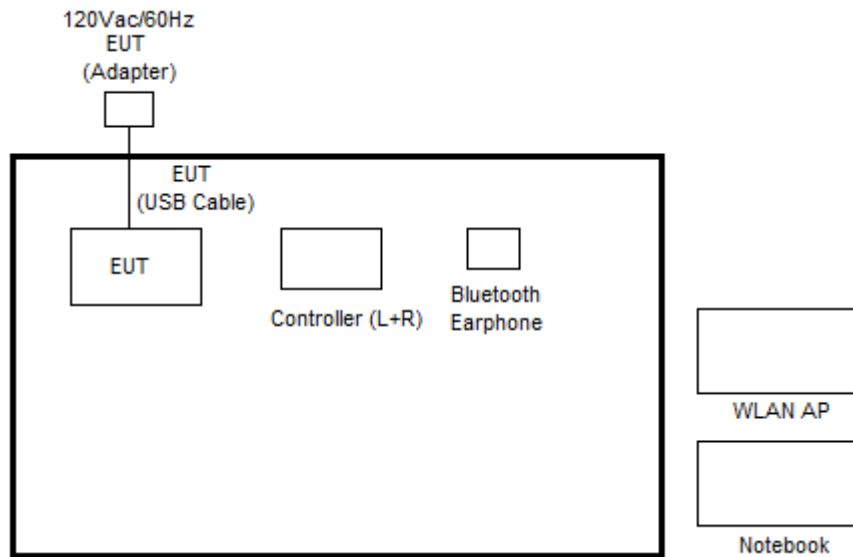

<nRF Tx Mode>

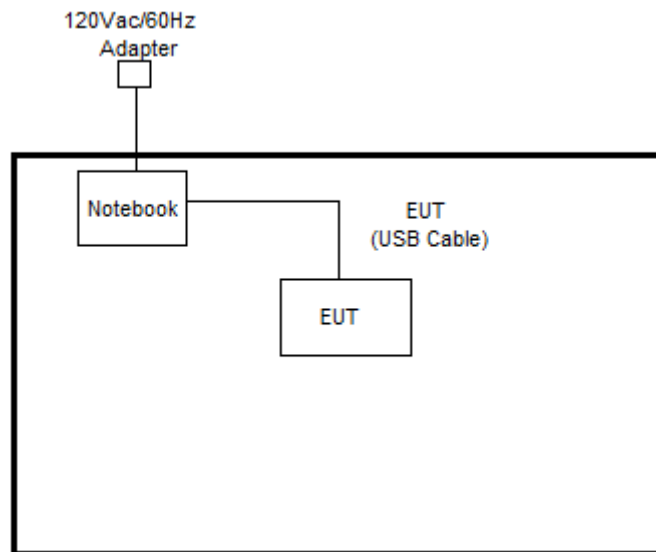



2.4 Support Unit used in test configuration and system

Item	Equipment	Brand Name	Model Name	FCC ID	Data Cable	Power Cord
1.	Bluetooth Earphone	Sony	SBH20	PY7-RD0010	N/A	N/A
2.	WLAN AP	Netgear	RAXE500	PY320300508	N/A	Unshielded, 1.8 m
3.	Controller	Meta	Rubby	N/A	N/A	N/A
4.	Notebook	Dell	Latitude 3420	N/A	N/A	AC I/P: Unshielded, 1.2 m DC O/P: Shielded, 1.8 m

2.5 EUT Operation Test Setup

The RF test items, utility “QRCT Version 4.0.00211.0” was installed in Notebook which was programmed in order to make the EUT get into the engineering modes to provide channel selection, power level, data rate and the application type and for continuous transmitting signals.

2.6 Measurement Results Explanation Example

For all conducted test items:

The offset level is set in the spectrum analyzer to compensate the RF cable loss and attenuator factor between EUT conducted output port and spectrum analyzer. With the offset compensation, the spectrum analyzer reading level is exactly the EUT RF output level.

Example :

The spectrum analyzer offset is derived from RF cable loss and attenuator factor.

Offset = RF cable loss + attenuator factor.

Following shows an offset computation example with cable loss 4.2 dB and 10 dB attenuator.

$$\begin{aligned} \text{Offset(dB)} &= \text{RF cable loss(dB)} + \text{attenuator factor(dB)}. \\ &= 4.2 + 10 = 14.2 \text{ (dB)} \end{aligned}$$

3 Test Result

3.1 6dB and 99% Bandwidth Measurement

3.1.1 Limit of 6dB and 99% Bandwidth

The minimum 6 dB bandwidth shall be at least 500 kHz.

3.1.2 Measuring Instruments

Please refer to the measuring equipment list in this test report.

3.1.3 Test Procedures

1. The testing follows the ANSI C63.10 Section 6.9.3 (OBW) and 11.8.1 (6dB BW).
2. The RF output of EUT is connected to the spectrum analyzer by RF cable and attenuator. The path loss is compensated to the results for each measurement.
3. Set the maximum power setting and enable the EUT to transmit continuously.
4. Make the measurement with the spectrum analyzer's resolution bandwidth (RBW) = 100 kHz. Set the Video bandwidth (VBW) = 300 kHz. In order to make an accurate measurement. The 6dB bandwidth must be greater than 500 kHz.
5. For 99% Bandwidth Measurement, the spectrum analyzer's resolution bandwidth (RBW) is set 1-5% of the emission bandwidth and set the Video bandwidth (VBW) $\geq 3 * RBW$.
6. Measure and record the results in the test report.

3.1.4 Test Setup



3.1.5 Test Result of 6dB Bandwidth

Please refer to Appendix A.

3.1.6 Test Result of 99% Occupied Bandwidth

Please refer to Appendix A.

3.2 Output Power Measurement

3.2.1 Limit of Output Power

For systems using digital modulation in the 2400-2483.5 MHz, the limit for output power is 30 dBm. If transmitting antenna of directional gain greater than 6 dBi is used, the peak output power from the intentional radiator shall be reduced below the above stated value by the amount in dB that the directional gain of the antenna exceeds 6 dBi. In case of point-to-point operation, the limit has to be reduced by 1 dB for every 3 dB that the directional gain of the antenna exceeds 6 dBi.

3.2.2 Measuring Instruments

Please refer to the measuring equipment list in this test report.

3.2.3 Test Procedures

1. For Average Power, the testing follows ANSI C63.10 Section 11.9.2.3.2 Method AVGP-M-G
2. The RF output of EUT is connected to the power meter by RF cable and attenuator.
3. The path loss is compensated to the results for each measurement.
4. Set the maximum power setting and enable the EUT to transmit continuously.
5. Measure the conducted output power and record the results in the test report.

3.2.4 Test Setup

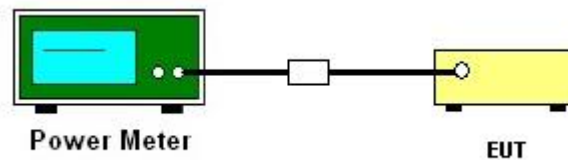

3.2.5 Test Result of Average Output Power

Please refer to Appendix A.

3.3 Power Spectral Density Measurement

3.3.1 Limit of Power Spectral Density

The peak power spectral density shall not be greater than 8 dBm in any 3 kHz band at any time interval of continuous transmission.

3.3.2 Measuring Instruments

Please refer to the measuring equipment list in this test report.

3.3.3 Test Procedures

1. The testing follows the ANSI C63.10 Section 11.10.2 Method PKPSD.
2. The RF output of EUT is connected to the spectrum analyzer by RF cable and attenuator. The path loss is compensated to the results for each measurement.
3. Set the maximum power setting and enable the EUT to transmit continuously.
4. Make the measurement with the spectrum analyzer's resolution bandwidth (RBW) = 3 kHz. Video bandwidth (VBW) = 10 kHz. In order to make an accurate measurement, set the span to 1.5 times DTS Channel Bandwidth. (6 dB BW)
5. Detector = peak, Sweep time = auto couple, Trace mode = max hold, Allow trace to fully stabilize. Use the peak marker function to determine the maximum power level.
6. Measure and record the results in the test report.
7. The Measured power density (dBm)/ 100 kHz is a reference level and is used as 20 dBc down limit line for Conducted Band Edges and Conducted Spurious Emission.

3.3.4 Test Setup



3.3.5 Test Result of Power Spectral Density Plots (100kHz)

Please refer to Appendix A.

3.3.6 Test Result of Power Spectral Density Plots (3kHz)

Please refer to Appendix A.

3.4 Conducted Band Edges and Spurious Emission Measurement

3.4.1 Limit of Conducted Band Edges and Spurious Emission

All harmonics/spurious must be at least 30 dB down from the highest emission level within the authorized band.

3.4.2 Measuring Instruments

Please refer to the measuring equipment list in this test report.

3.4.3 Test Procedure

1. The testing follows the ANSI C63.10 Section 11.11.3 Emission level measurement.
2. The RF output of EUT is connected to the spectrum analyzer by RF cable and attenuator. The path loss is compensated to the results for each measurement.
3. Set the maximum power setting and enable the EUT to transmit continuously.
4. Set RBW = 100 kHz, VBW = 300 kHz, Peak Detector. Unwanted Emissions measured in any 100 kHz bandwidth outside of the authorized frequency band shall be attenuated by at least 20 dB relative to the maximum in-band peak PSD level in 100 kHz when maximum peak conducted output power procedure is used. If the transmitter complies with the conducted power limits based on the use of RMS averaging over a time interval, the attenuation required under this paragraph shall be 30 dB instead of 20 dB.
5. Measure and record the results in the test report.
6. The RF fundamental frequency should be excluded against the limit line in the operating frequency band.

3.4.4 Test Setup



3.4.5 Test Result of Conducted Band Edges Plots

Please refer to Appendix A.

3.4.6 Test Result of Conducted Spurious Emission Plots

Please refer to Appendix A.



3.5 Radiated Band Edges and Spurious Emission Measurement

3.5.1 Limit of Radiated Band Edges and Spurious Emission

In any 100 kHz bandwidth outside the intentional radiator frequency band, all harmonics/spurious must be at least 20 dB below the highest emission level within the authorized band. If the output power of this device is measured by spectrum analyzer, the attenuation under this paragraph shall be 30 dB instead of 20 dB. In addition, radiated emissions which fall in the restricted bands must also comply with the limits as below.

Frequency (MHz)	Field Strength (microvolts/meter)	Measurement Distance (meters)
0.009 – 0.490	2400/F(kHz)	300
0.490 – 1.705	24000/F(kHz)	30
1.705 – 30.0	30	30
30 – 88	100	3
88 – 216	150	3
216 - 960	200	3
Above 960	500	3

3.5.2 Measuring Instruments

Please refer to the measuring equipment list in this test report.



3.5.3 Test Procedures

1. The testing follows the ANSI C63.10 Section 11.12.1 Radiated emission measurements.
2. The EUT is arranged to its worst case and then tune the antenna tower (from 1 m to 4 m) and turntable (from 0 degree to 360 degrees) to find the maximum reading. A pre-amp and a high pass filter are used for the test in order to get better signal level.
3. The EUT is placed on a turntable with 0.8 meter for frequency below 1 GHz and 1.5 meter for frequency above 1 GHz respectively above ground.
4. The EUT is set 3 meters away from the receiving antenna, which is mounted on the top of a variable height antenna tower.
5. Corrected Reading: Antenna Factor + Cable Loss + Read Level - Preamp Factor = Level
6. Radiated testing below 1 GHz is performed by adjusting the antenna tower from 1 m to 4 m and by rotating the turn table from 0 degree to 360 degrees to find the peak maximum hold reading. When there is no suspected emission found and the emission level is with at least 6 dB margin against QP limit line, the position is marked as “-“.
7. Radiated testing above 1 GHz is performed by adjusting the antenna tower from 1 m to 4 m and by rotating the turn table from 0 degree to 360 degrees to find the peak maximum hold reading for scanning all frequencies. When there is no suspected emission found and the harmonic emission level is with at least 6 dB margin against average limit line, the position is marked as “-“.
8. Use the following spectrum analyzer settings:
 - (1) Span shall wide enough to fully capture the emission being measured;
 - (2) Set RBW = 100 kHz for $f < 1$ GHz; VBW \geq RBW; Sweep = auto; Detector function = peak; Trace = max hold;
 - (3) Set RBW = 1 MHz, VBW = 3 MHz for $f \geq 1$ GHz for peak measurement.
For average measurement:
 - VBW = 10 Hz, when duty cycle is no less than 98 percent.
 - VBW $\geq 1/T$, when duty cycle is less than 98 percent where T is the minimum transmission duration over which the transmitter is on and is transmitting at its maximum power control level for the tested mode of operation.

3.5.4 Test Setup

For radiated test below 30MHz

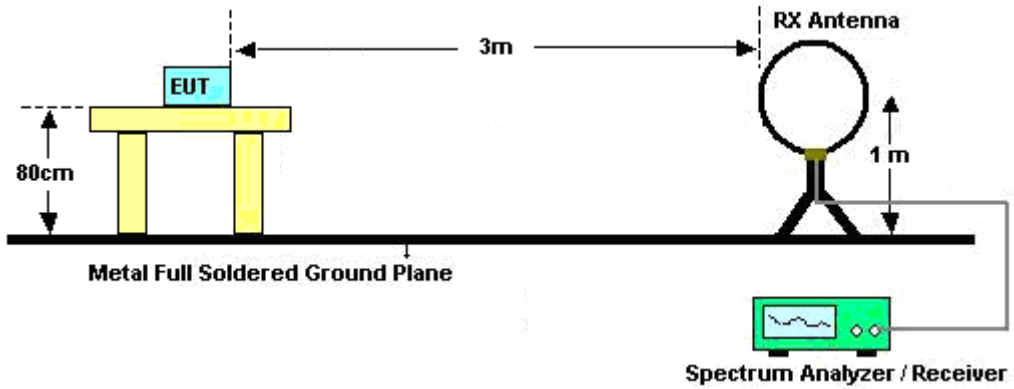

For radiated test from 30MHz to 1GHz

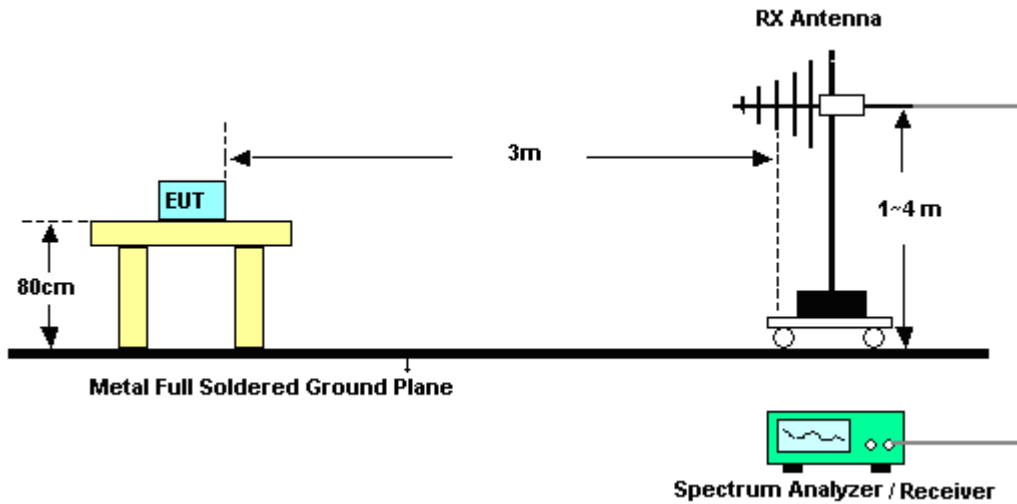

For radiated test from 1GHz to 18GHz

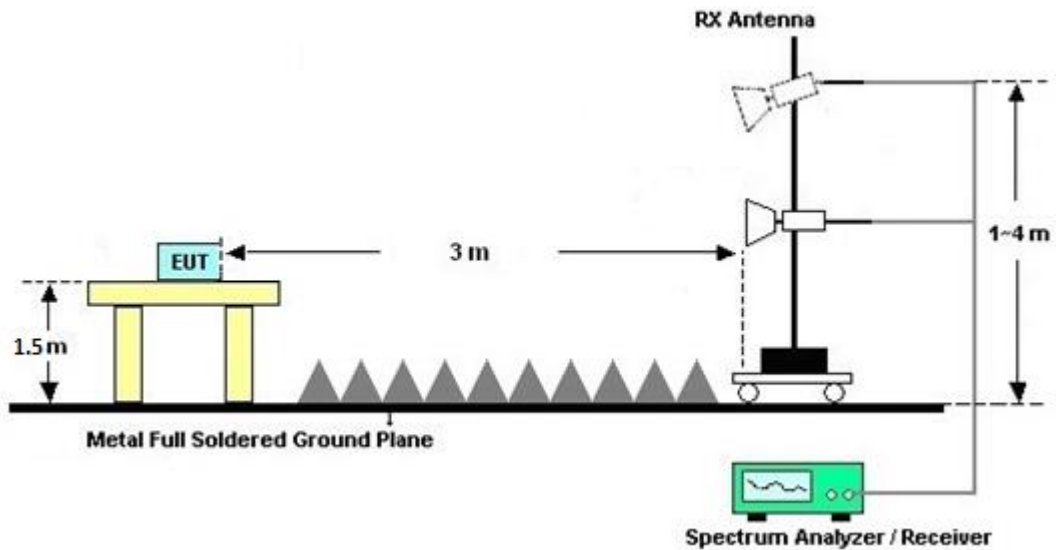

For radiated test above 18GHz

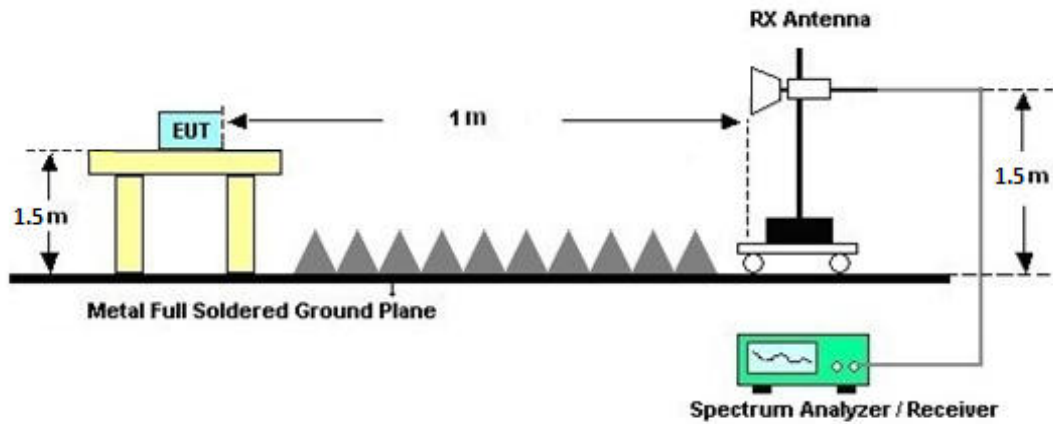

3.5.5 Test Results of Radiated Spurious Emissions (9 kHz ~ 30 MHz)

The low frequency, which starts from 9 kHz to 30 MHz, is pre-scanned and the result which is 20 dB lower than the limit line is not reported.

There is adequate comparison measurement of both open-field test site and alternative test site - semi-Anechoic chamber according to 414788 D01 Radiated Test Site v01r01, and the result comes out very similar.

3.5.6 Test Result of Radiated Spurious at Band Edges

Please refer to Appendix C and D.

3.5.7 Duty Cycle

Please refer to Appendix E.

3.5.8 Test Result of Radiated Spurious Emission (30 MHz ~ 10th Harmonic)

Please refer to Appendix C and D.



3.6 AC Conducted Emission Measurement

3.6.1 Limit of AC Conducted Emission

For equipment that is designed to be connected to the public utility (AC) power line, the radio frequency voltage that is conducted back onto the AC power line on any frequency or frequencies within the band 150 kHz to 30 MHz shall not exceed the limits in the following table.

Frequency of emission (MHz)	Conducted limit (dB μ V)	
	Quasi-peak	Average
0.15-0.5	66 to 56*	56 to 46*
0.5-5	56	46
5-30	60	50

*Decreases with the logarithm of the frequency.

3.6.2 Measuring Instruments

Please refer to the measuring equipment list in this test report.

3.6.3 Test Procedures

1. The EUT is placed 0.4 meter away from the conducting wall of the shielding room, and is kept at least 80 centimeters from any other grounded conducting surface.
2. Connect EUT to the power mains through a line impedance stabilization network (LISN).
3. All the support units are connecting to the other LISN.
4. The LISN provides 50 ohm coupling impedance for the measuring instrument.
5. The FCC states that a 50 ohm, 50 microhenry LISN shall be used.
6. Both Line and Neutral shall be tested in order to find out the maximum conducted emission.
7. The frequency range from 150 kHz to 30 MHz is scanned.
8. Set the test-receiver system to Peak Detect Function and specified bandwidth (IF Bandwidth = 9 kHz) with Maximum Hold Mode. Then measurement is also conducted by Average Detector and Quasi-Peak Detector Function respectively.

3.6.4 Test Setup

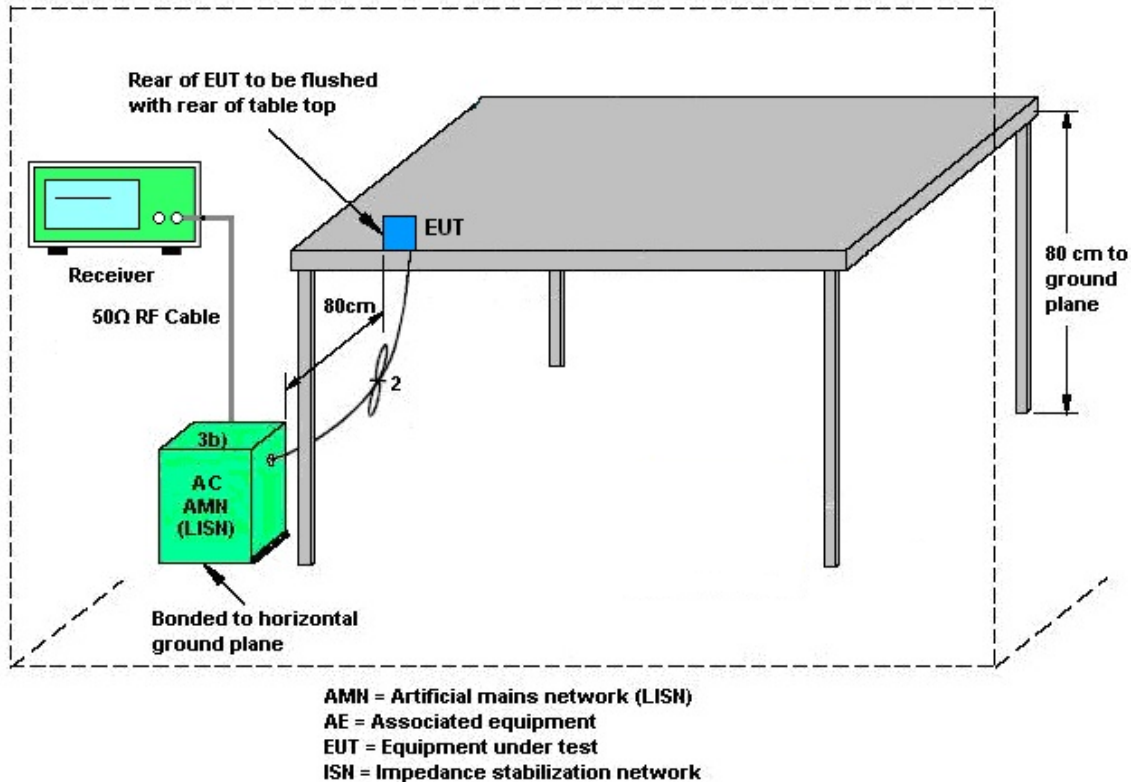

3.6.5 Test Result of AC Conducted Emission

Please refer to Appendix B.



3.7 Antenna Requirements

3.7.1 Standard Applicable

The use of a permanently attached antenna or of an antenna that uses a unique coupling to the intentional radiator shall be considered sufficient to comply with the rule.

3.7.2 Antenna Anti-Replacement Construction

An embedded-in antenna design is used.



4 List of Measuring Equipment

Instrument	Brand Name	Model No.	Serial No.	Characteristics	Calibration Date	Test Date	Due Date	Remark
Loop Antenna	Rohde & Schwarz	HFH2-Z2	100315	9 kHz~30 MHz	Feb. 23, 2024	Apr. 11, 2024~ May 09, 2024	Feb. 22, 2025	Radiation (03CH13-HY)
RF Cable	HUBER + SUHNER	SUCOFLEX 102	803951/2	9k~30M	Mar. 06, 2024	Apr. 11, 2024~ May 09, 2024	Mar. 05, 2025	Radiation (03CH13-HY)
Amplifier	SONOMA	310N	187282	9kHz~1GHz	Dec. 13, 2023	Apr. 11, 2024~ May 09, 2024	Dec. 12, 2024	Radiation (03CH13-HY)
Bilog Antenna	TESEQ	CBL 6111D & 00800N1D01N-06	40103 & 07	30MHz~1GHz	Apr. 23, 2023	Apr. 11, 2024	Apr. 22, 2024	Radiation (03CH13-HY)
Bilog Antenna	TESEQ	CBL 6111D & 00800N1D01N-06	40103 & 07	30MHz~1GHz	Apr. 12, 2024	Apr. 12, 2024~ May 09, 2024	Apr. 11, 2025	Radiation (03CH13-HY)
EMI Test Receiver	Agilent	N9038A(MXE)	MY53290045	20MHz~8.4GHz	Apr. 25, 2023	Apr. 11, 2024~ Apr. 16, 2024	Apr. 24, 2024	Radiation (03CH13-HY)
EMI Test Receiver	Agilent	N9038A(MXE)	MY53290045	20MHz~8.4GHz	Apr. 17, 2024	Apr. 17, 2024~ May 09, 2024	Apr. 16, 2025	Radiation (03CH13-HY)
Horn Antenna	SCHWARZBECK	BBHA 9120 D	9120D-1326	1GHz~18GHz	Aug. 17, 2023	Apr. 11, 2024~ May 09, 2024	Aug. 16, 2024	Radiation (03CH13-HY)
Preamplifier	MITEQ	AMF-7D-00101800- 30-10P	1590074	1GHz~18GHz	May 16, 2023	Apr. 11, 2024~ May 09, 2024	May 15, 2024	Radiation (03CH13-HY)
Preamplifier	EM Electronics	EM01G18G	060803	1GHz~18GHz	Jan. 09, 2024	Apr. 11, 2024~ May 09, 2024	Jan. 08, 2025	Radiation (03CH13-HY)
Preamplifier	EMEC	EM18G40G	060801	18GHz~40GHz	Jun. 27, 2023	Apr. 11, 2024~ May 09, 2024	Jun. 26, 2024	Radiation (03CH13-HY)
SHF-EHF Horn Antenna	SCHWARZBECK	BBHA9170	00993	18GHz-40GHz	Nov. 24, 2023	Apr. 11, 2024~ May 09, 2024	Nov. 23, 2024	Radiation (03CH13-HY)
Spectrum Analyzer	Keysight	N9010B	MY62170337	10Hz~44GHz	Aug. 17, 2023	Apr. 11, 2024~ May 09, 2024	Aug. 16, 2024	Radiation (03CH13-HY)
Filter	Wainwright	WLK10-4630-5093- 11000-40SS	SN1	4.5GHz Low Pass Filter	Sep. 11, 2023	Apr. 11, 2024~ May 09, 2024	Sep. 10, 2024	Radiation (03CH13-HY)
Filter	Wainwright	WHKX8-5872.5-675 0-18000-40ST	SN5	6.75GHz High Pass Filter	Mar. 08, 2024	Apr. 11, 2024~ May 09, 2024	Mar. 07, 2025	Radiation (03CH13-HY)
Filter	Wainwright	WHKX6-7268-9200- 26500-40CD	SN4	9GHz High Pass Filter	May 23, 2023	Apr. 11, 2024~ May 09, 2024	May 22, 2024	Radiation (03CH13-HY)
Filter	Wainwright	WLK4-1000-1530-8 000-40SS	SN4	1.53GHz Low Pass Filter	Jun. 14, 2023	Apr. 11, 2024~ May 09, 2024	Jun. 13, 2024	Radiation (03CH13-HY)
Filter	Wainwright	WHKX12-2700-300 0-18000-60SS	SN2	3GHz High Pass Filter	Jul. 10, 2023	Apr. 11, 2024~ May 09, 2024	Jul. 09, 2024	Radiation (03CH13-HY)
Notch Filter	Wainwright	WRCQV14-6025-64 25-7125-7525-60SS	SN2	N/A	Jan. 05, 2024	Apr. 11, 2024~ May 09, 2024	Jan. 04, 2025	Radiation (03CH13-HY)
Notch Filter	Wainwright	WRCQV14-5425-58 25-6525-6925-60SS	SN1	N/A	Jan. 05, 2024	Apr. 11, 2024~ May 09, 2024	Jan. 04, 2025	Radiation (03CH13-HY)
RF Cable	HUBER + SUHNER	SUCOFLEX 126E	0030/126E	30MHz~18GHz	Feb. 07, 2024	Apr. 11, 2024~ May 09, 2024	Feb. 06, 2025	Radiation (03CH13-HY)
RF Cable	HUBER + SUHNER	SUCOFLEX 102	804011/2, 804012/2	18GHz ~40GHz	Jan. 02, 2024	Apr. 11, 2024~ May 09, 2024	Jan. 01, 2025	Radiation (03CH13-HY)
RF Cable	HUBER + SUHNER	SUCOFLEX 104	804793/4	30MHz~18GHz	Feb. 07, 2024	Apr. 11, 2024~ May 09, 2024	Feb. 06, 2025	Radiation (03CH13-HY)
RF Cable	HUBER + SUHNER	SUCOFLEX 104	MY24961/4	30MHz~18GHz	Feb. 07, 2024	Apr. 11, 2024~ May 09, 2024	Feb. 06, 2025	Radiation (03CH13-HY)
Hygrometer	TECPEL	DTM-303A	TP215159	N/A	Sep. 13, 2023	Apr. 11, 2024~ May 09, 2024	Sep. 12, 2024	Radiation (03CH13-HY)
Controller	EMEC	EM1000	N/A	Control Turn table & Ant Mast	N/A	Apr. 11, 2024~ May 09, 2024	N/A	Radiation (03CH13-HY)
Antenna Mast	EMEC	AM-BS-4500-B	N/A	1m~4m	N/A	Apr. 11, 2024~ May 09, 2024	N/A	Radiation (03CH13-HY)
Turn Table	EMEC	TT2000	N/A	0~360 Degree	N/A	Apr. 11, 2024~ May 09, 2024	N/A	Radiation (03CH13-HY)
Software	Audix	N/A	RK-001124	N/A	N/A	Apr. 11, 2024~ May 09, 2024	N/A	Radiation (03CH13-HY)



Instrument	Brand Name	Model No.	Serial No.	Characteristics	Calibration Date	Test Date	Due Date	Remark
Hygrometer	TECPEL	DTM-303A	TP201996	N/A	Nov. 07, 2023	Apr. 12, 2024~ May 18, 2024	Nov. 06, 2024	Conducted (TH05-HY)
Power Sensor	DARE	RPR3006W	17100015S NO35 (NO:109)	10MHz~6GHz	Jan. 15, 2024	Apr. 12, 2024~ May 18, 2024	Jan. 14, 2025	Conducted (TH05-HY)
Signal Analyzer	Rohde & Schwarz	FSV40	101566	10Hz~40GHz	Aug. 23, 2023	Apr. 12, 2024~ May 18, 2024	Aug. 22, 2024	Conducted (TH05-HY)
AC Power Source	ACPOWER	AFC-11003G	F31704003 3	N/A	N/A	Apr. 25, 2024	N/A	Conduction (CO07-HY)
Software	Rohde & Schwarz	EMC32 V10.30	N/A	N/A	N/A	Apr. 25, 2024	N/A	Conduction (CO07-HY)
Pulse Limiter	SCHWARZB ECK	VTSD 9561-F N	9561-F N00373	9kHz-200MHz	Oct. 20, 2023	Apr. 25, 2024	Oct. 19, 2024	Conduction (CO07-HY)
RF Cable	HUBER + SUHNER	RG 214/U	1358175	9kHz~30MHz	Mar. 14, 2024	Apr. 25, 2024	Mar. 13, 2025	Conduction (CO07-HY)
Two-Line V-Network	TESEQ	NNB 51	45051	N/A	Mar. 10, 2024	Apr. 25, 2024	Mar. 09, 2025	Conduction (CO07-HY)
Four-Line V-Network	TESEQ	NNB 52	36122	N/A	Mar. 07, 2024	Apr. 25, 2024	Mar. 06, 2025	Conduction (CO07-HY)
EMI Test Receiver	Rohde & Schwarz	ESR3	102317	9kHz~3.6GHz	Sep. 20, 2023	Apr. 25, 2024	Sep. 19, 2024	Conduction (CO07-HY)



5 Measurement Uncertainty

Uncertainty of Conducted Emission Measurement (150kHz ~ 30MHz)

Measuring Uncertainty for a Level of Confidence of 95% ($U = 2Uc(y)$)	3.44 dB
---	---------

Uncertainty of Radiated Emission Measurement (30 MHz ~ 1000 MHz)

Measuring Uncertainty for a Level of Confidence of 95% ($U = 2Uc(y)$)	6.5 dB
---	--------

Uncertainty of Radiated Emission Measurement (1000 MHz ~ 6000 MHz)

Measuring Uncertainty for a Level of Confidence of 95% ($U = 2Uc(y)$)	4.2 dB
---	--------

Uncertainty of Radiated Emission Measurement (6000 MHz ~ 18000 MHz)

Measuring Uncertainty for a Level of Confidence of 95% ($U = 2Uc(y)$)	4.6 dB
---	--------

Uncertainty of Radiated Emission Measurement (18000 MHz ~ 40000 MHz)

Measuring Uncertainty for a Level of Confidence of 95% ($U = 2Uc(y)$)	5.3 dB
---	--------

Appendix A. Test Result of Conducted Test Items

Test Engineer:	Hank Hsu	Temperature:	21~25	°C
Test Date:	2024/4/12~2024/5/18	Relative Humidity:	51~54	%

TEST RESULTS DATA
6dB and 99% Occupied Bandwidth

Mod.	Data Rate	NTX	CH.	Freq. (MHz)	99% Occupied BW (MHz)	6dB BW (MHz)	6dB BW Limit (MHz)	Pass/Fail
nRF	2Mbps	1	0	2402	1.998	0.559	0.50	Pass
nRF	2Mbps	1	19	2440	1.998	0.560	0.50	Pass
nRF	2Mbps	1	38	2478	1.998	0.558	0.50	Pass

TEST RESULTS DATA
Average Power Table

Mod.	Data Rate	NTX	CH.	Freq. (MHz)	Average Conducted Power (dBm)	Conducted Power Limit (dBm)	DG (dBi)	EIRP Power (dBm)	EIRP Power Limit (dBm)	Pass /Fail
nRF	2Mbps	1	0	2402	3.80	30.00	4.50	8.30	36.00	Pass
nRF	2Mbps	1	19	2440	4.40	30.00	4.50	8.90	36.00	Pass
nRF	2Mbps	1	38	2478	3.50	30.00	4.50	8.00	36.00	Pass

TEST RESULTS DATA
Peak Power Density

Mod.	Data Rate	NTX	CH.	Freq. (MHz)	Peak PSD (dBm /100kHz)	Peak PSD (dBm /3kHz)	DG (dBi)	Peak PSD Limit (dBm /3kHz)	Pass/Fail
nRF	2Mbps	1	0	2402	3.25	-11.87	4.50	8.00	Pass
nRF	2Mbps	1	19	2440	3.86	-11.16	4.50	8.00	Pass
nRF	2Mbps	1	38	2478	2.98	-11.91	4.50	8.00	Pass

Note: PSD (dBm/ 100kHz) is a reference level used for Conducted Band Edges and Conducted Spurious Emission 30dBc limit.



6dB Bandwidth

<2Mbps>

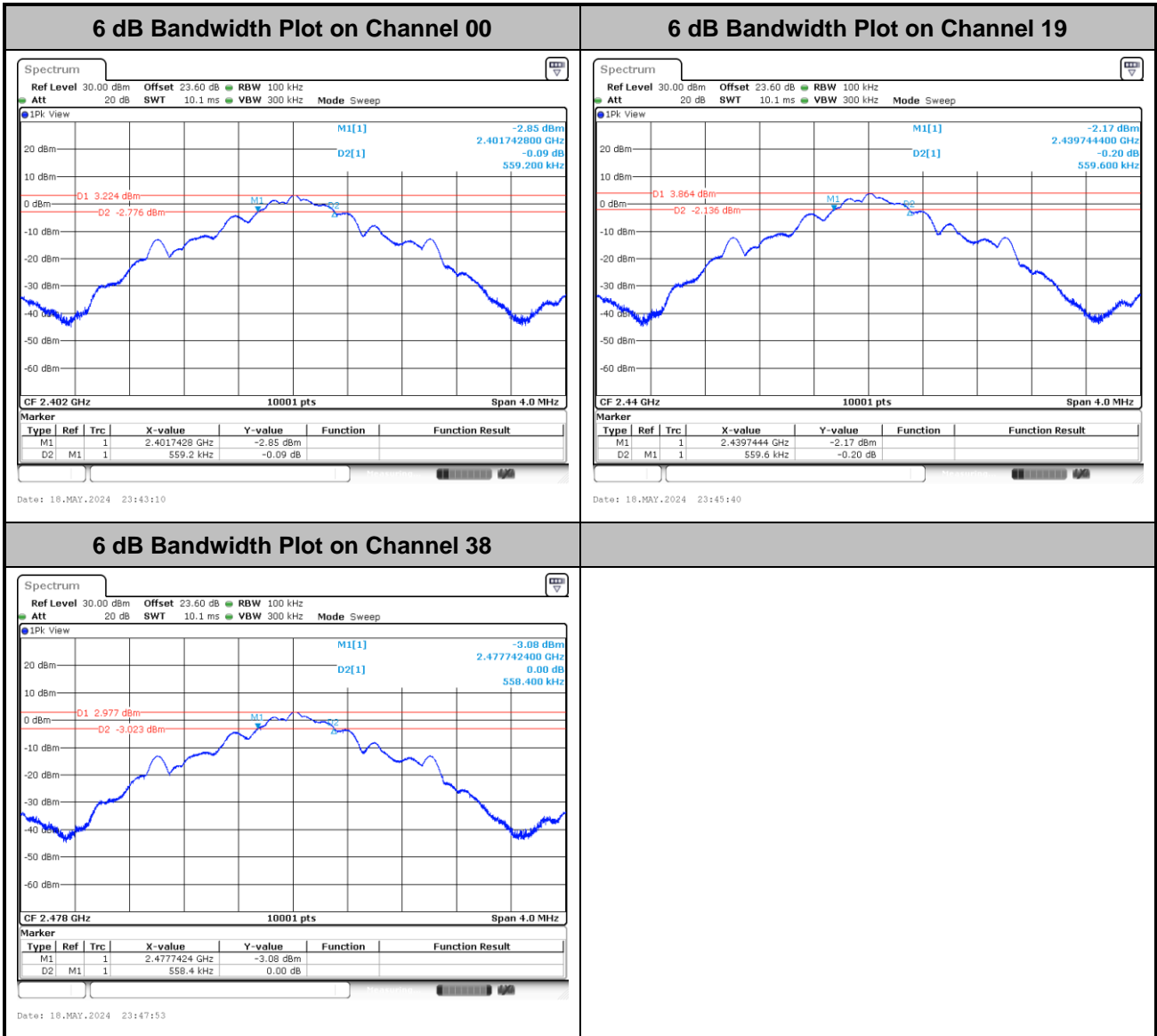



99% Occupied Bandwidth

<2Mbps>

99% Occupied Bandwidth Plot on Channel 00

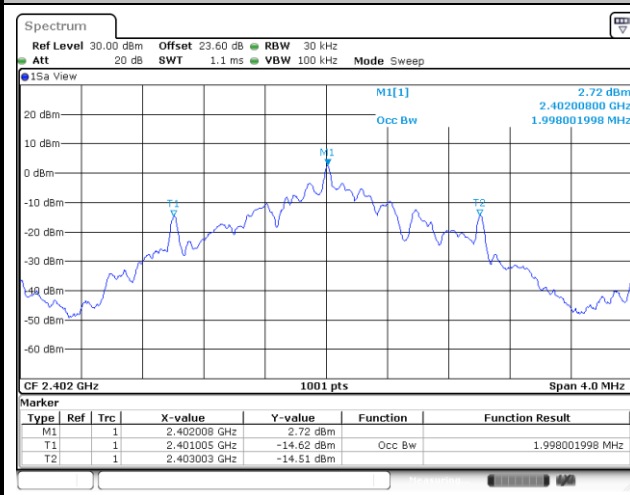

Date: 18.MAY.2024 23:42:58

99% Occupied Bandwidth Plot on Channel 19

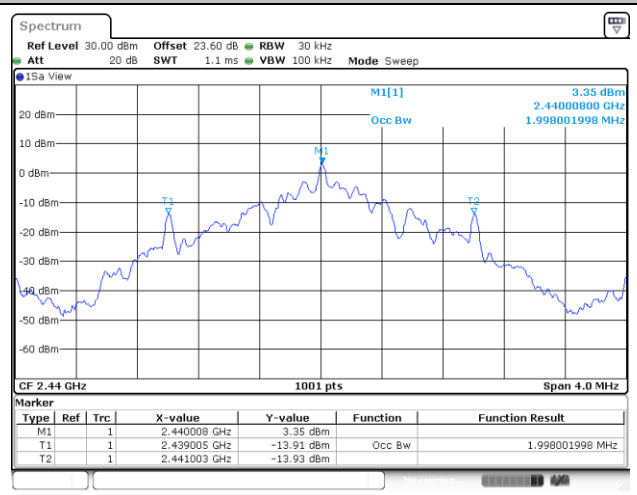

Date: 18.MAY.2024 23:45:28

99% Occupied Bandwidth Plot on Channel 38

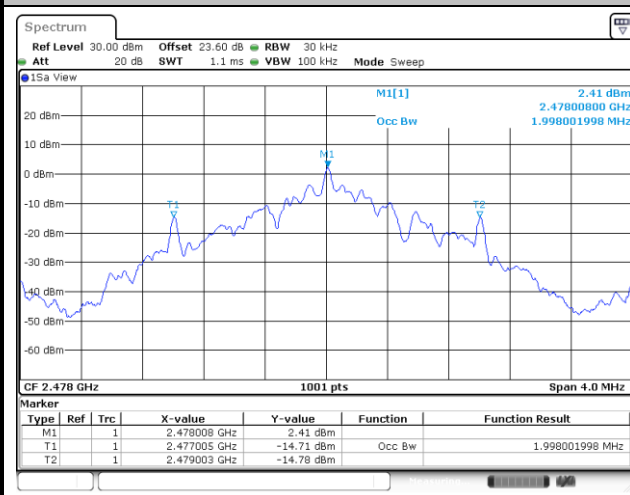

Date: 18.MAY.2024 23:47:38



Power Spectral Density (dBm/3kHz)

<2Mbps>

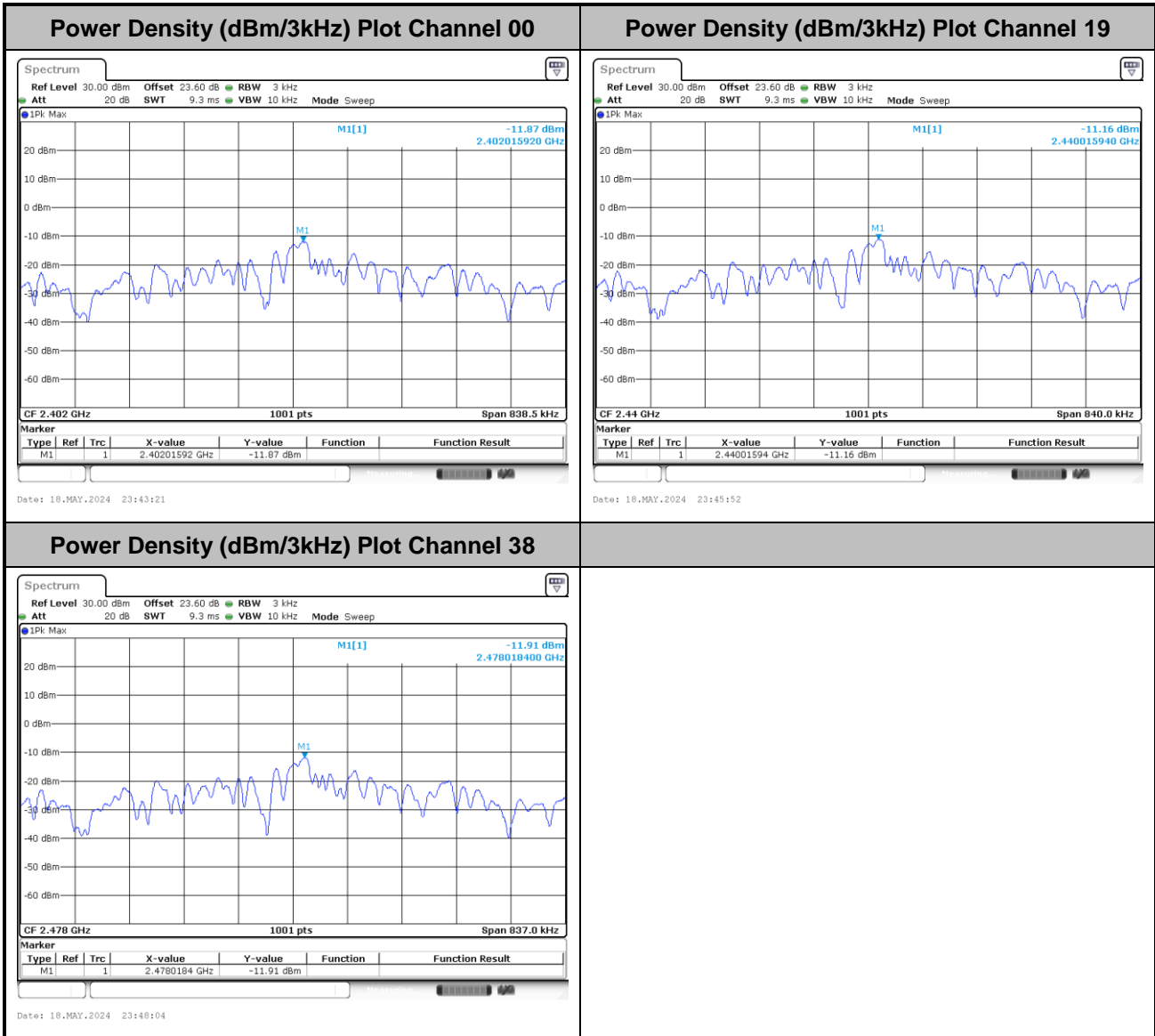



Band Edge and Conducted Spurious Emission

<2Mbps>

Channel 00

100kHz PSD reference Level Plot

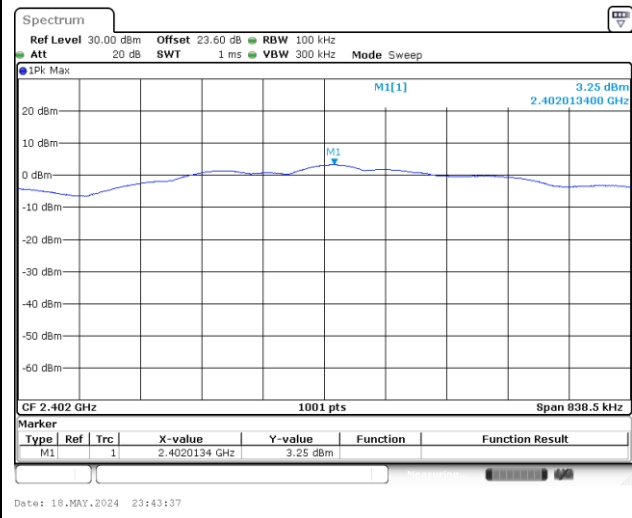

Low Channel Plot

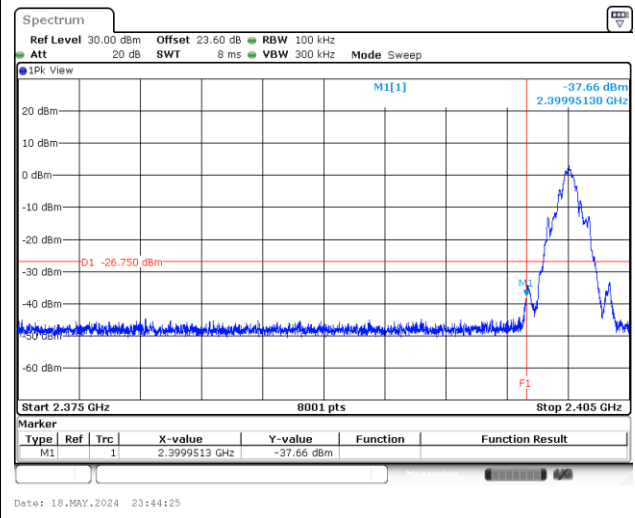

Spurious Emission 30MHz~1GHz Plot

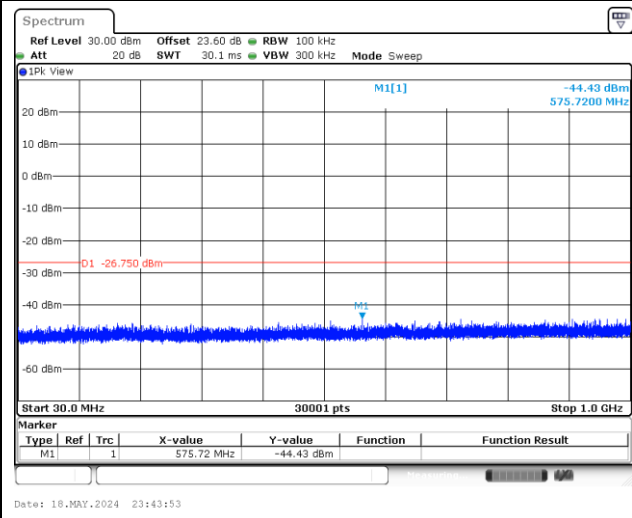

Spurious Emission 1GHz~26.5GHz Plot

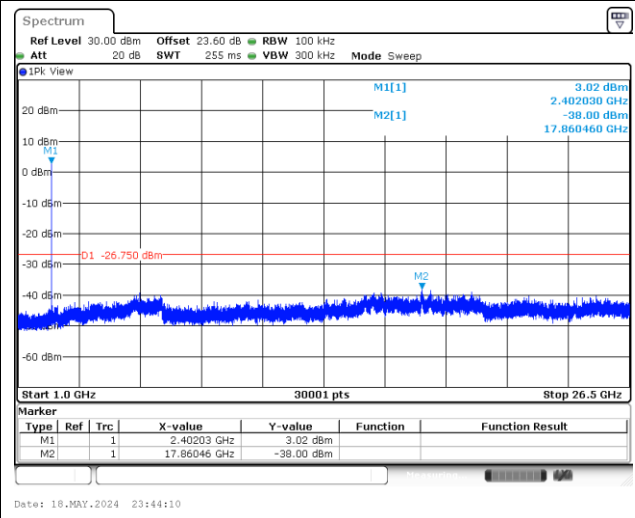



Channel 19

100kHz PSD reference Level Plot

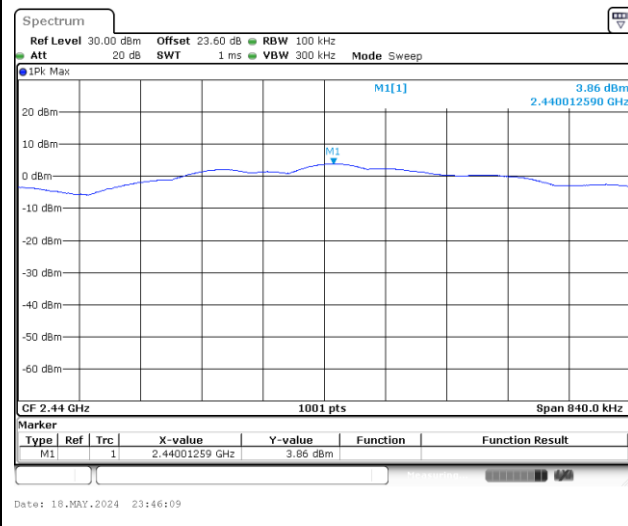

Mid Channel Plot

Spurious Emission 30MHz~1GHz Plot

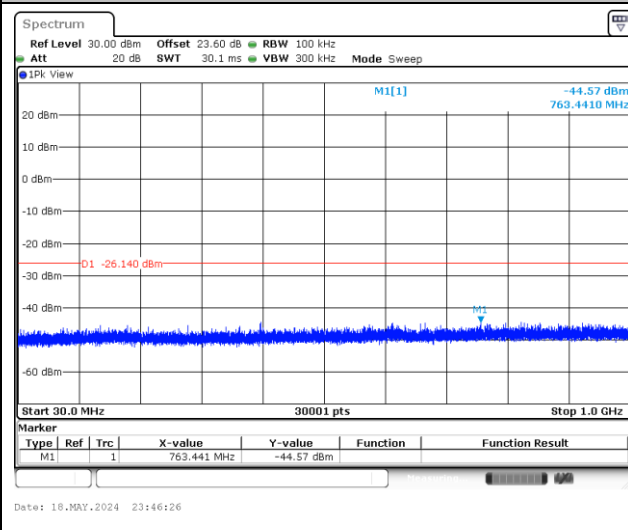

Spurious Emission 1GHz~26.5GHz Plot

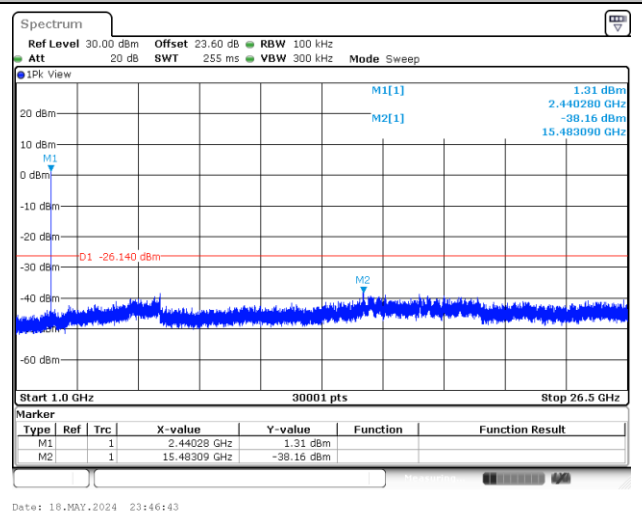



Channel 38

100kHz PSD reference Level Plot

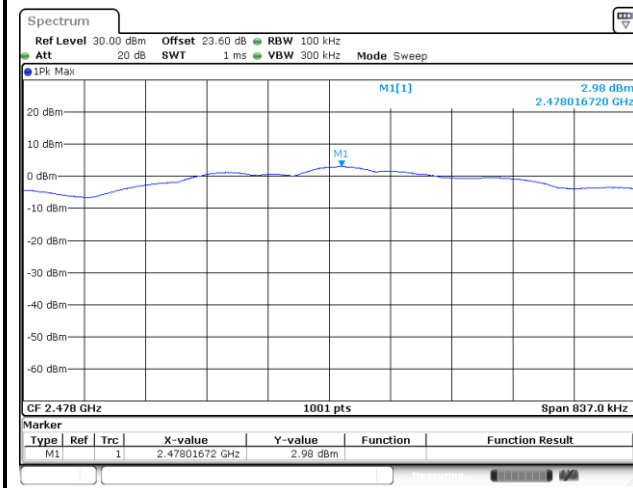

Date: 18.MAY.2024 23:48:21

Low Channel Plot

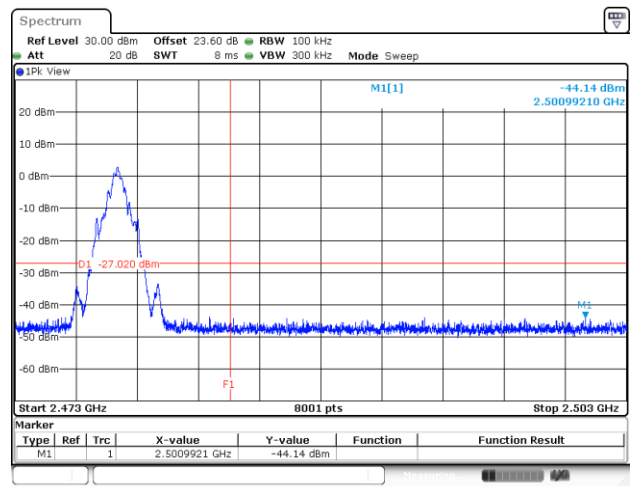

Date: 18.MAY.2024 23:49:15

Spurious Emission 30MHz~1GHz Plot

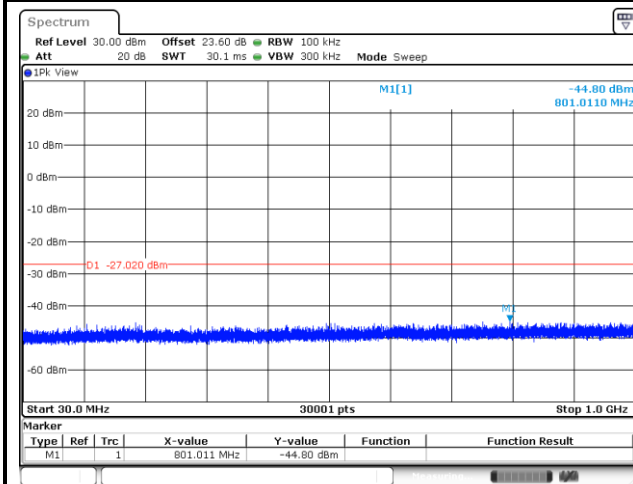

Date: 18.MAY.2024 23:48:38

Spurious Emission 1GHz~26.5GHz Plot

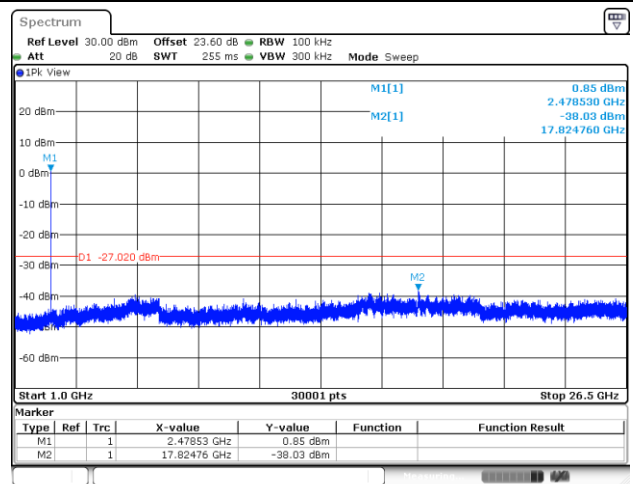

Date: 18.MAY.2024 23:48:56



Appendix B. AC Conducted Emission Test Results

Test Engineer :	Louis Chung	Temperature :	23.4~24.6°C
		Relative Humidity :	48.3~55.7%

EUT Information

Report NO : 413013-01
 Test Mode : Mode 1
 Test Voltage : 120Vac/60Hz
 Phase : Line

Full Spectrum

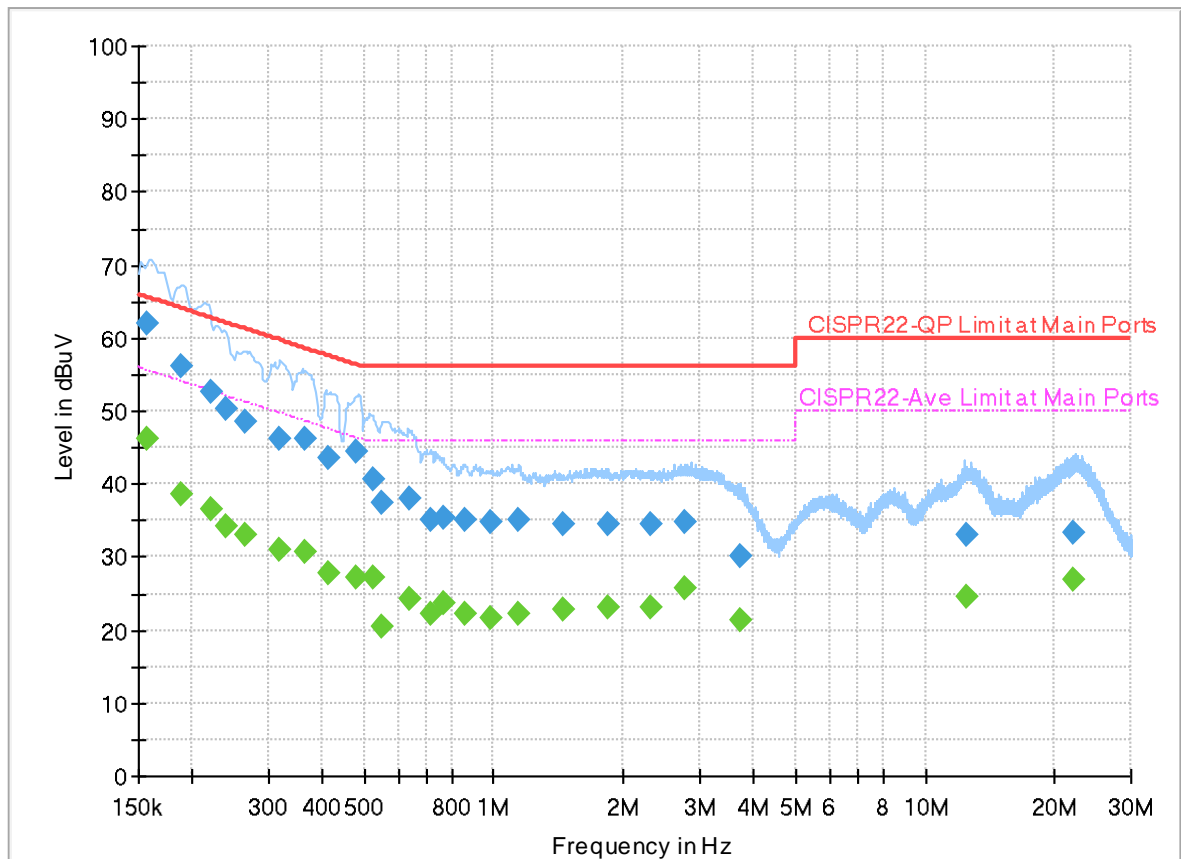

Final_Result

Frequency (MHz)	QuasiPeak (dBuV)	CAverage (dBuV)	Limit (dBuV)	Margin (dB)	Line	Filter	Corr. (dB)
0.156750	---	46.22	55.63	9.41	L1	OFF	19.9
0.156750	62.13	---	65.63	3.50	L1	OFF	19.9
0.187350	---	38.54	54.15	15.61	L1	OFF	19.9
0.187350	56.01	---	64.15	8.14	L1	OFF	19.9
0.220380	---	36.61	52.81	16.20	L1	OFF	19.9
0.220380	52.66	---	62.81	10.15	L1	OFF	19.9
0.238110	---	34.26	52.16	17.90	L1	OFF	19.9
0.238110	50.25	---	62.16	11.91	L1	OFF	19.9
0.265920	---	33.16	51.24	18.08	L1	OFF	19.9
0.265920	48.45	---	61.24	12.79	L1	OFF	19.9
0.319920	---	31.03	49.71	18.68	L1	OFF	19.9
0.319920	46.06	---	59.71	13.65	L1	OFF	19.9
0.365460	---	30.72	48.60	17.88	L1	OFF	19.9
0.365460	46.10	---	58.60	12.50	L1	OFF	19.9
0.414600	---	27.86	47.56	19.70	L1	OFF	19.9
0.414600	43.62	---	57.56	13.94	L1	OFF	19.9
0.477510	---	27.29	46.38	19.09	L1	OFF	19.9
0.477510	44.35	---	56.38	12.03	L1	OFF	19.9
0.523500	---	27.16	46.00	18.84	L1	OFF	19.9

0.523500	40.61	---	56.00	15.39	L1	OFF	19.9
0.552750	---	20.38	46.00	25.62	L1	OFF	19.9
0.552750	37.37	---	56.00	18.63	L1	OFF	19.9
0.634560	---	24.28	46.00	21.72	L1	OFF	19.9
0.634560	37.92	---	56.00	18.08	L1	OFF	19.9
0.711330	---	22.28	46.00	23.72	L1	OFF	19.9
0.711330	35.02	---	56.00	20.98	L1	OFF	19.9
0.763620	---	23.80	46.00	22.20	L1	OFF	19.9
0.763620	35.34	---	56.00	20.66	L1	OFF	19.9
0.854970	---	22.35	46.00	23.65	L1	OFF	19.9
0.854970	35.15	---	56.00	20.85	L1	OFF	19.9
0.985740	---	21.70	46.00	24.30	L1	OFF	19.9
0.985740	34.68	---	56.00	21.32	L1	OFF	19.9
1.142700	---	22.31	46.00	23.69	L1	OFF	19.9
1.142700	35.00	---	56.00	21.00	L1	OFF	19.9
1.442490	---	22.77	46.00	23.23	L1	OFF	19.9
1.442490	34.63	---	56.00	21.37	L1	OFF	19.9
1.829310	---	23.02	46.00	22.98	L1	OFF	19.9
1.829310	34.36	---	56.00	21.64	L1	OFF	19.9
2.323500	---	23.07	46.00	22.93	L1	OFF	20.0
2.323500	34.51	---	56.00	21.49	L1	OFF	20.0
2.760090	---	25.87	46.00	20.13	L1	OFF	20.0
2.760090	34.68	---	56.00	21.32	L1	OFF	20.0
3.745140	---	21.46	46.00	24.54	L1	OFF	20.0
3.745140	30.21	---	56.00	25.79	L1	OFF	20.0
12.518250	---	24.53	50.00	25.47	L1	OFF	20.1
12.518250	33.00	---	60.00	27.00	L1	OFF	20.1
22.051500	---	26.79	50.00	23.21	L1	OFF	20.1
22.051500	33.42	---	60.00	26.58	L1	OFF	20.1

EUT Information

Report NO : 413013-01
 Test Mode : Mode 1
 Test Voltage : 120Vac/60Hz
 Phase : Neutral

Full Spectrum

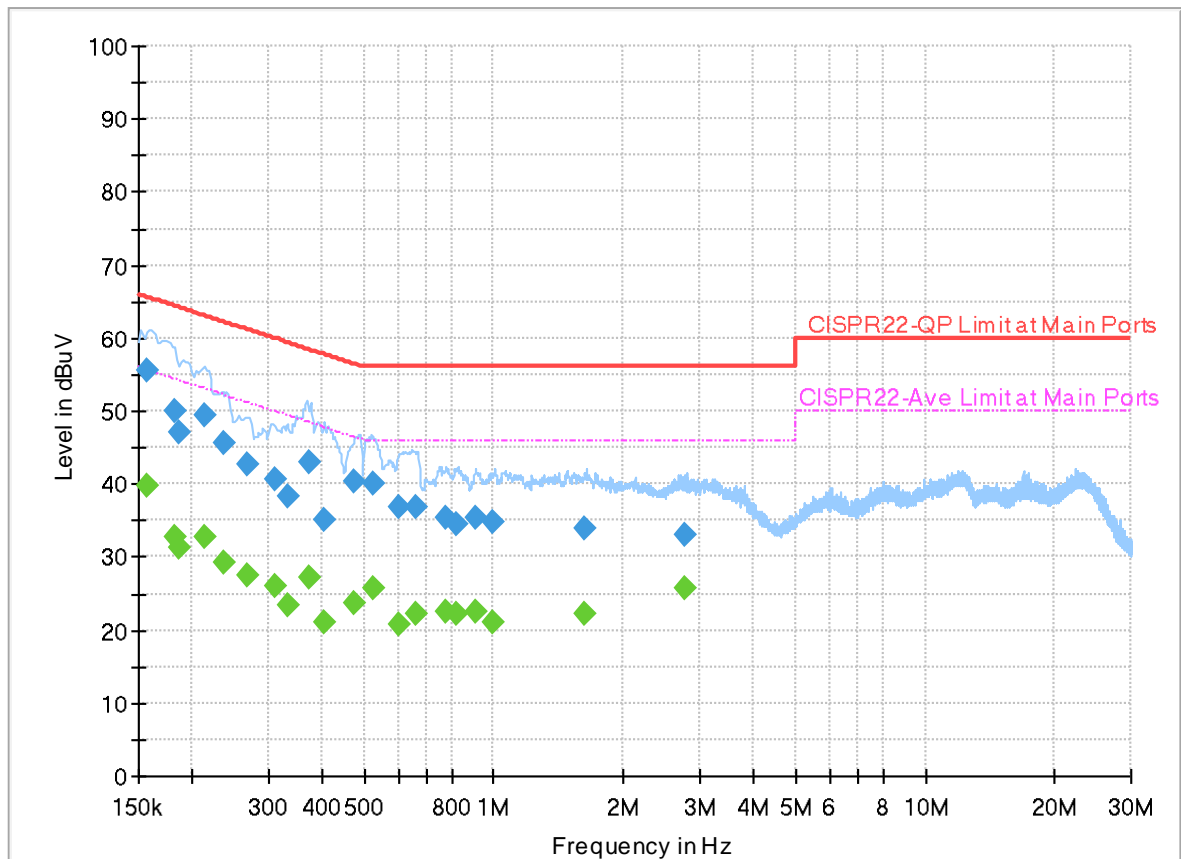

Final_Result

Frequency (MHz)	QuasiPeak (dBuV)	CAverage (dBuV)	Limit (dBuV)	Margin (dB)	Line	Filter	Corr. (dB)
0.156750	---	39.85	55.63	15.78	N	OFF	19.9
0.156750	55.65	---	65.63	9.98	N	OFF	19.9
0.181500	---	32.86	54.42	21.56	N	OFF	19.9
0.181500	50.00	---	64.42	14.42	N	OFF	19.9
0.186900	---	31.24	54.17	22.93	N	OFF	19.9
0.186900	47.11	---	64.17	17.06	N	OFF	19.9
0.214620	---	32.71	53.03	20.32	N	OFF	19.9
0.214620	49.31	---	63.03	13.72	N	OFF	19.9
0.235500	---	29.20	52.25	23.05	N	OFF	19.9
0.235500	45.58	---	62.25	16.67	N	OFF	19.9
0.267900	---	27.57	51.18	23.61	N	OFF	19.9
0.267900	42.70	---	61.18	18.48	N	OFF	19.9
0.312000	---	26.03	49.92	23.89	N	OFF	19.9
0.312000	40.71	---	59.92	19.21	N	OFF	19.9
0.332430	---	23.31	49.39	26.08	N	OFF	19.9
0.332430	38.25	---	59.39	21.14	N	OFF	19.9
0.375000	---	27.30	48.39	21.09	N	OFF	19.9
0.375000	43.04	---	58.39	15.35	N	OFF	19.9
0.402000	---	21.03	47.81	26.78	N	OFF	19.9

0.402000	35.18	---	57.81	22.63	N	OFF	19.9
0.474630	---	23.73	46.43	22.70	N	OFF	19.9
0.474630	40.28	---	56.43	16.15	N	OFF	19.9
0.526650	---	25.59	46.00	20.41	N	OFF	19.9
0.526650	40.07	---	56.00	15.93	N	OFF	19.9
0.604500	---	20.62	46.00	25.38	N	OFF	19.9
0.604500	36.77	---	56.00	19.23	N	OFF	19.9
0.658500	---	22.13	46.00	23.87	N	OFF	19.9
0.658500	36.84	---	56.00	19.16	N	OFF	19.9
0.771720	---	22.50	46.00	23.50	N	OFF	19.9
0.771720	35.42	---	56.00	20.58	N	OFF	19.9
0.820500	---	22.16	46.00	23.84	N	OFF	19.9
0.820500	34.59	---	56.00	21.41	N	OFF	19.9
0.912750	---	22.65	46.00	23.35	N	OFF	19.9
0.912750	35.30	---	56.00	20.70	N	OFF	19.9
0.998880	---	20.94	46.00	25.06	N	OFF	19.9
0.998880	34.86	---	56.00	21.14	N	OFF	19.9
1.627350	---	22.21	46.00	23.79	N	OFF	19.9
1.627350	33.98	---	56.00	22.02	N	OFF	19.9
2.767110	---	25.66	46.00	20.34	N	OFF	20.0
2.767110	33.06	---	56.00	22.94	N	OFF	20.0



Appendix C. Radiated Spurious Emission

Test Engineer :	Jacky Hung, Mancy Chou and Rain Lee	Temperature :	20~26°C
		Relative Humidity :	40~65%

2.4GHz 2400~2483.5MHz

nRF (Band Edge @ 3m)

nRF	Note	Frequency	Level	Margin	Limit	Read	Antenna	Path	Preamp	Ant	Table	Peak	Pol.	
		(MHz)	(dBμV/m)	(dB)	(dBμV/m)	(dBμV)	(dB/m)	(dB)	(dB)	(cm)	(deg)	(P/A)	(H/V)	
nRF CH 00 2402MHz		2385.6	49.05	-24.95	74	44.05	27.46	14.62	37.08	107	335	P	H	
		2388.75	40.76	-13.24	54	35.73	27.49	14.62	37.08	107	335	A	H	
	*	2402	103.65	-	-	98.6	27.5	14.63	37.08	107	335	P	H	
	*	2402	103.07	-	-	98.02	27.5	14.63	37.08	107	335	A	H	
													H	
													H	
			2320.185	48.75	-25.25	74	44.09	27.2	14.55	37.09	173	10	P	V
			2356.41	40.86	-13.14	54	36.06	27.3	14.59	37.09	173	10	A	V
	*		2402	93.57	-	-	88.52	27.5	14.63	37.08	173	10	P	V
	*		2402	92.95	-	-	87.9	27.5	14.63	37.08	173	10	A	V
														V
														V
nRF CH 19 2440MHz		2310.42	48.04	-25.96	74	43.39	27.2	14.54	37.09	109	335	P	H	
		2383.22	41	-13	54	36.04	27.43	14.61	37.08	109	335	A	H	
	*	2440	103.3	-	-	98.11	27.6	14.67	37.08	109	335	P	H	
	*	2440	102.77	-	-	97.58	27.6	14.67	37.08	109	335	A	H	
			2483.55	48.44	-25.56	74	42.99	27.8	14.72	37.07	109	335	P	H
			2485.58	41.79	-12.21	54	36.34	27.8	14.72	37.07	109	335	A	H
			2319.1	48.24	-25.76	74	43.58	27.2	14.55	37.09	152	8	P	V
			2382.94	40.96	-13.04	54	36	27.43	14.61	37.08	152	8	A	V
	*		2440	94.03	-	-	88.84	27.6	14.67	37.08	152	8	P	V
	*		2440	93.45	-	-	88.26	27.6	14.67	37.08	152	8	A	V
			2484.11	48.94	-25.06	74	43.49	27.8	14.72	37.07	152	8	P	V
			2484.81	41.28	-12.72	54	35.83	27.8	14.72	37.07	152	8	A	V



nRF CH 38 2478MHz	*	2478	101.04	-	-	95.61	27.78	14.72	37.07	109	338	P	H
	*	2478	100.53	-	-	95.1	27.78	14.72	37.07	109	338	A	H
		2484.36	52.68	-21.32	74	47.23	27.8	14.72	37.07	109	338	P	H
		2483.52	45.23	-8.77	54	39.78	27.8	14.72	37.07	109	338	A	H
													H
													H
	*	2478	91.27	-	-	85.84	27.78	14.72	37.07	259	11	P	V
	*	2478	90.68	-	-	85.25	27.78	14.72	37.07	259	11	A	V
		2491.4	50.05	-23.95	74	44.59	27.8	14.73	37.07	259	11	P	V
		2483.92	42.12	-11.88	54	36.67	27.8	14.72	37.07	259	11	A	V
													V
													V
Remark	1. No other spurious found. 2. All results are PASS against Peak and Average limit line.												



2.4GHz 2400~2483.5MHz
nRF (Harmonic @ 3m)

nRF	Note	Frequency (MHz)	Level (dBμV/m)	Margin (dB)	Limit Line (dBμV/m)	Read Level (dBμV)	Antenna Factor (dB/m)	Path Loss (dB)	Preamp Factor (dB)	Ant Pos (cm)	Table Pos (deg)	Peak Avg. (P/A)	Pol. (H/V)
nRF CH 00 2402MHz		4804	40.05	-33.95	74	57.84	32.32	7.29	57.4	-	-	P	H
													H
													H
													H
													H
													H
													H
													H
													H
													H
													H
													H
													H
													H
													H
													H
													H
													H
													H
			4804	40.19	-33.81	74	57.98	32.32	7.29	57.4	-	-	P
													V
													V
													V
													V
													V
													V
													V
													V
													V
													V
													V
													V
													V
													V
													V



nRF	Note	Frequency (MHz)	Level (dBμV/m)	Margin (dB)	Limit Line (dBμV/m)	Read Level (dBμV)	Antenna Factor (dB/m)	Path Loss (dB)	Preamp Factor (dB)	Ant Pos (cm)	Table Pos (deg)	Peak Avg. (P/A)	Pol. (H/V)
nRF CH 19 2440MHz		4880	40.62	-33.38	74	57.61	32.66	7.53	57.18	-	-	P	H
		7320	45.87	-28.13	74	56.31	36.92	9.48	56.84	-	-	P	H
													H
													H
													H
													H
													H
													H
													H
													H
													H
													H
													H
													H
													H
													H
													H
													H
													H
			4880	40.23	-33.77	74	57.22	32.66	7.53	57.18	-	-	P
		7320	45.68	-28.32	74	56.12	36.92	9.48	56.84	-	-	P	V
													V
													V
													V
													V
													V
													V
													V
													V
													V
													V
													V
													V
													V
													V
													V



nRF	Note	Frequency (MHz)	Level (dBµV/m)	Margin (dB)	Limit Line (dBµV/m)	Read Level (dBµV)	Antenna Factor (dB/m)	Path Loss (dB)	Preamp Factor (dB)	Ant Pos (cm)	Table Pos (deg)	Peak Avg. (P/A)	Pol. (H/V)
nRF CH 38 2478MHz		4956	41.13	-32.87	74	57.31	33.04	7.75	56.97	-	-	P	H
		7434	44.5	-29.5	74	55.65	36.43	9.46	57.04	-	-	P	H
													H
													H
													H
													H
													H
													H
													H
													H
													H
													H
													H
													H
													H
													H
													H
													H
													H
			4956	41.58	-32.42	74	57.76	33.04	7.75	56.97	-	-	P
		7434	44.04	-29.96	74	55.19	36.43	9.46	57.04	-	-	P	V
													V
													V
													V
													V
													V
													V
													V
													V
													V
													V
													V
													V
													V
Remark	<ol style="list-style-type: none"> No other spurious found. All results are PASS against Peak and Average limit line. The emission position marked as "-" means no suspected emission found with sufficient margin against limit line or noise floor only. 												



Emission above 18GHz

2.4GHz nRF (SHF)

nRF	Note	Frequency	Level	Margin	Limit	Read	Antenna	Path	Preamp	Ant	Table	Peak	Pol.
		(MHz)	(dBμV/m)	(dB)	(dBμV/m)	(dBμV)	(dB/m)	(dB)	(dB)	(cm)	(deg)	(P/A)	(H/V)
2.4GHz nRF SHF		24062	40.85	-33.15	74	58.67	38.65	6.92	53.85	-	-	P	H
													H
													H
													H
													H
													H
													H
													H
													H
													H
													H
													H
													H
													H
													H
													H
													H
													H
													H
			23957	41.98	-32.02	74	59.86	38.7	6.89	53.93	-	-	P
													V
													V
													V
													V
													V
													V
													V
													V
													V
													V
													V
													V
													V

Remark

- No other spurious found.
- All results are PASS against limit line.
- The emission position marked as "-" means no suspected emission found with sufficient margin against limit line or noise floor only.



Note symbol

*	Fundamental Frequency which can be ignored. However, the level of any unwanted emissions shall not exceed the level of the fundamental frequency.
!	Test result is Margin line.
P/A	Peak or Average
H/V	Horizontal or Vertical



A calculation example for radiated spurious emission is shown as below:

nRF	Note	Frequency	Level	Margin	Limit	Read	Antenna	Path	Preamp	Ant	Table	Peak	Pol.
		(MHz)	(dBμV/m)	(dB)	(dBμV/m)	(dBμV)	(dB/m)	(dB)	(dB)	(cm)	(deg)	(P/A)	(H/V)
nRF		2390	55.45	-18.55	74	54.51	32.22	4.58	35.86	103	308	P	H
CH 00		2390	43.54	-10.46	54	42.6	32.22	4.58	35.86	103	308	A	H
2402MHz													

1. Path Loss(dB) = Cable loss(dB) + Filter loss(dB) + Attenuator loss(dB)
2. Level(dBμV/m) =
Antenna Factor(dB/m) + Path Loss(dB) + Read Level(dBμV) - Preamp Factor(dB)
3. Margin (dB) = Level(dBμV/m) – Limit Line(dBμV/m)

For Peak Limit @ 2390MHz:

1. Level(dBμV/m)
= Antenna Factor(dB/m) + Path Loss(dB) + Read Level(dBμV) - Preamp Factor(dB)
= 32.22(dB/m) + 4.58(dB) + 54.51(dBμV) – 35.86 (dB)
= 55.45 (dBμV/m)
2. Margin (dB)
= Level(dBμV/m) – Limit Line(dBμV/m)
= 55.45(dBμV/m) – 74(dBμV/m)
= -18.55(dB)

For Average Limit @ 2390MHz:

1. Level(dBμV/m)
= Antenna Factor(dB/m) + Path Loss(dB) + Read Level(dBμV) - Preamp Factor(dB)
= 32.22(dB/m) + 4.58(dB) + 42.6(dBμV) – 35.86 (dB)
= 43.54 (dBμV/m)
2. Margin (dB)
= Level(dBμV/m) – Limit Line(dBμV/m)
= 43.54(dBμV/m) – 54(dBμV/m)
= -10.46(dB)

Both peak and average measured complies with the limit line, so test result is “PASS”.



Appendix D. Radiated Spurious Emission Plots

Test Engineer :	Jacky Hung, Mancy Chou and Rain Lee	Temperature :	20~26°C
		Relative Humidity :	40~65%

Note symbol

-L	Low channel location
-R	High channel location



2.4GHz 2400~2483.5MHz

nRF (Band Edge @ 3m)

nRF	2.4GHz 2400~2483.5MHz Band Edge @ 3m	
nRF CH00 2402MHz		
Horizontal		Fundamental
Peak	<p>Date: 2024-04-22</p> <p>Site : 03CH13-HY Condition : PEAK_BE_74 3m HORN_91200_1326 HORIZONTAL : RBW:1000.000kHz VBW:3000.000kHz SWT:Auto</p>	<p>Date: 2024-04-22</p> <p>Site : 03CH13-HY Condition : PEAK_74 3m HORN_91200_1326 HORIZONTAL : RBW:1000.000kHz VBW:3000.000kHz SWT:Auto</p>
Avg.	<p>Date: 2024-04-22</p> <p>Site : 03CH13-HY Condition : AV6_BE_54 3m HORN_91200_1326 HORIZONTAL : RBW:1000.000kHz VBW:10.000kHz SWT:Auto</p>	<p>Date: 2024-04-22</p> <p>Site : 03CH13-HY Condition : AV6_54 3m HORN_91200_1326 HORIZONTAL : RBW:1000.000kHz VBW:10.000kHz SWT:Auto</p>

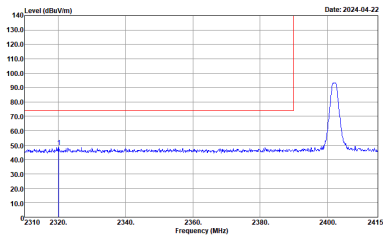
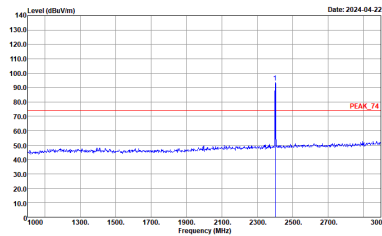
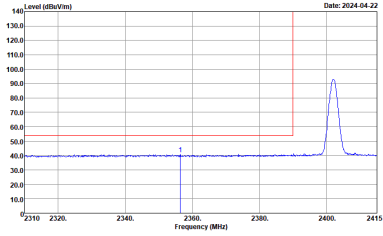
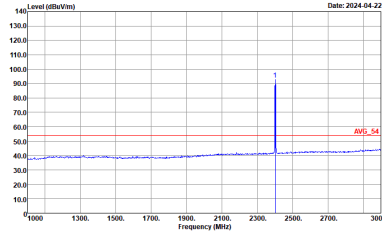

nRF	2.4GHz 2400~2483.5MHz Band Edge @ 3m	
	nRF CH00 2402MHz	
	Vertical	Fundamental
Peak	 <p>Level (dBm/100kHz) vs Frequency (MHz) plot showing a peak at 2402 MHz. The y-axis ranges from 10.0 to 140.0 dBm/100kHz, and the x-axis ranges from 2310 to 2415 MHz. A red line indicates the peak level at approximately 100 dBm/100kHz.</p> <p>Site : 03CH13-HY Condition : PEAK_BE_74 3m HORN_91200_1326 VERTICAL : RBW:1000.000KHz VBW:3000.000KHz SWT:Auto</p>	 <p>Level (dBm/100kHz) vs Frequency (MHz) plot showing a peak at 2402 MHz. The y-axis ranges from 10.0 to 140.0 dBm/100kHz, and the x-axis ranges from 1000 to 3000 MHz. A red line indicates the peak level at approximately 75 dBm/100kHz.</p> <p>Site : 03CH13-HY Condition : PEAK_74 3m HORN_91200_1326 VERTICAL : RBW:1000.000KHz VBW:3000.000KHz SWT:Auto</p>
Avg.	 <p>Level (dBm/100kHz) vs Frequency (MHz) plot showing a peak at 2402 MHz. The y-axis ranges from 10.0 to 140.0 dBm/100kHz, and the x-axis ranges from 2310 to 2415 MHz. A red line indicates the average level at approximately 55 dBm/100kHz.</p> <p>Site : 03CH13-HY Condition : AV6_BE_54 3m HORN_91200_1326 VERTICAL : RBW:1000.000KHz VBW:10.000KHz SWT:Auto</p>	 <p>Level (dBm/100kHz) vs Frequency (MHz) plot showing a peak at 2402 MHz. The y-axis ranges from 10.0 to 140.0 dBm/100kHz, and the x-axis ranges from 1000 to 3000 MHz. A red line indicates the average level at approximately 55 dBm/100kHz.</p> <p>Site : 03CH13-HY Condition : AV6_54 3m HORN_91200_1326 VERTICAL : RBW:1000.000KHz VBW:10.000KHz SWT:Auto</p>

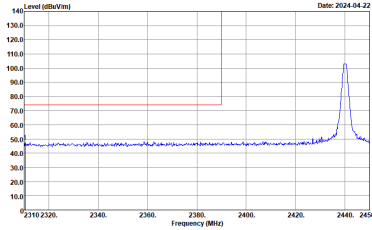
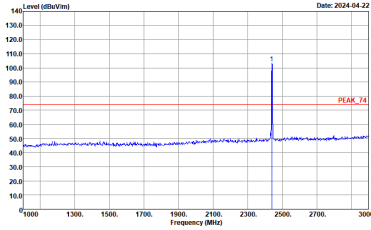
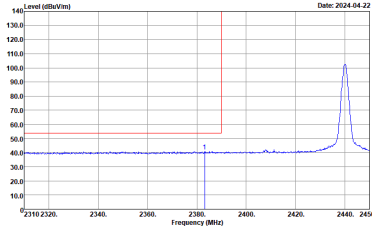
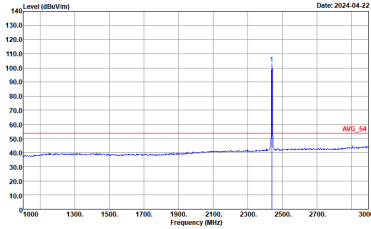

nRF	2.4GHz 2400~2483.5MHz Band Edge @ 3m	
nRF CH19 2440MHz - L		
Horizontal		Fundamental
Peak	 <p>Date: 2024-04-22</p> <p>Site : 03CH13-HY Condition : PEAK_BE_74 3m HORN_91200_1326 HORIZONTAL : RBW:1000.000KHz VBW:3000.000KHz SWT:Auto</p>	 <p>Date: 2024-04-22</p> <p>Site : 03CH13-HY Condition : PEAK_74 3m HORN_91200_1326 HORIZONTAL : RBW:1000.000KHz VBW:3000.000KHz SWT:Auto</p>
Avg.	 <p>Date: 2024-04-22</p> <p>Site : 03CH13-HY Condition : AVG_BE_54 3m HORN_91200_1326 HORIZONTAL : RBW:1000.000KHz VBW:10.000KHz SWT:Auto</p>	 <p>Date: 2024-04-22</p> <p>Site : 03CH13-HY Condition : AVG_54 3m HORN_91200_1326 HORIZONTAL : RBW:1000.000KHz VBW:10.000KHz SWT:Auto</p>

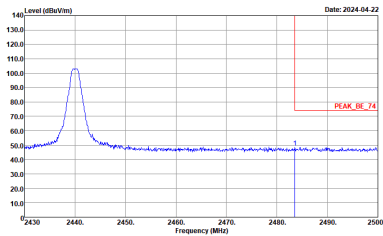
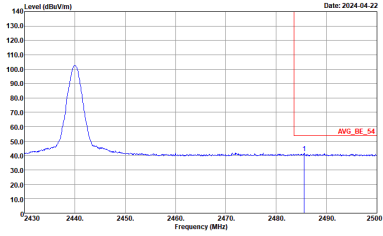

nRF	2.4GHz 2400~2483.5MHz Band Edge @ 3m	
	nRF CH19 2440MHz - R	
	Horizontal	Fundamental
<p>Peak</p>	 <p>Site : 03CH13-HY Condition : PEAK_BE_74 3m HORN_9120D_1326 HORIZONTAL : RBW:1000.000KHz VBW:3000.000KHz SWT:Auto</p>	<p>Left blank</p>
<p>Avg.</p>	 <p>Site : 03CH13-HY Condition : AVG_BE_54 3m HORN_9120D_1326 HORIZONTAL : RBW:1000.000KHz VBW:10.000KHz SWT:Auto</p>	<p>Left blank</p>

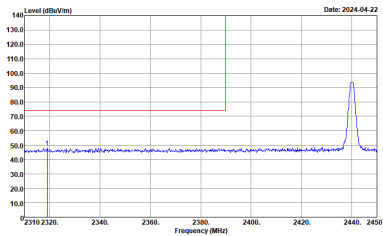
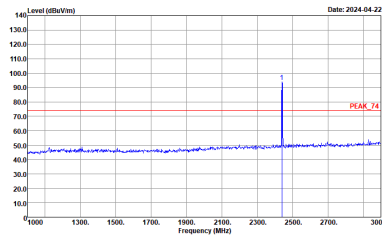
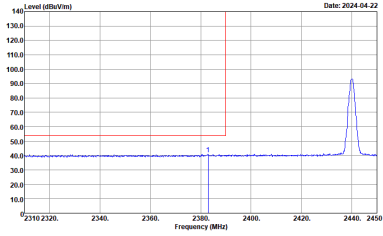
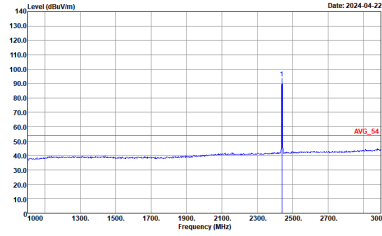

nRF	2.4GHz 2400~2483.5MHz Band Edge @ 3m	
nRF CH19 2440MHz - L		
Vertical		Fundamental
Peak	 <p>Site : 03CH13-HY Condition : PEAK_BE_74 3m HORN_91200_1326 VERTICAL : RBW:1000.000KHz VBW:3000.000KHz SWT:Auto</p>	 <p>Site : 03CH13-HY Condition : PEAK_74 3m HORN_91200_1326 VERTICAL : RBW:1000.000KHz VBW:3000.000KHz SWT:Auto</p>
Avg.	 <p>Site : 03CH13-HY Condition : AV6_BE_54 3m HORN_91200_1326 VERTICAL : RBW:1000.000KHz VBW:10.000KHz SWT:Auto</p>	 <p>Site : 03CH13-HY Condition : AV6_54 3m HORN_91200_1326 VERTICAL : RBW:1000.000KHz VBW:10.000KHz SWT:Auto</p>

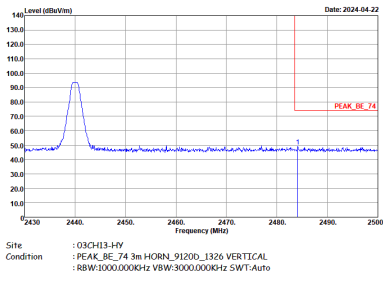
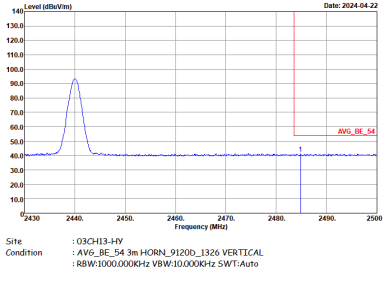

nRF	2.4GHz 2400~2483.5MHz Band Edge @ 3m	
	nRF CH19 2440MHz - R	
	Vertical	Fundamental
Peak	 <p>Site : 03CH13-HY Condition : PEAK_BE_74 3m HORN_9120D_1326 VERTICAL : RBW:1000.000kHz VBW:3000.000kHz SWT:Auto</p>	Left blank
Avg.	 <p>Site : 03CH13-HY Condition : AVG_BE_54 3m HORN_9120D_1326 VERTICAL : RBW:1000.000kHz VBW:10.000kHz SWT:Auto</p>	Left blank



nRF	2.4GHz 2400~2483.5MHz Band Edge @ 3m	
nRF CH38 2478MHz		
Horizontal		Fundamental
Peak	<p>Site : 03CH13-HY Condition : PEAK_BE_74 3m HORN_91200_1326 HORIZONTAL : RBW:1000.000KHz VBW:3000.000KHz SWT:Auto</p>	<p>Site : 03CH13-HY Condition : PEAK_74 3m HORN_91200_1326 HORIZONTAL : RBW:1000.000KHz VBW:3000.000KHz SWT:Auto</p>
Avg.	<p>Site : 03CH13-HY Condition : AV6_BE_54 3m HORN_91200_1326 HORIZONTAL : RBW:1000.000KHz VBW:10.000KHz SWT:Auto</p>	<p>Site : 03CH13-HY Condition : AV6_54 3m HORN_91200_1326 HORIZONTAL : RBW:1000.000KHz VBW:10.000KHz SWT:Auto</p>

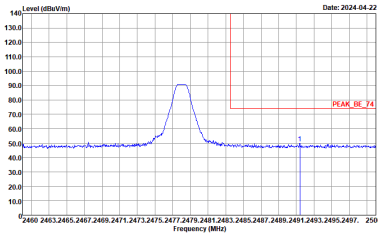
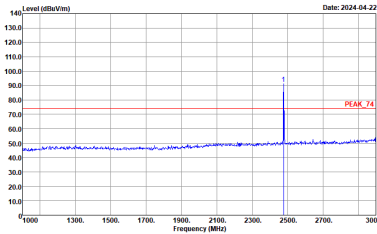
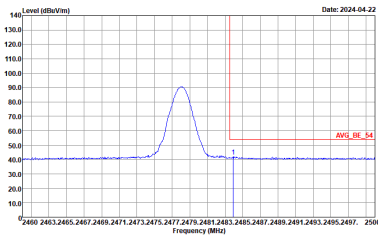
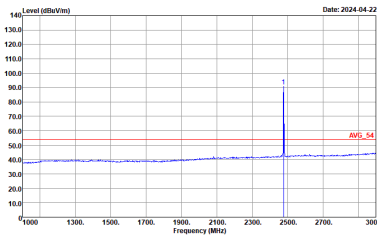

nRF	2.4GHz 2400~2483.5MHz Band Edge @ 3m	
nRF CH38 2478MHz		
Vertical		Fundamental
Peak	 <p>Level (dBm/100kHz) vs Frequency (MHz) plot showing a peak at 2478 MHz. The peak level is approximately 90 dBm/100kHz. The plot includes a red line indicating the peak level and a blue line for the spectrum. The x-axis ranges from 2460 to 2500 MHz, and the y-axis ranges from 10.0 to 140.0 dBm/100kHz.</p> <p>Site : 03CH13-HY Condition : PEAK_BE_74 3m HORN_91200_1326 VERTICAL : RBW:1000.000KHz VBW:3000.000KHz SWT:Auto</p>	 <p>Level (dBm/100kHz) vs Frequency (MHz) plot showing a sharp peak at 2478 MHz. The peak level is approximately 90 dBm/100kHz. The plot includes a red line indicating the peak level and a blue line for the spectrum. The x-axis ranges from 2460 to 3000 MHz, and the y-axis ranges from 10.0 to 140.0 dBm/100kHz.</p> <p>Site : 03CH13-HY Condition : PEAK_74 3m HORN_91200_1326 VERTICAL : RBW:1000.000KHz VBW:3000.000KHz SWT:Auto</p>
Avg.	 <p>Level (dBm/100kHz) vs Frequency (MHz) plot showing an average spectrum with a peak at 2478 MHz. The peak level is approximately 90 dBm/100kHz. The plot includes a red line indicating the average level and a blue line for the spectrum. The x-axis ranges from 2460 to 2500 MHz, and the y-axis ranges from 10.0 to 140.0 dBm/100kHz.</p> <p>Site : 03CH13-HY Condition : AV6_BE_54 3m HORN_91200_1326 VERTICAL : RBW:1000.000KHz VBW:10.000KHz SWT:Auto</p>	 <p>Level (dBm/100kHz) vs Frequency (MHz) plot showing an average spectrum with a sharp peak at 2478 MHz. The peak level is approximately 90 dBm/100kHz. The plot includes a red line indicating the average level and a blue line for the spectrum. The x-axis ranges from 2460 to 3000 MHz, and the y-axis ranges from 10.0 to 140.0 dBm/100kHz.</p> <p>Site : 03CH13-HY Condition : AV6_54 3m HORN_91200_1326 VERTICAL : RBW:1000.000KHz VBW:10.000KHz SWT:Auto</p>



2.4GHz 2400~2483.5MHz

nRF (Harmonic @ 3m)

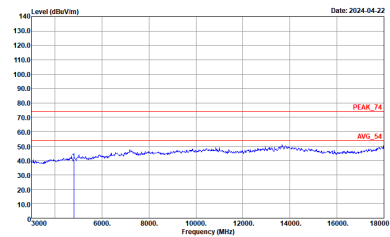
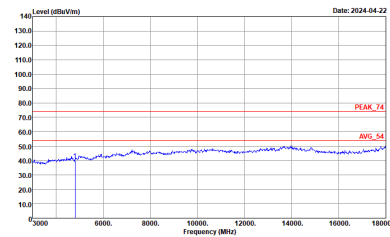
nRF	2.4GHz 2400~2483.5MHz Harmonic @ 3m	
	nRF CH00 2402MHz	
	Horizontal	Vertical
<p>Peak Avg.</p>	 <p>Site : 03CH13-HY Condition : PEAK_74 3m HORN_91200_1326 HORIZONTAL</p>	 <p>Site : 03CH13-HY Condition : PEAK_74 3m HORN_91200_1326 VERTICAL</p>

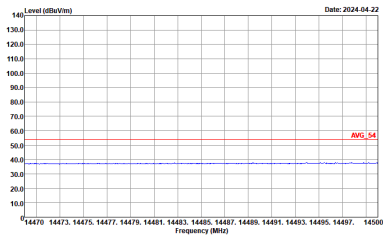
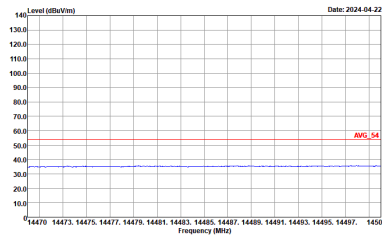
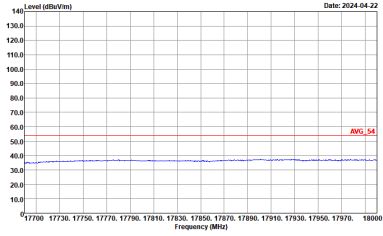
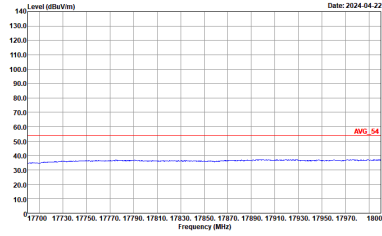

nRF	2.4GHz 2400~2483.5MHz Harmonic @ 3m	
	nRF CH00 2402MHz	
	Horizontal	Vertical
<p>14.47G ~14.5G Avg.</p>	 <p>Site : 03CH13-HY Condition : AV6_54 3m HORN_91200_1326 HORIZONTAL</p>	 <p>Site : 03CH13-HY Condition : AV6_54 3m HORN_91200_1326 VERTICAL</p>
<p>17.7G ~18G Avg.</p>	 <p>Site : 03CH13-HY Condition : AV6_54 3m HORN_91200_1326 HORIZONTAL</p>	 <p>Site : 03CH13-HY Condition : AV6_54 3m HORN_91200_1326 VERTICAL</p>

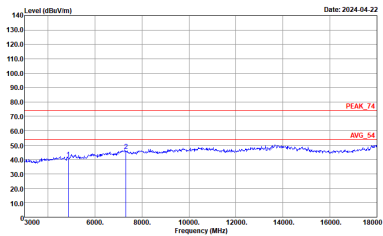
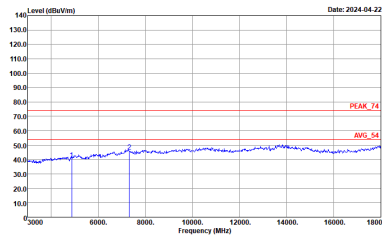

nRF	2.4GHz 2400~2483.5MHz Harmonic @ 3m	
	nRF CH19 2440MHz	
	Horizontal	Vertical
Peak Avg.	 <p>Site : 03CH13-HY Condition : PEAK_74 3m HORN_9120D_1326 HORIZONTAL</p>	 <p>Site : 03CH13-HY Condition : PEAK_74 3m HORN_9120D_1326 VERTICAL</p>

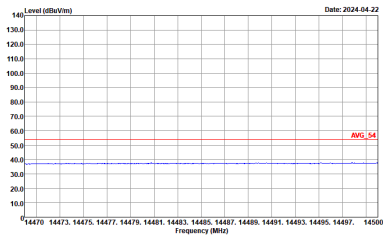
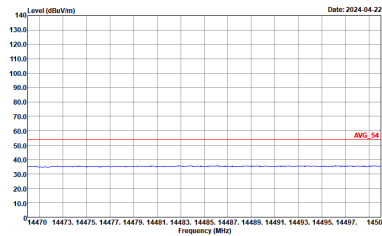
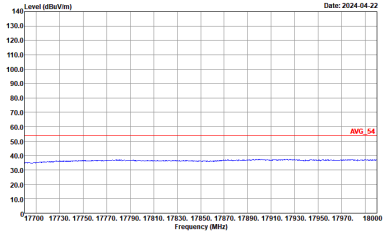
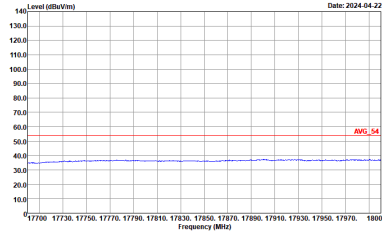

nRF	2.4GHz 2400~2483.5MHz Harmonic @ 3m	
nRF CH19 2440MHz		
Horizontal		Vertical
<p>14.47G ~14.5G Avg.</p>	 <p>Site : 03CH13-HY Condition : AV6_54 3m HORN_9120D_1326 HORIZONTAL</p>	 <p>Site : 03CH13-HY Condition : AV6_54 3m HORN_9120D_1326 VERTICAL</p>
<p>17.7G ~18G Avg.</p>	 <p>Site : 03CH13-HY Condition : AV6_54 3m HORN_9120D_1326 HORIZONTAL</p>	 <p>Site : 03CH13-HY Condition : AV6_54 3m HORN_9120D_1326 VERTICAL</p>

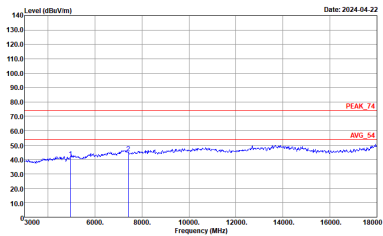
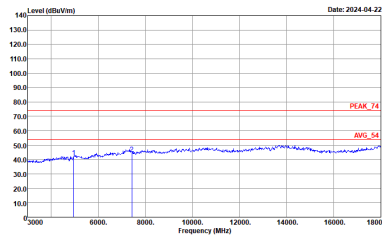

nRF	2.4GHz 2400~2483.5MHz Harmonic @ 3m	
	nRF CH38 2478MHz	
	Horizontal	Vertical
Peak	 <p>Site : 03CH13-HY Condition : PEAK_74 3m HORN_9120D_1326 HORIZONTAL</p>	 <p>Site : 03CH13-HY Condition : PEAK_74 3m HORN_9120D_1326 VERTICAL</p>

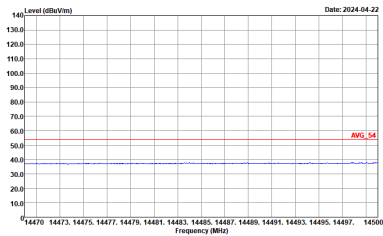
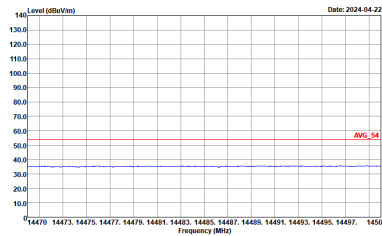
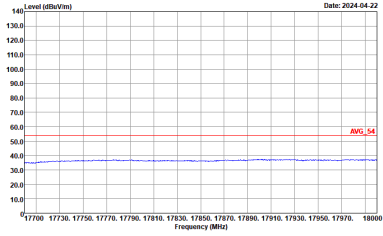
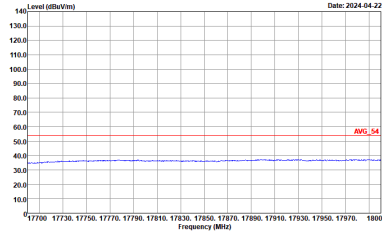

nRF	2.4GHz 2400~2483.5MHz Harmonic @ 3m	
nRF CH38 2478MHz		
Horizontal		Vertical
<p>14.47G ~14.5G Avg.</p>	 <p>Site : 03CH13-HY Condition : AV6_54 3m HORN_91200_1326 HORIZONTAL</p>	 <p>Site : 03CH13-HY Condition : AV6_54 3m HORN_91200_1326 VERTICAL</p>
<p>17.7G ~18G Avg.</p>	 <p>Site : 03CH13-HY Condition : AV6_54 3m HORN_91200_1326 HORIZONTAL</p>	 <p>Site : 03CH13-HY Condition : AV6_54 3m HORN_91200_1326 VERTICAL</p>



Emission above 18GHz

2.4GHz nRF (SHF @ 1m)

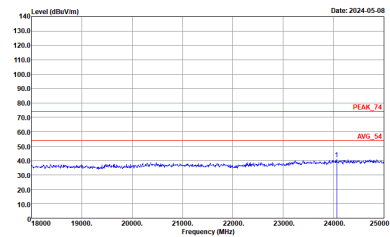
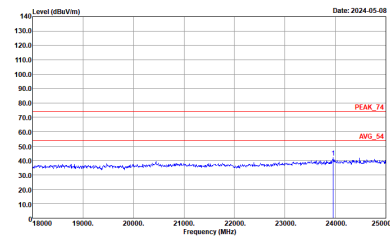
nRF	2.4GHz 2400~2483.5MHz	
	nRF SHF	
	Horizontal	Vertical
Peak Avg.	 <p>Site : 03CH13-HY Condition : PEAK_74 1m SHF_00993 HORIZONTAL</p>	 <p>Site : 03CH13-HY Condition : PEAK_74 1m SHF_00993 VERTICAL</p>



Emission below 1GHz

2.4GHz nRF (LF)

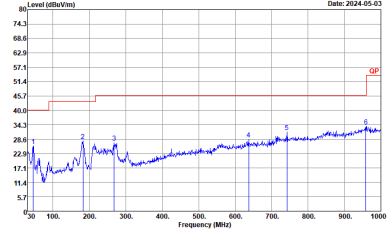
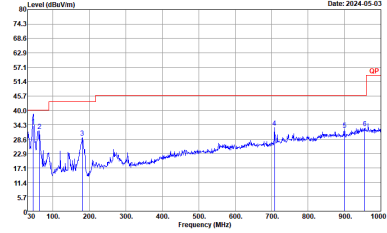
nRF	2.4GHz 2400~2483.5MHz	
	nRF LF	
	Horizontal	Vertical
QP / Peak	 <p>Site : 03CH13-HY Condition : QP 3m BIL06_40103 HORIZONTAL</p>	 <p>Site : 03CH13-HY Condition : QP 3m BIL06_40103 VERTICAL</p>



Appendix E. Duty Cycle Plots

Band	Duty Cycle(%)	T(us)	1/T(kHz)	VBW Setting
nRF	46.02	104	9.62	10kHz

