



FCC RADIO TEST REPORT

FCC ID : 2AGOZ-P4LK
Equipment : Media receiver
Brand Name : facebook
Model Name : WD50JM
Applicant : Facebook Technologies, LLC
1 Hacker Way, Menlo Park, CA 94025, USA
Standard : FCC Part 15 Subpart E §15.407

The product was received on May 24, 2019 and testing was started from Jun. 10, 2019 and completed on Jul. 09, 2019. We, SPORTON INTERNATIONAL INC., EMC & Wireless Communications Laboratory, would like to declare that the tested sample has been evaluated in accordance with the test procedures and has been in compliance with the applicable technical standards.

The report must not be used by the client to claim product certification, approval, or endorsement by TAF or any agency of government.

The test results in this report apply exclusively to the tested model / sample. Without written approval of SPORTON INTERNATIONAL INC. EMC & Wireless Communications Laboratory, the test report shall not be reproduced except in full.

Approved by: Jones Tsai

SPORTON INTERNATIONAL INC. EMC & Wireless Communications Laboratory
No. 52, Huaya 1st Rd., Guishan Dist., Taoyuan City, Taiwan (R.O.C.)



Table of Contents

History of this test report.....	3
Summary of Test Result.....	4
1 General Description	5
1.1 Product Feature of Equipment Under Test.....	5
1.2 Modification of EUT	5
1.3 Testing Location	5
1.4 Applicable Standards.....	6
2 Test Configuration of Equipment Under Test	7
2.1 Carrier Frequency and Channel	7
2.2 Test Mode.....	8
2.3 Connection Diagram of Test System.....	10
2.4 Support Unit used in test configuration and system	11
2.5 EUT Operation Test Setup	11
2.6 Measurement Results Explanation Example.....	11
3 Test Result	12
3.1 26dB & 99% Occupied Bandwidth Measurement	12
3.2 Maximum Conducted Output Power Measurement	14
3.3 Power Spectral Density Measurement	16
3.4 Unwanted Emissions Measurement.....	19
3.5 AC Conducted Emission Measurement.....	24
3.6 Automatically Discontinue Transmission	26
3.7 Antenna Requirements.....	28
4 List of Measuring Equipment.....	29
5 Uncertainty of Evaluation	31
Appendix A. Conducted Test Results	
Appendix B. AC Conducted Emission Test Result	
Appendix C. Radiated Spurious Emission	
Appendix D. Radiated Spurious Emission Plots	
Appendix E. Duty Cycle Plots	
Appendix F. Setup Photographs	



History of this test report

Report No.	Version	Description	Issued Date
FR952409D	01	Initial issue of report	Jul. 12, 2019
FR952409D	02	Revise the connection diagram of test system in section 2.3	Jul. 29, 2019



Summary of Test Result

Report Clause	Ref Std. Clause	Test Items	Result (PASS/FAIL)	Remark
3.1	15.403(i)	26dB Bandwidth	Pass	-
3.1	2.1049	99% Occupied Bandwidth	Reporting only	-
3.2	15.407(a)	Maximum Conducted Output Power	Pass	-
3.3	15.407(a)	Power Spectral Density	Pass	-
3.4	15.407(b)	Unwanted Emissions	Pass	Under limit 1.98 dB at 5457.520 MHz
3.5	15.207	AC Conducted Emission	Pass	Under limit 13.20 dB at 0.161 MHz
3.6	15.407(c)	Automatically Discontinue Transmission	Pass	-
3.7	15.203 15.407(a)	Antenna Requirement	Pass	-

Declaration of Conformity:

The test results with all measurement uncertainty excluded are presented in accordance with the regulation limits or requirements declared by manufacturers.

Comments and Explanations:

The declared of product specification for EUT presented in the report are provided by the manufacturer, and the manufacturer takes all the responsibilities for the accuracy of product specification.

Reviewed by: Wii Chang**Report Producer: Elise Chang**



1 General Description

1.1 Product Feature of Equipment Under Test

Bluetooth, Wi-Fi 2.4GHz 802.11b/g/n/ac, and Wi-Fi 5GHz 802.11a/n/ac

Product Specification subjective to this standard	
Antenna Type	WLAN <Ant. 1>: FPC Antenna <Ant. 2>: FPC Antenna Bluetooth: FPC Antenna

1.2 Modification of EUT

No modifications are made to the EUT during all test items.

1.3 Testing Location

Test Site	SPORTON INTERNATIONAL INC. EMC & Wireless Communications Laboratory		
Test Site Location	No.52, Huaya 1st Rd., Guishan Dist., Taoyuan City, Taiwan (R.O.C.) TEL: +886-3-327-3456 FAX: +886-3-328-4978		
Test Site No.	Sporton Site No.		
	TH05-HY	CO05-HY	DFS02-HY

Note: The test site complies with ANSI C63.4 2014 requirement.

Test Site	SPORTON INTERNATIONAL INC. EMC & Wireless Communications Laboratory		
Test Site Location	No.58, Aly. 75, Ln. 564, Wenhua 3rd, Rd., Guishan Dist., Taoyuan City, Taiwan (R.O.C.) TEL: +886-3-327-0868 FAX: +886-3-327-0855		
Test Site No.	Sporton Site No.		
	03CH12-HY		

Note: The test site complies with ANSI C63.4 2014 requirement.

FCC designation No.: TW1190 and TW0007



1.4 Applicable Standards

According to the specifications of the manufacturer, the EUT must comply with the requirements of the following standards:

- ♦ FCC Part 15 Subpart E
- ♦ FCC KDB 789033 D02 General UNII Test Procedures New Rules v02r01.
- ♦ FCC KDB 414788 D01 Radiated Test Site v01r01.
- ♦ FCC KDB 662911 D01 Multiple Transmitter Output v02r01.
- ♦ ANSI C63.10-2013

Remark:

1. All test items were verified and recorded according to the standards and without any deviation during the test.
2. This EUT has also been tested and complied with the requirements of FCC Part 15, Subpart B, recorded in a separate test report.



2 Test Configuration of Equipment Under Test

- a. The EUT has been associated with peripherals and configuration operated in a manner tended to maximize its emission characteristics in a typical application. Frequency range investigated: conduction emission (150 kHz to 30 MHz), radiation emission (9 kHz to the 10th harmonic of the highest fundamental frequency or to 40 GHz, whichever is lower). For radiated measurement, pre-scanned in three orthogonal panels, X, Y, Z. The worst cases (Y plane) were recorded in this report.
- b. AC power line Conducted Emission was tested under maximum output power.

2.1 Carrier Frequency and Channel

Frequency Band	Channel	Freq. (MHz)	Channel	Freq. (MHz)
5150-5250 MHz Band 1 (U-NII-1)	36	5180	44	5220
	38*	5190	46*	5230
	40	5200	48	5240
	42 [#]	5210		

Frequency Band	Channel	Freq. (MHz)	Channel	Freq. (MHz)
5250-5350 MHz Band 2 (U-NII-2A)	52	5260	60	5300
	54*	5270	62*	5310
	56	5280	64	5320
	58 [#]	5290		

Frequency Band	Channel	Freq. (MHz)	Channel	Freq. (MHz)
5470-5725 MHz Band 3 (U-NII-2C)	100	5500	112	5560
	102*	5510	116	5580
	104	5520	132	5660
	106 [#]	5530	134*	5670
	108	5540	136	5680
	110*	5550	140	5700

Frequency Band	Channel	Freq. (MHz)	Channel	Freq. (MHz)
TDWR Channel	118*	5590	124	5620
	120	5600	126*	5630
	122 [#]	5610	128	5640



Frequency Band	Channel	Freq. (MHz)	Channel	Freq. (MHz)
Straddle Channel	138 [#]	5690	144	5720
	142 [*]	5710		

Note:

1. The above Frequency and Channel in "*" were 802.11n HT40 and 802.11ac VHT40.
2. The above Frequency and Channel in "#" were 802.11ac VHT80.

2.2 Test Mode

Final test modes are considering the modulation and worse data rates as below table.

MIMO Mode

Modulation	Data Rate
802.11a	6 Mbps
802.11n HT20 (Covered by VHT20)	MCS0
802.11n HT40 (Covered by VHT40)	MCS0
802.11ac VHT20	MCS0
802.11ac VHT40	MCS0
802.11ac VHT80	MCS0

Test Cases	
AC Conducted Emission	Mode 1 : WLAN (5GHz) Link + Bluetooth Link + Thermal Test + USB Type C Cable to RJ45 Cable (Load) + AC Adapter



Ch. #		Band I : 5150-5250 MHz	Band II : 5250-5350 MHz	Band III : 5470-5725MHz
		802.11a	802.11a	802.11a
L	Low	36	52	100
M	Middle	44	60	116
H	High	48	64	140
Straddle		-	-	144

Ch. #		Band I : 5150-5250 MHz	Band II : 5250-5350 MHz	Band III : 5470-5725MHz
		802.11ac VHT20	802.11ac VHT20	802.11ac VHT20
L	Low	36	52	100
M	Middle	44	60	116
H	High	48	64	140
Straddle		-	-	144

Ch. #		Band I : 5150-5250 MHz	Band II : 5250-5350 MHz	Band III : 5470-5725MHz
		802.11ac VHT40	802.11ac VHT40	802.11ac VHT40
L	Low	38	54	102
M	Middle	-	-	110
H	High	46	62	134
Straddle		-	-	142

Ch. #		Band I : 5150-5250 MHz	Band II : 5250-5350 MHz	Band III : 5470-5725MHz
		802.11ac VHT80	802.11ac VHT80	802.11ac VHT80
L	Low	-	-	106
M	Middle	42	58	-
H	High	-	-	122
Straddle		-	-	138

2.3 Connection Diagram of Test System

<WLAN Tx Mode>

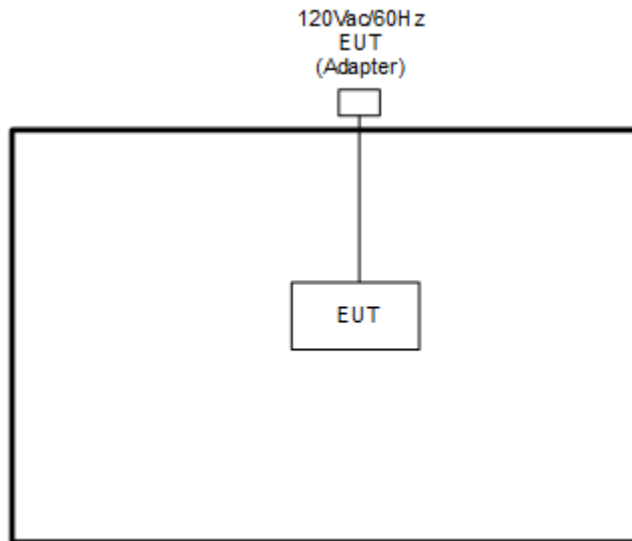

<AC Conducted Emission Mode>

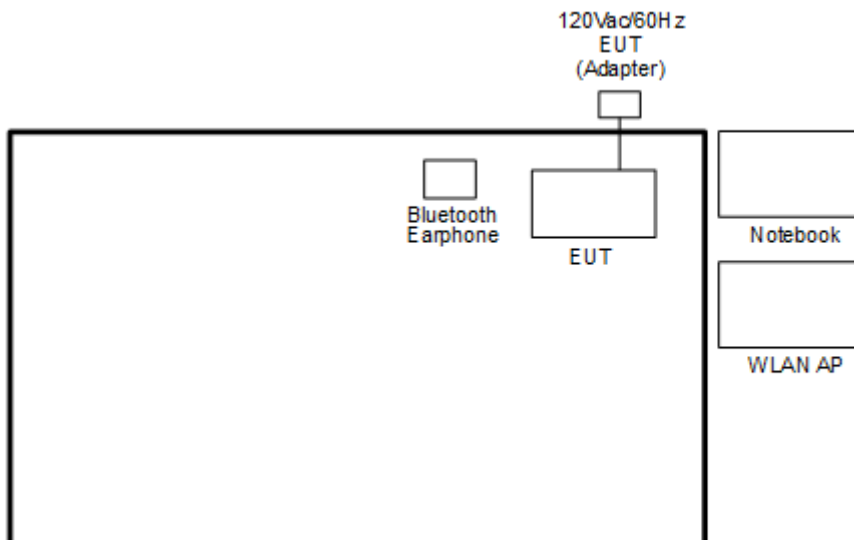



2.4 Support Unit used in test configuration and system

Item	Equipment	Trade Name	Model Name	FCC ID	Data Cable	Power Cord
1.	Bluetooth Earphone	Sony Ericsson	MW600	PY7DDA-2029	N/A	N/A
2.	WLAN AP	ASUS	RT-AC66U	MSQ-RTAC66U	N/A	Unshielded, 1.8 m
3.	Notebook	DELL	Latitude E6320	FCC DoC	N/A	AC I/P: Unshielded, 1.2 m DC O/P: Shielded, 1.8 m

2.5 EUT Operation Test Setup

The RF test items, utility “QRCT” was installed in Notebook which was programmed in order to make the EUT get into the engineering modes to provide channel selection, power level, data rate and the application type and for continuous transmitting signals.

Remark:

QRCT Version 4.0.00067 for Radiated Spurious Emission

QRCT Version 4.0.00108 for Conducted

2.6 Measurement Results Explanation Example

For all conducted test items:

The offset level is set in the spectrum analyzer to compensate the RF cable loss and attenuator factor between EUT conducted output port and spectrum analyzer. With the offset compensation, the spectrum analyzer reading level is exactly the EUT RF output level.

Example :

The spectrum analyzer offset is derived from RF cable loss and attenuator factor.

Offset = RF cable loss + attenuator factor.

Following shows an offset computation example with cable loss 4.2 dB and 10dB attenuator.

$$\begin{aligned} \text{Offset(dB)} &= \text{RF cable loss(dB)} + \text{attenuator factor(dB)}. \\ &= 4.2 + 10 = 14.2 \text{ (dB)} \end{aligned}$$

3 Test Result

3.1 26dB & 99% Occupied Bandwidth Measurement

3.1.1 Description of 26dB & 99% Occupied Bandwidth

This section is for reporting purpose only.

There is no restriction limits for bandwidth.

For Straddle Channel, according to KDB 789033 D02 General UNII Test Procedures New Rules v02r01, if the power and PSD of the devices are uniform and comply with the lower limits specified for the U-NII-2 bands, a single measurement over the entire emission bandwidth can be performed to show compliance.

3.1.2 Measuring Instruments

See list of measuring equipment of this test report.

3.1.3 Test Procedures

1. The testing follows FCC KDB 789033 D02 General UNII Test Procedures New Rules v02r01. Section C) Emission bandwidth
2. Set RBW = approximately 1% of the emission bandwidth.
3. Set the VBW > RBW.
4. Detector = Peak.
5. Trace mode = max hold
6. Measure the maximum width of the emission that is 26 dB down from the peak of the emission. Compare this with the RBW setting of the analyzer. Readjust RBW and repeat measurement as needed until the RBW/EBW ratio is approximately 1%.
7. For 99% Bandwidth Measurement, the spectrum analyzer's resolution bandwidth (RBW) is set 1-5% of the emission bandwidth and set the Video bandwidth (VBW) $\geq 3 * RBW$.
8. Measure and record the results in the test report.

3.1.4 Test Setup

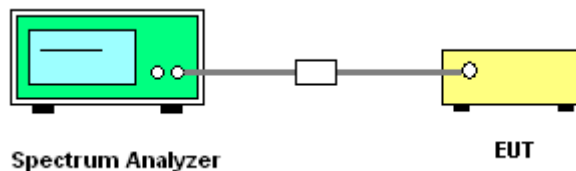

3.1.5 Test Result of 26dB & 99% Occupied Bandwidth

Please refer to Appendix A.

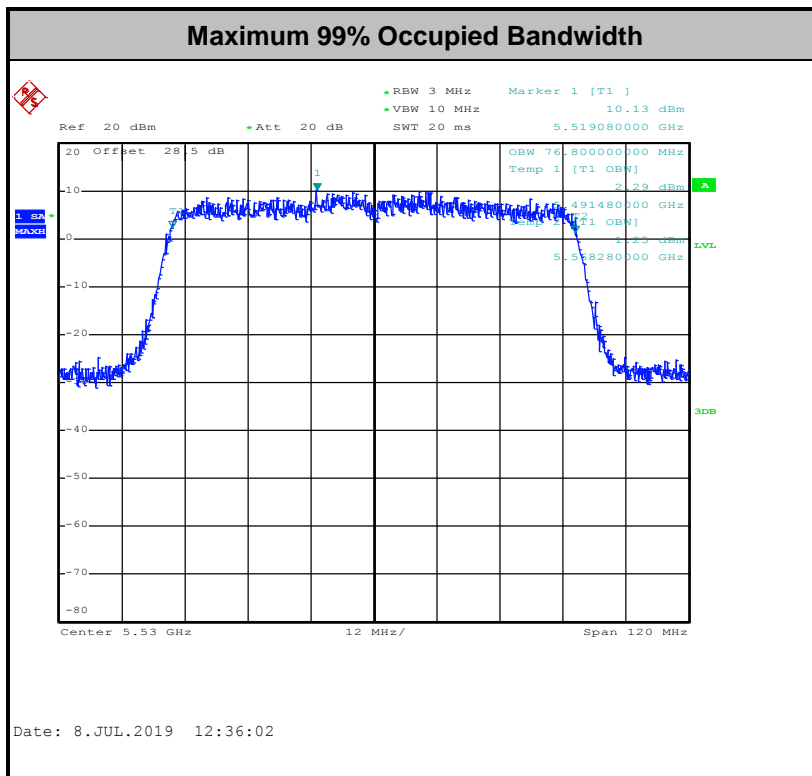
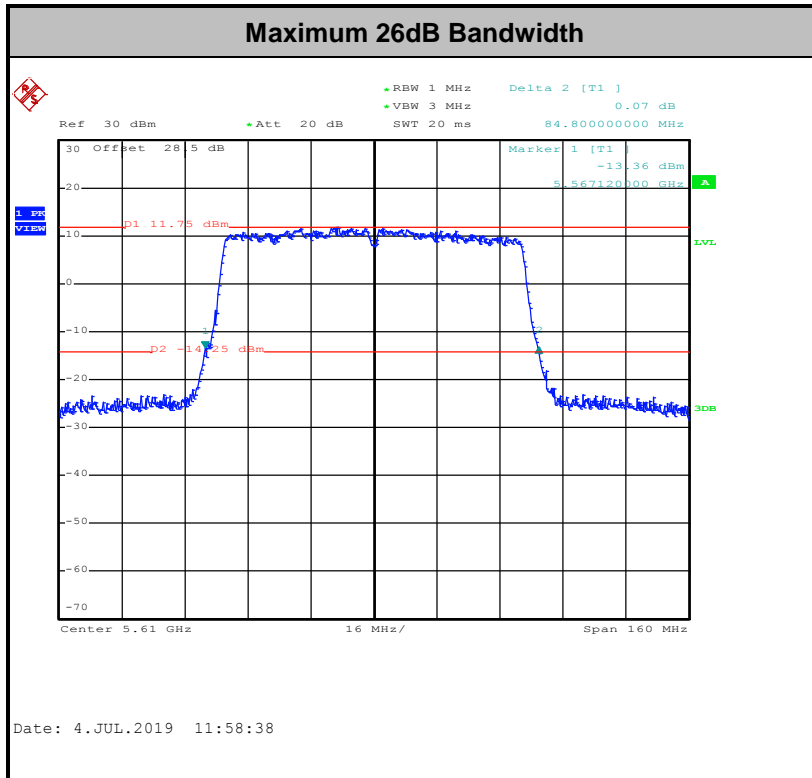

Note: The occupied channel bandwidth is maintained within the band of operation for all of the modulations.



3.2 Maximum Conducted Output Power Measurement

3.2.1 Limit of Maximum Conducted Output Power

<FCC 14-30 CFR 15.407>

For the 5.15–5.25 GHz bands:

- For mobile and portable client devices in the 5.15–5.25 GHz band, the maximum conducted output power over the frequency band of operation shall not exceed 250 mW. For an indoor access point operating in the band 5.15-5.25 GHz, the maximum conducted output power over the frequency band of operation shall not exceed 1 W.

For the 5.25–5.725 GHz bands:

- The maximum conducted output power over the frequency bands of operation shall not exceed the lesser of 250 mW or $11 \text{ dBm} + 10 \log B$, where B is the 26 dB emission bandwidth in megahertz.

For Straddle Channel, according to KDB 789033 D02 General UNII Test Procedures New Rules v02r01, if the power and PSD of the devices are uniform and comply with the lower limits specified for the U-NII-2 bands, a single measurement over the entire emission bandwidth can be performed to show compliance.

If transmitting antennas of directional gain greater than 6 dBi are used, the peak output power shall be reduced by the amount in dB that the directional gain of the antenna exceeds 6 dBi.

Note that U-NII-2 band, devices with a maximum e.i.r.p. greater than 500 mW shall implement TPC in order to have the capability to operate at least 6 dB below the maximum permitted e.i.r.p. of 1 W.

3.2.2 Measuring Instruments

See list of measuring equipment of this test report.

3.2.3 Test Procedures

The testing follows Method PM-G of FCC KDB 789033 D02 General UNII Test Procedures New Rules v02r01.

Method PM-G (Measurement using an RF average power meter):

1. Measurement is performed using a wideband RF power meter.
2. The EUT is configured to transmit at its maximum power control level.
3. Measure the average power of the transmitter
4. Since the measurement is made only during the ON time of the transmitter, no duty cycle correction factor is required.

For Straddle Channel, according to KDB 789033 D02 General UNII Test Procedures New Rules v02r01, if the power and PSD of the devices are uniform and comply with the lower limits specified for the U-NII-2 bands, a single measurement over the entire emission bandwidth can be performed to show compliance.

3.2.4 Test Setup

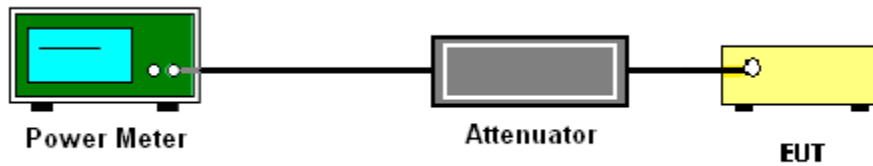

3.2.5 Test Result of Maximum Conducted Output Power

Please refer to Appendix A.



3.3 Power Spectral Density Measurement

3.3.1 Limit of Power Spectral Density

<FCC 14-30 CFR 15.407>

For the 5.15–5.25 GHz bands:

For mobile and portable client devices in the 5.15–5.25 GHz band, the maximum power spectral density shall not exceed 11 dBm in any 1.0 MHz band. For an indoor access point operating in the band 5.15-5.25 GHz, the maximum power spectral density shall not exceed 17 dBm in any 1.0 MHz band.

For the 5.25–5.725 GHz bands:

The maximum power spectral density shall not exceed 11 dBm in any 1.0 MHz band.

For Straddle Channel, according to KDB 789033 D02 General UNII Test Procedures New Rules v02r01, if the power and PSD of the devices are uniform and comply with the lower limits specified for the U-NII-2 bands, a single measurement over the entire emission bandwidth can be performed to show compliance.

If transmitting antennas of directional gain greater than 6 dBi are used, the peak output power shall be reduced by the amount in dB that the directional gain of the antenna exceeds 6 dBi.

3.3.2 Measuring Instruments

See list of measuring equipment of this test report.

3.3.3 Test Procedures

The testing follows FCC KDB 789033 D02 General UNII Test Procedures New Rules v02r01.
Section F) Maximum power spectral density.

Method SA-2

(trace averaging across on and off times of the EUT transmissions, followed by duty cycle correction).

- Measure the duty cycle.
 - Set span to encompass the entire emission bandwidth (EBW) of the signal.
 - Set RBW = 1 MHz.
 - Set VBW \geq 3 MHz.
 - Number of points in sweep \geq 2 Span / RBW.
 - Sweep time = auto.
 - Detector = RMS
 - Trace average at least 100 traces in power averaging mode.
 - Add $10 \log(1/x)$, where x is the duty cycle, to the measured power in order to compute the average power during the actual transmission times. For example, add $10 \log(1/0.25) = 6$ dB if the duty cycle is 25 percent.
1. The RF output of EUT was connected to the spectrum analyzer by a low loss cable.
 2. Each plot has already offset with cable loss, and attenuator loss. Measure the PPSD and record it.
 3. For MIMO mode, calculation method follows FCC KDB 662911 D01 Multiple Transmitter Output v02r01.

Method (a): Measure and sum the spectra across the outputs.

The total final Power Spectral Density is from a device with 2 transmitter outputs. The spectrum measurements of the individual outputs are all performed with the same span and number of points; the spectrum value in the first spectral bin of output 1 is summed with that in the first spectral bin of output 2 to obtain the value for the first frequency bin of the summed spectrum.

3.3.4 Test Setup

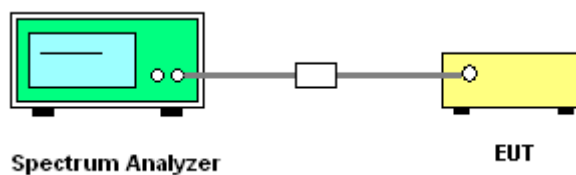



3.3.5 Test Result of Power Spectral Density

Please refer to Appendix A.

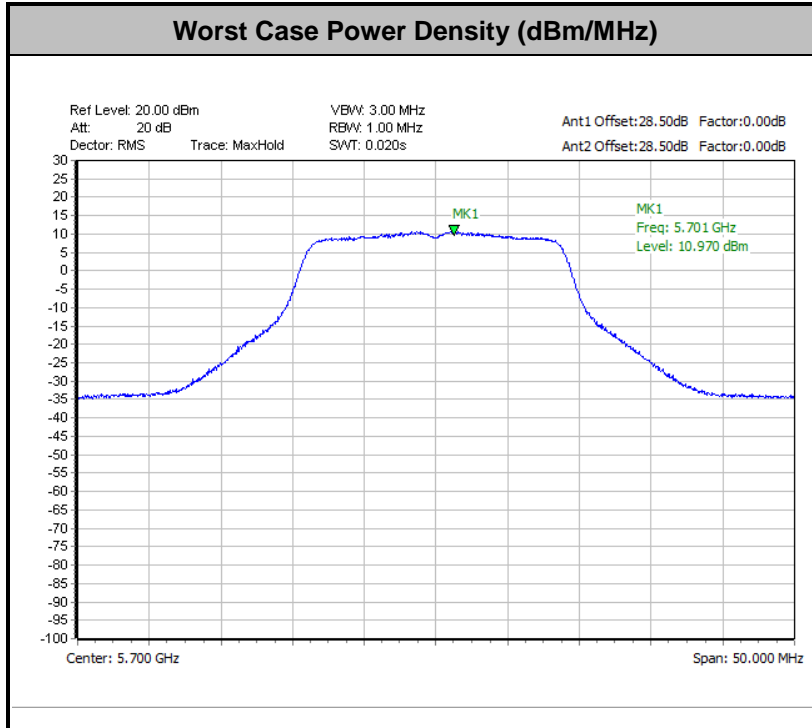

Note: Average Power Density (dB) = Measured value+ Duty Factor



3.4 Unwanted Emissions Measurement

This section is to measure unwanted emissions through radiated measurement for band edge spurious emissions and out of band emissions measurement.

3.4.1 Limit of Unwanted Emissions

- (1) For transmitters operating in the 5150-5250 MHz band: all emissions outside of the 5150-5350 MHz band shall not exceed an EIRP of -27dBm/MHz.

For transmitters operating in the 5250-5350 MHz band: all emissions outside of the 5150-5350 MHz band shall not exceed an EIRP of -27 dBm/MHz. Devices operating in the 5250-5350 MHz band that generate emissions in the 5150-5250 MHz band must meet all applicable technical requirements for operation in the 5150-5250 MHz band (including indoor use) or alternatively meet an out-of-band emission EIRP limit of -27 dBm/MHz in the 5150-5250 MHz band.

For transmitters operating in the 5470-5600 MHz and 5650-5725MHz band: all emissions outside of the 5470-5600 MHz and 5650-5725MHz band shall not exceed an EIRP of -27 dBm/MHz.

- (2) Unwanted spurious emissions fallen in restricted bands shall comply with the general field strength limits as below table:

Frequency (MHz)	Field Strength (microvolts/meter)	Measurement Distance (meters)
0.009 – 0.490	2400/F(kHz)	300
0.490 – 1.705	24000/F(kHz)	30
1.705 – 30.0	30	30
30 – 88	100	3
88 – 216	150	3
216 - 960	200	3
Above 960	500	3

Note: The following formula is used to convert the EIRP to field strength.

$$E = \frac{1000000\sqrt{30P}}{3} \text{ } \mu\text{V/m, where P is the eirp (Watts)}$$

EIRP (dBm)	Field Strength at 3m (dBμV/m)
- 27	68.3



- (3) KDB789033 D02 v02r01 G)2)c)
 - (i) Section 15.407(b)(1) to (b)(3) specify the unwanted emission limits for the U-NII-1 and U-NII-2 bands. As specified, emissions above 1000 MHz that are outside of the restricted bands are subject to a peak emission limit of -27 dBm/MHz.³
 - (ii) Section 15.407(b)(4) specifies the unwanted emission limit for the U-NII-3 band. A band emissions mask is specified in Section 15.407(b)(4)(i). The emission limits are in terms of a Peak detector. An alternative to the band emissions mask is specified in Section 15.407(b)(4)(ii). The alternative limits are based on the highest antenna gain specified in the filing. There are also marketing and importation restrictions for the devices using the alternative limit.⁴

Note 3: An out-of-band emission that complies with both the average and peak limits of Section 15.209 is not required to satisfy the -27 dBm/MHz peak emission limit.

Note 4: Only devices with antenna gains of 10 dBi or less may be approved using the emission limits specified in Section 15.247(d) till March 2, 2018; all other devices operating in this band must use the mask specified in Section 15.407(b)(4)(i).

3.4.2 Measuring Instruments

See list of measuring equipment of this test report.

3.4.3 Test Procedures

1. The testing follows FCC KDB 789033 D02 General UNII Test Procedures New Rules v02r01. Section G) Unwanted emissions measurement.
 - (1) Procedure for Unwanted Emissions Measurements Below 1000MHz
 - RBW = 120 kHz
 - VBW = 300 kHz
 - Detector = Peak
 - Trace mode = max hold
 - (2) Procedure for Peak Unwanted Emissions Measurements Above 1000 MHz
 - RBW = 1 MHz
 - VBW ≥ 3 MHz
 - Detector = Peak
 - Sweep time = auto
 - Trace mode = max hold
 - (3) Procedures for Average Unwanted Emissions Measurements Above 1000MHz
 - RBW = 1 MHz
 - VBW = 10 Hz, when duty cycle is no less than 98 percent.
 - VBW ≥ 1/T, when duty cycle is less than 98 percent where T is the minimum transmission duration over which the transmitter is on and is transmitting at its maximum power control level for the tested mode of operation.



2. The EUT was placed on a turntable with 0.8 meter for frequency below 1GHz and 1.5 meter for frequency above 1GHz respectively above ground.
3. The EUT was set 3 meters from the interference receiving antenna which was mounted on the top of a variable height antenna tower.
4. The antenna is a broadband antenna and its height is adjusted between one meter and four meters above ground to find the maximum value of the field strength for both horizontal polarization and vertical polarization of the antenna.
5. For each suspected emission, the EUT was arranged to its worst case and then adjust the antenna tower (from 1 m to 4 m) and turntable (from 0 degree to 360 degrees) to find the maximum reading.
6. For testing below 1GHz, if the emission level of the EUT in peak mode was 3 dB lower than the limit specified, then peak values of EUT will be reported, otherwise, the emissions will be repeated one by one using the CISPR quasi-peak method and reported.
7. For testing above 1GHz, the emission level of the EUT in peak mode was 20dB lower than average limit (that means the emission level in average mode also complies with the limit in average mode), then peak values of EUT will be reported, otherwise, the emissions will be measured in average mode again and reported.

3.4.4 Test Setup

For radiated emissions below 30MHz

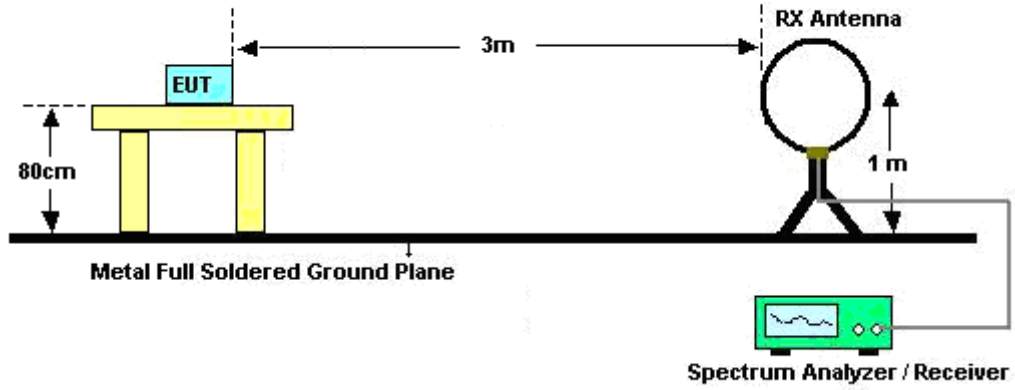

For radiated emissions from 30MHz to 1GHz

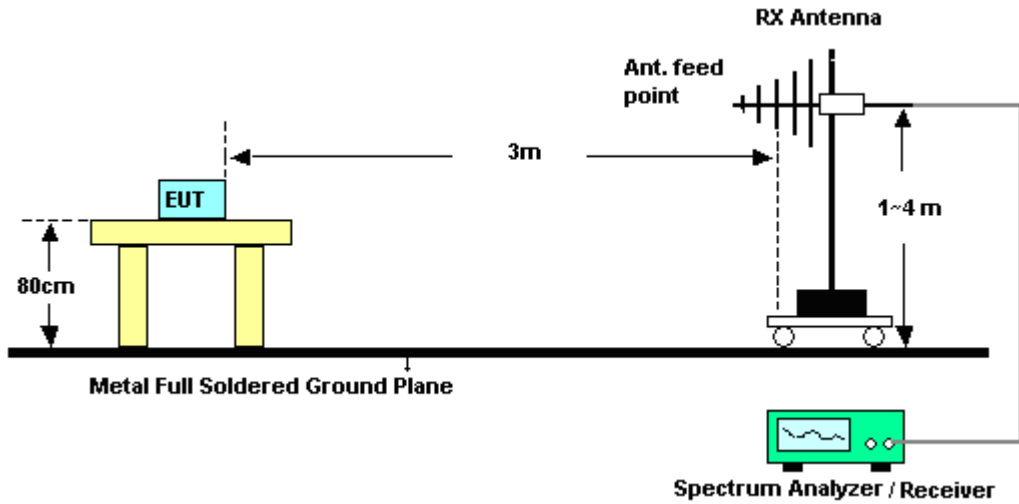

For radiated emissions above 1GHz

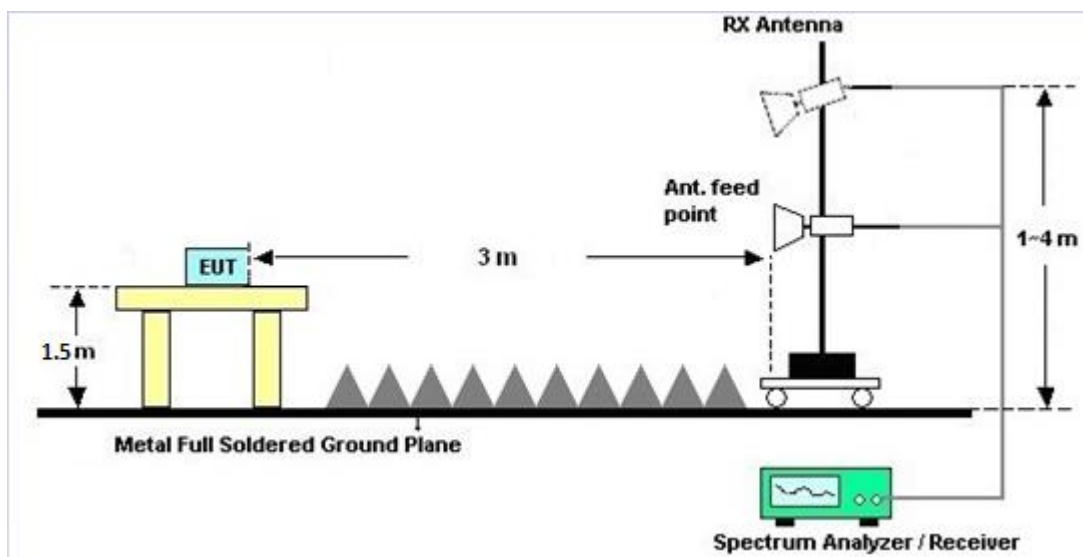



3.4.5 Test Results of Radiated Spurious Emissions (9 kHz ~ 30 MHz)

The low frequency, which started from 9 kHz to 30MHz, was pre-scanned and the result which was 20dB lower than the limit line was not reported.

There is a comparison data of both open-field test site and alternative test site - semi-Anechoic chamber according to 414788 D01 Radiated Test Site v01r01, and the result came out very similar.

3.4.6 Test Result of Radiated Spurious at Band Edges

Please refer to Appendix C and D.

3.4.7 Duty Cycle

Please refer to Appendix E.

3.4.8 Test Result of Radiated Spurious Emissions (30MHz ~ 10th Harmonic)

Please refer to Appendix C and D.



3.5 AC Conducted Emission Measurement

3.5.1 Limit of AC Conducted Emission

For equipment that is designed to be connected to the public utility (AC) power line, the radio frequency voltage that is conducted back onto the AC power line on any frequency or frequencies within the band 150 kHz to 30 MHz shall not exceed the limits in the following table.

Frequency of emission (MHz)	Conducted limit (dB μ V)	
	Quasi-peak	Average
0.15-0.5	66 to 56*	56 to 46*
0.5-5	56	46
5-30	60	50

*Decreases with the logarithm of the frequency.

3.5.2 Measuring Instruments

See list of measuring equipment of this test report.

3.5.3 Test Procedures

1. The EUT was placed 0.4 meter from the conducting wall of the shielding room was kept at least 80 centimeters from any other grounded conducting surface.
2. Connect EUT to the power mains through a line impedance stabilization network (LISN).
3. All the support units are connecting to the other LISN.
4. The LISN provides 50 ohm coupling impedance for the measuring instrument.
5. The FCC states that a 50 ohm, 50 microhenry LISN should be used.
6. Both sides of AC line were checked for maximum conducted interference.
7. The frequency range from 150 kHz to 30 MHz was searched.
8. Set the test-receiver system to Peak Detect Function and specified bandwidth with Maximum Hold Mode.

3.5.4 Test Setup

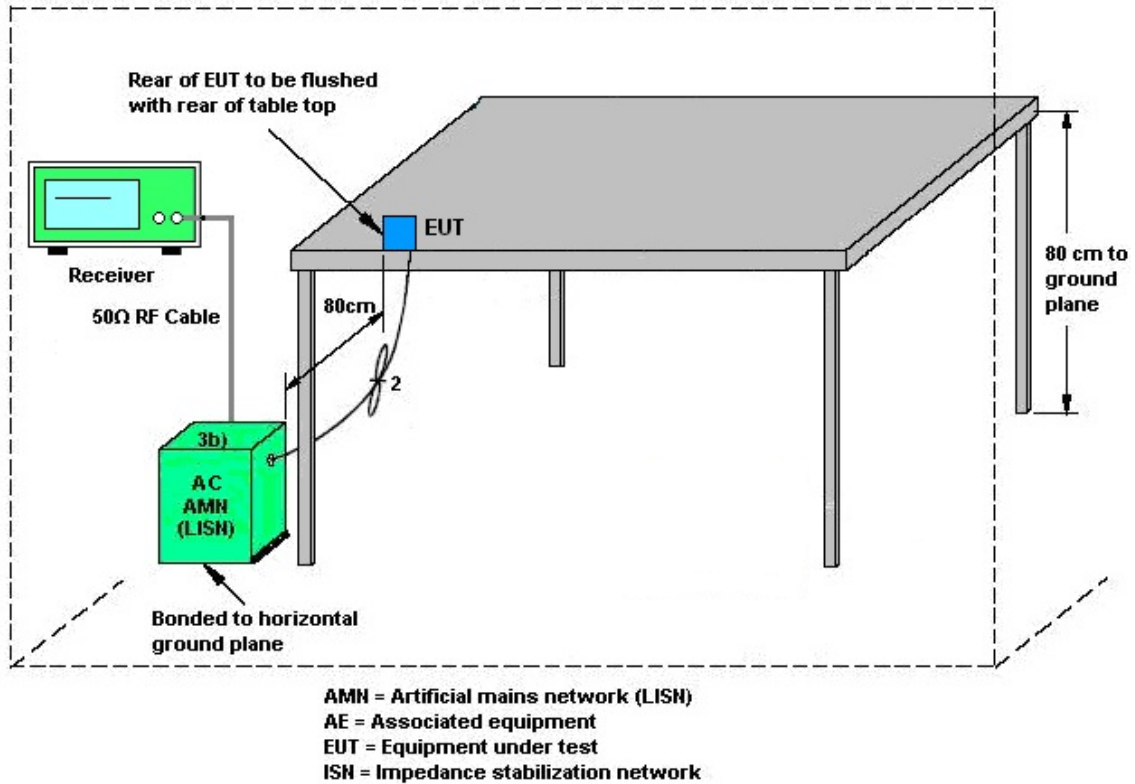

3.5.5 Test Result of AC Conducted Emission

Please refer to Appendix B.



3.6 Automatically Discontinue Transmission

3.6.1 Limit of Automatically Discontinue Transmission

The device shall automatically discontinue transmission in case of either absence of information to transmit or operational failure. These provisions are not intended to preclude the transmission of control or signaling information or the use of repetitive codes used by certain digital technologies to complete frame or burst intervals. Applicants shall include in their application for equipment authorization to describe how this requirement is met.

3.6.2 Measuring Instruments

See list of measuring equipment of this test report.

3.6.3 Test Result of Automatically Discontinue Transmission

EUT is verified this characteristic during the function check of normal sample associated with an access point:

- A. Information start: make EUT supply information to the access point.
- B. Information stop: stop supplying information to the access point.

While the EUT is not transmitting any information, the EUT can automatically discontinue transmission and become standby mode for power saving.

- C. Information start: make EUT supply information to the access point again.

The EUT can detect the controlling signal of ACK message transmitting from remote device and verify whether it shall resend or discontinue transmission.

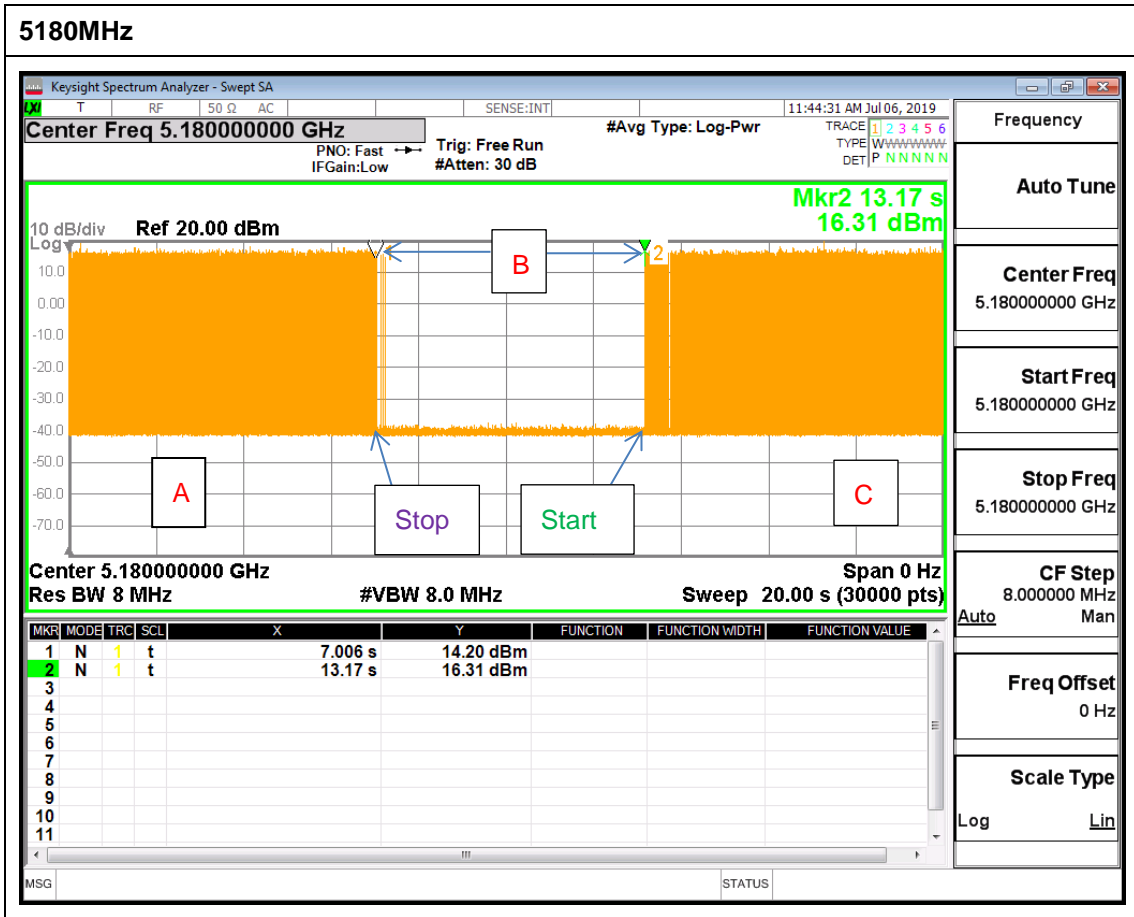

Note: The control / signaling information during the period B is precluded.



3.7 Antenna Requirements

3.7.1 Standard Applicable

If transmitting antenna directional gain is greater than 6 dBi, both the peak transmit power and the peak power spectral density shall be reduced by the amount in dB that the directional gain of the antenna exceeds 6 dBi.

3.7.2 Antenna Anti-Replacement Construction

An embedded-in antenna design is used.

3.7.3 Antenna Gain

<CDD Modes >

FCC KDB 662911 D01 Multiple Transmitter Output v02r01

For CDD transmissions, directional gain is calculated as

Directional gain = GANT + Array Gain, where Array Gain is as follows.

For power spectral density (PSD) measurements on all devices,

Array Gain = 10 log(NANT/NSS=1) dB.

For power measurements on IEEE 802.11 devices,

Array Gain = 0 dB (i.e., no array gain) for NANT ≤ 4.

Directional gain may be calculated by using the formulas applicable to equal gain antennas with GANT set equal to the gain of the antenna having the highest gain;

The EUT supports CDD mode.

For power, the directional gain GANT is set equal to the antenna having the highest gain, i.e., F)2)f)i).

For PSD, the directional gain calculation is following F)2)f)ii) of KDB 662911 D01 v02r01.

The power and PSD limit should be modified if the directional gain of EUT is over 6 dBi,

The directional gain "DG" is calculated as following table.

<CDD Modes>						
			DG for Power (dBi)	DG for PSD (dBi)	Power Limit Reduction (dB)	PSD Limit Reduction (dB)
	Ant. 1 (dBi)	Ant. 2 (dBi)				
Band I	1.90	1.90	1.90	4.91	0.00	0.00
Band II	1.90	1.80	1.90	4.86	0.00	0.00
Band III	1.70	1.70	1.70	4.71	0.00	0.00

Power limit reduction = Composite gain – 6dBi, (min = 0)

PSD limit reduction = Composite gain + PSD Array gain – 6dBi, (min = 0)



4 List of Measuring Equipment

Instrument	Manufacturer	Model No.	Serial No.	Characteristics	Calibration Date	Test Date	Due Date	Remark
Spectrum Analyzer	Keysight	N9010A	MY560704 12	10Hz~7GHz	Aug. 16, 2018	Jul. 06, 2019	Aug. 15, 2019	DFS (DFS02-HY)
Loop Antenna	Rohde & Schwarz	HFH2-Z2	100488	9 kHz~30 MHz	Jan. 07, 2019	Jun. 28, 2019~ Jul. 03, 2019	Jan. 06, 2020	Radiation (03CH12-HY)
Bilog Antenna	TESEQ	CBL 6111D&00800 N1D01N-06	37059&01	30MHz~1GHz	Oct. 13, 2018	Jun. 28, 2019~ Jul. 03, 2019	Oct. 12, 2019	Radiation (03CH12-HY)
Horn Antenna	SCHWARZBE CK	BBHA 9120D	9120D-132 8	1GHz ~ 18GHz	Nov. 09, 2018	Jun. 28, 2019~ Jul. 03, 2019	Nov. 08, 2019	Radiation (03CH12-HY)
SHF-EHF Horn Antenna	SCHWARZBE CK	BBHA 9170	BBHA9170 584	18GHz ~ 40GHz	Dec. 05, 2018	Jun. 28, 2019~ Jul. 03, 2019	Dec. 04, 2019	Radiation (03CH12-HY)
Preamplifier	COM-POWER	PA-103	161075	10MHz~1GHz	Mar. 25, 2019	Jun. 28, 2019~ Jul. 03, 2019	Mar. 24, 2020	Radiation (03CH12-HY)
Preamplifier	Agilent	8449B	3008A023 75	1GHz~26.5GHz	May 27, 2019	Jun. 28, 2019~ Jul. 03, 2019	May 26, 2020	Radiation (03CH12-HY)
Preamplifier	MITEQ	AMF-7D-0010 1800-30-10P	1590074	1GHz~18GHz	May 20, 2019	Jun. 28, 2019~ Jul. 03, 2019	May 19, 2020	Radiation (03CH12-HY)
Preamplifier	EMEC	EM18G40G	060715	18GHz ~ 40GHz	Dec. 06, 2018	Jun. 28, 2019~ Jul. 03, 2019	Dec. 05, 2019	Radiation (03CH12-HY)
EMI Test Receiver	Rohde & Schwarz	ESU26	100390	20Hz~26.5GHz	Dec. 26, 2018	Jun. 28, 2019~ Jul. 03, 2019	Dec. 25, 2019	Radiation (03CH12-HY)
Spectrum Analyzer	Keysight	N9010A	MY553705 26	10Hz~44GHz	Mar. 19, 2019	Jun. 28, 2019~ Jul. 03, 2019	Mar. 18, 2020	Radiation (03CH12-HY)
Filter	Wainwright	WLK4-1000-1 530-6000-40S S	SN11	1 GHz Lowpass	Sep. 16, 2018	Jun. 28, 2019~ Jul. 03, 2019	Sep. 15, 2019	Radiation (03CH12-HY)
Filter	Woken	WHKX8-5272. 5-6750-18000 -40ST	SN2	6.75G Highpass	Sep. 17, 2018	Jun. 28, 2019~ Jul. 03, 2019	Sep.16, 2019	Radiation (03CH12-HY)
RF Cable	HUBER + SUHNER	SUCOFLEX 126E	0058/126E	30M-18G	Mar. 13, 2019	Jun. 28, 2019~ Jul. 03, 2019	Mar. 12, 2020	Radiation (03CH12-HY)
RF Cable	HUBER + SUHNER	SUCOFLEX 102	505134/2	30M~40GHz	Oct. 16, 2018	Jun. 28, 2019~ Jul. 03, 2019	Oct. 15, 2019	Radiation (03CH12-HY)
RF Cable	HUBER + SUHNER	SUCOFLEX 102	800740/2	30M~40GHz	Oct. 16, 2018	Jun. 28, 2019~ Jul. 03, 2019	Oct. 15, 2019	Radiation (03CH12-HY)
Antenna Mast	EMEC	AM-BS-4500- B	N/A	1m~4m	N/A	Jun. 28, 2019~ Jul. 03, 2019	N/A	Radiation (03CH12-HY)
Turn Table	EMEC	TT2000	N/A	0~360 Degree	N/A	Jun. 28, 2019~ Jul. 03, 2019	N/A	Radiation (03CH12-HY)
Software	Audix	E3 6.2009-8-24	RK-00098 9	N/A	N/A	Jun. 28, 2019~ Jul. 03, 2019	N/A	Radiation (03CH12-HY)



Instrument	Manufacturer	Model No.	Serial No.	Characteristics	Calibration Date	Test Date	Due Date	Remark
Power Sensor	DARE	RPR3006W	13I00030S NO32	9kHz~6GHz	Dec. 03, 2018	Jun.10 2019~ Jul. 09 2019	Dec. 02, 2019	Conducted (TH05-HY)
Spectrum Analyzer	Rohde & Schwarz	FSP40	100057	9kHz~40GHz	Nov. 21, 2018	Jun.10 2019~ Jul. 09 2019	Nov. 20, 2019	Conducted (TH05-HY)
Switch Box & RF Cable	Burgeon	ETF-058	EC120838 2	N/A	Mar. 27, 2019	Jun.10 2019~ Jul. 09 2019	Mar. 26, 2020	Conducted (TH05-HY)
AC Power Source	ChainTek	APC-1000W	N/A	N/A	N/A	Jul. 01, 2019	N/A	Conduction (CO05-HY)
EMI Test Receiver	Rohde & Schwarz	ESR3	102388	9kHz~3.6GHz	Nov. 12, 2018	Jul. 01, 2019	Nov. 11, 2019	Conduction (CO05-HY)
LISN	Rohde & Schwarz	ENV216	100080	9kHz~30MHz	Nov. 14, 2018	Jul. 01, 2019	Nov. 13, 2019	Conduction (CO05-HY)
LISN	Rohde & Schwarz	ENV216	100081	9kHz~30MHz	Nov. 09, 2018	Jul. 01, 2019	Nov. 08, 2019	Conduction (CO05-HY)
Software	Rohde & Schwarz	EMC32 V10.30	N/A	N/A	N/A	Jul. 01, 2019	N/A	Conduction (CO05-HY)
LF Cable	HUBER + SUHNER	RG-214/U	LF01	N/A	Dec. 31, 2018	Jul. 01, 2019	Dec. 30, 2019	Conduction (CO05-HY)
Pulse Limiter	Rohde & Schwarz	ESH3-Z2	100851	N/A	Dec. 31, 2018	Jul. 01, 2019	Dec. 30, 2019	Conduction (CO05-HY)



5 Uncertainty of Evaluation

Uncertainty of Conducted Emission Measurement (150kHz ~ 30MHz)

Measuring Uncertainty for a Level of Confidence of 95% ($U = 2Uc(y)$)	2.20
---	------

Uncertainty of Radiated Emission Measurement (30 MHz ~ 1000 MHz)

Measuring Uncertainty for a Level of Confidence of 95% ($U = 2Uc(y)$)	5.10
---	------

Uncertainty of Radiated Emission Measurement (1000 MHz ~ 18000 MHz)

Measuring Uncertainty for a Level of Confidence of 95% ($U = 2Uc(y)$)	5.20
---	------

Uncertainty of Radiated Emission Measurement (18000 MHz ~ 40000 MHz)

Measuring Uncertainty for a Level of Confidence of 95% ($U = 2Uc(y)$)	4.70
---	------

Appendix A. Test Result of Conducted Test Items

Test Engineer:	Richard Qiu	Temperature:	21~25	°C
Test Date:	2019/6/10~2019/7/09	Relative Humidity:	51~54	%

TEST RESULTS DATA
26dB and 99% OBW

Band I													
Mod.	Data Rate	NTX	CH.	Freq. (MHz)	99% Bandwidth (MHz)		26 dB Bandwidth (MHz)		IC 99% Bandwidth Power Limit (dBm)		IC 99% Bandwidth EIRP Limit (dBm)		Note
					Ant 1	Ant 2	Ant 1	Ant 2	Ant 1	Ant 2	Ant 1	Ant 2	
11a	6Mbps	2	36	5180	16.65	16.65	24.10	23.85	-	-	22.21	22.21	
11a	6Mbps	2	44	5220	16.70	16.65	23.90	23.50	-	-	22.21	22.21	
11a	6Mbps	2	48	5240	16.70	16.65	24.50	24.65	-	-	22.21	22.21	
VHT20	MCS0	2	36	5180	17.80	17.85	25.20	24.70	-	-	22.50	22.50	
VHT20	MCS0	2	44	5220	17.85	17.85	25.15	24.60	-	-	22.52	22.52	
VHT20	MCS0	2	48	5240	17.85	17.80	24.75	25.25	-	-	22.50	22.50	
VHT40	MCS0	2	38	5190	36.60	36.70	41.76	42.24	-	-	23.01	23.01	
VHT40	MCS0	2	46	5230	36.60	36.60	42.06	42.12	-	-	23.01	23.01	
VHT80	MCS0	2	42	5210	76.68	76.80	83.84	83.84	-	-	23.01	23.01	

TEST RESULTS DATA
Average Power Table

FCC Band I												
Mod.	Data Rate	NTX	CH.	Freq. (MHz)	Average Conducted Power (dBm)			FCC Conducted Power Limit (dBm)		DG (dBi)		Pass/Fail
					Ant 1	Ant 2	SUM	Ant 1	Ant 2	Ant 1	Ant 2	
11a	6Mbps	1	36	5180	16.80	16.80		24.00	24.00	1.90	1.90	Pass
11a	6Mbps	1	44	5220	16.90	16.60		24.00	24.00	1.90	1.90	Pass
11a	6Mbps	1	48	5240	17.40	17.10		24.00	24.00	1.90	1.90	Pass
HT20	MCS0	1	36	5180	16.50	16.50		24.00	24.00	1.90	1.90	Pass
HT20	MCS0	1	44	5220	16.80	16.60		24.00	24.00	1.90	1.90	Pass
HT20	MCS0	1	48	5240	17.10	16.70		24.00	24.00	1.90	1.90	Pass
HT40	MCS0	1	38	5190	12.80	12.90		24.00	24.00	1.90	1.90	Pass
HT40	MCS0	1	46	5230	12.80	12.70		24.00	24.00	1.90	1.90	Pass
VHT20	MCS0	1	36	5180	16.60	16.60		24.00	24.00	1.90	1.90	Pass
VHT20	MCS0	1	44	5220	16.90	16.70		24.00	24.00	1.90	1.90	Pass
VHT20	MCS0	1	48	5240	17.20	16.80		24.00	24.00	1.90	1.90	Pass
VHT40	MCS0	1	38	5190	12.90	13.00		24.00	24.00	1.90	1.90	Pass
VHT40	MCS0	1	46	5230	12.90	12.80		24.00	24.00	1.90	1.90	Pass
VHT80	MCS0	1	42	5210	11.00	10.60		24.00	24.00	1.90	1.90	Pass
11a	6Mbps	2	36	5180	16.90	16.90	19.91	24.00		1.90		Pass
11a	6Mbps	2	44	5220	17.00	16.70	19.86	24.00		1.90		Pass
11a	6Mbps	2	48	5240	17.50	17.20	20.36	24.00		1.90		Pass
HT20	MCS0	2	36	5180	16.60	16.60	19.61	24.00		1.90		Pass
HT20	MCS0	2	44	5220	16.90	16.70	19.81	24.00		1.90		Pass
HT20	MCS0	2	48	5240	17.20	16.80	20.01	24.00		1.90		Pass
HT40	MCS0	2	38	5190	12.90	13.00	15.96	24.00		1.90		Pass
HT40	MCS0	2	46	5230	12.90	12.80	15.86	24.00		1.90		Pass
VHT20	MCS0	2	36	5180	16.70	16.70	19.71	24.00		1.90		Pass
VHT20	MCS0	2	44	5220	17.00	16.80	19.91	24.00		1.90		Pass
VHT20	MCS0	2	48	5240	17.30	16.90	20.11	24.00		1.90		Pass
VHT40	MCS0	2	38	5190	13.00	13.10	16.06	24.00		1.90		Pass
VHT40	MCS0	2	46	5230	13.00	12.90	15.96	24.00		1.90		Pass
VHT80	MCS0	2	42	5210	11.10	10.70	13.91	24.00		1.90		Pass

TEST RESULTS DATA
Power Spectral Density

FCC Band I														
Mod.	Data Rate	NTX	CH.	Freq. (MHz)	Duty Factor (dB)		Average Power Density (dBm/MHz)			Average PSD Limit (dBm/MHz)		DG (dBi)		Pass /Fail
					Ant 1	Ant 2	Ant 1	Ant 2	SUM	Ant 1	Ant 2	Ant 1	Ant 2	
11a	6Mbps	2	36	5180	0.00	0.00			10.81	11.00		4.91		Pass
11a	6Mbps	2	44	5220	0.00	0.00			10.87	11.00		4.91		Pass
11a	6Mbps	2	48	5240	0.00	0.00			10.83	11.00		4.91		Pass
VHT20	MCS0	2	36	5180	0.00	0.00			10.61	11.00		4.91		Pass
VHT20	MCS0	2	44	5220	0.00	0.00			10.75	11.00		4.91		Pass
VHT20	MCS0	2	48	5240	0.00	0.00			10.93	11.00		4.91		Pass
VHT40	MCS0	2	38	5190	0.00	0.00			3.22	11.00		4.91		Pass
VHT40	MCS0	2	46	5230	0.00	0.00			3.53	11.00		4.91		Pass
VHT80	MCS0	2	42	5210	0.00	0.00			-0.83	11.00		4.91		Pass

TEST RESULTS DATA
26dB and 99% OBW

Band II															
Mod.	Data Rate	NTX	CH.	Freq. (MHz)	99% Bandwidth (MHz)		26 dB Bandwidth (MHz)		IC 99% Bandwidth Power Limit (dBm)		IC 99% Bandwidth EIRP Limit (dBm)		FCC 26dB Bandwidth Power Limit (dBm)		Note
					Ant 1	Ant 2	Ant 1	Ant 2	Ant 1	Ant 2	Ant 1	Ant 2	Ant 1	Ant 2	
11a	6Mbps	2	52	5260	16.65	16.65	23.75	23.45	23.21		29.21		23.98		
11a	6Mbps	2	60	5300	16.70	16.65	23.35	23.90	23.21		29.21		23.98		
11a	6Mbps	2	64	5320	16.65	16.60	23.65	24.55	23.20		29.20		23.98		
VHT20	MCS0	2	52	5260	17.85	17.75	24.80	24.60	23.49		29.49		23.98		
VHT20	MCS0	2	60	5300	17.85	17.80	25.50	24.85	23.50		29.50		23.98		
VHT20	MCS0	2	64	5320	17.90	17.85	26.30	24.60	23.52		29.52		23.98		
VHT40	MCS0	2	54	5270	36.70	36.80	42.25	42.35	23.98		30.00		23.98		
VHT40	MCS0	2	62	5310	36.60	36.60	42.12	41.94	23.98		30.00		23.98		
VHT80	MCS0	2	58	5290	76.68	76.68	84.48	84.05	23.98		30.00		23.98		

TEST RESULTS DATA
Average Power Table

FCC Band II													
Mod.	Data Rate	N _{Tx}	CH.	Freq. (MHz)	Average Conducted Power (dBm)			FCC Conducted Power Limit (dBm)		DG (dBi)		EIRP Power Limit (dBm)	Pass/Fail
					Ant 1	Ant 2	SUM	Ant 1	Ant 2	Ant 1	Ant 2		
11a	6Mbps	1	52	5260	16.70	16.20		-	-	1.90	1.80	26.99	Pass
11a	6Mbps	1	60	5300	16.80	16.20		-	-	1.90	1.80	26.99	Pass
11a	6Mbps	1	64	5320	16.90	15.90		-	-	1.90	1.80	26.99	Pass
HT20	MCS0	1	52	5260	17.20	16.50		-	-	1.90	1.80	26.99	Pass
HT20	MCS0	1	60	5300	17.50	16.50		-	-	1.90	1.80	26.99	Pass
HT20	MCS0	1	64	5320	17.50	16.30		-	-	1.90	1.80	26.99	Pass
HT40	MCS0	1	54	5270	14.50	13.80		-	-	1.90	1.80	26.99	Pass
HT40	MCS0	1	62	5310	14.30	13.60		-	-	1.90	1.80	26.99	Pass
VHT20	MCS0	1	52	5260	17.30	16.60		-	-	1.90	1.80	26.99	Pass
VHT20	MCS0	1	60	5300	17.60	16.60		-	-	1.90	1.80	26.99	Pass
VHT20	MCS0	1	64	5320	17.60	16.40		-	-	1.90	1.80	26.99	Pass
VHT40	MCS0	1	54	5270	14.60	13.90		-	-	1.90	1.80	26.99	Pass
VHT40	MCS0	1	62	5310	14.40	13.70		-	-	1.90	1.80	26.99	Pass
VHT80	MCS0	1	58	5290	10.80	10.10		-	-	1.90	1.80	26.99	Pass
11a	6Mbps	2	52	5260	16.80	16.30	19.57	23.98		1.90		26.99	Pass
11a	6Mbps	2	60	5300	16.90	16.30	19.62	23.98		1.90		26.99	Pass
11a	6Mbps	2	64	5320	17.00	16.00	19.54	23.98		1.90		26.99	Pass
HT20	MCS0	2	52	5260	17.30	16.60	19.97	23.98		1.90		26.99	Pass
HT20	MCS0	2	60	5300	17.60	16.60	20.14	23.98		1.90		26.99	Pass
HT20	MCS0	2	64	5320	17.60	16.40	20.05	23.98		1.90		26.99	Pass
HT40	MCS0	2	54	5270	14.60	13.90	17.27	23.98		1.90		26.99	Pass
HT40	MCS0	2	62	5310	14.40	13.70	17.07	-		1.90		26.99	Pass
VHT20	MCS0	2	52	5260	17.40	16.70	20.07	23.98		1.90		26.99	Pass
VHT20	MCS0	2	60	5300	17.70	16.70	20.24	23.98		1.90		26.99	Pass
VHT20	MCS0	2	64	5320	17.70	16.50	20.15	23.98		1.90		26.99	Pass
VHT40	MCS0	2	54	5270	14.70	14.00	17.37	23.98		1.90		26.99	Pass
VHT40	MCS0	2	62	5310	14.50	13.80	17.17	23.98		1.90		26.99	Pass
VHT80	MCS0	2	58	5290	11.40	10.60	14.03	23.98		1.90		26.99	Pass

TEST RESULTS DATA
Power Spectral Density

Band II														
Mod.	Data Rate	NTX	CH.	Freq. (MHz)	Duty Factor (dB)		Average Power Density (dBm/MHz)			Average PSD Limit (dBm/MHz)		DG (dBi)		Pass /Fail
					Ant 1	Ant 2	Ant 1	Ant 2	SUM	Ant 1	Ant 2	Ant 1	Ant 2	
11a	6Mbps	2	52	5260	0.00	0.00			10.66	11.00		4.86		Pass
11a	6Mbps	2	60	5300	0.00	0.00			10.57	11.00		4.86		Pass
11a	6Mbps	2	64	5320	0.00	0.00			10.27	11.00		4.86		Pass
VHT20	MCS0	2	52	5260	0.00	0.00			10.93	11.00		4.86		Pass
VHT20	MCS0	2	60	5300	0.00	0.00			10.88	11.00		4.86		Pass
VHT20	MCS0	2	64	5320	0.00	0.00			10.84	11.00		4.86		Pass
VHT40	MCS0	2	54	5270	0.00	0.00			4.75	11.00		4.86		Pass
VHT40	MCS0	2	62	5310	0.00	0.00			4.02	11.00		4.86		Pass
VHT80	MCS0	2	58	5290	0.00	0.00			-1.10	11.00		4.86		Pass

TEST RESULTS DATA
26dB and 99% OBW

Band III																
Mod.	Data Rate	NTX	CH.	Freq. (MHz)	99% Bandwidth In U-NII 2C (MHz)		26 dB Bandwidth In U-NII 2C (MHz)		IC 99% Bandwidth Power Limit (dBm)		IC 99% Bandwidth EIRP Limit (dBm)		FCC 26dB Bandwidth Power Limit (dBm)		6 dB Bandwidth for Straddle Channel (MHz)	
					Ant 1	Ant 2	Ant 1	Ant 2	Ant 1	Ant 2	Ant 1	Ant 2	Ant 1	Ant 2	Ant 1	Ant 2
11a	6Mbps	2	100	5500	16.70	16.60	23.85	24.05	23.20	29.20	23.98	----	----			
11a	6Mbps	2	116	5580	16.70	16.60	24.35	24.65	23.20	29.20	23.98	----	----			
11a	6Mbps	2	140	5700	16.70	16.60	24.55	23.60	23.20	29.20	23.98	----	----			
11a	6Mbps	2	144	5720	13.35	13.40	17.40	17.20	22.25	28.25	23.36	2.5	2.45			
VHT20	MCS0	2	100	5500	17.85	17.80	25.95	25.40	23.50	29.50	23.98	----	----			
VHT20	MCS0	2	116	5580	17.90	17.80	25.45	25.05	23.50	29.50	23.98	----	----			
VHT20	MCS0	2	140	5700	17.85	17.90	23.90	25.35	23.52	29.52	23.98	----	----			
VHT20	MCS0	2	144	5720	14.00	14.00	17.75	17.45	22.46	28.46	23.42	----	3.1			
VHT40	MCS0	2	102	5510	36.60	36.60	42.48	42.26	23.98	30.00	23.98	----	----			
VHT40	MCS0	2	110	5550	36.60	36.60	42.24	42.12	23.98	30.00	23.98	----	----			
VHT40	MCS0	2	134	5670	36.60	36.70	42.07	41.87	23.98	30.00	23.98	----	----			
VHT40	MCS0	2	142	5710	33.30	33.30	35.97	35.88	23.98	30.00	23.98	2.7	2.5			
VHT80	MCS0	2	106	5530	76.80	76.68	83.84	83.52	23.98	30.00	23.98	----	----			
VHT80	MCS0	2	122	5610	76.68	76.68	84.80	83.97	23.98	30.00	23.98	----	----			
VHT80	MCS0	2	138	5690	73.52	73.40	77.00	76.60	23.98	30.00	23.98	2.6	2.5			

TEST RESULTS DATA
Average Power Table

FCC Band III													
Mod.	Data Rate	N _{Tx}	CH.	Freq. (MHz)	Average Conducted Power (dBm)			FCC Conducted Power Limit (dBm)		DG (dBi)		EIRP Power Limit (dBm)	Pass/Fail
					Ant 1	Ant 2	SUM	Ant 1	Ant 2	Ant 1	Ant 2		
11a	6Mbps	1	100	5500	16.90	16.50		-	-	1.70	1.70	26.99	Pass
11a	6Mbps	1	116	5580	16.80	16.20		-	-	1.70	1.70	26.99	Pass
11a	6Mbps	1	140	5700	16.60	15.80		-	-	1.70	1.70	26.99	Pass
11a	6Mbps	1	144	5720	16.70	16.00		-	-	1.70	1.70	26.99	Pass
HT20	MCS0	1	100	5500	17.00	16.00		-	-	1.70	1.70	26.99	Pass
HT20	MCS0	1	116	5580	16.70	15.80		-	-	1.70	1.70	26.99	Pass
HT20	MCS0	1	140	5700	16.80	16.00		-	-	1.70	1.70	26.99	Pass
HT20	MCS0	1	144	5720	17.00	16.00		-	-	1.70	1.70	26.99	Pass
HT40	MCS0	1	102	5510	17.80	17.50		-	-	1.70	1.70	26.99	Pass
HT40	MCS0	1	110	5550	18.30	17.90		-	-	1.70	1.70	26.99	Pass
HT40	MCS0	1	134	5670	17.60	17.10		-	-	1.70	1.70	26.99	Pass
HT40	MCS0	1	142	5710	18.10	17.50		-	-	1.70	1.70	26.99	Pass
VHT20	MCS0	1	100	5500	17.10	16.10		-	-	1.70	1.70	26.99	Pass
VHT20	MCS0	1	116	5580	16.80	15.90		-	-	1.70	1.70	26.99	Pass
VHT20	MCS0	1	140	5700	16.90	16.10		-	-	1.70	1.70	26.99	Pass
VHT20	MCS0	1	144	5720	17.10	16.10		-	-	1.70	1.70	26.99	Pass
VHT40	MCS0	1	102	5510	17.90	17.60		-	-	1.70	1.70	26.99	Pass
VHT40	MCS0	1	110	5550	18.40	18.00		-	-	1.70	1.70	26.99	Pass
VHT40	MCS0	1	134	5670	17.70	17.20		-	-	1.70	1.70	26.99	Pass
VHT40	MCS0	1	142	5710	18.20	17.60		-	-	1.70	1.70	26.99	Pass
VHT80	MCS0	1	106	5530	12.80	12.30		-	-	1.70	1.70	26.99	Pass
VHT80	MCS0	1	122	5610	19.20	18.50		-	-	1.70	1.70	26.99	Pass
VHT80	MCS0	1	138	5690	12.90	12.10		-	-	1.70	1.70	26.99	Pass
11a	6Mbps	2	100	5500	17.00	16.60	19.81	23.98		1.70		26.99	Pass
11a	6Mbps	2	116	5580	16.90	16.30	19.62	23.98		1.70		26.99	Pass
11a	6Mbps	2	140	5700	16.70	15.90	19.33	23.98		1.70		26.99	Pass
11a	6Mbps	2	144	5720	16.80	16.10	19.47	23.36		1.70		26.99	Pass
HT20	MCS0	2	100	5500	17.10	16.10	19.64	23.98		1.70		26.99	Pass
HT20	MCS0	2	116	5580	16.80	15.90	19.38	23.98		1.70		26.99	Pass
HT20	MCS0	2	140	5700	16.90	16.10	19.53	23.98		1.70		26.99	Pass
HT20	MCS0	2	144	5720	17.10	16.10	19.64	23.42		1.70		26.99	Pass
HT40	MCS0	2	102	5510	17.90	17.60	20.76	23.98		1.70		26.99	Pass
HT40	MCS0	2	110	5550	18.40	18.00	21.21	23.98		1.70		26.99	Pass
HT40	MCS0	2	134	5670	17.70	17.20	20.47	23.98		1.70		26.99	Pass
HT40	MCS0	2	142	5710	18.20	17.60	20.92	23.98		1.70		26.99	Pass
VHT20	MCS0	2	100	5500	17.20	16.20	19.74	23.98		1.70		26.99	Pass
VHT20	MCS0	2	116	5580	16.90	16.00	19.48	23.98		1.70		26.99	Pass
VHT20	MCS0	2	140	5700	17.00	16.20	19.63	23.98		1.70		26.99	Pass
VHT20	MCS0	2	144	5720	17.20	16.20	19.74	23.42		1.70		26.99	Pass
VHT40	MCS0	2	102	5510	18.00	17.70	20.86	23.98		1.70		26.99	Pass
VHT40	MCS0	2	110	5550	18.50	18.10	21.31	23.98		1.70		26.99	Pass
VHT40	MCS0	2	134	5670	17.80	17.30	20.57	23.98		1.70		26.99	Pass
VHT40	MCS0	2	142	5710	18.30	17.70	21.02	23.98		1.70		26.99	Pass
VHT80	MCS0	2	106	5530	13.70	13.40	16.56	23.98		1.70		26.99	Pass
VHT80	MCS0	2	122	5610	19.30	18.60	21.97	23.98		1.70		26.99	Pass
VHT80	MCS0	2	138	5690	13.00	12.20	15.63	23.98		1.70		26.99	Pass

TEST RESULTS DATA
Power Spectral Density

Band III														
Mod.	Data Rate	NTX	CH.	Freq. (MHz)	Duty Factor (dB)		Average Power Density (dBm/MHz)			Average PSD Limit (dBm/MHz)		DG (dBi)		Pass /Fail
					Ant 1	Ant 2	Ant 1	Ant 2	SUM	Ant 1	Ant 2	Ant 1	Ant 2	
11a	6Mbps	2	100	5500	0.00	0.00			10.78	11.00	4.71		Pass	
11a	6Mbps	2	116	5580	0.00	0.00			10.80	11.00	4.71		Pass	
11a	6Mbps	2	140	5700	0.00	0.00			10.36	11.00	4.71		Pass	
11a	6Mbps	2	144	5720	0.00	0.00			10.29	11.00	4.71		Pass	
VHT20	MCS0	2	100	5500	0.00	0.00			10.91	11.00	4.71		Pass	
VHT20	MCS0	2	116	5580	0.00	0.00			10.93	11.00	4.71		Pass	
VHT20	MCS0	2	140	5700	0.00	0.00			10.97	11.00	4.71		Pass	
VHT20	MCS0	2	144	5720	0.00	0.00			10.92	11.00	4.71		Pass	
VHT40	MCS0	2	102	5510	0.00	0.00			8.17	11.00	4.71		Pass	
VHT40	MCS0	2	110	5550	0.00	0.00			9.19	11.00	4.71		Pass	
VHT40	MCS0	2	134	5670	0.00	0.00			7.93	11.00	4.71		Pass	
VHT40	MCS0	2	142	5710	0.00	0.00			8.34	11.00	4.71		Pass	
VHT80	MCS0	2	106	5530	0.00	0.00			1.15	11.00	4.71		Pass	
VHT80	MCS0	2	122	5610	0.00	0.00			7.67	11.00	4.71		Pass	
VHT80	MCS0	2	138	5690	0.00	0.00			1.04	11.00	4.71		Pass	



Appendix B. AC Conducted Emission Test Results

Test Engineer :	Louis Chung	Temperature :	23~26°C
		Relative Humidity :	59.1~69.3%

EUT Information

Report NO : 952409
 Test Mode : Mode 1
 Test Voltage : 120Vac/60Hz
 Phase : Line

Full Spectrum

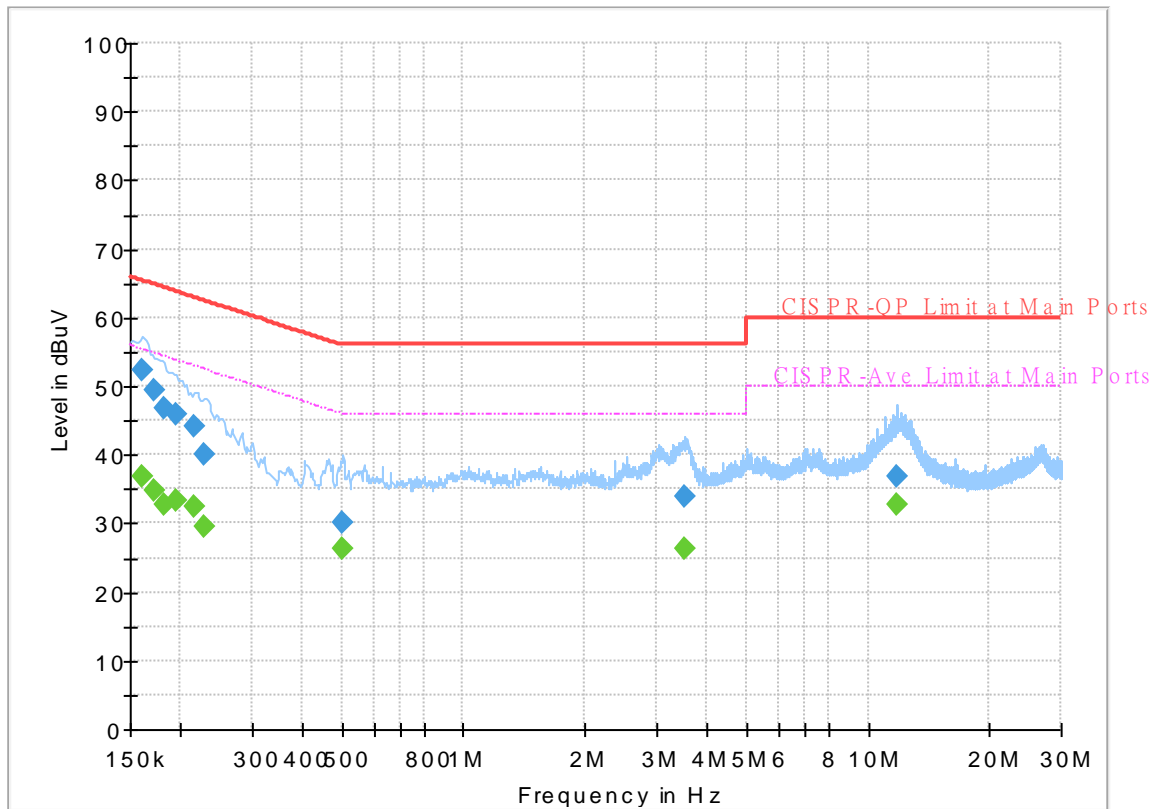

Final_Result

Frequency (MHz)	QuasiPeak (dBuV)	CAverage (dBuV)	Limit (dBuV)	Margin (dB)	Line	Filter	Corr. (dB)
0.161250	---	36.80	55.40	18.60	L1	OFF	19.4
0.161250	52.20	---	65.40	13.20	L1	OFF	19.4
0.172500	---	34.75	54.84	20.09	L1	OFF	19.4
0.172500	49.39	---	64.84	15.45	L1	OFF	19.4
0.181500	---	32.69	54.42	21.73	L1	OFF	19.4
0.181500	46.76	---	64.42	17.66	L1	OFF	19.4
0.195000	---	33.32	53.82	20.50	L1	OFF	19.4
0.195000	45.87	---	63.82	17.95	L1	OFF	19.4
0.215250	---	32.52	53.00	20.48	L1	OFF	19.4
0.215250	44.09	---	63.00	18.91	L1	OFF	19.4
0.228750	---	29.54	52.50	22.96	L1	OFF	19.4
0.228750	40.15	---	62.50	22.35	L1	OFF	19.4
0.503250	---	26.42	46.00	19.58	L1	OFF	19.4
0.503250	30.20	---	56.00	25.80	L1	OFF	19.4
3.538500	---	26.24	46.00	19.76	L1	OFF	19.6
3.538500	33.90	---	56.00	22.10	L1	OFF	19.6
11.845500	---	32.62	50.00	17.38	L1	OFF	19.9
11.845500	36.81	---	60.00	23.19	L1	OFF	19.9

EUT Information

Report NO : 952409
 Test Mode : Mode 1
 Test Voltage : 120Vac/60Hz
 Phase : Neutral

Full Spectrum

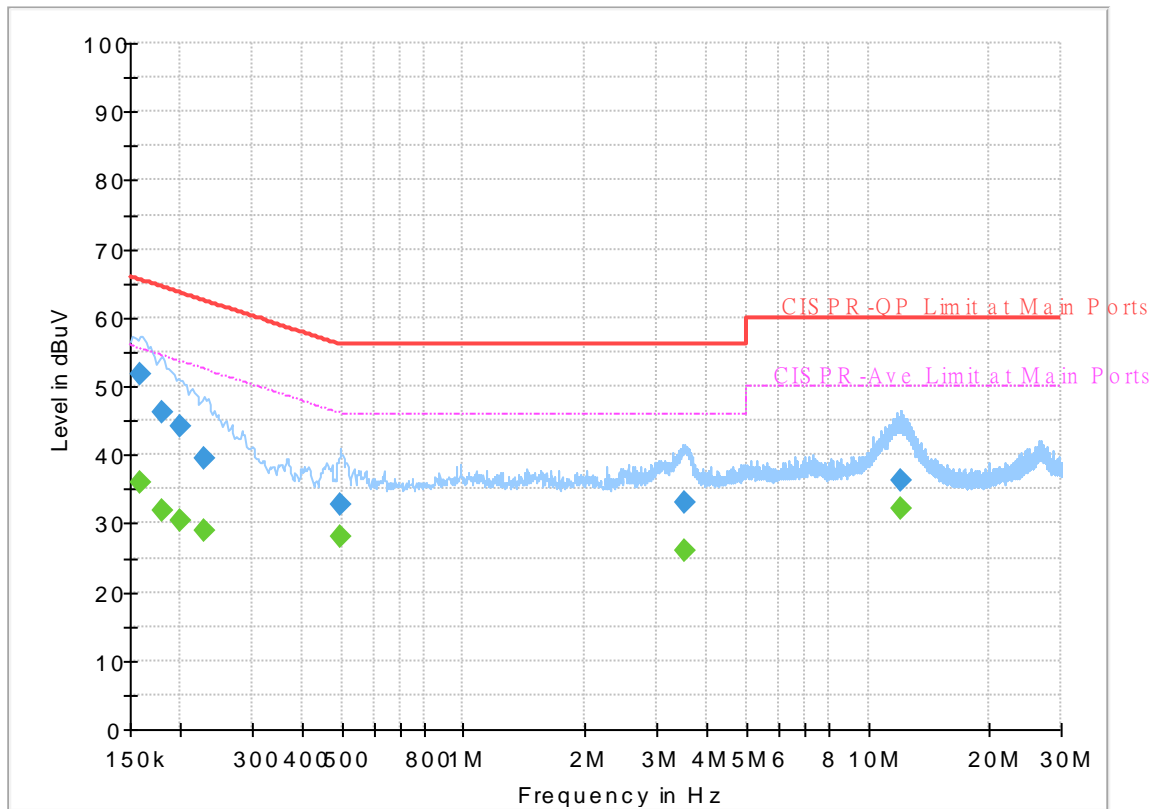

Final_Result

Frequency (MHz)	QuasiPeak (dBuV)	CAverage (dBuV)	Limit (dBuV)	Margin (dB)	Line	Filter	Corr. (dB)
0.159000	---	36.10	55.52	19.42	N	OFF	19.5
0.159000	51.67	---	65.52	13.85	N	OFF	19.5
0.179250	---	31.90	54.52	22.62	N	OFF	19.5
0.179250	46.28	---	64.52	18.24	N	OFF	19.5
0.199500	---	30.37	53.63	23.26	N	OFF	19.5
0.199500	44.09	---	63.63	19.54	N	OFF	19.5
0.228750	---	29.06	52.50	23.44	N	OFF	19.5
0.228750	39.62	---	62.50	22.88	N	OFF	19.5
0.496500	---	28.21	46.06	17.85	N	OFF	19.5
0.496500	32.75	---	56.06	23.31	N	OFF	19.5
3.507000	---	26.13	46.00	19.87	N	OFF	19.6
3.507000	32.90	---	56.00	23.10	N	OFF	19.6
12.012000	---	32.13	50.00	17.87	N	OFF	20.0
12.012000	36.17	---	60.00	23.83	N	OFF	20.0



Appendix C. Radiated Spurious Emission

Test Engineer :	Jack Cheng, Lance Chiang, Chuan Chu	Temperature :	21~24°C
		Relative Humidity :	56~68%

Band 1 - 5150~5250MHz
WIFI 802.11a (Band Edge @ 3m)

WIFI	Note	Frequency	Level	Over	Limit	Read	Antenna	Path	Preamp	Ant	Table	Peak	Pol.	
Ant.				Limit	Line	Level	Factor	Loss	Factor	Pos	Pos	Avg.		
1+2		(MHz)	(dBµV/m)	(dB)	(dBµV/m)	(dBµV)	(dB/m)	(dB)	(dB)	(cm)	(deg)	(P/A)	(H/V)	
802.11a CH 36 5180MHz		5143	54.07	-19.93	74	45.81	31.91	9.82	33.47	208	258	P	H	
		5150	47.05	-6.95	54	38.79	31.9	9.83	33.47	208	258	A	H	
	*	5180	112.96	-	-	104.77	31.78	9.87	33.46	208	258	P	H	
	*	5180	105.51	-	-	97.32	31.78	9.87	33.46	208	258	A	H	
													H	
														H
			5148.46	53.5	-20.5	74	45.24	31.9	9.83	33.47	227	60	P	V
			5149.24	45.64	-8.36	54	37.38	31.9	9.83	33.47	227	60	A	V
	*		5180	113.81	-	-	105.62	31.78	9.87	33.46	227	60	P	V
	*		5180	106.18	-	-	97.99	31.78	9.87	33.46	227	60	A	V
														V
														V
802.11a CH 44 5220MHz		5143	52.41	-21.59	74	44.15	31.91	9.82	33.47	190	252	P	H	
		5147.94	43.41	-10.59	54	35.16	31.9	9.82	33.47	190	252	A	H	
	*	5220	114.26	-	-	106.22	31.58	9.92	33.46	190	252	P	H	
	*	5220	106.21	-	-	98.17	31.58	9.92	33.46	190	252	A	H	
			5448.24	51.77	-22.23	74	43.3	31.69	10.22	33.44	190	252	P	H
			5452.72	44.06	-9.94	54	35.56	31.71	10.22	33.43	190	252	A	H
			5094.9	51.22	-22.78	74	42.96	31.98	9.75	33.47	100	68	P	V
			5149.24	43.47	-10.53	54	35.21	31.9	9.83	33.47	100	68	A	V
	*		5220	113.04	-	-	105	31.58	9.92	33.46	100	68	P	V
	*		5220	105.45	-	-	97.41	31.58	9.92	33.46	100	68	A	V
			5454.68	52.21	-21.79	74	43.69	31.72	10.23	33.43	100	68	P	V
			5452.72	44.83	-9.17	54	36.33	31.71	10.22	33.43	100	68	A	V



802.11a CH 48 5240MHz		5092.3	51.14	-22.86	74	42.9	31.97	9.74	33.47	194	252	P	H
		5143.26	42.96	-11.04	54	34.7	31.91	9.82	33.47	194	252	A	H
	*	5240	114.14	-	-	106.19	31.46	9.95	33.46	194	252	P	H
	*	5240	106.55	-	-	98.6	31.46	9.95	33.46	194	252	A	H
		5431.16	51.9	-22.1	74	43.53	31.62	10.19	33.44	194	252	P	H
		5356.68	43.81	-10.19	54	35.82	31.33	10.1	33.44	194	252	A	H
		5095.16	51.84	-22.16	74	43.58	31.98	9.75	33.47	206	36	P	V
		5145.34	42.61	-11.39	54	34.35	31.91	9.82	33.47	206	36	A	V
	*	5240	114.27	-	-	106.32	31.46	9.95	33.46	206	36	P	V
	*	5240	106.57	-	-	98.62	31.46	9.95	33.46	206	36	A	V
		5456.64	51.63	-22.37	74	43.1	31.73	10.23	33.43	206	36	P	V
		5375.72	44.02	-9.98	54	35.94	31.4	10.12	33.44	206	36	A	V
Remark	1. No other spurious found. 2. All results are PASS against Peak and Average limit line.												



Band 1 5150~5250MHz
WIFI 802.11a (Harmonic @ 3m)

WIFI Ant. 1+2	Note	Frequency (MHz)	Level (dBμV/m)	Over Limit (dB)	Limit Line (dBμV/m)	Read Level (dBμV)	Antenna Factor (dB/m)	Path Loss (dB)	Preamp Factor (dB)	Ant Pos (cm)	Table Pos (deg)	Peak Avg. (P/A)	Pol. (H/V)
802.11a CH 36 5180MHz		10360	46.96	-21.24	68.2	52.67	39.58	15.47	60.76	100	0	P	H
		15540	45.43	-28.57	74	49.42	38.22	19.34	61.55	100	0	P	H
													H
													H
		10360	48.35	-19.85	68.2	54.06	39.58	15.47	60.76	100	0	P	V
		15540	45.56	-28.44	74	49.55	38.22	19.34	61.55	100	0	P	V
													V
													V
802.11a CH 44 5220MHz		10440	48.21	-19.99	68.2	53.97	39.7	15.5	60.96	100	0	P	H
		15660	45.43	-28.57	74	49.62	37.8	19.42	61.41	100	0	P	H
													H
													H
		10440	45.71	-22.49	68.2	51.47	39.7	15.5	60.96	100	0	P	V
		15660	44.57	-29.43	74	48.76	37.8	19.42	61.41	100	0	P	V
													V
													V
802.11a CH 48 5240MHz		10480	47.76	-20.44	68.2	53.59	39.7	15.52	61.05	100	0	P	H
		15720	44.37	-29.63	74	48.5	37.76	19.45	61.34	100	0	P	H
													H
													H
		10480	47.22	-20.98	68.2	53.05	39.7	15.52	61.05	100	0	P	V
		15720	45.82	-28.18	74	49.95	37.76	19.45	61.34	100	0	P	V
													V
													V
Remark	1. No other spurious found. 2. All results are PASS against Peak and Average limit line.												



Band 1 5150~5250MHz
WIFI 802.11ac VHT20 (Band Edge @ 3m)

WIFI Ant. 1+2	Note	Frequency (MHz)	Level (dBμV/m)	Over Limit (dB)	Limit Line (dBμV/m)	Read Level (dBμV)	Antenna Factor (dB/m)	Path Loss (dB)	Preamp Factor (dB)	Ant Pos (cm)	Table Pos (deg)	Peak Avg. (P/A)	Pol. (H/V)	
802.11ac VHT20 CH 36 5180MHz		5149.24	56.72	-17.28	74	48.46	31.9	9.83	33.47	200	253	P	H	
		5149.76	48.72	-5.28	54	40.46	31.9	9.83	33.47	200	253	A	H	
	*	5180	114.29	-	-	106.1	31.78	9.87	33.46	200	253	P	H	
	*	5180	106.76	-	-	98.57	31.78	9.87	33.46	200	253	A	H	
													H	
														H
			5144.3	53.77	-20.23	74	45.51	31.91	9.82	33.47	200	35	P	V
			5148.98	45.73	-8.27	54	37.47	31.9	9.83	33.47	200	35	A	V
		*	5180	114	-	-	105.81	31.78	9.87	33.46	200	35	P	V
		*	5180	106.49	-	-	98.3	31.78	9.87	33.46	200	35	A	V
802.11ac VHT20 CH 44 5220MHz		5139.1	51.44	-22.56	74	43.18	31.92	9.81	33.47	208	252	P	H	
		5149.24	43.05	-10.95	54	34.79	31.9	9.83	33.47	208	252	A	H	
		* 5220	114.49	-	-	106.45	31.58	9.92	33.46	208	252	P	H	
		* 5220	107.22	-	-	99.18	31.58	9.92	33.46	208	252	A	H	
			5455.8	51.44	-22.56	74	42.92	31.72	10.23	33.43	208	252	P	H
			5451.32	43.43	-10.57	54	34.93	31.71	10.22	33.43	208	252	A	H
			5044.46	51.04	-22.96	74	43.09	31.76	9.67	33.48	185	87	P	V
			5150	43.28	-10.72	54	35.02	31.9	9.83	33.47	185	87	A	V
		*	5220	113.73	-	-	105.69	31.58	9.92	33.46	185	87	P	V
		*	5220	106.24	-	-	98.2	31.58	9.92	33.46	185	87	A	V
		5354.44	52.11	-21.89	74	44.14	31.32	10.09	33.44	185	87	P	V	
		5452.72	45.3	-8.7	54	36.8	31.71	10.22	33.43	185	87	A	V	



802.11ac VHT20 CH 48 5240MHz		5115.7	52.2	-21.8	74	43.92	31.97	9.78	33.47	183	250	P	H
		5149.76	42.89	-11.11	54	34.63	31.9	9.83	33.47	183	250	A	H
	*	5240	114.27	-	-	106.32	31.46	9.95	33.46	183	250	P	H
	*	5240	105.36	-	-	97.41	31.46	9.95	33.46	183	250	A	H
		5429.2	51.44	-22.56	74	43.07	31.62	10.19	33.44	183	250	P	H
		5355	43.63	-10.37	54	35.66	31.32	10.09	33.44	183	250	A	H
		5149.5	51.73	-22.27	74	43.47	31.9	9.83	33.47	209	62	P	V
		5149.5	42.91	-11.09	54	34.65	31.9	9.83	33.47	209	62	A	V
	*	5240	114.56	-	-	106.61	31.46	9.95	33.46	209	62	P	V
	*	5240	106.71	-	-	98.76	31.46	9.95	33.46	209	62	A	V
		5358.08	53.37	-20.63	74	45.38	31.33	10.1	33.44	209	62	P	V
		5376	44.85	-9.15	54	36.77	31.4	10.12	33.44	209	62	A	V
Remark	1. No other spurious found. 2. All results are PASS against Peak and Average limit line.												



Band 1 5150~5250MHz
WIFI 802.11ac VHT20 (Harmonic @ 3m)

WIFI Ant. 1+2	Note	Frequency (MHz)	Level (dBμV/m)	Over Limit (dB)	Limit Line (dBμV/m)	Read Level (dBμV)	Antenna Factor (dB/m)	Path Loss (dB)	Preamp Factor (dB)	Ant Pos (cm)	Table Pos (deg)	Peak Avg. (P/A)	Pol. (H/V)	
802.11ac VHT20 CH 36 5180MHz		10360	46.66	-21.54	68.2	52.37	39.58	15.47	60.76	100	0	P	H	
		15540	45.42	-28.58	74	49.41	38.22	19.34	61.55	100	0	P	H	
													H	
													H	
			10360	46.94	-21.26	68.2	52.65	39.58	15.47	60.76	100	0	P	V
			15540	45.31	-28.69	74	49.3	38.22	19.34	61.55	100	0	P	V
														V
802.11ac VHT20 CH 44 5220MHz		10440	48.07	-20.13	68.2	53.83	39.7	15.5	60.96	100	0	P	H	
		15660	45.22	-28.78	74	49.41	37.8	19.42	61.41	100	0	P	H	
													H	
													H	
			10440	47.47	-20.73	68.2	53.23	39.7	15.5	60.96	100	0	P	V
			15660	44.86	-29.14	74	49.05	37.8	19.42	61.41	100	0	P	V
														V
802.11ac VHT20 CH 48 5240MHz		10480	46.21	-21.99	68.2	52.04	39.7	15.52	61.05	100	0	P	H	
		15720	44.4	-29.6	74	48.53	37.76	19.45	61.34	100	0	P	H	
													H	
													H	
			10480	46.36	-21.84	68.2	52.19	39.7	15.52	61.05	100	0	P	V
			15720	45.03	-28.97	74	49.16	37.76	19.45	61.34	100	0	P	V
														V
Remark	1. No other spurious found.													
	2. All results are PASS against Peak and Average limit line.													



Band 1 5150~5250MHz
WIFI 802.11ac VHT40 (Band Edge @ 3m)

WIFI Ant. 1+2	Note	Frequency (MHz)	Level (dBμV/m)	Over Limit (dB)	Limit Line (dBμV/m)	Read Level (dBμV)	Antenna Factor (dB/m)	Path Loss (dB)	Preamp Factor (dB)	Ant Pos (cm)	Table Pos (deg)	Peak Avg. (P/A)	Pol. (H/V)
802.11ac VHT40 CH 38 5190MHz		5150	55.55	-18.45	74	47.29	31.9	9.83	33.47	198	252	P	H
		5147.94	49.05	-4.95	54	40.8	31.9	9.82	33.47	198	252	A	H
	*	5190	106.18	-	-	98.01	31.74	9.89	33.46	198	252	P	H
	*	5190	98.13	-	-	89.96	31.74	9.89	33.46	198	252	A	H
		5418.56	52.88	-21.12	74	44.57	31.57	10.18	33.44	198	252	P	H
		5412.4	45.72	-8.28	54	37.44	31.55	10.17	33.44	198	252	A	H
		5150	55.85	-18.15	74	47.59	31.9	9.83	33.47	221	40	P	V
		5147.42	49.18	-4.82	54	40.92	31.91	9.82	33.47	221	40	A	V
	*	5190	106.32	-	-	98.15	31.74	9.89	33.46	221	40	P	V
	*	5190	98.96	-	-	90.79	31.74	9.89	33.46	221	40	A	V
		5414.08	51.59	-22.41	74	43.3	31.56	10.17	33.44	221	40	P	V
		5412.12	46.92	-7.08	54	38.64	31.55	10.17	33.44	221	40	A	V
802.11ac VHT40 CH 46 5230MHz		5146.9	50.76	-23.24	74	42.5	31.91	9.82	33.47	202	256	P	H
		5148.2	43.21	-10.79	54	34.96	31.9	9.82	33.47	202	256	A	H
	*	5230	106.43	-	-	98.43	31.52	9.94	33.46	202	256	P	H
	*	5230	98.83	-	-	90.83	31.52	9.94	33.46	202	256	A	H
		5458.04	52.05	-21.95	74	43.52	31.73	10.23	33.43	202	256	P	H
		5452.44	46.89	-7.11	54	38.39	31.71	10.22	33.43	202	256	A	H
		5032.76	50.99	-23.01	74	43.15	31.66	9.66	33.48	203	36	P	V
		5149.5	43.28	-10.72	54	35.02	31.9	9.83	33.47	203	36	A	V
		5230	107.11	-	-	99.11	31.52	9.94	33.46	203	36	P	V
	*	5230	98.86	-	-	90.86	31.52	9.94	33.46	203	36	A	V
*	5454.4	54.23	-19.77	74	45.71	31.72	10.23	33.43	203	36	P	V	
	5452.72	48.54	-5.46	54	40.04	31.71	10.22	33.43	203	36	A	V	
Remark	1. No other spurious found. 2. All results are PASS against Peak and Average limit line.												



Band 1 5150~5250MHz
WIFI 802.11ac VHT40 (Harmonic @ 3m)

WIFI Ant. 1+2	Note	Frequency (MHz)	Level (dBμV/m)	Over Limit (dB)	Limit Line (dBμV/m)	Read Level (dBμV)	Antenna Factor (dB/m)	Path Loss (dB)	Preamp Factor (dB)	Ant Pos (cm)	Table Pos (deg)	Peak Avg. (P/A)	Pol. (H/V)	
802.11ac VHT40 CH 38 5190MHz		10380	45.11	-23.09	68.2	50.8	39.64	15.48	60.81	100	0	P	H	
		15570	44.25	-29.75	74	48.41	38.01	19.35	61.52	100	0	P	H	
													H	
													H	
			10380	45.45	-22.75	68.2	51.14	39.64	15.48	60.81	100	0	P	V
			15570	45.1	-28.9	74	49.26	38.01	19.35	61.52	100	0	P	V
														V
802.11ac VHT40 CH 46 5230MHz		10460	45.47	-22.73	68.2	51.26	39.7	15.51	61	100	0	P	H	
		15690	45.1	-28.9	74	49.24	37.8	19.43	61.37	100	0	P	H	
													H	
													H	
			10460	44.73	-23.47	68.2	50.52	39.7	15.51	61	100	0	P	V
			15690	44.62	-29.38	74	48.76	37.8	19.43	61.37	100	0	P	V
														V
Remark	1. No other spurious found.													
	2. All results are PASS against Peak and Average limit line.													



Band 1 5150~5250MHz
WIFI 802.11ac VHT80 (Band Edge @ 3m)

WIFI Ant. 1+2	Note	Frequency (MHz)	Level (dBμV/m)	Over Limit (dB)	Limit Line (dBμV/m)	Read Level (dBμV)	Antenna Factor (dB/m)	Path Loss (dB)	Preamp Factor (dB)	Ant Pos (cm)	Table Pos (deg)	Peak Avg. (P/A)	Pol. (H/V)
802.11ac VHT80 CH 42 5210MHz		5148.72	56.25	-17.75	74	47.99	31.9	9.83	33.47	190	252	P	H
		5149.76	48.35	-5.65	54	40.09	31.9	9.83	33.47	190	252	A	H
	*	5210	101.46	-	-	93.37	31.64	9.91	33.46	190	252	P	H
	*	5210	93.89	-	-	85.8	31.64	9.91	33.46	190	252	A	H
		5350.52	52.84	-21.16	74	44.89	31.3	10.09	33.44	190	252	P	H
		5448.8	43.36	-10.64	54	34.88	31.7	10.22	33.44	190	252	A	H
		5142.74	54.74	-19.26	74	46.48	31.91	9.82	33.47	213	63	P	V
		5147.68	47.41	-6.59	54	39.16	31.9	9.82	33.47	213	63	A	V
	*	5210	101.68	-	-	93.59	31.64	9.91	33.46	213	63	P	V
	*	5210	93.85	-	-	85.76	31.64	9.91	33.46	213	63	A	V
		5457.48	51.84	-22.16	74	43.31	31.73	10.23	33.43	213	63	P	V
		5452.72	45.88	-8.12	54	37.38	31.71	10.22	33.43	213	63	A	V
Remark	1. No other spurious found. 2. All results are PASS against Peak and Average limit line.												



**Band 1 5150~5250MHz
WIFI 802.11ac VHT80 (Harmonic @ 3m)**

WIFI Ant. 1+2	Note	Frequency (MHz)	Level (dBμV/m)	Over Limit (dB)	Limit Line (dBμV/m)	Read Level (dBμV)	Antenna Factor (dB/m)	Path Loss (dB)	Preamp Factor (dB)	Ant Pos (cm)	Table Pos (deg)	Peak Avg. (P/A)	Pol. (H/V)	
802.11ac VHT80 CH 42 5210MHz		10420	44.58	-23.62	68.2	50.29	39.7	15.5	60.91	100	0	P	H	
		15630	44.26	-29.74	74	48.51	37.8	19.39	61.44	100	0	P	H	
													H	
													H	
			10420	44.91	-23.29	68.2	50.62	39.7	15.5	60.91	100	0	P	V
			15630	46.04	-27.96	74	50.29	37.8	19.39	61.44	100	0	P	V
														V
														V
Remark	1. No other spurious found. 2. All results are PASS against Peak and Average limit line.													



Band 2 - 5250~5350MHz
WIFI 802.11a (Band Edge @ 3m)

WIFI	Note	Frequency	Level	Over	Limit	Read	Antenna	Path	Preamp	Ant	Table	Peak	Pol.
Ant.				Limit	Line	Level	Factor	Loss	Factor	Pos	Pos	Avg.	
1+2		(MHz)	(dBμV/m)	(dB)	(dBμV/m)	(dBμV)	(dB/m)	(dB)	(dB)	(cm)	(deg)	(P/A)	(H/V)
802.11a CH 52 5260MHz		5087.38	51.92	-22.08	74	43.7	31.95	9.74	33.47	195	251	P	H
		5136.68	42.31	-11.69	54	34.04	31.93	9.81	33.47	195	251	A	H
	*	5260	114.25	-	-	106.35	31.38	9.97	33.45	195	251	P	H
	*	5260	106.99	-	-	99.09	31.38	9.97	33.45	195	251	A	H
		5360.64	51.6	-22.4	74	43.6	31.34	10.1	33.44	195	251	P	H
		5358	43.2	-10.8	54	35.21	31.33	10.1	33.44	195	251	A	H
		5023.46	51.03	-22.97	74	43.28	31.59	9.64	33.48	208	86	P	V
		5119.34	42.3	-11.7	54	34.03	31.96	9.78	33.47	208	86	A	V
	*	5260	114.5	-	-	106.6	31.38	9.97	33.45	208	86	P	V
	*	5260	106.51	-	-	98.61	31.38	9.97	33.45	208	86	A	V
		5355.12	52.14	-21.86	74	44.17	31.32	10.09	33.44	208	86	P	V
		5376	44.41	-9.59	54	36.33	31.4	10.12	33.44	208	86	A	V
802.11a CH 60 5300MHz		5101.66	50.4	-23.6	74	42.11	32	9.76	33.47	188	252	P	H
		5148.92	42.39	-11.61	54	34.13	31.9	9.83	33.47	188	252	A	H
	*	5300	114.15	-	-	106.28	31.3	10.02	33.45	188	252	P	H
	*	5300	106.93	-	-	99.06	31.3	10.02	33.45	188	252	A	H
		5353.2	53.33	-20.67	74	45.37	31.31	10.09	33.44	188	252	P	H
		5350.8	45.72	-8.28	54	37.77	31.3	10.09	33.44	188	252	A	H
		5032.64	50.3	-23.7	74	42.46	31.66	9.66	33.48	206	62	P	V
		5147.56	42.42	-11.58	54	34.17	31.9	9.82	33.47	206	62	A	V
	*	5300	114.78	-	-	106.91	31.3	10.02	33.45	206	62	P	V
	*	5300	107.07	-	-	99.2	31.3	10.02	33.45	206	62	A	V
		5350.08	54.59	-19.41	74	46.64	31.3	10.09	33.44	206	62	P	V
		5350.08	46.99	-7.01	54	39.04	31.3	10.09	33.44	206	62	A	V



802.11a CH 64 5320MHz	*	5320	114.36	-	-	106.46	31.3	10.05	33.45	194	251	P	H
	*	5320	106.98	-	-	99.08	31.3	10.05	33.45	194	251	A	H
		5350.56	55.36	-18.64	74	47.41	31.3	10.09	33.44	194	251	P	H
		5350.08	47.64	-6.36	54	39.69	31.3	10.09	33.44	194	251	A	H
													H
													H
	*	5320	114.89	-	-	106.99	31.3	10.05	33.45	206	62	P	V
	*	5320	107.27	-	-	99.37	31.3	10.05	33.45	206	62	A	V
		5361.6	56.28	-17.72	74	48.27	31.35	10.1	33.44	206	62	P	V
		5364.48	48.05	-5.95	54	40.02	31.36	10.11	33.44	206	62	A	V
													V
													V
Remark	1. No other spurious found. 2. All results are PASS against Peak and Average limit line.												



Band 2 5250~5350MHz
WIFI 802.11a (Harmonic @ 3m)

WIFI Ant. 1+2	Note	Frequency (MHz)	Level (dBμV/m)	Over Limit (dB)	Limit Line (dBμV/m)	Read Level (dBμV)	Antenna Factor (dB/m)	Path Loss (dB)	Preamp Factor (dB)	Ant Pos (cm)	Table Pos (deg)	Peak Avg. (P/A)	Pol. (H/V)
802.11a CH 52 5260MHz		10520	47.07	-21.13	68.2	52.91	39.74	15.54	61.12	100	0	P	H
		15780	44.59	-29.41	74	48.72	37.64	19.49	61.26	100	0	P	H
													H
													H
		10520	45.9	-22.3	68.2	51.74	39.74	15.54	61.12	100	0	P	V
		15780	44.28	-29.72	74	48.41	37.64	19.49	61.26	100	0	P	V
													V
													V
802.11a CH 60 5300MHz		10600	46.62	-27.38	74	52.37	39.9	15.57	61.22	100	0	P	H
		15900	43.92	-30.08	74	48.17	37.3	19.57	61.12	100	0	P	H
													H
													H
		10600	46.1	-27.9	74	51.85	39.9	15.57	61.22	100	0	P	V
		15900	44.02	-29.98	74	48.27	37.3	19.57	61.12	100	0	P	V
													V
													V
802.11a CH 64 5320MHz		10640	45.71	-28.29	74	51.54	39.86	15.58	61.27	100	0	P	H
		15960	43.51	-30.49	74	47.6	37.36	19.6	61.05	100	0	P	H
													H
													H
		10640	45.35	-28.65	74	51.18	39.86	15.58	61.27	100	0	P	V
		15960	44.83	-29.17	74	48.92	37.36	19.6	61.05	100	0	P	V
													V
													V
Remark	1. No other spurious found. 2. All results are PASS against Peak and Average limit line.												



Band 2 5250~5350MHz
WIFI 802.11ac VHT20 (Band Edge @ 3m)

WIFI Ant. 1+2	Note	Frequency (MHz)	Level (dBμV/m)	Over Limit (dB)	Limit Line (dBμV/m)	Read Level (dBμV)	Antenna Factor (dB/m)	Path Loss (dB)	Preamp Factor (dB)	Ant Pos (cm)	Table Pos (deg)	Peak Avg. (P/A)	Pol. (H/V)
802.11ac VHT20 CH 52 5260MHz		5063.24	50.61	-23.39	74	42.53	31.85	9.7	33.47	185	251	P	H
		5148.24	42.55	-11.45	54	34.3	31.9	9.82	33.47	185	251	A	H
	*	5260	113.5	-	-	105.6	31.38	9.97	33.45	185	251	P	H
	*	5260	105.62	-	-	97.72	31.38	9.97	33.45	185	251	A	H
		5378.64	52.09	-21.91	74	44	31.41	10.12	33.44	185	251	P	H
		5350.8	44.28	-9.72	54	36.33	31.3	10.09	33.44	185	251	A	H
		5027.54	50.8	-23.2	74	43.01	31.62	9.65	33.48	209	62	P	V
		5138.04	42.53	-11.47	54	34.27	31.92	9.81	33.47	209	62	A	V
	*	5260	114.73	-	-	106.83	31.38	9.97	33.45	209	62	P	V
	*	5260	107.18	-	-	99.28	31.38	9.97	33.45	209	62	A	V
		5361.84	54.1	-19.9	74	46.09	31.35	10.1	33.44	209	62	P	V
		5355.84	45.71	-8.29	54	37.74	31.32	10.09	33.44	209	62	A	V
802.11ac VHT20 CH 60 5300MHz		5144.16	51.69	-22.31	74	43.43	31.91	9.82	33.47	186	252	P	H
		5106.08	42.22	-11.78	54	33.94	31.99	9.76	33.47	186	252	A	H
	*	5300	113.45	-	-	105.58	31.3	10.02	33.45	186	252	P	H
	*	5300	105.59	-	-	97.72	31.3	10.02	33.45	186	252	A	H
		5365.44	53.34	-20.66	74	45.31	31.36	10.11	33.44	186	252	P	H
		5350.32	45.67	-8.33	54	37.72	31.3	10.09	33.44	186	252	A	H
		5070.38	50.77	-23.23	74	42.65	31.88	9.71	33.47	208	62	P	V
		5136.34	42.34	-11.66	54	34.07	31.93	9.81	33.47	208	62	A	V
	*	5300	115.59	-	-	107.72	31.3	10.02	33.45	208	62	P	V
	*	5300	107.69	-	-	99.82	31.3	10.02	33.45	208	62	A	V
	5360.16	54.99	-19.01	74	46.99	31.34	10.1	33.44	208	62	P	V	
	5350.8	46.92	-7.08	54	38.97	31.3	10.09	33.44	208	62	A	V	



802.11ac VHT20 CH 64 5320MHz	*	5320	114.56	-	-	106.66	31.3	10.05	33.45	200	251	P	H
	*	5320	107.24	-	-	99.34	31.3	10.05	33.45	200	251	A	H
		5353.12	55.79	-18.21	74	47.83	31.31	10.09	33.44	200	251	P	H
		5350.24	49.48	-4.52	54	41.53	31.3	10.09	33.44	200	251	A	H
													H
													H
	*	5320	114.33	-	-	106.43	31.3	10.05	33.45	206	62	P	V
	*	5320	106.02	-	-	98.12	31.3	10.05	33.45	206	62	A	V
		5370.08	55.8	-18.2	74	47.75	31.38	10.11	33.44	206	62	P	V
		5350.4	48.45	-5.55	54	40.5	31.3	10.09	33.44	206	62	A	V
													V
													V
Remark	1. No other spurious found. 2. All results are PASS against Peak and Average limit line.												



Band 2 5250~5350MHz
WIFI 802.11ac VHT20 (Harmonic @ 3m)

WIFI Ant. 1+2	Note	Frequency (MHz)	Level (dBμV/m)	Over Limit (dB)	Limit Line (dBμV/m)	Read Level (dBμV)	Antenna Factor (dB/m)	Path Loss (dB)	Preamp Factor (dB)	Ant Pos (cm)	Table Pos (deg)	Peak Avg. (P/A)	Pol. (H/V)	
802.11ac VHT20 CH 52 5260MHz		10520	46.12	-22.08	68.2	51.96	39.74	15.54	61.12	100	0	P	H	
		15780	44.32	-29.68	74	48.45	37.64	19.49	61.26	100	0	P	H	
													H	
													H	
			10520	46.51	-21.69	68.2	52.35	39.74	15.54	61.12	100	0	P	V
			15780	43.49	-30.51	74	47.62	37.64	19.49	61.26	100	0	P	V
														V
802.11ac VHT20 CH 60 5300MHz		10600	47.08	-26.92	74	52.83	39.9	15.57	61.22	100	0	P	H	
		15900	43.6	-30.4	74	47.85	37.3	19.57	61.12	100	0	P	H	
													H	
													H	
			10600	44.95	-29.05	74	50.7	39.9	15.57	61.22	100	0	P	V
			15900	44.13	-29.87	74	48.38	37.3	19.57	61.12	100	0	P	V
														V
802.11ac VHT20 CH 64 5320MHz		10640	45.28	-28.72	74	51.11	39.86	15.58	61.27	100	0	P	H	
		15960	43.31	-30.69	74	47.4	37.36	19.6	61.05	100	0	P	H	
													H	
													H	
			10640	44.37	-29.63	74	50.2	39.86	15.58	61.27	100	0	P	V
			15960	43.02	-30.98	74	47.11	37.36	19.6	61.05	100	0	P	V
														V
Remark	1. No other spurious found.													
	2. All results are PASS against Peak and Average limit line.													



Band 2 5250~5350MHz
WIFI 802.11ac VHT40 (Band Edge @ 3m)

WIFI Ant. 1+2	Note	Frequency (MHz)	Level (dBμV/m)	Over Limit (dB)	Limit Line (dBμV/m)	Read Level (dBμV)	Antenna Factor (dB/m)	Path Loss (dB)	Preamp Factor (dB)	Ant Pos (cm)	Table Pos (deg)	Peak Avg. (P/A)	Pol. (H/V)
802.11ac VHT40 CH 54 5270MHz		5024.48	50.32	-23.68	74	42.55	31.6	9.65	33.48	194	252	P	H
		5047.26	43.14	-10.86	54	35.16	31.78	9.68	33.48	194	252	A	H
	*	5270	109.28	-	-	101.38	31.36	9.99	33.45	194	252	P	H
	*	5270	101.86	-	-	93.96	31.36	9.99	33.45	194	252	A	H
		5367.36	51.72	-22.28	74	43.68	31.37	10.11	33.44	194	252	P	H
		5353.44	45.05	-8.95	54	37.09	31.31	10.09	33.44	194	252	A	H
		5116.28	50.8	-23.2	74	42.52	31.97	9.78	33.47	199	64	P	V
		5089.42	43.15	-10.85	54	34.92	31.96	9.74	33.47	199	64	A	V
	*	5270	108.65	-	-	100.75	31.36	9.99	33.45	199	64	P	V
	*	5270	100.39	-	-	92.49	31.36	9.99	33.45	199	64	A	V
		5355.12	53.97	-20.03	74	46	31.32	10.09	33.44	199	64	P	V
		5350.8	47.59	-6.41	54	39.64	31.3	10.09	33.44	199	64	A	V
802.11ac VHT40 CH 62 5310MHz		5148.24	50.15	-23.85	74	41.9	31.9	9.82	33.47	200	254	P	H
		5107.78	42.99	-11.01	54	34.71	31.98	9.77	33.47	200	254	A	H
	*	5310	108.78	-	-	100.89	31.3	10.04	33.45	200	254	P	H
	*	5310	101.97	-	-	94.08	31.3	10.04	33.45	200	254	A	H
		5351.52	54.93	-19.07	74	46.97	31.31	10.09	33.44	200	254	P	H
		5350.32	49.39	-4.61	54	41.44	31.3	10.09	33.44	200	254	A	H
		5110.84	51.5	-22.5	74	43.22	31.98	9.77	33.47	177	83	P	V
		5142.46	43.03	-10.97	54	34.76	31.92	9.82	33.47	177	83	A	V
	*	5308	108.2	-	-	100.32	31.3	10.03	33.45	177	83	P	V
	*	5308	101.29	-	-	93.41	31.3	10.03	33.45	177	83	A	V
	5351.04	56.24	-17.76	74	48.29	31.3	10.09	33.44	177	83	P	V	
	5350.08	47.78	-6.22	54	39.83	31.3	10.09	33.44	177	83	A	V	
Remark	1. No other spurious found. 2. All results are PASS against Peak and Average limit line.												



**Band 2 5250~5350MHz
WIFI 802.11ac VHT40 (Harmonic @ 3m)**

WIFI Ant. 1+2	Note	Frequency (MHz)	Level (dBμV/m)	Over Limit (dB)	Limit Line (dBμV/m)	Read Level (dBμV)	Antenna Factor (dB/m)	Path Loss (dB)	Preamp Factor (dB)	Ant Pos (cm)	Table Pos (deg)	Peak Avg. (P/A)	Pol. (H/V)	
802.11ac VHT40 CH 54 5270MHz		10540	46.64	-21.56	68.2	52.46	39.78	15.55	61.15	100	0	P	H	
		15810	45.65	-28.35	74	49.8	37.57	19.51	61.23	100	0	P	H	
													H	
													H	
			10540	45.58	-22.62	68.2	51.4	39.78	15.55	61.15	100	0	P	V
			15810	45.64	-28.36	74	49.79	37.57	19.51	61.23	100	0	P	V
														V
802.11ac VHT40 CH 62 5310MHz		10620	44.48	-29.52	74	50.27	39.88	15.57	61.24	100	0	P	H	
		15930	44.9	-29.1	74	49.06	37.33	19.59	61.08	100	0	P	H	
													H	
													H	
			10620	45.27	-28.73	74	51.06	39.88	15.57	61.24	100	0	P	V
			15930	44	-30	74	48.16	37.33	19.59	61.08	100	0	P	V
														V
Remark	1. No other spurious found.													
	2. All results are PASS against Peak and Average limit line.													



Band 2 5250~5350MHz
WIFI 802.11ac VHT80 (Band Edge @ 3m)

WIFI Ant. 1+2	Note	Frequency (MHz)	Level (dBμV/m)	Over Limit (dB)	Limit Line (dBμV/m)	Read Level (dBμV)	Antenna Factor (dB/m)	Path Loss (dB)	Preamp Factor (dB)	Ant Pos (cm)	Table Pos (deg)	Peak Avg. (P/A)	Pol. (H/V)
802.11ac VHT80 CH 58 5290MHz		5021.08	50.88	-23.12	74	43.15	31.57	9.64	33.48	187	251	P	H
		5107.78	42.94	-11.06	54	34.66	31.98	9.77	33.47	187	251	A	H
	*	5290	101.56	-	-	93.68	31.32	10.01	33.45	187	251	P	H
	*	5290	94.97	-	-	87.09	31.32	10.01	33.45	187	251	A	H
		5353.44	55.28	-18.72	74	47.32	31.31	10.09	33.44	187	251	P	H
		5350.8	49.65	-4.35	54	41.7	31.3	10.09	33.44	187	251	A	H
		5140.08	51.27	-22.73	74	43.01	31.92	9.81	33.47	206	74	P	V
		5146.88	43.1	-10.9	54	34.84	31.91	9.82	33.47	206	74	A	V
	*	5290	102.77	-	-	94.89	31.32	10.01	33.45	206	74	P	V
	*	5290	95.75	-	-	87.87	31.32	10.01	33.45	206	74	A	V
		5352.24	56.72	-17.28	74	48.76	31.31	10.09	33.44	206	74	P	V
		5356.8	49.11	-4.89	54	41.12	31.33	10.1	33.44	206	74	A	V
Remark	1. No other spurious found. 2. All results are PASS against Peak and Average limit line.												



Band 2 5250~5350MHz
WIFI 802.11ac VHT80 (Harmonic @ 3m)

WIFI Ant. 1+2	Note	Frequency (MHz)	Level (dBμV/m)	Over Limit (dB)	Limit Line (dBμV/m)	Read Level (dBμV)	Antenna Factor (dB/m)	Path Loss (dB)	Preamp Factor (dB)	Ant Pos (cm)	Table Pos (deg)	Peak Avg. (P/A)	Pol. (H/V)	
802.11ac VHT80 CH 58 5290MHz		10580	45.33	-22.87	68.2	51.11	39.86	15.56	61.2	100	0	P	H	
		15870	44.55	-29.45	74	48.77	37.39	19.55	61.16	100	0	P	H	
													H	
													H	
			10580	45.18	-23.02	68.2	50.96	39.86	15.56	61.2	100	0	P	V
			15870	44.23	-29.77	74	48.45	37.39	19.55	61.16	100	0	P	V
														V
													V	
Remark	1. No other spurious found. 2. All results are PASS against Peak and Average limit line.													



Band 3 - 5470~5725MHz
WIFI 802.11a (Band Edge @ 3m)

WIFI	Note	Frequency	Level	Over	Limit	Read	Antenna	Path	Preamp	Ant	Table	Peak	Pol.	
Ant.				Limit	Line	Level	Factor	Loss	Factor	Pos	Pos	Avg.		
1+2		(MHz)	(dBμV/m)	(dB)	(dBμV/m)	(dBμV)	(dB/m)	(dB)	(dB)	(cm)	(deg)	(P/A)	(H/V)	
802.11a CH 100 5500MHz		5454.8	53.36	-20.64	74	44.84	31.72	10.23	33.43	188	253	P	H	
		5461.2	53.2	-15	68.2	44.65	31.74	10.24	33.43	188	253	P	H	
		5459.76	45.32	-8.68	54	36.78	31.74	10.23	33.43	188	253	A	H	
	*	5500	112.75	-	-	103.99	31.9	10.29	33.43	188	253	P	H	
	*	5500	105.34	-	-	96.58	31.9	10.29	33.43	188	253	A	H	
														H
			5459.76	54.41	-19.59	74	45.87	31.74	10.23	33.43	202	63	P	V
			5466.32	55.1	-13.1	68.2	46.52	31.77	10.24	33.43	202	63	P	V
			5458	47.52	-6.48	54	38.99	31.73	10.23	33.43	202	63	A	V
	*		5500	114.69	-	-	105.93	31.9	10.29	33.43	202	63	P	V
	*		5500	107.39	-	-	98.63	31.9	10.29	33.43	202	63	A	V
														V
802.11a CH 116 5580MHz		5416.96	50.59	-23.41	74	42.29	31.57	10.17	33.44	195	224	P	H	
		5462.56	49.22	-18.98	68.2	40.66	31.75	10.24	33.43	195	224	P	H	
		5452.96	42.62	-11.38	54	34.12	31.71	10.22	33.43	195	224	A	H	
	*	5580	111.57	-	-	102.81	31.8	10.4	33.44	195	224	P	H	
	*	5580	104.43	-	-	95.67	31.8	10.4	33.44	195	224	A	H	
			5725.625	51.27	-16.93	68.2	42.18	32.05	10.5	33.46	195	224	P	H
			5455.36	51.85	-22.15	74	43.33	31.72	10.23	33.43	209	62	P	V
			5462.8	51.04	-17.16	68.2	42.48	31.75	10.24	33.43	209	62	P	V
			5452.72	44.36	-9.64	54	35.86	31.71	10.22	33.43	209	62	A	V
	*		5580	115.5	-	-	106.74	31.8	10.4	33.44	209	62	P	V
	*		5580	107.93	-	-	99.17	31.8	10.4	33.44	209	62	A	V
			5733.5	52.45	-15.75	68.2	43.34	32.07	10.5	33.46	209	62	P	V



802.11a CH 140 5700MHz	*	5700	112.14	-	-	103.11	32	10.49	33.46	212	227	P	H
	*	5700	104.88	-	-	95.85	32	10.49	33.46	212	227	A	H
		5733.08	54.09	-14.11	68.2	44.98	32.07	10.5	33.46	212	227	P	H
													H
													H
													H
	*	5700	115.75	-	-	106.72	32	10.49	33.46	209	60	P	V
	*	5700	108.2	-	-	99.17	32	10.49	33.46	209	60	A	V
		5743.64	57.04	-11.16	68.2	47.9	32.09	10.51	33.46	209	60	P	V
													V
													V
													V
Remark	1. No other spurious found. 2. All results are PASS against Peak and Average limit line.												



**Band 3 - 5470~5725MHz
WIFI 802.11a (Harmonic @ 3m)**

WIFI Ant. 1+2	Note	Frequency (MHz)	Level (dBµV/m)	Over Limit (dB)	Limit Line (dBµV/m)	Read Level (dBµV)	Antenna Factor (dB/m)	Path Loss (dB)	Preamp Factor (dB)	Ant Pos (cm)	Table Pos (deg)	Peak Avg. (P/A)	Pol. (H/V)	
802.11a CH 100 5500MHz		11000	47.13	-26.87	74	52.02	40.2	16.61	61.7	100	0	P	H	
		16500	47.28	-20.92	68.2	46.38	39.4	21.2	59.7	100	0	P	H	
													H	
													H	
			11000	46.99	-27.01	74	51.88	40.2	16.61	61.7	100	0	P	V
			16500	47.41	-20.79	68.2	46.51	39.4	21.2	59.7	100	0	P	V
														V
														V
802.11a CH 116 5580MHz		11160	46	-28	74	51.5	39.62	16.74	61.86	100	0	P	H	
		16740	49.61	-18.59	68.2	47.38	40.4	21.48	59.65	100	0	P	H	
													H	
													H	
			11160	46.64	-27.36	74	52.14	39.62	16.74	61.86	100	0	P	V
			16740	49.04	-19.16	68.2	46.81	40.4	21.48	59.65	100	0	P	V
														V
														V
802.11a CH 140 5700MHz		11400	46.44	-27.56	74	52	39.6	16.94	62.1	100	0	P	H	
		17100	49.13	-19.07	68.2	46.06	40.5	21.95	59.38	100	0	P	H	
													H	
													H	
			11400	45.99	-28.01	74	51.55	39.6	16.94	62.1	100	0	P	V
			17100	49.27	-18.93	68.2	46.2	40.5	21.95	59.38	100	0	P	V
														V
														V
Remark	1. No other spurious found. 2. All results are PASS against Peak and Average limit line.													



Band 3 - 5470~5725MHz
WIFI 802.11ac VHT20 (Band Edge @ 3m)

WIFI Ant. 1+2	Note	Frequency (MHz)	Level (dBμV/m)	Over Limit (dB)	Limit Line (dBμV/m)	Read Level (dBμV)	Antenna Factor (dB/m)	Path Loss (dB)	Preamp Factor (dB)	Ant Pos (cm)	Table Pos (deg)	Peak Avg. (P/A)	Pol. (H/V)	
802.11ac VHT20 CH 100 5500MHz		5458.48	53.14	-20.86	74	44.61	31.73	10.23	33.43	196	248	P	H	
		5468.72	53.74	-14.46	68.2	45.15	31.77	10.25	33.43	196	248	P	H	
		5459.12	45.57	-8.43	54	37.03	31.74	10.23	33.43	196	248	A	H	
	*	5500	113	-	-	104.24	31.9	10.29	33.43	196	248	P	H	
	*	5500	105.33	-	-	96.57	31.9	10.29	33.43	196	248	A	H	
														H
			5458.32	55.75	-18.25	74	47.22	31.73	10.23	33.43	204	63	P	V
			5469.52	55.18	-13.02	68.2	46.58	31.78	10.25	33.43	204	63	P	V
			5459.6	47.99	-6.01	54	39.45	31.74	10.23	33.43	204	63	A	V
	*		5500	115.26	-	-	106.5	31.9	10.29	33.43	204	63	P	V
	*		5500	107.68	-	-	98.92	31.9	10.29	33.43	204	63	A	V
													V	
802.11ac VHT20 CH 116 5580MHz		5363.2	50.62	-23.38	74	42.61	31.35	10.1	33.44	210	226	P	H	
		5467.6	49.28	-18.92	68.2	40.7	31.77	10.24	33.43	210	226	P	H	
		5458.72	42.73	-11.27	54	34.2	31.73	10.23	33.43	210	226	A	H	
	*	5580	112.21	-	-	103.45	31.8	10.4	33.44	210	226	P	H	
	*	5580	104.6	-	-	95.84	31.8	10.4	33.44	210	226	A	H	
			5751.77	52.29	-15.91	68.2	43.15	32.1	10.51	33.47	210	226	P	H
			5446.48	51.17	-22.83	74	42.7	31.69	10.22	33.44	214	60	P	V
			5468.08	52.1	-16.1	68.2	43.51	31.77	10.25	33.43	214	60	P	V
			5452.96	44.29	-9.71	54	35.79	31.71	10.22	33.43	214	60	A	V
	*		5580	115.49	-	-	106.73	31.8	10.4	33.44	214	60	P	V
	*		5580	107.93	-	-	99.17	31.8	10.4	33.44	214	60	A	V
		5738.54	52.32	-15.88	68.2	43.19	32.08	10.51	33.46	214	60	P	V	



802.11ac VHT20 CH 140 5700MHz	*	5700	111.62	-	-	102.59	32	10.49	33.46	219	182	P	H
	*	5700	104.43	-	-	95.4	32	10.49	33.46	219	182	A	H
		5745.32	54.12	-14.08	68.2	44.98	32.09	10.51	33.46	219	182	P	H
													H
													H
													H
	*	5700	115.89	-	-	106.86	32	10.49	33.46	205	63	P	V
	*	5700	108.41	-	-	99.38	32	10.49	33.46	205	63	A	V
		5730.28	57.11	-11.09	68.2	48.01	32.06	10.5	33.46	205	63	P	V
													V
													V
													V
Remark	1. No other spurious found. 2. All results are PASS against Peak and Average limit line.												



Band 3 - 5470~5725MHz
WIFI 802.11ac VHT20 (Harmonic @ 3m)

WIFI Ant. 1+2	Note	Frequency (MHz)	Level (dBµV/m)	Over Limit (dB)	Limit Line (dBµV/m)	Read Level (dBµV)	Antenna Factor (dB/m)	Path Loss (dB)	Preamp Factor (dB)	Ant Pos (cm)	Table Pos (deg)	Peak Avg. (P/A)	Pol. (H/V)	
802.11ac VHT20 CH 100 5500MHz		11000	46.84	-27.16	74	51.73	40.2	16.61	61.7	100	0	P	H	
		16500	47.83	-20.37	68.2	46.93	39.4	21.2	59.7	100	0	P	H	
													H	
													H	
			11000	47.11	-26.89	74	52	40.2	16.61	61.7	100	0	P	V
			16500	47.75	-20.45	68.2	46.85	39.4	21.2	59.7	100	0	P	V
														V
802.11ac VHT20 CH 116 5580MHz		11160	45.82	-28.18	74	51.32	39.62	16.74	61.86	100	0	P	H	
		16740	49.95	-18.25	68.2	47.72	40.4	21.48	59.65	100	0	P	H	
													H	
													H	
			11160	46.25	-27.75	74	51.75	39.62	16.74	61.86	100	0	P	V
			16740	49.37	-18.83	68.2	47.14	40.4	21.48	59.65	100	0	P	V
														V
802.11ac VHT20 CH 140 5700MHz		11400	46.71	-27.29	74	52.27	39.6	16.94	62.1	100	0	P	H	
		17100	50.25	-17.95	68.2	47.18	40.5	21.95	59.38	100	0	P	H	
													H	
													H	
			11400	45.73	-28.27	74	51.29	39.6	16.94	62.1	100	0	P	V
			17100	49.78	-18.42	68.2	46.71	40.5	21.95	59.38	100	0	P	V
														V
Remark	1. No other spurious found.													
	2. All results are PASS against Peak and Average limit line.													



Band 3 - 5470~5725MHz
WIFI 802.11ac VHT40 (Band Edge @ 3m)

WIFI Ant. 1+2	Note	Frequency (MHz)	Level (dBμV/m)	Over Limit (dB)	Limit Line (dBμV/m)	Read Level (dBμV)	Antenna Factor (dB/m)	Path Loss (dB)	Preamp Factor (dB)	Ant Pos (cm)	Table Pos (deg)	Peak Avg. (P/A)	Pol. (H/V)
802.11ac VHT40 CH 102 5510MHz		5459.2	57.34	-16.66	74	48.8	31.74	10.23	33.43	191	254	P	H
		5467.6	62.07	-6.13	68.2	53.49	31.77	10.24	33.43	191	254	P	H
		5457.52	52.02	-1.98	54	43.49	31.73	10.23	33.43	191	254	A	H
	*	5510	110.71	-	-	101.96	31.88	10.3	33.43	191	254	P	H
	*	5510	103.44	-	-	94.69	31.88	10.3	33.43	191	254	A	H
		5738.54	52.19	-16.01	68.2	43.06	32.08	10.51	33.46	191	254	P	H
		5452.72	56.92	-17.08	74	48.42	31.71	10.22	33.43	204	61	P	V
		5469.28	59.37	-8.83	68.2	50.77	31.78	10.25	33.43	204	61	P	V
		5452.48	50.38	-3.62	54	41.88	31.71	10.22	33.43	204	61	A	V
	*	5510	113.05	-	-	104.3	31.88	10.3	33.43	204	61	P	V
	*	5510	106.27	-	-	97.52	31.88	10.3	33.43	204	61	A	V
		5736.965	56.91	-11.29	68.2	47.79	32.07	10.51	33.46	204	61	P	V
802.11ac VHT40 CH 110 5550MHz		5434	50.58	-23.42	74	42.18	31.64	10.2	33.44	185	194	P	H
		5468.32	50.79	-17.41	68.2	42.2	31.77	10.25	33.43	185	194	P	H
		5457.76	43.77	-10.23	54	35.24	31.73	10.23	33.43	185	194	A	H
	*	5550	111.07	-	-	102.35	31.8	10.36	33.44	185	194	P	H
	*	5550	103.46	-	-	94.74	31.8	10.36	33.44	185	194	A	H
		5737.28	51.26	-16.94	68.2	42.14	32.07	10.51	33.46	185	194	P	H
		5452.72	53.07	-20.93	74	44.57	31.71	10.22	33.43	215	61	P	V
		5469.28	54.32	-13.88	68.2	45.72	31.78	10.25	33.43	215	61	P	V
		5452.72	46.65	-7.35	54	38.15	31.71	10.22	33.43	215	61	A	V
	*	5550	113.82	-	-	105.1	31.8	10.36	33.44	215	61	P	V
	*	5550	106.44	-	-	97.72	31.8	10.36	33.44	215	61	A	V
		5725.31	52.84	-15.36	68.2	43.75	32.05	10.5	33.46	215	61	P	V



802.11ac VHT40 CH 134 5670MHz		5445.9	52.45	-21.55	74	44	31.68	10.21	33.44	208	225	P	H
		5467.25	50.09	-18.11	68.2	41.51	31.77	10.24	33.43	208	225	P	H
		5447.65	45.1	-8.9	54	36.63	31.69	10.22	33.44	208	225	A	H
	*	5670	110.65	-	-	101.81	31.82	10.47	33.45	208	225	P	H
	*	5670	103.05	-	-	94.21	31.82	10.47	33.45	208	225	A	H
		5728.6	54.96	-13.24	68.2	45.86	32.06	10.5	33.46	208	225	P	H
		5447.65	53.11	-20.89	74	44.64	31.69	10.22	33.44	205	62	P	V
		5466.55	51.58	-16.62	68.2	43	31.77	10.24	33.43	205	62	P	V
		5447.65	47.64	-6.36	54	39.17	31.69	10.22	33.44	205	62	A	V
	*	5670	113.75	-	-	104.91	31.82	10.47	33.45	205	62	P	V
	*	5670	106.07	-	-	97.23	31.82	10.47	33.45	205	62	A	V
		5730.525	58.62	-9.58	68.2	49.52	32.06	10.5	33.46	205	62	P	V
Remark	1. No other spurious found. 2. All results are PASS against Peak and Average limit line.												



Band 3 - 5470~5725MHz
WIFI 802.11ac VHT40 (Harmonic @ 3m)

WIFI Ant. 1+2	Note	Frequency (MHz)	Level (dBµV/m)	Over Limit (dB)	Limit Line (dBµV/m)	Read Level (dBµV)	Antenna Factor (dB/m)	Path Loss (dB)	Preamp Factor (dB)	Ant Pos (cm)	Table Pos (deg)	Peak Avg. (P/A)	Pol. (H/V)	
802.11ac VHT40 CH 102 5510MHz		11020	46.06	-27.94	74	51.03	40.12	16.63	61.72	100	0	P	H	
		16530	47.56	-20.64	68.2	46.62	39.4	21.23	59.69	100	0	P	H	
													H	
													H	
			11020	46.7	-27.3	74	51.67	40.12	16.63	61.72	100	0	P	V
			16530	48.08	-20.12	68.2	47.14	39.4	21.23	59.69	100	0	P	V
														V
802.11ac VHT40 CH 110 5550MHz		11100	46.08	-27.92	74	51.39	39.8	16.69	61.8	100	0	P	H	
		16650	48.09	-20.11	68.2	46.58	39.8	21.38	59.67	100	0	P	H	
													H	
													H	
			11100	46.16	-27.84	74	51.47	39.8	16.69	61.8	100	0	P	V
			16650	48.36	-19.84	68.2	46.85	39.8	21.38	59.67	100	0	P	V
														V
802.11ac VHT40 CH 134 5670MHz		11340	46.16	-27.84	74	51.77	39.54	16.89	62.04	100	0	P	H	
		17010	48.74	-19.46	68.2	46.01	40.5	21.81	59.58	100	0	P	H	
													H	
													H	
			11340	46.27	-27.73	74	51.88	39.54	16.89	62.04	100	0	P	V
			17010	49.13	-19.07	68.2	46.4	40.5	21.81	59.58	100	0	P	V
														V
Remark	1. No other spurious found.													
	2. All results are PASS against Peak and Average limit line.													



Band 3 5470~5725MHz
WIFI 802.11ac VHT80 (Band Edge @ 3m)

WIFI Ant. 1+2	Note	Frequency (MHz)	Level (dBμV/m)	Over Limit (dB)	Limit Line (dBμV/m)	Read Level (dBμV)	Antenna Factor (dB/m)	Path Loss (dB)	Preamp Factor (dB)	Ant Pos (cm)	Table Pos (deg)	Peak Avg. (P/A)	Pol. (H/V)
802.11ac VHT80 CH 106 5530MHz		5456.8	56.59	-17.41	74	48.06	31.73	10.23	33.43	189	252	P	H
		5459.92	56.27	-17.73	74	47.73	31.74	10.23	33.43	189	252	P	H
		5455.6	50.3	-3.7	54	41.78	31.72	10.23	33.43	189	252	A	H
	*	5530	102.36	-	-	93.62	31.84	10.33	33.43	189	252	P	H
	*	5530	95.12	-	-	86.38	31.84	10.33	33.43	189	252	A	H
		5750.51	50.79	-17.41	68.2	41.65	32.1	10.51	33.47	189	252	P	H
		5447.68	55.32	-18.68	74	46.85	31.69	10.22	33.44	203	59	P	V
		5462.08	59.07	-9.13	68.2	50.51	31.75	10.24	33.43	203	59	P	V
		5458.48	48.32	-5.68	54	39.79	31.73	10.23	33.43	203	59	A	V
	*	5530	104.76	-	-	96.02	31.84	10.33	33.43	203	59	P	V
	*	5530	98.02	-	-	89.28	31.84	10.33	33.43	203	59	A	V
		5739.8	52.78	-15.42	68.2	43.65	32.08	10.51	33.46	203	59	P	V
802.11ac VHT80 CH 122 5610MHz		5453.92	53.02	-20.98	74	44.5	31.72	10.23	33.43	191	251	P	H
		5464	55.23	-12.97	68.2	46.66	31.76	10.24	33.43	191	251	P	H
		5456.56	44.99	-9.01	54	36.46	31.73	10.23	33.43	191	251	A	H
	*	5610	108.39	-	-	99.62	31.78	10.44	33.45	191	251	P	H
	*	5610	101.25	-	-	92.48	31.78	10.44	33.45	191	251	A	H
		5727.515	54.01	-14.19	68.2	44.91	32.06	10.5	33.46	191	251	P	H
		5452.24	52.56	-21.44	74	44.06	31.71	10.22	33.43	209	62	P	V
		5467.6	52.04	-16.16	68.2	43.46	31.77	10.24	33.43	209	62	P	V
		5452.72	46.31	-7.69	54	37.81	31.71	10.22	33.43	209	62	A	V
	*	5610	112.14	-	-	103.37	31.78	10.44	33.45	209	62	P	V
	*	5610	104.54	-	-	95.77	31.78	10.44	33.45	209	62	A	V
	5740.115	56.04	-12.16	68.2	46.91	32.08	10.51	33.46	209	62	P	V	
Remark	1. No other spurious found. 2. All results are PASS against Peak and Average limit line.												



Band 3 5470~5725MHz
WIFI 802.11ac VHT80 (Harmonic @ 3m)

WIFI Ant. 1+2	Note	Frequency (MHz)	Level (dBμV/m)	Over Limit (dB)	Limit Line (dBμV/m)	Read Level (dBμV)	Antenna Factor (dB/m)	Path Loss (dB)	Preamp Factor (dB)	Ant Pos (cm)	Table Pos (deg)	Peak Avg. (P/A)	Pol. (H/V)	
802.11ac VHT80 CH 106 5530MHz		11060	46.67	-27.33	74	51.81	39.96	16.66	61.76	100	0	P	H	
		16590	47.73	-20.47	68.2	46.71	39.4	21.3	59.68	100	0	P	H	
													H	
													H	
			11060	45.5	-28.5	74	50.64	39.96	16.66	61.76	100	0	P	V
			16590	47.92	-20.28	68.2	46.9	39.4	21.3	59.68	100	0	P	V
														V
802.11ac VHT80 CH 122 5610MHz		11220	45.36	-28.64	74	50.99	39.5	16.79	61.92	100	0	P	H	
		16830	48.92	-19.28	68.2	46.44	40.52	21.59	59.63	100	0	P	H	
													H	
													H	
			11220	45.7	-28.3	74	51.33	39.5	16.79	61.92	100	0	P	V
			16830	49.1	-19.1	68.2	46.62	40.52	21.59	59.63	100	0	P	V
														V
Remark	1. No other spurious found.													
	2. All results are PASS against Peak and Average limit line.													



Band 3 - Straddle Channel
WIFI 802.11a (Band Edge @ 3m)

WIFI	Note	Frequency	Level	Over	Limit	Read	Antenna	Path	Preamp	Ant	Table	Peak	Pol.
Ant.				Limit	Line	Level	Factor	Loss	Factor	Pos	Pos	Avg.	
1+2		(MHz)	(dBµV/m)	(dB)	(dBµV/m)	(dBµV)	(dB/m)	(dB)	(dB)	(cm)	(deg)	(P/A)	(H/V)
802.11a CH 144 5720MHz	*	5720	112.32	-	-	103.24	32.04	10.5	33.46	200	226	P	H
	*	5720	105.06	-	-	95.98	32.04	10.5	33.46	200	226	A	H
													H
													H
													H
	*	5720	115.7	-	-	106.62	32.04	10.5	33.46	209	61	P	V
	*	5720	108.18	-	-	99.1	32.04	10.5	33.46	209	61	A	V
													V
													V
													V
													V
	Remark	1. No other spurious found. 2. All results are PASS against Peak and Average limit line.											



**Band 3 - Straddle Channel
WIFI 802.11a (Harmonic @ 3m)**

WIFI Ant. 1+2	Note	Frequency (MHz)	Level (dBµV/m)	Over Limit (dB)	Limit Line (dBµV/m)	Read Level (dBµV)	Antenna Factor (dB/m)	Path Loss (dB)	Preamp Factor (dB)	Ant Pos (cm)	Table Pos (deg)	Peak Avg. (P/A)	Pol. (H/V)	
802.11a CH 144 5720MHz		11440	45.82	-28.18	74	51.32	39.68	16.96	62.14	100	0	P	H	
		17160	49.19	-19.01	68.2	45.84	40.56	22.04	59.25	100	0	P	H	
													H	
													H	
			11440	45.71	-28.29	74	51.21	39.68	16.96	62.14	100	0	P	V
			17160	48.97	-19.23	68.2	45.62	40.56	22.04	59.25	100	0	P	V
														V
														V
Remark	1. No other spurious found. 2. All results are PASS against Peak and Average limit line.													



**Band 3 - Straddle Channel
WIFI 802.11ac VHT20 (Band Edge @ 3m)**

WIFI Ant. 1+2	Note	Frequency (MHz)	Level (dBμV/m)	Over Limit (dB)	Limit Line (dBμV/m)	Read Level (dBμV)	Antenna Factor (dB/m)	Path Loss (dB)	Preamp Factor (dB)	Ant Pos (cm)	Table Pos (deg)	Peak Avg. (P/A)	Pol. (H/V)
802.11ac VHT20 CH 144 5720MHz	*	5720	112.35	-	-	103.27	32.04	10.5	33.46	200	228	P	H
	*	5720	105.22	-	-	96.14	32.04	10.5	33.46	200	228	A	H
													H
													H
													H
													H
	*	5720	115.42	-	-	106.34	32.04	10.5	33.46	198	62	P	V
	*	5720	107.17	-	-	98.09	32.04	10.5	33.46	198	62	A	V
													V
													V
												V	
												V	
Remark	1. No other spurious found. 2. All results are PASS against Peak and Average limit line.												



**Band 3 - Straddle Channel
WIFI 802.11ac VHT20 (Harmonic @ 3m)**

WIFI Ant. 1+2	Note	Frequency (MHz)	Level (dBµV/m)	Over Limit (dB)	Limit Line (dBµV/m)	Read Level (dBµV)	Antenna Factor (dB/m)	Path Loss (dB)	Preamp Factor (dB)	Ant Pos (cm)	Table Pos (deg)	Peak Avg. (P/A)	Pol. (H/V)	
802.11ac VHT20 CH 144 5720MHz		11440	46.82	-27.18	74	52.32	39.68	16.96	62.14	100	0	P	H	
		17160	50.11	-18.09	68.2	46.76	40.56	22.04	59.25	100	0	P	H	
													H	
													H	
			11440	47.06	-26.94	74	52.56	39.68	16.96	62.14	100	0	P	V
			17160	49.11	-19.09	68.2	45.76	40.56	22.04	59.25	100	0	P	V
														V
														V
Remark	1. No other spurious found. 2. All results are PASS against Peak and Average limit line.													



**Band 3 - Straddle Channel
WIFI 802.11ac VHT40 (Band Edge @ 3m)**

WIFI Ant. 1+2	Note	Frequency (MHz)	Level (dBµV/m)	Over Limit (dB)	Limit Line (dBµV/m)	Read Level (dBµV)	Antenna Factor (dB/m)	Path Loss (dB)	Preamp Factor (dB)	Ant Pos (cm)	Table Pos (deg)	Peak Avg. (P/A)	Pol. (H/V)
802.11ac VHT40 CH 142 5710MHz	*	5710	110.99	-	-	101.94	32.02	10.49	33.46	190	226	P	H
	*	5710	103.53	-	-	94.48	32.02	10.49	33.46	190	226	A	H
													H
													H
													H
													H
	*	5710	114.59	-	-	105.54	32.02	10.49	33.46	205	63	P	V
	*	5710	106.98	-	-	97.93	32.02	10.49	33.46	205	63	A	V
													V
													V
												V	
												V	
Remark	1. No other spurious found. 2. All results are PASS against Peak and Average limit line.												



**Band 3 - Straddle Channel
WIFI 802.11ac VHT40 (Harmonic @ 3m)**

WIFI Ant. 1+2	Note	Frequency (MHz)	Level (dBµV/m)	Over Limit (dB)	Limit Line (dBµV/m)	Read Level (dBµV)	Antenna Factor (dB/m)	Path Loss (dB)	Preamp Factor (dB)	Ant Pos (cm)	Table Pos (deg)	Peak Avg. (P/A)	Pol. (H/V)	
802.11ac VHT40 CH 142 5710MHz		11420	45.73	-28.27	74	51.27	39.64	16.94	62.12	100	0	P	H	
		17130	49.55	-18.65	68.2	46.33	40.53	22	59.31	100	0	P	H	
													H	
													H	
			11420	45.38	-28.62	74	50.92	39.64	16.94	62.12	100	0	P	V
			17130	48.89	-19.31	68.2	45.67	40.53	22	59.31	100	0	P	V
														V
														V
Remark	1. No other spurious found. 2. All results are PASS against Peak and Average limit line.													



**Band 3 - Straddle Channel
WIFI 802.11ac VHT80 (Band Edge @ 3m)**

WIFI Ant. 1+2	Note	Frequency (MHz)	Level (dBμV/m)	Over Limit (dB)	Limit Line (dBμV/m)	Read Level (dBμV)	Antenna Factor (dB/m)	Path Loss (dB)	Preamp Factor (dB)	Ant Pos (cm)	Table Pos (deg)	Peak Avg. (P/A)	Pol. (H/V)
802.11ac VHT80 CH 138 5690MHz	*	5690	103.18	-	-	94.22	31.94	10.48	33.46	186	226	P	H
	*	5690	95.52	-	-	86.56	31.94	10.48	33.46	186	226	A	H
													H
													H
													H
													H
	*	5690	106.68	-	-	97.72	31.94	10.48	33.46	205	61	P	V
	*	5690	99.01	-	-	90.05	31.94	10.48	33.46	205	61	A	V
													V
													V
												V	
												V	
Remark	1. No other spurious found. 2. All results are PASS against Peak and Average limit line.												



**Band 3 - Straddle Channel
WIFI 802.11ac VHT80 (Harmonic @ 3m)**

WIFI Ant. 1+2	Note	Frequency (MHz)	Level (dBμV/m)	Over Limit (dB)	Limit Line (dBμV/m)	Read Level (dBμV)	Antenna Factor (dB/m)	Path Loss (dB)	Preamp Factor (dB)	Ant Pos (cm)	Table Pos (deg)	Peak Avg. (P/A)	Pol. (H/V)	
802.11ac VHT80 CH 138 5690MHz		11380	45.5	-28.5	74	51.08	39.58	16.92	62.08	100	0	P	H	
		17070	49.17	-19.03	68.2	46.22	40.5	21.9	59.45	100	0	P	H	
													H	
													H	
			11380	45.77	-28.23	74	51.35	39.58	16.92	62.08	100	0	P	V
			17070	49.44	-18.76	68.2	46.49	40.5	21.9	59.45	100	0	P	V
														V
														V
Remark	1. No other spurious found. 2. All results are PASS against Peak and Average limit line.													



Emission below 1GHz

5GHz WIFI 802.11ac VHT40 (LF @ 3m)

WIFI	Note	Frequency	Level	Over	Limit	Read	Antenna	Path	Preamp	Ant	Table	Peak	Pol.	
Ant.				Limit	Line	Level	Factor	Loss	Factor	Pos	Pos	Avg.		
1+2		(MHz)	(dBµV/m)	(dB)	(dBµV/m)	(dBµV)	(dB/m)	(dB)	(dB)	(cm)	(deg)	(P/A)	(H/V)	
5GHz 802.11ac VHT40 LF		30.97	24.01	-15.99	40	29.69	23.74	0.78	30.2	-	-	P	H	
		103.72	29.08	-14.42	43.5	41.66	16.38	1.47	30.43	-	-	P	H	
		224	29.74	-16.26	46	42.44	15.54	2.04	30.28	-	-	P	H	
		729.37	35.91	-10.09	46	34.11	27.47	3.78	29.45	-	-	P	H	
		855.47	34.29	-11.71	46	30.19	29.19	4.12	29.21	-	-	P	H	
		957.32	36.21	-9.79	46	29.94	30.78	4.46	28.97	100	0	P	H	
													H	
													H	
													H	
													H	
													H	
													H	
													H	
													H	
													H	
			32.91	29.42	-10.58	40	35.95	22.89	0.81	30.23	-	-	P	V
			174.53	27.57	-15.93	43.5	40.65	15.36	1.91	30.35	-	-	P	V
			224.97	25.84	-20.16	46	38.44	15.64	2.04	30.28	-	-	P	V
		745.86	34.53	-11.47	46	32.21	27.91	3.83	29.42	-	-	P	V	
		866.14	34.36	-11.64	46	30.16	29.23	4.16	29.19	-	-	P	V	
		942.77	36.04	-9.96	46	30.37	30.28	4.41	29.02	100	0	P	V	
													V	
													V	
													V	
													V	
													V	
													V	
													V	
Remark	1. No other spurious found. 2. All results are PASS against limit line.													



Note symbol

*	Fundamental Frequency which can be ignored. However, the level of any unwanted emissions shall not exceed the level of the fundamental frequency.
!	Test result is over limit line.
P/A	Peak or Average
H/V	Horizontal or Vertical



A calculation example for radiated spurious emission is shown as below:

WIFI	Note	Frequency	Level	Over	Limit	Read	Antenna	Path	Preamp	Ant	Table	Peak	Pol.
Ant.				Limit	Line	Level	Factor	Loss	Factor	Pos	Pos	Avg.	
1+2		(MHz)	(dBμV/m)	(dB)	(dBμV/m)	(dBμV)	(dB/m)	(dB)	(dB)	(cm)	(deg)	(P/A)	(H/V)
802.11b		2390	55.45	-18.55	74	54.51	32.22	4.58	35.86	103	308	P	H
CH 01													
2412MHz		2390	43.54	-10.46	54	42.6	32.22	4.58	35.86	103	308	A	H

1. Path Loss(dB) = Cable loss(dB) + Filter loss(dB) + Attenuator loss(dB)
2. Level(dBμV/m) = Antenna Factor(dB/m) + Path Loss(dB) + Read Level(dBμV) - Preamp Factor(dB)
3. Over Limit(dB) = Level(dBμV/m) – Limit Line(dBμV/m)

For Peak Limit @ 2390MHz:

1. Level(dBμV/m)
= Antenna Factor(dB/m) + Path Loss(dB) + Read Level(dBμV) - Preamp Factor(dB)
= 32.22(dB/m) + 4.58(dB) + 54.51(dBμV) – 35.86 (dB)
= 55.45 (dBμV/m)
2. Over Limit(dB)
= Level(dBμV/m) – Limit Line(dBμV/m)
= 55.45(dBμV/m) – 74(dBμV/m)
= -18.55(dB)

For Average Limit @ 2390MHz:

1. Level(dBμV/m)
= Antenna Factor(dB/m) + Path Loss(dB) + Read Level(dBμV) - Preamp Factor(dB)
= 32.22(dB/m) + 4.58(dB) + 42.6(dBμV) – 35.86 (dB)
= 43.54 (dBμV/m)
2. Over Limit(dB) = Level(dBμV/m) – Limit Line(dBμV/m)
= 43.54(dBμV/m) – 54(dBμV/m)
= -10.46(dB)

Both peak and average measured complies with the limit line, so test result is “PASS”.



Appendix D. Radiated Spurious Emission Plots

Test Engineer :	Jack Cheng, Lance Chiang, Chuan Chu	Temperature :	21~24°C
		Relative Humidity :	56~68%

Note symbol

-L	Low channel location
-R	High channel location



Band 1 - 5150~5250MHz
WIFI 802.11a (Band Edge @ 3m)

WIFI	Band 1 5150~5250MHz Band Edge @ 3m	
ANT	802.11a CH36 5180MHz	
1+2	Horizontal	Fundamental
Peak	<p>Site : 03CH12-HY Condition : PEAK_BE_74 3m HORN_9120D_1328 HORIZONTAL RBW:1000.000kHz VBW:3000.000kHz SWT:Auto Detector : Peak Project : 952409 Mode : 1 Setting : 16.5</p>	<p>Site : 03CH12-HY Condition : PEAK(FUNEL) 3m HORN_9120D_1328 HORIZONTAL RBW:1000.000kHz VBW:3000.000kHz SWT:Auto Detector : Peak Project : 952409 Mode : 1 Setting : 16.5</p>
Avg.	<p>Site : 03CH12-HY Condition : AVG_BE_54 3m HORN_9120D_1328 HORIZONTAL RBW:1000.000kHz VBW:1.000kHz SWT:Auto Detector : Peak Project : 952409 Mode : 1 Setting : 16.5</p>	Left blank



WIFI	Band 1 5150~5250MHz Band Edge @ 3m	
ANT	802.11a CH36 5180MHz	
1+2	Vertical	Fundamental
Peak	<p>Site : 03CH12-11Y Condition : PEAK_BE_74 3m HORN_9120D_1328 VERTICAL : RBW:1000.000KHz VBW:3000.000KHz SWT:Auto Detector : Peak Project : 952409 Mode : 1 Setting : 16.5</p>	<p>Site : 03CH12-11Y Condition : PEAK(FUND) 3m HORN_9120D_1328 VERTICAL : RBW:1000.000KHz VBW:3000.000KHz SWT:Auto Detector : Peak Project : 952409 Mode : 1 Setting : 16.5</p>
Avg.	<p>Site : 03CH12-11Y Condition : AVG_BE_54 3m HORN_9120D_1328 VERTICAL : RBW:1000.000KHz VBW:1.000KHz SWT:Auto Detector : Peak Project : 952409 Mode : 1 Setting : 16.5</p>	Left blank

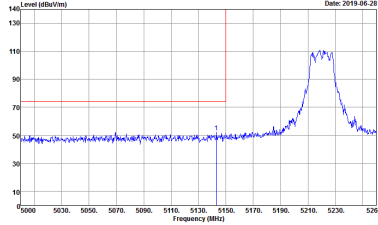
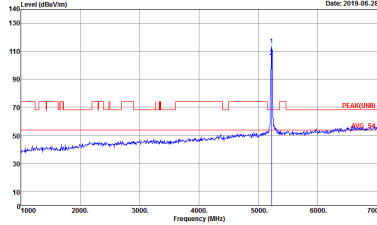
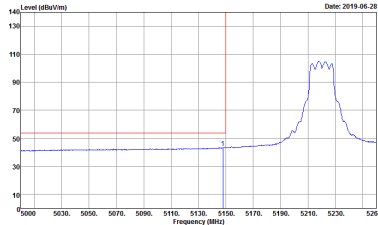

WIFI	Band 1 5150~5250MHz Band Edge @ 3m	
ANT	802.11a CH44 5220MHz - L	
1+2	Horizontal	Fundamental
<p>Peak</p>	 <p>Site : 03CH12-11Y Condition : PEAK_BE_74 3m HORN_9120D_1328 HORIZONTAL Detector : Peak Project : 952409 Mode : 2 Setting : 16.5</p>	 <p>Site : 03CH12-11Y Condition : PEAK(UNL1) 3m HORN_9120D_1328 HORIZONTAL Detector : Peak Project : 952409 Mode : 2 Setting : 16.5</p>
<p>Avg.</p>	 <p>Site : 03CH12-11Y Condition : AVG_BE_54 3m HORN_9120D_1328 HORIZONTAL Detector : Peak Project : 952409 Mode : 2 Setting : 16.5</p>	<p>Left blank</p>

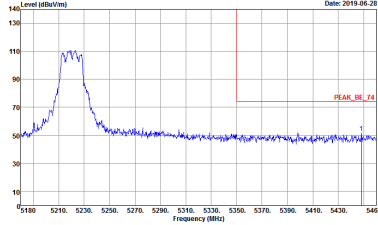
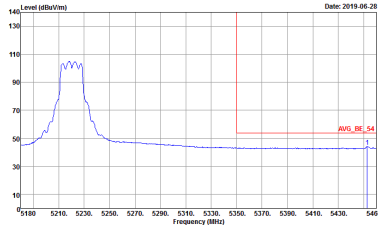

WIFI	Band 1 5150~5250MHz Band Edge @ 3m	
ANT	802.11a CH44 5220MHz - R	
1+2	Horizontal	Fundamental
<p>Peak</p>	 <p>Site : 03CH2-HY Condition : PEAK_BE_74 3m HORN_9120D_1328 HORIZONTAL Detector : Peak Project : 952409 Mode : 2 Setting : 16.5</p>	<p>Left blank</p>
<p>Avg.</p>	 <p>Site : 03CH2-HY Condition : AVG_BE_54 3m HORN_9120D_1328 HORIZONTAL Detector : Peak Project : 952409 Mode : 2 Setting : 16.5</p>	<p>Left blank</p>



WIFI	Band 1 5150~5250MHz Band Edge @ 3m	
ANT	802.11a CH44 5220MHz - L	
1+2	Vertical	Fundamental
Peak	<p>Site : 03CH2-11Y Condition : PEAK_BE_74 3m HORN_9120D_1328 VERTICAL RBW:3000.000KHz VBW:3000.000KHz SWT:Auto Detector : Peak Project : 952409 Mode : 2 Setting : 16.5</p>	<p>Site : 03CH2-11Y Condition : PEAK(FUND) 3m HORN_9120D_1328 VERTICAL RBW:3000.000KHz VBW:3000.000KHz SWT:Auto Detector : Peak Project : 952409 Mode : 2 Setting : 16.5</p>
Avg.	<p>Site : 03CH2-11Y Condition : AVG_BE_54 3m HORN_9120D_1328 VERTICAL RBW:3000.000KHz VBW:1.000KHz SWT:Auto Detector : Peak Project : 952409 Mode : 2 Setting : 16.5</p>	Left blank

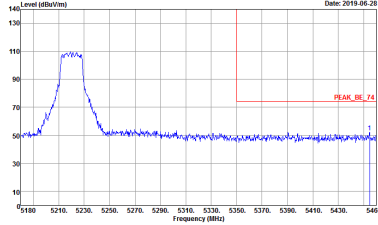
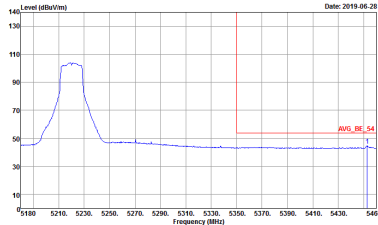

WIFI	Band 1 5150~5250MHz Band Edge @ 3m	
ANT	802.11a CH44 5220MHz - R	
1+2	Vertical	Fundamental
<p>Peak</p>	 <p>Site : 03CH2-HY Condition : PEAK_BE_74 3m HORN_9120D_1328 VERTICAL RBW:10000000Hz VBW:3000.0000Hz SWT:Auto Detector : Peak Project : 952409 Mode : 2 Setting : 16.5</p>	<p>Left blank</p>
<p>Avg.</p>	 <p>Site : 03CH2-HY Condition : AVG_BE_54 3m HORN_9120D_1328 VERTICAL RBW:10000000Hz VBW:1.0000Hz SWT:Auto Detector : Peak Project : 952409 Mode : 2 Setting : 16.5</p>	<p>Left blank</p>



WIFI	Band 1 5150~5250MHz Band Edge @ 3m	
ANT	802.11a CH48 5240MHz - L	
1+2	Horizontal	Fundamental
Peak	<p>Site : 03CH2-11Y Condition : PEAK_8C_74 3m HORN_9120D_1328 HORIZONTAL Detector : Peak Project : 952409 Mode : 3 Setting : 16.5</p>	<p>Site : 03CH2-11Y Condition : PEAK(UNL) 3m HORN_9120D_1328 HORIZONTAL Detector : Peak Project : 952409 Mode : 3 Setting : 16.5</p>
Avg.	<p>Site : 03CH2-11Y Condition : AVG_BE_14 3m HORN_9120D_1328 HORIZONTAL Detector : Peak Project : 952409 Mode : 3 Setting : 16.5</p>	Left blank

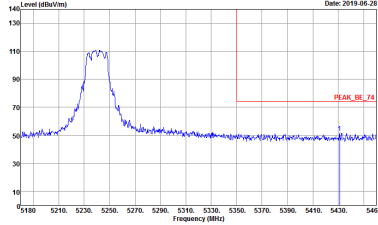
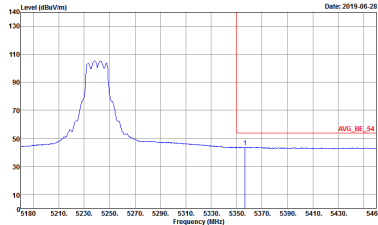

WIFI	Band 1 5150~5250MHz Band Edge @ 3m	
ANT	802.11a CH48 5240MHz - R	
1+2	Horizontal	Fundamental
<p>Peak</p>	 <p>Site : 03CH2-HY Condition : PEAK_BE_74 3m HORN_9120D_1328 HORIZONTAL Detector : Peak Project : 952409 Mode : 3 Setting : 16.5</p>	<p>Left blank</p>
<p>Avg.</p>	 <p>Site : 03CH2-HY Condition : AVG_BE_54 3m HORN_9120D_1328 HORIZONTAL Detector : Peak Project : 952409 Mode : 3 Setting : 16.5</p>	<p>Left blank</p>



WIFI	Band 1 5150~5250MHz Band Edge @ 3m	
ANT	802.11a CH48 5240MHz - L	
1+2	Vertical	Fundamental
Peak	<p>Site : 03CH12-11Y Condition : PEAK_8C_74 3m HORN_9120D_1328 VERTICAL RBW:3000.000KHz VBW:3000.000KHz SWT:Auto Detector : Peak Project : 952409 Mode : 3 Setting : 16.5</p>	<p>Site : 03CH12-11Y Condition : PEAK(UNL1) 3m HORN_9120D_1328 VERTICAL RBW:3000.000KHz VBW:3000.000KHz SWT:Auto Detector : Peak Project : 952409 Mode : 3 Setting : 16.5</p>
Avg.	<p>Site : 03CH12-11Y Condition : AVG_BE_1A 3m HORN_9120D_1328 VERTICAL RBW:3000.000KHz VBW:1000KHz SWT:Auto Detector : Peak Project : 952409 Mode : 3 Setting : 16.5</p>	Left blank



WIFI	Band 1 5150~5250MHz Band Edge @ 3m	
ANT	802.11a CH48 5240MHz - R	
1+2	Vertical	Fundamental
Peak	<p>Site : 03CH2-HY Condition : PEAK_BE_74 3m HORN_9120D_1328 VERTICAL Detector : Peak Project : 952409 Mode : 3 Setting : 16.5</p>	Left blank
Avg.	<p>Site : 03CH2-HY Condition : AVG_BE_54 3m HORN_9120D_1328 VERTICAL Detector : Peak Project : 952409 Mode : 3 Setting : 16.5</p>	Left blank

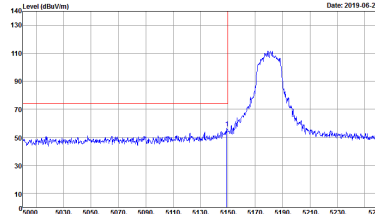
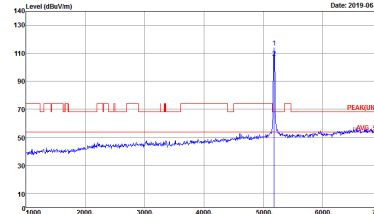
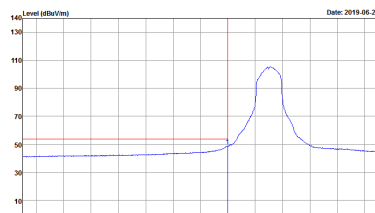

Band 1 5150~5250MHz
WIFI 802.11ac VHT20 (Band Edge @ 3m)

WIFI	Band 1 5150~5250MHz Band Edge @ 3m	
ANT	802.11ac VHT20 CH36 5180MHz	
1+2	Horizontal	Fundamental
<p>Peak</p>	 <p>Site : 03CH12-HY Condition : PEAK_BE_74 3m HORN_9120D_1328 HORIZONTAL RBW:1000.000KHz VBW:3000.000KHz SWT:Auto Detector : Peak Project : 952409 Mode : 4 Setting : 17</p>	 <p>Site : 03CH12-HY Condition : PEAK(UNIT1) 3m HORN_9120D_1328 HORIZONTAL RBW:1000.000KHz VBW:3000.000KHz SWT:Auto Detector : Peak Project : 952409 Mode : 4 Setting : 17</p>
<p>Avg.</p>	 <p>Site : 03CH12-HY Condition : AVG_BE_54 3m HORN_9120D_1328 HORIZONTAL RBW:1000.000KHz VBW:1.000KHz SWT:Auto Detector : Peak Project : 952409 Mode : 4 Setting : 17</p>	<p>Left blank</p>



WIFI	Band 1 5150~5250MHz Band Edge @ 3m	
ANT	802.11ac VHT20 CH36 5180MHz	
1+2	Vertical	Fundamental
Peak	<p>Site : 03CH2-11Y Condition : PEAK_9C_74 3m HORN_9120D_1328 VERTICAL RBW:3000.000KHz VBW:3000.000KHz SWT:Auto Detector : Peak Project : 952409 Mode : 4 Setting : 17</p>	<p>Site : 03CH2-11Y Condition : PEAK(UNIT) 3m HORN_9120D_1328 VERTICAL RBW:3000.000KHz VBW:3000.000KHz SWT:Auto Detector : Peak Project : 952409 Mode : 4 Setting : 17</p>
Avg.	<p>Site : 03CH2-11Y Condition : AVG_BE_1A 3m HORN_9120D_1328 VERTICAL RBW:3000.000KHz VBW:1000KHz SWT:Auto Detector : Peak Project : 952409 Mode : 4 Setting : 17</p>	Left blank

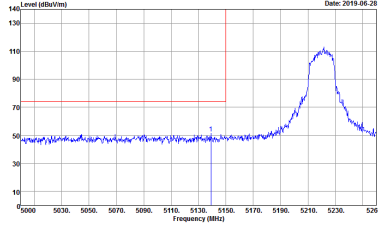
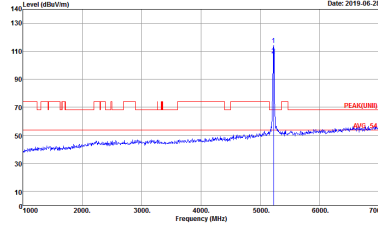
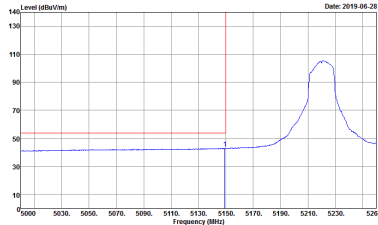

WIFI	Band 1 5150~5250MHz Band Edge @ 3m	
ANT	802.11ac VHT20 CH44 5220MHz - L	
1+2	Horizontal	Fundamental
<p>Peak</p>	 <p>Site : 03CH2-1Y Condition : PEAK_8C_74 3m HORN_9120D_1328 HORIZONTAL RBW:3000.000KHz VBW:3000.000KHz SWT:Auto Detector : Peak Project : 952409 Mode : 5 Setting : 17</p>	 <p>Site : 03CH2-1Y Condition : PEAK(UNL) 3m HORN_9120D_1328 HORIZONTAL RBW:3000.000KHz VBW:3000.000KHz SWT:Auto Detector : Peak Project : 952409 Mode : 5 Setting : 17</p>
<p>Avg.</p>	 <p>Site : 03CH2-1Y Condition : AVG_BE_54 3m HORN_9120D_1328 HORIZONTAL RBW:3000.000KHz VBW:1000KHz SWT:Auto Detector : Peak Project : 952409 Mode : 5 Setting : 17</p>	<p>Left blank</p>

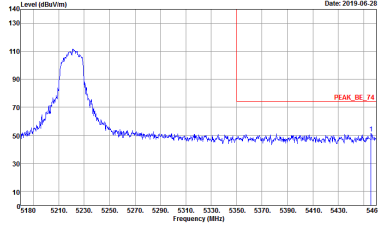
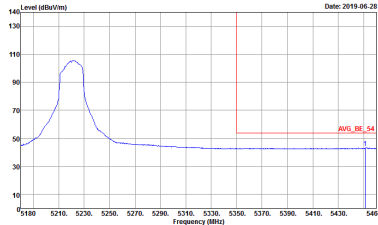

WIFI	Band 1 5150~5250MHz Band Edge @ 3m	
ANT	802.11ac VHT20 CH44 5220MHz - R	
1+2	Horizontal	Fundamental
<p>Peak</p>	 <p>Site : 03CH2-HY Condition : PEAK_BE_74 3m HORN_9120D_1328 HORIZONTAL Detector : Peak Project : 952409 Mode : 5 Setting : 17</p>	<p>Left blank</p>
<p>Avg.</p>	 <p>Site : 03CH2-HY Condition : AVG_BE_54 3m HORN_9120D_1328 HORIZONTAL Detector : Peak Project : 952409 Mode : 5 Setting : 17</p>	<p>Left blank</p>

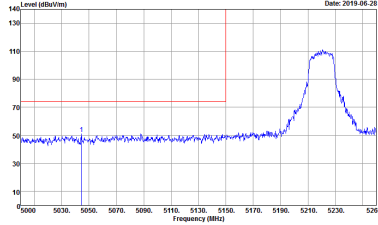
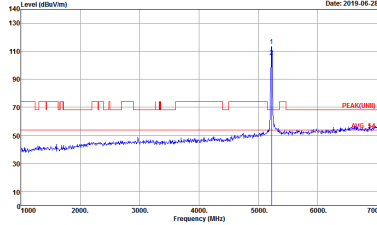
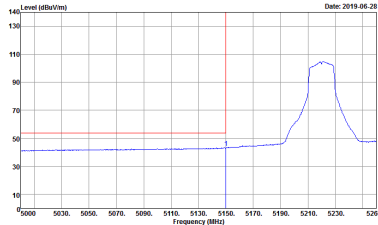

WIFI	Band 1 5150~5250MHz Band Edge @ 3m	
ANT	802.11ac VHT20 CH44 5220MHz - L	
1+2	Vertical	Fundamental
Peak	 <p>Site : 03CH2-11Y Condition : PEAK_BE_74 3m HORN_9120D_1328 VERTICAL RBW:3000.000KHz VBW:3000.000KHz SWT:Auto Detector : Peak Project : 952409 Mode : 5 Setting : 17</p>	 <p>Site : 03CH2-11Y Condition : PEAK(UNL) 3m HORN_9120D_1328 VERTICAL RBW:3000.000KHz VBW:3000.000KHz SWT:Auto Detector : Peak Project : 952409 Mode : 5 Setting : 17</p>
Avg.	 <p>Site : 03CH2-11Y Condition : AVG_BE_54 3m HORN_9120D_1328 VERTICAL RBW:3000.000KHz VBW:1000KHz SWT:Auto Detector : Peak Project : 952409 Mode : 5 Setting : 17</p>	Left blank

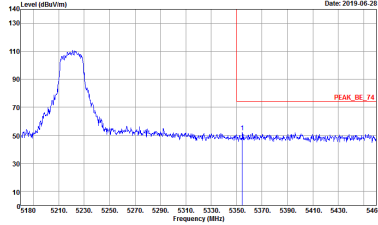
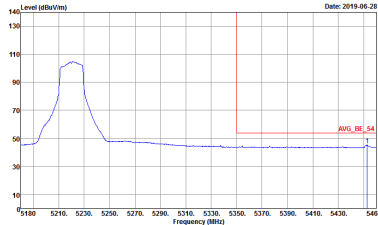

WIFI	Band 1 5150~5250MHz Band Edge @ 3m	
ANT	802.11ac VHT20 CH44 5220MHz - R	
1+2	Vertical	Fundamental
<p>Peak</p>	 <p>Site : 03CH2-HY Condition : PEAK_BE_74 3m HORN_9120D_1328 VERTICAL RBW:10000000Hz VBW:3000000Hz SWT:Auto Detector : Peak Project : 952409 Mode : 5 Setting : 17</p>	<p>Left blank</p>
<p>Avg.</p>	 <p>Site : 03CH2-HY Condition : AVG_BE_54 3m HORN_9120D_1328 VERTICAL RBW:10000000Hz VBW:10000Hz SWT:Auto Detector : Peak Project : 952409 Mode : 5 Setting : 17</p>	<p>Left blank</p>

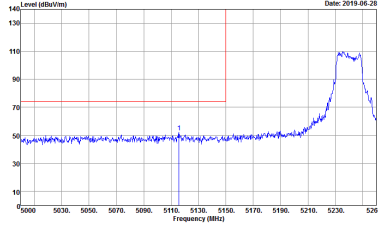
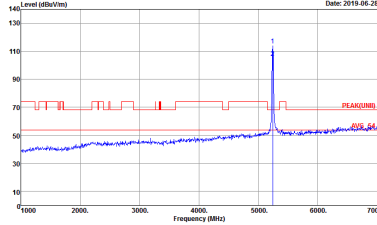
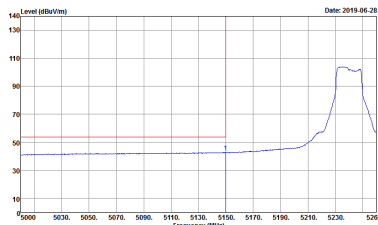

WIFI	Band 1 5150~5250MHz Band Edge @ 3m	
ANT	802.11ac VHT20 CH48 5240MHz - L	
1+2	Horizontal	Fundamental
<p>Peak</p>	 <p>Site : 03CH2-11Y Condition : PEAK_9C_74 3m HORN_9120D_1328 HORIZONTAL Detector : Peak Project : 952409 Mode : 6 Setting : 17</p>	 <p>Site : 03CH2-11Y Condition : PEAK(UNL) 3m HORN_9120D_1328 HORIZONTAL Detector : Peak Project : 952409 Mode : 6 Setting : 17</p>
<p>Avg.</p>	 <p>Site : 03CH2-11Y Condition : AVG_BE_14 3m HORN_9120D_1328 HORIZONTAL Detector : Peak Project : 952409 Mode : 6 Setting : 17</p>	<p>Left blank</p>

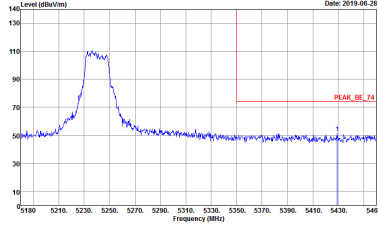
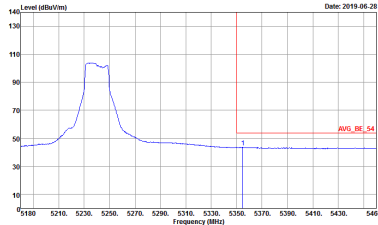

WIFI	Band 1 5150~5250MHz Band Edge @ 3m	
ANT	802.11ac VHT20 CH48 5240MHz - R	
1+2	Horizontal	Fundamental
<p>Peak</p>	 <p>Site : 03CH2-HY Condition : PEAK_BE_74 3m HORN_9120D_1328 HORIZONTAL Detector : Peak Project : 952409 Mode : 0 Setting : 17</p>	<p>Left blank</p>
<p>Avg.</p>	 <p>Site : 03CH2-HY Condition : AVG_BE_54 3m HORN_9120D_1328 HORIZONTAL Detector : Peak Project : 952409 Mode : 0 Setting : 17</p>	<p>Left blank</p>

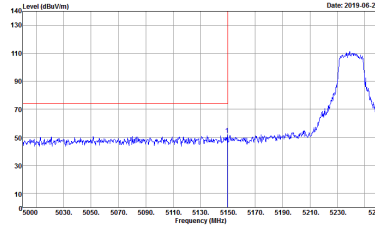
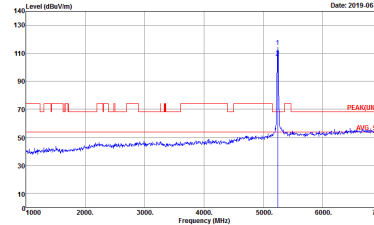
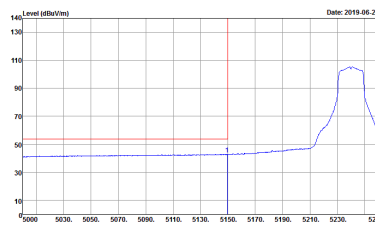

WIFI	Band 1 5150~5250MHz Band Edge @ 3m	
ANT	802.11ac VHT20 CH48 5240MHz - L	
1+2	Vertical	Fundamental
Peak	 <p>Site : 03CH12-11Y Condition : PEAK_BE_74 3m HORN_9120D_1328 VERTICAL RBW:3000.000KHz VBW:3000.000KHz SWT:Auto Detector : Peak Project : 952409 Mode : 6 Setting : 17</p>	 <p>Site : 03CH12-11Y Condition : PEAK(UNL) 3m HORN_9120D_1328 VERTICAL RBW:3000.000KHz VBW:3000.000KHz SWT:Auto Detector : Peak Project : 952409 Mode : 6 Setting : 17</p>
Avg.	 <p>Site : 03CH12-11Y Condition : AVG_BE_54 3m HORN_9120D_1328 VERTICAL RBW:3000.000KHz VBW:1000KHz SWT:Auto Detector : Peak Project : 952409 Mode : 6 Setting : 17</p>	Left blank

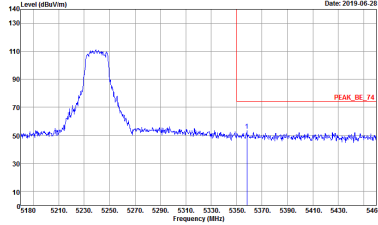
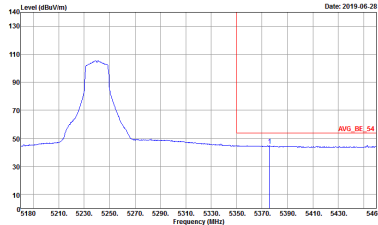

WIFI	Band 1 5150~5250MHz Band Edge @ 3m	
ANT	802.11ac VHT20 CH48 5240MHz - R	
1+2	Vertical	Fundamental
<p>Peak</p>	 <p>Site : 03CH2-HY Condition : PEAK_BE_74 3m HORN_9120D_1328 VERTICAL RBW:1000.000KHz VBW:3000.000KHz SWT:Auto Detector : Peak Project : 952409 Mode : 0 Setting : 17</p>	<p>Left blank</p>
<p>Avg.</p>	 <p>Site : 03CH2-HY Condition : AVG_BE_54 3m HORN_9120D_1328 VERTICAL RBW:1000.000KHz VBW:1.000KHz SWT:Auto Detector : Peak Project : 952409 Mode : 0 Setting : 17</p>	<p>Left blank</p>

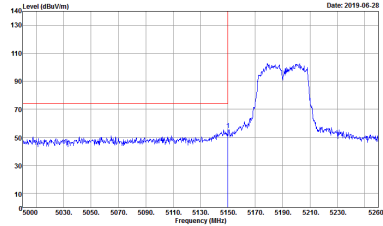
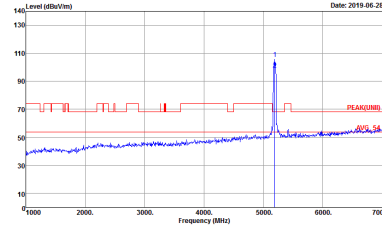
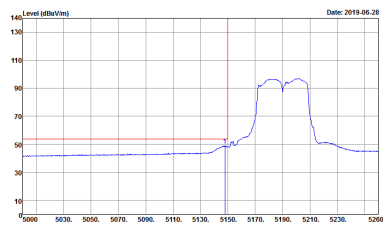

Band 1 5150~5250MHz
WIFI 802.11ac VHT40 (Band Edge @ 3m)

WIFI	Band 1 5150~5250MHz Band Edge @ 3m	
ANT	802.11ac VHT40 CH38 5190MHz - L	
1+2	Horizontal	Fundamental
<p>Peak</p>	 <p>Date: 2019.06.28</p> <p>Site : 03CH12-HY Condition : PEAK_BE_74 3m HORN_9120D_1328 HORIZONTAL RBW:3000.000KHz VBW:3000.000KHz SWT:Auto Detector : Peak Project : 952409 Mode : 7 Setting : 11.5</p>	 <p>Date: 2019.06.28</p> <p>Site : 03CH12-HY Condition : PEAK(UNIT1) 3m HORN_9120D_1328 HORIZONTAL RBW:3000.000KHz VBW:3000.000KHz SWT:Auto Detector : Peak Project : 952409 Mode : 7 Setting : 11.5</p>
<p>Avg.</p>	 <p>Date: 2019.06.28</p> <p>Site : 03CH12-HY Condition : AVG_BE_54 3m HORN_9120D_1328 HORIZONTAL RBW:3000.000KHz VBW:3.000KHz SWT:Auto Detector : Peak Project : 952409 Mode : 7 Setting : 11.5</p>	<p>Left blank</p>

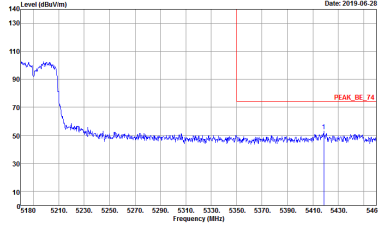
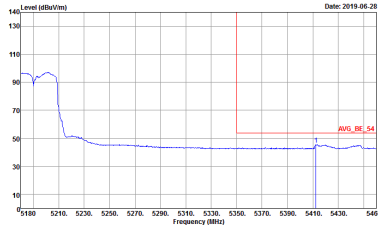

WIFI	Band 1 5150~5250MHz Band Edge @ 3m	
ANT	802.11ac VHT40 CH38 5190MHz - R	
1+2	Horizontal	Fundamental
<p>Peak</p>	 <p>Site : 03CH2-HY Condition : PEAK_BE_74 3m HORN_9120D_1328 HORIZONTAL Detector : Peak Project : 952409 Mode : 7 Setting : 11.5</p>	<p>Left blank</p>
<p>Avg.</p>	 <p>Site : 03CH2-HY Condition : AVG_BE_54 3m HORN_9120D_1328 HORIZONTAL Detector : Peak Project : 952409 Mode : 7 Setting : 11.5</p>	<p>Left blank</p>

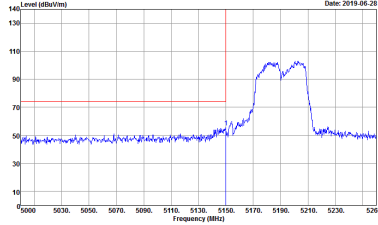
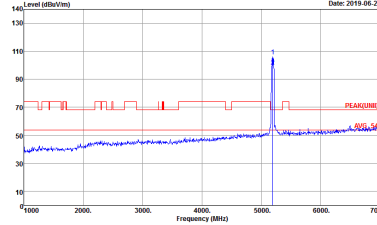

WIFI	Band 1 5150~5250MHz Band Edge @ 3m	
ANT	802.11ac VHT40 CH38 5190MHz - L	
1+2	Vertical	Fundamental
Peak	 <p>Site : 03CH12-11Y Condition : PEAK_BE_74 3m HORN_9120D_1328 VERTICAL RBW:3000.000KHz VBW:3000.000KHz SWT:Auto Detector : Peak Project : 952409 Mode : 7 Setting : 11.5</p>	 <p>Site : 03CH12-11Y Condition : PEAK(UNL1) 3m HORN_9120D_1328 VERTICAL RBW:3000.000KHz VBW:3000.000KHz SWT:Auto Detector : Peak Project : 952409 Mode : 7 Setting : 11.5</p>
Avg.	 <p>Site : 03CH12-11Y Condition : AVG_BE_54 3m HORN_9120D_1328 VERTICAL RBW:3000.000KHz VBW:3000.000KHz SWT:Auto Detector : Peak Project : 952409 Mode : 7 Setting : 11.5</p>	Left blank



WIFI	Band 1 5150~5250MHz Band Edge @ 3m	
ANT	802.11ac VHT40 CH38 5190MHz - R	
1+2	Vertical	Fundamental
Peak	<p>Site : 03CH2-HY Condition : PEAK_BE_74 3m HORN_9120D_1328 VERTICAL RBW:10000000Hz VBW:3000000Hz SWT:Auto Detector : Peak Project : 952409 Mode : 7 Setting : 11.5</p>	Left blank
Avg.	<p>Site : 03CH2-HY Condition : AVG_BE_54 3m HORN_9120D_1328 VERTICAL RBW:10000000Hz VBW:3000000Hz SWT:Auto Detector : Peak Project : 952409 Mode : 7 Setting : 11.5</p>	Left blank

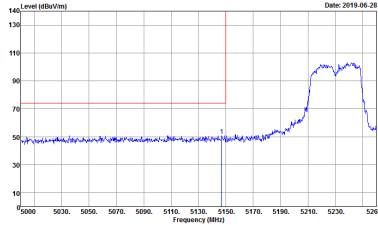
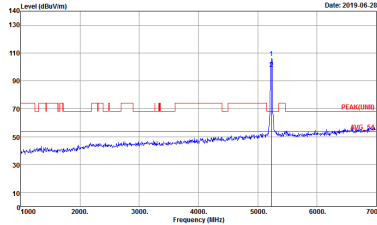
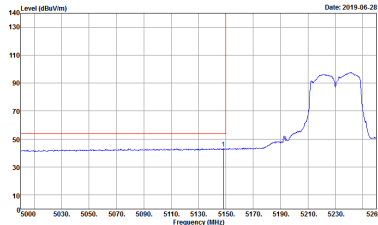

WIFI	Band 1 5150~5250MHz Band Edge @ 3m	
ANT	802.11ac VHT40 CH46 5230MHz - L	
1+2	Horizontal	Fundamental
<p>Peak</p>	 <p>Site : 03CH12-HY Condition : PEAK_BE_74 3m HORN_9120D_1328 HORIZONTAL Detector : Peak Project : 952409 Mode : 8 Setting : 11.5</p>	 <p>Site : 03CH12-HY Condition : PEAK(FUNDE) 3m HORN_9120D_1328 HORIZONTAL Detector : Peak Project : 952409 Mode : 8 Setting : 11.5</p>
<p>Avg.</p>	 <p>Site : 03CH12-HY Condition : AVG_BE_54 3m HORN_9120D_1328 HORIZONTAL Detector : Peak Project : 952409 Mode : 8 Setting : 11.5</p>	<p>Left blank</p>

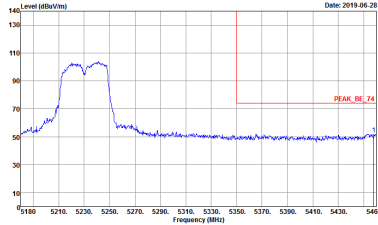
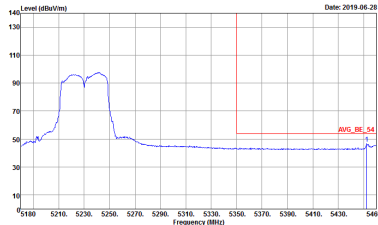

WIFI	Band 1 5150~5250MHz Band Edge @ 3m	
ANT	802.11ac VHT40 CH46 5230MHz - R	
1+2	Horizontal	Fundamental
<p>Peak</p>	 <p>Site : 03CH12-HY Condition : PEAK_BE_74 3m HORN_9120D_132R HORIZONTAL Detector : Peak Project : 952409 Mode : 8 Setting : 11.5</p>	<p>Left blank</p>
<p>Avg.</p>	 <p>Site : 03CH12-HY Condition : AVG_BE_54 3m HORN_9120D_132R HORIZONTAL Detector : Peak Project : 952409 Mode : 8 Setting : 11.5</p>	<p>Left blank</p>

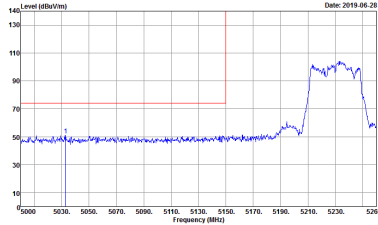
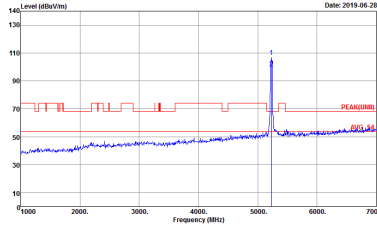
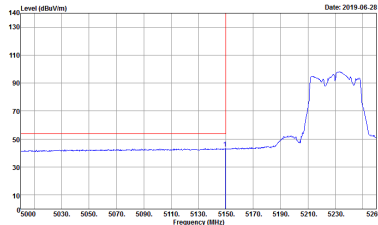

WIFI	Band 1 5150~5250MHz Band Edge @ 3m	
ANT	802.11ac VHT40 CH46 5230MHz - L	
1+2	Vertical	Fundamental
<p>Peak</p>	 <p>Site : 03CH12-HY Condition : PEAK_BE_74 3m HORN_9120D_1328 VERTICAL Detector : Peak Project : 952409 Mode : 8 Setting : 11.5</p>	 <p>Site : 03CH12-HY Condition : PEAK(FUNDE) 3m HORN_9120D_1328 VERTICAL Detector : Peak Project : 952409 Mode : 8 Setting : 11.5</p>
<p>Avg.</p>	 <p>Site : 03CH12-HY Condition : AVG_BE_54 3m HORN_9120D_1328 VERTICAL Detector : Peak Project : 952409 Mode : 8 Setting : 11.5</p>	<p>Left blank</p>

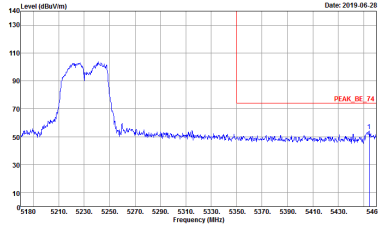
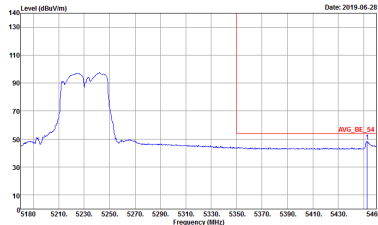

WIFI	Band 1 5150~5250MHz Band Edge @ 3m	
ANT	802.11ac VHT40 CH46 5230MHz - R	
1+2	Vertical	Fundamental
Peak	 <p>Site : 03CH12-HY Condition : PEAK_BE_74 3m HORN_9120D_1328 VERTICAL Detector : Peak Project : 952409 Mode : 8 Setting : 11.5</p>	Left blank
Avg.	 <p>Site : 03CH12-HY Condition : AVG_BE_54 3m HORN_9120D_1328 VERTICAL Detector : Peak Project : 952409 Mode : 8 Setting : 11.5</p>	Left blank

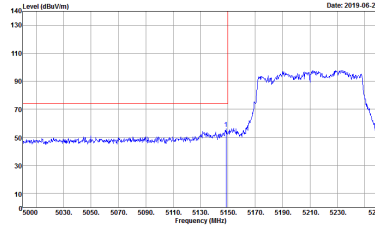
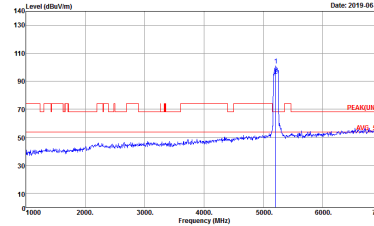
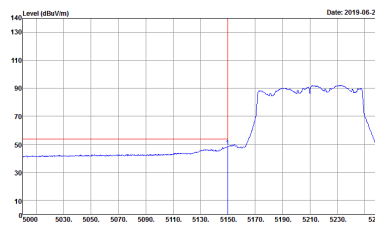

Band 1 5150~5250MHz
WIFI 802.11ac VHT80 (Band Edge @ 3m)

WIFI	Band 1 5150~5250MHz Band Edge @ 3m	
ANT	802.11ac VHT80 CH42 5210MHz - L	
1+2	Horizontal	Fundamental
<p>Peak</p>	 <p>Site : 03CH12-HY Condition : PEAK_BE_74 3m HORN_9120D_1328 HORIZONTAL RBW:3000.000KHz VBW:3000.000KHz SWT:Auto Detector : Peak Project : 952409 Mode : 9 Setting : 9.5</p>	 <p>Site : 03CH12-HY Condition : PEAK(UNIT1) 3m HORN_9120D_1328 HORIZONTAL RBW:3000.000KHz VBW:3000.000KHz SWT:Auto Detector : Peak Project : 952409 Mode : 9 Setting : 9.5</p>
<p>Avg.</p>	 <p>Site : 03CH12-HY Condition : AVG_BE_54 3m HORN_9120D_1328 HORIZONTAL RBW:3000.000KHz VBW:3000.000KHz SWT:Auto Detector : Peak Project : 952409 Mode : 9 Setting : 9.5</p>	<p>Left blank</p>

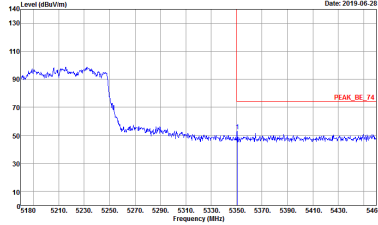
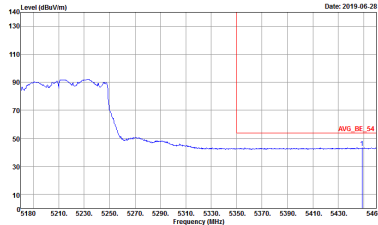

WIFI	Band 1 5150~5250MHz Band Edge @ 3m	
ANT	802.11ac VHT80 CH42 5210MHz - R	
1+2	Horizontal	Fundamental
<p>Peak</p>	 <p>Site : 03CH2-HY Condition : PEAK_BE_74 3m HORN_9120D_1328 HORIZONTAL RBW:1000.000kHz VBW:3000.000kHz SWT:Auto Detector : Peak Project : 952409 Mode : 9 Setting : 9.5</p>	<p>Left blank</p>
<p>Avg.</p>	 <p>Site : 03CH2-HY Condition : AVG_BE_54 3m HORN_9120D_1328 HORIZONTAL RBW:1000.000kHz VBW:3.000kHz SWT:Auto Detector : Peak Project : 952409 Mode : 9 Setting : 9.5</p>	<p>Left blank</p>

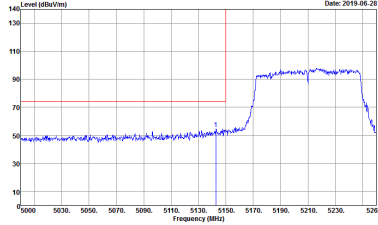
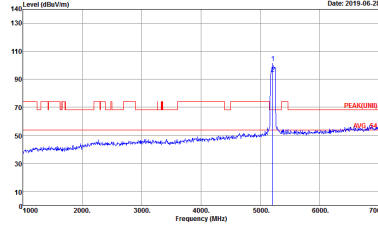
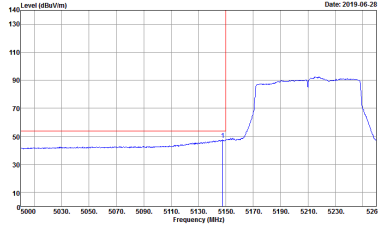

WIFI	Band 1 5150~5250MHz Band Edge @ 3m	
ANT	802.11ac VHT80 CH42 5210MHz - L	
1+2	Vertical	Fundamental
Peak	 <p>Site : 03CH2-11Y Condition : PEAK_BE_74 3m HORN_9120D_1328 VERTICAL RBW:3000.000KHz VBW:3000.000KHz SWT:Auto Detector : Peak Project : 952409 Mode : 9 Setting : 9.5</p>	 <p>Site : 03CH2-11Y Condition : PEAK(UNL1) 3m HORN_9120D_1328 VERTICAL RBW:3000.000KHz VBW:3000.000KHz SWT:Auto Detector : Peak Project : 952409 Mode : 9 Setting : 9.5</p>
Avg.	 <p>Site : 03CH2-11Y Condition : AVG_BE_54 3m HORN_9120D_1328 VERTICAL RBW:3000.000KHz VBW:3000.000KHz SWT:Auto Detector : Peak Project : 952409 Mode : 9 Setting : 9.5</p>	Left blank

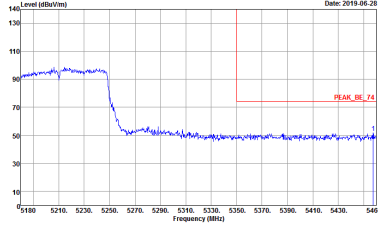
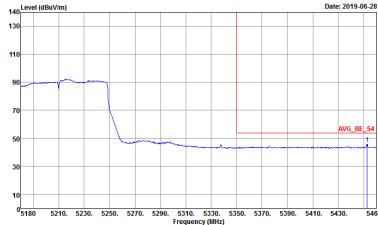

WIFI	Band 1 5150~5250MHz Band Edge @ 3m	
ANT	802.11ac VHT80 CH42 5210MHz - R	
1+2	Vertical	Fundamental
<p>Peak</p>	 <p>Site : 03CH2-HY Condition : PEAK_BE_74 3m HORN_9120D_1328 VERTICAL RBW:10000000Hz VBW:3000000Hz SWT:Auto Detector : Peak Project : 952409 Mode : 9 Setting : 9.5</p>	<p>Left blank</p>
<p>Avg.</p>	 <p>Site : 03CH2-HY Condition : AVG_BE_54 3m HORN_9120D_1328 VERTICAL RBW:10000000Hz VBW:3000000Hz SWT:Auto Detector : Peak Project : 952409 Mode : 9 Setting : 9.5</p>	<p>Left blank</p>



Band 1 - 5150~5250MHz
WIFI 802.11a (Harmonic @ 3m)

WIFI	Band 1 5150~5250MHz Harmonic @ 3m	
ANT	802.11a CH36 5180MHz	
1+2	Horizontal	Vertical
Peak Avg.	<p>Site : 03CH12-HY Condition : PEAK(UM) 3m HORN_9120D_1328 HORIZONTAL Detector : Peak Project : 952409 Mode : 1 Setting : 16.5</p>	<p>Site : 03CH12-HY Condition : PEAK(UM) 3m HORN_9120D_1328 VERTICAL Detector : Peak Project : 952409 Mode : 1 Setting : 16.5</p>

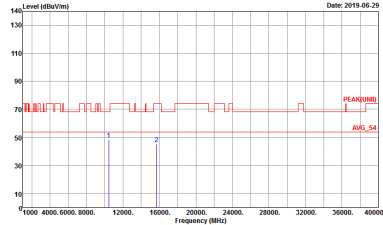
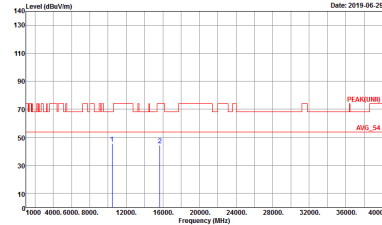

WIFI	Band 1 5150~5250MHz Harmonic @ 3m	
ANT	802.11a CH44 5220MHz	
1+2	Horizontal	Vertical
<p>Peak</p> <p>Avg.</p>	 <p>Site : 03CH12-1#Y Condition : PEAK(UNII) 3m HORN_9120D_1328 HORIZONTAL Detector : Peak Project : 952409 Mode : 2 Setting : 10.5</p>	 <p>Site : 03CH12-1#Y Condition : PEAK(UNII) 3m HORN_9120D_1328 VERTICAL Detector : Peak Project : 952409 Mode : 2 Setting : 10.5</p>

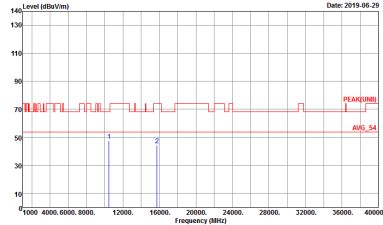
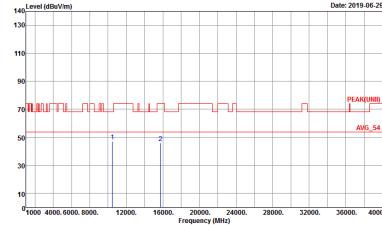

WIFI	Band 1 5150~5250MHz Harmonic @ 3m	
ANT	802.11a CH48 5240MHz	
1+2	Horizontal	Vertical
<p>Peak Avg.</p>	 <p>Site : 03CH12-1#V Condition : PEAK(UNII) 3m HORN_9120D_1328 HORIZONTAL Detector : Peak Project : 952409 Mode : 3 Setting : 10.5</p>	 <p>Site : 03CH12-1#V Condition : PEAK(UNII) 3m HORN_9120D_1328 VERTICAL Detector : Peak Project : 952409 Mode : 3 Setting : 10.5</p>



**Band 1 5150~5250MHz
WIFI 802.11ac VHT20 (Harmonic @ 3m)**

WIFI	Band 1 5150~5250MHz Harmonic @ 3m	
ANT	802.11ac VHT20 CH36 5180MHz	
1+2	Horizontal	Vertical
Peak Avg.	<p>Site : 03CH12-HY Condition : PEAK(UNII) 3m HORN_9120D_1328 HORIZONTAL Detector : Peak Project : 952409 Mode : 4 Setting : 17</p>	<p>Site : 03CH12-HY Condition : PEAK(UNII) 3m HORN_9120D_1328 VERTICAL Detector : Peak Project : 952409 Mode : 4 Setting : 17</p>

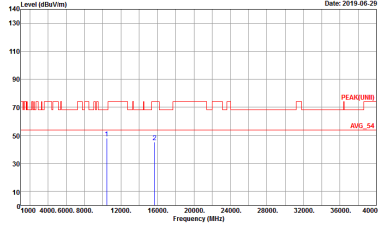
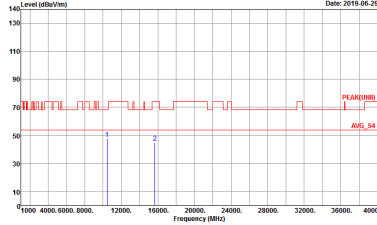

WIFI	Band 1 5150~5250MHz Harmonic @ 3m	
ANT	802.11ac VHT20 CH44 5220MHz	
1+2	Horizontal	Vertical
<p>Peak Avg.</p>	 <p>Site : 03CH12-11V Condition : PEAK(UNII) 3m HORN_9120D_1328 HORIZONTAL Detector : Peak Project : 952409 Mode : F Setting : 17</p>	 <p>Site : 03CH12-11V Condition : PEAK(UNII) 3m HORN_9120D_1328 VERTICAL Detector : Peak Project : 952409 Mode : F Setting : 17</p>



WIFI	Band 1 5150~5250MHz Harmonic @ 3m	
ANT	802.11ac VHT20 CH48 5240MHz	
1+2	Horizontal	Vertical
Peak Avg.	<p>Site : 03CHZ-11Y Condition : PEAK(UNII) 3m HORN_9120D_1328 HORIZONTAL Detector : Peak Project : 952409 Mode : 6 Setting : 17</p>	<p>Site : 03CHZ-11Y Condition : PEAK(UNII) 3m HORN_9120D_1328 VERTICAL Detector : Peak Project : 952409 Mode : 6 Setting : 17</p>



Band 1 5150~5250MHz
WIFI 802.11ac VHT40 (Harmonic @ 3m)

WIFI	Band 1 5150~5250MHz Harmonic @ 3m	
ANT	802.11ac VHT40 CH38 5190MHz	
1+2	Horizontal	Vertical
Peak Avg.	<p>Site : 03CH12-HY Condition : PEAK(UNII) 3m HORN_9120D_1328 HORIZONTAL Detector : Peak Project : 952409 Mode : 7 Setting : 11.5</p>	<p>Site : 03CH12-HY Condition : PEAK(UNII) 3m HORN_9120D_1328 VERTICAL Detector : Peak Project : 952409 Mode : 7 Setting : 11.5</p>



WIFI	Band 1 5150~5250MHz Harmonic @ 3m	
ANT	802.11ac VHT40 CH46 5230MHz	
1+2	Horizontal	Vertical
Peak Avg.	<p>Site : 03CH12-1#V Condition : PEAK(UNII) 3m HORN_9120D_1328 HORIZONTAL Detector : Peak Project : 952409 Mode : S Setting : 11.5</p>	<p>Site : 03CH12-1#V Condition : PEAK(UNII) 3m HORN_9120D_1328 VERTICAL Detector : Peak Project : 952409 Mode : S Setting : 11.5</p>



Band 1 5150~5250MHz
WIFI 802.11ac VHT80 (Harmonic @ 3m)

WIFI	Band 1 5150~5250MHz Harmonic @ 3m	
ANT	802.11ac VHT80 CH42 5210MHz	
1+2	Horizontal	Vertical
Peak Avg.	<p>Site : 03CH12-HY Condition : PEAK(UNII) 3m HORN_9120D_1328 HORIZONTAL Detector : Peak Project : 952409 Mode : 9 Setting : -9.5</p>	<p>Site : 03CH12-HY Condition : PEAK(UNII) 3m HORN_9120D_1328 VERTICAL Detector : Peak Project : 952409 Mode : 9 Setting : -9.5</p>



Band 2 - 5250~5350MHz
WIFI 802.11a (Band Edge @ 3m)

WIFI	Band 2 5250~5350MHz Band Edge @ 3m	
ANT	802.11a CH52 5260MHz - L	
1+2	Horizontal	Fundamental
Peak	<p>Site : 03CHIZ-HY Condition : PEAK_BE_74 3m HORN_9120D_1328 HORIZONTAL RBW:1000.000kHz VBW:3000.000kHz SWT:Auto Detector : Peak Project : 952409 Mode : I0 Setting : 16.5</p>	<p>Site : 03CHIZ-HY Condition : PEAK(FUND) 3m HORN_9120D_1328 HORIZONTAL RBW:1000.000kHz VBW:3000.000kHz SWT:Auto Detector : Peak Project : 952409 Mode : I0 Setting : 16.5</p>
Avg.	<p>Site : 03CHIZ-HY Condition : AVG_BE_54 3m HORN_9120D_1328 HORIZONTAL RBW:1000.000kHz VBW:1.000kHz SWT:Auto Detector : Peak Project : 952409 Mode : I0 Setting : 16.5</p>	Left blank

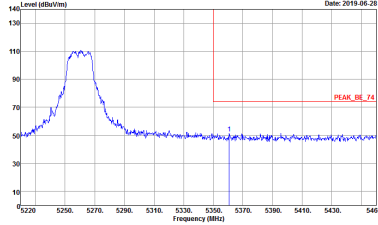
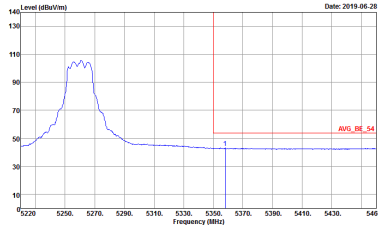

WIFI	Band 2 5250~5350MHz Band Edge @ 3m	
ANT	802.11a CH52 5260MHz - R	
1+2	Horizontal	Fundamental
<p>Peak</p>	 <p>Site : 03CH2-HY Condition : PEAK_BE_74 3m HORN_9120D_1328 HORIZONTAL Detector : Peak Project : 952409 Mode : 10 Setting : 16.5</p>	<p>Left blank</p>
<p>Avg.</p>	 <p>Site : 03CH2-HY Condition : AVG_BE_54 3m HORN_9120D_1328 HORIZONTAL Detector : Peak Project : 952409 Mode : 10 Setting : 16.5</p>	<p>Left blank</p>

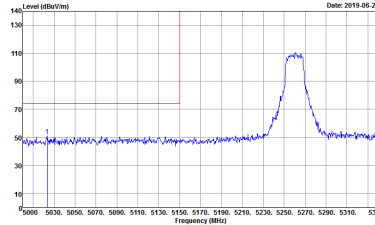
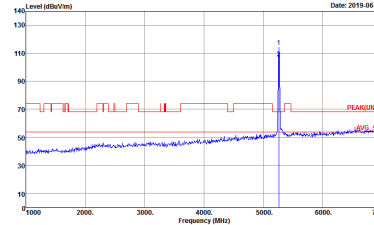
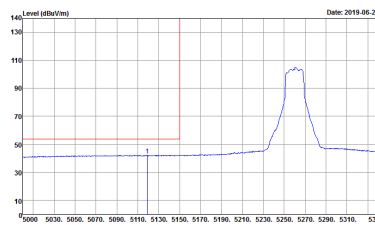

WIFI	Band 2 5250~5350MHz Band Edge @ 3m	
ANT	802.11a CH52 5260MHz - L	
1+2	Vertical	Fundamental
Peak	 <p>Date: 2019-06-28</p> <p>Site : 03CH12-11Y Condition : PEAK_9C_74 3m HORN_9120D_1328 VERTICAL RBW:3000.000KHz VBW:3000.000KHz SWT:Auto Detector : Peak Project : 952409 Mode : 10 Setting : 16.5</p>	 <p>Date: 2019-06-28</p> <p>Site : 03CH12-11Y Condition : PEAK(UNL) 3m HORN_9120D_1328 VERTICAL RBW:3000.000KHz VBW:3000.000KHz SWT:Auto Detector : Peak Project : 952409 Mode : 10 Setting : 16.5</p>
Avg.	 <p>Date: 2019-06-28</p> <p>Site : 03CH12-11Y Condition : AVG_BE_1A 3m HORN_9120D_1328 VERTICAL RBW:3000.000KHz VBW:1.000KHz SWT:Auto Detector : Peak Project : 952409 Mode : 10 Setting : 16.5</p>	Left blank



WIFI	Band 2 5250~5350MHz Band Edge @ 3m	
ANT	802.11a CH52 5260MHz - R	
1+2	Vertical	Fundamental
Peak	<p>Site : 03CH2-HY Condition : PEAK_BE_74 3m HORN_9120D_1328 VERTICAL RBW:10000000Hz VBW:3000000Hz SWT:Auto Detector : Peak Project : 952409 Mode : 10 Setting : 16.5</p>	Left blank
Avg.	<p>Site : 03CH2-HY Condition : AVG_BE_54 3m HORN_9120D_1328 VERTICAL RBW:10000000Hz VBW:10000Hz SWT:Auto Detector : Peak Project : 952409 Mode : 10 Setting : 16.5</p>	Left blank

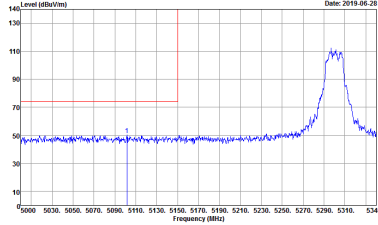
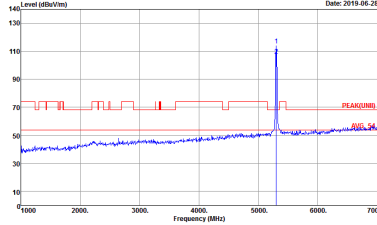
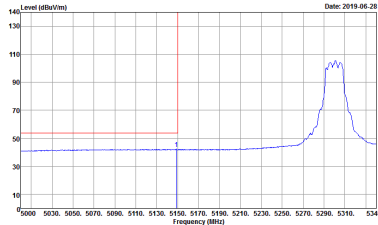

WIFI	Band 2 5250~5350MHz Band Edge @ 3m	
ANT	802.11a CH60 5300MHz - L	
1+2	Horizontal	Fundamental
Peak	 <p>Site : 03CH12-11Y Condition : PEAK_BE_74 3m HORN_9120D_1328 HORIZONTAL Detector : Peak Project : 952409 Mode : 11 Setting : 16.5</p>	 <p>Site : 03CH12-11Y Condition : PEAK(UN11) 3m HORN_9120D_1328 HORIZONTAL Detector : Peak Project : 952409 Mode : 11 Setting : 16.5</p>
Avg.	 <p>Site : 03CH12-11Y Condition : AVG_BE_54 3m HORN_9120D_1328 HORIZONTAL Detector : Peak Project : 952409 Mode : 11 Setting : 16.5</p>	Left blank

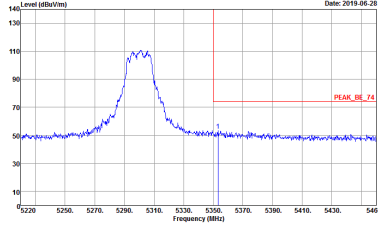
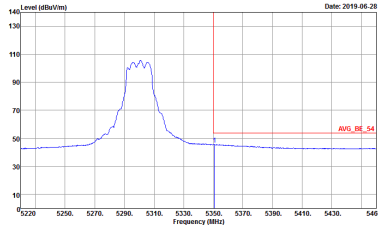

WIFI	Band 2 5250~5350MHz Band Edge @ 3m	
ANT	802.11a CH60 5300MHz - R	
1+2	Horizontal	Fundamental
<p>Peak</p>	 <p>Site : 03CH12-HY Condition : PEAK_BE_74 3m HORN_9120D_1328 HORIZONTAL Detector : Peak Project : 952409 Mode : 11 Setting : 16.5</p>	<p>Left blank</p>
<p>Avg.</p>	 <p>Site : 03CH12-HY Condition : AVG_BE_54 3m HORN_9120D_1328 HORIZONTAL Detector : Peak Project : 952409 Mode : 11 Setting : 16.5</p>	<p>Left blank</p>



WIFI	Band 2 5250~5350MHz Band Edge @ 3m	
ANT	802.11a CH60 5300MHz - L	
1+2	Vertical	Fundamental
Peak	<p>Site : 03CH12-11Y Condition : PEAK_BE_74 3m HORN_9120D_1328 VERTICAL RBW:3000.000KHz VBW:3000.000KHz SWT:Auto Detector : Peak Project : 952409 Mode : 11 Setting : 16.5</p>	<p>Site : 03CH12-11Y Condition : PEAK(FUND) 3m HORN_9120D_1328 VERTICAL RBW:3000.000KHz VBW:3000.000KHz SWT:Auto Detector : Peak Project : 952409 Mode : 11 Setting : 16.5</p>
Avg.	<p>Site : 03CH12-11Y Condition : AVG_BE_54 3m HORN_9120D_1328 VERTICAL RBW:3000.000KHz VBW:1.000KHz SWT:Auto Detector : Peak Project : 952409 Mode : 11 Setting : 16.5</p>	Left blank

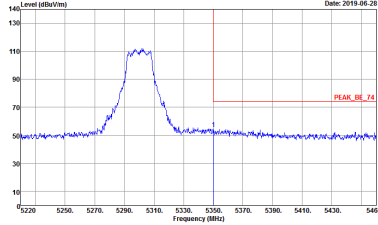
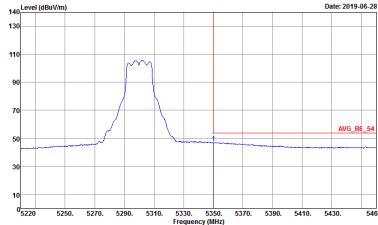

WIFI	Band 2 5250~5350MHz Band Edge @ 3m	
ANT	802.11a CH60 5300MHz - R	
1+2	Vertical	Fundamental
<p>Peak</p>	 <p>Site : 03CH2-YY Condition : PEAK_BE_74 3m HORN_9120D_1328 VERTICAL RBW:10000000Hz VBW:3000000Hz SWT:Auto Detector : Peak Project : 952409 Mode : 11 Setting : 16.5</p>	<p>Left blank</p>
<p>Avg.</p>	 <p>Site : 03CH2-YY Condition : AVG_BE_54 3m HORN_9120D_1328 VERTICAL RBW:10000000Hz VBW:10000Hz SWT:Auto Detector : Peak Project : 952409 Mode : 11 Setting : 16.5</p>	<p>Left blank</p>



WIFI	Band 2 5250~5350MHz Band Edge @ 3m	
ANT	802.11a CH64 5320MHz	
1+2	Horizontal	Fundamental
Peak	<p>Site : 03CH12-11Y Condition : PEAK_BE_74 3m HORN_9120D_1328 HORIZONTAL RBW:3000.000KHz VBW:3000.000KHz SWT:Auto Detector : Peak Project : 952409 Mode : 12 Setting : 16.5</p>	<p>Site : 03CH12-11Y Condition : PEAK(FUND) 3m HORN_9120D_1328 HORIZONTAL RBW:3000.000KHz VBW:3000.000KHz SWT:Auto Detector : Peak Project : 952409 Mode : 12 Setting : 16.5</p>
Avg.	<p>Site : 03CH12-11Y Condition : AVG_BE_54 3m HORN_9120D_1328 HORIZONTAL RBW:3000.000KHz VBW:1.000KHz SWT:Auto Detector : Peak Project : 952409 Mode : 12 Setting : 16.5</p>	Left blank



WIFI	Band 2 5250~5350MHz Band Edge @ 3m	
ANT	802.11a CH64 5320MHz	
1+2	Vertical	Fundamental
Peak	<p>Site : 03CH12-HY Condition : PEAK_BE_74 3m HORN_9120D_1328 VERTICAL RBW:3000.000KHz VBW:3000.000KHz SWT:Auto Detector : Peak Project : 952409 Mode : 12 Setting : 16.5</p>	<p>Site : 03CH12-HY Condition : PEAK(UNL) 3m HORN_9120D_1328 VERTICAL RBW:3000.000KHz VBW:3000.000KHz SWT:Auto Detector : Peak Project : 952409 Mode : 12 Setting : 16.5</p>
Avg.	<p>Site : 03CH12-HY Condition : AVG_BE_54 3m HORN_9120D_1328 VERTICAL RBW:3000.000KHz VBW:1000KHz SWT:Auto Detector : Peak Project : 952409 Mode : 12 Setting : 16.5</p>	Left blank



Band 2 5250~5350MHz
WIFI 802.11ac VHT20 (Band Edge @ 3m)

WIFI	Band 2 5250~5350MHz Band Edge @ 3m	
ANT	802.11ac VHT20 CH52 5260MHz - L	
1+2	Horizontal	Fundamental
Peak	<p>Site : 03CH12-HY Condition : PEAK_BE_74 3m HORN_9120D_1328 HORIZONTAL RBW:10000000kHz VBW:3000000kHz SWT:Auto Detector : Peak Project : 952409 Mode : 13 Setting : 17</p>	<p>Site : 03CH12-HY Condition : PEAK(UNIT1) 3m HORN_9120D_1328 HORIZONTAL RBW:10000000kHz VBW:3000000kHz SWT:Auto Detector : Peak Project : 952409 Mode : 13 Setting : 17</p>
Avg.	<p>Site : 03CH12-HY Condition : AVG_BE_54 3m HORN_9120D_1328 HORIZONTAL RBW:10000000kHz VBW:10000kHz SWT:Auto Detector : Peak Project : 952409 Mode : 13 Setting : 17</p>	Left blank

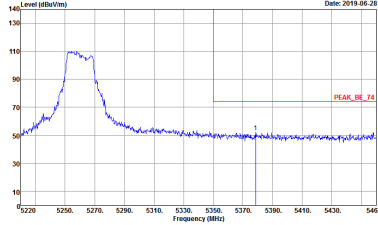
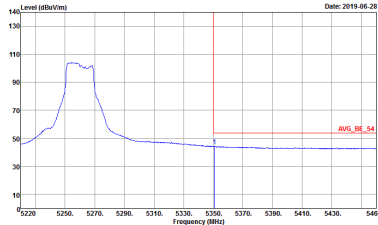

WIFI	Band 2 5250~5350MHz Band Edge @ 3m	
ANT	802.11ac VHT20 CH52 5260MHz - R	
1+2	Horizontal	Fundamental
<p>Peak</p>	 <p>Site : 03CH2-HY Condition : PEAK_BE_74 3m HORN_9120D_1328 HORIZONTAL RBW:10000000Hz VBW:3000000Hz SWT:Auto Detector : Peak Project : 952409 Mode : 13 Setting : 17</p>	<p>Left blank</p>
<p>Avg.</p>	 <p>Site : 03CH2-HY Condition : AVG_BE_54 3m HORN_9120D_1328 HORIZONTAL RBW:10000000Hz VBW:10000Hz SWT:Auto Detector : Peak Project : 952409 Mode : 13 Setting : 17</p>	<p>Left blank</p>

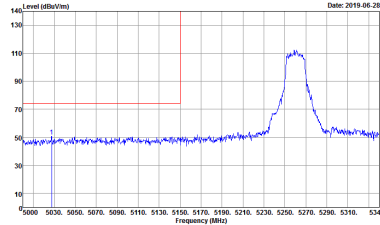
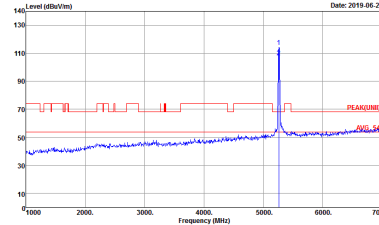
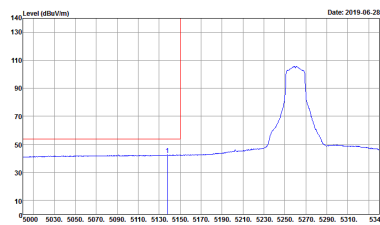

WIFI	Band 2 5250~5350MHz Band Edge @ 3m	
ANT	802.11ac VHT20 CH52 5260MHz - L	
1+2	Vertical	Fundamental
Peak	 <p>Site : 03CH2-11Y Condition : PEAK_BE_74 3m HORN_91200_1328 VERTICAL RBW:3000.000KHz VBW:3000.000KHz SWT:Auto Detector : Peak Project : 952409 Mode : 13 Setting : 17</p>	 <p>Site : 03CH2-11Y Condition : PEAK(FUND) 3m HORN_91200_1328 VERTICAL RBW:3000.000KHz VBW:3000.000KHz SWT:Auto Detector : Peak Project : 952409 Mode : 13 Setting : 17</p>
Avg.	 <p>Site : 03CH2-11Y Condition : AVG_BE_54 3m HORN_91200_1328 VERTICAL RBW:3000.000KHz VBW:1000KHz SWT:Auto Detector : Peak Project : 952409 Mode : 13 Setting : 17</p>	Left blank

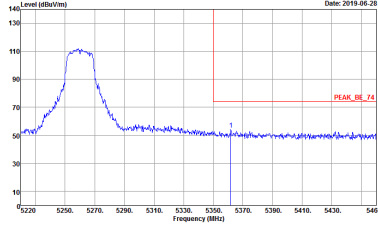
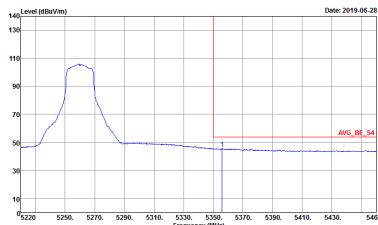

WIFI	Band 2 5250~5350MHz Band Edge @ 3m	
ANT	802.11ac VHT20 CH52 5260MHz - R	
1+2	Vertical	Fundamental
<p>Peak</p>	 <p>Site : 03CH2-HY Condition : PEAK_BE_74 3m HORN_9120D_1328 VERTICAL RBW:10000000Hz VBW:3000.0000Hz SWT:Auto Detector : Peak Project : 952409 Mode : 13 Setting : 17</p>	<p>Left blank</p>
<p>Avg.</p>	 <p>Site : 03CH2-HY Condition : AVG_BE_54 3m HORN_9120D_1328 VERTICAL RBW:10000000Hz VBW:1.0000Hz SWT:Auto Detector : Peak Project : 952409 Mode : 13 Setting : 17</p>	<p>Left blank</p>

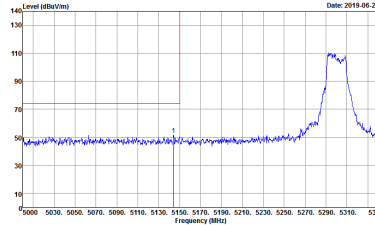
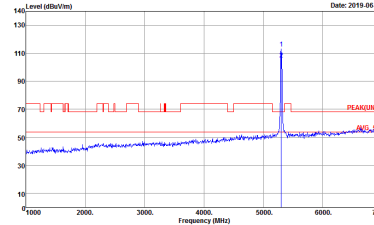
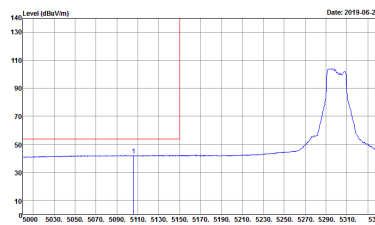

WIFI	Band 2 5250~5350MHz Band Edge @ 3m	
ANT	802.11ac VHT20 CH60 5300MHz - L	
1+2	Horizontal	Fundamental
<p>Peak</p>	 <p>Site : 03CH12-11Y Condition : PEAK_9C_74 3m HORN_9120D_1328 HORIZONTAL Detector : Peak Project : 952409 Mode : 14 Setting : 17</p>	 <p>Site : 03CH12-11Y Condition : PEAK(UNL) 3m HORN_9120D_1328 HORIZONTAL Detector : Peak Project : 952409 Mode : 14 Setting : 17</p>
<p>Avg.</p>	 <p>Site : 03CH12-11Y Condition : AVG_BE_14 3m HORN_9120D_1328 HORIZONTAL Detector : Peak Project : 952409 Mode : 14 Setting : 17</p>	<p>Left blank</p>

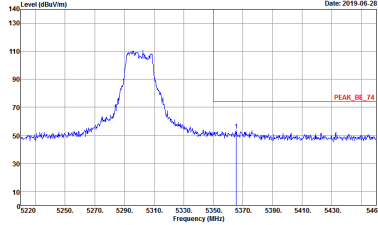
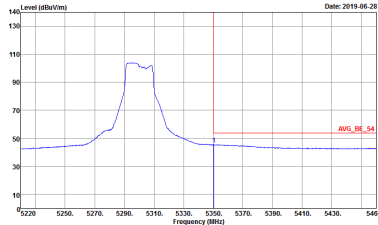

WIFI	Band 2 5250~5350MHz Band Edge @ 3m	
ANT	802.11ac VHT20 CH60 5300MHz - R	
1+2	Horizontal	Fundamental
<p>Peak</p>	 <p>Site : 03CH2-HY Condition : PEAK_BE_74 3m HORN_9120D_1328 HORIZONTAL Detector : Peak Project : 952409 Mode : 14 Setting : 17</p>	<p>Left blank</p>
<p>Avg.</p>	 <p>Site : 03CH2-HY Condition : AVG_BE_54 3m HORN_9120D_1328 HORIZONTAL Detector : Peak Project : 952409 Mode : 14 Setting : 17</p>	<p>Left blank</p>



WIFI	Band 2 5250~5350MHz Band Edge @ 3m	
ANT	802.11ac VHT20 CH60 5300MHz - L	
1+2	Vertical	Fundamental
Peak	<p>Site : 03CH2-11Y Condition : PEAK_BE_74 3m HORN_9120D_1328 VERTICAL RBW:3000.000KHz VBW:3000.000KHz SWT:Auto Detector : Peak Project : 952409 Mode : 14 Setting : 17</p>	<p>Site : 03CH2-11Y Condition : PEAK(UNL) 3m HORN_9120D_1328 VERTICAL RBW:3000.000KHz VBW:3000.000KHz SWT:Auto Detector : Peak Project : 952409 Mode : 14 Setting : 17</p>
Avg.	<p>Site : 03CH2-11Y Condition : AVG_BE_14 3m HORN_9120D_1328 VERTICAL RBW:3000.000KHz VBW:1000KHz SWT:Auto Detector : Peak Project : 952409 Mode : 14 Setting : 17</p>	Left blank

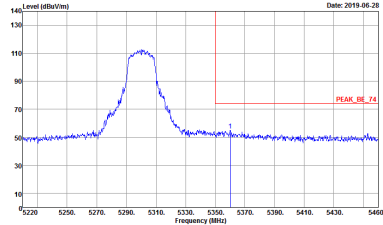
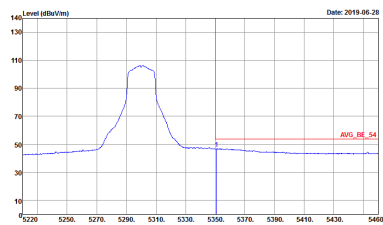

WIFI	Band 2 5250~5350MHz Band Edge @ 3m	
ANT	802.11ac VHT20 CH60 5300MHz - R	
1+2	Vertical	Fundamental
<p>Peak</p>	 <p>Site : 03CH2-HY Condition : PEAK_BE_74 3m HORN_9120D_1328 VERTICAL RBW:10000000Hz VBW:3000000Hz SWT:Auto Detector : Peak Project : 952409 Mode : 14 Setting : 17</p>	<p>Left blank</p>
<p>Avg.</p>	 <p>Site : 03CH2-HY Condition : AVG_BE_54 3m HORN_9120D_1328 VERTICAL RBW:10000000Hz VBW:10000Hz SWT:Auto Detector : Peak Project : 952409 Mode : 14 Setting : 17</p>	<p>Left blank</p>

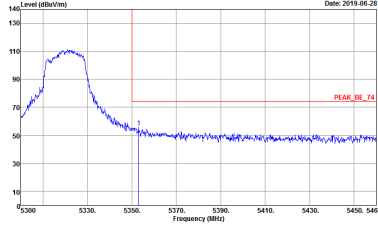
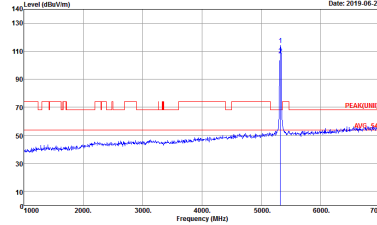
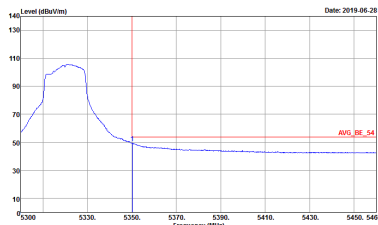

WIFI	Band 2 5250~5350MHz Band Edge @ 3m	
ANT	802.11ac VHT20 CH64 5320MHz	
1+2	Horizontal	Fundamental
<p>Peak</p>	 <p>Site : 03CH12-11Y Condition : PEAK_BE_74 3m HORN_9120D_1328 HORIZONTAL RBW:3000.000KHz VBW:3000.000KHz SWT:Auto Detector : Peak Project : 952409 Mode : 15 Setting : 17</p>	 <p>Site : 03CH12-11Y Condition : PEAK(UNL1) 3m HORN_9120D_1328 HORIZONTAL RBW:3000.000KHz VBW:3000.000KHz SWT:Auto Detector : Peak Project : 952409 Mode : 15 Setting : 17</p>
<p>Avg.</p>	 <p>Site : 03CH12-11Y Condition : AVG_BE_54 3m HORN_9120D_1328 HORIZONTAL RBW:3000.000KHz VBW:1000KHz SWT:Auto Detector : Peak Project : 952409 Mode : 15 Setting : 17</p>	<p>Left blank</p>



WIFI	Band 2 5250~5350MHz Band Edge @ 3m	
ANT	802.11ac VHT20 CH64 5320MHz	
1+2	Vertical	Fundamental
Peak	<p>Site : 03CH12-11Y Condition : PEAK_BE_74 3m HORN_9120D_1328 VERTICAL RBW:3000.000KHz VBW:3000.000KHz SWT:Auto Detector : Peak Project : 952409 Mode : 15 Setting : 17</p>	<p>Site : 03CH12-11Y Condition : PEAK(FUND) 3m HORN_9120D_1328 VERTICAL RBW:3000.000KHz VBW:3000.000KHz SWT:Auto Detector : Peak Project : 952409 Mode : 15 Setting : 17</p>
Avg.	<p>Site : 03CH12-11Y Condition : AVG_BE_54 3m HORN_9120D_1328 VERTICAL RBW:3000.000KHz VBW:1.000KHz SWT:Auto Detector : Peak Project : 952409 Mode : 15 Setting : 17</p>	Left blank



Band 2 5250~5350MHz
WIFI 802.11ac VHT40 (Band Edge @ 3m)

WIFI	Band 2 5250~5350MHz Band Edge @ 3m	
ANT	802.11ac VHT40 CH54 5270MHz - L	
1+2	Horizontal	Fundamental
Peak	<p>Site : 03CH12-HY Condition : PEAK_BE_74 3m HORN_9120D_1328 HORIZONTAL RBW:3000.000KHz VBW:3000.000KHz SWT:Auto Detector : Peak Project : 952409 Mode : 16 Setting : 13.5</p>	<p>Site : 03CH12-HY Condition : PEAK(UNIT1) 3m HORN_9120D_1328 HORIZONTAL RBW:3000.000KHz VBW:3000.000KHz SWT:Auto Detector : Peak Project : 952409 Mode : 16 Setting : 13.5</p>
Avg.	<p>Site : 03CH12-HY Condition : AVG_BE_54 3m HORN_9120D_1328 HORIZONTAL RBW:3000.000KHz VBW:3.000KHz SWT:Auto Detector : Peak Project : 952409 Mode : 16 Setting : 13.5</p>	Left blank

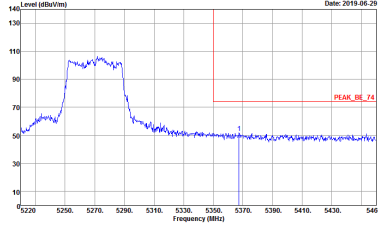
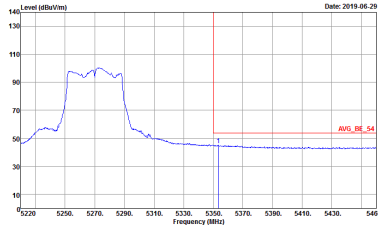

WIFI	Band 2 5250~5350MHz Band Edge @ 3m	
ANT	802.11ac VHT40 CH54 5270MHz - R	
1+2	Horizontal	Fundamental
<p>Peak</p>	 <p>Site : 03CH2-HY Condition : PEAK_BE_74 3m HORN_9120D_1328 HORIZONTAL RBW:10000000Hz VBW:3000000Hz SWT:Auto Detector : Peak Project : 952409 Mode : 16 Setting : 13.5</p>	<p>Left blank</p>
<p>Avg.</p>	 <p>Site : 03CH2-HY Condition : AVG_BE_54 3m HORN_9120D_1328 HORIZONTAL RBW:10000000Hz VBW:3000000Hz SWT:Auto Detector : Peak Project : 952409 Mode : 16 Setting : 13.5</p>	<p>Left blank</p>

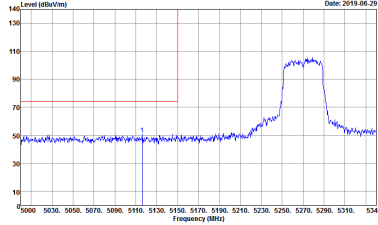
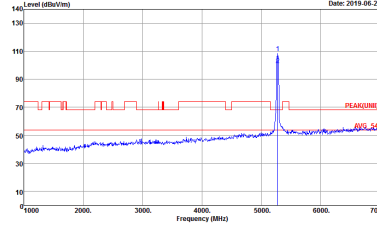
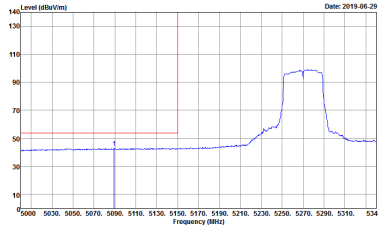

WIFI	Band 2 5250~5350MHz Band Edge @ 3m	
ANT	802.11ac VHT40 CH54 5270MHz - L	
1+2	Vertical	Fundamental
Peak	 <p>Site : 03CH12-11Y Condition : PEAK_9C_74 3m HORN_9120D_1328 VERTICAL RBW:3000.000kHz VBW:3000.000kHz SWT:Auto Detector : Peak Project : 952409 Mode : 16 Setting : 13.5</p>	 <p>Site : 03CH12-11Y Condition : PEAK(UNL) 3m HORN_9120D_1328 VERTICAL RBW:3000.000kHz VBW:3000.000kHz SWT:Auto Detector : Peak Project : 952409 Mode : 16 Setting : 13.5</p>
Avg.	 <p>Site : 03CH12-11Y Condition : AVG_BE_14 3m HORN_9120D_1328 VERTICAL RBW:3000.000kHz VBW:3000.000kHz SWT:Auto Detector : Peak Project : 952409 Mode : 16 Setting : 13.5</p>	Left blank



WIFI	Band 2 5250~5350MHz Band Edge @ 3m	
ANT	802.11ac VHT40 CH54 5270MHz - R	
1+2	Vertical	Fundamental
Peak	<p>Site : 03CH2-HY Condition : PEAK_BE_74 3m HORN_9120D_1328 VERTICAL RBW:10000000Hz VBW:3000000Hz SWT:Auto Detector : Peak Project : 952409 Mode : 16 Setting : 13.5</p>	Left blank
Avg.	<p>Site : 03CH2-HY Condition : AVG_BE_54 3m HORN_9120D_1328 VERTICAL RBW:10000000Hz VBW:3000000Hz SWT:Auto Detector : Peak Project : 952409 Mode : 16 Setting : 13.5</p>	Left blank

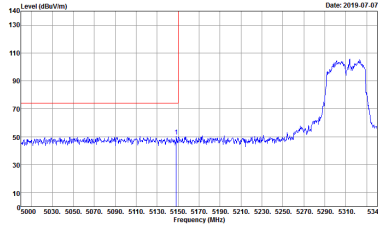
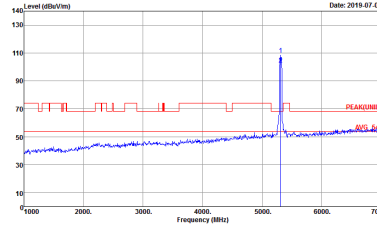
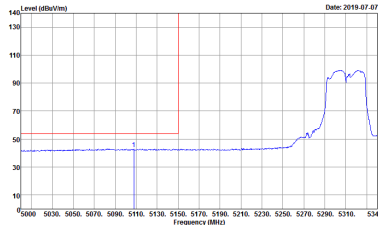

WIFI	Band 2 5250~5350MHz Band Edge @ 3m	
ANT	802.11ac VHT40 CH62 5310MHz - L	
1+2	Horizontal	Fundamental
<p>Peak</p>	 <p>Date: 2019-07-07</p> <p>Site : 03CH12-HY Condition : PEAK_BE_74 3m HORN_91200_1328 HORIZONTAL RBW:3000.000kHz VBW:3000.000kHz SWT:Auto Detector : Peak Project : 952409 Mode : 17 Setting : 13.5</p>	 <p>Date: 2019-07-07</p> <p>Site : 03CH12-HY Condition : PEAK(FUNDE) 3m HORN_91200_1328 HORIZONTAL RBW:3000.000kHz VBW:3000.000kHz SWT:Auto Detector : Peak Project : 952409 Mode : 17 Setting : 13.5</p>
<p>Avg.</p>	 <p>Date: 2019-07-07</p> <p>Site : 03CH12-HY Condition : AVG_BE_54 3m HORN_91200_1328 HORIZONTAL RBW:3000.000kHz VBW:3000.000kHz SWT:Auto Detector : Peak Project : 952409 Mode : 17 Setting : 13.5</p>	<p>Left blank</p>



WIFI	Band 2 5250~5350MHz Band Edge @ 3m	
ANT	802.11ac VHT40 CH62 5310MHz - R	
1+2	Horizontal	Fundamental
Peak	<p>Site : 03CH12-HY Condition : PEAK_BE_74 3m HORN_91200_1328 HORIZONTAL Detector : Peak Project : 952409 Mode : 17 Setting : 13.5</p>	Left blank
Avg.	<p>Site : 03CH12-HY Condition : AVG_BE_54 3m HORN_91200_1328 HORIZONTAL Detector : Peak Project : 952409 Mode : 17 Setting : 13.5</p>	Left blank

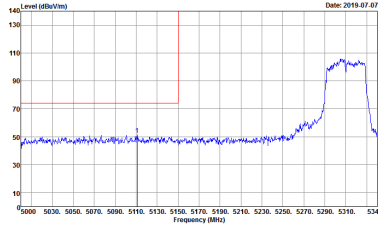
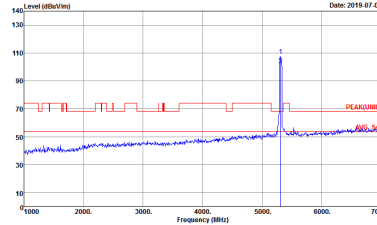
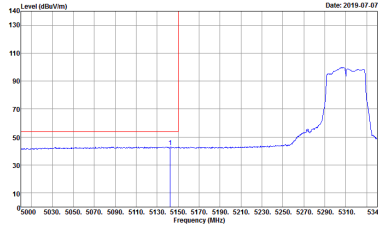

WIFI	Band 2 5250~5350MHz Band Edge @ 3m	
ANT	802.11ac VHT40 CH62 5310MHz - L	
1+2	Vertical	Fundamental
<p>Peak</p>	 <p>Date: 2019-07-07</p> <p>Site : 03CH12-HY Condition : PEAK_BE_74 3m HORN_91200_1328 VERTICAL Detector : Peak Project : 952409 Mode : 17 Setting : 13.5</p>	 <p>Date: 2019-07-07</p> <p>Site : 03CH12-HY Condition : PEAK(FUNDE) 3m HORN_91200_1328 VERTICAL Detector : Peak Project : 952409 Mode : 17 Setting : 13.5</p>
<p>Avg.</p>	 <p>Date: 2019-07-07</p> <p>Site : 03CH12-HY Condition : AVG_BE_54 3m HORN_91200_1328 VERTICAL Detector : Peak Project : 952409 Mode : 17 Setting : 13.5</p>	<p>Left blank</p>

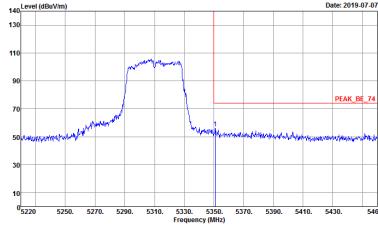
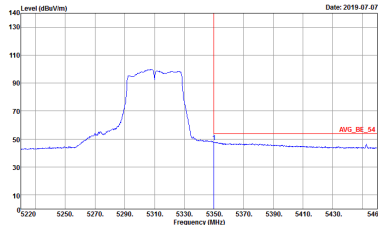

WIFI	Band 2 5250~5350MHz Band Edge @ 3m	
ANT	802.11ac VHT40 CH62 5310MHz - R	
1+2	Vertical	Fundamental
<p>Peak</p>	 <p>Date: 2019-07-07</p> <p>Site : 03CH12-HY Condition : PEAK_BE_74 3m HORN_91200_1328 VERTICAL Detector : Peak Project : 952409 Mode : 17 Setting : 13.5</p>	<p>Left blank</p>
<p>Avg.</p>	 <p>Date: 2019-07-07</p> <p>Site : 03CH12-HY Condition : AVG_BE_54 3m HORN_91200_1328 VERTICAL Detector : Peak Project : 952409 Mode : 17 Setting : 13.5</p>	<p>Left blank</p>



Band 2 5250~5350MHz
WIFI 802.11ac VHT80 (Band Edge @ 3m)

WIFI	Band 2 5250~5350MHz Band Edge @ 3m	
ANT	802.11ac VHT80 CH58 5290MHz - L	
1+2	Horizontal	Fundamental
Peak	<p>Site : 03CH12-HY Condition : PEAK_BE_74 3m HORN_9120D_1328 HORIZONTAL RBW:1000.000KHz VBW:3000.000KHz SWT:Auto Detector : Peak Project : 952409 Mode : 1B Setting : 10.5</p>	<p>Site : 03CH12-HY Condition : PEAK(LINE) 3m HORN_9120D_1328 HORIZONTAL RBW:1000.000KHz VBW:3000.000KHz SWT:Auto Detector : Peak Project : 952409 Mode : 1B Setting : 10.5</p>
Avg.	<p>Site : 03CH12-HY Condition : AVG_BE_54 3m HORN_9120D_1328 HORIZONTAL RBW:1000.000KHz VBW:3.000KHz SWT:Auto Detector : Peak Project : 952409 Mode : 1B Setting : 10.5</p>	Left blank

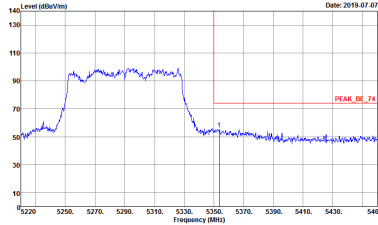
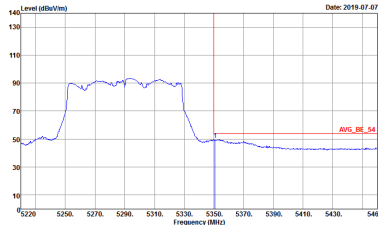

WIFI	Band 2 5250~5350MHz Band Edge @ 3m	
ANT	802.11ac VHT80 CH58 5290MHz - R	
1+2	Horizontal	Fundamental
<p>Peak</p>	 <p>Date: 2019-07-07</p> <p>Site : 03CH12-HY Condition : PEAK_BE_74 3m HORN_91200_1328 HORIZONTAL Detector : Peak Project : 952409 Mode : 1B Setting : 10.5</p>	<p>Left blank</p>
<p>Avg.</p>	 <p>Date: 2019-07-07</p> <p>Site : 03CH12-HY Condition : AVG_BE_54 3m HORN_91200_1328 HORIZONTAL Detector : Peak Project : 952409 Mode : 1B Setting : 10.5</p>	<p>Left blank</p>