



FCC RADIO TEST REPORT

FCC ID : 2AG0Z-P4LK
Equipment : Media Receiver
Brand Name : facebook
Model Name : WD50JM
Applicant : Facebook Technologies LLC
1 Hacker Way, Menlo Park, CA 94025, USA
Standard : FCC Part 15 Subpart C §15.247

The product was received on May 24, 2019 and testing was started from Jun. 10, 2019 and completed on Jul. 09, 2019. We, SPORTON INTERNATIONAL INC., EMC & Wireless Communications Laboratory, would like to declare that the tested sample has been evaluated in accordance with the test procedures and has been in compliance with the applicable technical standards.

The report must not be used by the client to claim product certification, approval, or endorsement by TAF or any agency of government.

The test results in this report apply exclusively to the tested model / sample. Without written approval of SPORTON INTERNATIONAL INC. EMC & Wireless Communications Laboratory, the test report shall not be reproduced except in full.

Approved by: Jones Tsai

SPORTON INTERNATIONAL INC. EMC & Wireless Communications Laboratory
No. 52, Huaya 1st Rd., Guishan Dist., Taoyuan City, Taiwan (R.O.C.)



Table of Contents

1	General Description	5
1.1	Product Feature of Equipment Under Test.....	5
1.2	Modification of EUT	5
1.3	Testing Location	5
1.4	Applicable Standards.....	6
2	Test Configuration of Equipment Under Test	7
2.1	Carrier Frequency and Channel	7
2.2	Test Mode.....	7
2.3	Connection Diagram of Test System.....	8
2.4	Support Unit used in test configuration and system	9
2.5	EUT Operation Test Setup	9
2.6	Measurement Results Explanation Example.....	10
3	Test Result	11
3.1	6dB and 99% Bandwidth Measurement	11
3.2	Output Power Measurement.....	13
3.3	Power Spectral Density Measurement	14
3.4	Conducted Band Edges and Spurious Emission Measurement	16
3.5	Radiated Band Edges and Spurious Emission Measurement	35
3.6	AC Conducted Emission Measurement.....	39
3.7	Antenna Requirements.....	41
4	List of Measuring Equipment.....	42
5	Uncertainty of Evaluation	44
	Appendix A. Conducted Test Results	
	Appendix B. AC Conducted Emission Test Result	
	Appendix C. Radiated Spurious Emission	
	Appendix D. Radiated Spurious Emission Plots	
	Appendix E. Duty Cycle Plots	
	Appendix F. Setup Photographs	



History of this test report

Report No.	Version	Description	Issued Date
FR952409C	01	Initial issue of report	Jul. 12, 2019
FR952409C	02	Revise the connection diagram of test system in section 2.3	Jul. 29, 2019



Summary of Test Result

Report Clause	Ref Std. Clause	Test Items	Result (PASS/FAIL)	Remark
3.1	15.247(a)(2)	6dB Bandwidth	Pass	-
3.1	2.1049	99% Occupied Bandwidth	Reporting only	-
3.2	15.247(b)	Power Output Measurement	Pass	-
3.3	15.247(e)	Power Spectral Density	Pass	-
3.4	15.247(d)	Conducted Band Edges	Pass	-
		Conducted Spurious Emission	Pass	-
0	15.247(d)	Radiated Band Edges and Radiated Spurious Emission	Pass	Under limit 1.07 dB at 2483.520 MHz
3.6	15.207	AC Conducted Emission	Pass	Under limit 12.32 dB at 0.164 MHz
3.7	15.203 & 15.247(b)	Antenna Requirement	Pass	-

Declaration of Conformity:

The test results with all measurement uncertainty excluded are presented in accordance with the regulation limits or requirements declared by manufacturers.

Comments and Explanations:

The declared of product specification for EUT presented in the report are provided by the manufacturer, and the manufacturer takes all the responsibilities for the accuracy of product specification.

Reviewed by: Wii Chang

Report Producer: Ann Lee



1 General Description

1.1 Product Feature of Equipment Under Test

Bluetooth, Wi-Fi 2.4GHz 802.11b/g/n/ac and Wi-Fi 5GHz 802.11a/n/ac

Product specification subjective to this standard	
Antenna Type	WLAN: <Ant.1> FPC Antenna <Ant.2> FPC Antenna Bluetooth: FPC Antenna

1.2 Modification of EUT

No modifications are made to the EUT during all test items.

1.3 Testing Location

Test Site	SPORTON INTERNATIONAL INC. EMC & Wireless Communications Laboratory	
Test Site Location	No.52, Huaya 1st Rd., Guishan Dist., Taoyuan City, Taiwan (R.O.C.) TEL: +886-3-327-3456 FAX: +886-3-328-4978	
Test Site No.	Sporton Site No.	
	TH05-HY	CO05-HY

Note: The test site complies with ANSI C63.4 2014 requirement.

Test Site	SPORTON INTERNATIONAL INC. EMC & Wireless Communications Laboratory	
Test Site Location	No.58, Aly. 75, Ln. 564, Wenhua 3rd, Rd., Guishan Dist., Taoyuan City, Taiwan (R.O.C.) TEL: +886-3-327-0868 FAX: +886-3-327-0855	
Test Site No.	Sporton Site No.	
	03CH12-HY	

Note: The test site complies with ANSI C63.4 2014 requirement.

FCC designation No.: TW1190 and TW0007



1.4 Applicable Standards

According to the specifications of the manufacturer, the EUT must comply with the requirements of the following standards:

- ♦ FCC Part 15 Subpart C §15.247
- ♦ FCC KDB Publication No. 558074 D01 DTS Meas. Guidance v05r02
- ♦ FCC KDB 414788 D01 Radiated Test Site v01r01.
- ♦ FCC KDB 662911 D01 Multiple Transmitter Output v02r01.
- ♦ ANSI C63.10-2013

Remark:

1. All test items were verified and recorded according to the standards and without any deviation during the test.
2. This EUT has also been tested and complied with the requirements of FCC Part 15, Subpart B, recorded in a separate test report.



2 Test Configuration of Equipment Under Test

- a. The EUT has been associated with peripherals and configuration operated in a manner tended to maximize its emission characteristics in a typical application. Frequency range investigated: conduction emission (150 kHz to 30 MHz), radiation emission (9 kHz to the 10th harmonic of the highest fundamental frequency or to 40 GHz, whichever is lower). For radiated measurement, pre-scanned in three orthogonal panels, X, Y, Z. The worst cases (Y plane) were recorded in this report, and the worst mode of radiated spurious emissions is Bluetooth 1Mbps mode, and recorded in this report.
- b. AC power line Conducted Emission was tested under maximum output power.

2.1 Carrier Frequency and Channel

Frequency Band	Channel	Freq. (MHz)	Channel	Freq. (MHz)
2400-2483.5 MHz	1	2412	7	2442
	2	2417	8	2447
	3	2422	9	2452
	4	2427	10	2457
	5	2432	11	2462
	6	2437		

2.2 Test Mode

Final test modes are considering the modulation and worse data rates as below table.

MIMO Antenna

Modulation	Data Rate
802.11b	1 Mbps
802.11g	6 Mbps
802.11n HT20 (Covered by VHT20)	MCS0
802.11ac VHT20	MCS0

Test Cases	
AC Conducted Emission	Mode 1 :Bluetooth Idle + WLAN (2.4GHz) Link + Thermal Test + USB-C to RJ45 Cable (Load) + AC Adapter

2.3 Connection Diagram of Test System

<WLAN Tx Mode>

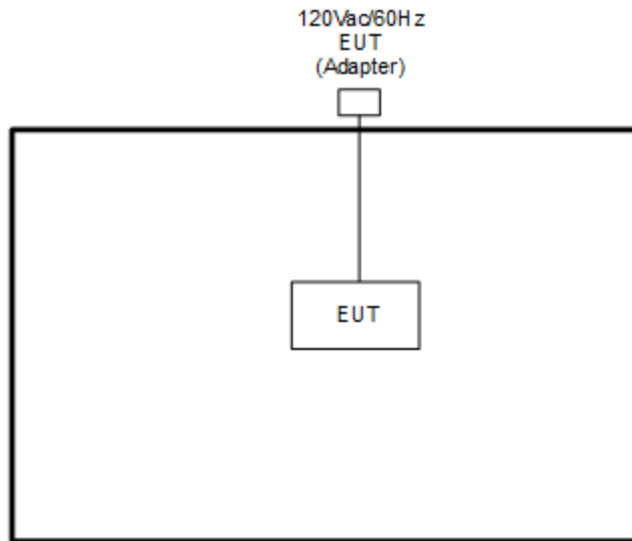

<AC Conducted Emission Mode>

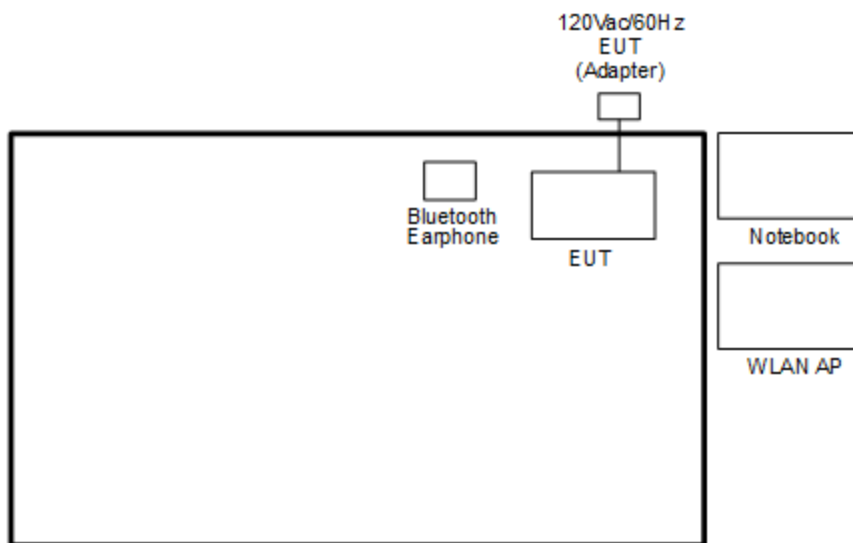



2.4 Support Unit used in test configuration and system

Item	Equipment	Trade Name	Model Name	FCC ID	Data Cable	Power Cord
1.	Bluetooth Earphone	Sony Ericsson	MW600	PY7DDA-2029	N/A	N/A
2.	WLAN AP	ASUS	RT-AC66U	MSQ-RTAC66U	N/A	Unshielded, 1.8 m
3.	Notebook	DELL	Latitude E6320	FCC DoC/ Contains FCC ID: QDS-BRCM1054	N/A	AC I/P: Unshielded, 1.2 m DC O/P: Shielded, 1.8 m

2.5 EUT Operation Test Setup

The RF test items, utility “QRCT” was installed in Notebook which was programmed in order to make the EUT get into the engineering modes to provide channel selection, power level, data rate and the application type and for continuous transmitting signals.

Remark:

QRCT Version 4.0.00067 for Radiated Spurious Emission

QRCT Version 4.0.00108 for Conducted



2.6 Measurement Results Explanation Example

For all conducted test items:

The offset level is set in the spectrum analyzer to compensate the RF cable loss and attenuator factor between EUT conducted output port and spectrum analyzer. With the offset compensation, the spectrum analyzer reading level is exactly the EUT RF output level.

Example:

The spectrum analyzer offset is derived from RF cable loss and attenuator factor.

Offset = RF cable loss + attenuator factor.

Following shows an offset computation example with cable loss 4.8 dB and 20dB attenuator.

$$\begin{aligned} \text{Offset(dB)} &= \text{RF cable loss(dB)} + \text{attenuator factor(dB)}. \\ &= 4.8 + 20 = 24.80 \text{ (dB)} \end{aligned}$$

3 Test Result

3.1 6dB and 99% Bandwidth Measurement

3.1.1 Limit of 6dB and 99% Bandwidth

The minimum 6 dB bandwidth shall be at least 500 kHz.

3.1.2 Measuring Instruments

See list of measuring equipment of this test report.

3.1.3 Test Procedures

1. The testing follows the ANSI C63.10 Section 6.9.3 (OBW) and 11.8.1 (6dB BW).
2. The RF output of EUT was connected to the spectrum analyzer by RF cable and attenuator. The path loss was compensated to the results for each measurement.
3. Set to the maximum power setting and enable the EUT transmit continuously.
4. Make the measurement with the spectrum analyzer's resolution bandwidth (RBW) = 100 kHz. Set the Video bandwidth (VBW) = 300 kHz. In order to make an accurate measurement. The 6 dB bandwidth must be greater than 500 kHz.
5. For 99% Bandwidth Measurement, the spectrum analyzer's resolution bandwidth (RBW) is set 1-5% of the emission bandwidth and set the Video bandwidth (VBW) $\geq 3 * RBW$.
6. Measure and record the results in the test report.

3.1.4 Test Setup





3.1.5 Test Result of 6dB and 99% Occupied Bandwidth

Please refer to Appendix A.

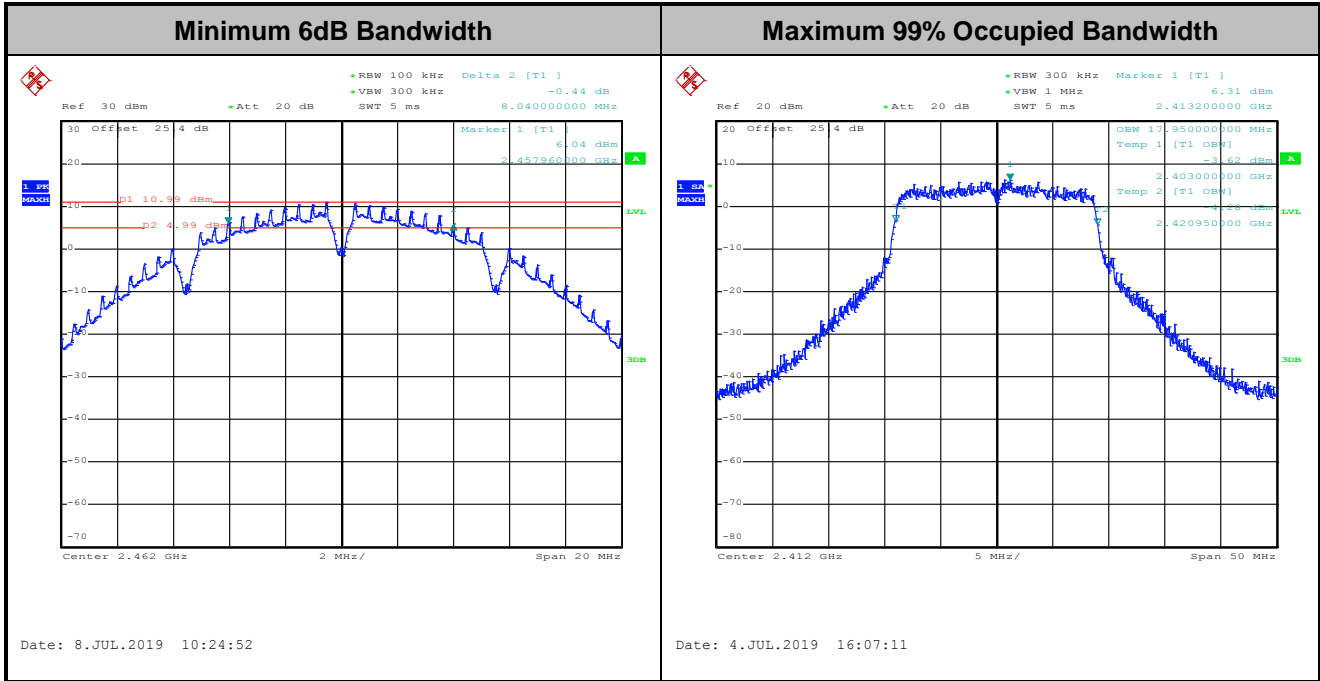

Note: The occupied channel bandwidth is maintained within the band of operation for all of the modulations.

3.2 Output Power Measurement

3.2.1 Limit of Output Power

For systems using digital modulation in the 2400-2483.5MHz, the limit for peak output power is 30dBm. If transmitting antenna with directional gain greater than 6dBi is used, the peak output power from the intentional radiator shall be reduced below the above stated value by the amount in dB that the directional gain of the antenna exceeds 6 dBi. In case of point-to-point operation, the limit has to be reduced by 1dB for every 3dB that the directional gain of the antenna exceeds 6dBi.

3.2.2 Measuring Instruments

See list of measuring equipment of this test report.

3.2.3 Test Procedures

1. For Peak Power, the testing follows ANSI C63.10 Section 11.9.1.3 PKPM1
2. For Average Power, the testing follows ANSI C63.10 Section 11.9.2.3.2 Method AVGPM-G
3. The RF output of EUT was connected to the power meter by RF cable and attenuator. The path loss was compensated to the results for each measurement.
4. Set to the maximum power setting and enable the EUT transmit continuously.
5. Measure the conducted output power and record the results in the test report.
6. For MIMO mode, calculation method follows FCC KDB 662911 D01 Multiple Transmitter Output v02r01.

3.2.4 Test Setup

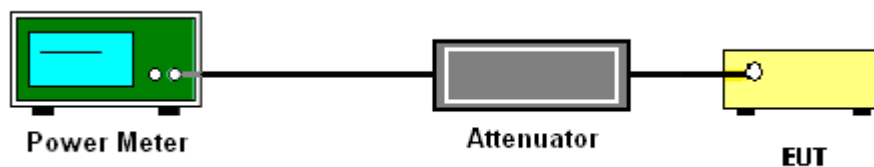

3.2.5 Test Result of Average Output Power

Please refer to Appendix A.



3.3 Power Spectral Density Measurement

3.3.1 Limit of Power Spectral Density

The peak power spectral density shall not be greater than 8dBm in any 3kHz band at any time interval of continuous transmission.

3.3.2 Measuring Instruments

See list of measuring equipment of this test report.

3.3.3 Test Procedures

1. The testing follows the ANSI C63.10 Section 11.10.2 Method PKPSD.
2. The RF output of EUT was connected to the spectrum analyzer by RF cable and attenuator. The path loss was compensated to the results for each measurement.
3. Set to the maximum power setting and enable the EUT transmit continuously.
4. Make the measurement with the spectrum analyzer's resolution bandwidth (RBW) = 3 kHz. Video bandwidth VBW = 10 kHz In order to make an accurate measurement, set the span to 1.5 times DTS Channel Bandwidth. (6dB BW)
5. Detector = peak, Sweep time = auto couple, Trace mode = max hold, Allow trace to fully stabilize. Use the peak marker function to determine the maximum power level.
6. Measure and record the results in the test report.
7. For MIMO mode, calculation method follows FCC KDB 662911 D01 Multiple Transmitter Output v02r01.

If measurements performed using method (2) plus $10 \log(N)$ exceeds the emission limit, the test should choose method (1) before declaring that the device fails the emission limit.

Method (1): Measure and sum the spectra across the outputs.

The total final Power Spectral Density is from a device with 2 transmitter outputs. The spectrum measurements of the individual outputs are all performed with the same span and number of points, the spectrum value in the first spectral bin of output 1 is summed with that in the first spectral bin of output 2 to obtain the value for the first frequency bin of the summed spectrum.

Method (2): Measure and add $10 \log(N)$ dB, where N is the number of outputs. (N=2)

3.3.4 Test Setup

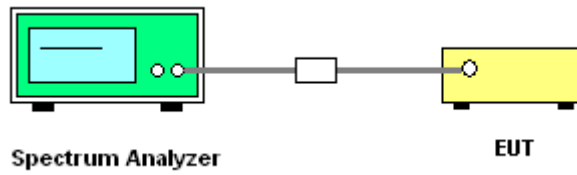

3.3.5 Test Result of Power Spectral Density

Please refer to Appendix A.

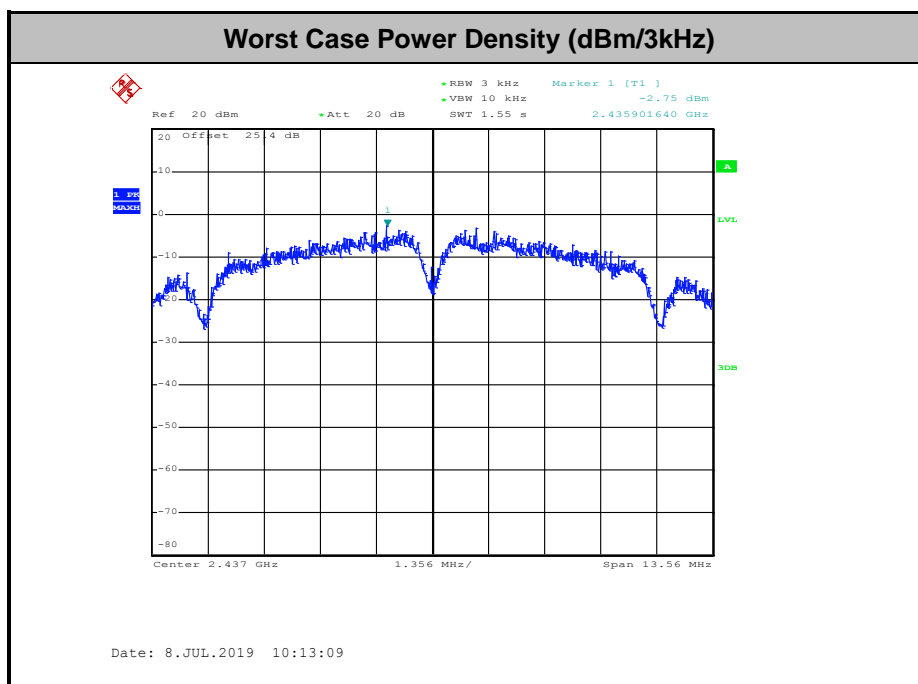

3.4 Conducted Band Edges and Spurious Emission Measurement

3.4.1 Limit of Conducted Band Edges and Spurious Emission Measurement

In any 100 kHz bandwidth outside of the authorized frequency band, the emissions which fall in the non-restricted bands shall be attenuated at least 20 dB / 30dB relative to the maximum PSD level in 100 kHz by RF conducted measurement.

3.4.2 Measuring Instruments

See list of measuring equipment of this test report.

3.4.3 Test Procedures

1. The testing follows the ANSI C63.10 Section 11.11.3 Emission level measurement.
2. The RF output of EUT was connected to the spectrum analyzer by RF cable and attenuator. The path loss was compensated to the results for each measurement.
3. Set to the maximum power setting and enable the EUT transmit continuously.
4. Set RBW = 100 kHz, VBW=300 kHz, Peak Detector. Unwanted Emissions measured in any 100 kHz bandwidth outside of the authorized frequency band shall be attenuated by at least 20 dB relative to the maximum in-band peak PSD level in 100 kHz when maximum peak conducted output power procedure is used. If the transmitter complies with the conducted power limits based on the use of RMS averaging over a time interval, the attenuation required under this paragraph shall be 30 dB instead of 20 dB per 15.247(d).
5. Measure and record the results in the test report.
6. The RF fundamental frequency should be excluded against the limit line in the operating frequency band.

3.4.4 Test Setup

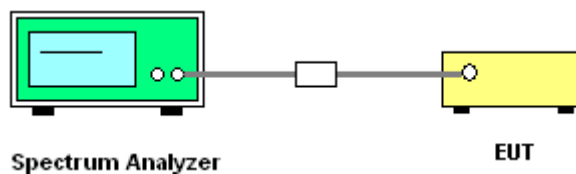



3.4.5 Test Result of Conducted Band Edges and Spurious Emission

Test Engineer : Richard Qiu	Temperature :	21~25°C
	Relative Humidity :	51~54%

Number of TX = 2, Ant. 1 (Measured)

Test Mode :	802.11b	Test Channel :	01
-------------	---------	----------------	----

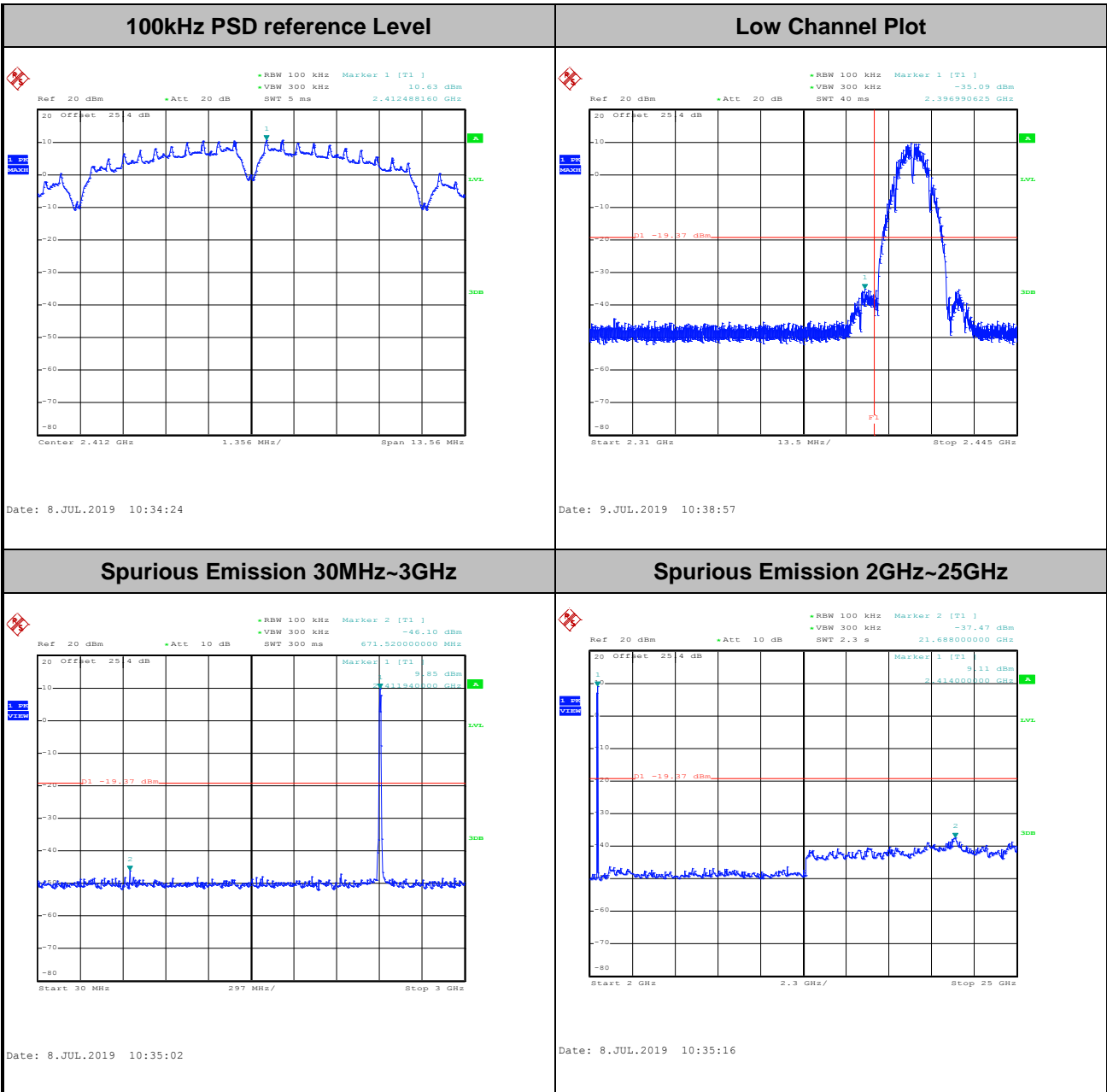



Test Mode :	802.11b	Test Channel :	06
-------------	---------	----------------	----

100kHz PSD reference Level	Mid Channel Plot
-----------------------------------	-------------------------

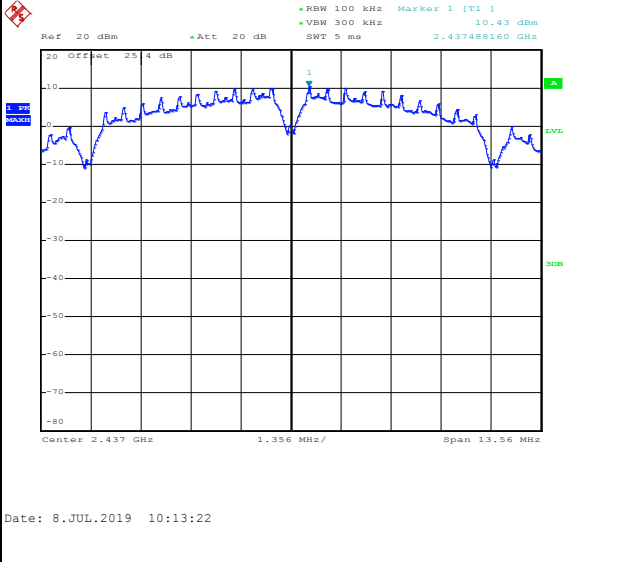

Spurious Emission 30MHz~3GHz	Spurious Emission 2GHz~25GHz
-------------------------------------	-------------------------------------

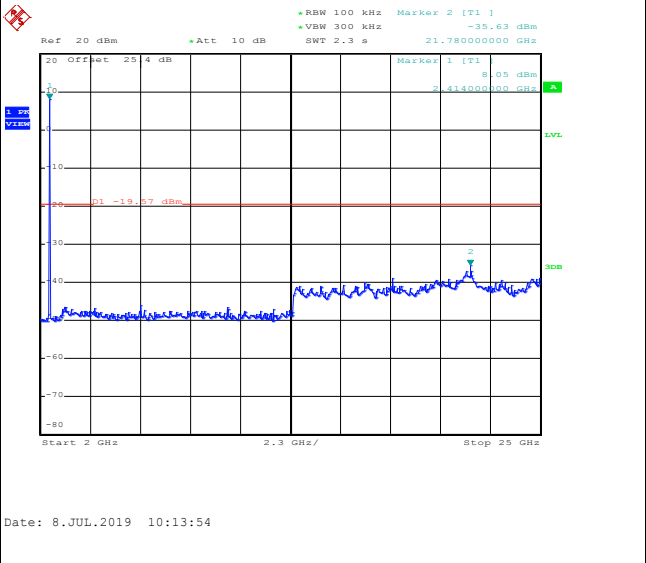
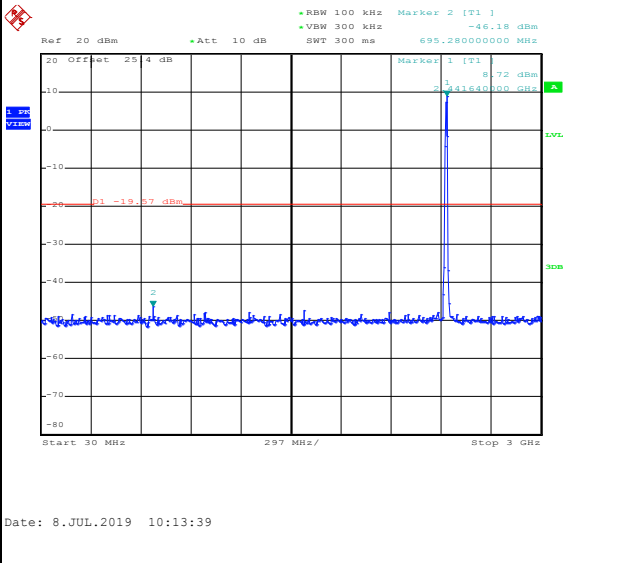



Test Mode :	802.11b	Test Channel :	11
-------------	---------	----------------	----

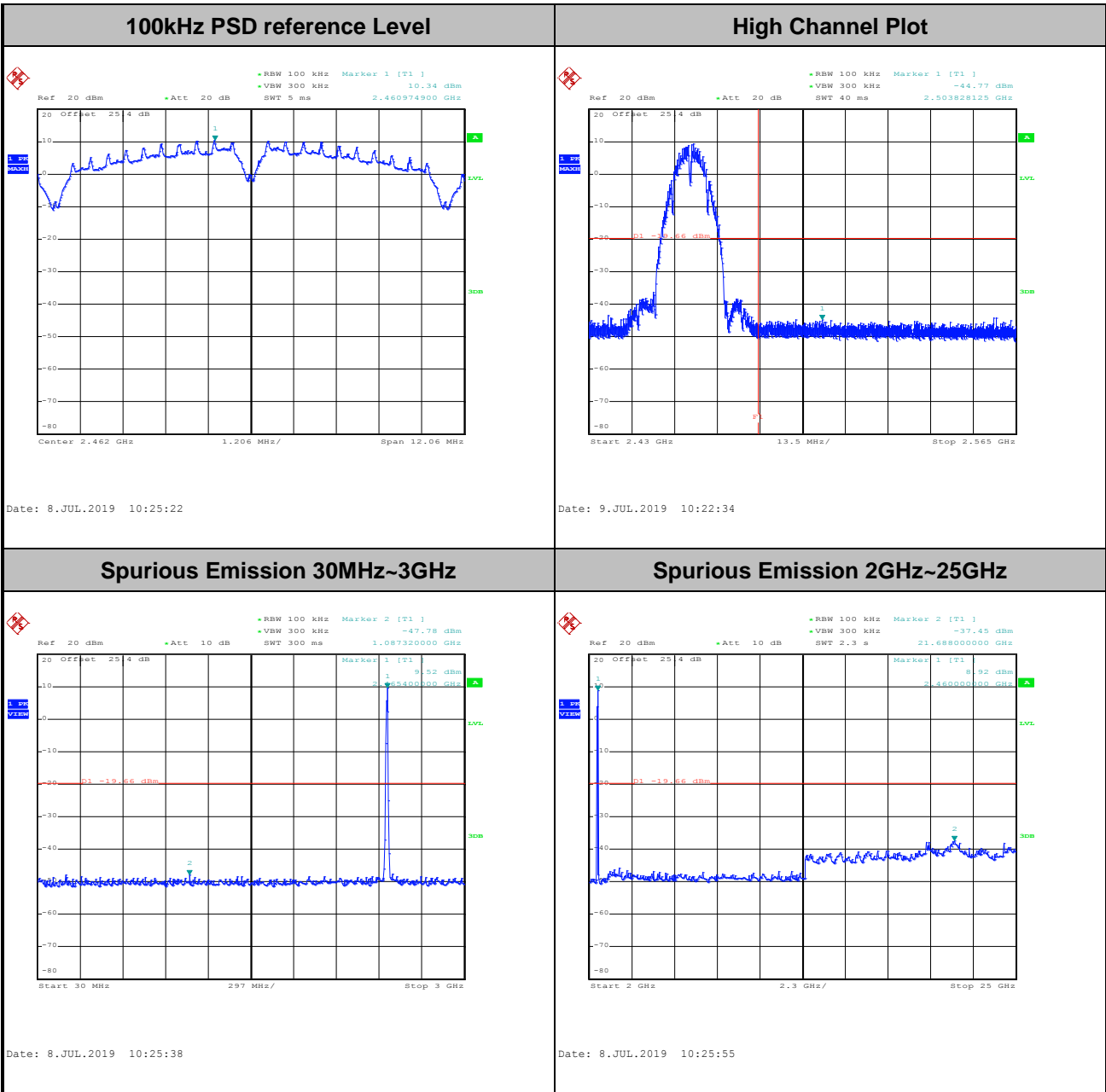



Test Mode :	802.11g	Test Channel :	01
-------------	---------	----------------	----

100kHz PSD reference Level	Low Channel Plot
-----------------------------------	-------------------------

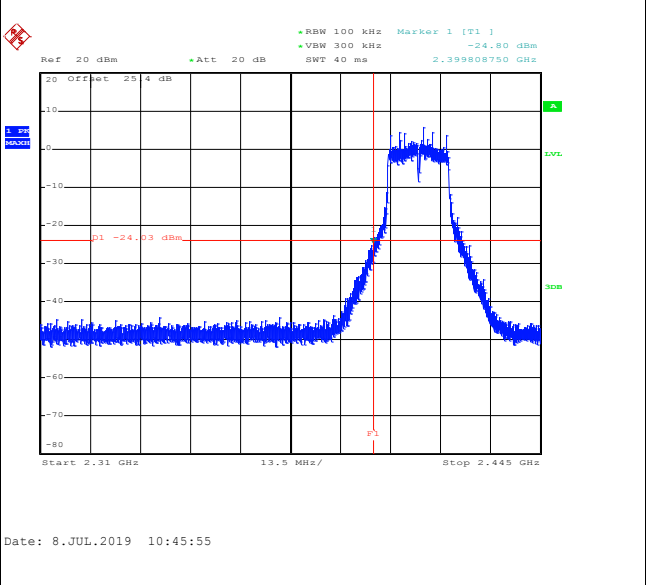
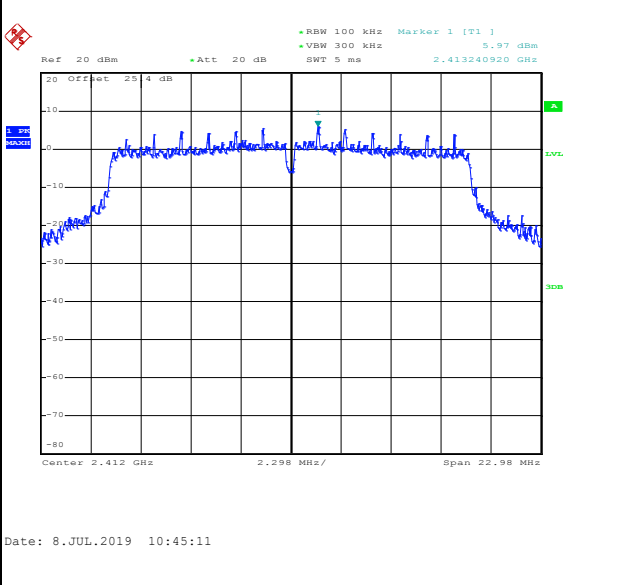

Spurious Emission 30MHz~3GHz	Spurious Emission 2GHz~25GHz
-------------------------------------	-------------------------------------

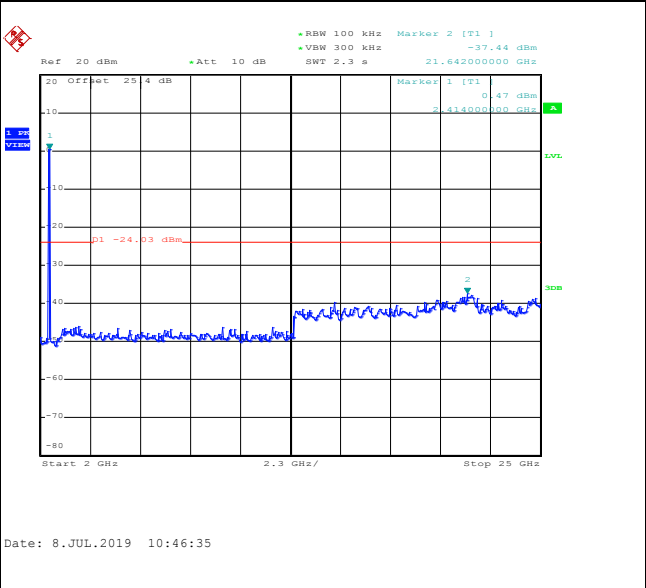
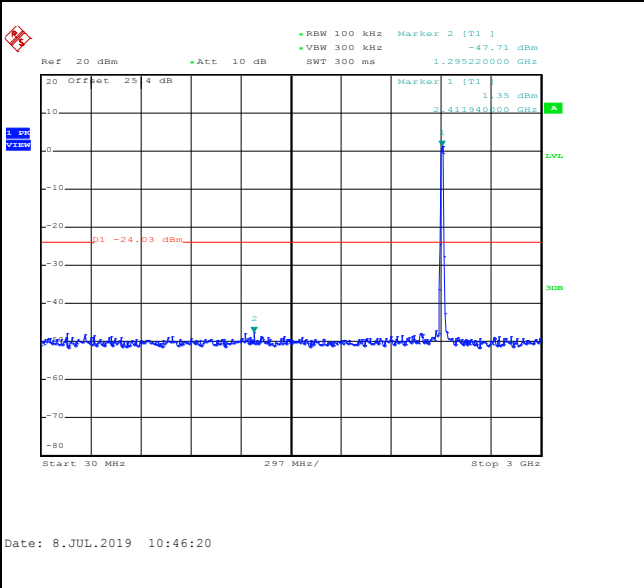



Test Mode :	802.11g	Test Channel :	06
-------------	---------	----------------	----

100kHz PSD reference Level	Mid Channel Plot
-----------------------------------	-------------------------

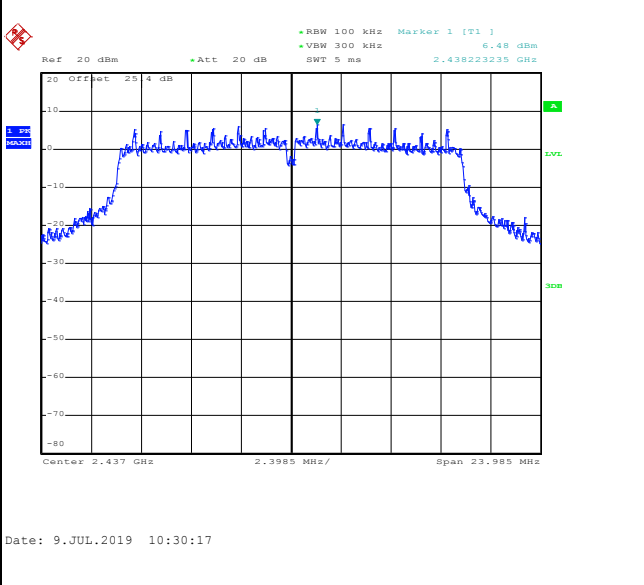

Spurious Emission 30MHz~3GHz	Spurious Emission 2GHz~25GHz
-------------------------------------	-------------------------------------

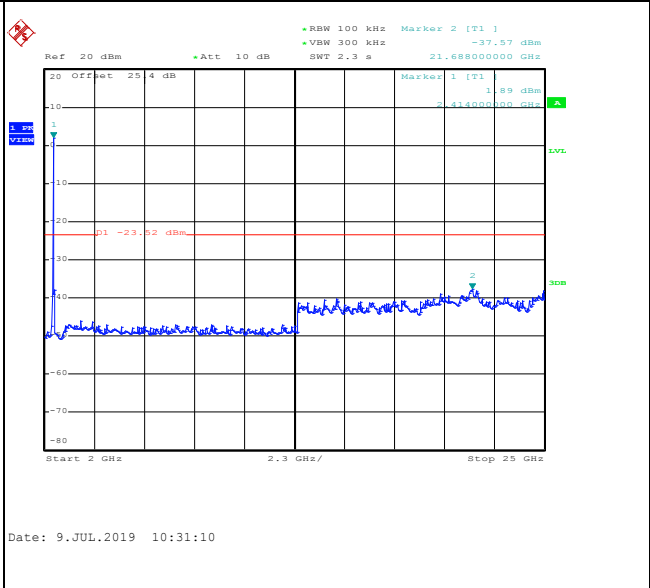
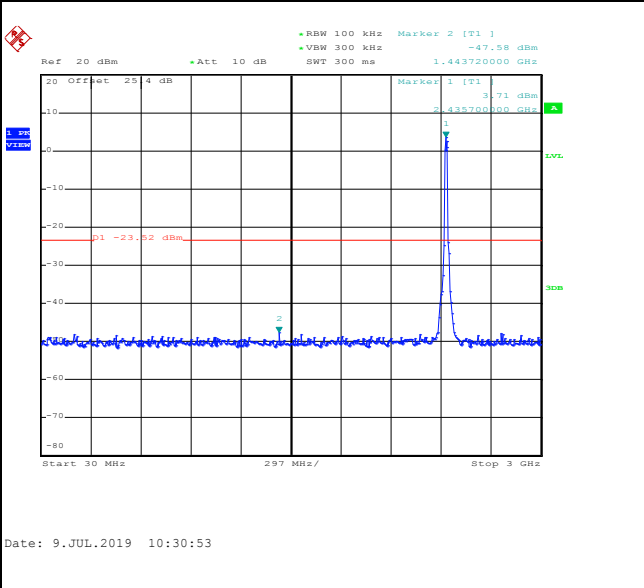



Test Mode :	802.11g	Test Channel :	11
-------------	---------	----------------	----

100kHz PSD reference Level	High Channel Plot
-----------------------------------	--------------------------

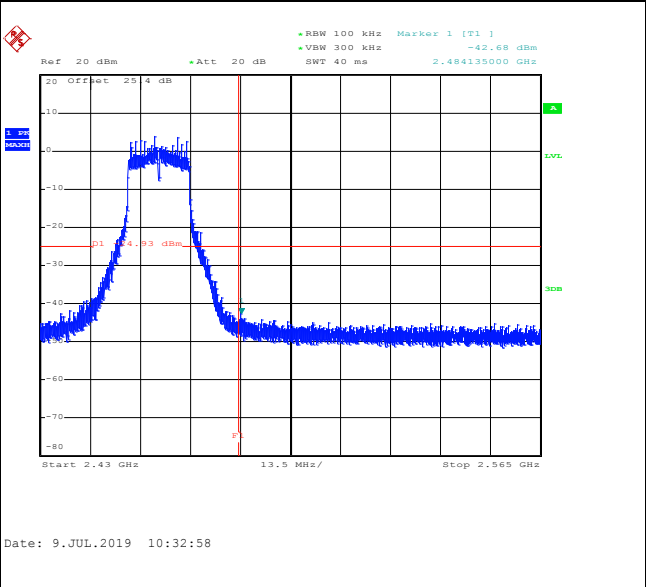
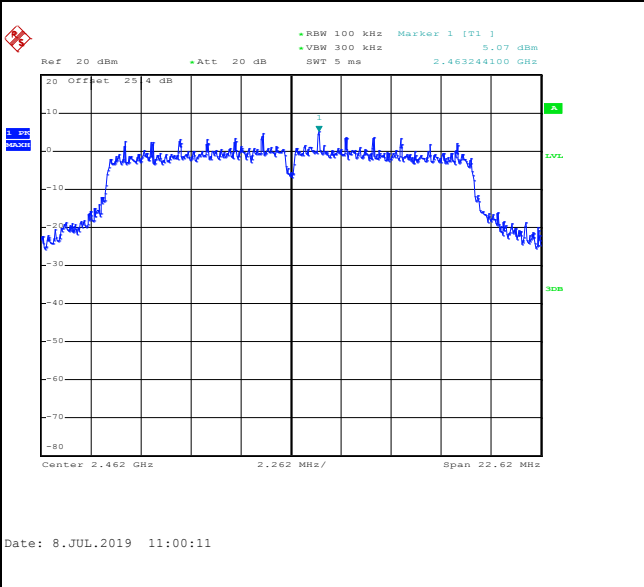

Spurious Emission 30MHz~3GHz	Spurious Emission 2GHz~25GHz
-------------------------------------	-------------------------------------

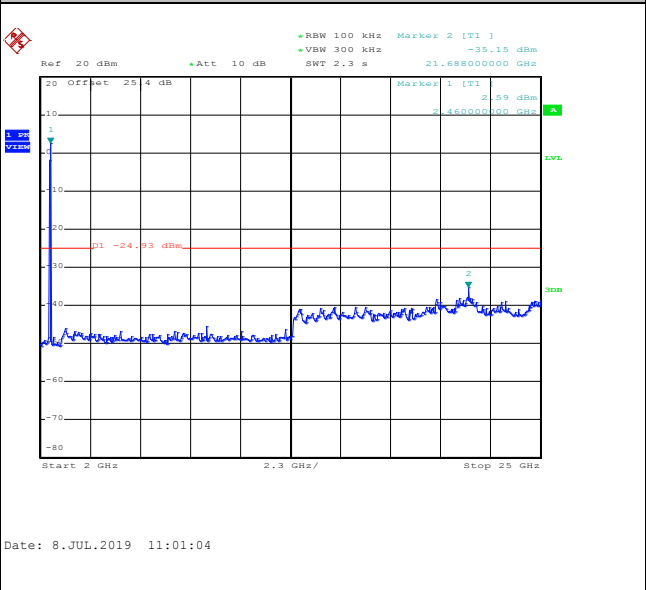
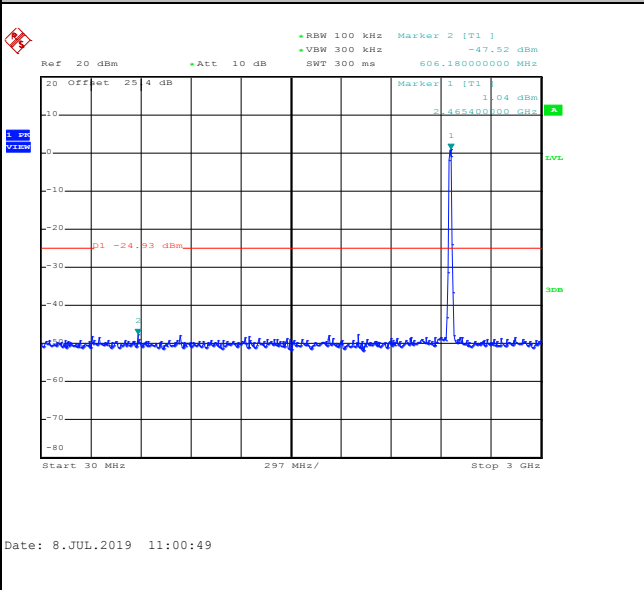



Test Mode :	802.11ac VHT20	Test Channel :	01
-------------	----------------	----------------	----

100kHz PSD reference Level	Low Channel Plot
-----------------------------------	-------------------------

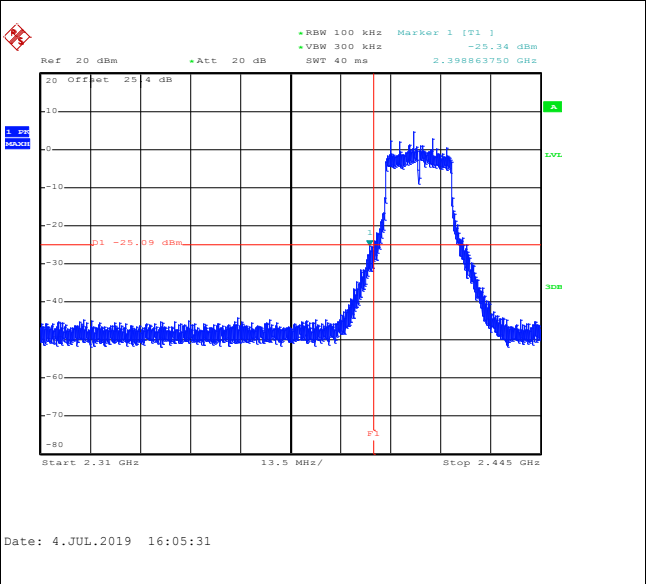
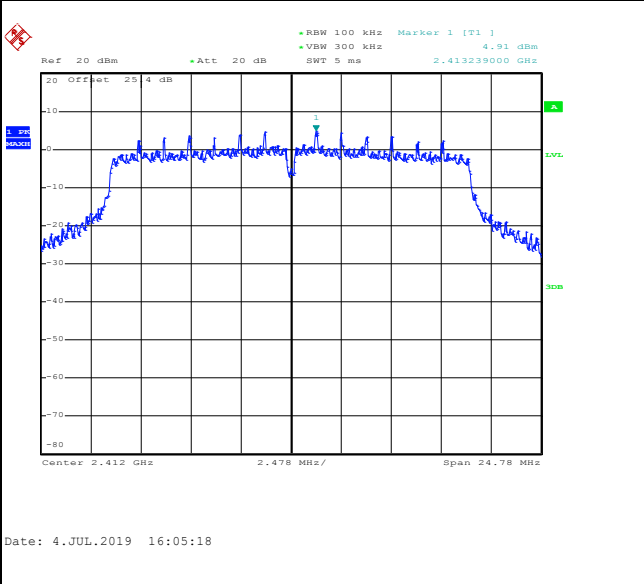

Spurious Emission 30MHz~3GHz	Spurious Emission 2GHz~25GHz
-------------------------------------	-------------------------------------

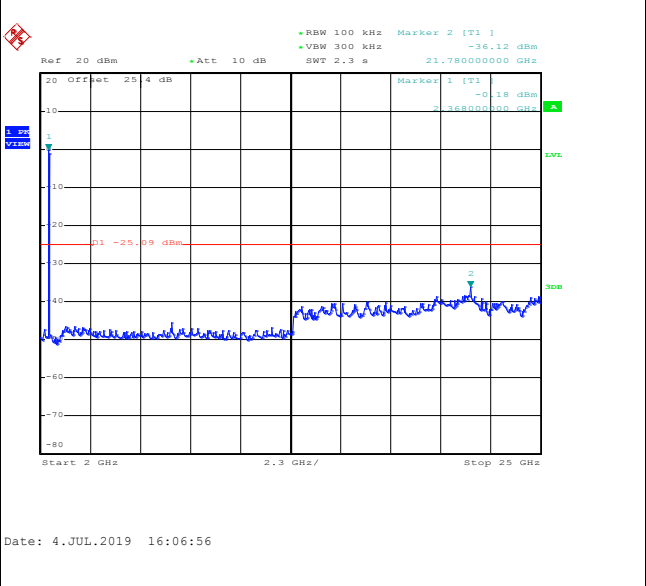
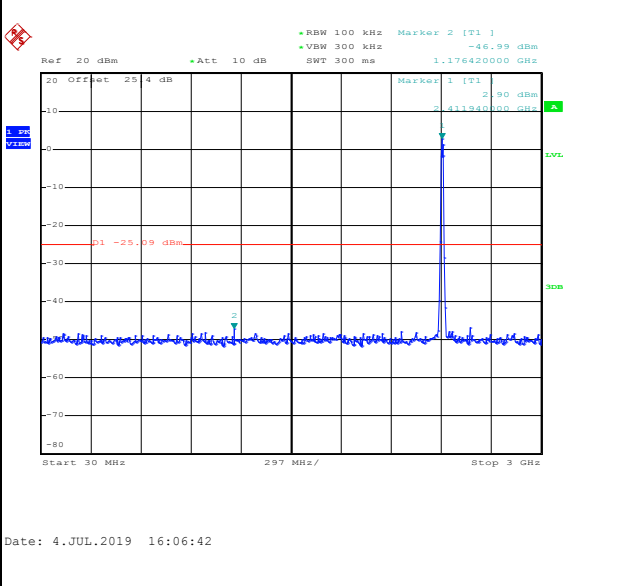



Test Mode :	802.11n HT20	Test Channel :	06
-------------	--------------	----------------	----

100kHz PSD reference Level	Mid Channel Plot
-----------------------------------	-------------------------

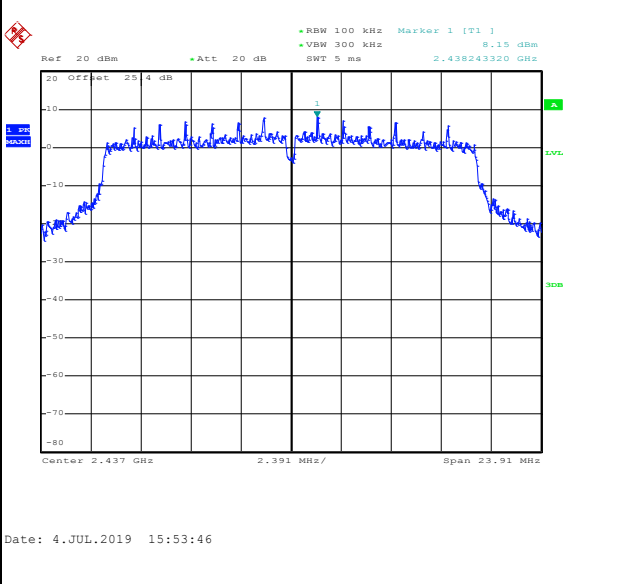

Spurious Emission 30MHz~3GHz	Spurious Emission 2GHz~25GHz
-------------------------------------	-------------------------------------

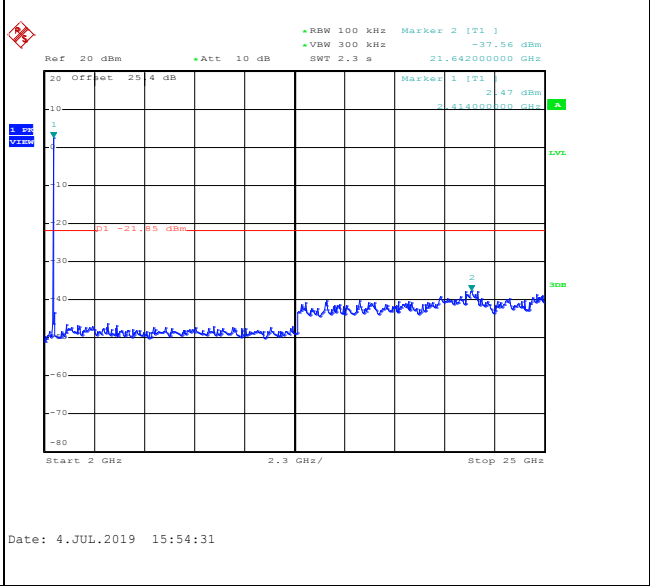
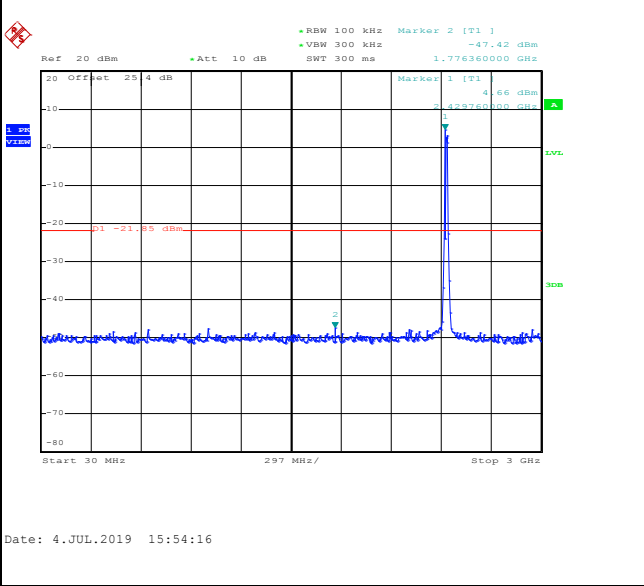



Test Mode :	802.11ac VHT20	Test Channel :	11
-------------	----------------	----------------	----

100kHz PSD reference Level	High Channel Plot
-----------------------------------	--------------------------

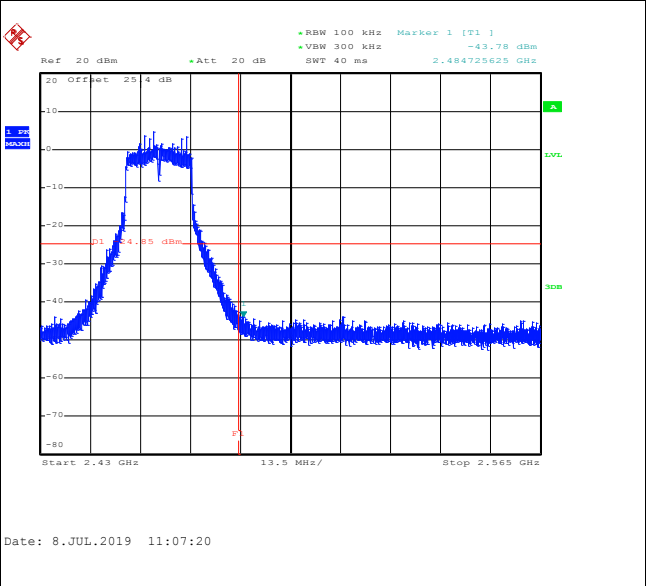
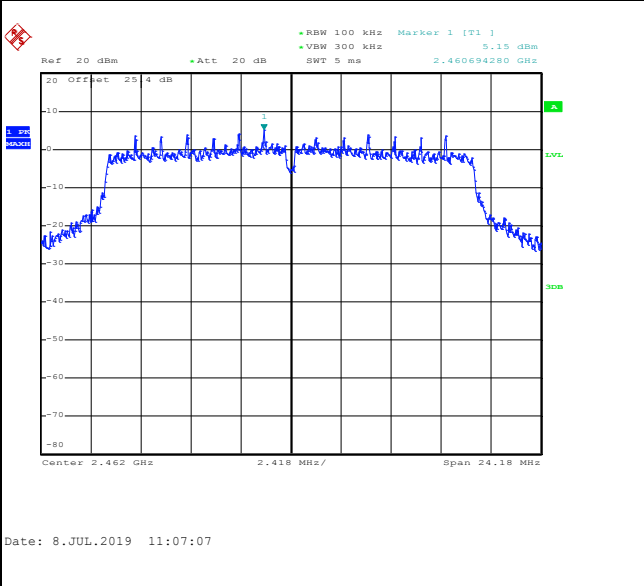

Spurious Emission 30MHz~3GHz	Spurious Emission 2GHz~25GHz
-------------------------------------	-------------------------------------

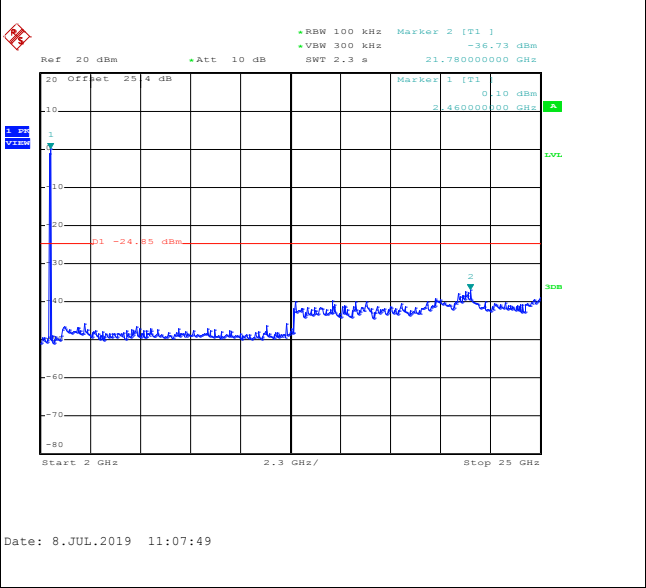
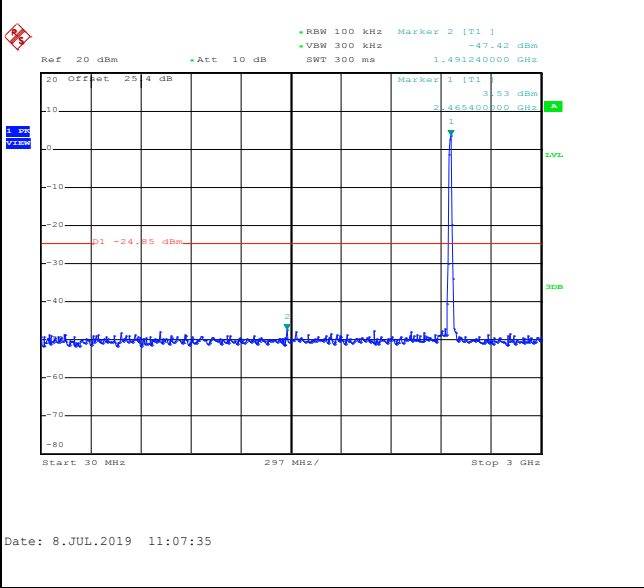



Number of TX = 2, Ant. 2 (Measured)

Test Mode :	802.11b	Test Channel :	01
-------------	---------	----------------	----

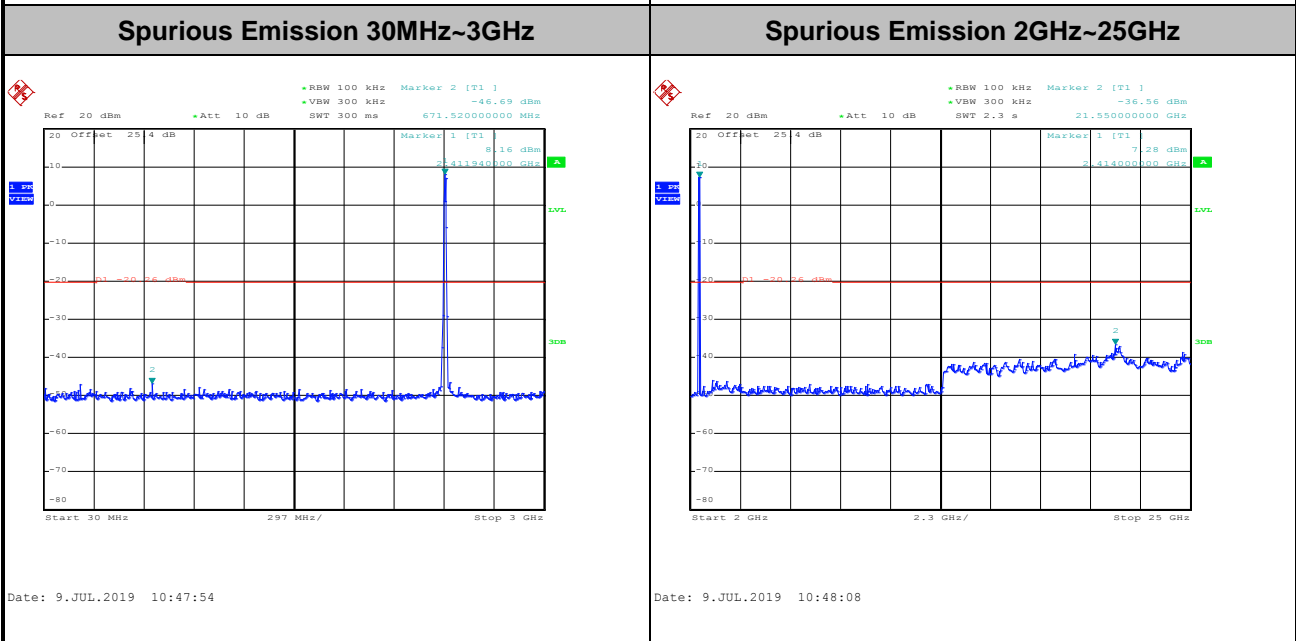
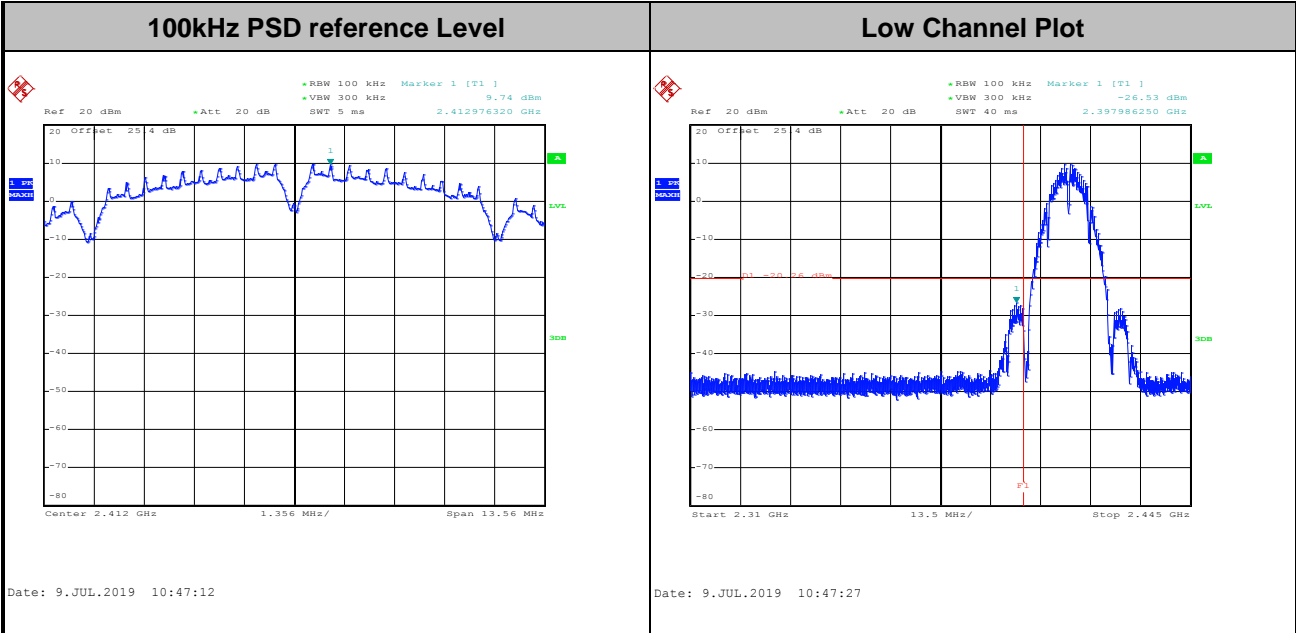



Test Mode :	802.11b	Test Channel :	06
-------------	---------	----------------	----

100kHz PSD reference Level	Mid Channel Plot
-----------------------------------	-------------------------

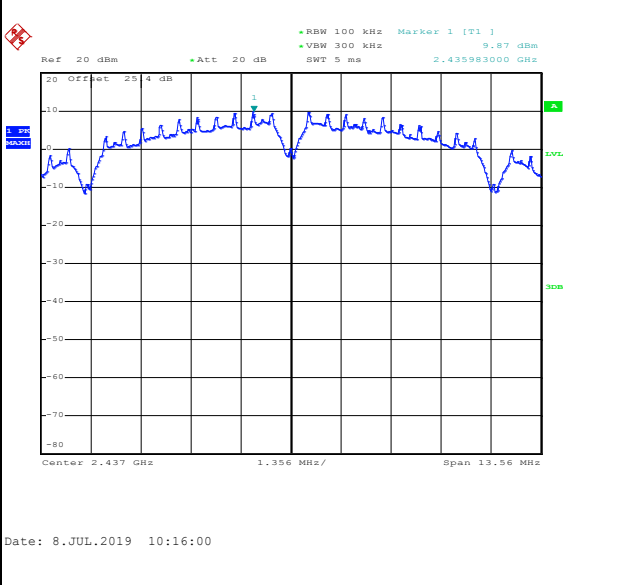

Spurious Emission 30MHz~3GHz	Spurious Emission 2GHz~25GHz
-------------------------------------	-------------------------------------

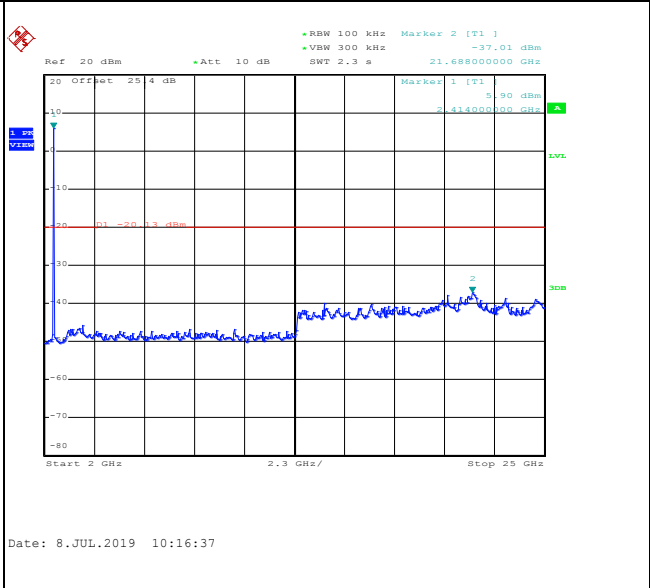
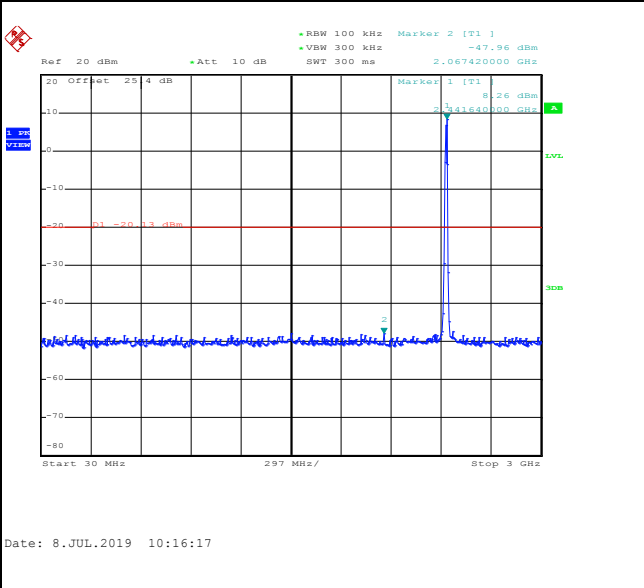



Test Mode :	802.11b	Test Channel :	11
-------------	---------	----------------	----

100kHz PSD reference Level	High Channel Plot
-----------------------------------	--------------------------

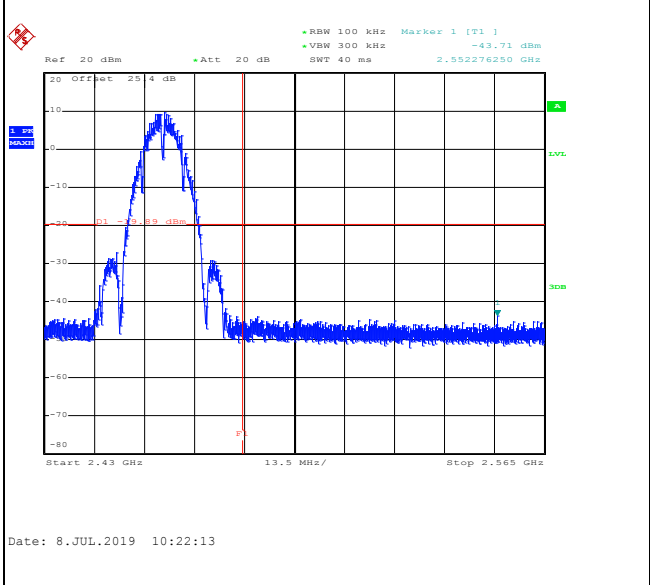
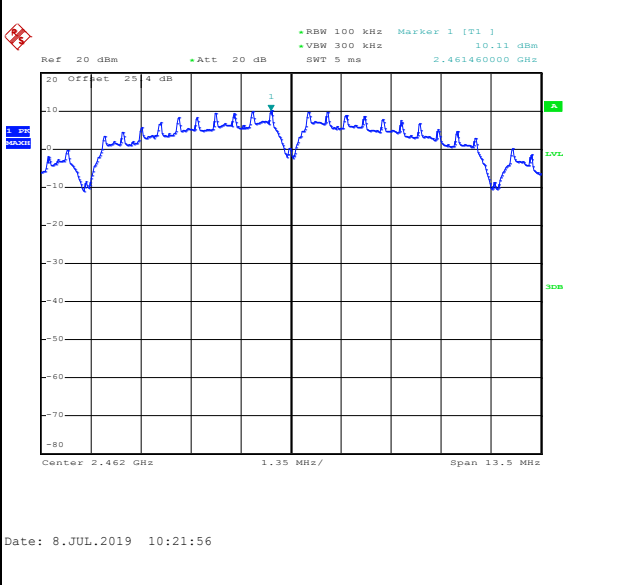

Spurious Emission 30MHz~3GHz	Spurious Emission 2GHz~25GHz
-------------------------------------	-------------------------------------

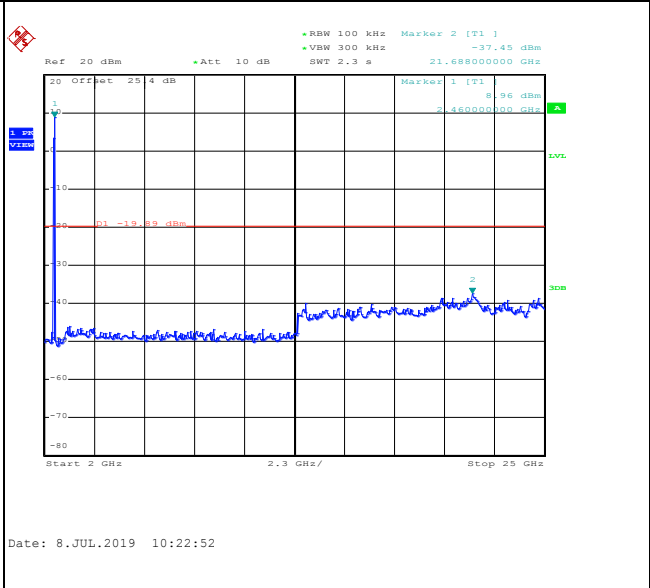
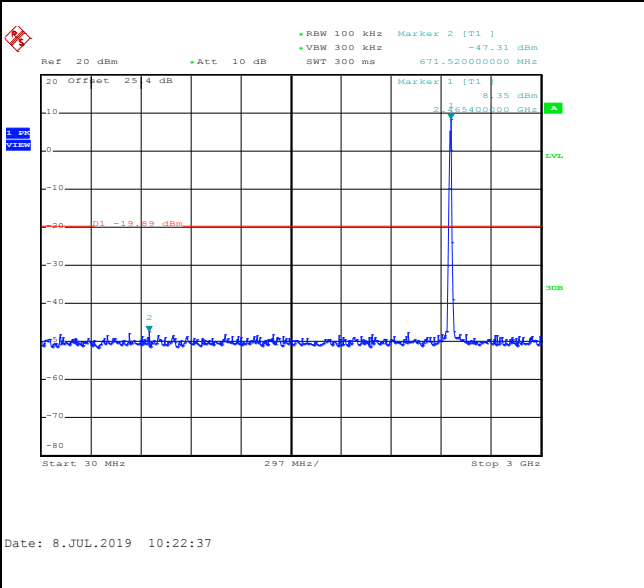



Test Mode :	802.11g	Test Channel :	01
-------------	---------	----------------	----

100kHz PSD reference Level	Low Channel Plot
-----------------------------------	-------------------------

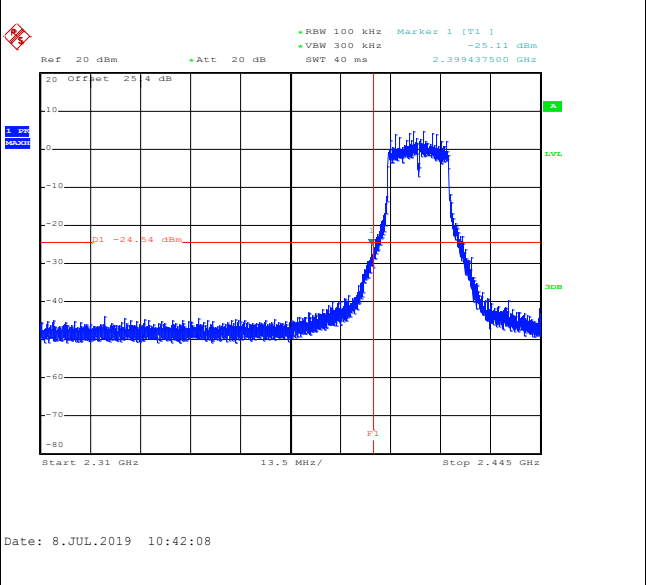
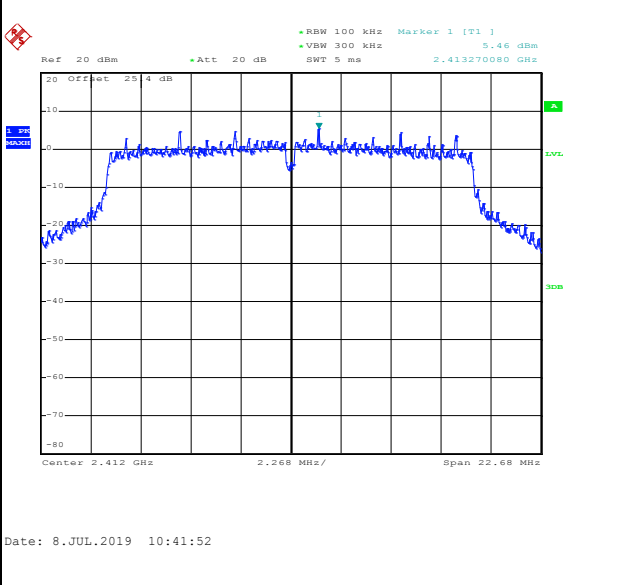

Spurious Emission 30MHz~3GHz	Spurious Emission 2GHz~25GHz
-------------------------------------	-------------------------------------

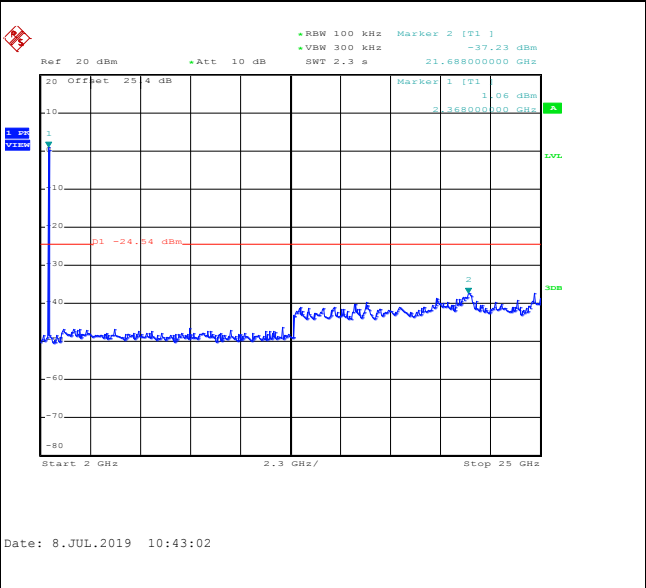
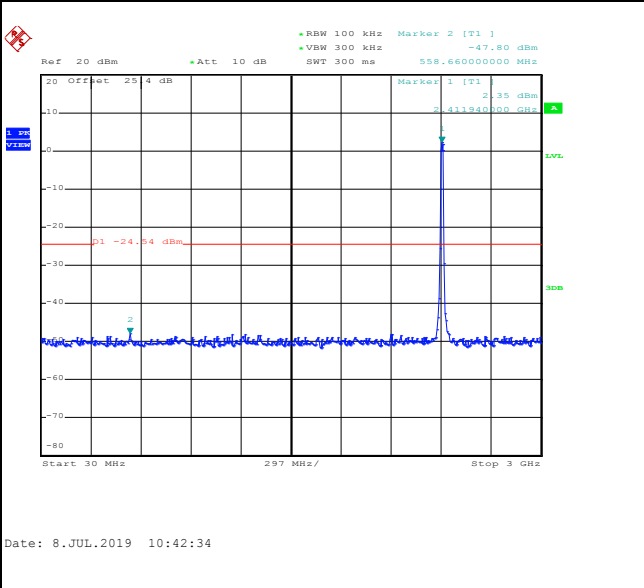



Test Mode :	802.11g	Test Channel :	06
-------------	---------	----------------	----

100kHz PSD reference Level	Mid Channel Plot
----------------------------	------------------

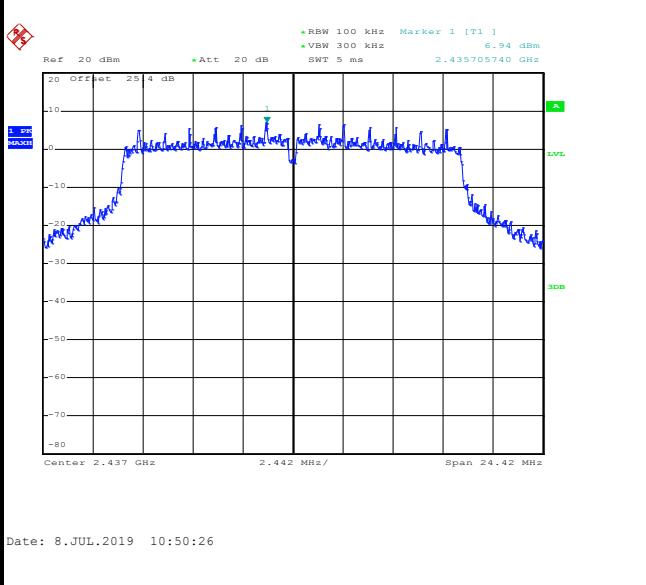

Spurious Emission 30MHz~3GHz	Spurious Emission 2GHz~25GHz
------------------------------	------------------------------

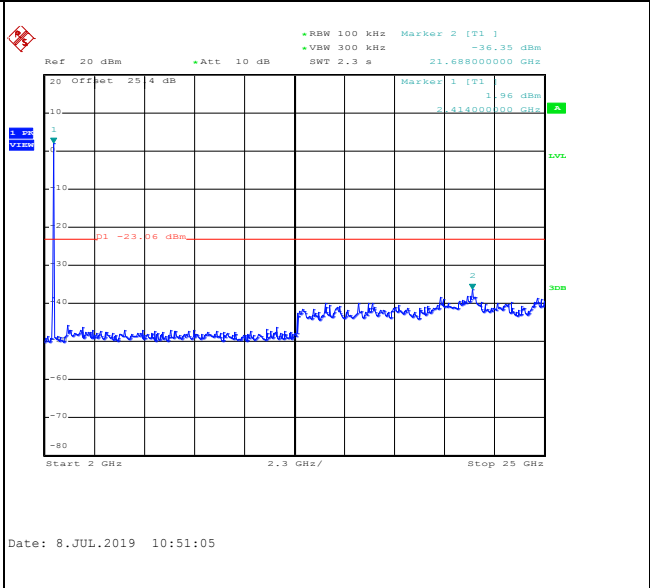
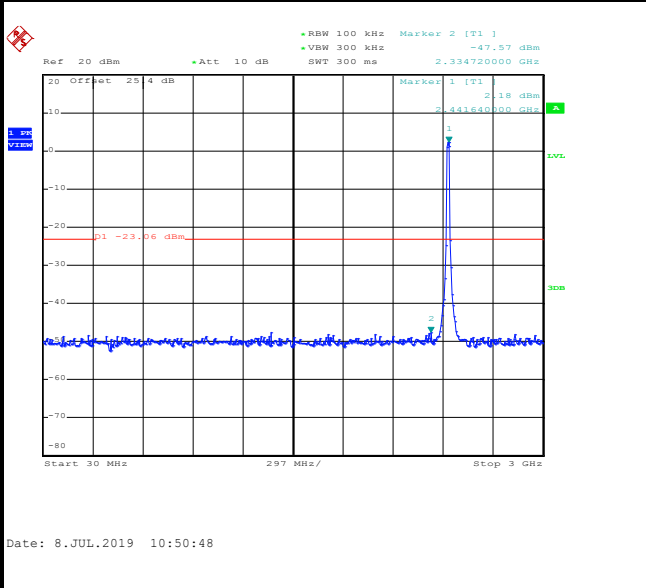



Test Mode :	802.11g	Test Channel :	11
-------------	---------	----------------	----

100kHz PSD reference Level	High Channel Plot
-----------------------------------	--------------------------

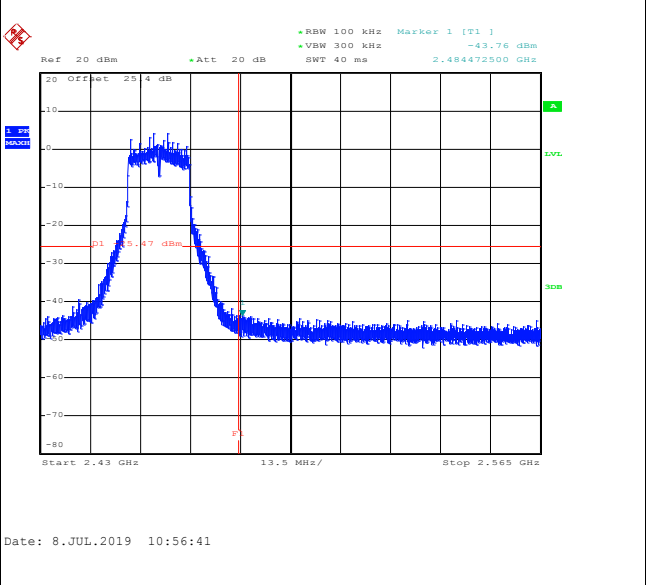
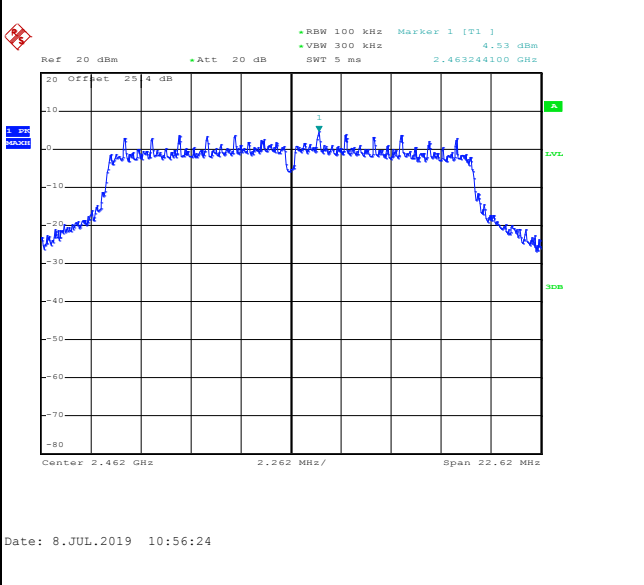

Spurious Emission 30MHz~3GHz	Spurious Emission 2GHz~25GHz
-------------------------------------	-------------------------------------

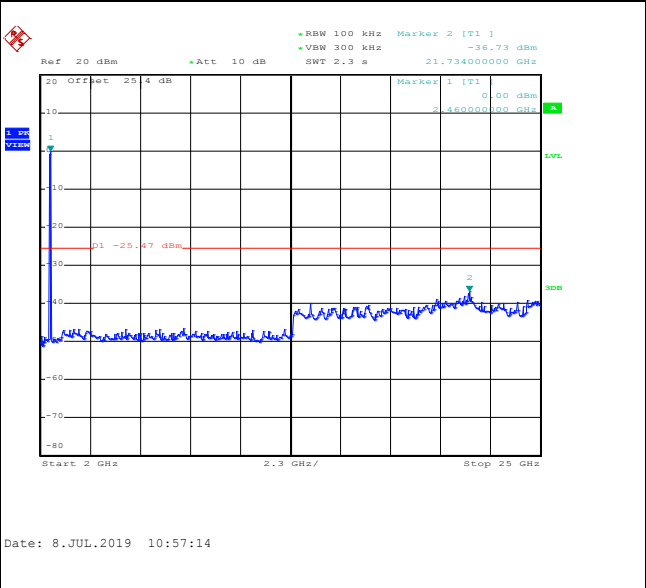
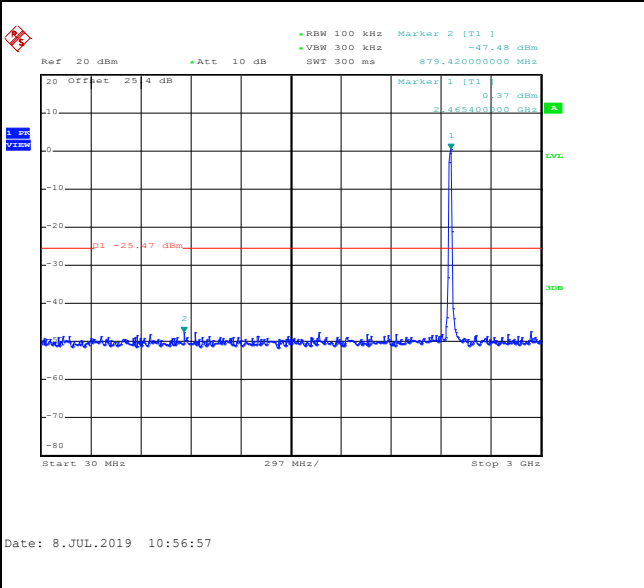



Test Mode :	802.11ac VHT20	Test Channel :	01
-------------	----------------	----------------	----

100kHz PSD reference Level	Low Channel Plot
-----------------------------------	-------------------------

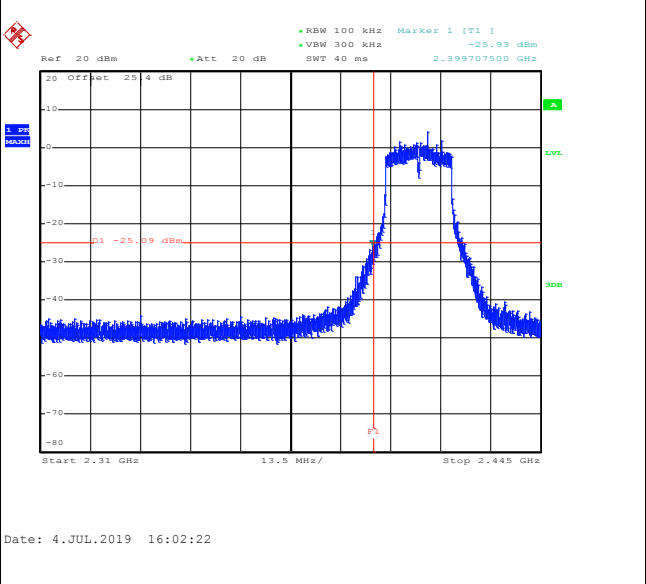
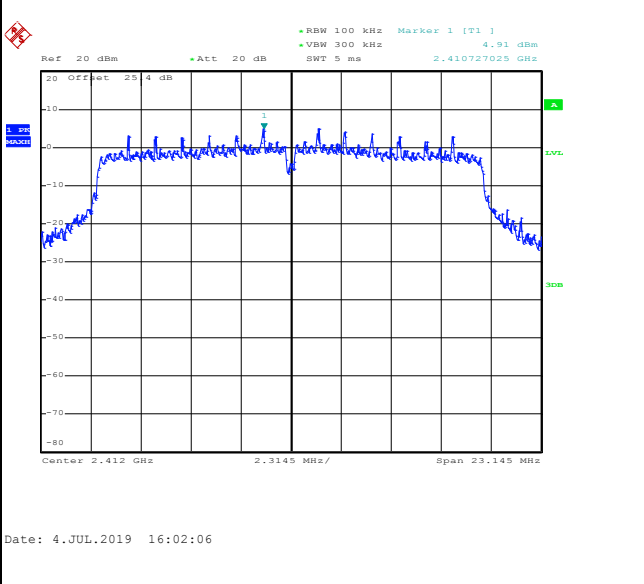

Spurious Emission 30MHz~3GHz	Spurious Emission 2GHz~25GHz
-------------------------------------	-------------------------------------

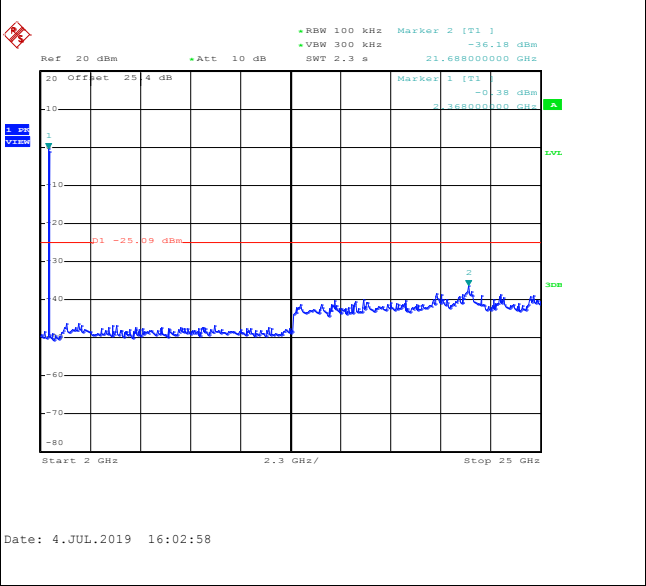
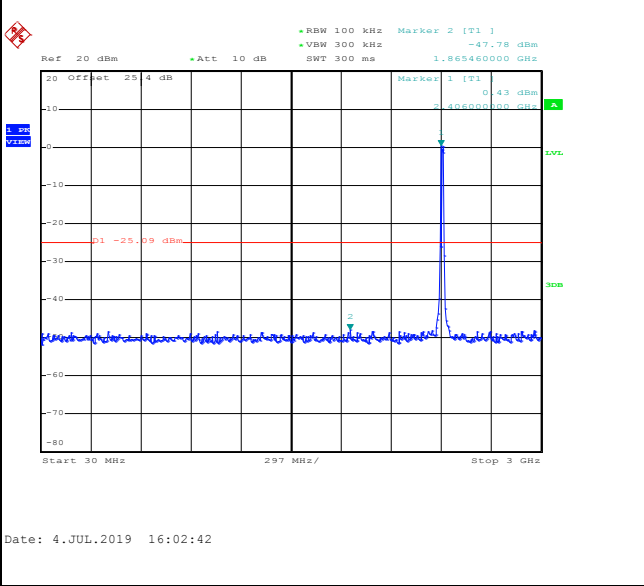



Test Mode :	802.11ac VHT20	Test Channel :	06
-------------	----------------	----------------	----

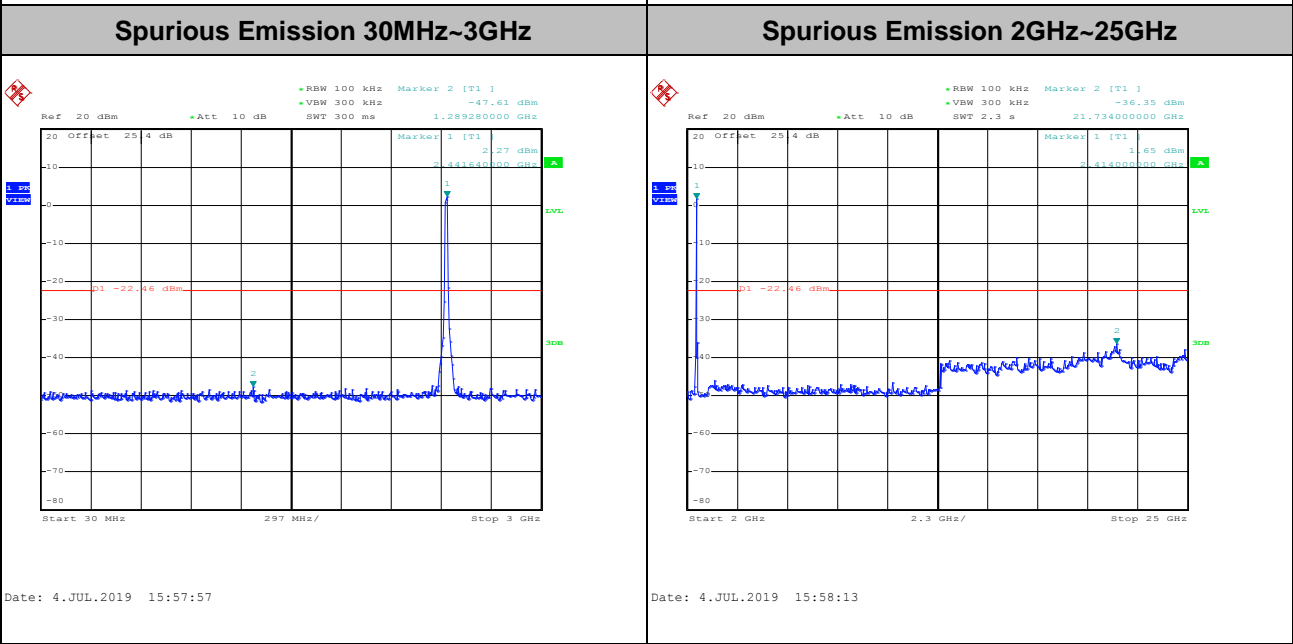
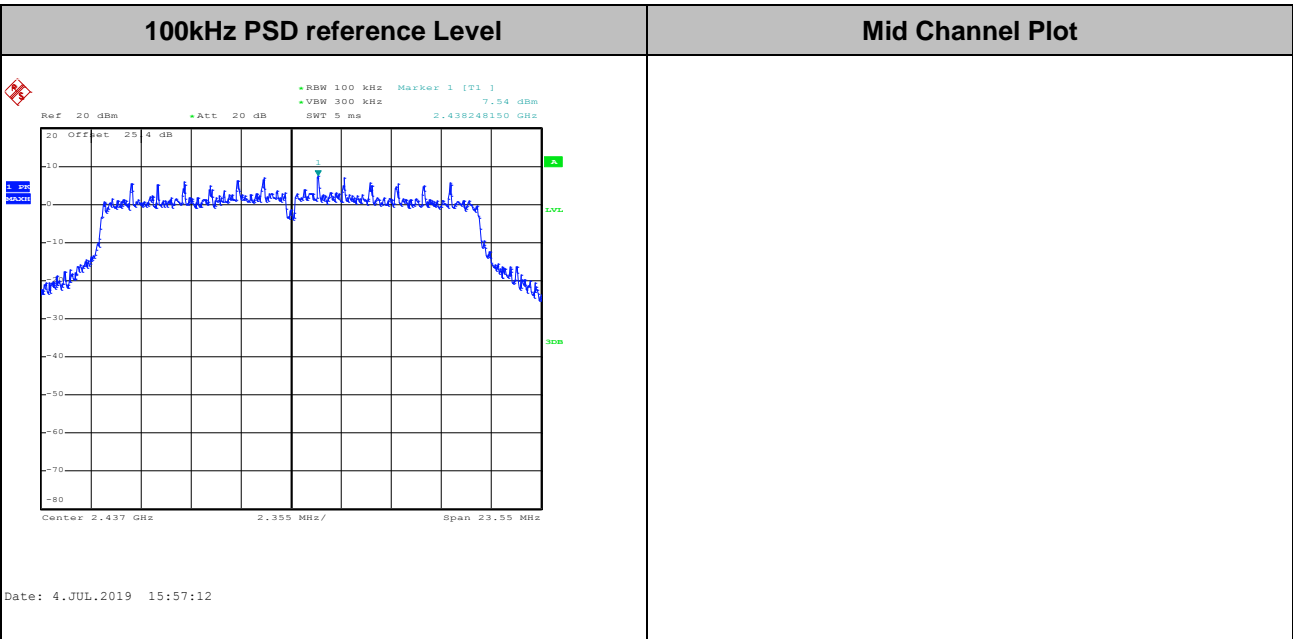



Test Mode :	802.11ac VHT20	Test Channel :	11
-------------	----------------	----------------	----

100kHz PSD reference Level	High Channel Plot
-----------------------------------	--------------------------

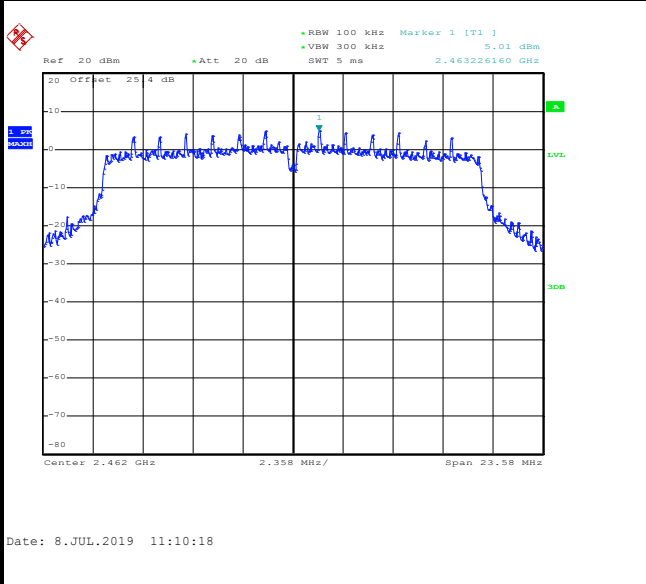

Date: 8.JUL.2019 11:10:18

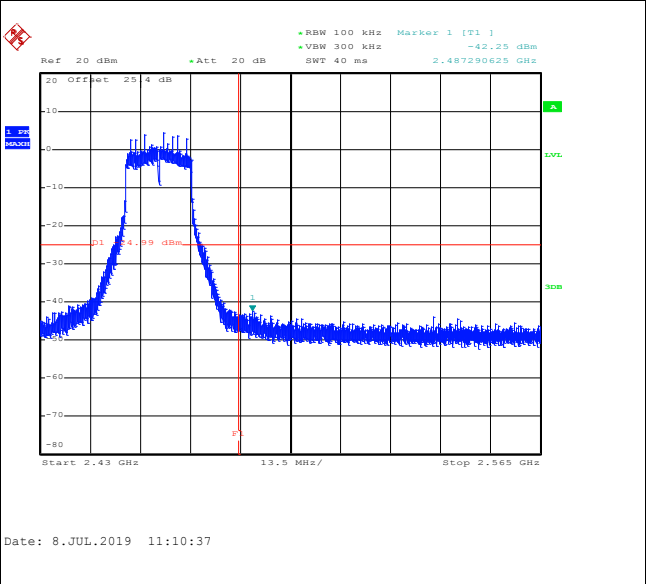

Date: 8.JUL.2019 11:10:37

Spurious Emission 30MHz~3GHz	Spurious Emission 2GHz~25GHz
-------------------------------------	-------------------------------------

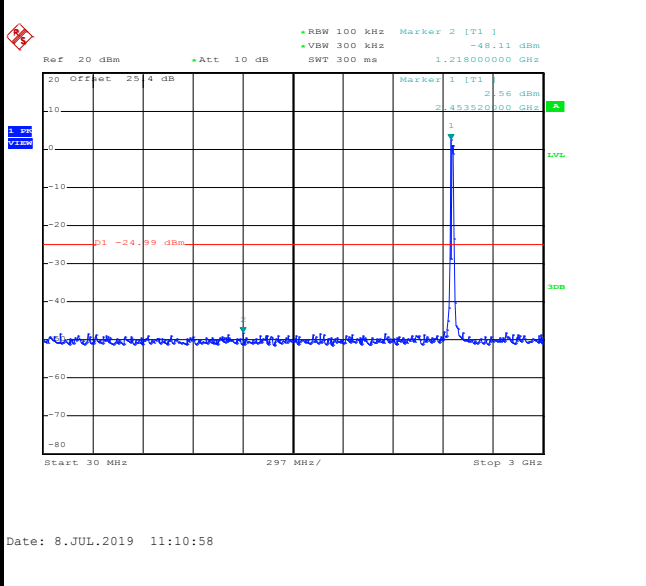

Date: 8.JUL.2019 11:10:58

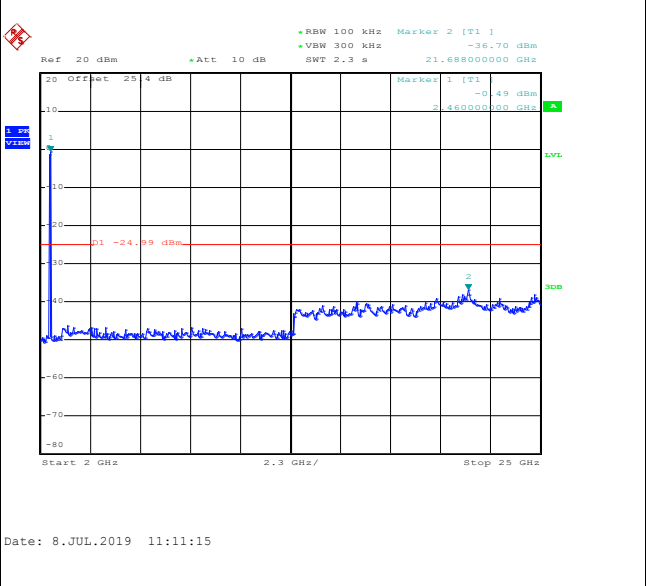

Date: 8.JUL.2019 11:11:15



3.5 Radiated Band Edges and Spurious Emission Measurement

3.5.1 Limit of Radiated band edge and Spurious Emission Measurement

In any 100 kHz bandwidth outside the intentional radiator frequency band, all harmonics/spurious must be at least 20 dB below the highest emission level within the authorized band. If the output power of this device was measured by spectrum analyzer, the attenuation under this paragraph shall be 30 dB instead of 20 dB. In addition, radiated emissions which fall in the restricted bands must also comply with the limits as below.

Frequency (MHz)	Field Strength (microvolts/meter)	Measurement Distance (meters)
0.009 – 0.490	2400/F(kHz)	300
0.490 – 1.705	24000/F(kHz)	30
1.705 – 30.0	30	30
30 – 88	100	3
88 – 216	150	3
216 - 960	200	3
Above 960	500	3

3.5.2 Measuring Instruments

See list of measuring equipment of this test report.



3.5.3 Test Procedures

1. The testing follows the ANSI C63.10 Section 11.12.1 Radiated emission measurements.
2. The EUT was arranged to its worst case and then tune the antenna tower (from 1 m to 4 m) and turntable (from 0 degree to 360 degrees) to find the maximum reading. A pre-amp and a high pass filter are used for the test in order to get better signal level.
3. The EUT was placed on a turntable with 0.8 meter for frequency below 1GHz and 1.5 meter for frequency above 1GHz respectively above ground.
4. The EUT was set 3 meters from the interference receiving antenna, which was mounted on the top of a variable height antenna tower.
5. Corrected Reading: Antenna Factor + Cable Loss + Read Level - Preamp Factor = Level
6. For testing below 1GHz, if the emission level of the EUT in peak mode was 3 dB lower than the limit specified, then peak values of EUT will be reported, otherwise, the emissions will be repeated one by one using the CISPR quasi-peak method and reported.
7. For testing above 1GHz, the emission level of the EUT in peak mode was 20dB lower than average limit (that means the emission level in average mode also complies with the limit in average mode), then peak values of EUT will be reported, otherwise, the emissions will be measured in average mode again and reported.
8. Use the following spectrum analyzer settings:
 - (1) Span shall wide enough to fully capture the emission being measured;
 - (2) Set RBW=100 kHz for $f < 1$ GHz; VBW = RBW; Sweep = auto; Detector function = peak; Trace = max hold;
 - (3) Set RBW = 1 MHz, VBW= 3MHz for $f \geq 1$ GHz for peak measurement.
For average measurement:
 - VBW = 10 Hz, when duty cycle is no less than 98 percent.
 - VBW $\geq 1/T$, when duty cycle is less than 98 percent where T is the minimum transmission duration over which the transmitter is on and is transmitting at its maximum power control level for the tested mode of operation.

3.5.4 Test Setup

For radiated emissions below 30MHz

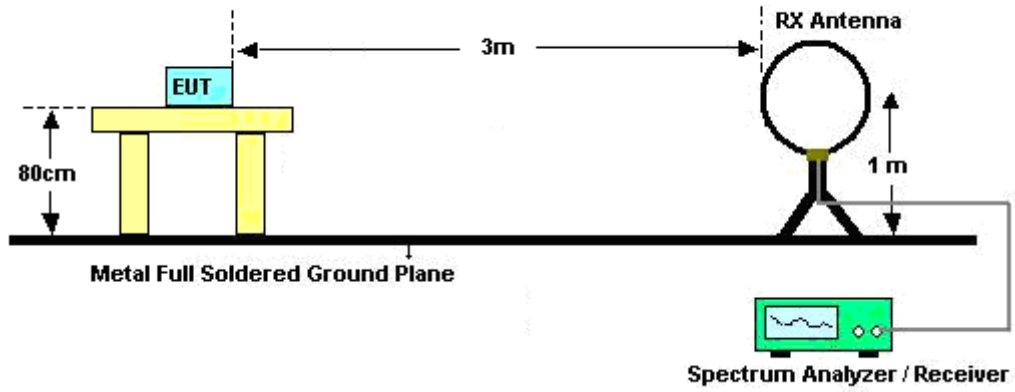

For radiated emissions from 30MHz to 1GHz

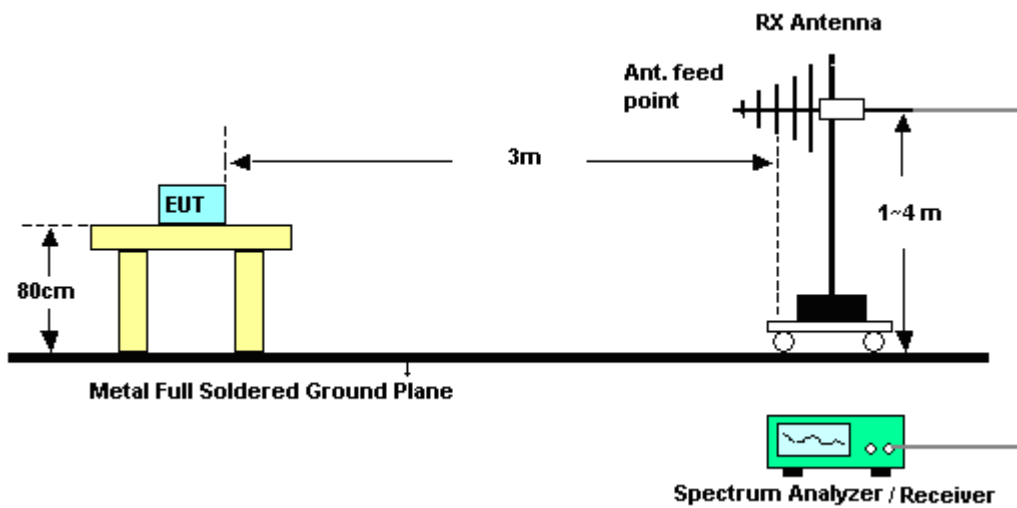

For radiated emissions above 1GHz



3.5.5 Test Results of Radiated Spurious Emissions (9kHz ~ 30MHz)

The low frequency, which started from 9 kHz to 30MHz, was pre-scanned and the result which was 20dB lower than the limit line was not reported.

There is a comparison data of both open-field test site and alternative test site - semi-Anechoic chamber according to 414788 D01 Radiated Test Site v01r01, and the result came out very similar.

3.5.6 Test Result of Radiated Spurious at Band Edges

Please refer to Appendix C and D.

3.5.7 Duty Cycle

Please refer to Appendix E.

3.5.8 Test Result of Radiated Spurious Emission (30MHz ~ 10th Harmonic)

Please refer to Appendix C and D.



3.6 AC Conducted Emission Measurement

3.6.1 Limit of AC Conducted Emission

For equipment that is designed to be connected to the public utility (AC) power line, the radio frequency voltage that is conducted back onto the AC power line on any frequency or frequencies within the band 150 kHz to 30 MHz shall not exceed the limits in the following table.

Frequency of Emission (MHz)	Conducted Limit (dBµV)	
	Quasi-Peak	Average
0.15-0.5	66 to 56*	56 to 46*
0.5-5	56	46
5-30	60	50

*Decreases with the logarithm of the frequency.

3.6.2 Measuring Instruments

See list of measuring equipment of this test report.

3.6.3 Test Procedures

1. The EUT was placed 0.4 meter from the conducting wall of the shielding room, and it was kept at least 80 centimeters from any other grounded conducting surface.
2. Connect EUT to the power mains through a line impedance stabilization network (LISN).
3. All the support units are connecting to the other LISN.
4. The LISN provides 50 ohm coupling impedance for the measuring instrument.
5. The FCC states that a 50 ohm, 50 microhenry LISN should be used.
6. Both sides of AC line were checked for maximum conducted interference.
7. The frequency range from 150 kHz to 30 MHz was searched.
8. Set the test-receiver system to Peak Detect Function and specified bandwidth (IF bandwidth = 9kHz) with Maximum Hold Mode.

3.6.4 Test Setup



3.6.5 Test Result of AC Conducted Emission

Please refer to Appendix B.



3.7 Antenna Requirements

3.7.1 Standard Applicable

If directional gain of transmitting Antennas is greater than 6dBi, the power shall be reduced by the same level in dB comparing to gain minus 6dBi. The use of a permanently attached Antenna or of an Antenna that uses a unique coupling to the intentional radiator shall be considered sufficient to comply with the rule.

3.7.2 Antenna Anti-Replacement Construction

An embedded-in antenna design is used.

3.7.3 Antenna Gain

<CDD Modes >

FCC KDB 662911 D01 Multiple Transmitter Output **v02r01**

For CDD transmissions, directional gain is calculated as

Directional gain = G_{ANT} + Array Gain, where Array Gain is as follows.

For power spectral density (PSD) measurements on all devices,

Array Gain = $10 \log(N_{ANT}/N_{SS}=1)$ dB.

For power measurements on IEEE 802.11 devices,

Array Gain = 0 dB (i.e., no array gain) for $N_{ANT} \leq 4$.

Directional gain may be calculated by using the formulas applicable to equal gain antennas with G_{ANT} set equal to the gain of the antenna having the highest gain;

The EUT supports CDD mode.

For power, the directional gain G_{ANT} is set equal to the antenna having the highest gain, i.e., F)2)f)i).

For PSD, the directional gain calculation is following F)2)f)ii) of KDB 662911 D01 **v02r01**.

The power and PSD limit should be modified if the directional gain of EUT is over 6 dBi,

The directional gain "DG" is calculated as following table.

<CDD Modes>						
			DG for Power (dBi)	DG for PSD (dBi)	Power Limit Reduction (dB)	PSD Limit Reduction (dB)
	Ant. 1 (dBi)	Ant. 2 (dBi)				
2.4 GHz	1.90	1.90	1.90	4.91	0.00	0.00

$Power\ Limit\ Reduction = DG(Power) - 6dBi, (min = 0)$

$PSD\ Limit\ Reduction = DG(PSD) - 6dBi, (min = 0)$



4 List of Measuring Equipment

Instrument	Manufacturer	Model No.	Serial No.	Characteristics	Calibration Date	Test Date	Due Date	Remark
Loop Antenna	Rohde & Schwarz	HFH2-Z2	100488	9 kHz~30 MHz	Jan. 07, 2019	Jun. 28, 2019~ Jul. 03, 2019	Jan. 06, 2020	Radiation (03CH12-HY)
Bilog Antenna	TESEQ	CBL 6111D&00800 N1D01N-06	37059&01	30MHz~1GHz	Oct. 13, 2018	Jun. 28, 2019~ Jul. 03, 2019	Oct. 12, 2019	Radiation (03CH12-HY)
Horn Antenna	SCHWARZBE CK	BBHA 9120D	9120D-132 8	1GHz ~ 18GHz	Nov. 09, 2018	Jun. 28, 2019~ Jul. 03, 2019	Nov. 08, 2019	Radiation (03CH12-HY)
SHF-EHF Horn Antenna	SCHWARZBE CK	BBHA 9170	BBHA9170 584	18GHz ~ 40GHz	Dec. 05, 2018	Jun. 28, 2019~ Jul. 03, 2019	Dec. 04, 2019	Radiation (03CH12-HY)
Preamplifier	COM-POWER	PA-103	161075	10MHz~1GHz	Mar. 25, 2019	Jun. 28, 2019~ Jul. 03, 2019	Mar. 24, 2020	Radiation (03CH12-HY)
Preamplifier	Agilent	8449B	3008A023 75	1GHz~26.5GHz	May 27, 2019	Jun. 28, 2019~ Jul. 03, 2019	May 26, 2020	Radiation (03CH12-HY)
Preamplifier	MITEQ	AMF-7D-0010 1800-30-10P	1590074	1GHz~18GHz	May 20, 2019	Jun. 28, 2019~ Jul. 03, 2019	May 19, 2020	Radiation (03CH12-HY)
Preamplifier	EMEC	EM18G40G	060715	18GHz ~ 40GHz	Dec. 06, 2018	Jun. 28, 2019~ Jul. 03, 2019	Dec. 05, 2019	Radiation (03CH12-HY)
EMI Test Receiver	Rohde & Schwarz	ESU26	100390	20Hz~26.5GHz	Dec. 26, 2018	Jun. 28, 2019~ Jul. 03, 2019	Dec. 25, 2019	Radiation (03CH12-HY)
Spectrum Analyzer	Keysight	N9010A	MY553705 26	10Hz~44GHz	Mar. 19, 2019	Jun. 28, 2019~ Jul. 03, 2019	Mar. 18, 2020	Radiation (03CH12-HY)
Filter	Wainwright	WLK4-1000-1 530-6000-40S S	SN11	1 GHz Lowpass	Sep. 16, 2018	Jun. 28, 2019~ Jul. 03, 2019	Sep. 15, 2019	Radiation (03CH12-HY)
Filter	Wainwright	WHKX12-270 0-3000-18000 -60SS	SN3	3 GHz Highpass	Sep. 16, 2018	Jun. 28, 2019~ Jul. 03, 2019	Sep. 15, 2019	Radiation (03CH12-HY)
RF Cable	HUBER + SUHNER	SUCOFLEX 126E	0058/126E	30M-18G	Mar. 13, 2019	Jun. 28, 2019~ Jul. 03, 2019	Mar. 12, 2020	Radiation (03CH12-HY)
RF Cable	HUBER + SUHNER	SUCOFLEX 102	505134/2	30M~40GHz	Oct. 16, 2018	Jun. 28, 2019~ Jul. 03, 2019	Oct. 15, 2019	Radiation (03CH12-HY)
RF Cable	HUBER + SUHNER	SUCOFLEX 102	800740/2	30M~40GHz	Oct. 16, 2018	Jun. 28, 2019~ Jul. 03, 2019	Oct. 15, 2019	Radiation (03CH12-HY)
Antenna Mast	EMEC	AM-BS-4500- B	N/A	1m~4m	N/A	Jun. 28, 2019~ Jul. 03, 2019	N/A	Radiation (03CH12-HY)
Turn Table	EMEC	TT2000	N/A	0~360 Degree	N/A	Jun. 28, 2019~ Jul. 03, 2019	N/A	Radiation (03CH12-HY)
Software	Audix	E3 6.2009-8-24	RK-00098 9	N/A	N/A	Jun. 28, 2019~ Jul. 03, 2019	N/A	Radiation (03CH12-HY)



Instrument	Manufacturer	Model No.	Serial No.	Characteristics	Calibration Date	Test Date	Due Date	Remark
Power Sensor	DARE	RPR3006W	13I00030S NO32	9kHz~6GHz	Dec. 03, 2018	Jun. 10, 2019~ Jul. 09, 2019	Dec. 02, 2019	Conducted (TH05-HY)
Spectrum Analyzer	Rohde & Schwarz	FSP40	100057	9kHz~40GHz	Nov. 21, 2018	Jun. 10, 2019~ Jul. 09, 2019	Nov. 20, 2019	Conducted (TH05-HY)
Switch Box & RF Cable	Burgeon	ETF-058	EC120838 2	N/A	Mar. 27, 2019	Jun. 10, 2019~ Jul. 09, 2019	Mar. 26, 2020	Conducted (TH05-HY)
AC Power Source	ChainTek	APC-1000W	N/A	N/A	N/A	Jul. 01, 2019	N/A	Conduction (CO05-HY)
EMI Test Receiver	Rohde & Schwarz	ESR3	102388	9kHz~3.6GHz	Nov. 12, 2018	Jul. 01, 2019	Nov. 11, 2019	Conduction (CO05-HY)
LISN	Rohde & Schwarz	ENV216	100080	9kHz~30MHz	Nov. 14, 2018	Jul. 01, 2019	Nov. 13, 2019	Conduction (CO05-HY)
LISN	Rohde & Schwarz	ENV216	100081	9kHz~30MHz	Nov. 09, 2018	Jul. 01, 2019	Nov. 08, 2019	Conduction (CO05-HY)
Software	Rohde & Schwarz	EMC32 V10.30	N/A	N/A	N/A	Jul. 01, 2019	N/A	Conduction (CO05-HY)
LF Cable	HUBER + SUHNER	RG-214/U	LF01	N/A	Dec. 31, 2018	Jul. 01, 2019	Dec. 30, 2019	Conduction (CO05-HY)
Pulse Limiter	Rohde & Schwarz	ESH3-Z2	100851	N/A	Dec. 31, 2018	Jul. 01, 2019	Dec. 30, 2019	Conduction (CO05-HY)



5 Uncertainty of Evaluation

Uncertainty of Conducted Emission Measurement (150kHz ~ 30MHz)

Measuring Uncertainty for a Level of Confidence of 95% ($U = 2Uc(y)$)	2.2
---	-----

Uncertainty of Radiated Emission Measurement (30 MHz ~ 1000 MHz)

Measuring Uncertainty for a Level of Confidence of 95% ($U = 2Uc(y)$)	5.1
---	-----

Uncertainty of Radiated Emission Measurement (1000 MHz ~ 18000 MHz)

Measuring Uncertainty for a Level of Confidence of 95% ($U = 2Uc(y)$)	5.2
---	-----

Uncertainty of Radiated Emission Measurement (18000 MHz ~ 40000 MHz)

Measuring Uncertainty for a Level of Confidence of 95% ($U = 2Uc(y)$)	4.7
---	-----

Appendix A. Test Result of Conducted Test Items

Test Engineer:	Richard Qiu	Temperature:	21~25	°C
Test Date:	2019/6/10~2019/7/9	Relative Humidity:	51~54	%
TX Tool	QRCT 4.0	TX Tool Version		

TEST RESULTS DATA
6dB and 99% Occupied Bandwidth

2.4GHz Band										
Mod.	Data Rate	NTX	CH.	Freq. (MHz)	99% Occupied BW (MHz)		6dB BW (MHz)		6dB BW Limit (MHz)	Pass/Fail
					Ant 1	Ant 2	Ant 1	Ant 2		
11b	1Mbps	2	1	2412	13.95	14.50	9.04	9.04	0.50	Pass
11b	1Mbps	2	6	2437	13.95	14.30	9.04	9.04	0.50	Pass
11b	1Mbps	2	11	2462	13.95	14.40	8.04	9.00	0.50	Pass
11g	6Mbps	2	1	2412	16.75	16.65	15.32	15.12	0.50	Pass
11g	6Mbps	2	6	2437	16.70	16.70	15.99	16.28	0.50	Pass
11g	6Mbps	2	11	2462	16.80	16.65	15.08	15.08	0.50	Pass
VHT20	MCS0	2	1	2412	17.95	17.80	16.52	15.43	0.50	Pass
VHT20	MCS0	2	6	2437	17.95	17.90	15.94	15.70	0.50	Pass
VHT20	MCS0	2	11	2462	17.95	17.85	16.12	15.72	0.50	Pass

TEST RESULTS DATA
Average Output Power

2.4GHz Band																
Mod.	Data Rate	NTx	CH.	Freq. (MHz)	Average Conducted Power (dBm)			Conducted Power Limit (dBm)		DG (dBi)		EIRP Power (dBm)		EIRP Power Limit (dBm)		Pass /Fail
					Ant 1	Ant 2	SUM	Ant 1	Ant 2	Ant 1	Ant 2	Ant 1	Ant 2	Ant 1	Ant 2	
11b	1Mbps	1	1	2412	19.20	18.50		30.00	30.00	1.90	1.90	21.10	20.40	36.00	36.00	Pass
11b	1Mbps	1	6	2437	19.00	18.30		30.00	30.00	1.90	1.90	20.90	20.20	36.00	36.00	Pass
11b	1Mbps	1	11	2462	19.30	18.80		30.00	30.00	1.90	1.90	21.20	20.70	36.00	36.00	Pass
11g	6Mbps	1	1	2412	15.80	15.90		30.00	30.00	1.90	1.90	17.70	17.80	36.00	36.00	Pass
11g	6Mbps	1	6	2437	17.50	17.00		30.00	30.00	1.90	1.90	19.40	18.90	36.00	36.00	Pass
11g	6Mbps	1	11	2462	14.70	14.80		30.00	30.00	1.90	1.90	16.60	16.70	36.00	36.00	Pass
HT20	MCS0	1	1	2412	14.40	14.70		30.00	30.00	1.90	1.90	16.30	16.60	36.00	36.00	Pass
HT20	MCS0	1	6	2437	17.00	17.00		30.00	30.00	1.90	1.90	18.90	18.90	36.00	36.00	Pass
HT20	MCS0	1	11	2462	15.20	15.00		30.00	30.00	1.90	1.90	17.10	16.90	36.00	36.00	Pass
VHT20	MCS0	1	1	2412	14.50	14.80		30.00	30.00	1.90	1.90	16.40	16.70	36.00	36.00	Pass
VHT20	MCS0	1	6	2437	17.10	17.10		30.00	30.00	1.90	1.90	19.00	19.00	36.00	36.00	Pass
VHT20	MCS0	1	11	2462	15.30	15.10		30.00	30.00	1.90	1.90	17.20	17.00	36.00	36.00	Pass
11b	1Mbps	2	1	2412	19.30	18.60	21.97	30.00		1.90		23.87		36.00		Pass
11b	1Mbps	2	6	2437	19.10	18.40	21.77	30.00		1.90		23.67		36.00		Pass
11b	1Mbps	2	11	2462	19.40	18.90	22.17	30.00		1.90		24.07		36.00		Pass
11g	6Mbps	2	1	2412	15.90	16.00	18.96	30.00		1.90		20.86		36.00		Pass
11g	6Mbps	2	6	2437	17.40	17.30	20.36	30.00		1.90		22.26		36.00		Pass
11g	6Mbps	2	11	2462	14.90	14.90	17.91	30.00		1.90		19.81		36.00		Pass
HT20	MCS0	2	1	2412	14.60	14.80	17.71	30.00		1.90		19.61		36.00		Pass
HT20	MCS0	2	6	2437	17.10	17.10	20.11	30.00		1.90		22.01		36.00		Pass
HT20	MCS0	2	11	2462	15.30	15.10	18.21	30.00		1.90		20.11		36.00		Pass
VHT20	MCS0	2	1	2412	14.70	14.90	17.81	30.00		1.90		19.71		36.00		Pass
VHT20	MCS0	2	6	2437	17.20	17.20	20.21	30.00		1.90		22.11		36.00		Pass
VHT20	MCS0	2	11	2462	15.40	15.20	18.31	30.00		1.90		20.21		36.00		Pass

Note: Measured power (dBm) has offset with cable loss.

TEST RESULTS DATA
Peak Power Spectral Density

2.4GHz Band												
Mod.	Data Rate	NTX	CH.	Freq. (MHz)	Peak PSD (dBm/3kHz)			DG (dBi)		Peak PSD Limit (dBm/3kHz)		Pass/Fail
					Ant 1	Ant 2	Worse + 3.01	Ant 1	Ant 2	Ant 1	Ant 2	
11b	1Mbps	2	1	2412	-3.94	-4.64	-0.93	4.91		8.00		Pass
11b	1Mbps	2	6	2437	-2.75	-4.13	0.26	4.91		8.00		Pass
11b	1Mbps	2	11	2462	-4.25	-4.08	-1.07	4.91		8.00		Pass
11g	6Mbps	2	1	2412	-7.72	-9.39	-4.71	4.91		8.00		Pass
11g	6Mbps	2	6	2437	-8.86	-8.94	-5.85	4.91		8.00		Pass
11g	6Mbps	2	11	2462	-10.69	-11.21	-7.68	4.91		8.00		Pass
VHT20	MCS0	2	1	2412	-10.93	-11.70	-7.92	4.91		8.00		Pass
VHT20	MCS0	2	6	2437	-8.19	-9.67	-5.18	4.91		8.00		Pass
VHT20	MCS0	2	11	2462	-11.47	-10.62	-7.61	4.91		8.00		Pass

Measured power density (dBm) has offset with cable loss.



Appendix B. AC Conducted Emission Test Results

Test Engineer :	Louis Chung	Temperature :	23~26°C
		Relative Humidity :	59.1~69.3%

EUT Information

Report NO : 952409
 Test Mode : Mode 1
 Test Voltage : 120Vac/60Hz
 Phase : Line

Full Spectrum

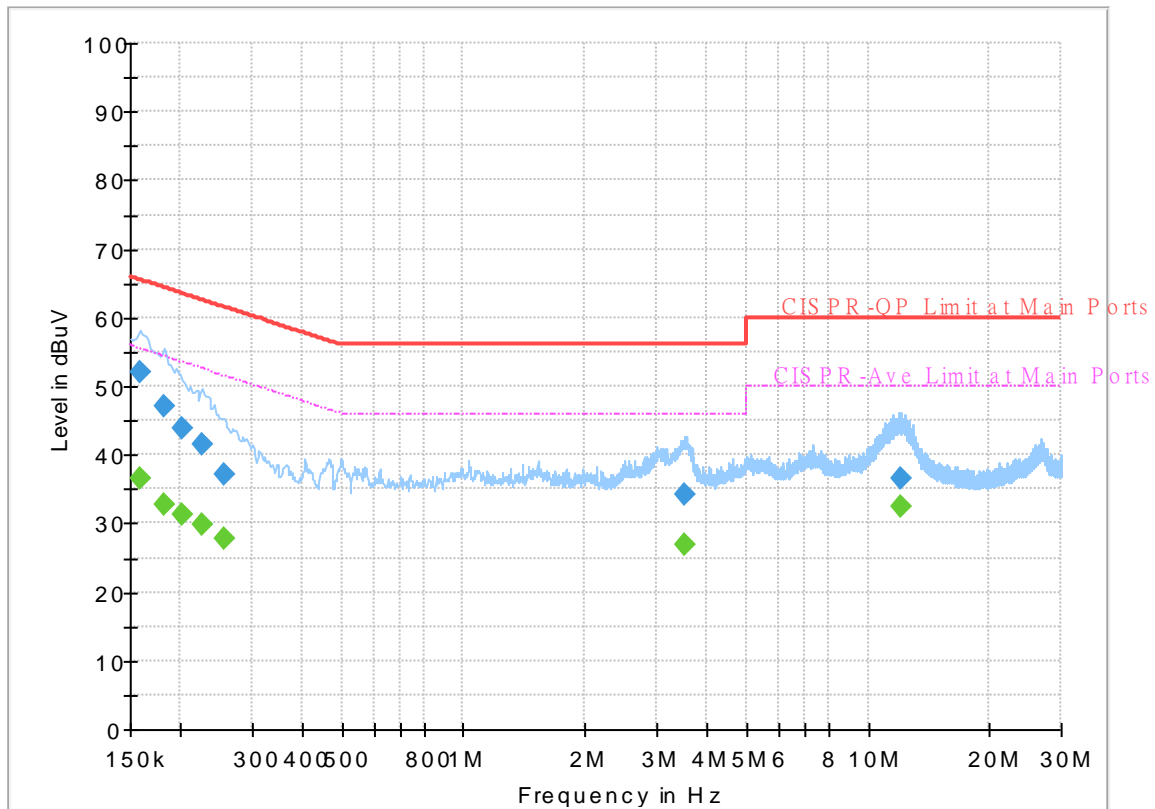

Final_Result

Frequency (MHz)	QuasiPeak (dBuV)	CAverage (dBuV)	Limit (dBuV)	Margin (dB)	Line	Filter	Corr. (dB)
0.159000	---	36.47	55.52	19.05	L1	OFF	19.4
0.159000	51.91	---	65.52	13.61	L1	OFF	19.4
0.181500	---	32.84	54.42	21.58	L1	OFF	19.4
0.181500	46.98	---	64.42	17.44	L1	OFF	19.4
0.201750	---	31.19	53.54	22.35	L1	OFF	19.4
0.201750	43.99	---	63.54	19.55	L1	OFF	19.4
0.226500	---	29.73	52.58	22.85	L1	OFF	19.4
0.226500	41.57	---	62.58	21.01	L1	OFF	19.4
0.255750	---	27.74	51.57	23.83	L1	OFF	19.4
0.255750	37.10	---	61.57	24.47	L1	OFF	19.4
3.516000	---	26.84	46.00	19.16	L1	OFF	19.6
3.516000	34.16	---	56.00	21.84	L1	OFF	19.6
12.039000	---	32.33	50.00	17.67	L1	OFF	19.9
12.039000	36.58	---	60.00	23.42	L1	OFF	19.9

EUT Information

Report NO : 952409
 Test Mode : Mode 1
 Test Voltage : 120Vac/60Hz
 Phase : Neutral

Full Spectrum

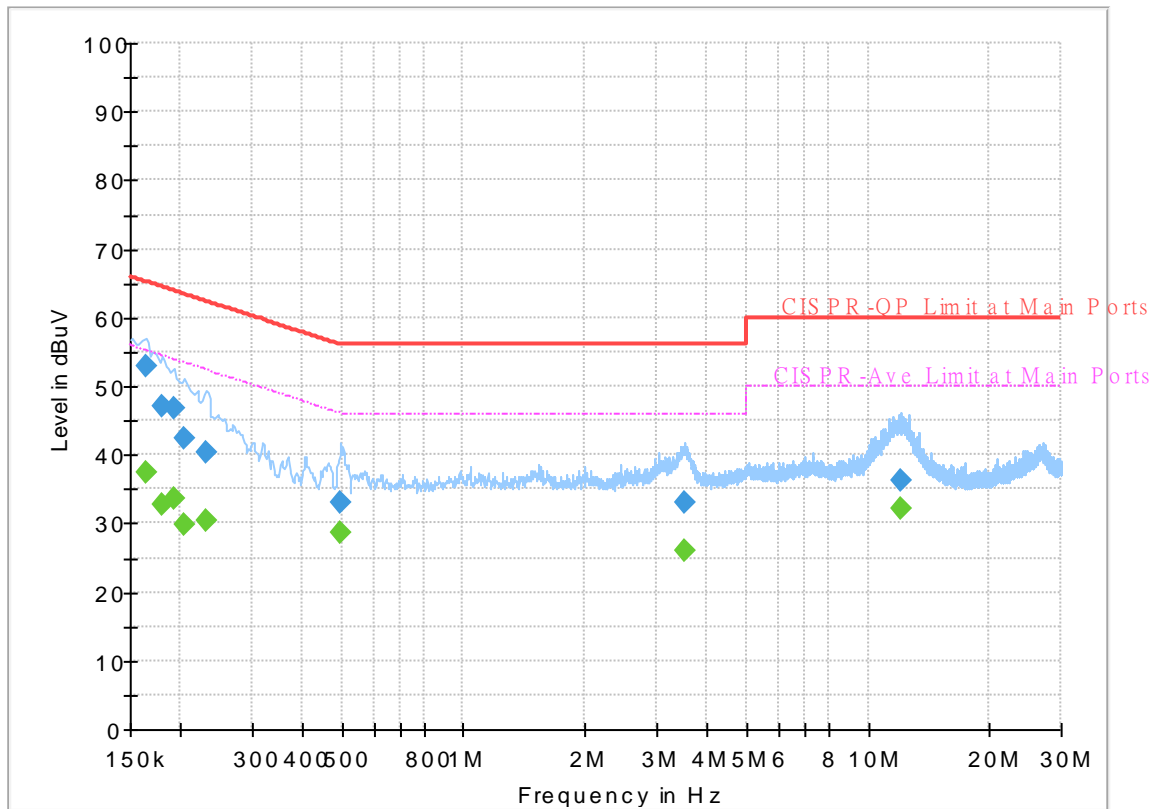

Final_Result

Frequency (MHz)	QuasiPeak (dBuV)	CAverage (dBuV)	Limit (dBuV)	Margin (dB)	Line	Filter	Corr. (dB)
0.163500	---	37.31	55.28	17.97	N	OFF	19.5
0.163500	52.96	---	65.28	12.32	N	OFF	19.5
0.179250	---	32.76	54.52	21.76	N	OFF	19.5
0.179250	47.08	---	64.52	17.44	N	OFF	19.5
0.192750	---	33.65	53.92	20.27	N	OFF	19.5
0.192750	46.72	---	63.92	17.20	N	OFF	19.5
0.204000	---	29.69	53.45	23.76	N	OFF	19.5
0.204000	42.41	---	63.45	21.04	N	OFF	19.5
0.231000	---	30.54	52.41	21.87	N	OFF	19.5
0.231000	40.48	---	62.41	21.93	N	OFF	19.5
0.498750	---	28.75	46.02	17.27	N	OFF	19.5
0.498750	32.91	---	56.02	23.11	N	OFF	19.5
3.518250	---	26.13	46.00	19.87	N	OFF	19.6
3.518250	32.90	---	56.00	23.10	N	OFF	19.6
12.039000	---	32.13	50.00	17.87	N	OFF	20.0
12.039000	36.24	---	60.00	23.76	N	OFF	20.0



Appendix C. Radiated Spurious Emission

Test Engineer :	Jack Cheng, Lance Chiang, Chuan Chu	Temperature :	21~24°C
		Relative Humidity :	56~68%

2.4GHz 2400~2483.5MHz

WIFI 802.11b (Band Edge @ 3m)

WIFI Ant.	Note	Frequency (MHz)	Level (dBμV/m)	Over Limit (dB)	Limit Line (dBμV/m)	Read Level (dBμV)	Antenna Factor (dB/m)	Path Loss (dB)	Preamp Factor (dB)	Ant Pos (cm)	Table Pos (deg)	Peak Avg. (P/A)	Pol. (H/V)	
802.11b CH 01 2412MHz		2390	57.09	-16.91	74	46.1	27.52	16.63	33.16	105	220	P	H	
		2389.275	45.8	-8.2	54	34.81	27.52	16.63	33.16	105	220	A	H	
	*	2412	112.07	-	-	101.12	27.48	16.65	33.18	105	220	P	H	
	*	2412	109.01	-	-	98.06	27.48	16.65	33.18	105	220	A	H	
													H	
														H
			2386.44	56.22	-17.78	74	45.22	27.53	16.62	33.15	284	276	P	V
			2387.175	46.61	-7.39	54	35.61	27.53	16.62	33.15	284	276	A	V
	*		2412	114.1	-	-	103.15	27.48	16.65	33.18	284	276	P	V
	*		2412	111.07	-	-	100.12	27.48	16.65	33.18	284	276	A	V
														V
														V



WIFI Ant. 1+2	Note	Frequency (MHz)	Level (dBμV/m)	Over Limit (dB)	Limit Line (dBμV/m)	Read Level (dBμV)	Antenna Factor (dB/m)	Path Loss (dB)	Preamp Factor (dB)	Ant Pos (cm)	Table Pos (deg)	Peak Avg. (P/A)	Pol. (H/V)
802.11b CH 06 2437MHz		2320.92	55.58	-18.42	74	44.34	27.77	16.55	33.08	100	222	P	H
		2389.94	45.04	-8.96	54	34.05	27.52	16.63	33.16	100	222	A	H
	*	2437	111.39	-	-	100.5	27.43	16.67	33.21	100	222	P	H
	*	2437	108.32	-	-	97.43	27.43	16.67	33.21	100	222	A	H
		2484.81	55.17	-18.83	74	44.4	27.33	16.71	33.27	100	222	P	H
		2487.12	44.69	-9.31	54	33.92	27.33	16.71	33.27	100	222	A	H
		2373.56	56.72	-17.28	74	45.7	27.55	16.61	33.14	248	268	P	V
		2388.4	45.09	-8.91	54	34.1	27.52	16.63	33.16	248	268	A	V
	*	2437	114.05	-	-	103.16	27.43	16.67	33.21	248	268	P	V
	*	2437	110.89	-	-	100	27.43	16.67	33.21	248	268	A	V
		2484.95	56.07	-17.93	74	45.3	27.33	16.71	33.27	248	268	P	V
		2487.26	45.62	-8.38	54	34.85	27.33	16.71	33.27	248	268	A	V
802.11b CH 11 2462MHz	*	2462	112.19	-	-	101.36	27.38	16.69	33.24	136	238	P	H
	*	2462	109.27	-	-	98.44	27.38	16.69	33.24	136	238	A	H
		2488.72	57.19	-16.81	74	46.43	27.32	16.72	33.28	136	238	P	H
		2488.44	47.28	-6.72	54	36.52	27.32	16.72	33.28	136	238	A	H
													H
													H
	*	2462	114.1	-	-	103.27	27.38	16.69	33.24	300	100	P	V
	*	2462	110.99	-	-	100.16	27.38	16.69	33.24	300	100	A	V
		2485.32	57.6	-16.4	74	46.83	27.33	16.71	33.27	300	100	P	V
		2487.88	47.43	-6.57	54	36.68	27.32	16.71	33.28	300	100	A	V
												V	
												V	
Remark	1. No other spurious found. 2. All results are PASS against Peak and Average limit line.												



**2.4GHz 2400~2483.5MHz
WIFI 802.11b (Harmonic @ 3m)**

WIFI Ant. 1+2	Note	Frequency (MHz)	Level (dBµV/m)	Over Limit (dB)	Limit Line (dBµV/m)	Read Level (dBµV)	Antenna Factor (dB/m)	Path Loss (dB)	Preamp Factor (dB)	Ant Pos (cm)	Table Pos (deg)	Peak Avg. (P/A)	Pol. (H/V)	
802.11b CH 01 2412MHz		4824	38.44	-35.56	74	56.04	31.1	10.46	59.16	100	0	P	H	
													H	
													H	
													H	
			4824	41.16	-32.84	74	58.76	31.1	10.46	59.16	100	0	P	V
														V
														V
802.11b CH 06 2437MHz		4874	39.41	-34.59	74	57.04	31.1	10.44	59.17	100	0	P	H	
		7311	42.09	-31.91	74	51.73	36.58	12.96	59.18	100	0	P	H	
													H	
													H	
			4874	42.37	-31.63	74	60	31.1	10.44	59.17	100	0	P	V
			7311	42.03	-31.97	74	51.67	36.58	12.96	59.18	100	0	P	V
														V
802.11b CH 11 2462MHz		4924	40	-34	74	57.56	31.2	10.42	59.18	100	0	P	H	
		7386	41.09	-32.91	74	50.9	36.36	12.98	59.15	100	0	P	H	
													H	
													H	
			4924	43.65	-30.35	74	61.21	31.2	10.42	59.18	100	0	P	V
			7386	41.61	-32.39	74	51.42	36.36	12.98	59.15	100	0	P	V
														V
Remark	1. No other spurious found.													
	2. All results are PASS against Peak and Average limit line.													



**2.4GHz 2400~2483.5MHz
WIFI 802.11g (Band Edge @ 3m)**

WIFI Ant. 1+2	Note	Frequency (MHz)	Level (dBμV/m)	Over Limit (dB)	Limit Line (dBμV/m)	Read Level (dBμV)	Antenna Factor (dB/m)	Path Loss (dB)	Preamp Factor (dB)	Ant Pos (cm)	Table Pos (deg)	Peak Avg. (P/A)	Pol. (H/V)	
802.11g CH 01 2412MHz		2389.485	62.03	-11.97	74	51.04	27.52	16.63	33.16	107	221	P	H	
		2389.8	51.03	-2.97	54	40.04	27.52	16.63	33.16	107	221	A	H	
	*	2412	110.31	-	-	99.36	27.48	16.65	33.18	107	221	P	H	
	*	2412	102.71	-	-	91.76	27.48	16.65	33.18	107	221	A	H	
													H	
														H
			2390	61.25	-12.75	74	50.26	27.52	16.63	33.16	285	277	P	V
			2390	52.67	-1.33	54	41.68	27.52	16.63	33.16	285	277	A	V
	*		2412	112.14	-	-	101.19	27.48	16.65	33.18	285	277	P	V
	*		2412	104.53	-	-	93.58	27.48	16.65	33.18	285	277	A	V
														V
														V
802.11g CH 06 2437MHz		2384.9	56.24	-17.76	74	45.24	27.53	16.62	33.15	120	228	P	H	
		2389.52	47.11	-6.89	54	36.12	27.52	16.63	33.16	120	228	A	H	
	*	2437	111.26	-	-	100.37	27.43	16.67	33.21	120	228	P	H	
	*	2437	104.06	-	-	93.17	27.43	16.67	33.21	120	228	A	H	
			2490.76	56.19	-17.81	74	45.43	27.32	16.72	33.28	120	228	P	H
			2485.02	46.77	-7.23	54	36	27.33	16.71	33.27	120	228	A	H
			2385.18	57.29	-16.71	74	46.29	27.53	16.62	33.15	249	277	P	V
			2389.8	48.17	-5.83	54	37.18	27.52	16.63	33.16	249	277	A	V
	*		2437	113.46	-	-	102.57	27.43	16.67	33.21	249	277	P	V
	*		2437	106.14	-	-	95.25	27.43	16.67	33.21	249	277	A	V
			2489.64	57.72	-16.28	74	46.96	27.32	16.72	33.28	249	277	P	V
			2485.93	48.86	-5.14	54	38.09	27.33	16.71	33.27	249	277	A	V



WIFI Ant. 1+2	Note	Frequency (MHz)	Level (dBμV/m)	Over Limit (dB)	Limit Line (dBμV/m)	Read Level (dBμV)	Antenna Factor (dB/m)	Path Loss (dB)	Preamp Factor (dB)	Ant Pos (cm)	Table Pos (deg)	Peak Avg. (P/A)	Pol. (H/V)
802.11g CH 11 2462MHz	*	2462	108.85	-	-	98.02	27.38	16.69	33.24	109	231	P	H
	*	2462	102.07	-	-	91.24	27.38	16.69	33.24	109	231	A	H
		2483.6	60.5	-13.5	74	49.73	27.33	16.71	33.27	109	231	P	H
		2483.64	49.94	-4.06	54	39.17	27.33	16.71	33.27	109	231	A	H
													H
													H
	*	2462	111.85	-	-	101.04	27.37	16.69	33.25	253	272	P	V
	*	2462	104.36	-	-	93.55	27.37	16.69	33.25	253	272	A	V
		2484.32	62.22	-11.78	74	51.45	27.33	16.71	33.27	253	272	P	V
		2483.6	52	-2	54	41.23	27.33	16.71	33.27	253	272	A	V
													V
													V
	Remark	1. No other spurious found. 2. All results are PASS against Peak and Average limit line.											



**2.4GHz 2400~2483.5MHz
WIFI 802.11g (Harmonic @ 3m)**

WIFI Ant. 1+2	Note	Frequency (MHz)	Level (dBµV/m)	Over Limit (dB)	Limit Line (dBµV/m)	Read Level (dBµV)	Antenna Factor (dB/m)	Path Loss (dB)	Preamp Factor (dB)	Ant Pos (cm)	Table Pos (deg)	Peak Avg. (P/A)	Pol. (H/V)	
802.11g CH 01 2412MHz		4824	35.53	-38.47	74	53.13	31.1	10.46	59.16	100	0	P	H	
													H	
													H	
													H	
			4824	35.36	-38.64	74	52.96	31.1	10.46	59.16	100	0	P	V
														V
														V
802.11g CH 06 2437MHz		4874	36.61	-37.39	74	54.24	31.1	10.44	59.17	100	0	P	H	
		7311	42.98	-31.02	74	52.62	36.58	12.96	59.18	100	0	P	H	
													H	
													H	
			4874	36.53	-37.47	74	54.16	31.1	10.44	59.17	100	0	P	V
			7311	43.02	-30.98	74	52.66	36.58	12.96	59.18	100	0	P	V
														V
802.11g CH 11 2462MHz		4924	35.55	-38.45	74	53.11	31.2	10.42	59.18	100	0	P	H	
		7386	41.68	-32.32	74	51.49	36.36	12.98	59.15	100	0	P	H	
													H	
													H	
			4924	35.98	-38.02	74	53.54	31.2	10.42	59.18	100	0	P	V
			7386	41.4	-32.6	74	51.21	36.36	12.98	59.15	100	0	P	V
														V
Remark	1. No other spurious found.													
	2. All results are PASS against Peak and Average limit line.													



**2.4GHz 2400~2483.5MHz
WIFI 802.11ac VHT20 (Band Edge @ 3m)**

WIFI Ant. 1+2	Note	Frequency (MHz)	Level (dBµV/m)	Over Limit (dB)	Limit Line (dBµV/m)	Read Level (dBµV)	Antenna Factor (dB/m)	Path Loss (dB)	Preamp Factor (dB)	Ant Pos (cm)	Table Pos (deg)	Peak Avg. (P/A)	Pol. (H/V)	
802.11ac VHT20 CH 01 2412MHz		2389.8	59.09	-14.91	74	48.1	27.52	16.63	33.16	100	307	P	H	
		2390	49.07	-4.93	54	38.08	27.52	16.63	33.16	100	307	A	H	
	*	2412	109.8	-	-	98.85	27.48	16.65	33.18	100	307	P	H	
	*	2412	102.02	-	-	91.07	27.48	16.65	33.18	100	307	A	H	
													H	
														H
			2388.33	62.67	-11.33	74	51.68	27.52	16.63	33.16	286	278	P	V
			2390	52.03	-1.97	54	41.04	27.52	16.63	33.16	286	278	A	V
		*	2412	111.67	-	-	100.72	27.48	16.65	33.18	286	278	P	V
		*	2412	103.95	-	-	93	27.48	16.65	33.18	286	278	A	V
													V	
													V	
802.11ac VHT20 CH 06 2437MHz		2388.54	56.14	-17.86	74	45.15	27.52	16.63	33.16	100	46	P	H	
		2389.52	45.79	-8.21	54	34.8	27.52	16.63	33.16	100	46	A	H	
	*	2437	111.18	-	-	100.29	27.43	16.67	33.21	100	46	P	H	
	*	2437	103.94	-	-	93.05	27.43	16.67	33.21	100	46	A	H	
			2484.6	55.26	-18.74	74	44.49	27.33	16.71	33.27	100	46	P	H
			2488.31	45	-9	54	34.24	27.32	16.72	33.28	100	46	A	H
			2384.2	56.6	-17.4	74	45.6	27.53	16.62	33.15	209	0	P	V
			2389.38	46.12	-7.88	54	35.13	27.52	16.63	33.16	209	0	A	V
		*	2437	112.43	-	-	101.54	27.43	16.67	33.21	209	0	P	V
		*	2437	104.38	-	-	93.49	27.43	16.67	33.21	209	0	A	V
		2483.55	55.49	-18.51	74	44.72	27.33	16.71	33.27	209	0	P	V	
		2484.32	45.33	-8.67	54	34.56	27.33	16.71	33.27	209	0	A	V	



WIFI Ant. 1+2	Note	Frequency (MHz)	Level (dBμV/m)	Over Limit (dB)	Limit Line (dBμV/m)	Read Level (dBμV)	Antenna Factor (dB/m)	Path Loss (dB)	Preamp Factor (dB)	Ant Pos (cm)	Table Pos (deg)	Peak Avg. (P/A)	Pol. (H/V)	
802.11ac VHT20 CH 11 2462MHz	*	2462	109.99	-	-	99.16	27.38	16.69	33.24	100	225	P	H	
	*	2462	101.68	-	-	90.85	27.38	16.69	33.24	100	225	A	H	
		2484.08	59.65	-14.35	74	48.88	27.33	16.71	33.27	100	225	P	H	
		2483.52	49.99	-4.01	54	39.22	27.33	16.71	33.27	100	225	A	H	
													H	
														H
	*	2462	113.03	-	-	102.2	27.38	16.69	33.24	222	278	P	V	
	*	2462	104.83	-	-	94	27.38	16.69	33.24	222	278	A	V	
		2485.64	63.16	-10.84	74	52.39	27.33	16.71	33.27	222	278	P	V	
		2483.52	52.93	-1.07	54	42.16	27.33	16.71	33.27	222	278	A	V	
													V	
													V	
Remark	1. No other spurious found. 2. All results are PASS against Peak and Average limit line.													



**2.4GHz 2400~2483.5MHz
WIFI 802.11ac VHT20 (Harmonic @ 3m)**

WIFI Ant. 1+2	Note	Frequency (MHz)	Level (dBμV/m)	Over Limit (dB)	Limit Line (dBμV/m)	Read Level (dBμV)	Antenna Factor (dB/m)	Path Loss (dB)	Preamp Factor (dB)	Ant Pos (cm)	Table Pos (deg)	Peak Avg. (P/A)	Pol. (H/V)	
802.11ac VHT20 CH 01 2412MHz		4824	35.49	-38.51	74	53.09	31.1	10.46	59.16	100	0	P	H	
													H	
													H	
													H	
			4824	35.99	-38.01	74	53.59	31.1	10.46	59.16	100	0	P	V
														V
														V
802.11ac VHT20 CH 06 2437MHz		4874	36.47	-37.53	74	54.1	31.1	10.44	59.17	100	0	P	H	
		7311	47.3	-26.7	74	56.94	36.58	12.96	59.18	100	0	P	H	
													H	
													H	
			4874	36.71	-37.29	74	54.34	31.1	10.44	59.17	100	0	P	V
			7311	48.01	-25.99	74	57.65	36.58	12.96	59.18	100	0	P	V
														V
802.11ac VHT20 CH 11 2462MHz		4924	35.94	-38.06	74	53.5	31.2	10.42	59.18	100	0	P	H	
		7386	43.5	-30.5	74	53.31	36.36	12.98	59.15	100	0	P	H	
													H	
													H	
			4924	36.92	-37.08	74	54.48	31.2	10.42	59.18	100	0	P	V
			7386	46.77	-27.23	74	56.58	36.36	12.98	59.15	100	0	P	V
														V
Remark	1. No other spurious found.													
	2. All results are PASS against Peak and Average limit line.													



Emission below 1GHz

2.4GHz WIFI 802.11ac VHT20 (LF)

WIFI	Note	Frequency	Level	Over	Limit	Read	Antenna	Path	Preamp	Ant	Table	Peak	Pol.	
Ant.				Limit	Line	Level	Factor	Loss	Factor	Pos	Pos	Avg.		
1+2		(MHz)	(dBµV/m)	(dB)	(dBµV/m)	(dBµV)	(dB/m)	(dB)	(dB)	(cm)	(deg)	(P/A)	(H/V)	
2.4GHz 802.11ac VHT20 LF		30	24.39	-15.61	40	29.63	24.17	0.77	30.18	-	-	P	H	
		110.51	27.55	-15.95	43.5	39.62	16.88	1.47	30.42	-	-	P	H	
		220.12	31.41	-14.59	46	44.49	15.16	2.04	30.28	-	-	P	H	
		806.97	33.51	-12.49	46	30.7	28.09	4	29.28	-	-	P	H	
		865.17	34.96	-11.04	46	30.76	29.24	4.15	29.19	-	-	P	H	
		956.35	36.38	-9.62	46	30.15	30.75	4.46	28.98	100	0	P	H	
													H	
													H	
													H	
													H	
													H	
													H	
													V	
			32.91	28.97	-11.03	40	35.5	22.89	0.81	30.23	-	-	P	V
			173.56	28.46	-15.04	43.5	41.48	15.42	1.91	30.35	-	-	P	V
			216.24	26.7	-19.3	46	39.83	15.13	2.03	30.29	-	-	P	V
			778.84	33.02	-12.98	46	30.3	28.14	3.92	29.34	-	-	P	V
			895.24	34.71	-11.29	46	30.59	29.02	4.25	29.15	-	-	P	V
			955.38	35.89	-10.11	46	29.7	30.71	4.46	28.98	100	0	P	V
													V	
												V		
												V		
												V		
												V		
												V		
Remark	1. No other spurious found. 2. All results are PASS against limit line.													



Note symbol

*	Fundamental Frequency which can be ignored. However, the level of any unwanted emissions shall not exceed the level of the fundamental frequency.
!	Test result is over limit line.
P/A	Peak or Average
H/V	Horizontal or Vertical



A calculation example for radiated spurious emission is shown as below:

WIFI	Note	Frequency	Level	Over	Limit	Read	Antenna	Path	Preamp	Ant	Table	Peak	Pol.
Ant.				Limit	Line	Level	Factor	Loss	Factor	Pos	Pos	Avg.	
1+2		(MHz)	(dBμV/m)	(dB)	(dBμV/m)	(dBμV)	(dB/m)	(dB)	(dB)	(cm)	(deg)	(P/A)	(H/V)
802.11b		2390	55.45	-18.55	74	54.51	32.22	4.58	35.86	103	308	P	H
CH 01													
2412MHz		2390	43.54	-10.46	54	42.6	32.22	4.58	35.86	103	308	A	H

1. Path Loss(dB) = Cable loss(dB) + Filter loss(dB) + Attenuator loss(dB)
2. Level(dBμV/m) =
Antenna Factor(dB/m) + Path Loss(dB) + Read Level(dBμV) - Preamp Factor(dB)
3. Over Limit(dB) = Level(dBμV/m) – Limit Line(dBμV/m)

For Peak Limit @ 2390MHz:

1. Level(dBμV/m)
= Antenna Factor(dB/m) + Path Loss(dB) + Read Level(dBμV) - Preamp Factor(dB)
= 32.22(dB/m) + 4.58(dB) + 54.51(dBμV) – 35.86 (dB)
= 55.45 (dBμV/m)
2. Over Limit(dB)
= Level(dBμV/m) – Limit Line(dBμV/m)
= 55.45(dBμV/m) – 74(dBμV/m)
= -18.55(dB)

For Average Limit @ 2390MHz:

1. Level(dBμV/m)
= Antenna Factor(dB/m) + Path Loss(dB) + Read Level(dBμV) - Preamp Factor(dB)
= 32.22(dB/m) + 4.58(dB) + 42.6(dBμV) – 35.86 (dB)
= 43.54 (dBμV/m)
2. Over Limit(dB)
= Level(dBμV/m) – Limit Line(dBμV/m)
= 43.54(dBμV/m) – 54(dBμV/m)
= -10.46(dB)

Both peak and average measured complies with the limit line, so test result is “PASS”.



Appendix D. Radiated Spurious Emission Plots

Test Engineer :	Jack Cheng, Lance Chiang, Chuan Chu	Temperature :	21~24°C
		Relative Humidity :	56~68%

Note symbol

-L	Low channel location
-R	High channel location



2.4GHz 2400~2483.5MHz

WIFI 802.11b (Band Edge @ 3m)

WIFI	2.4GHz 2400~2483.5MHz Band Edge @ 3m	
ANT	802.11b CH01 2412MHz	
1+2	Horizontal	Fundamental
Peak	<p>Site : 03CH12-HY Condition : PEAK_BE_74 3m HORN_9120D_1328 HORIZONTAL RBW:1000.000kHz VBW:3000.000kHz SWT:Auto Detector : Peak Project : 952409 Mode : 12 Setting : 18</p>	<p>Site : 03CH12-HY Condition : PEAK_FA_3m HORN_9120D_1328 HORIZONTAL RBW:1000.000kHz VBW:3000.000kHz SWT:Auto Detector : Peak Project : 952409 Mode : 12 Setting : 18</p>
Avg.	<p>Site : 03CH12-HY Condition : AVG_BE_54 3m HORN_9120D_1328 HORIZONTAL RBW:1000.000kHz VBW:0.010kHz SWT:Auto Detector : Peak Project : 952409 Mode : 12 Setting : 18</p>	<p>Site : 03CH12-HY Condition : AVG_FA_3m HORN_9120D_1328 HORIZONTAL RBW:1000.000kHz VBW:0.010kHz SWT:Auto Detector : Peak Project : 952409 Mode : 12 Setting : 18</p>

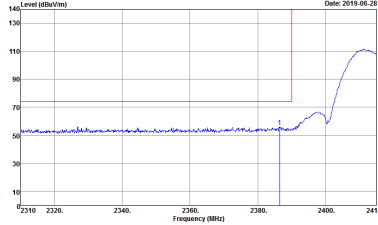
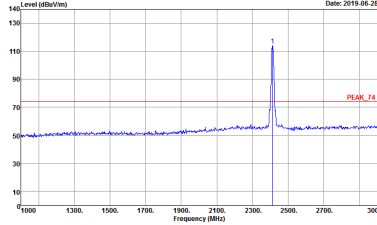
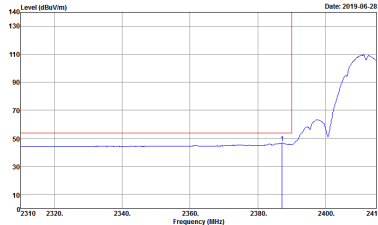
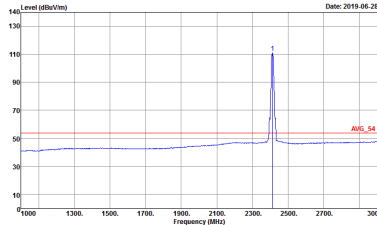

WIFI	2.4GHz 2400~2483.5MHz Band Edge @ 3m	
ANT	802.11b CH01 2412MHz	
1+2	Vertical	Fundamental
Peak	 <p>Site : 03CH12-HY Condition : PEAK_9C_74 3m HORN_91200_1328 VERTICAL RBW:3000.000KHz VBW:3000.000KHz SWT:Auto Detector : Peak Project : 952409 Mode : 12 Setting : 18</p>	 <p>Site : 03CH12-HY Condition : PEAK_74 3m HORN_91200_1328 VERTICAL RBW:3000.000KHz VBW:3000.000KHz SWT:Auto Detector : Peak Project : 952409 Mode : 12 Setting : 18</p>
Avg.	 <p>Site : 03CH12-HY Condition : AVG_BE_54 3m HORN_91200_1328 VERTICAL RBW:3000.000KHz VBW:0.010KHz SWT:Auto Detector : Peak Project : 952409 Mode : 12 Setting : 18</p>	 <p>Site : 03CH12-HY Condition : AVG_54 3m HORN_91200_1328 VERTICAL RBW:3000.000KHz VBW:0.010KHz SWT:Auto Detector : Peak Project : 952409 Mode : 12 Setting : 18</p>

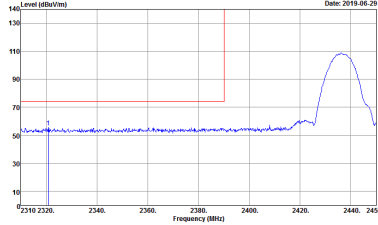
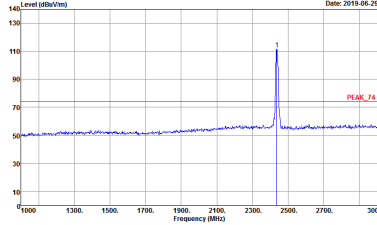
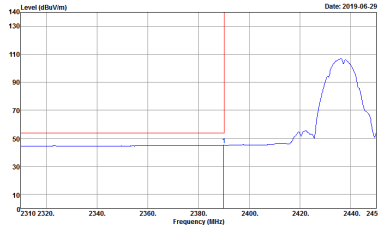
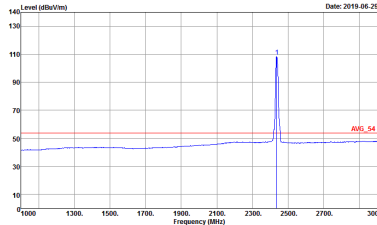

WIFI	2.4GHz 2400~2483.5MHz Band Edge @ 3m	
ANT	802.11b CH06 2437MHz - L	
1+2	Horizontal	Fundamental
Peak	 <p>Site : 03CH12-HY Condition : PEAK_9C_74 3m HORN_9120D_1328 HORIZONTAL RBW:1000.000KHz VBW:3000.000KHz SWT:Auto Detector : Peak Project : 952409 Mode : 13 Setting : 18</p>	 <p>Site : 03CH12-HY Condition : PEAK_74 3m HORN_9120D_1328 HORIZONTAL RBW:1000.000KHz VBW:3000.000KHz SWT:Auto Detector : Peak Project : 952409 Mode : 13 Setting : 18</p>
Avg.	 <p>Site : 03CH12-HY Condition : AVG_9C_74 3m HORN_9120D_1328 HORIZONTAL RBW:1000.000KHz VBW:10.000KHz SWT:Auto Detector : Peak Project : 952409 Mode : 13 Setting : 18</p>	 <p>Site : 03CH12-HY Condition : AVG_74 3m HORN_9120D_1328 HORIZONTAL RBW:1000.000KHz VBW:10.000KHz SWT:Auto Detector : Peak Project : 952409 Mode : 13 Setting : 18</p>

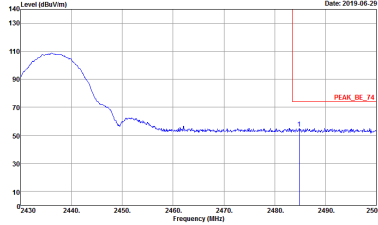
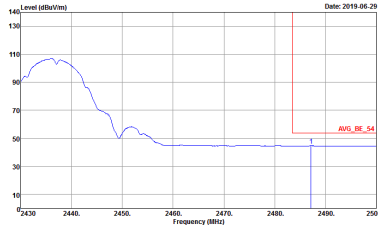

WIFI	2.4GHz 2400~2483.5MHz Band Edge @ 3m	
ANT	802.11b CH06 2437MHz - R	
1+2	Horizontal	Fundamental
<p>Peak</p>	 <p>Site : 03CH2-HY Condition : PEAK_BE_74 3m HORN_9120D_1328 HORIZONTAL Detector : Peak Project : 952409 Mode : 13 Setting : 18</p>	<p>Left blank</p>
<p>Avg.</p>	 <p>Site : 03CH2-HY Condition : AVG_BE_54 3m HORN_9120D_1328 HORIZONTAL Detector : Peak Project : 952409 Mode : 13 Setting : 18</p>	<p>Left blank</p>

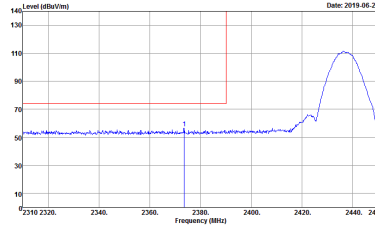
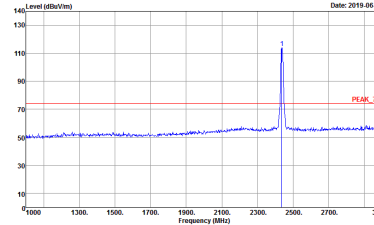
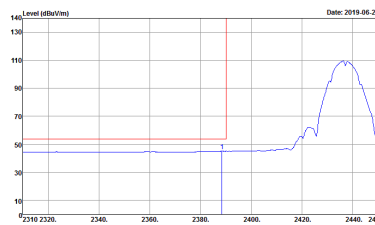
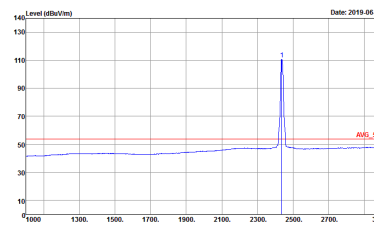

WIFI	2.4GHz 2400~2483.5MHz Band Edge @ 3m	
ANT	802.11b CH06 2437MHz - L	
1+2	Vertical	Fundamental
Peak	 <p>Site : 03CH12-HY Condition : PEAK_BE_74 3m HORN_91200_1328 VERTICAL RBW:3000.000KHz VBW:3000.000KHz SWT:Auto Detector : Peak Project : 952409 Mode : 13 Setting : 18</p>	 <p>Site : 03CH12-HY Condition : PEAK_F4 3m HORN_91200_1328 VERTICAL RBW:3000.000KHz VBW:3000.000KHz SWT:Auto Detector : Peak Project : 952409 Mode : 13 Setting : 18</p>
Avg.	 <p>Site : 03CH12-HY Condition : AVG_BE_54 3m HORN_91200_1328 VERTICAL RBW:3000.000KHz VBW:0.010KHz SWT:Auto Detector : Peak Project : 952409 Mode : 13 Setting : 18</p>	 <p>Site : 03CH12-HY Condition : AVG_F4 3m HORN_91200_1328 VERTICAL RBW:3000.000KHz VBW:0.010KHz SWT:Auto Detector : Peak Project : 952409 Mode : 13 Setting : 18</p>

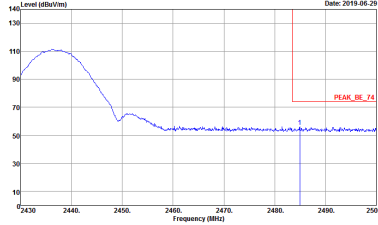
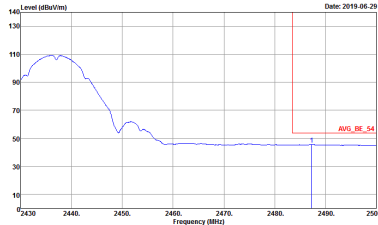

WIFI	2.4GHz 2400~2483.5MHz Band Edge @ 3m	
ANT	802.11b CH06 2437MHz - R	
1+2	Vertical	Fundamental
<p>Peak</p>	 <p>Site : 03CH2-HY Condition : PEAK_BE_74 3m HORN_9120D_1328 VERTICAL RBW:10000000Hz VBW:3000.0000Hz SWT:Auto Detector : Peak Project : 952409 Mode : 13 Setting : 18</p>	<p>Left blank</p>
<p>Avg.</p>	 <p>Site : 03CH2-HY Condition : AVG_BE_54 3m HORN_9120D_1328 VERTICAL RBW:10000000Hz VBW:10.0000Hz SWT:Auto Detector : Peak Project : 952409 Mode : 13 Setting : 18</p>	<p>Left blank</p>

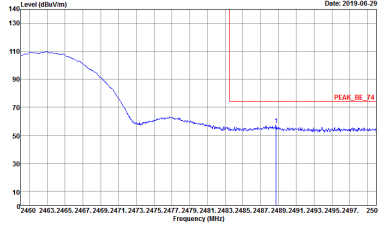
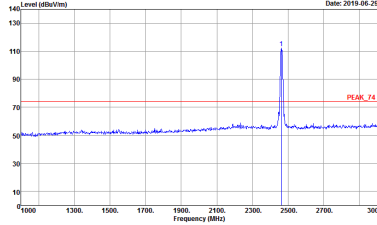
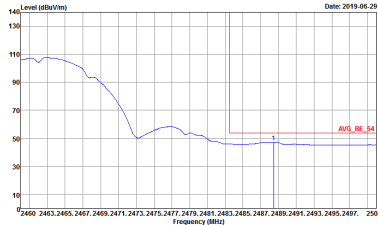
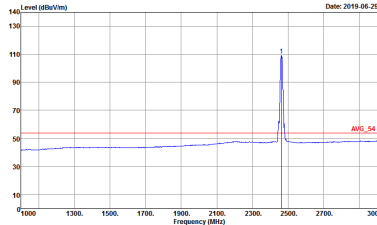

WIFI	2.4GHz 2400~2483.5MHz Band Edge @ 3m	
ANT	802.11b CH11 2462MHz	
1+2	Horizontal	Fundamental
<p>Peak</p>	 <p>Site : 03CH12-HY Condition : PEAK_BE_74 3m HORN_91200_1328 HORIZONTAL RBW:3000.000KHz VBW:3000.000KHz SWT:Auto Detector : Peak Project : 952409 Mode : 14 Setting : 18</p>	 <p>Site : 03CH12-HY Condition : PEAK_F4 3m HORN_91200_1328 HORIZONTAL RBW:3000.000KHz VBW:3000.000KHz SWT:Auto Detector : Peak Project : 952409 Mode : 14 Setting : 18</p>
<p>Avg.</p>	 <p>Site : 03CH12-HY Condition : AVG_BE_54 3m HORN_91200_1328 HORIZONTAL RBW:3000.000KHz VBW:0.030KHz SWT:Auto Detector : Peak Project : 952409 Mode : 14 Setting : 18</p>	 <p>Site : 03CH12-HY Condition : AVG_F4 3m HORN_91200_1328 HORIZONTAL RBW:3000.000KHz VBW:0.030KHz SWT:Auto Detector : Peak Project : 952409 Mode : 14 Setting : 18</p>

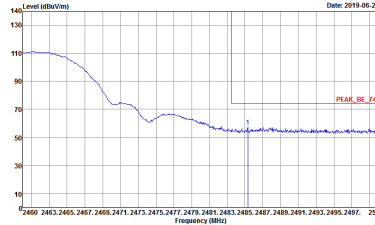
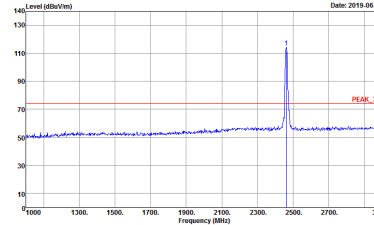
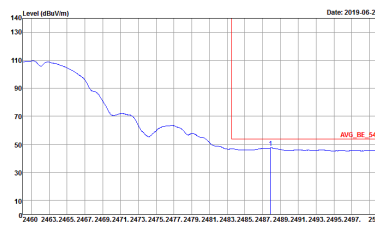
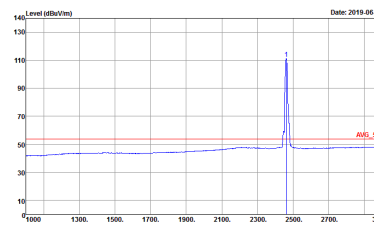

WIFI	2.4GHz 2400~2483.5MHz Band Edge @ 3m	
ANT	802.11b CH11 2462MHz	
1+2	Vertical	Fundamental
Peak	 <p>Site : 03CH12-HY Condition : PEAK_BE_74 3m HORN_91200_1328 VERTICAL RBW:3000.000kHz VBW:3000.000kHz SWT:Auto Detector : Peak Project : 952409 Mode : 14 Setting : 18</p>	 <p>Site : 03CH12-HY Condition : PEAK_74 3m HORN_91200_1328 VERTICAL RBW:3000.000kHz VBW:3000.000kHz SWT:Auto Detector : Peak Project : 952409 Mode : 14 Setting : 18</p>
Avg.	 <p>Site : 03CH12-HY Condition : AVG_BE_54 3m HORN_91200_1328 VERTICAL RBW:3000.000kHz VBW:0.010kHz SWT:Auto Detector : Peak Project : 952409 Mode : 14 Setting : 18</p>	 <p>Site : 03CH12-HY Condition : AVG_54 3m HORN_91200_1328 VERTICAL RBW:3000.000kHz VBW:0.010kHz SWT:Auto Detector : Peak Project : 952409 Mode : 14 Setting : 18</p>



2.4GHz 2400~2483.5MHz

WIFI 802.11g (Band Edge @ 3m)

WIFI	2.4GHz 2400~2483.5MHz Band Edge @ 3m	
ANT	802.11g CH01 2412MHz	
1+2	Horizontal	Fundamental
Peak	<p>Site : 03CH12-HY Condition : PEAK_BE_74 3m HORN_9120D_1328 HORIZONTAL RBW:1000.000kHz VBW:3000.000kHz SWT:Auto Detector : Peak Project : 952409 Mode : 15 Setting : 15.5</p>	<p>Site : 03CH12-HY Condition : PEAK_FA_3m HORN_9120D_1328 HORIZONTAL RBW:1000.000kHz VBW:3000.000kHz SWT:Auto Detector : Peak Project : 952409 Mode : 15 Setting : 15.5</p>
Avg.	<p>Site : 03CH12-HY Condition : AVG_BE_54 3m HORN_9120D_1328 HORIZONTAL RBW:1000.000kHz VBW:1.000kHz SWT:Auto Detector : Peak Project : 952409 Mode : 15 Setting : 15.5</p>	<p>Site : 03CH12-HY Condition : AVG_FA_3m HORN_9120D_1328 HORIZONTAL RBW:1000.000kHz VBW:1.000kHz SWT:Auto Detector : Peak Project : 952409 Mode : 15 Setting : 15.5</p>

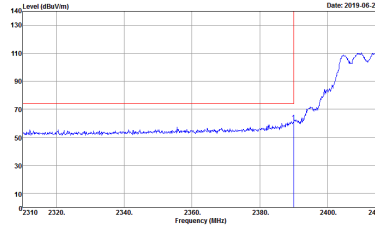
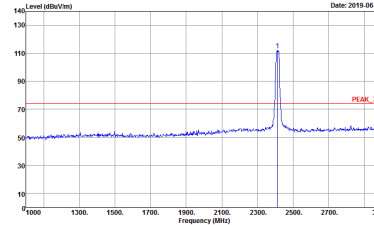
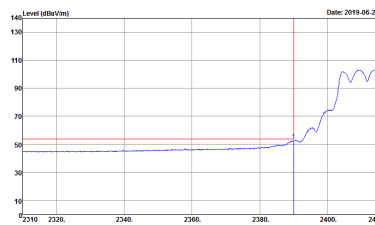
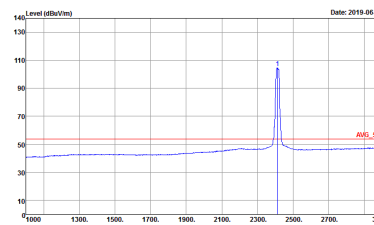

WIFI	2.4GHz 2400~2483.5MHz Band Edge @ 3m	
ANT	802.11g CH01 2412MHz	
1+2	Vertical	Fundamental
Peak	 <p>Site : 03CH12-11Y Condition : PEAK_BE_74 3m HORN_9120D_1328 VERTICAL RBW:3000.000KHz VBW:3000.000KHz SWT:Auto Detector : Peak Project : 952409 Mode : 15 Setting : 15.5</p>	 <p>Site : 03CH12-11Y Condition : PEAK_F4 3m HORN_9120D_1328 VERTICAL RBW:3000.000KHz VBW:3000.000KHz SWT:Auto Detector : Peak Project : 952409 Mode : 15 Setting : 15.5</p>
Avg.	 <p>Site : 03CH12-11Y Condition : AVG_BE_54 3m HORN_9120D_1328 VERTICAL RBW:1000.000KHz VBW:1.000KHz SWT:Auto Detector : Peak Project : 952409 Mode : 15 Setting : 15.5</p>	 <p>Site : 03CH12-11Y Condition : AVG_F4 3m HORN_9120D_1328 VERTICAL RBW:1000.000KHz VBW:1.000KHz SWT:Auto Detector : Peak Project : 952409 Mode : 15 Setting : 15.5</p>

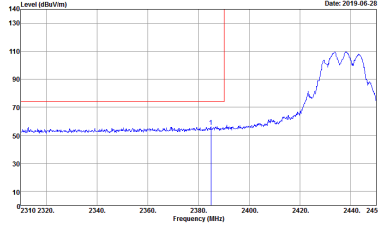
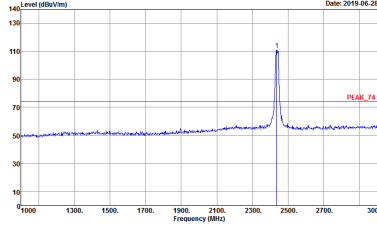
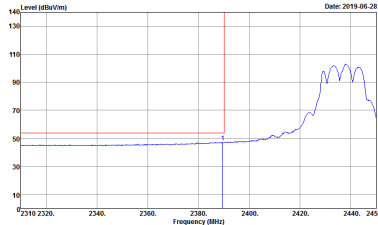
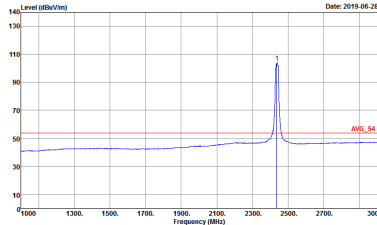

WIFI	2.4GHz 2400~2483.5MHz Band Edge @ 3m	
ANT	802.11g CH06 2437MHz - L	
1+2	Horizontal	Fundamental
<p>Peak</p>	 <p>Site : 03CH12-HY Condition : PEAK_9C_74 3m HORN_9120D_1328 HORIZONTAL Detector : Peak Project : 952409 Mode : 16 Setting : 17</p>	 <p>Site : 03CH12-HY Condition : PEAK_74 3m HORN_9120D_1328 HORIZONTAL Detector : Peak Project : 952409 Mode : 16 Setting : 17</p>
<p>Avg.</p>	 <p>Site : 03CH12-HY Condition : AVG_BE_54 3m HORN_9120D_1328 HORIZONTAL Detector : Peak Project : 952409 Mode : 16 Setting : 17</p>	 <p>Site : 03CH12-HY Condition : AVG_54 3m HORN_9120D_1328 HORIZONTAL Detector : Peak Project : 952409 Mode : 16 Setting : 17</p>

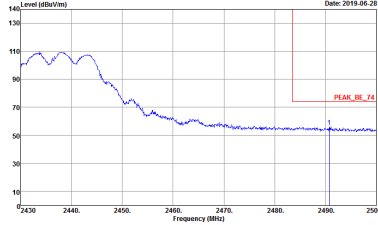
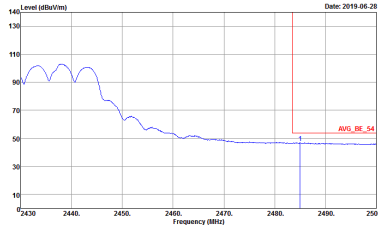

WIFI	2.4GHz 2400~2483.5MHz Band Edge @ 3m	
ANT	802.11g CH06 2437MHz - R	
1+2	Horizontal	Fundamental
<p>Peak</p>	 <p>Site : 03CH2-11Y Condition : PEAK_BE_74 3m HORN_9120D_1328 HORIZONTAL Detector : Peak Project : 952409 Mode : 16 Setting : 17</p>	<p>Left blank</p>
<p>Avg.</p>	 <p>Site : 03CH2-11Y Condition : AVG_BE_54 3m HORN_9120D_1328 HORIZONTAL Detector : Peak Project : 952409 Mode : 16 Setting : 17</p>	<p>Left blank</p>

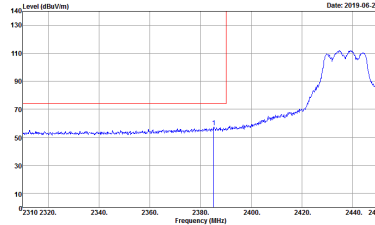
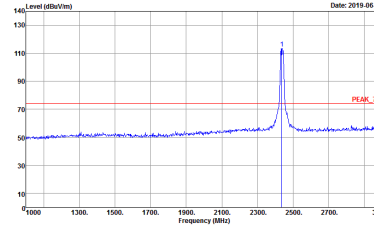
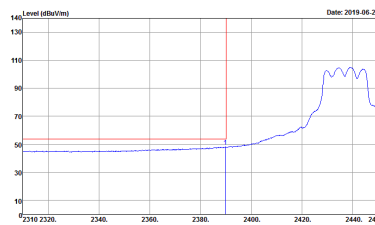
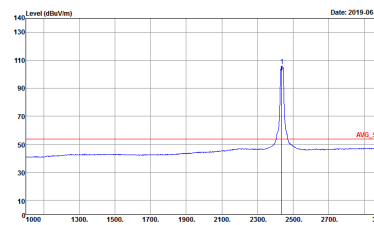

WIFI	2.4GHz 2400~2483.5MHz Band Edge @ 3m	
ANT	802.11g CH06 2437MHz - L	
1+2	Vertical	Fundamental
Peak	 <p>Site : 03CH12-HY Condition : PEAK_9C_74 3m HORN_9120D_1328 VERTICAL RBW:3000.000KHz VBW:3000.000KHz SWT:Auto Detector : Peak Project : 952409 Mode : 16 Setting : 17</p>	 <p>Site : 03CH12-HY Condition : PEAK_74 3m HORN_9120D_1328 VERTICAL RBW:3000.000KHz VBW:3000.000KHz SWT:Auto Detector : Peak Project : 952409 Mode : 16 Setting : 17</p>
Avg.	 <p>Site : 03CH12-HY Condition : AVG_BE_54 3m HORN_9120D_1328 VERTICAL RBW:1000.000KHz VBW:1.000KHz SWT:Auto Detector : Peak Project : 952409 Mode : 16 Setting : 17</p>	 <p>Site : 03CH12-HY Condition : AVG_54 3m HORN_9120D_1328 VERTICAL RBW:1000.000KHz VBW:1.000KHz SWT:Auto Detector : Peak Project : 952409 Mode : 16 Setting : 17</p>

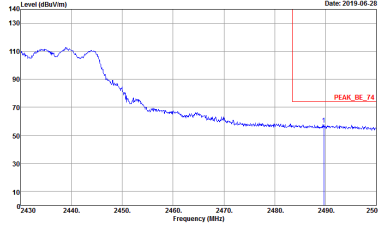
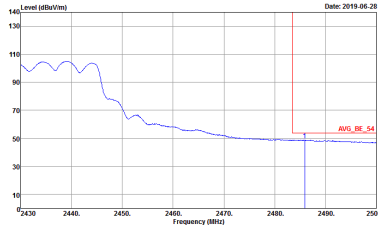

WIFI	2.4GHz 2400~2483.5MHz Band Edge @ 3m	
ANT	802.11g CH06 2437MHz - R	
1+2	Vertical	Fundamental
<p>Peak</p>	 <p>Site : 03CH2-HY Condition : PEAK_BE_74 3m HORN_9120D_1328 VERTICAL RBW:1000.000KHz VBW:3000.000KHz SWT:Auto Detector : Peak Project : 952409 Mode : 16 Setting : 17</p>	<p>Left Blank</p>
<p>Avg.</p>	 <p>Site : 03CH2-HY Condition : AVG_BE_54 3m HORN_9120D_1328 VERTICAL RBW:1000.000KHz VBW:1.000KHz SWT:Auto Detector : Peak Project : 952409 Mode : 16 Setting : 17</p>	<p>Left Blank</p>

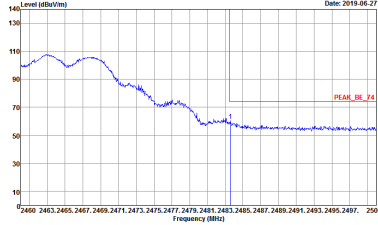
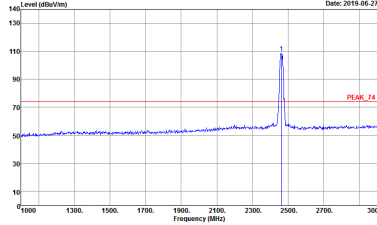
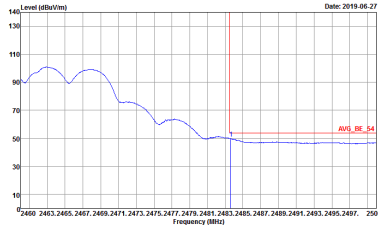
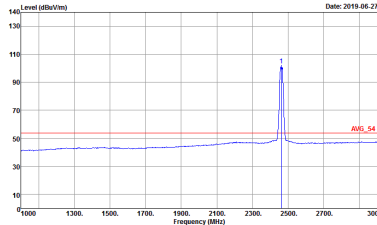

WIFI	2.4GHz 2400~2483.5MHz Band Edge @ 3m	
ANT	802.11g CH11 2462MHz	
1+2	Horizontal	Fundamental
<p>Peak</p>	 <p>Site : 03CH12-11Y Condition : PEAK_BE_74 3m HORN_9120D_1328 HORIZONTAL RBW:3000.000KHz VBW:3000.000KHz SWT:Auto Detector : Peak Project : 952409 Mode : 17 Setting : 14.5</p>	 <p>Site : 03CH12-11Y Condition : PEAK_74 3m HORN_9120D_1328 HORIZONTAL RBW:3000.000KHz VBW:3000.000KHz SWT:Auto Detector : Peak Project : 952409 Mode : 17 Setting : 14.5</p>
<p>Avg.</p>	 <p>Site : 03CH12-11Y Condition : AVG_BE_54 3m HORN_9120D_1328 HORIZONTAL RBW:1000.000KHz VBW:1.000KHz SWT:Auto Detector : Peak Project : 952409 Mode : 17 Setting : 14.5</p>	 <p>Site : 03CH12-11Y Condition : AVG_54 3m HORN_9120D_1328 HORIZONTAL RBW:1000.000KHz VBW:1.000KHz SWT:Auto Detector : Peak Project : 952409 Mode : 17 Setting : 14.5</p>

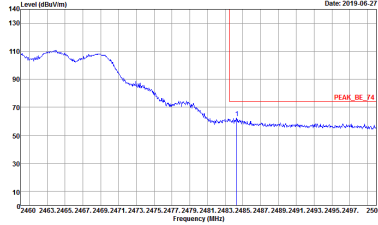
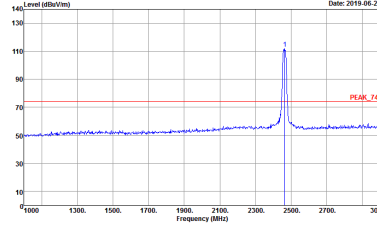
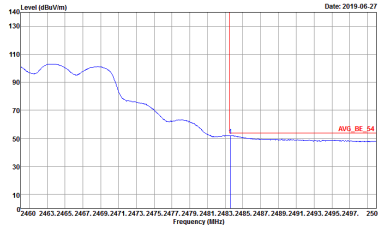
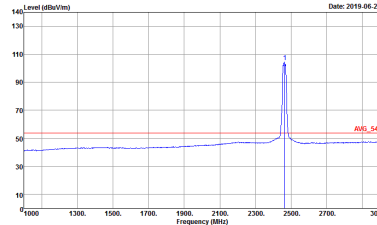

WIFI	2.4GHz 2400~2483.5MHz Band Edge @ 3m	
ANT	802.11g CH11 2462MHz	
1+2	Vertical	Fundamental
<p>Peak</p>	 <p>Site : 03CH12-HY Condition : PEAK_BE_74 3m HORN_9120D_1328 VERTICAL RBW:3000.000kHz VBW:3000.000kHz SWT:Auto Detector : Peak Project : 952409 Mode : 17 Setting : 14.5</p>	 <p>Site : 03CH12-HY Condition : PEAK_74 3m HORN_9120D_1328 VERTICAL RBW:3000.000kHz VBW:3000.000kHz SWT:Auto Detector : Peak Project : 952409 Mode : 17 Setting : 14.5</p>
<p>Avg.</p>	 <p>Site : 03CH12-HY Condition : AVG_BE_54 3m HORN_9120D_1328 VERTICAL RBW:3000.000kHz VBW:1.000kHz SWT:Auto Detector : Peak Project : 952409 Mode : 17 Setting : 14.5</p>	 <p>Site : 03CH12-HY Condition : AVG_54 3m HORN_9120D_1328 VERTICAL RBW:3000.000kHz VBW:1.000kHz SWT:Auto Detector : Peak Project : 952409 Mode : 17 Setting : 14.5</p>



2.4GHz 2400~2483.5MHz

WIFI 802.11ac VHT20 (Band Edge @ 3m)

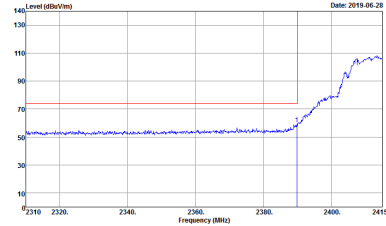
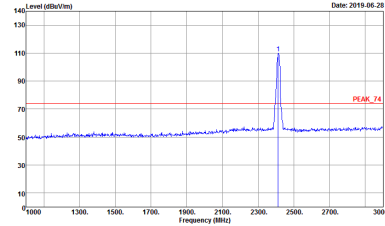
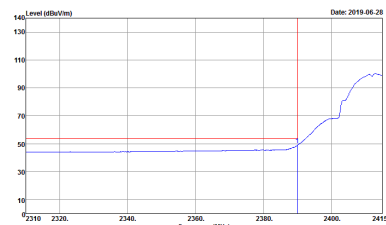
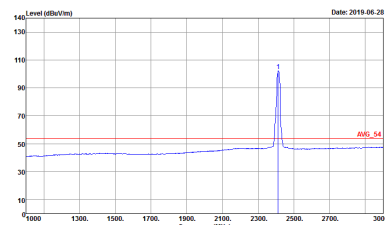
WIFI	2.4GHz 2400~2483.5MHz Band Edge @ 3m	
ANT	802.11ac VHT20 CH01 2412MHz	
1+2	Horizontal	Fundamental
Peak	 <p>Site : 03CH12-HY Condition : PEAK_BE_74 3m HORN_9120D_1328 HORIZONTAL RBW:1000.000kHz VBW:3000.000kHz SWT:Auto Detector : Peak Project : 952409 Mode : 18 Setting : 14.5</p>	 <p>Site : 03CH12-HY Condition : PEAK_74 3m HORN_9120D_1328 HORIZONTAL RBW:1000.000kHz VBW:3000.000kHz SWT:Auto Detector : Peak Project : 952409 Mode : 18 Setting : 14.5</p>
Avg.	 <p>Site : 03CH12-HY Condition : AV6_BE_54 3m HORN_9120D_1328 HORIZONTAL RBW:1000.000kHz VBW:1.000kHz SWT:Auto Detector : Peak Project : 952409 Mode : 18 Setting : 14.5</p>	 <p>Site : 03CH12-HY Condition : AV6_54 3m HORN_9120D_1328 HORIZONTAL RBW:1000.000kHz VBW:1.000kHz SWT:Auto Detector : Peak Project : 952409 Mode : 18 Setting : 14.5</p>

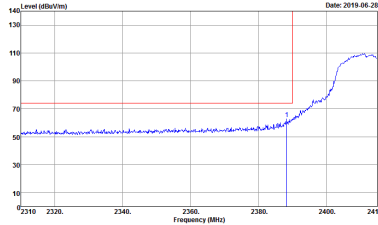
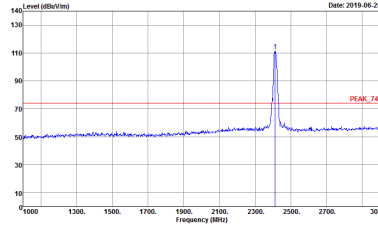
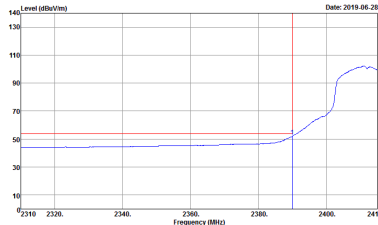
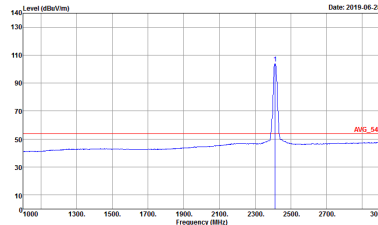

WIFI	2.4GHz 2400~2483.5MHz Band Edge @ 3m	
ANT	802.11ac VHT20 CH01 2412MHz	
1+2	Vertical	Fundamental
Peak	 <p>Site : 03CH12-HY Condition : PEAK_BE_74 3m HORN_9120D_1328 VERTICAL Detector : Peak Project : 952409 Mode : 1B Setting : 14.5</p>	 <p>Site : 03CH12-HY Condition : PEAK_74 3m HORN_9120D_1328 VERTICAL Detector : Peak Project : 952409 Mode : 1B Setting : 14.5</p>
Avg.	 <p>Site : 03CH12-HY Condition : AVG_BE_54 3m HORN_9120D_1328 VERTICAL Detector : Peak Project : 952409 Mode : 1B Setting : 14.5</p>	 <p>Site : 03CH12-HY Condition : AVG_54 3m HORN_9120D_1328 VERTICAL Detector : Peak Project : 952409 Mode : 1B Setting : 14.5</p>

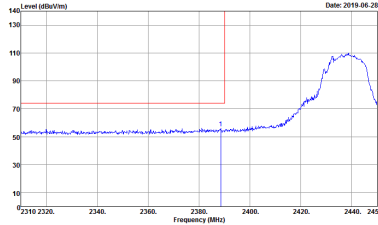
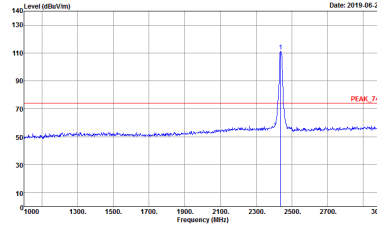
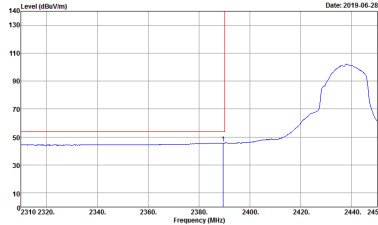
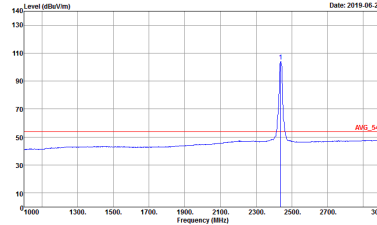

WIFI	2.4GHz 2400~2483.5MHz Band Edge @ 3m	
ANT	802.11ac VHT20 CH06 2437MHz - L	
1+2	Horizontal	Fundamental
Peak	 <p>Site : 03CH12-HY Condition : PEAK_BE_74 3m HORN_9120D_1328 HORIZONTAL Detector : Peak Project : 952409 Mode : 19 Setting : 17</p>	 <p>Site : 03CH12-HY Condition : PEAK_74 3m HORN_9120D_1328 HORIZONTAL Detector : Peak Project : 952409 Mode : 19 Setting : 17</p>
Avg.	 <p>Site : 03CH12-HY Condition : AVG_BE_54 3m HORN_9120D_1328 HORIZONTAL Detector : Peak Project : 952409 Mode : 19 Setting : 17</p>	 <p>Site : 03CH12-HY Condition : AVG_54 3m HORN_9120D_1328 HORIZONTAL Detector : Peak Project : 952409 Mode : 19 Setting : 17</p>

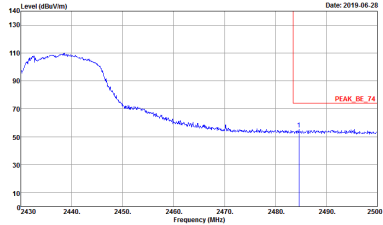
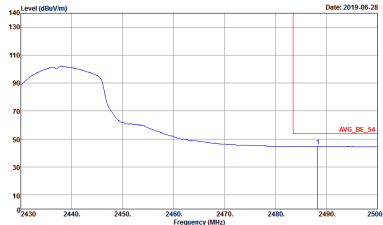

WIFI	2.4GHz 2400~2483.5MHz Band Edge @ 3m	
ANT	802.11ac VH20 CH06 2437MHz - R	
1+2	Horizontal	Fundamental
<p>Peak</p>	 <p>Site : 03CH12-HY Condition : PEAK_BE_74 3m HORN_91200_1328 HORIZONTAL Detector : Peak Project : 952409 Mode : 19 Setting : 17</p>	<p>Left blank</p>
<p>Avg.</p>	 <p>Site : 03CH12-HY Condition : AVG_BE_54 3m HORN_91200_1328 HORIZONTAL Detector : Peak Project : 952409 Mode : 19 Setting : 17</p>	<p>Left blank</p>

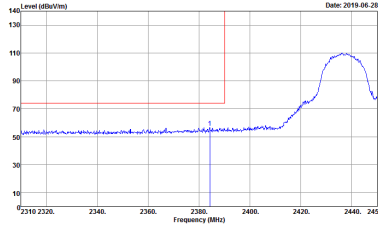
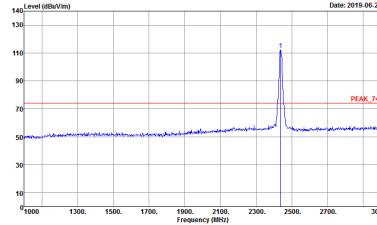
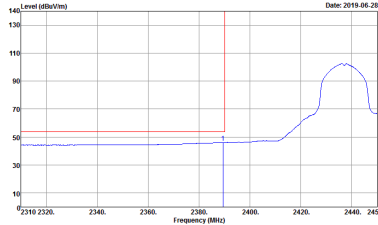
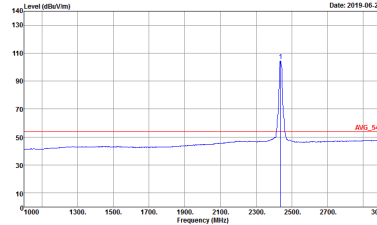

WIFI	2.4GHz 2400~2483.5MHz Band Edge @ 3m	
ANT	802.11ac VH20 CH06 2437MHz - L	
1+2	Vertical	Fundamental
Peak	 <p>Site : 03CH12-HY Condition : PEAK_BE_74 3m HORN_9120D_1328 VERTICAL Detector : Peak Project : 952409 Mode : 19 Setting : 17</p>	 <p>Site : 03CH12-HY Condition : PEAK_74 3m HORN_9120D_1328 VERTICAL Detector : Peak Project : 952409 Mode : 19 Setting : 17</p>
Avg.	 <p>Site : 03CH12-HY Condition : AVG_BE_54 3m HORN_9120D_1328 VERTICAL Detector : Peak Project : 952409 Mode : 19 Setting : 17</p>	 <p>Site : 03CH12-HY Condition : AVG_54 3m HORN_9120D_1328 VERTICAL Detector : Peak Project : 952409 Mode : 19 Setting : 17</p>



WIFI	2.4GHz 2400~2483.5MHz Band Edge @ 3m	
ANT	802.11ac VH20 CH06 2437MHz - R	
1+2	Vertical	Fundamental
<p>Peak</p>		<p>Left blank</p>
<p>Avg.</p>		<p>Left blank</p>

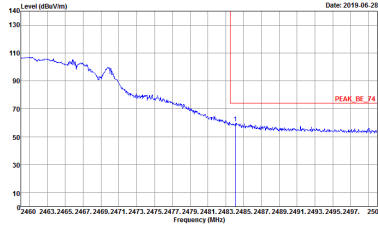
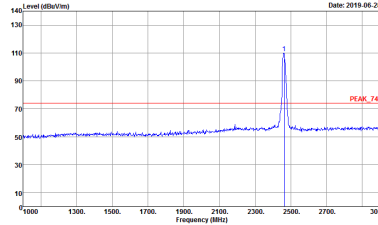
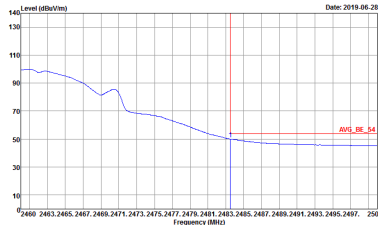
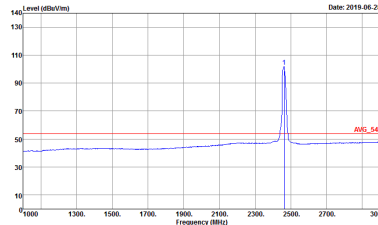

WIFI	2.4GHz 2400~2483.5MHz Band Edge @ 3m	
ANT	802.11ac VH20 CH11 2462MHz	
1+2	Horizontal	Fundamental
<p>Peak</p>	 <p>Date: 2019.06.28</p> <p>Site : 03CH12-HY Condition : PEAK_BE_74 3m HORN_9120D_1328 HORIZONTAL Detector : Peak Project : 952409 Mode : 20 Setting : 15.5</p>	 <p>Date: 2019.06.28</p> <p>Site : 03CH12-HY Condition : PEAK_74 3m HORN_9120D_1328 HORIZONTAL Detector : Peak Project : 952409 Mode : 20 Setting : 15.5</p>
<p>Avg.</p>	 <p>Date: 2019.06.28</p> <p>Site : 03CH12-HY Condition : AVG_BE_54 3m HORN_9120D_1328 HORIZONTAL Detector : Peak Project : 952409 Mode : 20 Setting : 15.5</p>	 <p>Date: 2019.06.28</p> <p>Site : 03CH12-HY Condition : AVG_54 3m HORN_9120D_1328 HORIZONTAL Detector : Peak Project : 952409 Mode : 20 Setting : 15.5</p>



WIFI	2.4GHz 2400~2483.5MHz Band Edge @ 3m	
ANT	802.11ac VH20 CH11 2462MHz	
1+2	Vertical	Fundamental
Peak	<p>Date: 2019.06.28</p> <p>Site : 03CH12-HY Condition : PEAK_BE_74 3m HORN_9120D_1328 VERTICAL RBW:3000.000kHz VBW:3000.000kHz SWT:Auto Detector : Peak Project : 952409 Mode : 20 Setting : 15.5</p>	<p>Date: 2019.06.28</p> <p>Site : 03CH12-HY Condition : PEAK_74 3m HORN_9120D_1328 VERTICAL RBW:3000.000kHz VBW:3000.000kHz SWT:Auto Detector : Peak Project : 952409 Mode : 20 Setting : 15.5</p>
Avg.	<p>Date: 2019.06.28</p> <p>Site : 03CH12-HY Condition : AVG_BE_54 3m HORN_9120D_1328 VERTICAL RBW:3000.000kHz VBW:1.000kHz SWT:Auto Detector : Peak Project : 952409 Mode : 20 Setting : 15.5</p>	<p>Date: 2019.06.28</p> <p>Site : 03CH12-HY Condition : AVG_54 3m HORN_9120D_1328 VERTICAL RBW:3000.000kHz VBW:1.000kHz SWT:Auto Detector : Peak Project : 952409 Mode : 20 Setting : 15.5</p>



2.4GHz 2400~2483.5MHz

WIFI 802.11b (Harmonic @ 3m)

WIFI	2.4GHz 2400~2483.5MHz Harmonic @ 3m	
ANT	802.11b CH01 2412MHz	
1+2	Horizontal	Vertical
Peak Avg.	<p>Site : 03CH12-4Y Condition : PEAK_74 3m HORN_91200_1328 HORIZONTAL Detector : Peak Project : 952409 Mode : 12 Setting : 18</p>	<p>Site : 03CH12-4Y Condition : PEAK_74 3m HORN_91200_1328 VERTICAL Detector : Peak Project : 952409 Mode : 12 Setting : 18</p>

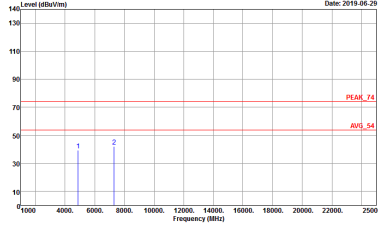
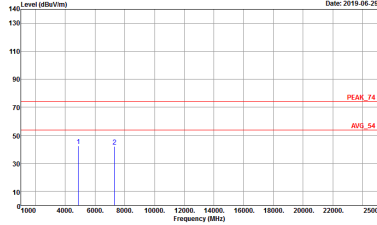

WIFI	2.4GHz 2400~2483.5MHz Harmonic @ 3m	
ANT	802.11b CH06 2437MHz	
1+2	Horizontal	Vertical
<p>Peak</p> <p>Avg.</p>	 <p>Site : 03CH2-11Y Condition : PEAK_74 3m HORN_91200_1328 HORIZONTAL Detector : Peak Project : 952409 Mode : 13 Setting : 18</p>	 <p>Site : 03CH2-11Y Condition : PEAK_74 3m HORN_91200_1328 VERTICAL Detector : Peak Project : 952409 Mode : 13 Setting : 18</p>

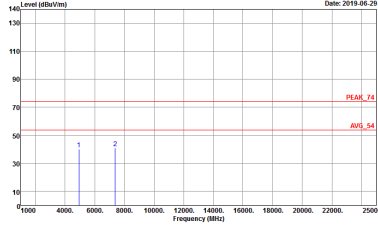
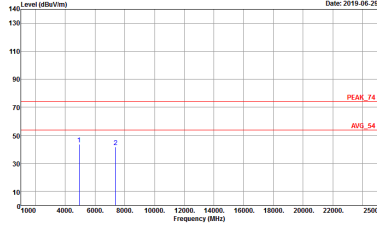

WIFI	2.4GHz 2400~2483.5MHz Harmonic @ 3m	
ANT	802.11b CH11 2462MHz	
1+2	Horizontal	Vertical
<p>Peak</p> <p>Avg.</p>	 <p>Site : 03CHZ-11Y Condition : PEAK_74 3m HORN_9120D_1328 HORIZONTAL Detector : Peak Project : 952409 Mode : 14 Setting : 18</p>	 <p>Site : 03CHZ-11Y Condition : PEAK_74 3m HORN_9120D_1328 VERTICAL Detector : Peak Project : 952409 Mode : 14 Setting : 18</p>



2.4GHz 2400~2483.5MHz

WIFI 802.11g (Harmonic @ 3m)

WIFI	2.4GHz 2400~2483.5MHz Harmonic @ 3m	
ANT	802.11g CH01 2412MHz	
1+2	Horizontal	Vertical
Peak Avg.	<p>Site : 03CH12-44Y Condition : PEAK_74 3m HORN_91200_1328 HORIZONTAL Detector : Peak Project : 952409 Mode : 15 Setting : 15.5</p>	<p>Site : 03CH12-44Y Condition : PEAK_74 3m HORN_91200_1328 VERTICAL Detector : Peak Project : 952409 Mode : 15 Setting : 15.5</p>



WIFI	2.4GHz 2400~2483.5MHz Harmonic @ 3m	
ANT	802.11g CH06 2437MHz	
1+2	Horizontal	Vertical
Peak Avg.	<p>Site : 03CHZ-11Y Condition : PEAK_74 3m HORN_9120D_1328 HORIZONTAL Detector : Peak Project : 952409 Mode : 16 Setting : 17</p>	<p>Site : 03CHZ-11Y Condition : PEAK_74 3m HORN_9120D_1328 VERTICAL Detector : Peak Project : 952409 Mode : 16 Setting : 17</p>



WIFI	2.4GHz 2400~2483.5MHz Harmonic @ 3m	
ANT	802.11g CH11 2462MHz	
1+2	Horizontal	Vertical
Peak Avg.	<p>Site : 03CHZ-11Y Condition : PEAK_74 3m HORN_91200_1328 HORIZONTAL Detector : Peak Project : 952409 Mode : 17 Setting : 14.5</p>	<p>Site : 03CHZ-11Y Condition : PEAK_74 3m HORN_91200_1328 VERTICAL Detector : Peak Project : 952409 Mode : 17 Setting : 14.5</p>



2.4GHz 2400~2483.5MHz

WIFI 802.11ac VHT20 (Harmonic @ 3m)

WIFI	2.4GHz 2400~2483.5MHz Harmonic @ 3m	
ANT	802.11ac VHT20 CH01 2412MHz	
1+2	Horizontal	Vertical
Peak Avg.	<p>Site : 03CH12-447 Condition : PEAK_74 3m HORN_91200_1328 HORIZONTAL Detector : Peak Project : 952409 Mode : 1B Setting : 14.5</p>	<p>Site : 03CH12-447 Condition : PEAK_74 3m HORN_91200_1328 VERTICAL Detector : Peak Project : 952409 Mode : 1B Setting : 14.5</p>



WIFI	2.4GHz 2400~2483.5MHz Harmonic @ 3m	
ANT	802.11ac VHT20 CH06 2437MHz	
1+2	Horizontal	Vertical
Peak Avg.	<p>Site : 03CH12-11Y Condition : PEAK_F4 3m HORN_91200_1328 HORIZONTAL Detector : Peak Project : 952409 Mode : 19 Setting : 17</p>	<p>Site : 03CH12-11Y Condition : PEAK_F4 3m HORN_91200_1328 VERTICAL Detector : Peak Project : 952409 Mode : 19 Setting : 17</p>



WIFI	2.4GHz 2400~2483.5MHz Harmonic @ 3m	
ANT	802.11ac VHT20 CH11 2462MHz	
1+2	Horizontal	Vertical
Peak Avg.	<p>Site : 03CH2-11Y Condition : PEAK_74 3m HORN_91200_1328 HORIZONTAL Detector : Peak Project : 952409 Mode : 20 Setting : 15.5</p>	<p>Site : 03CH2-11Y Condition : PEAK_74 3m HORN_91200_1328 VERTICAL Detector : Peak Project : 952409 Mode : 20 Setting : 15.5</p>



Emission below 1GHz
2.4GHz WIFI 802.11ac VHT20 (LF)

Table with 3 columns: WIFI (2.4GHz 2400~2483.5MHz), ANT (802.11ac VHT20 LF), and 1+2 (Horizontal/Vertical). It contains two spectral plots showing signal levels (dBuV/m) vs Frequency (MHz) for horizontal and vertical orientations. Includes metadata like Site, Condition, Detector, and Project.



Appendix E. Duty Cycle Plots

Antenna	Band	Duty Cycle(%)	T(us)	1/T(kHz)	VBW Setting	Duty Factor(dB)
1	802.11b	98.95	-	-	10Hz	0.05
2	802.11b	99.03	-	-	10Hz	0.04
1+2	802.11b for Ant 1	99.03	-	-	10Hz	0.04
1+2	802.11b for Ant 2	99.03	-	-	10Hz	0.04
1	802.11g	97.31	2024	0.49	1kHz	0.12
2	802.11g	97.31	2024	0.49	1kHz	0.12
1+2	802.11g for Ant 1	97.67	2016	0.50	1kHz	0.10
1+2	802.11g for Ant 2	97.54	2024	0.49	1kHz	0.11
1	2.4GHz 802.11n HT20	97.67	1890	0.53	1kHz	0.10
2	2.4GHz 802.11n HT20	97.68	1895	0.53	1kHz	0.10
1+2	2.4GHz 802.11n HT20 for Ant 1	97.94	1900	0.53	1kHz	0.09
1+2	2.4GHz 802.11n HT20 for Ant 2	97.93	1890	0.53	1kHz	0.09
1	2.4GHz 802.11ac VHT20	97.94	1905	0.52	1kHz	0.09
2	2.4GHz 802.11ac VHT20	97.69	1900	0.53	1kHz	0.10
1+2	2.4GHz 802.11ac VHT20 for Ant 1	97.69	1905	0.52	1kHz	0.10
1+2	2.4GHz 802.11ac VHT20 for Ant 2	97.95	1910	0.52	1kHz	0.09



<Ant. 1>

802.11b

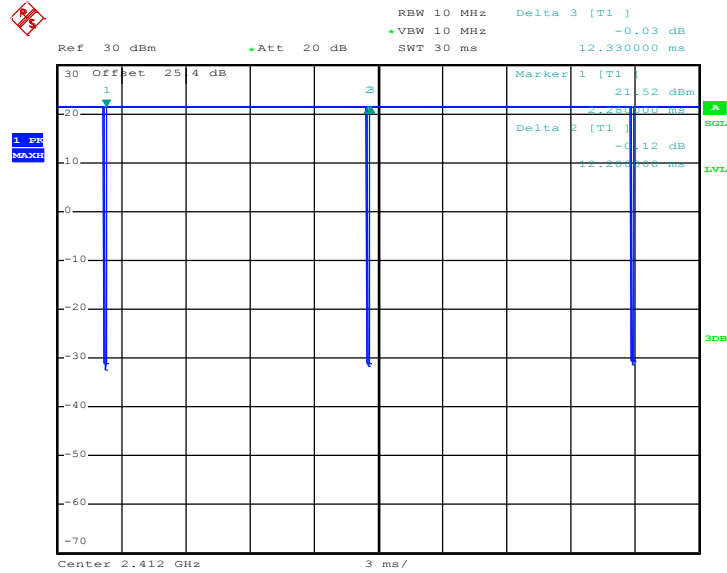

Date: 10.JUN.2019 00:05:47

802.11g

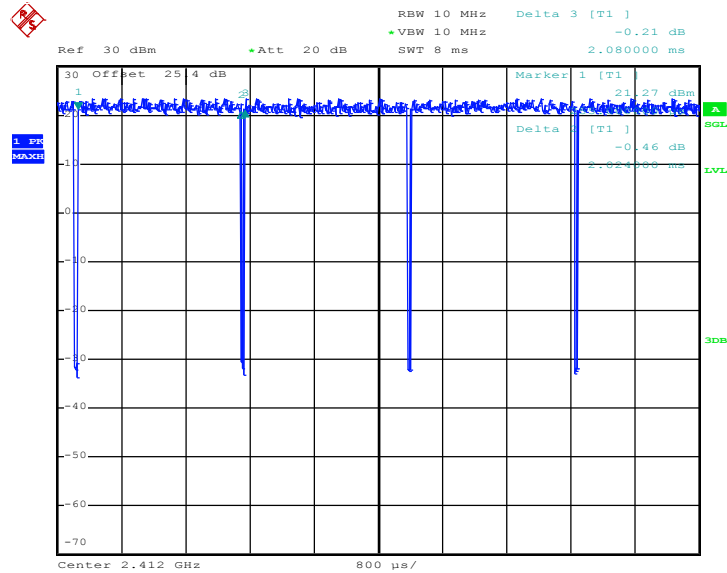

Date: 10.JUN.2019 00:28:53



802.11n HT20

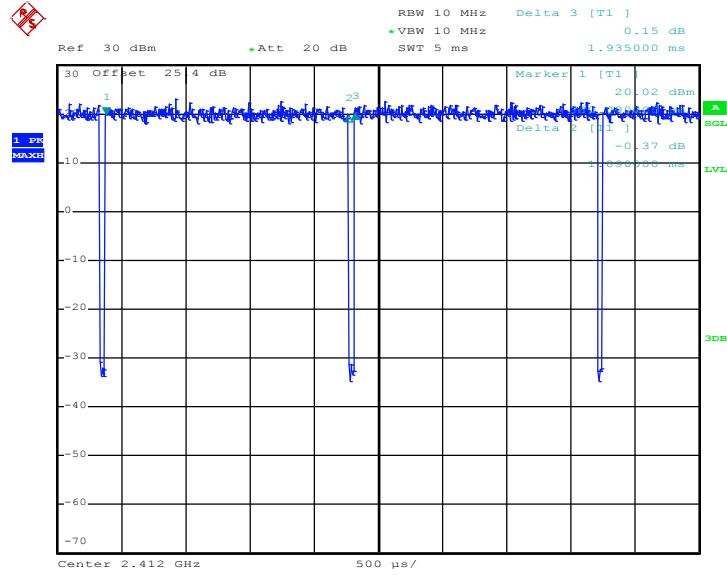

Date: 10.JUN.2019 01:27:08

802.11ac VHT20

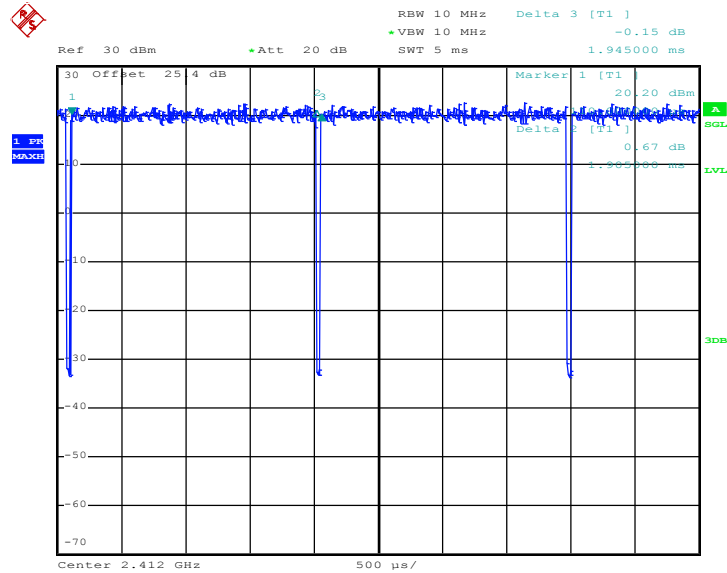

Date: 10.JUN.2019 01:00:01



<Ant. 2>

802.11b

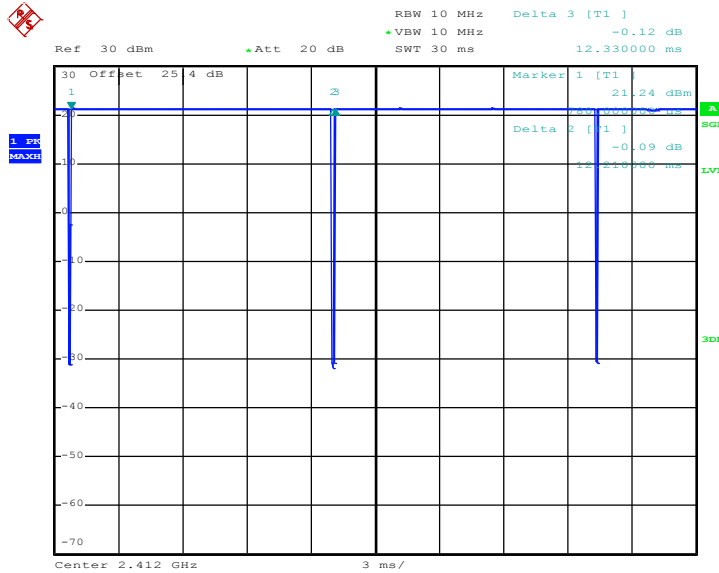

Date: 10.JUN.2019 00:13:53

802.11g

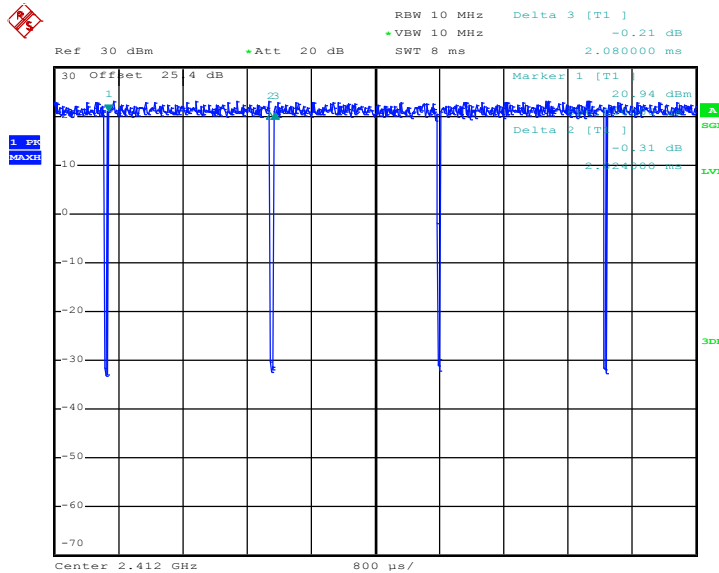

Date: 10.JUN.2019 00:29:55



802.11n HT20

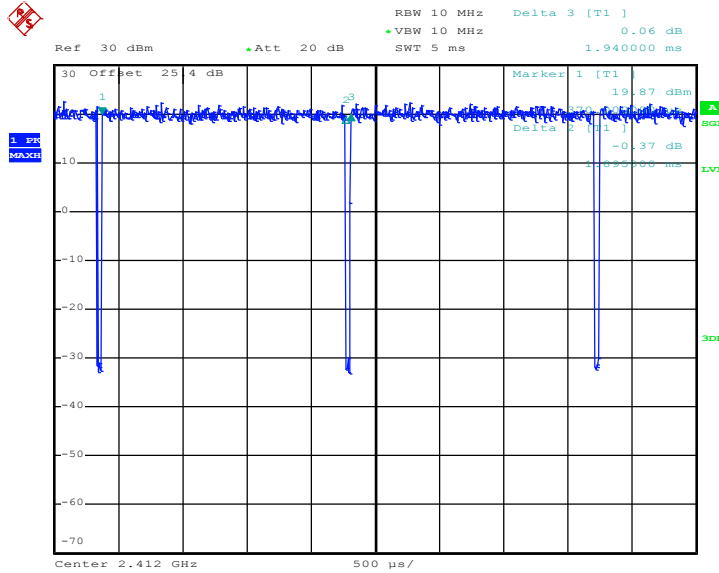

Date: 10.JUN.2019 01:28:06

802.11ac VHT20

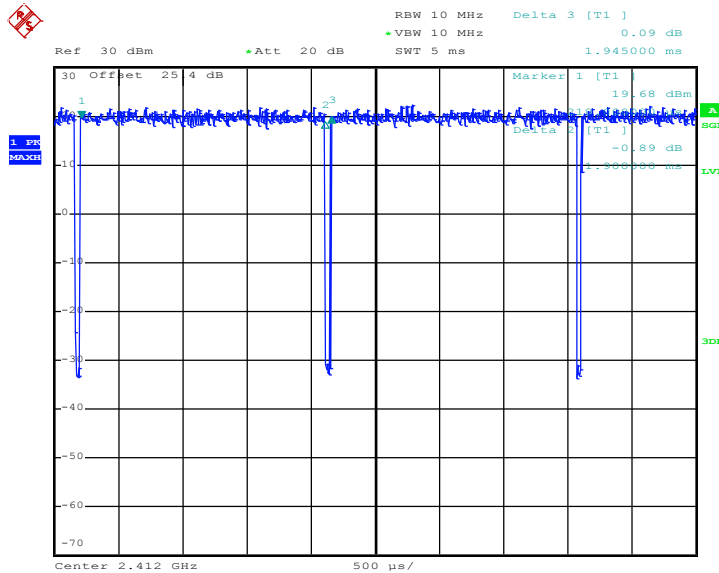

Date: 10.JUN.2019 01:02:38



MIMO <Ant. 1>

802.11b

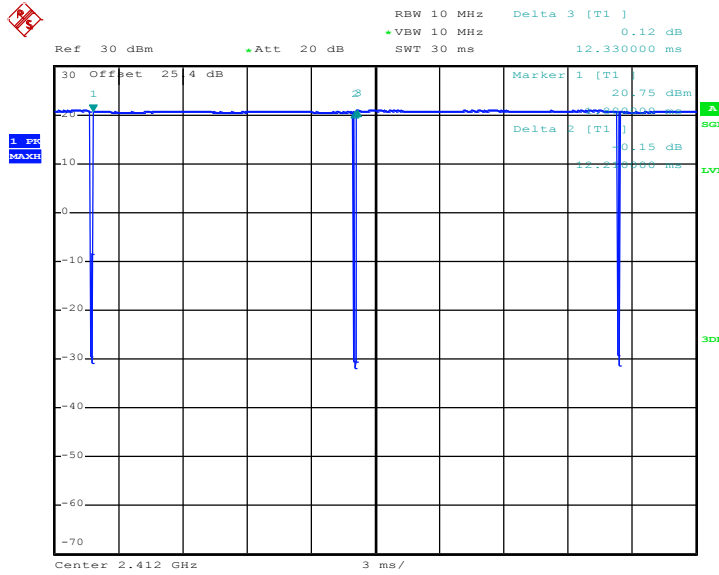

Date: 10.JUN.2019 00:15:05

802.11g

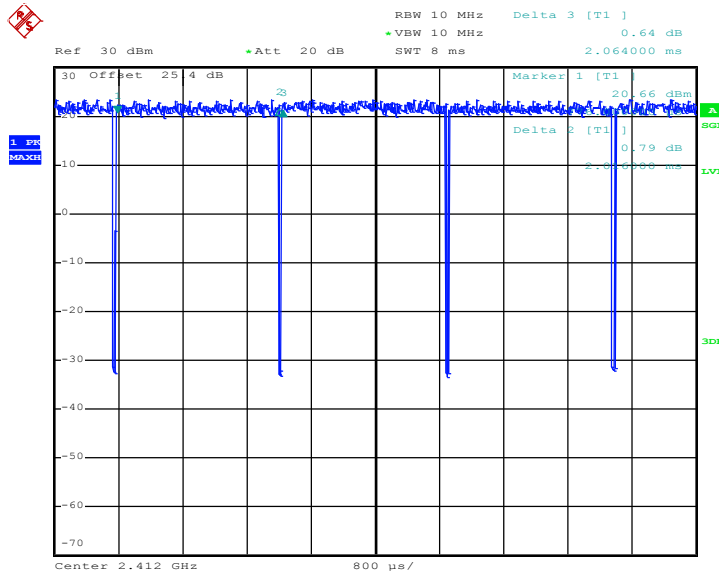

Date: 10.JUN.2019 00:26:45



802.11n HT20

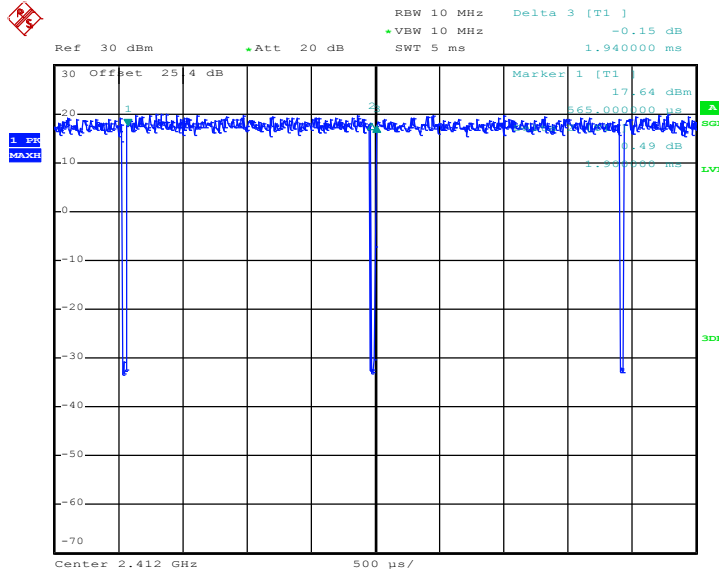

Date: 27.JUN.2019 00:38:56

802.11ac VHT20

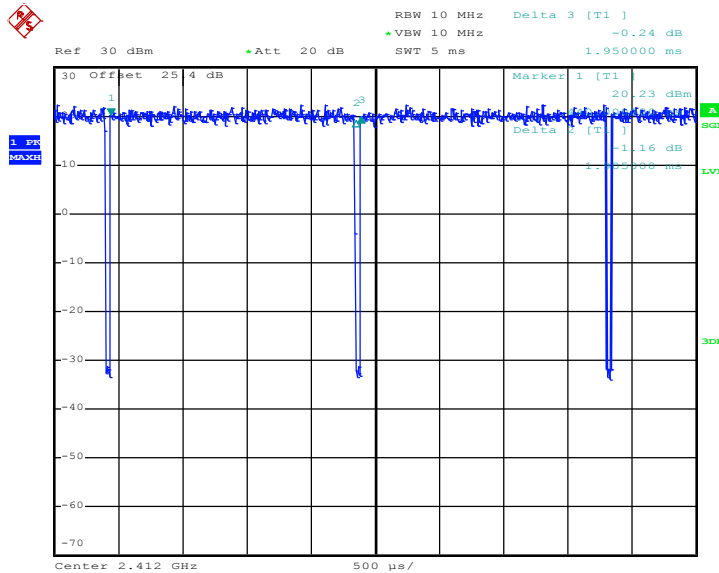

Date: 10.JUN.2019 00:54:13



MIMO <Ant. 2>

802.11b

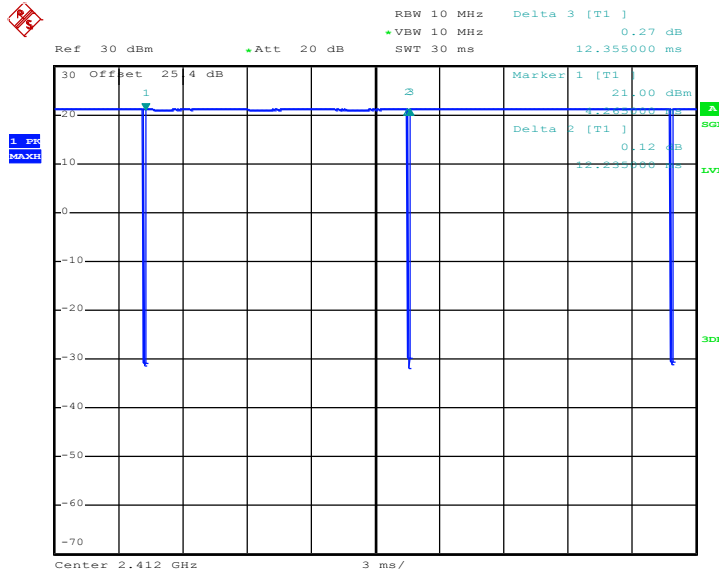

Date: 10.JUN.2019 00:16:00

802.11g

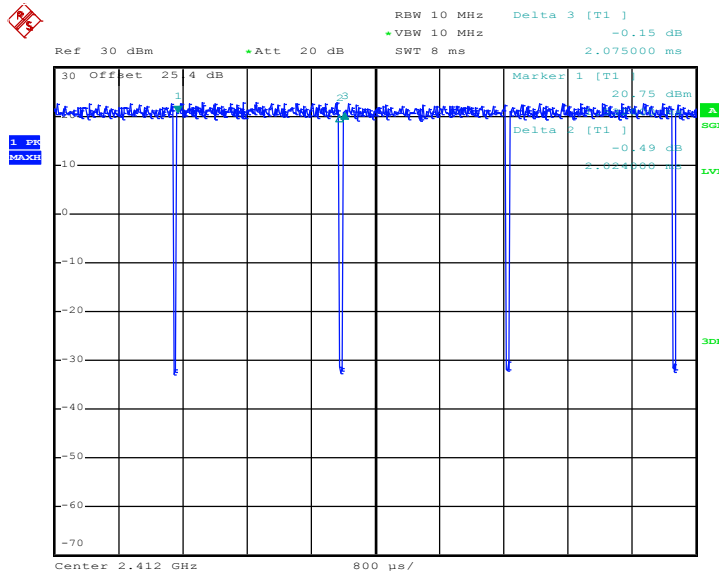

Date: 10.JUN.2019 00:27:34



802.11n HT20

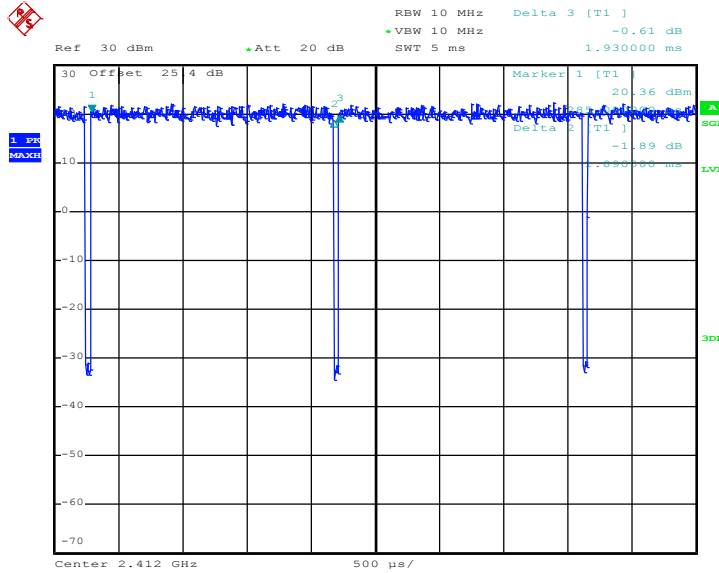

Date: 10.JUN.2019 01:30:49

802.11ac VHT20

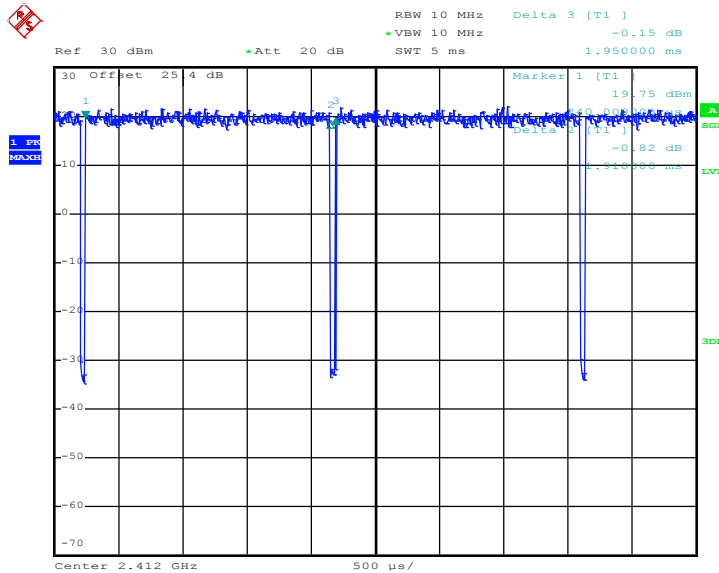

Date: 10.JUN.2019 00:55:01