

# **EVO Max 4T**

## **user's manual**

2022.12

V1.0



**Manufacture: Autel Robotics Co., Ltd.**

**Address: 601, 701, 801, 901, Block B1, Nanshan iPark, No. 1001 Xueyuan  
Avenue, Nanshan District, Shenzhen, Guangdong, 518055, China**

# Reading tips

## The legend symbol

Pay special attention to the legend symbols present in this manual.



Warning: Reminder of potentially dangerous situations.



Important: Matters in flight operation.



Note: Supplementary information.



Tip: Tips about getting the best operating experience.



Reference: Page numbers to help you find the section in this manual containing contains information.

## Trademark information

EVO Max™, Autel Enterprise™, Starpoint™ and Autel Robotics® are the registered trademarks of Shenzhen Daotong Intelligent Aviation Technology Co., Ltd. (hereinafter referred to as "Daotong Intelligent") in China and other countries / regions. All other products and company names mentioned in this user manual are registered trademarks of their respective holders.

## Copyright warning

This manual and ownership are owned by Daotong Intelligence. Without the express written consent of Daotong Intelligence, no person or entity shall copy or forward any part of this manual in any form or by any means (including, but not limitation, electronic, mechanical, copied, recorded or otherwise) without Daotong Intelligence. This manual is only used for the use and operation of this series of products, and shall not be used for other purposes.

## Patent information

This product was obtained according to the patent procedure. The patent number is as follows:

## D

Daotong Intelligence provides the following documentation and teaching videos for the first time using EVO Max 4T.

1. **Quick Guide: Basic knowledge of operating products**
2. Product List: list of all items to be included in the box. If any items are missing, contact the Smart User Support or authorized dealer.
3. Battery Safety Operation Guidelines: Basic knowledge and safe operation of batteries.
4. **Disclaimer and Safe Operation Guidelines: Instructions on how to operate the product safely.**
5. **The Product Maintenance Manual:**
6. **User Manual: Guide you to master the operation method of the product.**

## Watch the teaching video

Watch the EVO Max 4T teaching video, scan the QR code or access the website:  
<https://www.autelrobotics.cn/article/128.html>

## Recommended reading order

1. Is the User Manual divided into? Two chapters are: first flight notice, Daotong intelligent aircraft EVO Max 4T, intelligent remote control, battery, Autel Enterprise App.
2. Daotong Intelligent advises users to check the items contained in the packing box according to the Product List ". If any items are missing, please contact the Daotong Intelligent User Support or an authorized dealer.
3. **Read this document in detail, use the Quick Guide and watch the teaching video to understand the use process. Please carefully read the User Manual, Disclaimer and Safe Use Guidelines and Battery Safe Operation Guidelines before flight to ensure the safe operation and use of all functions**
4. Before using the aircraft, ensure that you are familiar with the local laws and regulations related to flight, the functions of the aircraft, the flight control, and the intelligent return process. If you have any questions about using this product, please contact the Daotong Smart User Support or an authorized dealer.

## download

Download EVO Max 4T For the software, visit:

<https://www.autelrobotics.cn/download/23.html>

### warn

Be sure to check the aircraft and other components listed in the list of products in the packing box. Do not use incompatible parts or attempt to modify this aircraft in any manner that does not comply with the official instructions.

## catalogue

Reading tips.....	2
The legend symbol .....	2
Trademark information .....	2
Copyright warning.....	2
Patent information.....	2
D .....	3
Watch the teaching video .....	3
<b>Recommended reading order.....</b>	<b>3</b>
download .....	4
Chapter 1:First flight notice.....	6
1.1 First-time use .....	6
.1.11 Charging .....	6
.1.21 Prepare the aircraft .....	7
.1.31 Expand the arm .....	9
1.1.4 Installing / removing the propeller.....	9
.1.51 Prepare the remote control .....	10
<b>.21 Flight safety.....</b>	<b>10</b>
1.2.1 Hazard avoidance system (multi-source sensor fusion sensing system).....	11
1.3 Intelligent flight characteristics .....	15
1.3.1 Automatic return flight.....	15
.3.21 Descent characteristics.....	16
<b>.41 Flight restrictions .....</b>	<b>17</b>
.4.11 Limit the flight area .....	17
<b>.4.21 Buffer area .....</b>	<b>17</b>
.4.31. Application for lifting the ban .....	17

.4.41. Limit the height limit .....	17
.5 1 Pre-flight checklist .....	17
1.6 Flight operation .....	18
1.6.1 Motor start / close .....	19
1.6.2 Aircraft take-off / landing .....	20
Chapter 2: Daotong intelligent aircraft EVO Max 4T .....	23
.12 Product profile .....	23
2.1.1 Part introduction .....	23
2.1.2, the flight indicator light .....	25
2.2.1 Cloud head working mode .....	28
.2.22 Remove / install the cloud head .....	28
2.3 Camera .....	29
2.3.1 Camera operation .....	29
2.4 Flight control system .....	30
.4.12 Flight mode .....	31
.4.22 Acceleration mode (flight gear) switch .....	31
2.4.3 Intelligent flight function .....	32
.52 Data storage / transmission .....	33
.5.12 Use the microSD card .....	33
.5.22 Transfer the files to the P C/Mac .....	34
Chapter 3: A utellIntelligent remote control .....	36
3.1 Product Introduction .....	36
.13.1 Part introduction .....	36
3.2 First-time use .....	39
. 1 Expand the remote control .....	39
.2.13 Smart remote control power and charging .....	40
.2.33 Installation and use of accessories .....	41
3.2.4 Adjust the antenna .....	42
3.2.5 Frequ, calibration and joystick mode selection of intelligent remote control .....	43
.33 Key function .....	47
<b>.3.13 Automatic takeoff / return button, pause button .....</b>	<b>47</b>
<b>.3.23 Custom key C 1 / C2 .....</b>	<b>47</b>
3.4 AutelSkyLink map transfer function .....	49
3.5 Equipment calibration .....	49
3.5.1, and the compass calibration .....	49
3.5.2IMU calibration .....	50
3.6 Remote control prompt tone .....	50
3.7 Picture transmission and picture output .....	51
3.7.1H DMI interface .....	51
3.7.2 Live streaming function .....	51
Chapter 4: Intelligent flight battery .....	53
.14 Product profile .....	53

.14.1 Part introduction .....	53
.24 Battery use .....	53
1. Install the aircraft battery.....	53
2. Remove the aircraft battery .....	53
.2.14. Battery power view and charging.....	53
4.3 Battery function .....	55
4.4 Additional functions .....	58
4.5 Battery storage and disposal .....	60
Chapter 5: Autel Enterprise App .....	62
Product profile .....	62
Chapter 6: Firmware update and equipment maintenance.....	66
6.1 Firmware update .....	66
6.1.1 Firmware download and upgrade .....	66
6.2 Product maintenance and maintenance .....	67
6.2.1 Product maintenance .....	67
6.2.2 Storage and maintenance .....	68
6.3 Warranty policy .....	68
6.4 Customer service.....	68
6.4.1 Customer Support .....	68
6.4.2 Maintenance and service .....	69
Chapter 7: Appendix .....	70
<b>7.1 Specifications.....</b>	<b>70</b>

## Chapter 1:First flight notice

Thank you for purchasing EVO Max 4T, through this manual you can understand the characteristics of the product and learn to operate the aircraft and remote control in the best way. Before first using the product, please read this manual and other accompanying documents for inquiry.

### 1.1 First-time use

For the first use, your EVO Max 4T and remote control are in the following steps:

#### .1.11 Charging

Please use the official standard battery single charger and charger, and connect them to the smart flight battery and the remote control UCB-C interface for charging respectively, to wake up the use state of the battery.(Please refer to the section 4 )

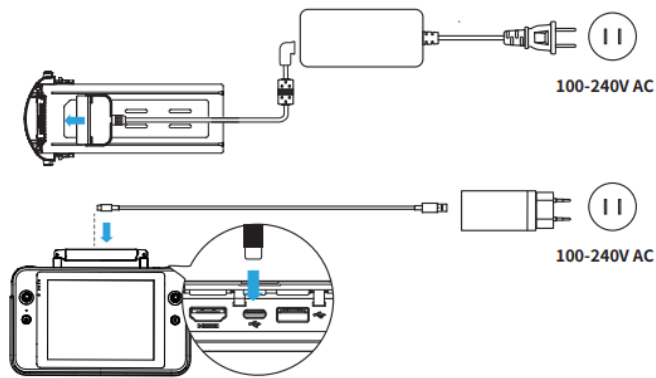

### .1.21 Prepare the aircraft

Remove the cover: tap the cover and remove it.

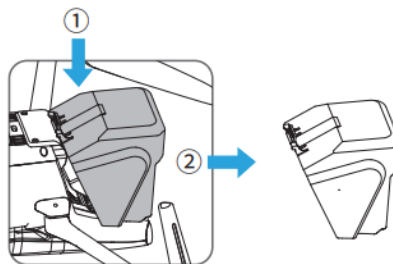

#### ! important

After closing the aircraft, the cradle head protection cover should be installed back in time to prevent damage to the cradle head.

Align the smart flight battery from behind the rear of the aircraft fuselage and push it in

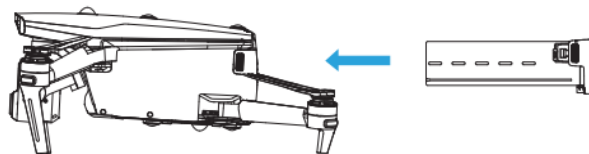

Insert the micro SD memory card to the card slot behind the fuselage

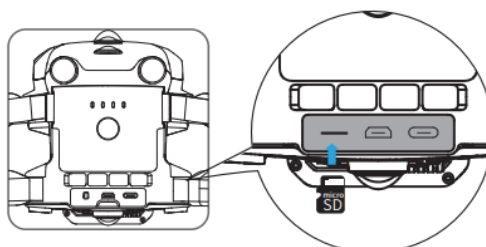

 **important**

Before inserting the micro SD card, ensure that the side with the metal contact feature faces up (as shown) to avoid damage to the vehicle card slot and the micro SD card.



### .1.31 Expand the arm

When expanding the left / right arm, expand the front arm and then the rear arm.

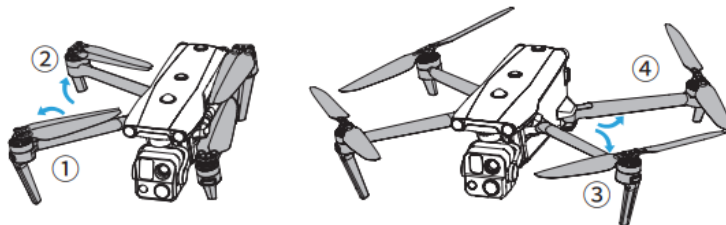

**! important**

- Please deploy the aircraft arm before turning on the aircraft power supply.
- Turn off the aircraft power switch before folding the aircraft arm.



### 1.1.4 Installing / removing the propeller

EVO Max 4T Using the fast dismantling propeller design, the aircraft factory has been installed on the four arm propeller. Refer to the following steps to install / remove the propeller:

● **Install propeller**

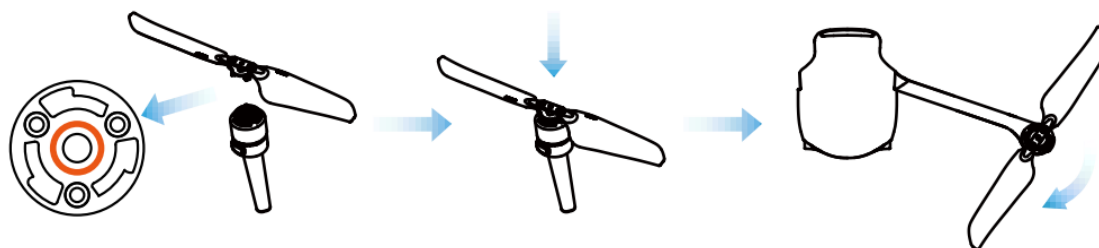
Select the matching propeller corresponding to each motor. Press the propeller midshaft position vigorously as shown, and then turn in the locking direction, so that the propeller is installed firmly.



screw propeller	With a white color label	No white color labels
installation site	Install to the white-marked mount	Install to an unmarked mount
legend	 Lock direction: Turn the propeller to tighten it as shown.  Unlocking direction: Turn the propeller to remove it as shown.	

● **Remove the propeller**

1. Turn off the aircraft.
2. Press the propeller hard and rotate in the unlock direction to remove the propeller.

**⚠ warn**

- Ensure that the vehicle power is turned off before installing or removing the propeller.
- Wear protective gloves when installing or removing the propeller.
- Do not touch the rotating propeller or motor.
- Before flight, check that each propeller is indeed firmly installed.
- Do not use broken propellers to fly.
- Before testing the motor, first ensure that the propeller is removed.

### .1.51 Prepare the remote control

Remove the handle from the back of the remote control and install the joystick

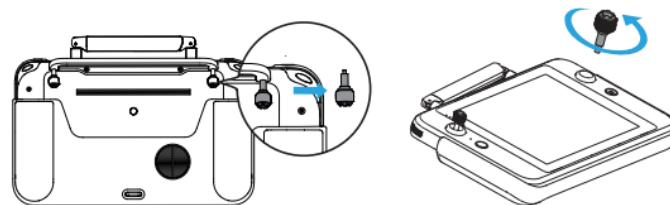

When used for the first time, the antenna of the remote control is in the storage state and needs to be expanded

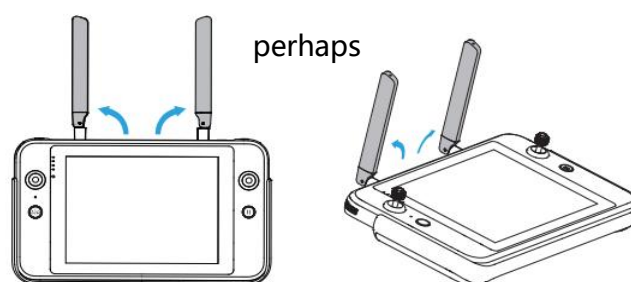

## .21 Flight safety

Before using the aircraft, please conduct the relevant basic flight training, be familiar with the functions and characteristics of the aircraft and the remote control, or be guided by a professional. Before the flight begins, please understand all the local regulations on drone flight in advance. In order to know the local flight requirements and restrictions, using Autel Enterprise App to set the specified distance and altitude limits in an inappropriate flight environment (e. g.,

more than 120 m) may pose legal risks. Read and understand the Disclaimer and Safety Operation Guidelines before the flight to learn more about them.

### **flight environment of vehicle**

Do not fly in dangerous weather conditions such as gale, rain, hail, snow.

Fly in open areas away from populated areas, buildings and interference sources. Please fly below 6000m.

Due to insufficient light conditions, no GPS signal, and spatial stenosis, the use of some functions may be limited.

For night flight, please turn on the night navigation light function to ensure flight safety.

## **1.2.1 Hazard avoidance system (multi-source sensor fusion sensing system)**

EVO Max 4T The aircraft fuselage is equipped with a multi-source sensor fusion sensing system based on "binocular vision + millimeter wave radar", which has the long-distance detection ability of night obstacle detection, water surface height detection, wire and other small objects, realizing 360° all-round perception and obstacle avoidance, and helping the flight platform to realize all-weather and multi-scene operations.(To change, add a detailed description of the new sensor)

### **. 1 The omnidirectional vision sensor**

EVO Max 4T The front, rear, upper and lower binocular visual perception system uses image data to calculate the distance between the aircraft and potential obstacles. Once an obstacle is detected, the system will cause the vehicle to stop advancing. The binocular vision system at the front, rear and bottom also has a Starpoint positioning system. The system uses ultrasonic sensors to calculate the altitude of the aircraft, while the binocular camera obtains position information through image analysis.(To change, add a description of the new sensor)

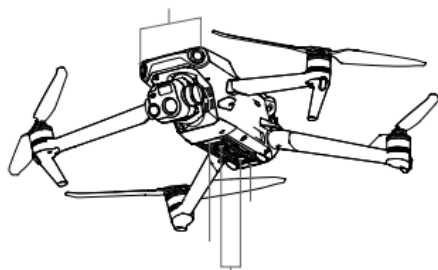

. (Mark 1 visual perception system 2. millimeter wave radar)

<b>Binocular visual perception system</b>		
<b>system</b>	<b>Position on the flying vehicle</b>	<b>Obobstacle sensing range</b>
front	The front of the aircraft	From 0.5 to 18 m
behind	Aircraft tail	From 0.5 to 16 m
Left / right	The rear of the left and right sides of the vehicle	From 0.5 to 10 m
falling- rising tone	The upper aircraft	From 0.5 to 10 m
Under	The lower part of aircraft	From 0.5 to 10 m

The following figure shows the coverage angle of each binocular visual sensing system:

## . 2. High-precision millimeter-wave radar

The fuselage is equipped with a 4-way millimeter-wave radar, with a detection range of more than 40 meters

(Picture of millimeter wave)

<b>Millimeter-wave radar sensing system</b>		
<b>system</b>	<b>Position on the flying vehicle</b>	<b>Obobstacle sensing range</b>
front	The front of the aircraft	
behind	Aircraft tail	
falling- rising tone	The upper aircraft	
Under	The lower part of aircraft	

### **remarks**

The omnidirectional induction direction of obstacles includes front, rear, top, bottom, left and right. However, there are blind spots in the four diagonal directions. When flying manually, please pay attention to the surrounding environment and App tips to ensure safety.

Do not fly in underlight environments, with small objects (such as twigs, wires, nets, etc.), moving objects, transparent surfaces (such as Windows), or complex areas of reflective surfaces (such as mirrors).

When following the car or other vehicle, please choose the field or closed route. Must not be used on highways.

### 3. Aircraft night navigation light

The top and bottom of the aircraft fuselage are each equipped with a night navigation light, which facilitates the identification of the aircraft when flying in a low-illumination environment, and can be opened or closed in the Autel Enterprise App.

(Night flight light drawing is required)

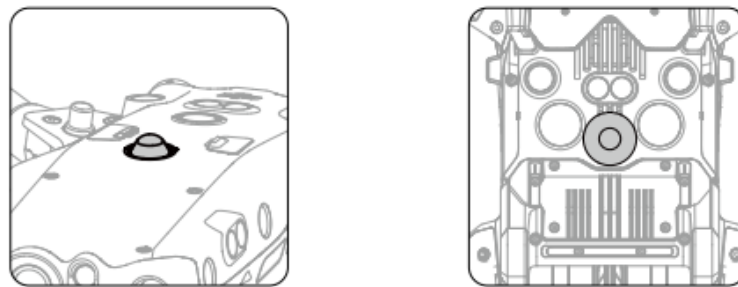

**⚠ Warning:** Do not look directly at the open night navigation light to avoid transient visual damage.

### . 4 fill light under the aircraft

A group of LED fill lights is equipped with at the bottom of the aircraft fuselage. When the aircraft is taking off or landing in a low illumination environment, the LED fill light will assist the visual positioning system, which can be turned on or off in Autel Enterprise App.

(LED lights in the following below)

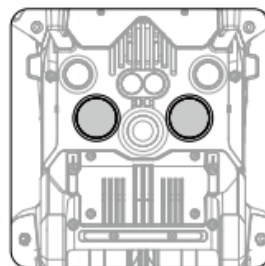

### **⚠ warn**

The lower replacement light will be in the low illumination environment and altitude? Below meters, it will automatically open. At this time, the visual sensor positioning performance is reduced. If the GNSS signal is not good, please operate the aircraft carefully.

### 5. prerequisite

Ensure that the vehicle is in a GPS or visual positioning mode.

Wait until the flight LED indicator becomes a slowly flashing green light or a twice-flashing red light before taking off.

Special care should be taken when the GPS signal is weak or fails to meet the visual positioning requirements (e. g., with a small visible texture on the surface, or when flying at more than 12 meters).

Binocular visual sensing system and Starpoint positioning system are affected by the brightness and texture of the lower surface of the vehicle. Avoid flying over the following surfaces:

Monochrome background or ground

High reflective, such as water surface

Especially bright or dark surfaces

The surface where the light often changes

Surfaces composed of highly repetitive patterns, such as ceramic tiles

Sound-absorbing surfaces, such as a thick carpet

Motor surfaces, such as roads with high traffic flow

Binocular camera lens and sensors should be kept clean.

To avoid interfering with the Starpoint positioning system, do not use a 40 kHz ultrasound device, such as an ultrasonic range finder, fault detector, cleaner, or welder.

## **1.3 Intelligent flight characteristics**

### **1.3.1 Automatic return flight**

#### **. 1 Out of control protection**

The function of runaway protection is to help the drone return automatically or land in its current position if necessary. The runaway protection is activated in the following two conditions.

#### **2. communication interrupt**

If the communication between the aircraft and the remote control is interrupted for 3 seconds, the runaway protection will start.

If the GPS signal is available when the runaway protection function is activated, the aircraft will activate the automatic return function. Otherwise, the vehicle will land in place. After the communication resumes, you can still press the pause button (⏸) to regain control of the vehicle.

#### **3. The flying vehicle battery level is low**

The runaway protection is activated when any of the following batteries is low.

- The aircraft continuously calculates the battery level required to return to the return site. The App displays a notification when the battery level reaches the maximum amount required for the vehicle to return to the return point. The runaway protection will be activated and the return process is initiated. Again, you can press the pause button () to regain control of the vehicle.
- When the battery level of the aircraft reaches the set threshold (default 25%), you will receive a low battery level warning, and the runaway protection activation, and the vehicle starts the automatic return flight. If you regain control of the vehicle, you will receive a critical battery insufficiency warning at 15%, and the vehicle will automatically land in place. In case of emergency, you can press the pause button () to pause the landing and manually fly the aircraft to the nearest safe landing site.

#### **remarks**

- When the aircraft battery level reaches 25% (low battery warning), if the horizontal distance from the vehicle return point is less than 50 meters (150 feet), the aircraft will not perform the automatic return program.
- If the GPS is not available when the battery is low warning, the aircraft will not perform the automatic return program. The vehicle will enter into ATTI mode and will remain under control. When the battery level reaches 15% (the battery level is seriously insufficient warning), the aircraft lands automatically.

### **.3.21 Descent characteristics**

#### **1. Landing protection**

When the aircraft reaches above the return point, the landing protection function will detect the ground environment below. If the ground is flat, the aircraft will land automatically. Otherwise, it will hover in place and wait for the next instruction.

#### **2. Precise landing**

When the precision landing function is activated, the aircraft will land as close to the takeoff point as possible.

#### **important**



- The aircraft records the takeoff point as the default return point. Accurate landing takes effect only when the return point is not refreshed during the flight.
- Choose an open, well-lit area as the takeoff point.
- When landing the aircraft by precise landing, ensure that the takeoff environment has not changed.
- Landing protection and accurate landing can be enabled using the App.

## **.41 Flight restrictions**

### **.4.11 Limit the flight area**

EVO Max 4T Can automatically identify the restricted flight zone, and avoid these areas by default during the flight. This function ensures that the vehicle complies with the legal flight area requirements.

#### **remarks**

- Fly hand shall ensure compliance with all relevant flight rules and regulations.

### **.4.21 Buffer area**

#### **.4.31. Application for lifting the ban**

- [If you need to release the ban, please log on the official website of Daotong Intelligence and apply according to the operation guidelines: www.autelrobotics.cn/page/noflight](http://www.autelrobotics.cn/page/noflight)

#### **.4.41. Limit the height limit**

Maintain flight altitude below 121.92m above ground level. This flight altitude is controlled and restricted by GPS positioning.

## **.5 1 Pre-flight checklist**

Follow these steps for a full pre-flight inspection:

- Ensure that the aircraft battery, the remote control battery power is sufficient, and the aircraft battery is installed in place.
- Ensure that the cloud head protection cover is removed. And check that the cradle head motor is in the normal working condition.
- Ensure that the motor, the head and the camera can work properly.
- Ensure that the propeller is properly installed and undamaged and that the vehicle components are fully installed.
- Expand the antenna of the remote control.

- Ensure that the aircraft and remote control are in the complete pairing state.
- Ensure that all warnings and errors displayed on the Autel Enterprise App are processed.
- Ensure that the Autel Enterprise App and firmware have been updated to the latest version.
- Ensure that you are familiar with the flight control operations.
- Check if the flight area is open and open.
- Ensure that the weather conditions, including air temperature and wind speed, are suitable for flying.
- Make sure the camera lens and the obstacle avoidance sensor are clean.
- If multiple aircraft are flying at the same time, please keep an appropriate airspace distance to avoid safety accidents.

 **important**

- Before starting the aircraft, make sure that the battery is installed in place (after installation, the edge of the battery fits closely to the fuselage) to avoid the flight safety caused by the battery loss during the flight.
- Only accessories supplied or sold or authorized with the aircraft can be used. Use of unapproved accessories can pose serious safety risks and void the product warranty.
- Wi-Fi is turned on for use when the aircraft is not flying( except in Canada and Japan, 5.2GHz Wi-Fi is for indoor use only). When flying, the Wi-Fi will be turned off, otherwise it will interfere with the image transmission.

## 1.6 Flight operation

The aircraft offers three rocker modes: American, Chinese, and Japanese. Each mode controls the vehicle differently, and the default mode is the American hand. The user can switch in the Autel Enterprise App according to the control habits (switch operation mode reference section). **The following is the basic operation process**

1. Place the aircraft in an open area. Stand at least 3 meters from the rear of the vehicle.
2. Open the remote control.
3. Turn on the aircraft and wait for the tail LED light to turn green and flash slowly.
4. Start the motor with the remote control and take off.
5. Carefully navigate the aircraft.
6. Land the aircraft and turn off the motor.

## 1.6.1 Motor start / close

1. Start the motor: break the left and right swing lever for 2 seconds



2. Close the motor: After the motor is started, the motor operation can be stopped by using the following two methods

- Method 1: When the flight is in the landing state, pull the throttle bar (left joystick) down to the bottom until the motor is closed.

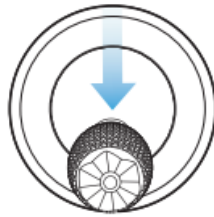

- Method 2: When the flight is in the landing state, the left and right rocker will break the rod until the motor is closed.



### **warn**

- The motor will heat during operation, please be careful for storage.
- When the vehicle battery level is 15% or lower, the vehicle cannot take off.
- Do not take the aircraft when the remote control is too low.

## 1.6.2 Aircraft take-off / landing

### 1. Aircraft take off

Place the aircraft on empty ground and pointing the tail towards the user, the aircraft is as follows:

Push up, the aircraft will slowly take off vertically and rise

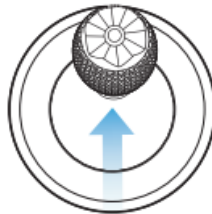

### 2. Aircraft landing

- The craft lands manually
  1. Find the right location for the aircraft to land (open and flat area).
  2. When the aircraft reaches the target position, release the rocker to hover over it.
  3. Pull the left joystick down to land the aircraft.
  4. When the aircraft reaches the ground, pull the left rocking lever to the bottom until the motor is closed

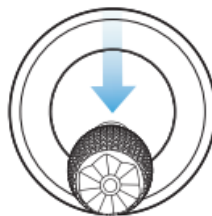

### remarks

When the battery low warning (25%), the LED behind the aircraft turns red and flashes, and return to the safe landing point as soon as possible.

- **The vehicle lands passively**

When one of the following conditions is met, runaway protection will be triggered and the vehicle will automatically land from its current position.

- Low battery warning activates in non-GPS environments.
- Battery underbattery warning activation.

 **important**

- When taking-off and landing, the aircraft should be far away from personnel, vehicles and other moving objects.
- The aircraft should not be taken out of your sight.
- When the aircraft relies on visual positioning, please do not be close to the mirror areas such as water or snow. When the GPS signal is poor, please ensure that the drone flies in a good light environment.
- When the battery appears a low power alarm, the automatic return process should not be cancelled. Otherwise, the aircraft may not have enough power to return to the return point.
- When the Autel Enterprise App shows an alarm, it should immediately follow the corresponding instructions.
- Make sure you are not intoxicated, high blood pressure, vertigo, fatigue or any other physical condition that may affect the ability to operate the aircraft safely.

# **aerobat**

Function and use of each component of the aircraft

## Chapter 2: Daotong intelligent aircraft EVO Max 4T

### .12 Product profile

The EVO™Max 4T (hereinafter referred to as the EVO Max 4T) is equipped with a 640512 thermal imaging camera and a 4K visible light camera, which can take both thermal imaging and visible light images at the same time, and supports the picture-in-picture mode.

The body is equipped with 12 visual sensors, with omnidirectional obstacle avoidance function. The App provides users with dozens of intelligent photography modes and various mission flight modes, such as rectangular, polygonal, aerial missions, and tilt photography, so that users can plan their aerial points and routes according to their actual needs.(To change)

#### 2.1.1 Part introduction

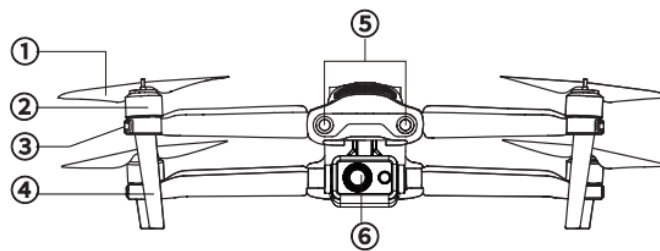

(EVO Max front view)

- |  |                              |
|--|------------------------------|
| ① screw propeller                              | ④ landing chassis            |
| ② any power-generating or power-driven machine | ⑤ Front visual visual system |
| ③ Head LED indicator light                     | ⑥ Pier Camera                |

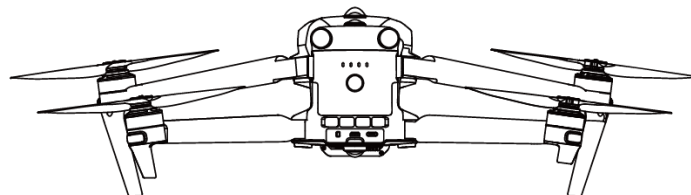

(graphEVOMax)

- |                |                            |
|----------------|----------------------------|
| ⑦ power button | ⑨ Tail LED indicator light |
|----------------|----------------------------|

⑧ Rear visual system

⑩ micro SD Card slot

⑪ External SSD interface

⑫ The USB-C interface

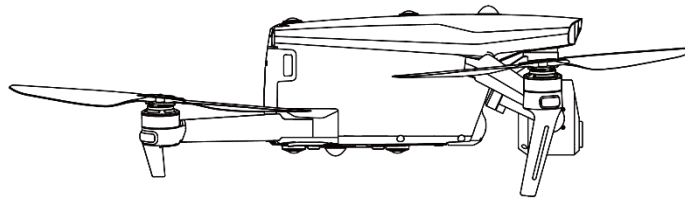
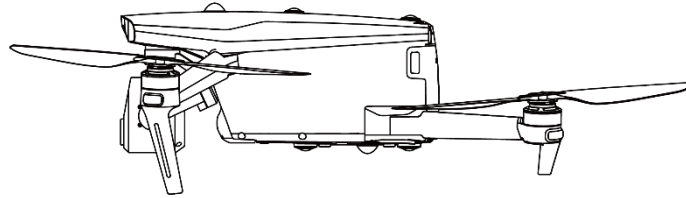

(Figure EVO Max Left side requires component description)

(No figure on EVO Max right)

⑫ Right-side visual system

⑭ Fan exhaust air port

⑬ Vehicle battery

⑯ Fancy button / indicator



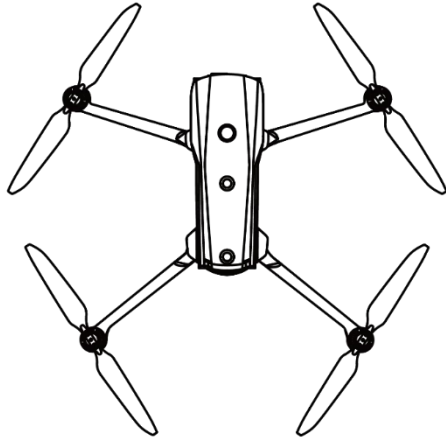

⑱ ultrasonic sensor

⑰ Upper visual system

⑲ LED fill light

⑳ Lower visual system

#### remarks

There is a protective cover under the micro SD card slot, external SSD interface, and USB-C interface. Make sure that the protection cover remains closed during flight.

For the parts not explicitly allowed in this manual, do not remove the parts installed when the aircraft leaves the factory, otherwise the product will lose the warranty qualification (newly added).

### 2.1.2, the flight indicator light

The aircraft has an LED indicator light at the end of each arm. Head LED is stable red, can help you identify the nose direction. The tail LED will display the current flight status of the aircraft. The following table shows the meaning of each status indicator light.

**pilot lamp:**

Slow flicker: flicker every 2 seconds

**Quick flash: blink twice per second**

Alternate flicker: flicker alternately in different colors

**pigment:****R** red**G** green**Y** yellow

<b>Light status definition (check verification)</b>	
<b>normal</b>	
The RGY-flashes alternately	System self-inspection
YG-flashing alternately	preheat
G-Slow flicker	The flying vehicle is in the GPS mode
<b>warn</b>	
Y-Slow flicker	The flying vehicle is in the ATTI mode
Y-fast blink	There is no connection between the aircraft and the remote control
R-Slow flicker	Low power warning
R-fast blink	Severe low power alert
R-Chang Liang	Serious problem or an IMU exception
RY-flashes alternately	The compass is abnormal, requiring calibration / magnetometer interference
<b>Compass calibration</b>	
Y-fast blink	Prepare for calibration of the compass / the aircraft is undergoing calibration
G-Chang Liang	Calibration was successful
The R-red color is always bright	Calibration failed

## 2. Controlled rotation range of the cloud head

The channel melt optical L10T has a high-precision three-axis motor structure, which keeps the camera stable when the aircraft flies, thus ensuring image stability and clarity. The controllable rotation angle of the three-axis motor is shown in Fig.

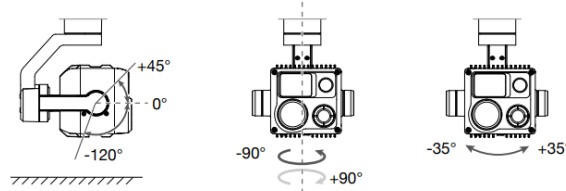

## 2.2.1 Cloud head working mode

<b>Increased stability mode</b>	<b>The roller shaft is kept horizontal, while the pitch shaft remains at a user-set angle. This mode is used to capture stable horizontal pictures and videos.</b>
---------------------------------	--

<b>FPV pattern</b>	The roller shaft is aligned with the rolling direction of the vehicle, while the elevation shaft is maintained at a user-specified angle. The pattern is used for the first-person perspective.
--------------------	---

### **important**

- In order to work normally, the cradle head temperature must be between -10 C and 50 C.
- The cradle head is fixed using a cradle head protection cover to protect the cradle head from accidental rotation and to avoid damage during storage.
- Remove the cradle head protection cover before startup. Otherwise, it may cause damage to the cradle head motor and electrical circuit.
- When the aircraft power switch is opened, the cradle will automatically rotate to perform self-test and calibration. Please make sure there are no objects near the PTZ.
- 

## 2.22 Remove / install the cloud head

The aircraft adopts a Yuntai removable design. For the disassembly steps, please see the following steps:

1. Place the vehicle on a horizontal surface to make the cradle head head up.
2. Use T6 screwdriver to remove two screws on the protective cover and remove the protective cover plate. With a cross. The screwdriver (model) shall unscrew the metal cover screws to fix the FPC connector and pull the connector wiring interface out from the slot.
3. Gently pinch the tail of the shock absorber (figure: mark the shock absorber). Slide straight up along the cradle tank. To install the cloud head, install the steps and please review the following steps:
  1. Pinch the tail of the shock absorber gently and lift the cradle head. Slide the cradle head in a straight line down the tank.

**! important:**

- Make sure that the rings at the front end of the cradle head are aligned with the two pins in the cradle head compartment of the nose.
- Please ensure that the grooves of the cradle head and the cradle head cabin are at level.

2. Place the connector wiring port in the slot, and push it to the bottom when inserted. Place the cloud head cover on top of the cloud head bay and retighten the metal cover screw fixing the FPC connector using a cross screwdriver.

3. Insert one screw into one hole in the protective cover of the head, screw it in using the T6 screwdriver until the screw is tightened to fix it. Repeat this step for another screw.

4. Turn on the power switch for the aircraft. If the cradle head connector cable is properly connected, the cradle head will automatically rotate for a self-test.

**! important:**

- After installing the head back to the aircraft, please ensure that each part is in a tight and fixed state to avoid losses caused by functional failure caused by the weak assembly of the head in flight.

## 2.3 Camera

The melt L10T integrates four sensor systems: telephoto camera, wide-angle camera, infrared thermal imaging camera and laser rangefinder. Combined with the leading multi-sensor fusion algorithm, it realizes visible 8k ultra HD resolution video recording, 10 x optical zoom, 640 \* 512 HD infrared thermal imaging and 1.2km laser ranging, enabling a variety of industrial application scenarios.

The camera supports a variety of camera modes, including: single shot, continuous shot, AEB, timing, HDR photo. The camera saves photos in DNG or JPG format and records video in MOV or MP4 format. Images and videos can be stored in the micro SD card or the vehicle's built-in memory.

### 2.3.1 Camera operation

Control the camera with the Autel EnterpriseApp built in the smart remote

control

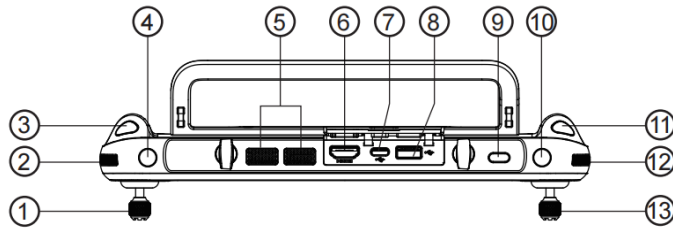

(Top view, with the following 6 keys indicated separately)

- Pitch wave wheel: adjust the pitch Angle of the head, dial clockwise, rotate up on the head, dial counterclockwise, and rotate down under the cloud
- Zoom wave wheel: dial to do the screen zoom, clockwise dial, increase the zoom multiple, counterclockwise dial, reduce the zoom multiple
- Photo button: short press to shoot
- Video recording button: short press to start / stop video recording
- Custom key C 1 / C2: you can quickly take a shooting function, and you can make an independent custom function setting in A utel E nterprise A pp

## 2.4 Flight control system

EVO Max 4T Stable and convenient flight control is implemented through its built-in intelligent flight control system. The system supports a number of advanced functions, including return, runaway protection, Starpoint positioning system, etc. The working description of each module is shown below.

Intelligent flight control system module	
module	description
IMU	A triaxial gyroscope and a triaxial accelerometer measure the acceleration and the angular velocity.
compass	Measure the geomagnetic field and provide the heading reference for the aircraft.
GNSS receiver	Receive global satellite navigation signals to determine the longitude, latitude, and altitude.

barometer	Measure the atmospheric pressure to determine the altitude of the aircraft.
ultrasonic sensor	Measure the distance between the vehicle and the ground.
Binocular visual perception system	Support forward vision, back vision, left, right, top, lower binocular vision to be confirmed.

#### .4.12 Flight mode

Depending on the GPS availability and flight conditions, the aircraft can automatically switch between the three flight modes.

airplane mode	description
GPS pattern	The GPS mode is activated when the vehicle detects the appropriate GNSS signal. With the assistance of the front view and lower visual system, GPS can locate and avoid obstacles, provide stable and smooth flight control, and support safety functions such as return flight and out of control protection.
ATTI pattern	The ATTI mode is activated when the GPS signal is weak and the light conditions cannot meet the visual system. The obstacle avoidance function is disabled, and the aircraft controls the altitude only through its barometer.
Starpoint pattern	In this mode, the aircraft works in the visual positioning mode, and there are requirements for the environment and height. The surrounding environment should ensure that the light is enough and the ground texture is clear, and the height of the UAV should be maintained, within the perception range of the visual system, and the aircraft will enter the ATTI mode beyond it.

#### .4.22 Acceleration mode (flight gear) switch

EVO Max 4T The aircraft supports a variety of acceleration modes, and users can switch the acceleration mode in Autel Enterprise App.

Flight gear	description
standard mode	to be confirmed

Furious mode	to be confirmed
--------------	-----------------

**warn:**

- If you are not familiar with the flight control of the aircraft, we do not recommend users to switch to rage mode
- When switching to rage mode, the aircraft's obstacle avoidance function will automatically turn off. During the flight process, the aircraft will not automatically avoid the surrounding obstacles. Please pay attention to the surrounding environment when using it, and manually control the aircraft to avoid the obstacles.
- When switching to the violent mode, the flight speed is greatly improved compared with the standard mode, so the braking distance in this mode will be extended accordingly. The user should maintain a braking distance of at least 50 meters when controlling the aircraft in this mode to ensure personal and flight safety.

### **Attitude mode**

When the aircraft is in an environment without GNSS signal or poor signal, the flight control system only maintains the stable attitude of the UAV, and the aircraft may drift due to the lack of accurate positioning.

**warn:**

- Avoid flying in the environment of poor GNSS satellite signal in the narrow, surrounding shelter environment (such as tunnels, dense buildings, etc.), so as to avoid weak GNSS signal, signal loss or visual system, resulting in the passive attitude mode of the aircraft, thus affecting the flight safety.
- In attitude mode, the aircraft is prone to external interference, and the aircraft is easy to drift in the horizontal direction, and does not have autonomous obstacle avoidance ability. The handling difficulty of the aircraft in the attitude mode will be greatly increased. Once the aircraft enters this mode passively, please land the operation as soon as possible, and land the aircraft to a safe position away from the crowd to avoid accidents.

### **2.4.3 Intelligent flight function**

- **Intelligent tracking**



Intelligent tracking uses deep learning algorithms to detect six types of objects in real time: pedestrians, cyclists, cars, trucks, boats, and animals. Real-time tracking algorithm is used to automatically track the selected objects while avoiding obstacles in flight. This feature tracks objects in three modes.

- **Point to the flight**

Pointing to flight allows the user to set the direction of the vehicle by touching a point on the screen.

- **gesture recognition**

The main camera uses deep learning algorithms to recognize and respond to three gesture commands: straighten your arms up to set yourself as a target, raise your arms flat to take a photo, and raise one arm to start or stop recording.

- **Precise landing**

Precision landing uses the binocular vision system below the aircraft to record information at its takeoff position. During the process of return flight and landing, the visual algorithm is used to calculate the position error of the aircraft and its takeoff point in real time, so as to control the precise landing of the aircraft at the take-off position.

- **Safe landing**

The safe landing function uses the lower visual system of the vehicle to create a density depth map. The flatness and angle of the depth map are then calculated to detect whether the surface is sufficiently flat to ensure a safe landing.

## **.52 Data storage / transmission**

### **.5.12 Use the microSD card**

Before opening the aircraft, insert a microSD card into the port, as shown in the figure below.

EVO Max 4T Maximum support capacity. The SD card for the GB (to be confirmed). If you plan to shoot HD video, we recommend using Class 10, UHS-3 microSD cards, or external SSD high-speed hard drives.

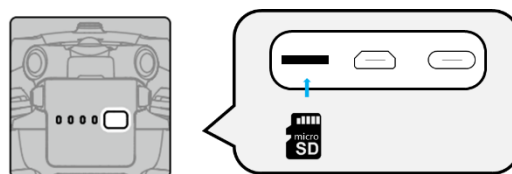

**⚠ warn**

- To prevent data loss, please turn off the aircraft before removing the microSD card.

### 5.22 Transfer the files to the P C/Mac

To transfer photos and video to the P C/Mac, connect the computer to the flying vehicle via the USB-C interface, as shown below.

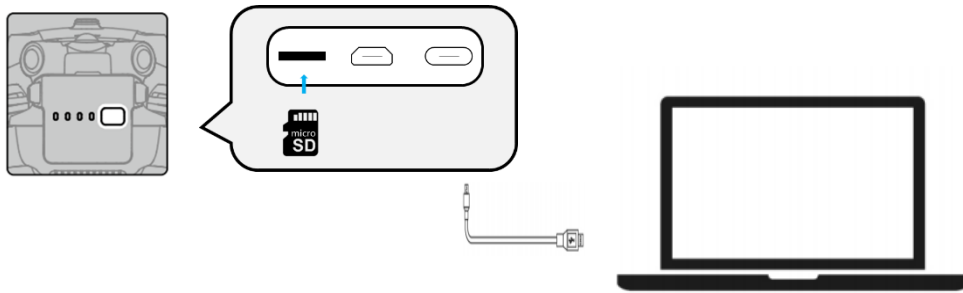

# Intelligent remote control

The function and use of the components of the intelligent remote control,  
and the control of the aircraft

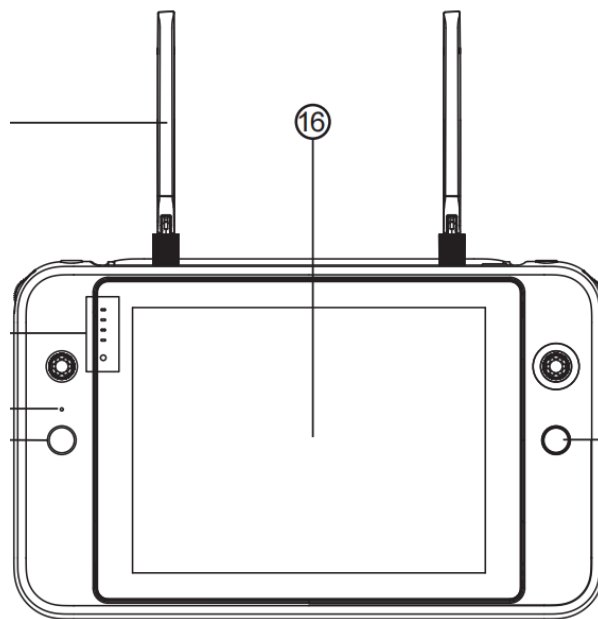

## Chapter 3: A utelIntelligent remote control

### 3.1 Product Introduction

The Autel intelligent remote control can be used with the aircraft supporting the device to transmit high-definition images in real time. With the complete function buttons of the remote control, the operation and setting of the aircraft and the camera can be completed within the maximum communication distance of 20 kilometers. The remote control has a built-in 7.9-inch 2048x1536 ultra ultra bright screen, with a maximum brightness of 2000 nit, which can still be clearly displayed in strong light. Built-in 128G memory, convenient and timely storage of aerial photography materials. The remote control lasts about 4.5 hours when the battery is full and 50% brightness

#### .13.1 Part introduction

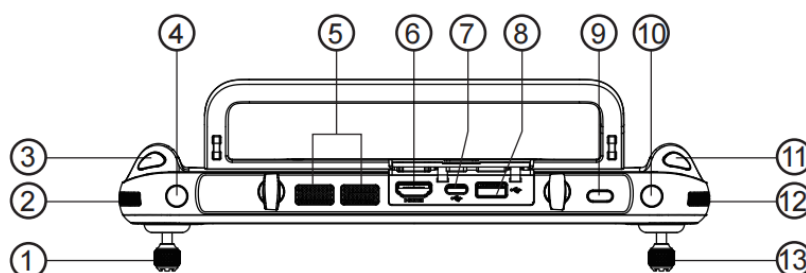

1	Left rocker	Default operation mode: control the lifting and heading of the aircraft (Joystick mode can be set at Autel Enterprise App)
2	Cloud platform pitch dial wheel	Move the wave wheel to adjust the pitch angle of the cradle head
3	record key	Tap to start / pause the recording video
4	Custom key C1	Use the Autel Enterprise App to customize the settings feature
5	air outlet	For remote control heat dissipation, please pay attention to whether there is a foreign body blocking the air outlet
6	HDMI joggle	Output the real-time picture of the intelligent remote control screen

7	USB-C joggle	For remote control charging or data transmission
8	The USB-A interface	Extended 4G / 5G modules or external USB devices for data transmission
9	Power button	Long press for 2s to open / close the remote control
10	Custom key C2	Use the Autel Enterprise App to customize the settings feature
11	Photo button	Tap it to take a photo
12	Zoom wheel	Drive the wave wheel to adjust the zoom multiple of the camera
13	Right rocker	Default operation mode: control the translation of the front / rear / left / right directions of the aircraft (Joystick mode can be set at Autel Enterprise App)

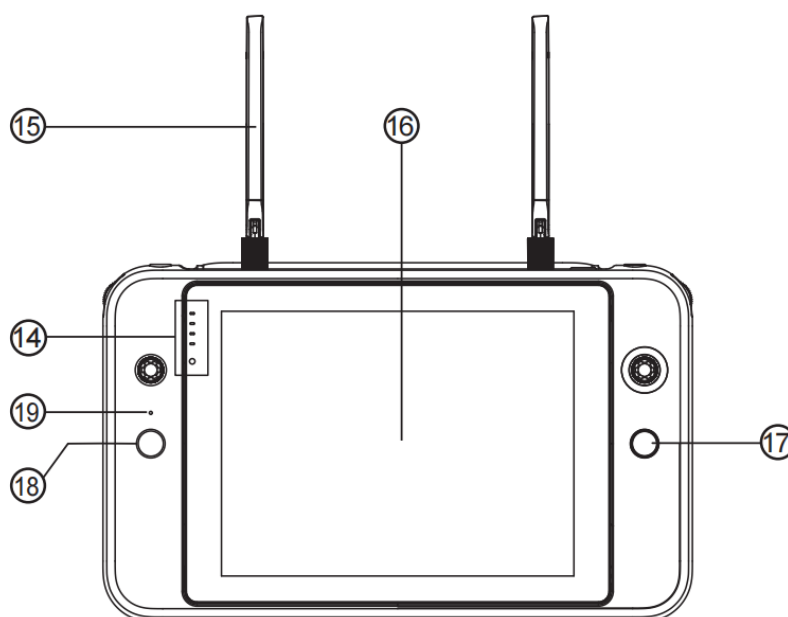

14	Power indicator light	Displays the remaining power of the remote control
15	antenna	Transfer the intelligent remote control controlsignal

		and the map transmission information of the aircraft
16	display screen	Display the picture transmission screen, and support the touch control operation
17	a pause button	Tap to control the vehicle to suspend the autonomous flight and hover in place, or resume the autonomous flight
18	Automatic take-off / return home button	Long press to start / cancel the one-key return function,
19	Pick up the sound hole	Receive external audio sources

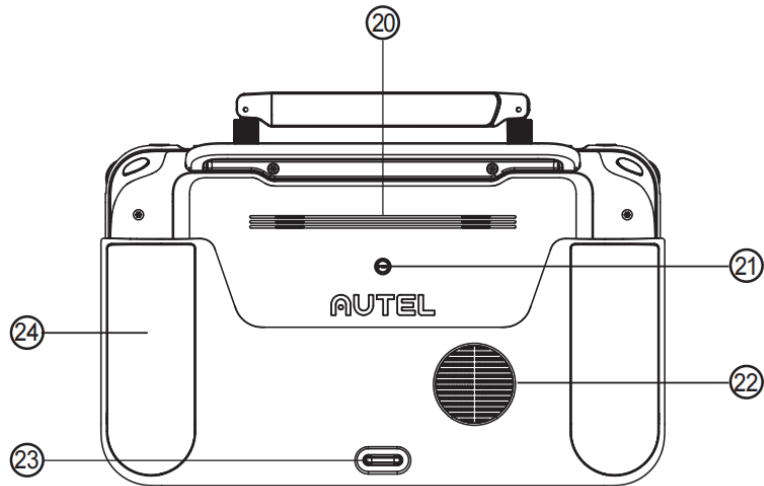

20	loudspeaker	The sound is played to indicate the aircraft status
21	Standard 1 / 4 interface	It is used to connect the scaffolding
22	air intake	For remote control heat dissipation, please pay attention to whether there is a foreign body blocking the air inlet
23	Under the hook	Fixed the remote control hanging strap
24	containment vessel	Prevent remote control collision, wear and other external damage
25	The rocker holds the threaded hole	For storing left and right rocker (mark required)

### 3.2 First-time use

#### . 1 Expand the remote control

The remote control is folded in the packing box. Expand the antenna before use.

#### . 2 Turn on the power supply

Long press the power button on the top of the smart to open the remote control.

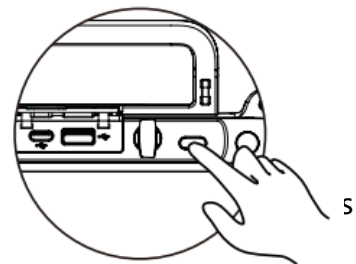

### . 3. Activate the intelligent remote control

When the smart remote control is used for the first time, it can be activated normally. When activated, the smart remote control should be kept in the networked state

Follow these steps to activate the vehicle

1. Make the remote control in the power-on state, and select the corresponding model.
2. Click on the avatar in the upper right corner of the Enterprise main page
3. register

#### remarks





- If the smart remote control cannot be activated successfully, check the network status of the connection. If the smart remote control cannot be activated several times, please contact the Smart Technology Support or the authorized dealer.
- When you log in to your Autel Robotics account, make sure the remote is connected to a network for data transfer.

### .2.13 Smart remote control power and charging

#### 1. Power quantity view

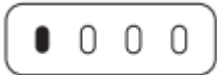
Short press the power button of the remote control, the power prompt light will display the power of the remote control, the power surplus is roughly as shown in the figure: (confirm the power light)

(Press the power key to match the map)

	
1 light: 0% -25%	2 lights are always on: 25% -50% of power
	
3 lights: 50% -75%	4 lights on: 75% -100%



💡 point out

The lock screen of the smart remote control, home interface or pull down the top status bar can view the current power.

## . 2 Equipment charging

- Use the dual-head USB-C data cable to connect the USB-C port at the top of the smart remote control, and connect the other end to the USB-C port of the power adapter, and connect to the AC power supply (100-240V).
- After the AC power supply is connected, the power prompt light of the intelligent remote control will start to flash in turn.
- It takes about 120 minutes for the smart charger to fully charge to the full charge

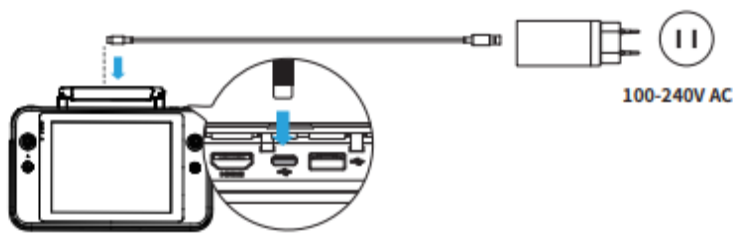

💡 point out

- Please charge with the official standard or certified charging device
- It is recommended to fully charge and discharge the smart remote control every three months to keep the battery in the best condition.
- Please use the official standard or certified smart charger and dual-head USB-C data cable, otherwise the charging rate may be affected.
- The charging environment temperature is different, but the charging rate is slightly different, and the actual charging time shall prevail.

## .2.33 Installation and use of accessories

### . 1 Install the remote control hanging belt

If using are strap, refer to the following installation steps

1. Cthe two metal clips on the strap to a narrow position on both side of the metal handle of the smart remote control.
2. After opening the metal button, bypass the lower hook at the bottom of the back of the smart remote control body, and then tighten the metal button.
3. After wearing the strap around the neck, the wearing mode as shown in the figure can reduce the holding pressure of the hand.

## . 2 rocker storage and installation

On the back of the intelligent remote control. When the joystick needs to be stored, rotate the screw from the body of the intelligent remote control, and align the bottom of the rocker at the screw hole, and rotate clockwise to the back handle. If you need to take out the installation, please take the opposite step. (Shaker-out drawing)

### 3.2.4 Adjust the antenna

Expand the remote control antenna and adjust the antenna position. Different antenna positions receive different signal intensities. When the antenna and the back of the remote control are 180° or 260° Angle, and the antenna plane is facing the aircraft, the signal quality of the remote control and the aircraft can reach the best state. When handling the aircraft, always keep the aircraft in the optimal communication range.

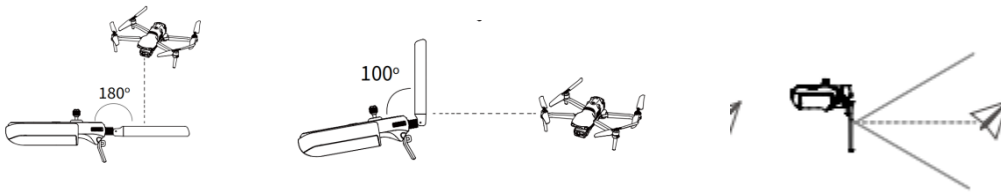

#### remarks

- Do not use other communication equipment in the same frequency band at the same time to avoid interference to the remote control signal.
- In practice, when the Autel E nterpriseApp is in the state of poor image transmission signal, the remote control terminal will prompt it. Adjust the antenna orientation according to the prompt to ensure that the aircraft is in the best data transmission range.

### 3.2.5 Frequency, calibration and joystick mode selection of intelligent remote control

#### 1. Frequency

- If you buy the intelligent remote control and aircraft packaged in the form of a package, you have set the intelligent remote control and the aircraft in advance when you leave the factory, no need to set again, and the equipment can be directly used after activation.
- For frequency operation using Autel Enterprise App, refer to the following specific steps for frequency operation:
  1. Short press on the aircraft fuselage. After the (position) opposite frequency button enters the opposite frequency state of the aircraft, the flight indicator light of the aircraft will be in the high-frequency flashing state (to be confirmed);
  2. Open the remote control and run Autel Enterprise App, enter the "intelligent Photography" interface, click the gear icon in the upper right corner, enter the Settings menu, click "Remote Control-> Remote Control to frequency> Main Remote Control to frequency", wait for a few seconds until the frequency matching is successful.

#### point out

- If the intelligent remote control and the aircraft are on frequency, please keep the distance between them within 50 cm







#### 2. calibration



If the smart remote control is used abnormally, it is recommended to calibrate the smart remote control. You can use the Autel Enterprise App to calibrate the rocker and keys, following the following steps:

- Open the remote control. Enter the App Camera Interface> Set (⚙️)> Remote> Remote Calibration. There will be two meter word shapes and two horizontal bars, representing the left and right joystick and the left and right dial wheel.
- Shaker calibration: Push and hold the joystick in eight directions until a beep is heard each time.
- Wheel calibration: Turn the dial wheel clockwise until a beep is heard, and then turn counterclockwise until a beep is heard.

### 3. Joystick mode

The joystick mode is divided into Japanese, American and Chinese hands. You can set the joystick mode in Autel EnterpriseApp according to your preferences. The default control mode of the remote control is the American Hand (Mode 2) mode (Please refer to the following below).

<b>Shaker mode American Hand (Mode 1)</b>	<b>aerobat regime of flight</b>	<b>Control mode</b>
<p>Left rocker (Do up and down)</p> 		<ul style="list-style-type: none"> <li>● The left rocker is the throttle rocker, which is used to control the vertical rise and fall of the aircraft.</li> <li>● Push up, the vehicle rises vertically; pull down, the vehicle drops vertically.</li> <li>● During the swing, the medium, the aircraft altitude remains unchanged.</li> <li>● When the aircraft takes off, please push the joystick up to above the median, and the aircraft can rise off the ground.</li> </ul>
<p>Left rocker (Do the left to the right action)</p> 		<ul style="list-style-type: none"> <li>● The left rocker is in the left and right direction, which is used to control the course of the aircraft</li> <li>● To the left, the vehicle rotates counterclockwise, and the vehicle rotates clockwise.</li> <li>● When the rocker returns, the rotation angle speed of the aircraft is zero, and the aircraft does not rotate.</li> <li>● The greater the swing rod quantity, the greater the rotation angle speed of the aircraft</li> </ul>
<p>Right rocker (Do up and down)</p> 		<ul style="list-style-type: none"> <li>● The right rocker is the pitch lever, which is used to control the front and rear direction of the aircraft</li> <li>● Push the rod up, the aircraft leans forward and flies in front of the nose; pull the lever down, the vehicle leans</li> </ul>

		<p>back and flies toward the tail of the vehicle.</p> <ul style="list-style-type: none"> <li>● When the rocker is back, the front and rear directions of the aircraft remain horizontal.</li> <li>● The larger the joker, the faster the flight, the greater the tilt.</li> </ul>
<p>Right rocker (Do the left to the right action)</p> 		<ul style="list-style-type: none"> <li>● The right and right direction of the right rocker is the roll bar, which is used to control the left and right direction of the aircraft</li> <li>● To the left, tilt the aircraft to the left and fly to the left, pull the rod to the right, tilt the aircraft to the right and fly to the right.</li> <li>● When the rocker is back, the front and rear directions of the aircraft remain horizontal.</li> <li>● The larger the joker, the faster the flight, the greater the tilt.</li> </ul>

#### 4. Shock mode description

When using the intelligent remote control for flight control, it is necessary to understand the flight control mode of the current joystick, and fly carefully. The joystick mode is Japanese, American and Chinese hands, as shown in the following figure:

##### Japanese Hand (Mode 1)

Left rocker: Push the joystick up and down to control the vehicle forward and backward movement; push it left or right to control the direction of the aircraft.

Right joystick: push the joystick up and down to control the rise and descent of the aircraft; push the joystick to the left or right to control the left or right movement.

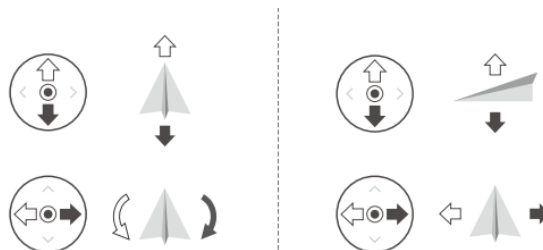

### American Hand (Mode 2)

- Left joystick: push the joystick up and down to control the rise and descent of the aircraft; push it left or right to control the heading of the aircraft.
- Right joystick: push the joystick up and down to control the forward and backward movement of the aircraft; push it left or right to control the yaw of the aircraft.

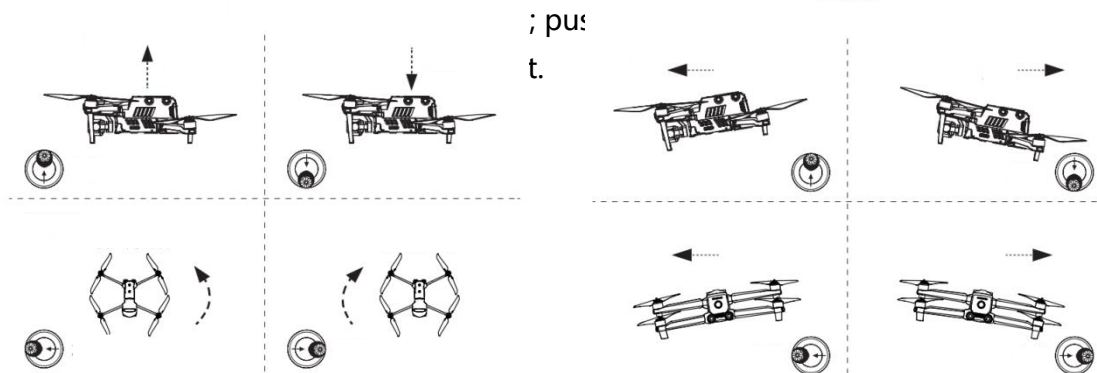

### Chinese hand (Mode 3)

- Left joystick: push the joystick up and down to control the forward and backward movement of the aircraft; push the joystick to the left or right to move the aircraft to the left or right.
- Right joystick: push the joystick up and down to control the rise and descent of the aircraft; push it left or right to control the heading of the aircraft.

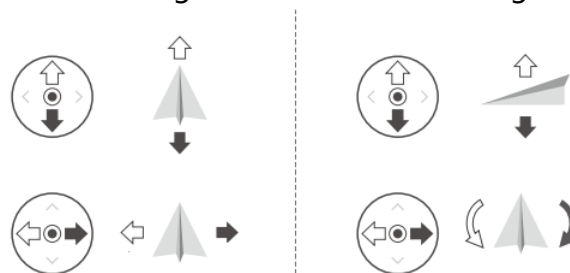

### 💡 point out

If you are the first time to operate the drone, please keep the lever gentle until familiar with the operation of the drone.

## .33 Key function

### .3.13 Automatic takeoff / return button, pause button

The return function is only enabled if the GNSS signal is good. To manually activate the automatic return function, press the return button ( ) on the remote control. Upon receiving the command, the aircraft will automatically return and land at the preset return point.

EVO Max 4T Its omnidirectional obstacle avoidance system can be used to detect and avoid the obstacles in the air route. When the aircraft is in the return state, the function of the remote control will be disabled, and you can short press the pause button ( ) to activate it again.

#### warn

- 2 If the forward vision system is not enabled during the return flight, the aircraft will be unable to automatically avoid obstacles. Press the pause button on the remote control Exit the automatic return function to regain control of the aircraft.

#### important

- 3 The default return altitude is 30 meters. If you activate the return function when the aircraft is below this altitude, the aircraft will rise to 30 meters before performing the return function.
- 4 If the automatic return function is activated within a 10-meter radius of the return point, the aircraft will automatically land in place.

### .3.23 Custom key C 1 / C2

Functional settings for custom key C 1 / C2 via Autel Enterprise A pp:

<b>OA obstacle avoidance on / off</b>	<b>Long press for 2 seconds to trigger: open / close the omnidirectional visual obstacle avoidance system. When the function is turned on, the aircraft will automatically hover when it detects the obstacle in the field of vision</b>
---------------------------------------	--

<b>AE lock / unlock</b>	
<b>Middle / 90°</b>	Long press for 2 seconds to trigger: switch the cloud head angle. The heading Angle returns from the current position to the same aircraft nose heading, while the pitch Angle returns from the current angle

	to the 0° direction; it returns from the current position to the same aircraft nose heading, and the pitch angle rotates from the current angle to the 90° direction.
<b>Map / FPV switching</b>	Long press for 2 seconds to trigger: switch the map mode / first person visual mode.
<b>Accelerated Mode standard / Fury</b>	Long press for 2 seconds to trigger: switch the acceleration mode of the aircraft, the standard mode can choose the speed of 5m / s, 10m / s, the rage mode can choose the speed of 15m / s, 20m / s.

 Warning: When violent mode is turned on, the visual obstacle avoidance system will be turned off. It is recommended to use the aircraft in an open area and operate with cautiously.



## 3.4 AutelSkyLink map transfer function

EVO Max 4T The aircraft is equipped with Autel SkyLink 2.0 map transmission technology, equipped with 2 map transmission antennas and 4 receiving signals, so that the communication distance between EVO Max 4T and the ground control terminal can reach / 20 km.

- It supports the adaptive frequency hopping transmission of multiplex frequency bands, and selects the optimal channel according to the electromagnetic interference situation, which has a strong anti-interference ability.
- The real-time transmission picture quality reaches 1080p / 60 fp, and it has the high transmission code rate and low time delay transmission characteristics of 64Mbps.
- The AES-256 encryption mode is adopted for the full-link data transmission and storage, to ensure that the end-to-end communication data is not monitored.

## 3.5 Equipment calibration

### 3.5.1, and the compass calibration

The compass is calibrated at the factory, without user calibration in normal conditions. If the compass displays an error message, the flight direction of the vehicle is inconsistent with the control input, or the flight site deviates too much from the calibration position, please calibrate it in the following steps.

1. Turn on the vehicle and remote control and run Autel Enterprise App> Smart Photography> Click Set . At the beginning of the calibration process, the aircraft tail LED light turns yellow and flashes.
2. Hold the vehicle and keep it horizontal, and then turn the vehicle until the vehicle tail LED light turns green.
3. Hold the aircraft and keep it in the vertical direction, nose down, and then turn the aircraft until the aircraft tail LED light turns green.
4. Hold the aircraft so that the nose is forward and side down, and then turn the aircraft until the aircraft tail LED light turns green.

#### warn

The compass is very sensitive to electromagnetic interference, causing compass errors and decreased flight quality. If the compass is not work properly after

calibration, the aircraft can be moved to another location to calibrate again.

important

- Choose an open, outdoor area.
- Keep away from all magnetic interference sources, such as magnets or concrete reinforcement. The proximity to the large structures may also affect the calibration results.
- Distance from the underground and overhead power transmission lines.
- Do not carry magnetic materials (such as keys or magnetic jewelry).
- Stay away from all electronic devices (e. g., mobile devices) that may interfere with calibration.

#### **remarks**

If the calibration fails, the LED light of the aircraft will turn red. Repeat the above procedure at this point.

### **3.5.2IMU calibration**

IMU needles are calibrated at the factory, no user calibration in normal conditions. If the acceleration and angular velocity of the vehicle are abnormal, calibrate the vehicle as described below.

1. Remove the blades and fold the arms to place the aircraft horizontally
2. Place the vehicle according to the Autel Enterprise App prompts, and keep the vehicle stationary

#### **remarks**

During the IMU calibration, the cloud head will not work.

### **3.6 Remote control prompt tone**

In some scenarios, the remote control will issue a prompt sound (such as boot, low remote control power, obstacle reminder, etc.). For prompt details, you can refer to the real-time screen prompt of the remote control. Users can turn off the voice broadcast and obstacle reminder sound by themselves, and the operation method is: intelligent photography-setting-general-voice broadcast / obstacle reminder sound.

## **3.7 Picture transmission and picture output**

The aircraft comes with a variety of image output mode, which can be wired transmission and wireless transmission.

### **3.7.1 HDMI interface**

The remote control is equipped with a H DMI interface. After connecting the HDMI interface and the remote control interface can be output to the display screen.

### **3.7.2 Live streaming function**

The remote control has a built-in live broadcast function, which supports the R TMP protocol. Users can fill in the R TMP address, screen display mode and live broadcast resolution on the function page. Operation method: Intelligent photography-Settings-Live streaming (this function is turned off by default)

# **Intelligent flight battery**

Use, storage and maintenance of intelligent flight battery, etc

## **Chapter 4: Intelligent flight battery**

### **.14 Product profile**

EVO Max 4T The rechargeable lithium polymer battery used has the characteristics of high energy density and large capacity. The battery needs to be charged with a dedicated charging device provided.

(Required copy)

### **.14.1 Part introduction**

## **.24 Battery use**

### **1. Install the aircraft battery**

1. Turn off the battery power switch before installing the battery.
2. Insert the battery into the battery compartment, as shown in the right picture. A click when the battery is in place.

### **2. Remove the aircraft battery**

- Turn off the power switch of the aircraft battery before removing the battery.
- Press the buckle on both sides of the battery to slowly extract the battery.

### **3. Turn on the battery**

Before installing the battery, make sure it is turned off. After installation, long press the power button for 3 seconds. The battery level indicator light displays the current battery level.

### **4. Turn off the battery**

Long press the power button for 3 seconds to turn off the battery. If the battery is mounted on the vehicle, LED1 and LED4 will flash 5 times to indicate a shutdown. After all battery level lights are off, remove the battery from the vehicle.

## **.2.14. Battery power view and charging**

### **1. Check battery power**

When the battery is off, short press the power button for 1 second to check the battery level. The LED will display the current battery levels, as follows:

Battery level indicator status (non-charging status)

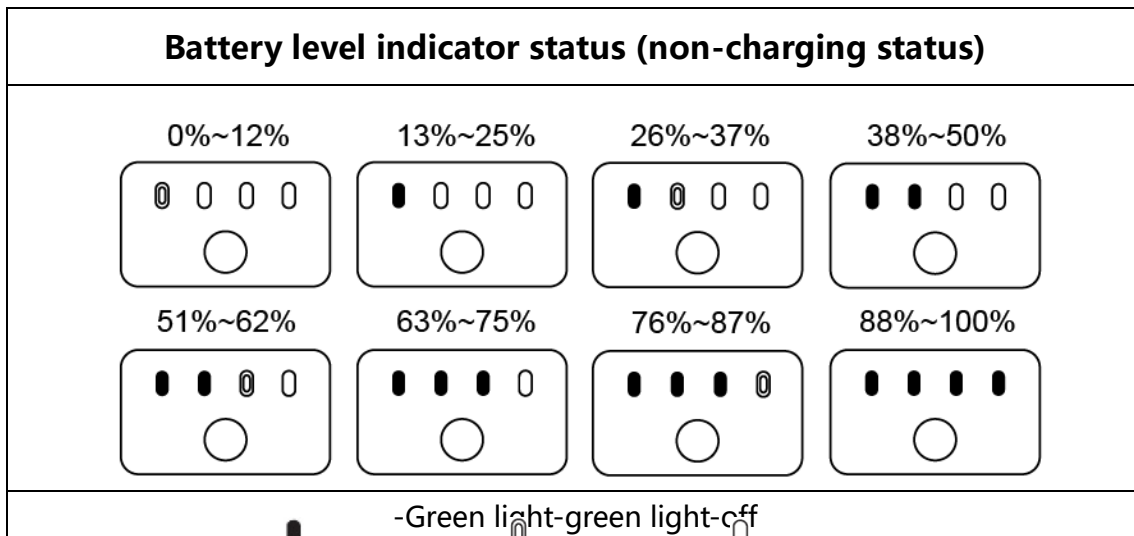

## 2. Battery charging

Connect the charging interface of the power adapter to the slot of the battery metal electrode, and connect the plug to the AC power supply (100-240V) to charge from 0 for up to 90 minutes, but the charging time is related to the remaining power.

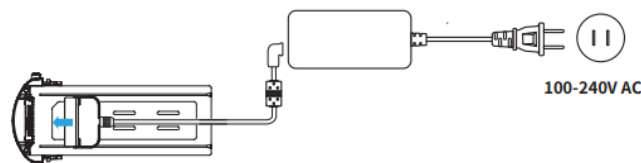

### point out

- The battery and charger provided by the official company must be used. It is forbidden to transform the battery pack and its charger, or to replace it with third-party equipment. Daotong Intelligence will not be responsible for all the consequences caused by charging the charging equipment provided by the official of Daotong Intelligence.
- When the charger is not used, it should be disconnected from the aircraft battery and power supply.
- Wait for the battery to cool to room temperature before charging. If the battery is connected to the charger immediately after the flight, the overtemperature protection function may be automatically activated, preventing the battery from charging until the battery is completely cooled.

## 3. Battery level indicator lamp:

The LED indicator on the aircraft battery is illuminated from left to right to indicate the current battery level during the charge cycle and turns off after the battery is fully charged.

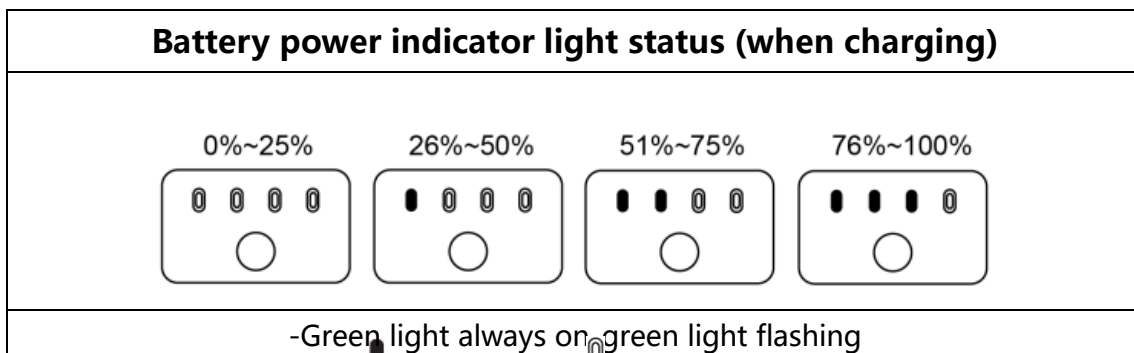

 **remarks**

- The aircraft and the remote control battery shall always be fully charged before the flight.
- The aircraft battery charge time is about 90 minutes and the remote control charge time is about 120 minutes.
- After charging, disconnect the charger from the aircraft battery / remote control.

## 4.3 Battery function

### 1. Battery thermal replacement

When the aircraft needs to replace the battery and the power supply is on, the original battery can be directly removed, and another fully charged battery can be replaced within 30 seconds.

### . 2 Battery self-heating

The battery has the self-heating function, at the low temperature environment:



- After inserting the aircraft and opening the battery, if the battery temperature is lower than 15°C, the self-heating function will be activated, and the self-heating function of the battery will be automatically turn off by the aircraft after take-off. Note that when the battery temperature is lower than-10°C, the aircraft will not be allowed to take off. It is recommended to operate until after the self-heating is over
- If the battery is not inserted into the aircraft, short press the power button, and then long press the power button for 3 seconds to activate the self-heating function, and the final battery temperature will be maintained

between 15°C and 20°C. The battery lasts about 30 minutes to keep warm. Press the power button long enough for 3 seconds to exit the battery self-heating function during the heating process.

- When the battery is heated and insulated, the battery power indicator light flashes as shown in the figure.(LED graphic)



## Warning instructions

Battery level indicator light status
<ol style="list-style-type: none"><li>1. LED1 and LED3 were flashed alternately in groups with LED2 and LED4, indicating ongoing heating.</li><li>2. 4 LED flash simultaneously, indicating the insulation state.</li></ol>
 -Green light  -green light  -off

### point out

1. When the ambient temperature of the battery is lower than 5°C, the battery will increase the internal resistance and the voltage drop due to the low temperature, which reduces the usable capacity of the battery, resulting in reducing the battery life time. Before using the battery, please fully use the battery, that is, the cell voltage will reach 14.88 V.
2. After meeting the above conditions, it is recommended to choose a suitable place for landing operation immediately when the Autel Enterprise A pp indicates serious low power. During the automatic landing process, the aircraft can still control the course through the remote control
3. In the extreme cold environment, even if the self-heating function is adopted, the battery temperature may still not reach the available temperature. Please add thermal insulation measures during the heating process.
4. In order to achieve the best performance of the battery, it is recommended to keep the battery temperature above 15°C to 20°C before flight
5. At low temperature, the self-heating time of the battery may be long. It is suggested that users keep the battery warm in advance to shorten the self-heating time.

## 4.4 Additional functions

- Low power protection

If the battery is low, the battery will automatically enter sleep mode in case of overdischarge. In this mode, the battery does not respond when pressing the power button. To wake up the battery, connect it to the charger.

- Charging temperature detection

If the charging temperature is below 5°C (41 °F) or above 45°C (113 °F), the battery will stop charging.

- Current protection

When the charging current is too large, the battery stops charging.

- Overcharge protection

Stop the charge automatically when the battery is fully charged.

- Balance protection

The voltage of each battery cell is balanced to prevent overcharging or overdischarge.

- Overdischarge protection

When the battery is not in use, the battery will automatically disconnect the power output function after the self-discharge cycle is completed. This feature is disabled during the flight.

- short-circuit protection

- -If Dan detects a short circuit, the power supply will be cut off.

- Power saving mode

If no operation for 30 minutes, the battery will be closed.

- communication















When used, the aircraft keeps synchronized with the battery to provide real-time information, including voltage, capacity, current, temperature, etc.

- Ultra-low energy consumption mode

When the battery is idle for 12 hours and the power level is less than 8%, the battery will enter the ultra-low power consumption mode to reduce the self-

consumption power level. When the ultra-low power consumption battery is restored, it needs to be activated with the charger before continuing to normal use.

- **Other battery level indicator light warning instructions**

LED 1	LED 2	LED 3	LED 4	Warning instructions
				Charging temperature is too high or too low.
				The charging current is too high and has caused a short circuit.
				Overcurrent, overload, or short-circuit problems occurred during the discharge.
 -The indicator light flashes  -turn it off				

## 4.5 Battery storage and disposal

### 1. Battery storage

Keep close contact with the water or heat source during storage. The battery shall be stored in a dry, well-ventilated area at room temperature (ideal temperature 22°C to 28°C (72 °F to 82 °F)).

#### point out

- Batteries should be stored in places out of reach of children and pets.
- Do not store batteries near direct sunlight or sharp objects, water, metals, or reactive chemicals.
- Storage of batteries at extreme temperatures shortens their service life. If the battery is not used for more than 1 day, it should be stored at -10°C (14 °F) to 30°C (86 °F) temperature. Otherwise, it may cause battery damage or failure.
- If idle for a long time, the battery life will be shortened.

### . 2 Storage for self-discharge protection

If the battery is stored in a high temperature environment or not used for 6 days and the power is high, the self-discharge protection will be activated. The battery will automatically discharge to a safe charge. This is the default setting, and the discharge process takes 2-3 days. Although the battery is not indicated during the self-discharge cycle, you can notice that the battery is slightly hot, which is normal. The discharge threshold can be customized using Autel Enterprise App (function to be determined).

#### 4. Battery disposal

- Be sure to completely discharge the battery before discarding it.
- Send the battery to the designated recycling point for proper disposal.

## **Autel Enterprise A pp**

Autel Enterprise A pp Software interface and function use



## Chapter 5: Autel Enterprise App

### Product profile

Autel Enterprise App is the flight control software developed by Daotong Intelligence for industry applications. The software integrates various professional functions to improve efficiency quickly and realize intelligent operation. With EVO Max 4T, it can be widely used in security, inspection and other industries. Users can choose various task modes such as navigation point task, rectangular task, polygon task, tilt photography and so on through Autel Enterprise App.

### 1. Navigation point mission

The user will add the navigation point by himself, set the parameters and actions of the aircraft at each point, and the point will be connected in order. After calling and execution, the aircraft will fly automatically according to the route and perform the corresponding action at each point.

Click "Mission Flight" on the main interface of the App, and select "Navigation Point Mission" to enter the planning interface.

Add the navigation point to the map, and set the corresponding parameters and actions of the vehicle at that point.

Flight altitude: the altitude of the aircraft flying at the flight point relative to the return point, and the aircraft will gradually adjust the flight altitude to the set value while flying to this flight point. Click Airpoint> Select "Flight altitude"> swipe around to change the value.

Flight speed: the flight speed of the aircraft when flying up to this point, and the aircraft will gradually adjust the flight speed to the set value during the process of flying to this point. Click "Airpoint"> select "Flight Speed"> swipe left and right to change the value.

Action: Click the point> Select "Action"> Set the point action and camera action. The point action is divided into "overfly" and "hover".

When choosing flyover, the camera can choose to take photos, take photos, range, start recording, stop recording or add action.

When hovering, the camera action can choose regular photography and video recording (1~10s).

Tay pitch Angle: the head pitch Angle (0°~90°). Click AirPoint> Select "Action"> Add Camera Action> Slide left and right to adjust the pitch angle.

Yaw angle: the nose orientation as the aircraft flies to the navigation point. Click Airpoint> Select Action> Add Camera Action> Select Yaw Mode.

Along the route: the aircraft turns to the next point at the set route.

Manual: The user controls the heading of the aircraft using the remote control.

Customization: The user can set the yaw angle for each navigation point.

latitude and longitude: adjust the longitude and latitude of the navigation point.

Related points of interest: The main purpose of the point of interest is to describe the address of things or events, such as banks, schools, hospitals and other geographical entities. Edit points of interest> Click on points of interest> associated navigation points.

## 2. Regional tasks

Users can choose three regional tasks (rectangular, polygonal, and tilt photography). The user can set the flight parameters of the aircraft, and the system will calculate and plan the flight path.

Click "Mission Flight" on the main interface of the App, and select the rectangular task, polygon task, or tilt photography to enter the planning interface.

Create a project, you can manually move, zoom in, and narrow the task area, and click the bottom menu to modify the parameters.

Rectangular task: Generate a rectangular flight area, and fly with the bow characters when the double grid is turned off, which is suitable for orthographic data acquisition. When opening the double grid, it is suitable for 3D modeling.

Polygon task: to generate the irregular polygon flight area, and to fly with the bow word when turning off the double grid, which is suitable for the orthographic image data acquisition. When opening the double grid, it is suitable for 3D modeling.

Tilt photography: The generated route consists of one normal route and four inclined routes, which are suitable for accurate 3D modeling.

	Rectangular task	Polygon task	oblique photograph
flight altitude	√	√	√
Slant height	√	√	√
ground resolution (GSD)	▲	▲	▲

Oblique ground resolution	x	x	▲
flight speed	√	√	√
Slant speed	x	x	√
The course overlap rate	√	√	√
Sloped heading overlap rate	x	x	√
Side-to-side overlap rate	√	√	√
Overlap rate of oblique radiation	x	x	√
Cloud platform pitch Angle	√	√	√
The tilting angle of the shower head	x	x	√
Return action	Return / hover	Return / hover	Return / hover
Main route Angle	√	√	√
Double grid	√	√	x
remarks	-Adjustable-Unadjustable ▲ -Values only are displayed, not adjustable		

### remarks

Course overlap rate: the overlap area rate of the ground of the adjacent images along the flight direction; the lateral overlap rate: the overlap rate between the two adjacent navigation belt photography zones. When the aircraft shoots at low altitude or shoots the surface of uniform areas (such as water surface, desert, field, vegetation, etc.), increasing the overlap rate is conducive to the image splicing and processing in the later stage.

Ground resolution: It describes the actual physical size of a pixel. The smaller the value, the clearer the image.



**! important**

If any of the following conditions are detected, the flight mission will automatically end, and the UAV will perform other operations based on the following conditions.

Battery shortage: App interface, a message will pop up, telling you that the aircraft will automatically return.

**Battery shortage: the aircraft will end the mission and automatically land in place.**

**The GPS signal strength is too weak: the drone will enter the ATTI mode and switch to manual control.**

### 3. Historical tasks

Users can name and save the flight missions, which are displayed in the order of time creation, the most recently saved tasks at the top of the list, and the earlier ones at the bottom. You can also find the corresponding historical task by searching the ( 🔍 ) file name.

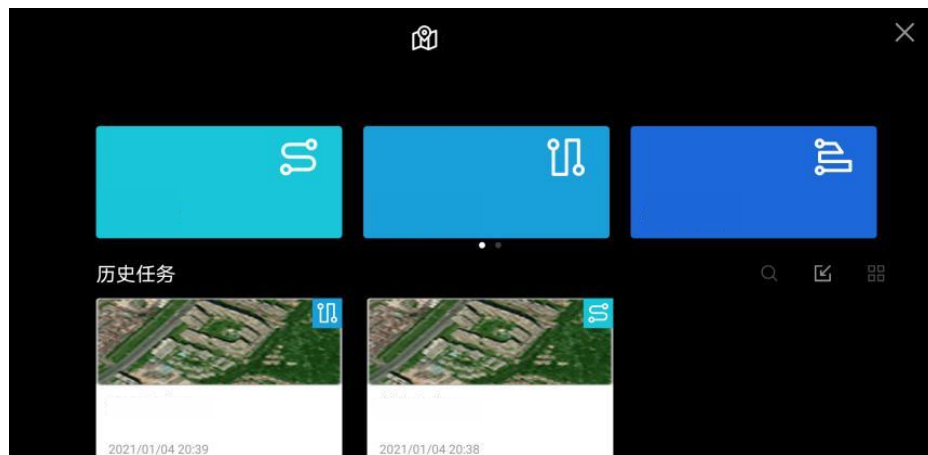

## Chapter 6: Firmware update and equipment maintenance

### 6.1 Firmware update

To achieve the most efficient state of EVO Max 4T performance, the aircraft and remote control can be upgraded to the latest firmware version to enhance the flight experience. Before flight, please confirm that the firmware of the aircraft, remote control and supporting products is the latest version.

#### 6.1.1 Firmware download and upgrade

- **Method 1: Autel Enterprise App Online upgrade**

1. Keep the aircraft and remote control on to ensure that the aircraft and remote control have completed frequency matching.
2. Open the Autel Enterprise App on the remote control side. If there is a new firmware update, the prompt box will automatically pop up in the software interface to remind you to download and install it.
3. Click to upgrade, Autel Enterprise App will download the latest firmware and automatically upgrade. When starting the upgrade automatically, you can view the upgrade process through the software interface.
4. After the upgrade, the aircraft and remote control will automatically restart and can be used after the restart.(Interaction logic needs confirmation)

- **Method 2: The official website firmware package is upgraded offline**

1. [Use P C/M ac to download the firmware upgrade package from the official website of Daotong Intelligence, visit: C/Mautelrobotics.cn/download/23.html, select the corresponding model to download.](#)

2. Insert the micro SD card into the PC / Mac, move the downloaded file to the root directory of the micro SD card, and then remove the micro SD card from the PC/Mac.

3. Insert the micro SD card into the vehicle and power on the vehicle.

4. If the aircraft checks the firmware in the micro SD card, the aircraft will be automatically upgraded. At this time, the front and rear indicator lights on the aircraft arm will quickly flash the green light alternately.

5. After the upgrade, the LED indicator of the aircraft arm will stop flashing.restart the remote control and aircraft can be used.(The flashing mode shall be confirmed)

### **! important**

Before performing a firmware update, make sure that:

- The aircraft is turned on and the motor is not started.
- Ensure that the battery level of the aircraft and the remote control is above 25% and that the remote control is normally connected to the network.
- The microSD card used by the aircraft has sufficient storage space to save the firmware upgrade package file.
- The firmware update process generally lasts approximately 15 minutes (depending on the network condition to which the remote control is connected). During the update process, please keep the network connection normal, do not turn off the aircraft or the remote control, do not remove the micro SD card from the aircraft during the upgrading, so as to avoid the upgrade failure.
- After the upgrade, the remote control may be disconnected from the aircraft.

## **6.2 Product maintenance and maintenance**

To ensure that EVO Max 4T maintains optimal performance, read and follow the maintenance instructions in this section.

### **6.2.1 Product maintenance**

- Please keep the camera away from liquid contact or immersion. If the camera enters water, use a soft dry cloth and place it in a relatively dry environment.
- When the aircraft accidentally falls into the water, do not turn on the power supply immediately. This behavior will cause permanent damage to the aircraft; do not store the aircraft in a high humidity place.
- Do not use a liquid containing volatile, ethanol and other volatile components to clean the camera lens, body visual sensor, infrared sensor lens, and the surface of the fill light.
- Daotong Intelligence recommends that you regularly check the various components of the aircraft and related products to see if there have been a strong impact, causing loosening, abnormal sound, or failure to function properly. If you have any questions, please take the A utel R obotics technical support personnel or authorized dealer.
- If you need to store or transport the aircraft for a long time, please ensure that the cradle head protection cover is firmly installed, the propeller is removed, the arm is folded, and accurately, the aircraft and related products are stored into the slot inside the industrial box to prevent damage to the internal electronic components, cameras, sensors and other components.

## 6.2.2 Storage and maintenance

After any collision or extrusion of the aircraft, each part of the aircraft should be carefully checked. Store aircraft and accessories out of children and pets.

- Store the aircraft and its accessories in a cool, dry place.
- Ensure that the aircraft is kept away from too humid and hot storage environments.
- The recommended storage temperature for the aircraft is 22 C to 28 C (72 F to 82 F)

## 6.3 Warranty policy

Dotong Intelligence (Autel Robotics) promises to users who purchase products from its official authorized channels that under normal use, the dotong Intelligence (Autel Robotics) products you buy have no defects in materials and process during the warranty period. The warranty period of this product starts from the date after you receive the goods. If you cannot provide valid evidence such as the purchase invoice, the warranty start date will be extended 90 days by the factory date shown by the machine or defined by Daotong Intelligence (Autel Robotics).

### **important**

[For the after-sales policy of products, please visit: http://www.autelrobotics.cn/page/policy.html](http://www.autelrobotics.cn/page/policy.html)

## 6.4 Customer service

This section contains information on technical support, repair services, request replacement or optional parts.

### 6.4.1 Customer Support

If you have any questions or concerns about our product, please contact Daotong Intelligent Customer Support:

China

Tel.: 400-800-1866

[website:www.autelrobotics.cn](http://www.autelrobotics.cn)

And North America / Europe

Tel.: (844) 692-8835

[Email: support@autelrobotics.com](mailto:support@autelrobotics.com) / [support.eu@autelrobotics.com](mailto:support.eu@autelrobotics.com)

[website:www.autelrobotics.com](http://www.autelrobotics.com)

## 6.4.2 Maintenance and service

If your equipment needs inspection or repair, contact DaolIntelligence in the following ways:

- [Send an email to after-sale@autelrobotics.com](mailto:after-sale@autelrobotics.com)
- Call the following number for intelligent technical support: 400-800-1866.
- Contact your authorized dealer.

### **remarks**

All data saved for the product that may be erased during maintenance. To avoid data loss, back up the file contents in your aircraft or remote before the product warranty.

## Chapter 7: Appendix

### 7.1 Specifications

<b>aerobat</b>	
takeoff weight	1500g (including battery and cradle)
Dimensions (length * width * height)	576 * 660 * 149 (spread with blade) 257 * 136 * 133 (folded without blade)
wheel base	464mm
Maximum flight time (no wind environment)	42 Minutes
Maximum hover time (no wind environment)	40 Minutes
Maximum horizontal flight speed (No wind environment)	22m/s
Maximum rate of rise	8m/s
Maximum rate of decline	6m/s
Maximum fly altitude of	121.92m (Restricted by GPS)
Maximum wind resistance grade	Level 8 Wind resistance speed is 20 m/s
IP grade	IP43
Maximum tiltable angle	35°
Maximum rotational angular speed	maximum rotative speed Pitch for 300° Yaw 180°
operating temperature range	-20°C ~ +50°C
service frequency	902-928MHz (FCC) 2.400-2.4835GHz 5.150-5.250GHz

	<p>5.725-5.850GHz (Other than Japan)  5.650-5.755GHz (Japan)  Radar: 60-64GHz(CE), 60-64 GHz(FCC) , 60-61GHz(MIC)  ADS-B: 1090MHz(RX)  GPS L1 C/A, BDS B1I, Galileo E1, GLONASS G1:  1559-1610MHz(RX)  Galileo E5a, Galileo E5b, GPS L5:  1164MHz-1215MHz(RX)</p>
through-put power	<p>@SRD 2.4G FCC: 26.51 dBm  @WLAN 2.4G FCC: 26.65dBm  @SRD 5.2G FCC: 20.03dBm  @WLAN 5.2G FCC: 17.81dBm  @SRD 5.8G FCC: 24.65dBm  @WLAN 5.8G FCC: 16.01dBm  @900MHz FCC: 28.97dBm  @ Radar: 18.14 dBm</p> <p>CE: ≤20dBm@2.4G, ≤23dBm@5.2G, ≤14dBm@5.8G  ≤13dBm@Radar  SRRC: ≤20dBm@2.4G, ≤33dBm@5.8G/5.7G</p>
Hover accuracy (light breeze or no wind)	<p>perpendicular:  ± 0.1 m (when the visual positioning is working normally);  ± 0.3 m (when the GPS is working normally);  ± 0.15 m (when the RTK positioning is working normally);  horizontal:  ± 0.15 m (when the visual positioning is working normally);  ± 0.3 m (when the GPS is working normally);</p>
On-board storage	64GB
SD card storage	512GB

<b>Cloud Terrace</b>	
Mechanical range	Proversion: -135° to 45° Roll: -45° to 45° Course: -45° to 45°
Controlled rotation range	Proversion: -90° to 30°
stabilization system	3-axis mechanical cradle (pitch, rolling, translation)
Maximum control rotational speed (pitch)	200°/s
The amount of Angle jitter	<0.005°



<b>Zoom camera (long focus)</b>	
image sensor	1 / 2 inch CMOS
Effective pixel	Effective pixels are 48 million, 12.5 million at night
camera lens	Focal length: 11.8-43.3mm 35mm equivalent focal length: 64-234mm f2.8-f4.8
exposure compensation	±3EV 0.3EV/step
ISO scope	Automatic: ISO100 ~ ISO6400 hand movement: Take photos: ISO100 ~ ISO6400 Video recording: ISO100 ~ ISO32000
shutter speed	Auto keep off: Photo mode: 1 / 8000-1 / 2s Video recording mode: 1 / 8000-1 / 30s M keep off: Photo mode: 1 / 8000-8s Video recording mode: 1 / 8000-1 / 30s
Maximum photo size	8192x6144
Maximum video resolution	7680x4320

<b>Wide Angle camera</b>	
image sensor	1 / 1.28-inch CMOS effective pixel 50 million night 12.5 million
camera lens	DFOV: 85° Foclength: 4.5 mm (equivalent: 23 mm) Aperture: f / 1.9 AF motor: 8-wire SMA, PDAF AF
exposure compensation	±3EV 0.3EV/step
ISO scope	Automatic: ISO100 ~ ISO6400 Manual: ISO100 ~ ISO6400 Take photos: ISO100 ~ ISO12800

	Video recording: ISO100 ~ ISO64000
shutter speed	Auto keep off: Photo mode: 1 / 8000-1 / 2s Video recording mode: 1 / 8000-1 / 30s M keep off: Photo mode: 1 / 8000-8s Video recording mode: 1 / 8000-1 / 30s
Maximum video resolution	7680×4320
Photo size	8192*6144 4096*3072

<b>Thermal imaging camera</b>	
image sensor	Uncooled vanadium oxide coke plane
camera lens	DFOV:42° Focal length: 13mm Aperture: f / 1.2
Infrared temperature measurement accuracy	± 3°C or ± 3% of the reading (take the larger) @ ambient temperature Degree-20°C to 60°C
Video resolution	640*512
Photo size	640*512
Like yuan spacing	
Temperature measurement mode	Central temperature measurement / pointing temperature measurement / single rectangular frame temperature measurement
Temperature measurement range	-20°C ~ +150°C, 0~+550°C
high temperature alert	High and low temperature alarm threshold value, report the coordinate and temperature value
palette	White hot / cold / rainbow / enhanced rainbow / iron red / lava / Aurora / burning / gradient /

	thermal detection
--	-------------------

<b>laser distance measuring instrument</b>	
wavelength	905nm
certainty of measurement	± 1m
measuring range	5-1200m

<b>Figure pass</b>	
service frequency	Support for the 2.4G/5.2G/5.8G/other
Maximum signal effective distance (No interference, no occlusion)	20km
Map maximum signal effective distance (Interference)	Strong interference (dense buildings, residential areas, etc.): 1.5-4 km (FCC/CE/SRRC/MIC) Middle Interference (suburban counties, urban parks, etc.): 3-10 km (FCC) ; 3-7 km (CE/SRRC/MIC) Weak disturbance (outer suburban wilderness, open farmland, etc.): 9-16 km (FCC) ; 6-9 km (CE/SRRC/MIC)
Independent networking	A 7.9-inch remote control
equivalent isotropically radiated power (EIRP)	2.4GHz: <33dBm (FCC) , <20dBm(CE/SRRC/MIC) 5.8GHz: <33dBm(FCC), <30dBm(SRRC), <14dBm(CE) 5.15-5.25GHz: < 23dBm(FCC/SRRC/MIC)

<b>Autel, smart remote control V3</b>	
Maximum signal effective distance (no interference, no occlusion)	20km (FCC), 7km (CE)
* service frequency	902-928MHz (FCC) 2.400-2.4835GHz 5.725-5.850GHz (Other than Japan) 5.650-5.755GHz (Japan)
through-put power	FCC: ≤33dBm CE: ≤20dBm@2.4G, ≤14dBm@5.8G SRRC: ≤20dBm@2.4G, ≤33dBm@5.8G/5.7G
dedicated space	Built-in, at 128GB
Video output interface	HDMI
cell	capacity:5800mAh Voltage: 11.55V type:Li-po Energy: 67Wh Charging time: 120 minutes
duration of flight	3 hours (maximum brightness) 4.5 hours (50% luminance)
operating ambient temperature	-20°C ~ 40°C
size	30319087mm (antenna folding) 30327387mm (antenna deployed)
weight	1150g (no protective shell) 1250g (with protective shell)
Satellite positioning module	GPS/GLONASS/Galileo /B eiDou

<b>cell</b>	
battery capacity	8070mAh
voltage	14.88V

Battery type	LiPo 4S
energy content of battery	120wh
net weight	520g
Charging environment temperature	From 5 C to 45 C
Storage of ambient temperature & humidity	
Ideal storage temperature	
Maximum charging power	247W
charging interval	90 Minutes
Hot replacement	support

<b>charger</b>	
import	100-240 V、 50/60 Hz、 3.0A
output	Main output: 17 V = 7.06A USB-C :30W 5.0 V =3.0 A 9.0 V =3.0 A/12.0 V =2.5A
voltage	17V
power rating	120W
Charging temperature range	From 5°C to 45°C

pour:

\* Working frequency band varies according to the country and region.

**FCC Caution:**

Any Changes or modifications not expressly approved by the party responsible for compliance could void the user's authority to operate the equipment.

This device complies with part 15 of the FCC Rules. Operation is subject to the following two conditions: (1) This device may not cause harmful interference, and (2) this device must accept any interference received, including interference that may cause undesired operation.

**IMPORTANT NOTE:**

Note: This equipment has been tested and found to comply with the limits for a Class B digital device, pursuant to part 15 of the FCC Rules. These limits are designed to provide reasonable protection against harmful interference in a residential installation. This equipment generates, uses and can radiate radio frequency energy and, if not installed and used in accordance with the instructions, may cause harmful interference to radio communications. However, there is no guarantee that interference will not occur in a particular installation. If this equipment does cause harmful interference to radio or television reception, which can be determined by turning the equipment off and on, the user is encouraged to try to correct the interference by one or more of the following measures:

—Reorient or relocate the receiving antenna.

—Increase the separation between the equipment and receiver.

—Connect the equipment into an outlet on a circuit different from that to which the receiver is connected.

—Consult the dealer or an experienced radio/TV technician for help.

**FCC Radiation Exposure Statement:**

This equipment complies with FCC radiation exposure limits set forth for an uncontrolled environment. This equipment should be installed and operated with minimum distance 20cm between the radiator & your body.

## **ISED Warning**

This device complies with Innovation, Science, and Economic Development Canada licence-exempt RSS standard(s). Operation is subject to the following two conditions:

- (1) this device may not cause interference, and
- (2) this device must accept any interference, including interference that may cause undesired operation of the device.

Le présent appareil est conforme aux CNR d'Innovation, Sciences et Développement économique Canada applicables aux appareils radio exempts de licence. L'exploitation est autorisée aux deux conditions suivantes :

- (1) l'appareil ne doit pas produire de brouillage, et
- (2) l'utilisateur de l'appareil doit accepter tout brouillage radioélectrique subi, même si le brouillage est susceptible d'en compromettre le fonctionnement.

The device is compliance with RF exposure guidelines, users can obtain Canadian information on RF exposure and compliance. The minimum distance from body to use the device is 20cm.

Le présent appareil est conforme. Après examen de ce matériel aux conformité ou aux limites d'intensité de champ RF, les utilisateurs peuvent sur l'exposition aux radiofréquences et la conformité and compliance d'acquiescer les informations correspondantes. La distance minimale du corps à utiliser le dispositif est de 20cm.