

# **EVO II Mobile Station**

## **Quick Guide**

### **Model: MDCMS-2**

#### **Disclaimer**

To ensure safe and successful operation of your base station, please strictly follow the operating instructions and steps in this manual.

If the user does not abide by the safety operation instructions, DTO Smart will not be responsible for any product damage or loss during use-whether direct or indirect, legal, special, accident or economic loss (including but not limited to loss of profit)-Provide warranty service. Do not use incompatible parts or use any method that does not comply with the official instructions of Autel Smart to modify the product.

The safety guidelines in this manual will be updated from time to time. To ensure that you get the latest version, please visit [www.autel drones.com/support/downloads/](http://www.autel drones.com/support/downloads/)

#### **battery safety**

EVO II base preclude the use of lithium polymer batteries. Improper use of lithium polymer batteries can be dangerous. Please ensure that all the following battery usage, charging and storage guidelines are strictly followed.

#### **Warning**

- Only use the battery and charger provided by DTO Smart. It is prohibited to modify the battery pack and its charger, or use third-party equipment to replace it.
- The electrolyte in the battery is extremely corrosive. If the electrolyte accidentally spills into your eyes or skin, please wash the affected area with clean water immediately and seek medical attention.

#### **Precautions**

1. According to local radio regulations, use base stations with corresponding frequency bands and comply with local radio laws and regulations.
2. Do not excessively bend and fold the wire during installation.
3. When installing and placing, make sure that the base station is level with the horizontal plane.



4. Use the base station in an open environment free from radio interference. Be sure to turn off other wireless devices in the same frequency band before using it.
5. Please make sure that the antennas of all devices are not blocked during use.
6. Use original accessories or accessories certified by Autel. The use of non-original accessories may cause danger to the safe use of the system.
7. Make sure that no foreign objects (such as water, oil and other liquids, sand, etc.) enter the parts.
8. Do not remove any parts installed at the factory by yourself.
9. When using in rain or snow, please take necessary waterproof measures for the base station. Please use caution in thunder and lightning weather and pay attention to lightning protection.

## Introduction



EVO II GNSS base station (hereinafter referred to as "base station") is a high-precision satellite signal receiver that supports 11-frequency GPS, Beidou, Galileo and GLONASS navigation systems<sup>1</sup> satellite signal reception of, as well as built-in carefully tuned data transmission. The system is convenient for users to use in different application environments.

EVO II GNSS base station as **RTK base station**, so that the positioning accuracy EVO II centimeter, but also provides a powerful magnetic immunity, protection and reliable flight operations at ambient power lines, metal construction and other magnetic interference.

## Item list

serial number	picture	name	quantity
1		base station (including base station cover)	1 PCS
2		multi-function charger	1 PCS

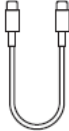
---

3		TYPE-C charging cable	1 PCS
4		Document (Quick Guide)	1

### component description

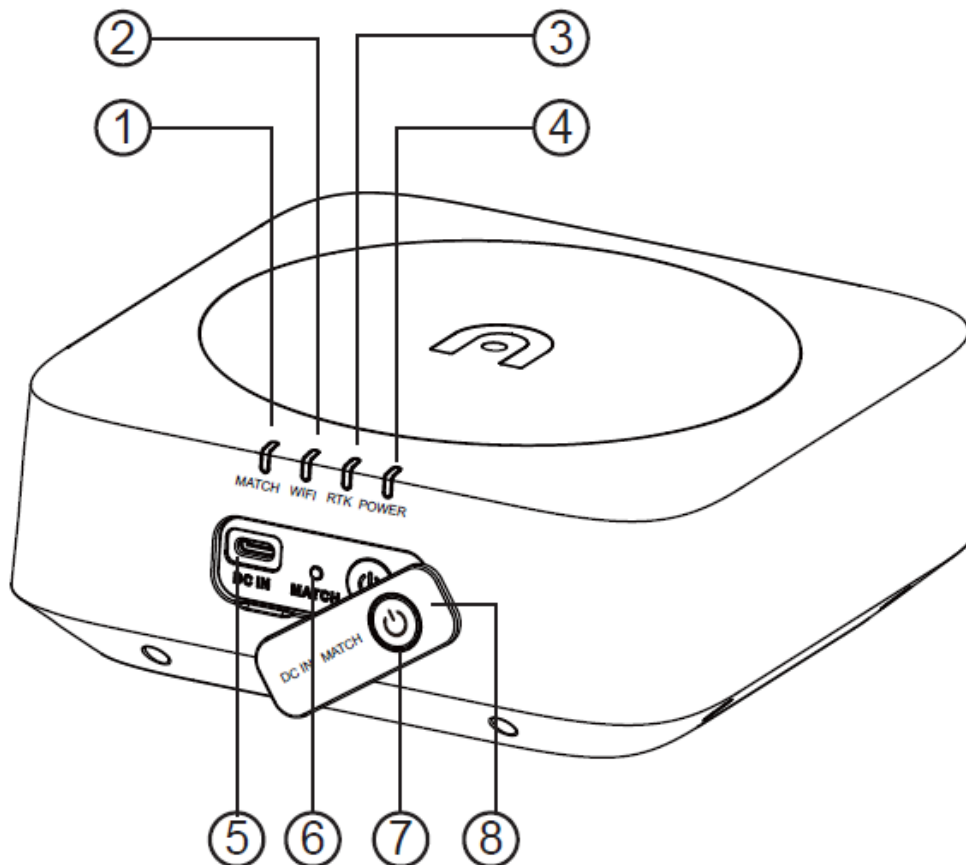

### base station body

- 2. WiFi indicator
- 3. RTK indicator
- 4. Power indicator
- 5. USB-C charging port
- 7. Power button
- 8 Port cover

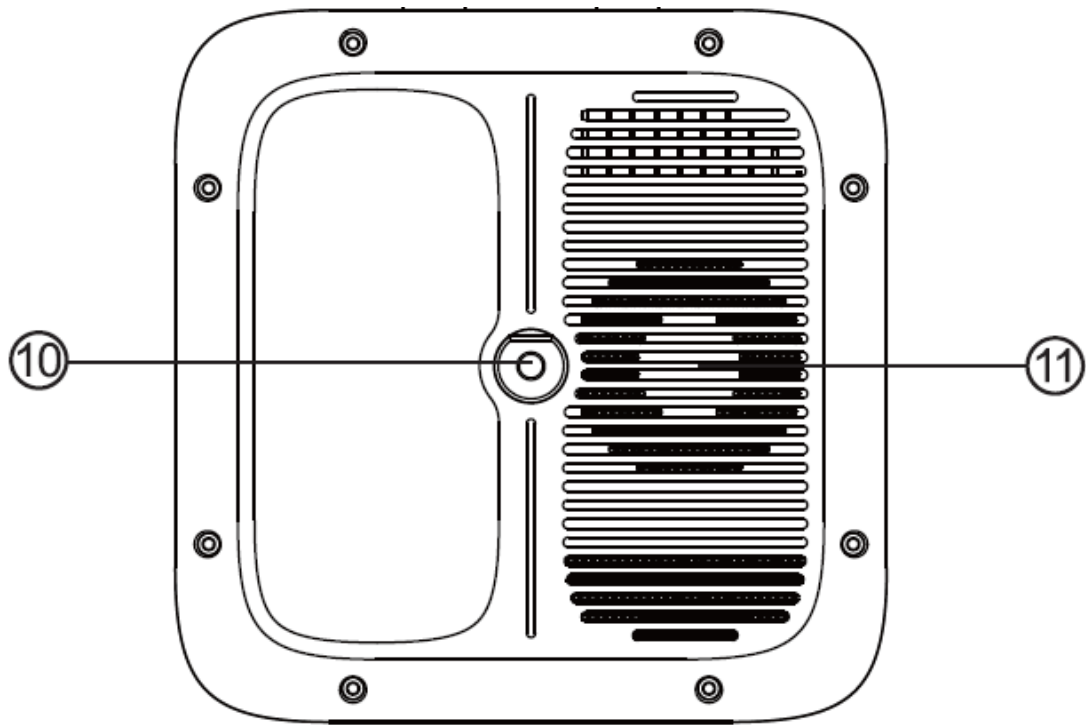

10. Turntable mounting hole

11. Heat sink

**tripod**

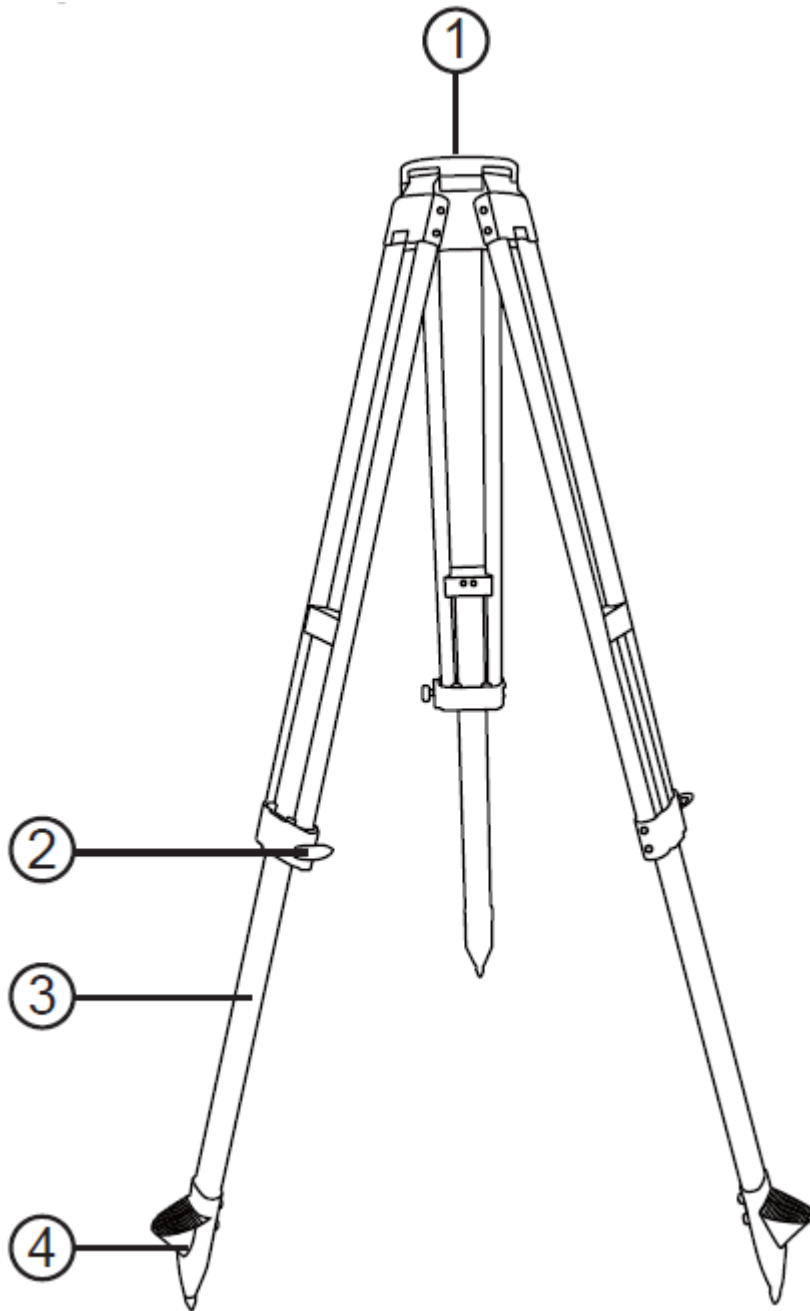

1. Fixing screw
2. Knob
3. Telescopic pole
4. Foot nail

**ready for  
charging**

Short press (<1 second) the power button once to check the battery level.

**Description of power indicator**

Green: Electricity > 60%

Yellow: Electricity > 30%

Red: Electricity > 10%

Red flashing slowly: Electricity < 10%

### **charging method**

When using the for the first time, be sure to fully charge the battery. Please use a dedicated charger to charge the base station.

- 1、 Plug the Type-C power cord into the Type-C port of the base station, and the base station will automatically enter the charging mode (either when it is turned on or off).
- 2、 When charging, the base station power indicator light flashes, and the battery power is indicated by different colors. When connected to a charging power source, the base station power indicator light is steady green to indicate that it is fully charged.

### **Turn on/off the base station**

#### **Turn on**

The base station has 2 working modes, namely normal mode and disabled RTK mode, which can be used in different operating scenarios. Follow the instructions below to turn on the base station and enter different working modes.

1. When the base station is off, press and hold the power button for 1 second to enter the normal mode.
2. When the base station is off, press and hold the power button for 3 seconds to enter the disabled RTK mode. When entering, the buzzer will beep 3 times and the RTK indicator will be steady red.

#### **Turn off**

Long press the power button for 1 second to turn off the

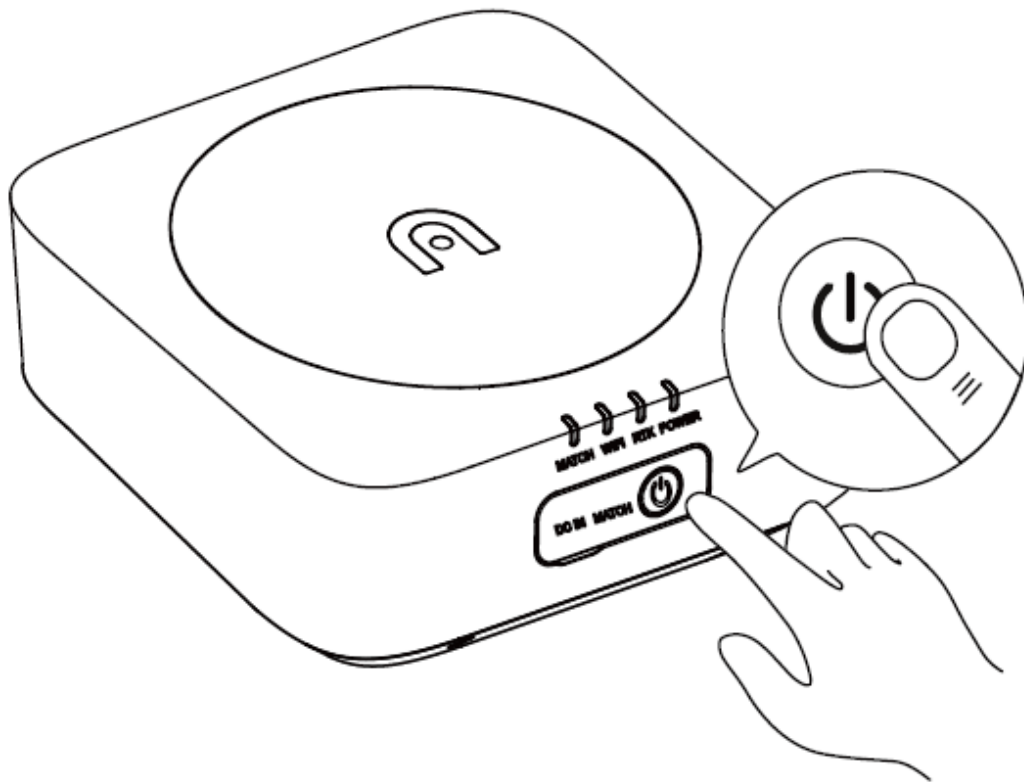

### **RTK indicator light Description**

Green: Number of satellites > 16, good signal (normal flight)

Yellow: Number of satellites 6-15, poor signal (it is recommended to adjust the base station to an open area)

Red Slow flashing: number of satellites < 6, poor signal (recommend the base station to be placed in an open area)

Light off: no RTK signal (indoors or abnormal base station RTK)

### **use to**

**connect to a ground station or aircraft**

#### **connection method**

Take the normal mode as an example, the specific operation is as follows.

#### **Connect the ground station to the base station**

- 1、 turn on the power of the station;
- 2、 turn on the remote control and run the Autel Voyager App, select "Settings -> Base Station", you can see the base station wifi hotspot after entering, enter the password: 12345678, wait a few seconds until the remote control is successfully connected to the base station;;
- 3、 exit Setting interface, enter the mission flight interface, click the gear icon in the upper right corner, enter the settings menu, click "remote control", and turn on

the "use base station connection" option.

### **EVO II GNSS base station is**

Choose a place with a wide view to set up the EVO II GNSS base station and mark it (align the center of the tripod with the center of the mark point) so that the base station can be accurately reset after being moved.

1. Open the tripod, stretch the three telescopic rods to a suitable length, and then tighten the knob to ensure that the tripod is stable.
2. Install the base station body to the tripod and tighten the lock nut on the body. Ensure that the base station is level and stable.

### **Note:**

- After the tripod is leveled, do not change the position and angle of the tripod or base station, otherwise you need to level it again.
- The installation environment of the base station requires a wide field of vision, and ensure that there are no obstacles (trees, buildings) above 15° around the base station antenna to avoid GNSS signals from being absorbed or blocked.
- The installation environment of the base station should be at least 200 m away from high-power radio sources (such as TV stations, microwave stations, etc.), and at least 50 m away from high-voltage transmission lines to avoid electromagnetic field interference to GNSS signals.
- There should be no large area of water or objects that strongly interfere with satellite signal reception near the environment where the base station is installed, in order to reduce the impact of multipath effects.
- During the mission of the aircraft, the base station must not be moved, otherwise it may disconnect from the aircraft and cause unnecessary losses.

### **Use EVO II GNSS base station**

1. Adjust the base station to a suitable height.
2. Power on the base station and wait for the system to complete initialization.
3. Power on the remote controller and the aircraft, and make sure that Autel Voyager is running.
4. Enter the mission flight interface, click the gear icon in the upper right corner, enter the settings menu, click "remote control", and confirm that the "use base station connection" option is turned on.
5. Confirm that the base station RTK indicator is green, indicating that the base station RTK is working properly. Check that the RTK status in the upper right status bar is FIX,



which means the aircraft has entered RTK positioning mode.

### **Firmware upgrade** (Is there a firmware upgrade?) How to upgrade

base station firmware

1. Make sure that the entire UAV system (including aircraft, base station, and ground station) is turned on and connected normally.
2. Run the Autel Voyager App, enter the "Settings" interface, click "Software Update -> UAV Firmware", and complete the upgrade operation of the entire system according to the system prompts. In order to ensure the reliability of the UAV system, it is not recommended to upgrade only a certain module separately. The firmware package should be used for the overall upgrade. The system will automatically recognize whether each module version matches and decide whether to upgrade it.

## **Appendix**

### Specifications Parameters

GNSS receiver	satellite receiving frequency point	simultaneous reception: GPS: L1, L2, L5 BeiDou: B1, B2, B3 GLONASS: F1, F2 Galileo: E1, E5A, E5B
	positioning accuracy	single point level: 1.5 m (RMS) Vertical: 3.0 m (RMS) RTK horizontal: 1 cm + 1 ppm (RMS) Vertical: 1.5 cm + 1 ppm (RMS) 1 ppm: each increase of X km, the accuracy becomes worse by X mm. For example distance from the base station is X , if the km, the accuracy is X cm.
	Positioning update rate	1 Hz, 2 Hz, 5 Hz, 10 Hz and 20 Hz
	cold start	<40 s
	hot start	<5 s
	recapture	<1 s
	initialization reliability	> 99.9%
	differential data transmission format	RTCM 2.X/3.X

Communication and data storage	data link	Wi-Fi
	operating frequency	2.4/5.8GHz;
	equivalent isotropic radiated power (EIRP)	Wi-Fi 2.4 GHz SRRC/CE/MIC/KCC: <20 dBm; FCC/NCC: <22 dBm 5.8 GHz SRRC/NCC/FCC: <22 dBm CE: <14 dBm
	Memory capacity	No
inertial measurement unit	Functional characteristics	Built-in 6-axis IMU
electrical characteristics	Power consumption	7.5 W
	Power supply	5 to 20 VDC
	Battery	type: Lithium polymer battery Capacity: 4950 mAh Energy: 57.1 WH
	Working time	> 7.5 h
Physical characteristics and	dimensions (base station body + extension pole)	193 mm×177 mm×73 mm Weight 1275g
	Dust-proof and waterproof	IP56
Working environment temperature	-20°C to 50°C	

## **FCC Statement**

This equipment has been tested and found to comply with the limits for a Class B digital device, pursuant to Part 15 of the FCC Rules. These limits are designed to provide reasonable protection against harmful interference in a residential installation. This equipment generates uses and can radiate radio frequency energy and, if not installed and used in accordance with the instructions, may cause harmful interference to radio communications. However, there is no guarantee that interference will not occur in a particular installation. If this equipment does cause harmful interference to radio or television reception, which can be determined by turning the equipment off and on, the user is encouraged to try to correct the interference by one or more of the following measures:

- Reorient or relocate the receiving antenna.
- Increase the separation between the equipment and receiver.
- Connect the equipment into an outlet on a circuit different from that to which the receiver is connected.
- Consult the dealer or an experienced radio/TV technician for help.

### **§ 15.19 Labeling requirements.**

This device complies with part 15 of the FCC Rules. Operation is subject to the following two conditions: (1) This device may not cause harmful interference, and (2) this device must accept any interference received, including interference that may cause undesired operation.

### **§ 15.21 Information to user.**

Any Changes or modifications not expressly approved by the party responsible for compliance could void the user's authority to operate the equipment.

The antenna(s) used for this transmitter must be installed to provide a separation distance of at least 20 cm from all persons and must not be co-located or operating in conjunction with any other antenna or transmitter.

## **IC STATEMENT**

This device complies with Industry Canada's licence-exempt RSSs. Operation is subject to the following two conditions:

- (1) This device may not cause interference; and
- (2) This device must accept any interference, including interference that may cause undesired operation of the device.

Le présent appareil est conforme aux CNR d'Industrie Canada applicables aux appareils radio exempts de licence. L'exploitation est autorisée aux deux conditions suivantes: (1) l'appareil ne doit pas produire de brouillage, et (2) l'utilisateur de l'appareil doit accepter tout brouillage radioélectrique subi, même si le brouillage est susceptible d'en compromettre le fonctionnement.

In order to avoid the possibility of exceeding the ISED radio frequency exposure limits, human proximity to the antenna shall not be less than 20cm (8 inches) during normal operation.

Afin d'éviter la possibilité de dépasser les limites d'exposition aux fréquences radio de la ISED CNR102, la proximité humaine à l'antenne ne doit pas être inférieure à 20 cm (8 pouces) pendant le fonctionnement normal.

**Note: The**

content is subject to update without notice.

You can check the latest version on the official website of Autel Intelligent

<https://www.autelrobotics.cn/>