

## **Trademark Acknowledgement**

---

EVO™, Autel Explorer™, Starpoint™ and the Autel Robotics® logo are trademarks of Autel Robotics Co., Ltd., registered in China, the United States and other countries. All other products and company names mentioned in this User Manual are registered trademarks of their respective holders.

## **Copyright Warning**

---

Without the written permission of Autel Robotics, no part of this manual can be reproduced or retransmitted in any form or by any means, including electronic, mechanical, photocopying, recording, etc.

## **Disclaimer**

---

This product is not intended for using by children without an adult's supervision. When EVO is idle, it is recommended to keep it out of reach of children.

Download the latest instructions from <https://www.autelrobotics.com/support/downloads/>.

While the contents of the instructions have been carefully checked for accuracy, no guarantee is given to the completeness and correctness of the contents, including but not limited to the product specifications, functions, and illustrations.

When using EVO, always refer to and follow the safety instructions in this manual. Do not attempt to disassemble, modify or reconstruct any part of the devices and do not use this product for illegal purposes.

Autel Robotics takes no responsibility and provides no warranty for direct or indirect product damage or injury if the customer fails to follow the safety instructions. Autel Robotics will not be liable for any direct damages or any legal, special, incidental, indirect damages or any economic loss (including but not limited to the loss of profits).

The safety instructions herein have already covered all situations currently known by Autel Robotics. Since Autel Robotics is unable to predict all possible hazards in order to give corresponding advice, you must be certain that any action performed by yourself does not jeopardize your personal safety or the safety of others, including but not limited to persons, animals, property, etc.

## **Data Storage and Usage**

---

When using a mobile app with the aircraft, data associated with the use and operation, such as flight telemetry, will be automatically (if enabled) or manually uploaded and maintained on data servers designed by Autel Robotics.

All telemetry and flight logs are stored on data servers located within the boundaries of the continental United States and only if the user has enabled the “Flight Log Backup” service. When the backup service is disabled (default) there will be no flight or user data uploaded or transmitted off the mobile device.

Autel personnel do not have access to flight log data except when explicitly granted permission by the user, using the mobile app. When permission is granted, only the selected flight logs are granted for access, other logs outside the selected date range remain inaccessible. This type of access is commonly used for customer service inquiries but is not limited solely for this purpose.

Information, including still and motion imagery in addition to information from the aircraft’s sensors, will be stored on the internal storage device located within the aircraft. In cases when the aircraft is sent to Autel Robotics for service, the information in the internal storage unit may be used in order to diagnose aircraft faults. The information will not be retained except as required to process the service or repair. Removal or intentional alteration to the data located on the internal storage device will invalidate all warranties and claims thereof.

The purpose of gathering this data is to provide support and service for you and to improve the performance of our products. Our disclosure of uploaded data including your username as required by law is necessary to protect our rights or property.

## Safety Instructions

---

### Battery Safety Instructions

The aircraft is powered by a Lithium-Polymer battery. The misuse of Li-Po/Li-Ion batteries can be extremely hazardous, special attention is required during usage.

**Carefully read and follow all the battery safety instructions to avoid personal injury or property damage.**

---

#### **WARNING**

- The Lithium-Polymer battery is factory replaceable only. Incorrect replacement or tampering with the battery pack may cause an explosion.
- Battery electrolytes are highly corrosive. If any electrolyte is splashed onto your skin or in your eyes, immediately wash the affected area with fresh running water and see a doctor.

---

#### Usage

- Only use the battery and charger provided by Autel Robotics. An unapproved battery or charger may result in fire, explosion, leakage or other hazards. Autel Robotics takes no responsibility for any damage caused by non-Autel-

Robotics batteries or charging devices.

- Always turn off the aircraft before installing or removing the battery.
- Remove the battery from the aircraft after use to prevent trickle discharge.
- Keep the battery away from water or any kind of liquid. Using or charging a wet battery may lead to an explosion.
- Do not expose the battery to fire, explosions, or other hazards.
- Do not disassemble, open, crush, bend, deform, puncture, or shred the battery.
- Do not modify, remanufacture, or attempt to insert foreign objects into the battery.
- Do not place heavy objects on the battery or charger.
- Stop using or charging the battery immediately whenever the battery starts to swell, smoke or leak.
- Use the battery at temperatures between -10°C and 40°C. Extremely high temperatures may cause a fire or explosion, extremely low temperatures may lead to permanent battery damage.
- Before using a low-temperature battery (between -10°C and 15°C) for flight, you need to fully charge it in required temperatures, or insert it into an aircraft and make the aircraft hover at the altitude of 1m to warm the battery up to 15°C or higher. The battery temperature can be checked using the mobile the app.
- Do not use the battery in strong electrostatic or electromagnetic environments, otherwise serious accidents will occur during flight.
- The heavier the aircraft loads, the shorter the flight time
- Remove the battery from the aircraft immediately if the aircraft falls into water during flight. Leave the battery in an open area and keep a safe distance away until it is completely dry. Stop using this battery and contact Autel Robotics customer support.

## **Charging**

- Do not use a damaged battery charger.
- When the charger is not in use, disconnect it and examine its condition regularly.
- Do not leave the battery alone during the charging process.
- Do not charge the battery immediately after using, as overheat protection will be activated to prevent the battery from being charged before it cools completely.
- The charging time varies depending on the remaining battery level.

- Since over charging may shorten the battery life, stop charging the battery once it is fully charged.
- Go through a charge cycle (charge the battery to 100% and then discharge it to 7% or lower) every three months, or once the battery is cycle-charged 20 times.
- It should take a maximum of 150 minutes to fully charge the battery.

### **Storage**

- Keep the battery out of reach of children and pets.
- Do not leave the battery close to moisture or heat sources. Store the battery in a dry and ventilated area at room temperature (ideally 22°C to 28°C).
- Do not place the battery beside hard or sharp items, or on a conductive surface (e.g., metal plate).
- Do not place the battery in wet grass or in the pocket with metal objects.
- Make sure the battery voltage level does not fall below 3V during storage.
- Using or storing the battery in extreme environments may reduce the battery life.
- Battery life inevitably shortens over time. And battery life may be reduced if it is left unused over extended periods of time.

### **Disposal**

- Completely discharge the battery before disposal.
- Dispose of the battery properly at approved battery recycling locations.

## **Aircraft Safety Instructions**

### **Take-off and Landing**

- Place the aircraft in a distance of approximately 5 meters heading away from you and on a level surface. Flying with an experienced pilot for the first flight is strongly recommended.
- Do not take off or land on slopes or uneven surfaces.
- Fly in an open and safe area. Avoid buildings, trees, people, and moving vehicles, power lines, etc.
- Once below one meter when landing, make sure to keep the aircraft steady.
- Land immediately when the low battery warning sign is displayed, even if the flight is almost finished. Temperature and wind conditions may affect the use of energy from the battery.

### **Flight Requirements**

- Avoid flying the aircraft at a low altitude or getting too close to people.
- Keep the aircraft in sight all the time.
- Keep the aircraft away from potential obstacles such as trees, buildings, power lines, etc.
- Leave enough space for turning and moving.
- Do not fly in severe weather conditions, including but not limited to typhoons, tornadoes, rain, storms, thunderstorms, hail, or snow.
- Avoid flying near hazardous situations, including but not limited to fire, explosions, landslides, floods, or earthquakes.
- Keep away from facilities that could produce electromagnetic interference to avoid failure of positioning, including but not limited to power plants, power transmission lines, transformer substations, or broadcasting towers.
- Avoid interferences from other remote controllers and interference sources.
- Follow the corresponding instructions once a warning appears on the app.
- Make sure you are not drunk, taking drugs or suffering from dizziness, fatigue or any other conditions, which will impair your ability to operate the aircraft safely.
- Always turn on the remote controller first then the aircraft (except during the pairing operation), and power off the aircraft first then the remote controller.

---

 **WARNING**

If any part of the aircraft (including motor, battery, gimbal, compass, propellers, LED lights, pairing buttons, etc.) or the remote controller fails to function properly or has visible/invisible damages, DO NOT FLY THE AIRCRAFT.

---

### Storage and Maintenance

Keep the aircraft, including camera gimbal holder and propellers, out of the reach of children and pets. Store the aircraft in a cool and dry place and keep away from water, heat sources, humid and hostile environments. The recommended storage temperature for the aircraft is 22°C to 28°C.

---

 **NOTE**

- The storage method for the aircraft is also suitable for the aircraft battery and remote controller.
  - Carefully check every part of the aircraft after any crash, contact customer service center of Autel Robotics if issues are noticed or if you have questions.
-

# Contents

<b>Chapter 1 About This Manual</b>	<b>1</b>
1.1 Legend	1
1.2 Before Your First Flight	1
1.2.1 Read Instructions	1
1.2.2 Install the Mobile App (Optional)	2
<b>Chapter 2 Get to Know the Smart Drone</b>	<b>3</b>
2.1 Aircraft	3
2.1.1 Functionality Description	3
2.1.2 Flight LED Indicators	5
2.1.3 Aircraft Battery	6
2.1.4 Gimbal and Camera	9
2.1.5 Built-in Smart Flight System	11
2.1.6 Smart Flight Features	12
2.2 Remote Controller	16
2.2.1 Functionality Description	16
2.2.2 Flight Information Panel	18
2.2.3 Indicator Lights	19
2.2.4 Remote Controller Buzzer Alerts	20
<b>Chapter 3 Prepare the Flight</b>	<b>21</b>
3.1 Prepare the Battery	21
3.1.1 Install the Aircraft Battery	21
3.1.2 Remove the Aircraft Battery	21
3.1.3 Charging	21
3.2 Prepare the Remote Controller	23
3.2.1 Unfold the Remote Controller	23
3.2.2 Power Up/Off the Remote Controller	24
3.2.3 Calibrate the Remote Controller	24
3.2.4 Pair the Aircraft and Remote Controller	25

<b>3.3 Prepare the Aircraft</b>	<b>26</b>
3.3.1 Unfold the Aircraft	26
3.3.2 Install the Propellers	27
3.3.3 Calibrate the Compass	28
<b>Chapter 4 Flight Operations</b>	<b>31</b>
4.1 Preflight Checklist	31
4.2 Remote Controller and Flight Operations	31
4.2.1 Motor Start and Takeoff	32
4.2.2 Command Stick Controls (Mode 2)	33
4.2.3 Landing and Motor Shut-down	34
<b>Chapter 5 Maintenance and Service</b>	<b>37</b>
5.1 Firmware Upgrade	37
5.2 Troubleshooting Tips	38
5.3 Storage and Maintenance Instructions	39
5.4 Warranty	39
5.5 Customer Service	40
5.5.1 Technical Support	40
5.5.2 Repair Service	40
<b>Chapter 6 Appendix</b>	<b>42</b>
6.1 Regulatory Compliance and Flight Restricted Area	42
6.1.1 Compliance and Advisory	42
6.1.2 Flight Restricted Area Illustration	43
6.2 Specifications	45





## Chapter 1

# About This Manual

Thank you for purchasing EVO and welcome to the Autel Robotics family. This manual describes details of the functions and operations related to the aircraft and remote controller. Read this manual carefully before you use the smart drone. If the aircraft fails to work properly, refer to the [Troubleshooting Tips](#) (  38) located at the end of this document. All legends, images, specifications and descriptions mentioned in this manual are for demonstration only.

## 1.1 Legend

---

-  **WARNING:** Precautions of a potentially hazardous situation which may lead to personal injury or property damage.
-  **IMPORTANT:** The information that demands special attention during the flight operation.
-  **NOTE:** Additional information that complements the current topic.
-  **TIPS:** Suggestions that help you make better use of this smart drone.
-  **REFERENCE:** A page number that guides you to the section containing relevant information in this manual.

## 1.2 Before Your First Flight

---

### 1.2.1 Read Instructions

Read the following documents before using the EVO:

*EVO Packing List*

*EVO Disclaimer and Safety Instructions*

*EVO Quick Guide*

*EVO User Manual*

*EVO App Manual*

Verify all the items in the box according to the *Packing List*, and contact Autel Robotics or local retailers if items are missing.



Carefully read *Disclaimer and Safety Instructions* before use to prevent damage and be in accordance with all applicable laws, rules and regulations.

Refer to the *Quick Guide* for the basic operation. Learn *User Manual* and *App Manual* from <http://www.autelrobotics.com> if you have any further questions.



**WARNING**

- Make sure there is no foreign objects (such as water, sand, oil, etc.) in the box, the aircraft and other components are clean and in perfect condition.
  - Use only authorized accessories approved or provided by Autel Robotics, do not use incompatible components or alter the product by any means inconsistent with the instructions provided by Autel Robotics.
- 

## 1.2.2 Install the Mobile App (Optional)

If you wish to use the mobile app, search for 'Autel Explorer' from the App Store or Google Play and install the app for EVO on your mobile device. The app enables a live stream and full functions of flight and camera control on your mobile device.



## Chapter 2

# Get to Know the Smart Drone

EVO is the latest evolution in drone design and technology. Obstacle avoidance, Intelligent Flight Modes, and a completely redesigned mobile app create an exciting and safe experience like nothing else. Exploring the world requires safety, reliability, and performance. EVO's ergonomic controller, Smart Flight System and stabilized 3-Axis Camera Gimbal allows you to experience and capture your world in powerful new ways.

## 2.1 Aircraft

The EVO aircraft is a foldable quadcopter with stabilized 3-Axis Camera Gimbal and integrated HD camera.

### 2.1.1 Functionality Description

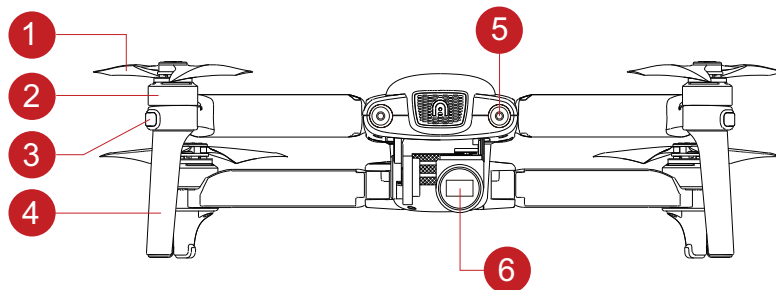

Front Side

- |                        |                         |
|------------------------|-------------------------|
| ① Propellers           | ④ Landing Gear          |
| ② Motors               | ⑤ Forward Vision System |
| ③ Front LED Indicators | ⑥ Camera Gimbal         |

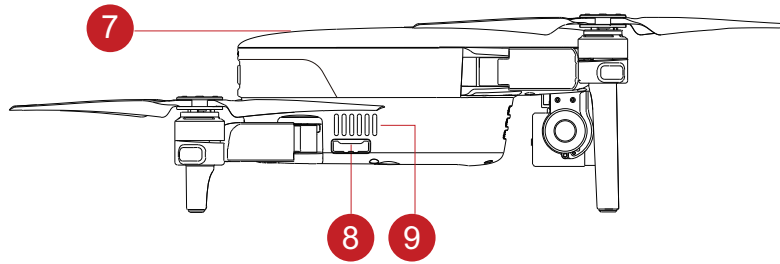

Right Side

- ⑦ Aircraft Battery ( ⑥ )
- ⑧ Micro-SD Card Slot
- ⑨ Fan Exhaust

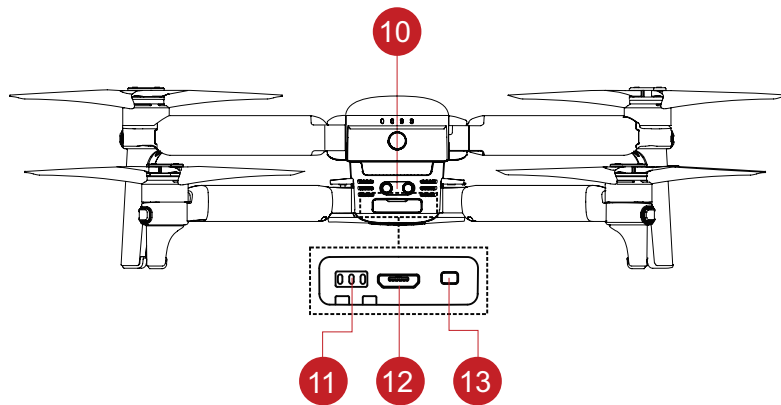

Rear Side

- ⑩ Rear Avoidance Sensor
- ⑪ Pairing Switch
- ⑫ Micro-USB Port
- ⑬ RC Pairing Button/LED Indicator

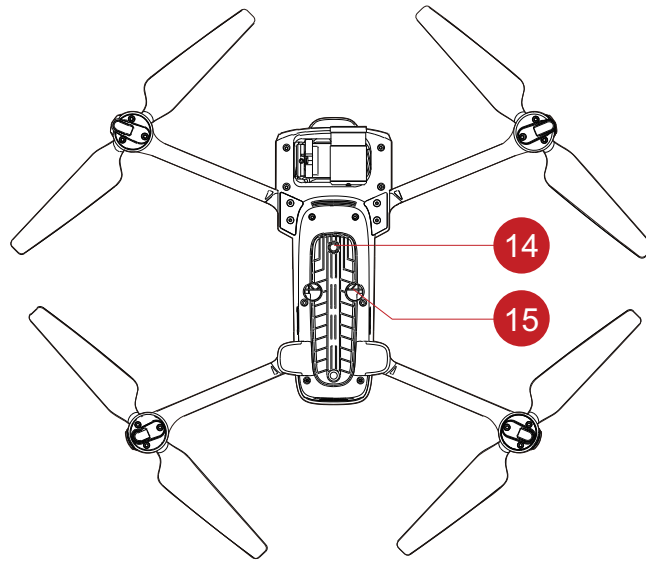

Bottom Side

- ⑭ Downward Vision System      ⑮ Ultrasonic Sensor

## 2.1.2 Flight LED Indicators

There are four LEDs located on the end of the aircraft arms, one on each arm. The color and flashing rate of the LEDs indicate the aircraft's status, working mode and battery level. The front indicators will be solid red to help you identify the direction of the aircraft's nose, and the rear indicators show the current flight status of the aircraft.

The LEDs will light up when the aircraft is turned on. The table below describes the meaning of the rear LED Indicators.

- |    |  |   |              |
|----|--|---|--------------|
| ●  | Solid Light  | R | Red Color    |
| ⊙  | Slow flashing: Flashes once per second                     | G | Green Color  |
| ⊙⊙ | Fast flashing: Flashes 3 times per second                  | Y | Yellow Color |
| ○  | Interval flashing: Flashes once every two seconds          |   |              |
| ⊙⊙ | Double flashing: Flashes two times then pauses and repeats |   |              |
| ●⊙ | Alternate flashing: Alternate among different colors       |   |              |

Example: "R-●" Solid Red light

<b><i>Definitions of Flight LED Indicator Light Status</i></b>	
<b><i>Normal Status</i></b>	
<b>R&amp;G&amp;Y-●◎</b>	System Self-test is activated
<b>Y&amp;G-●◎</b>	The aircraft is warming up
<b>G-◎</b>	The aircraft is in GPS mode
<b>G-◎◎</b>	The Forward Vision System and Starpoint™ Positioning System are enabled
<b>Y-◎</b>	The aircraft is in ATTI mode
<b>G-◎◎</b>	The aircraft is braking
<b><i>Warning</i></b>	
<b>Y-◎◎</b>	There is no connection between the aircraft and the remote controller
<b>R-◎</b>	Low Battery Warning (meaning the battery level is less than 25%)
<b>R-◎◎</b>	Extremely Low Battery Warning (meaning the battery level is less than 15%)
<b>R-○</b>	IMU error or calibration failed
<b>R-●</b>	Critical problems or abnormalities
<b>R&amp;Y-●◎</b>	Abnormal compass, calibration is required
<b><i>Compass Calibration</i></b>	
<b>Y-●</b>	Be ready to calibrate the compass
<b>G-●</b>	Horizontal calibration is successful
<b>G-◎</b>	Vertical calibration is successful

### **2.1.3 Aircraft Battery**

The Li-Po battery is rechargeable with the capacity of 4300mAh specially designed for the EVO. It can only be charged with the charger supplied in the EVO package. A fully charged battery can provide up to 30 minutes of continuous flight.

● **Basic Functions**

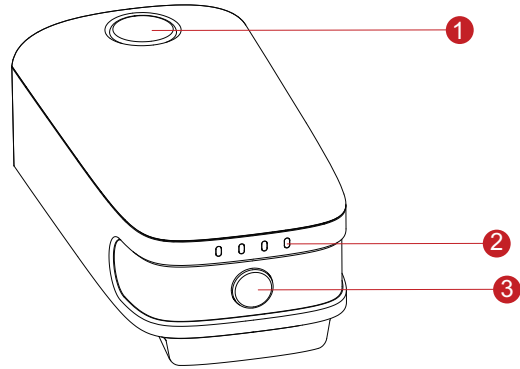

**Aircraft Battery**

- ① Removing Button
- ② Capacity Level Indicators
- ③ Power Button

➤ **Turn on the battery**

Press and hold the **Power Button** for 3 seconds to turn on the battery. The **Capacity Level Indicators** will illuminate and indicate the current battery level.

➤ **Turn off the battery**

Press and hold the **Power Button** for 3 seconds to turn off the battery. If the battery is attached on the aircraft, the LED1 and LED 4 will flash for 5 times to indicate shutdown. Remove the aircraft battery from the aircraft after turning off all the **Capacity Level Indicators**.

➤ **Check the battery level**

The battery level also can be checked without powering on the battery, press the **Power Button** for 1 second then release it quickly, then the corresponding battery levels will be indicated by the **Capacity Level Indicators** as showing below.

<i>Battery Level Indicator Status While Discharging</i>				
87.5%~100%	75%~87.5%	62.5%~75%	50%~62.5%	37.5%~50%
25%~37.5%	12.5%~25%	0%~12.5%		
- Solid Green Light              - Flashing Green Light              - No Lights				

## ● Smart Functions

Several smart functions added into the aircraft battery will protect and preserve battery life. The introduction below will give you a further understanding for the aircraft battery.

- **Storage Self-Discharge Protection:** The battery will discharge automatically to approximately 70% of total power to prevent damage. Automatic discharge begins after the battery has been idle for 6 days (default) and the battery voltage is higher than 12V. It takes 2 or 3 days for the battery to discharge. There is no indication when the self-discharge cycle is being performed. You may notice a slight warming of the battery during the discharge process, this is normal. The discharge threshold can be modified using the Autel Explorer app.
- **Charging Temperature Detection:** The normal charging temperature should be between 10°C (50°F) and 45°C (113°F), the battery will stop charging if the temperature exceeds this range.
- **Over Current Protection:** The battery will stop charging if the charging current exceeds 8A in order to prevent severe damage.
- **Overcharge Protection:** Charging will stop automatically when the battery reaches full charge.
- **Balance Protection:** Balances the voltage of each battery cell to prevent overcharging or over-discharging.
- **Over Discharge Protection:** If the battery is not in use, it will disconnect power output once the self-discharge cycle has completed. The over discharge protection is inactive during the flight.
- **Short Circuit Protection:** The power supply will be cut off if a short circuit is detected.
- **Power Saving Mode:** The battery will cut off the power supply and enter power saving mode after 30 minutes of inactivity to retain the energy.
- **Communication:** The aircraft is able to communicate with the battery to get real time battery information such as voltage, capacity, current, temperature, etc.
- **Ultra-Low Power Consumption Mode:** To save power, the battery will enter the Ultra-Low Power Consumption Mode if it is idle for 7 days and the battery

voltage is lower than 11.7V. In this situation, the battery can be used normally after being connected to the charger.

## 2.1.4 Gimbal and Camera

### ● XI-5A Camera Gimbal

The **XI-5A Camera Gimbal** enabled the camera to capture clear photos and videos. It is specially designed to minimize camera vibration and provides the best experience for you. The controllable range of the gimbal roll axis is 0°~90° and the operating temperature is maintained between -10°C~50°C (14°F~122°F).

The gimbal is powered by the aircraft battery, and a self-test is performed each time the gimbal starts where the gimbal will rotate through its limits and calibrate itself. The picture below helps you familiar with every part of the gimbal and camera.

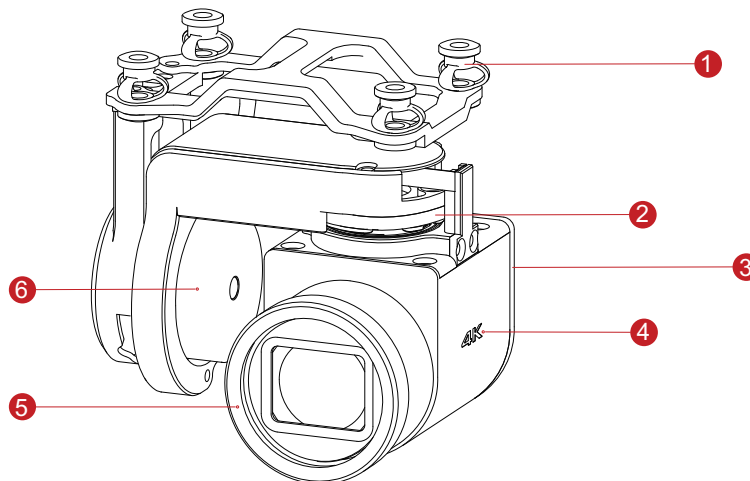

- |                      |               |
|----------------------|---------------|
| ① Vibration Absorber | ④ Camera      |
| ② Yaw Motor          | ⑤ Filter      |
| ③ Roll Motor         | ⑥ Pitch Motor |



---

 **NOTE**

- When stored the **XI-5A Camera Gimbal** is held in place with a gimbal holder to protect the gimbal from incidental rotation and avoid damage.
  - **Remember to remove the holder before powering up the aircraft. Failure to remove the gimbal holder may result in damage and overheating of the gimbal motors and circuitry.**
- 

The **XI-5A Camera Gimbal** for **EVO** supports two working modes:

**Stabilized Mode:** The gimbal's orientation will always remain constant with the aircraft's nose, but the gimbal will keep horizontal even when the aircraft tilts.

**FPV Mode:** The gimbal will be synchronized with the aircraft's movement including rotation and tilt to create a first-person view during the flight.

### ● Camera

If you wish to capture photos and videos, insert a micro SD card into the Micro-SD Card Slot shown in the picture before turning on the aircraft. EVO supports SD card capacity up to 128GB, which creates the possibility of saving more pictures and videos during the flight. It is recommended that you use a Class 10 or UHS-1 micro SD card to catch high-definition videos.

### ➤ Micro SD Card

If you wish to capture photos and videos, insert a Micro SD card into the **Micro-SD Card Slot** shown in the picture before turning on the aircraft. EVO supports SD card capacity up to 128GB, which creates the possibility of saving more pictures and videos during the flight. It is recommended that you use a Class 10 or UHS-1 Micro SD card to catch high-definition videos.

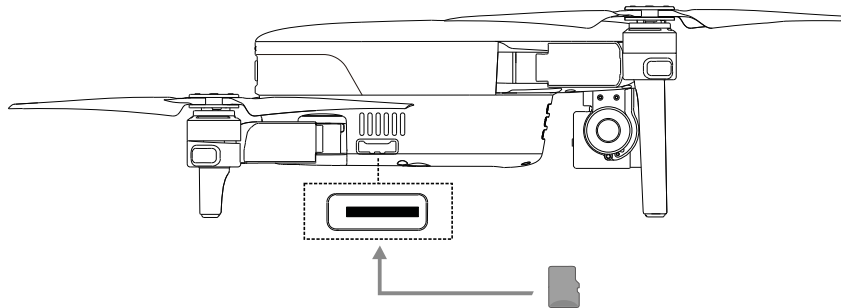

---

**! IMPORTANT**

Do not pull out the Micro SD card from the aircraft when powered on, otherwise the video and photo files may be lost.

---

➤ **File Transmission**

The **Micro-USB Port** on the back of the aircraft is used to transfer your photos and videos to the computer.

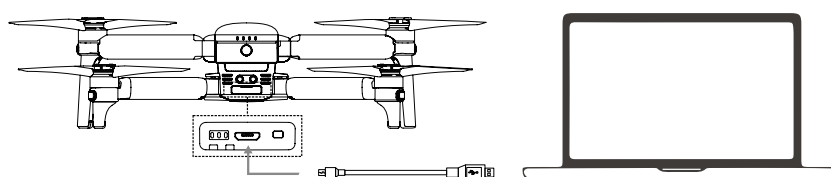

## 2.1.5 Built-in Smart Flight System

EVO features a built-in smart flight system which provides stable and user-friendly flight control. The system consists of various sensors such as the Binocular Vision System, Rear Avoidance Sensor, Global Navigation Satellite System (GNSS) receiver, Compass, Inertial Measurement Unit (IMU) and barometer. This system works as the central computer of the aircraft and supports various functions, such as Go Home, Failsafe, Starpoint™ Positioning System, etc.

<i>Smart Flight System Modules</i>	
Module	Description
IMU	An electronic device consisting of a 3-axis gyroscope and a 3-axis accelerometer that measures the acceleration and angular rates of the aircraft. An automatic IMU calibration is performed each time you power on the aircraft.
Compass	Measures geomagnetic field and provides heading reference for the aircraft.
GNSS Receiver	Receives GNSS (GPS/GLONASS) signals to determine the latitude, longitude and altitude of the aircraft.
Barometer	Measures atmospheric pressure to determine the altitude of the aircraft.

Ultrasonic Sensors	Measures the distance between the aircraft and the ground.
Binocular Vision System	Forward and Downward Vision System.
Rear Avoidance Sensor	An Infrared Transmitter and Receiver are equipped to the rear of the aircraft to scan and avoid the obstacles.

## ● Flight Modes

Two flight modes allow the aircraft fly in different environments.

<i>Flight Modes</i>	
Flight Modes	Description
GPS Mode	GPS Mode is activated if the aircraft detects good GNSS signals. GPS, together with Forward and Downward Vision Systems, locate, stabilize and navigate the aircraft among obstacles, providing stable and smooth flight maneuvers, as well as safety features including Go Home and Failsafe.
ATTI Mode	ATTI Mode is automatically activated when the GPS signal is weak and lighting conditions are insufficient for the Vision Systems to work. Obstacle Avoidance features are disabled and the aircraft uses only its barometer for controlling altitude.

## 2.1.6 Smart Flight Features

### ● Go Home

The **Go Home** function can be enabled when good GPS signal is available. To manually activate the **Go Home** process, press and hold the **Go Home Button** (  ) for 3 seconds on the remote controller to send the **Go Home** command to the aircraft. Once the aircraft receives this command, it will return automatically and land at the present home point.

According to the new design, the aircraft is able to detect and avoid obstacles on its flight path using **Forward Vision System**. Normally the remote controller's function will be disabled temporarily while the aircraft returns to the home point, but you can still regain control of the aircraft by pressing the **Pause Button** (  ) on the remote controller if the **Forward Vision System** is disabled during this period.

---

**! IMPORTANT**

- When the **Go Home** function is activated, for safety reasons, if the aircraft is hovering at the altitude lower than 30 meters, it will ascend to an altitude of 30 meters above the home point before starting to return. You can adjust the **Go Home** altitude in the app.
  - If the **Go Home** function is activated within 10 meters radius from the home point, the aircraft will land automatically in-place from its current altitude.
- 

● **Failsafe**

The **Failsafe** function is designed to help EVO automatically return home or land onsite when necessary.



➤ **Communication Lost**

**Failsafe** will be triggered 3s after the communication between your aircraft and remote controller gets lost.

If GPS is available when activating the **Failsafe** function, the aircraft will start the **Go Home** procedure automatically, otherwise it will land onsite. When the remote controller signal comes back, you can still press the **Pause Button** (  ) to regain control of the aircraft.

➤ **Low Aircraft Battery Level**

**Failsafe** will also be activated if you meet one of the following low battery conditions.

- A. Your aircraft battery constantly calculates the required battery level for the aircraft to return to the home point from its current location. When the battery level reaches the minimum level required for the aircraft to return to the home point, a notice displayed on the Autel Explorer app will prompt you, and **Failsafe** will be activated after 10 seconds if no action is taken. Your aircraft will automatically return home to protect itself. You can regain control of the aircraft by pressing the **Pause Button** (  ) during the **Go Home** process.
- B. Anytime your aircraft's remaining battery level reaches 25% (**Low Battery Warning**), **Failsafe** will be activated and your aircraft will automatically return home. If you regain control during this process, the aircraft will automatically land onsite when the remaining battery reaches 15% (**Extremely Low Battery Warning**). In this case, you may press the **Pause Button** (  ) to stop the aircraft landing and command it to fly away from the current location for a safe landing in case of an emergency.

---

 **NOTE**

- If the aircraft is only within 50m away (horizontal distance) from the home point when your aircraft battery level reaches 25% (**Low Battery Warning**), the aircraft will not perform the **Go Home** procedure.
  - If GPS is unavailable when **Failsafe** is activated at **Low Battery Warning**, **Go Home** procedure will not be executed. In this case, the aircraft will land automatically when the remaining battery level reaches 15% (**Extremely Low Battery Warning**).
- 

## ● Landing Features

### ➤ Landing Protection

When the aircraft arrives at the above of the home point, **Landing Protection** functionality will detect ground conditions during the landing descent. The aircraft will land automatically if the ground is level and flat, otherwise it will hover in-place to wait the next command.

### ➤ Accurate Landing

EVO will scan and match the terrain features if **Accurate Landing** function is active, it will land as close as possible to the take-off point once the current terrain matches take-off point terrain.

---

 **IMPORTANT**

- The aircraft records the take-off point as the default home point, **Accurate Landing** is only working when the home point is not refreshed during the flight.
  - Make sure there are no changes of your take-off point when the aircraft is ready to land.
  - Choose a distinctive terrain as your take-off point.
  - Choose a spot on the ground that is well lit to take off and land your aircraft.
- 

 **NOTE**

**Landing Protection** and **Accurate Landing** can be enabled via Autel Explorer app, the instructions are available in the App Manual.

---

## ● Starpoint™ Positioning System

The **Starpoint™ Positioning System** installed on EVO, functions through **Binocular Cameras** and two **Ultrasonic Sensors** on the bottom of the aircraft. The sensors identify the current height of the aircraft through ultrasound, and the camera obtains location information through image analysis.

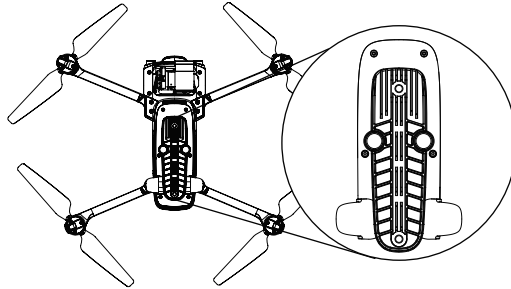

With the help of the **Starpoint™ Positioning System**, the aircraft can hover in place more precisely when flying indoors or in other environments where the GPS signal is unavailable.

---

 **NOTE**

- The **Starpoint™ Positioning System** is activated by default when the aircraft is powered on.
- The **Starpoint™ Positioning System** works both in GPS and ATTI modes and is only valid when the aircraft is between 0.5m and 10m above the surface.

---

● **Forward Vision System and Rear Avoidance Sensors**

The **Forward Vision System** installed on the front of the aircraft using image data to detect the distance between the aircraft and obstacles. The aircraft will brake by itself when obstacles are detected in front.

At the same time, infrared sensors located on the rear of the aircraft are also capable of measuring the heat being emitted by an object and detecting motion, which will help the aircraft avoid obstacles in a different way.

---

 **TIPS**

- Always keep the binocular camera lens clean for a clear view.
- Do not use other 40KHz ultrasonic devices nearby when the **Starpoint™ Positioning System** is activated.

---

**! IMPORTANT**

The performance of the **Starpoint™ Positioning System** and **Forward Vision System** are affected by the brightness and texture of the surface over which the aircraft is flying. The ultrasonic sensors may not function accurately above sound-absorbing materials. Please try to avoid the following situations:

- Flying over a monochrome surface (e.g. pure black, white, or red) or a highly reflective surface (e.g. water, transparent surfaces).
  - Flying over extremely dark or bright surfaces, or in an area where the lighting changes frequently.
  - Flying over surfaces with unclear patterns or texture, or highly repeating patterns or texture (e.g. tiles with the same design).
  - Flying over surfaces (e.g. thick carpet) that can absorb or deflect sound waves.
  - Flying at a high speed: Over 8m/s at a 2-meter height, or over 4m/s at a 1-meter height.
  - Flying over moving surfaces or objects.
- 

## 2.2 Remote Controller

---

EVO's remote controller supports live video downlink and aircraft remote control functions without the need of a mobile app. The aircraft has an unobstructed range of up to 7km if conditions are good. The video downlink system and aircraft remote control system operate at 2.4GHz or 900MHz (user selectable). The 3.3-inch OLED screen located on the remote controller displays live video feed, battery level, GPS signals, flight speed, etc.

### 2.2.1 Functionality Description

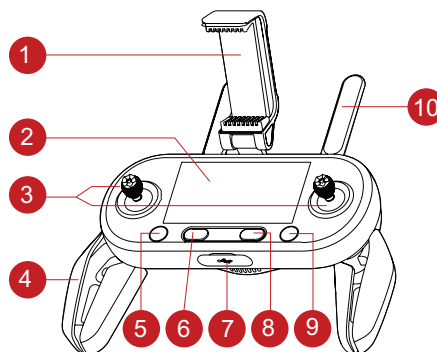

① Mobile Device Holder	Holds your mobile device with a 180° adjustable viewing angle for optimum visibility.
② Flight Information Panel	Displays the flight status, warning messages and real-time live view.
③ Command Sticks	Control the orientation and movement of the aircraft.
④ Hand Grips	Each Hand Grip is folded to realize a convenient storage. Unfold the Hand Grips to hold the remote controller in your hand.
⑤ Take-off/Landing Button	Commands the aircraft to take off or land.
⑥ Power Button	Press and hold the button for 3 seconds to turn on/off the remote controller.
⑦ USB Ports	Two USB Ports for connecting to the mobile device or charging the remote controller.
⑧ Pause Button	Commands the aircraft to pause autonomous flight operations and hover in-place. A second press and the autonomous mode will continue from the point it was paused.
⑨ Go Home Button	Commands the aircraft to return to the home point.
⑩ Antennas	Both antennas communicate with the aircraft at 2.4GHz or 900MHz for sending and receiving commands and video information.

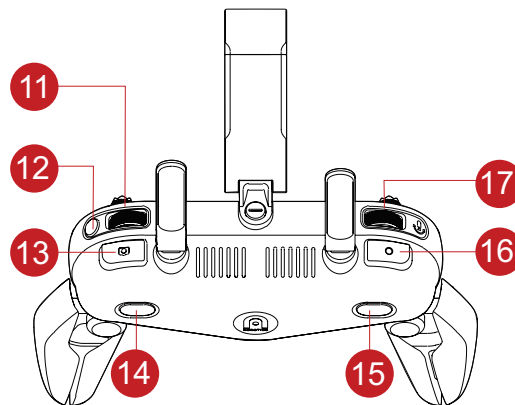

⑪ Screen Navigation Dial	Scrolls the OLED screen.
⑫ Screen Navigation Button	Navigates the menus on the OLED screen.



⑬ Shutter Button	Takes photos. When selecting the burst mode, several photos will be taken with one press.
⑭ Customizable Button #1	The function is customized by the user using the mobile app.
⑮ Customizable Button #2	The function is customized by the user using the mobile app.
⑯ Record Button	Press the button to start or stop video recording.
⑰ Gimbal Pitch Dial	The dial controls the pitch angle of the camera gimbal.

## 2.2.2 Flight Information Panel

When the video link has been connected properly, the main interface will appear as follows:



① Flight Altitude	Indicates the altitude of the aircraft relative to the home point.
② Flight Distance	Indicates the horizontal distance between the aircraft and home point.
③ Flight Speed	Indicates the current speed of the aircraft.
④ Tilt Angle	Indicates the camera's angle tilted by the gimbal. (Range: 0°~90°)
⑤ Flight Status Bar	Displays the real-time flight status and the flight mode.
⑥ Vision System	Indicates that Vision Obstacle Avoidance System is enabled.

⑦ Remote Controller Battery	<ul style="list-style-type: none"> <li>Indicates the battery level of the remote controller.</li> <li>Green bars indicate the normal battery level, orange bars indicate the low battery level (approximately 10%) and red bars indicate the extremely low battery level (approximately 5%).</li> </ul>
⑧ Remote Controller Signal	Indicates the signal strength of the remote controller.
⑨ Remaining Flight Time	Indicates the estimated Flight Time remaining for the aircraft.
⑩ Micro SD Card	Indicates the Micro SD Card is present and ready to store photos and videos.
⑪ GPS Signal	Indicates the signal strength of GNSS satellites.
⑫ Aircraft Battery	<ul style="list-style-type: none"> <li>Indicates the battery level of the aircraft.</li> <li>Green bars indicate the normal battery level, orange bars indicate the low battery level and red bars indicate the extremely low battery level (the battery level threshold can be set on the Autel Explorer app).</li> </ul>
⑬ Record Status	Indicates the aircraft is recording the videos.

## 2.2.3 Indicator Lights

A single indicator on the remote controller can be found on the **Power Button** (  ). The following table describes the definitions of the indicator light status.

●	Solid Light	R	Red Colored Light
◎	Flashing Light	G	Green Colored Light
○	No Lights	Y	Yellow Colored Light

Example: “R-●” SOLID RED light

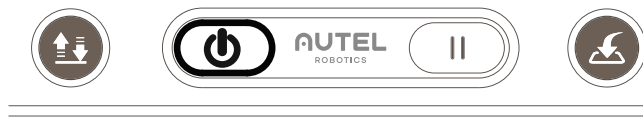

G-●	<ul style="list-style-type: none"> <li>When RC is in use, indicates sufficient battery to fly</li> <li>When charging indicates a full charge is reached</li> </ul>
G-◎	In charging state with powering on

Y-●	Low battery warning
R-●	In charging state with powering off
R-◎	In process of RC firmware upgrade
○	<ul style="list-style-type: none"> <li>Fully charged in charging state with powering off</li> <li>Power off while not in charging state</li> </ul>

## 2.2.4 Remote Controller Buzzer Alerts

A built-in buzzer in the remote controller emits different alert sounds according to various conditions, such as low battery warning, video link error or losing aircraft communication. The table below describes different meanings of alerts.

<i>Remote Controller Buzzer Alerts</i>	
Aircraft Low Battery Warning (about 25%)	1 quick beep every second (lasts for 5s), with 2 RC vibrations
Aircraft Extremely Low Battery Warning (about 15%)	5 quick beeps every second (last for 5s), with 5 RC vibrations
RC Low Battery Warning (10%)	1 quick beep every second (lasts for 5s)
RC Extremely Low Battery Warning (5%)	5 quick beeps every second (last for 3s), with 2 RC vibrations
Aircraft & RC Communication Lost	2 quick beeps every second (last for 5s), with 1 RC vibration
Video Link Disconnected	3 quick beeps in 1 second
Compass Interference	3 beeps with 3 RC vibrations
Standby Notification	3 beeps every 15 minutes of inactivity

## Chapter 3

# Prepare the Flight

EVO is factory assembled in the package and features a user-friendly design. It is possible to open the box, pull out the aircraft and remote controller to experience immediate flight. However, reading and understanding the following instructions and warnings are essential before use, in order to operate safely.

## 3.1 Prepare the Battery

### 3.1.1 Install the Aircraft Battery

1. Power off the aircraft battery before the installation.
2. Insert the battery into the aircraft battery compartment as showing on the right. The battery will firmly click in when it is properly installed.

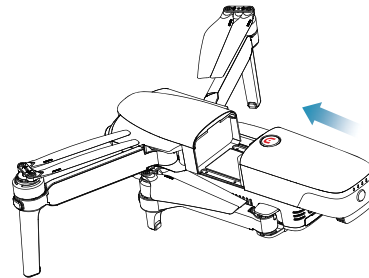

### 3.1.2 Remove the Aircraft Battery

1. Power off the aircraft battery before removal.
2. Press and hold the top button (Ⓜ) located on the battery and pull it out slowly.

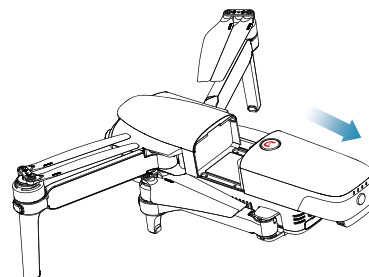

### 3.1.3 Charging

The aircraft battery and remote controller can be charged simultaneously using

the supplied charger. There are two connectors attached to the adapter block on the charger. The fixed one goes with the aircraft battery and the USB cable is used to charge the remote controller.

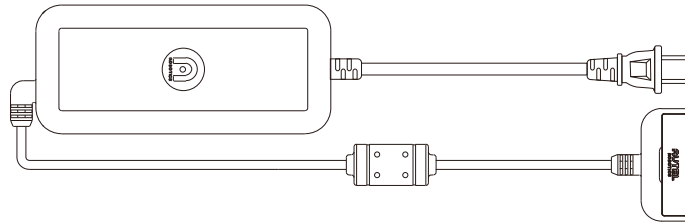

➤ **Charge the aircraft and remote controller**

1. Plug the charging connector into the charging port of the aircraft battery.



---

**! IMPORTANT**

The aircraft battery should be fully charged before use.

---

2. Flip open the protector on the USB Port located on the remote controller and plug the USB charging cable into the USB port.

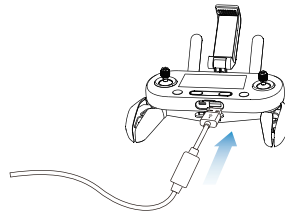

3. Plug the charger into a power outlet.

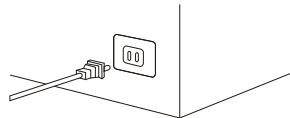

- The **Capacity Level Indicators** on the aircraft battery will illuminate from left to right indicating the current battery level during the charging cycle, and will turn off when the battery is fully charged.

<i>Capacity Level Indicator Status While Charging</i>			
75%~100%	50%~75%	25%~50%	0%~25%
● - Solid Green Light		⦿ - Flashing Green Light	

➤ The **Power Button** ( ) on the remote controller will turn green (when the RC is powered on) or solid red (when the RC is powered off) during charging. The charging process can be monitored on the **Flight Information Panel**. You will hear two beeps when the charging is completed.

4. When charging is completed, disconnect the charger and the aircraft battery/ remote controller.

**NOTE**

- Always fly with a fully charged aircraft and remote controller battery.
- It will take approximately 80 minutes to fully charge the aircraft battery and 150 minutes to fully charge the remote controller.

## 3.2 Prepare the Remote Controller

### 3.2.1 Unfold the Remote Controller

The remote controller is folded in the package. Unfold the Mobile Device Holder, Antennas, and Hand Grips carefully before the usage to prevent damage and ensure optimal range of flight.

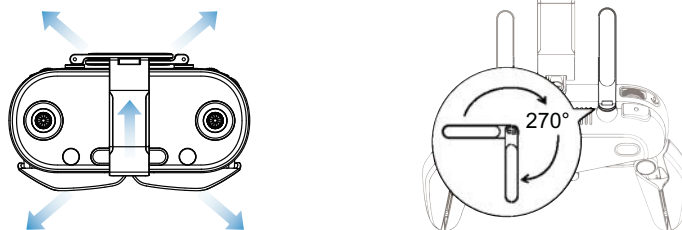

**NOTE**

The Antennas can be rotated 270 degrees as showing in the picture.

### ● Position the Antennas

To receive maximum signal strength from the controller, position the two antennas vertically to make them parallel to each other, as shown in the images below.

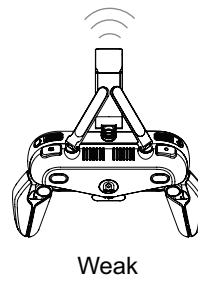
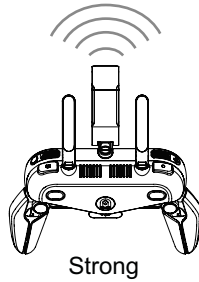

## 3.2.2 Power Up/Off the Remote Controller

### ● Power Up

Press and hold the **Power Button** (  ) for 2 seconds until you hear a short beep. Then the **Flight Information Panel** will light up and cycle through an initial verification test.

---

#### **IMPORTANT**

Always turn on the remote controller first before turning on the aircraft.

---

### ● Power Off

Press and hold the **Power Button** (  ) for 2 seconds until you hear a short beep.

---

#### **IMPORTANT**

Always turn off the aircraft before the remote controller.

---

#### **NOTE**



The remote controller makes an alert sound after 15 minutes of inactivity, and turns off automatically after 18 minutes of inactivity when not connected to the aircraft.

---

## 3.2.3 Calibrate the Remote Controller

If the **Command Sticks** are abnormal, it is recommended to calibrate the remote

controller. You can calibrate your remote controller according to the following steps, or by using the mobile app. (refer to the App Manual for more information)

1. Turn off the remote controller. Press and hold the **Power Button** (  ) and **Take-off/Landing Button** (  ) simultaneously until the screen appears as shown on the right. The four crossed bars represent the left and right **Command Sticks**, and the horizontal bar at the top represents the **Gimbal Pitch Dial**.
2. Release both **Command Sticks** and the **Gimbal Pitch Dial** naturally to the central position. The three central rounds on the RC calibration screen will be highlighted successively.
3. Push both **Command Sticks** to the ends of their 8 directions, and turn the **Gimbal Pitch Dial** clockwise and counterclockwise to its 2 ends, holding respectively until you hear a beep.
4. All the bars on the screen will be fully highlighted when calibration is completed.

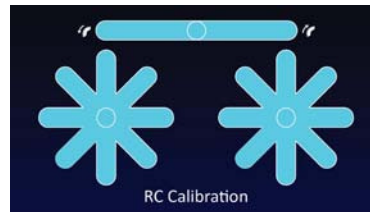
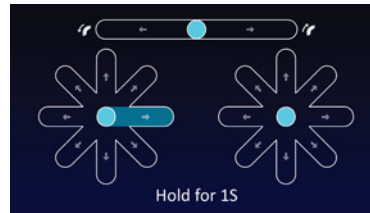
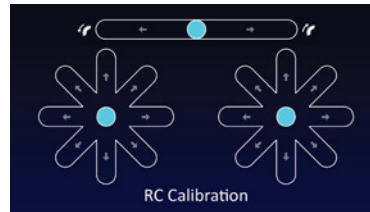
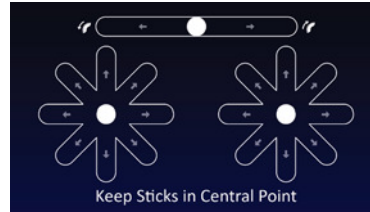

### 3.2.4 Pair the Aircraft and Remote Controller

The remote controller and aircraft are factory paired. However, when you change an aircraft or remote controller, or activate the **RC Pairing Button** on the aircraft, you will need to pair your aircraft and remote controller again.



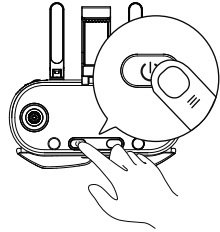

1. Turn **off** the remote controller.

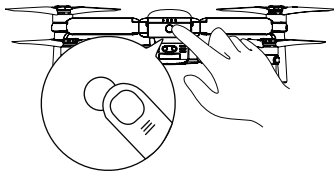

2. Turn **on** the aircraft.

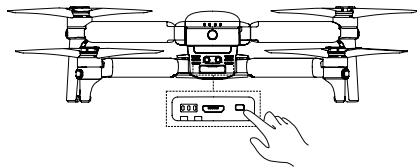

3. Press and hold the **RC Pairing Button** for about 3 seconds, the **Pairing Indicator** will flash quickly indicating the aircraft is ready to pair with the remote controller.



4. Press and hold the **Power Button** (🔌) and **Go Home Button** (🏠) simultaneously for 2 seconds until the "Autel" appears on the **Flight Information Panel**, and the Pairing Indicator will turn off once your pairing is successful.

---

 **NOTE**

You may also use the app to pair the aircraft and remote controller, the instruction is available in the App Manual.

---

## 3.3 Prepare the Aircraft

---

### 3.3.1 Unfold the Aircraft

### ● Remove and Reinstall the Gimbal Holder

Remove the gimbal holder before powering up the aircraft to avoid damage. Pull out the attached gimbal holder carefully shown in the picture.

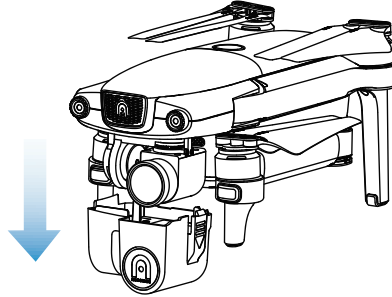

Reinstall the gimbal holder after using the aircraft to protect the gimbal from accidental damage when not in use.

### ● Unfold the Arms and Propellers

- Unfold the front arms first, then the rear ones.
- Unfold all propellers.

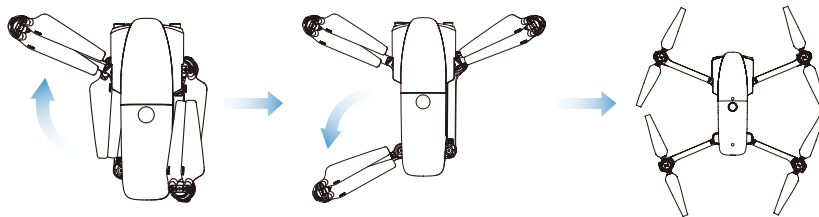

#### ! IMPORTANT

- Before powering on the aircraft, always unfold the front arms and propellers before the rear ones.
- After powering off the aircraft, always fold the rear arms and propellers before the front ones.

## 3.3.2 Install the Propellers

#### ! WARNING

You may also use the app to pair the aircraft and remote controller, the instruction is available in the App Manual.

---

**! IMPORTANT**

It is recommended that you wear protective gloves when assembling or detaching the propellers to protect you from the sharp edges.

---

**Legends**

 Lock Direction: Fasten the propeller by rotating it indicated in the picture.

 Unlock Direction: Unfasten the propeller by rotating it indicated in the picture.

 Black coded propeller > Pair with > Black Motor

 Orange coded propeller > Pair with > Orange Coded Motor

---

● **Attach the Propellers**

1. Verify the aircraft is powered off.
2. Locate and match the propeller to each motor.
3. Press each propeller down firmly and rotate in the lock direction to firmly attach the propeller.

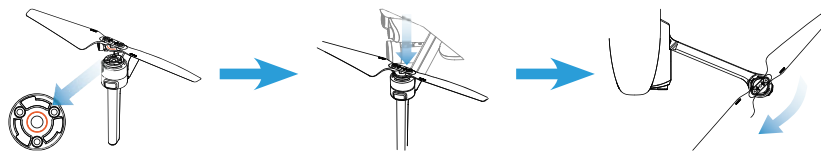

● **Detach the Propellers**

1. Power off the aircraft.
2. Press each propeller down firmly and rotate in the unlock direction to detach the propeller.

---

**! IMPORTANT**

- Check and ensure every propeller is stably attached and in good condition before each flight. Do not use old or broken propellers.
  - Do not touch the propellers or motors when they are spinning. Remove the propellers when testing the motors' operation.
  - Remove the Propellers when the aircraft is not in use.
- 

### 3.3.3 Calibrate the Compass

The compass is factory calibrated making user-calibration unnecessary. If you experience compass error warnings, or the aircraft's flight direction does not match control inputs you may need to recalibrate the compass using the following procedure.

---

 **WARNING**



The compass is very sensitive to electromagnetic interference causing compass error and poor flight. If you find the compass abnormal after calibration, move the aircraft to another location and try again.

---

Remember to meet the following requirements when carrying out compass calibration:

1. Operate calibration outdoors (ideally on an open area such as a lawn).
2. Be free from all magnetic interferences, such as magnetite or steel reinforcement found in concrete. Building and other structures may also result in a poor calibration.
3. Stay away from both underground and overhead power lines.
4. Do not carry ferromagnetic materials (e.g., keys, magnetic jewelry, etc.) with you.
5. Remove electronic devices that might interfere with the calibration (e.g., cell phones, remote controller, etc.)

### ● Calibration Procedure

1. Start the calibration process by pressing the **Take-off/Landing Button**  and **Go Home Button**  on the remote controller simultaneously for 3 seconds. When the calibration process has been initiated, the rear flight LEDs on the aircraft will turn solid yellow.

2. Hold the aircraft horizontally and rotate it until the rear flight LEDs on the aircraft turn solid green, indicating this step has been completed successfully.

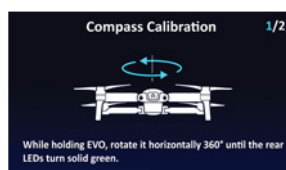

3. Hold the aircraft vertically with the nose facing downward and rotate it until the rear flight LEDs on the aircraft flash slow green, indicating that your calibration is successful.



---

 **NOTE**

- If the calibration is unsuccessful, the rear flight LEDs on the aircraft will illuminate flashing red. In this case, repeat the above steps to try again.
  - You can also calibrate the compass using the Autel Explorer app, the instruction is available in the App Manual.
-

## Chapter 4

# Flight Operations

## 4.1 Preflight Checklist

---

Follow the steps below to carry out a full preflight check-up to maximize safety.

- The aircraft battery, the remote controller and the mobile device are fully charged.
- The gimbal holder is removed.
- The **Propellers** are properly attached and in good condition.
- The antennas of the remote controller are unfolded and adjusted to a good position to obtain the best transmission quality.
- The aircraft and the remote controller are bound.
- The firmware has been updated to the latest version.
- Familiarize yourself with the flight controls.
- Your flight area is open, unobstructed and uncrowded.
- Check the weather before flying, including air temperature and wind speed.
- The sensors for **Forward** and **Downward Vision System** and camera lens are clean.

## 4.2 Remote Controller and Flight Operations

---

There are three command stick modes available for the aircraft: **Mode 1**, **Mode 2** and **Mode 3**. Each one controls the aircraft in a different manner. The control manners illustrated below base on the default command stick mode (**Mode 2**). You can change the mode according to the instruction in the app menu.

### ● Basic Flight

1. Place the aircraft in an open, level area with the battery level indicators facing to you.

2. Turn on the remote controller.
3. Turn on the aircraft and wait for the rear flight LEDs to flash slow green.
4. Start the **Motors** and take off using the remote controller.
5. Control the aircraft carefully.
6. Land the aircraft, then shut down the **Motors**.

## 4.2.1 Motor Start and Takeoff

Start the **Motors** before commanding the aircraft to take off.



### NOTE

The aircraft will not take off if the battery level is 15% or lower.

- Start the **Motors** by holding both **Command Sticks** for two seconds shown below:

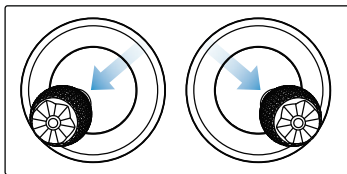

OR

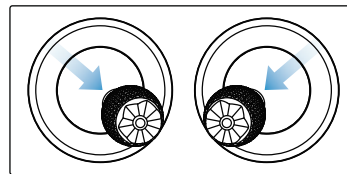

- With the **Motors** spinning, choose one of the following methods to takeoff:

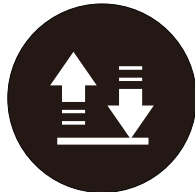

Hold the Takeoff/Landing Button for 2s

OR

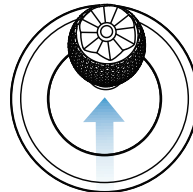

Push the Left Command Stick slowly upward (Mode 2)

If you command the aircraft to take off using the **Take-off/Landing Button** (👆), the aircraft will ascend automatically to a height of approximately 1.5 meters.



### WARNING

Make sure the **Motors** have cooled down completely before touching.

## 4.2.2 Command Stick Controls (Mode 2)

### TIPS

For beginners, it is recommended to move the **Command Sticks** using small and slow movements to keep the aircraft flying in a controllable manner and speed.

### ● Left Command Stick

#### ➤ Ascend/Descend

Command the aircraft to ascend by pushing the stick upward, and descend by pushing it downward.

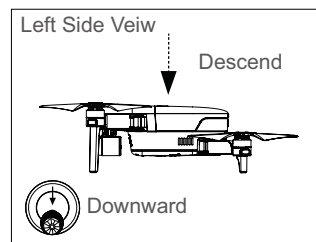
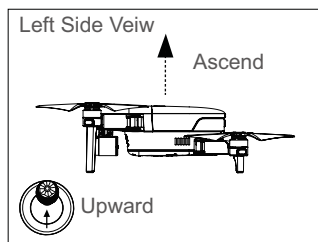

#### ➤ Rotate Left/Rotate Right

Command the heading of the aircraft to rotate left or right by pushing the stick left or right.

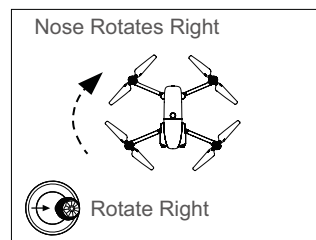
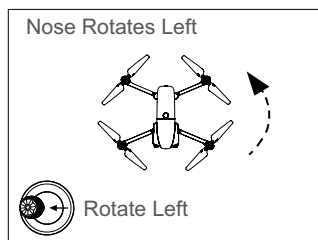

### ● Right Command Stick

#### ➤ Forward/Backward

Command the aircraft to move forward or backward by pushing the stick upward or downward.



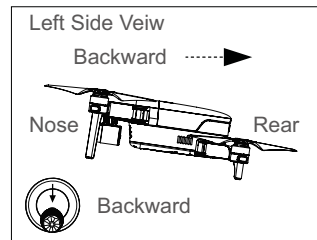
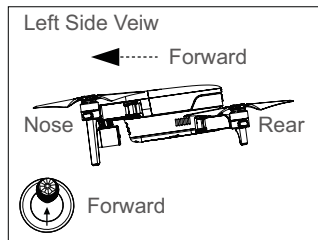

➤ **Move Left/Move Right**

Command the aircraft to move left or right by pushing the stick left or right.

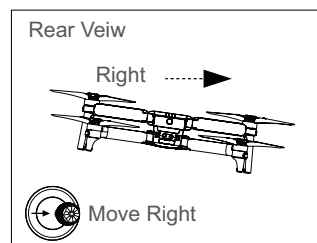
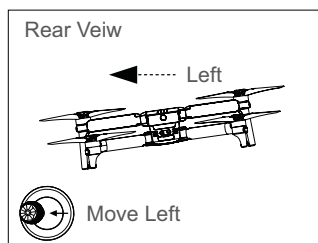

### 4.2.3 Landing and Motor Shut-down

The aircraft can be landed manually, automatically, or passively.

**! IMPORTANT**

The aircraft must be landed gently on a flat and level surface to avoid damage.

● **Manual Landing**

You can land the aircraft manually whenever and wherever you want using the **Command Sticks** on the remote controller.

➤ **Land the aircraft manually**

1. Find a desired position for landing the aircraft.
2. Release the **Command Sticks** when the aircraft reaches the target position to let it hover.
3. Push the **Left Command Stick** slowly downwards slowly to land the aircraft.

➤ **Shut down the Motors**

When the aircraft reaches the ground, choose one of the following methods to shut down the **Motors**:

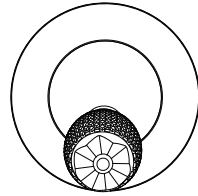

Push the Left Command Stick to the bottom and hold for 2s

OR

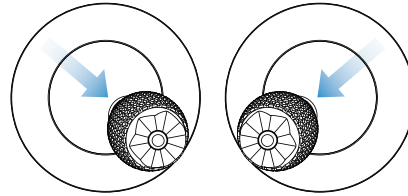

Hold both Command Sticks toe-in for 2s

---

 **WARNING**

The toe-in action will always shut down the **Motors** even if the aircraft is in midair. Pay extra cautious and use this feature only in an emergency.

---

### ● Automatic Landing

You can use the **Take-off/Landing Button** () on the remote controller to land the aircraft automatically from its current hover position.

1. Find a desired position for landing the aircraft.
2. Release the **Command Sticks** when the aircraft reaches the target position to let it hover.
3. Press and hold the **Take-off/Landing Button** () for 2 seconds until you hear a beep.
4. The aircraft will descend, land and shut off its **Motors** automatically. During landing descent, you are able to adjust the aircraft position using the **Right Command Stick**.

---

 **TIPS**

During the automatic descent process, you can regain control by pressing the **Pause Button** () on the remote controller.

---

---

 **NOTE**

- Automatic landing is also available in ATTI mode but you should control the attitude of the aircraft manually as the aircraft may drift.
- It is recommended that you land the aircraft immediately when **Low Battery Warning** (25%) is shown, i.e., the rear LEDs on the aircraft illuminate flashing red light, and the **Power Button** () on the remote controller lights up in solid yellow light.

---

● **Passive Landing**

When **Failsafe** is triggered by any of the following conditions, the aircraft will be forced to land onsite automatically.

- The **Low Battery Warning** is activated in non-GPS environment.
- The **Extremely Low Battery Warning** is activated.

## Chapter 5

# Maintenance and Service

## 5.1 Firmware Upgrade

---

To optimize the performance of your EVO, firmware update will be provided on a regular basis. You can download the latest firmware (Flight Control, Gimbal, Camera, Remote Controller, etc.) in one package from our official website. When a firmware update is available, you will be prompted by the app once it is connected to the aircraft.

---

### **IMPORTANT**

Before updating, make sure:

- The four **Motors** have stopped completely.
- The battery level of both your aircraft and remote controller is not less than 25%.
- There is sufficient space on your camera's SD card to store the firmware file.

---

### ● **Download and upgrade the firmware**

1. Download the all-in-one firmware upgrade package (with a .zip file extension) from Autel Robotics' official website: [www.autelrobotics.com](http://www.autelrobotics.com).
2. Insert the SD card into your computer and extract the downloaded file (into a .bin file extension) into your SD card. Then remove your SD card from the computer.
3. Insert the SD card into the aircraft to start the upgrade process automatically. You can check the real-time upgrade status displayed on the **Flight Information Panel**.
4. Turn on the remote controller and aircraft.
5. Reboot the remote controller and aircraft before use.

---

**!** **IMPORTANT**

- The upgrade process takes about 15 minutes. Do not turn off the aircraft or remote controller or remove your SD card from the camera during the process. Do not start the **Motors**.
  - After upgrading, the remote controller may be disconnected from the aircraft, and you may need to pair the devices again.
- 

## 5.2 Troubleshooting Tips

---

**Q1. When the aircraft indicates failure during self-check (with rear flight LEDs flashing red)**

- Hardware problems detected, contact the Customer Service

**Q2. When the aircraft **Motors** fail to start up**

- Verify the remote controller and the aircraft are properly bound
- Verify the remote controller is properly calibrated
- Verify the battery level is below 15%
- Verify the compass is experiencing interference
- Make sure GPS is available (if **Beginner Mode** is active)

**Q3. When takeoff fails after starting **Motors****

- Verify the aircraft is not in a no-fly zone
- Make sure the aircraft is placed on a flat, level surface

**Q4. When the aircraft's flight time reduces**

- This is possibly due to low temperature of the operating environment or increased takeoff weight

**Q5. When pairing up, the aircraft does not respond to the remote controller**

- Make sure there are no metal objects, wireless sources or other remote controllers around

**Q6. When Video link fails or disconnects frequently**

- Make sure your aircraft and remote controller are free from all magnetic or signal interference

**Q7. If the camera is powered off during video recording**

- Keep the Micro-SD card inside the camera. Restart the camera and wait until the video files are recovered (partial data may be lost)

#### **Q8. If the aircraft is out of sight and the video link is lost**

- Activate **Go Home** procedure to have the aircraft automatically return.

## **5.3 Storage and Maintenance Instructions**

---

To ensure optimum performance of the product, we suggest you read and follow the maintenance instructions in this section carefully.

- Keep the devices in a clean, dry and ventilated environment within normal operating temperatures.
- Keep the devices out of sunlight when not in use.
- Dry your hands before using the devices.
- Use a soft cloth with alcohol or a mild window cleaner to clean the lens of the camera, instead of any rough cleansers, detergent or chemicals.
- Ensure that the battery charger does not contact with conductive materials.
- Avoid dropping your devices, especially on a hard surface. Check it in detail after any crash or impact, and contact an Autel Robotics agent in time if you have any problem.
- Only use the battery chargers or other accessories authorized by Autel Robotics. Failure to do so may void the warranty.

## **5.4 Warranty**

---

Autel Robotics (the Company) warrants to the original retail purchaser of this product, that should this product or any part thereof during normal consumer usage and conditions, be proven defective in material or workmanship that results in product failure within the valid warranty period from the date of purchase, such defect(s) will be repaired, or replaced (with new or refurbished parts or products) at the Company's option, with Proof of Purchase, without charge for parts or labor directly related to the defect(s). Some states do not allow limitation on how long an implied warranty lasts, so the above limitations may not apply to you.

The Company shall not be liable for any incidental or consequential damages arising from the use, misuse, or mounting of the device. The extent of Autel Robotics' liability under this warranty is limited to the repair and replacement provided above and, in no event, shall its liability exceed the purchase price paid by purchaser for the product. Visit [www.autelrobotics.com](http://www.autelrobotics.com) for details of the limited periods warranted for the different parts of this product.

This warranty does not apply to:

- Batteries that cycle-charged for more than 200 times;

- Products subjected to abnormal use or environmental conditions, accident, mishandling, neglect, unauthorized alteration, misuse, improper installation or repair, or improper storage;
- Products with signs of tampering or altering of the serial number label, waterproof mark, etc.;
- Damage resulting from connection to, or use of any accessory or other product not approved or authorized by the Company;
- Defects in appearance, cosmetic, decorative or structural items such as framing and non-operative parts.
- Products damaged from external causes including but not limited to fire, water, dirt, sand, battery leakage, blown fuse, theft or improper usage of any electrical source.

## **5.5 Customer Service**

---

This section contains information regarding technical support, repair service, and application for replacements or optional parts.

### **5.5.1 Technical Support**

If you have any questions or concerns regarding our products, contact us by:

- Telephone: (844)-898-0290 (U.S.A.)
- Email: [support@autelrobotics.com](mailto:support@autelrobotics.com)
- In person: Local distributors or agents

### **5.5.2 Repair Service**

If it is necessary to return your device for repair, fill in and submit the repair service form on <http://www.autelrobotics.com>. The following information is required:

- Contact name
- Email address
- Mailing address
- Telephone number
- Product name
- Complete description of the problem with photo attachments
- Proof-of-purchase for warranty repairs
- Preferred method of payment for non-warranty repairs

Autel Robotics' support team will review your application within 72 hours after receiving your application. After a preliminary evaluation of the problem, our customer support will contact you for further updates or follow-ups.



## Chapter 6

# Appendix

## 6.1 Regulatory Compliance and Flight Restricted Area

---

### 6.1.1 Compliance and Advisory

#### FCC Compliance

##### FCC Warning Message

Any changes or modifications not expressly approved by the party responsible for compliance could void the user's authority to operate the equipment.

This device complies with part 15 of the FCC Rules. Operation is subject to the following two conditions: (1) This device may not cause harmful interference, and (2) this device must accept any interference received, including interference that may cause undesired operation.

##### FCC Radiation Exposure Statement:

###### For EVO Series / EVO

This equipment complies with FCC radiation exposure limits set forth for an uncontrolled environment. This equipment should be installed and operated with minimum distance 20cm between the radiator & your body. This transmitter must not be co-located or operating in conjunction with any other antenna or transmitter.

For EVO Series with model EF7, SAR tests are conducted using standard operating positions accepted by the FCC/ISED with the device. when used, please keep the distance with a minimum of 10mm from the body.

Note: This equipment has been tested and found to comply with the limits for a Class B digital device, pursuant to part 15 of the FCC Rules. These limits are designed to provide reasonable protection against harmful interference in a residential installation. This equipment generates uses and can radiate radio frequency energy and, if not installed and used in accordance with the instructions, may cause harmful interference to radio communications. However, there is no guarantee that interference will not occur in a particular installation. If this equipment does cause harmful interference to radio or television reception, which can be determined by turning the equipment off and on, the user is encouraged to try to correct the interference by one or more of the following measures:

- Reorient or relocate the receiving antenna.
- Increase the separation between the equipment and receiver.
- Connect the equipment into an outlet on a circuit different from that to which the receiver is connected.
- Consult the dealer or an experienced radio/TV technician for help.

### ISED RSS warning

This device complies with ISED licence-exempt RSS standard (s). Operation is subject to the following two conditions: (1) this device may not cause interference, and (2) this device must accept any interference, including interference that may cause undesired operation of the device.

Le présent appareil est conforme aux CNR d'Industrie Canada licables aux appareils radio exempts de licence.

L'exploitation est autorisée aux deux conditions suivantes:

(1) l'appareil ne doit pas produire de brouillage, et

(2) l'utilisateur de l'appareil doit accepter tout brouillage radioélectrique subi, même si le brouillage est susceptible d'en compromettre le fonctionnement.

### ISED Radiation Exposure Statement:

For EVO Series / EVO

This equipment complies with ISED RF radiation exposure limits set forth for an uncontrolled environment.

This transmitter must not be co-located or operating in conjunction with any other antenna or transmitter.

This equipment should be installed and operated with minimum distance 20cm between the radiator& your body.

For EVO Series with model EF7, SAR tests are conducted using standard operating positions accepted by the FCC/ISED with the device. when used, please keep the distance with a minimum of 10mm from the body.

Any Changes or modifications not expressly approved by the party responsible for compliance could void the user's authority to operate the equipment.

## 6.1.2 Flight Restricted Area Illustration

The EVO system automatically recognizes the Flight Restricted Area, in which flights are limited by default. This feature guarantees pilots' safe and legal operations of the product. The flight restricted areas are divided into 2 protection categories.

Flight restrictions are enforce only within countries which require manufacturer restrictions by law. Currently only the country China requires manufactures to enforce flight restrictions.



### NOTE

The pilot is responsible to ensure they are following all flight rules and regulations in the areas they fly.

---

**Category I:** Major airports and flight areas where drones operate at low altitudes

- **Take-off Restricted Zones (No-Fly Zones)**

These areas are set within 2.4km (based on country imposed rules) around the midway point of specified locations.

- **Altitude Restricted Zones**

In these areas, the aircraft is only allowed to fly within limited altitudes. From 8km to 2.4km (based on country imposed rules) around the locations midway point, the flight altitude decreases progressively from 120m to 10.5m.

- **Warning Zones**

Once the aircraft enters a region within 8.1 km from the central point of the airport, the app will prompt a warning message.

---

 **NOTE**

The aircraft will land automatically when entering any **Take-off Restricted Zones**. If the aircraft enters any **Altitude Restricted Zones**, its maximum allowable altitude will be reduced accordingly. Pay special attention to the warning messages displayed on your app.

---

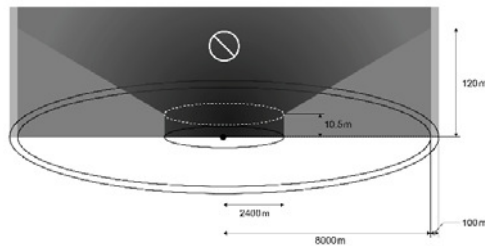

**Category II:** Sensitive areas and institutes such as military sites and border lines between countries

- **Take-off Restricted Zones (No-Fly Zones)**

These areas are set within 1km around the center of the specified sites where takeoff and flight are prohibited.

- **Warning Zone**

Once the aircraft enters the region within 2km from the center of the site, the app will prompt a warning message.

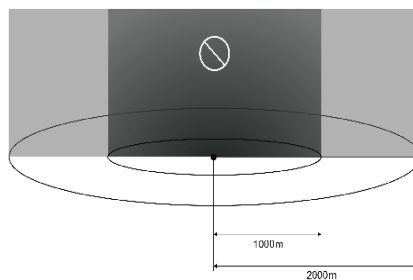

## 6.2 Specifications

<i>Aircraft Specifications</i>	
Hover Precision	GPS+ Ultrasonic+IMU: Horizontal: $\pm 1.5\text{m}$ , Vertical: $\pm 0.2\text{m}$ ; Vision+IMU: Horizontal: $\pm 0.1\text{m}$ , Vertical: $\pm 0.1\text{m}$
Max Yaw Rate	200 dps
Max Inclination Angle	35 deg
Max Ascent/Descent Speed	Ascent: 5m/s Descent: 3m/s
Max Horizontal Speed	20 m/s
Diagonal Wheelbase	338 mm
Propeller Size	8.3 inches
Video Link Frequency	2.4GHz~2.4835GHz
	902MHz~928MHz
Receiver Frequency	2.4GHz~2.4835GHz 902MHz~928MHz
Flight Modes	GPS Mode, Sport Mode, ATTI Mode
Operating Environment Temperature	0°C~40°C (32°F~104°F)
Storage Temperature	-10°C~40°C (14°F~104°F)
Weight (Battery & Propellers included)	863 g

<i>Aircraft Battery Specifications</i>	
Battery Type	Lithium-Polymer
Capacity	4300 mAh
Battery Voltage	11.4 V
Charging Environment Temperature	10°C~45°C (50°F~113°F)
Discharging Environment Temperature	-20°C~60°C (-4°F~140°F)
Storage Temperature & Humidity	Temp: -10°C~40°C (14°F~104°F)
	Humidity: 65 $\pm$ 20%RH
Flight Time	30 mins

<i>Camera Gimbal Specifications</i>	
Operating Current	150mA@12V (Non-video Mode)
Input Voltage	12 V

Operating Temperature	-10°C~50°C(14°F~122°F)
Weight	67.5g (Camera incl.)
Dimensions (Damping Device excl.)	42m x 49mm x 45mm
Control Accuracy	Pitch: ±0.015° Roll: ±0.015° Yaw: ±0.015°
Max. Angular Velocity	Pitch: ±200°/S Yaw: ±200°/S
Controllable Range	Pitch: 0°~90° Yaw: ±50°

### *Camera Specifications*

Operating Environment Temperature	0°C~40°C (32°F~104°F)
Still Photography Modes	Single shot Burst shooting Auto Exposure Bracketing (AEB) Time-lapse
Video Recording Modes	Normal
Max. Field of View	94°
Supported SD Card Types	Micro-SD card
Storage capacity	4GB-128GB
File Formats	FAT32/exFAT Photo: JPG/DNG Video: MOV/MP4

### *Remote Controller Specifications*

RF Receiver Operating Frequency	2.4GHz~2.4835GHz 902MHz~928MHz
Video Link Frequency	2.4GHz~2.4835GHz
	902MHz~928MHz
Operating Temperature	0°C~40°C (32°F~104°F)
Storage Temperature	1 year: -20°C~25°C(-4°F~77°F) 3 months: -20°C~45°C(-4°F~113°F)
Max Control and Video Transmission Distance	7km
Transmission Power (EIRP)	FCC: ≤26 dBm CE: ≤20 dBm
Operating Current/Voltage	2A @ 3.6V
Battery	6700mAh
Power Consumption	7.2W
Weight (battery included)	370g