

Dragonfish Pro

Quick Start Guide

Contents

Item list

Getting to know the aircraft

Getting to know the mobile ground station

Getting to know the base station

Using the Dragonfish Pro aircraft

Charging

Setting up the base station

Assembling the aircraft

Powering on / Activating the aircraft

Powering on the base station

Powering on the ground station

Powering on the aircraft

Activating the aircraft

Flight

Activating the aircraft

Automatic takeoff

Specifications

Item list

	Aircraft body x1		9.7-inch ground station x1
	Base station x1		Battery x4 (the actual quantity is subject to the purchased set)
	Charger + AC line x1		Propeller blades x2
	Base station antenna x2		Base station feeder x2
	Base station tray x1		Base station tripod (x1)

	Base station charger x1		USB Type-C cable x1
	Repair tool kit x1		Gimbal Camera x1 (The gimbal model is subject to the actual set purchased)
	Wing set x1		Ground station lanyard x1
	Tail x1		Documentation x 1 set (includes Dragonfish Pro, Base station, Charger, Battery quick guide, Disclaimer)
	Ground station charger x1		

Getting to know the aircraft

The Dragonfish Pro aircraft integrates Autel Robotics' intelligent and superior flight control technology, gimbal technology, and imaging technology. The aircraft boasts a new tilt rotor design that combines the efficiency of fixed-wing aircraft endurance with the takeoff convenience of traditional multi-rotor drones. A 5 second self-check system ensures the aircraft is safe and ready for operation. It can be assembled quickly, enabling set up and take-off in a matter of minutes.

The Dragonfish Pro offers a maximum flight time of up to 180 minutes and a video transmission range of 30 km. It comes built in with a range of intelligent features such as automatic take-off and landing, intelligent tracking, terrain follow and more.

Tough and reliable, the Dragonfish Pro has an IP43 protection rating to enable operations across a variety of terrains. It also features a modular payload mount with an integrated quick release function that enables operators to mount a dual sensor, a triple sensor, or a multispectral payload effortlessly to suit mission needs.

Alongside the aircraft is a GNSS Base Station and the integrated, Dual RTK modules that equip the aircraft with additional redundancy. This allows the Dragonfish Pro to fly confidently in complex environments while capturing precise, centimeter-accurate data.

1. RTK antenna
2. Propeller blades
3. Smart battery
4. Power button/indicator
5. Wing lock
6. Body motor

7. Gimbal camera
8. Battery release button
9. Front landing gear
10. Rear landing gear
11. Wingtip propellers
12. Wing motor
13. Horizontal stabilizer
14. Airspeed sensor
15. Tilting wingtip
16. GPS module
17. Ultrasonic Positioning Sensors
18. Dust Net
19. Gimbal installation interface

Getting to know the portable ground station

The Dragonfish Pro is equipped with a 9.7-inch TFT-LCD touch screen (2048*1536). It offers a brightness of 1000 cd/m², making it almost twice as bright as typical mobile devices. The screen can display images clearly even in direct sunlight, and a built-in 256G memory makes it convenient for storing all your critical data. With an image transmission range of 30km and a battery life of 4.5 hours, the ground station guarantees optimal performance and reliability.

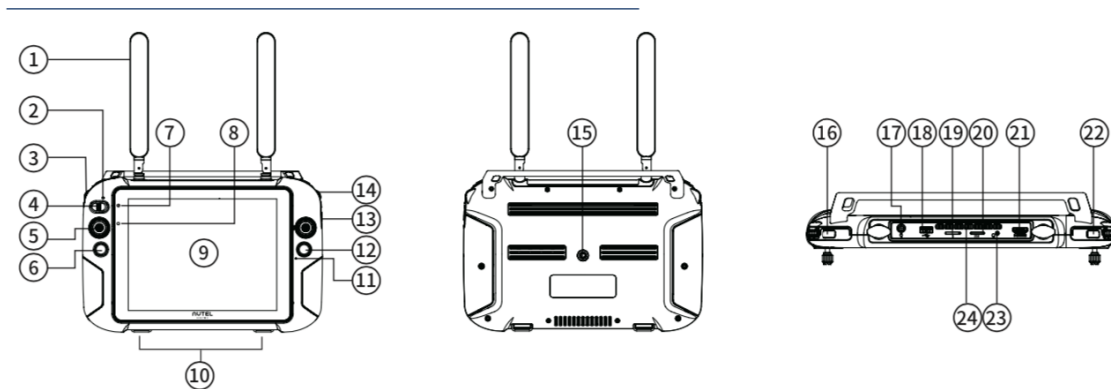

1. Antenna
2. Mode switch indicator
3. Gimbal pitch control wheel
4. Manual/Auto mode switch key
5. Joystick
6. Home button
7. Power status indicator
8. Light perception sensor
9. Touch screen
10. Hooks (for lanyard support)
11. Microphone

12. Photo/Video button
13. Zoom button
14. Gimbal level control dial
15. Tripod mounting interface
16. Power button
17. Charging port
18. USB port
19. SD card slot
20. SIM card slot
21. HDMI port
22. Custom buttons
23. Headphone jack
24. Air outlet

Getting to know the base station

The Dragonfish base station is a high-precision satellite signal receiver that supports GPS, Beidou, Galileo and GLONASS navigation systems. It can be used across a variety of applications and environments. The base station and the integrated, Dual RTK modules equip the aircraft with additional redundancy and positioning accuracy to provide precise, centimeter accurate data. It also enables the Dragonfish Pro to withstand signal interference in strong magnetic environments such as power lines and near buildings.

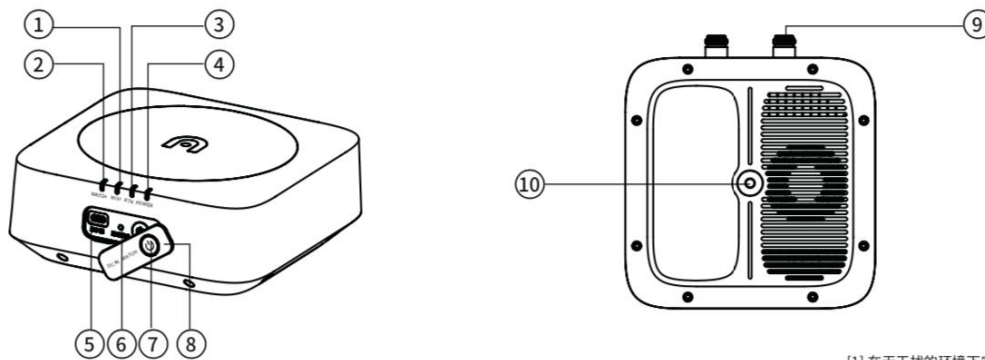

4

[1] 在无干扰的环境下实验数据测得

1. WiFi indicator
2. Linking indicator
3. RTK indicator
4. Power indicator
5. Charging port
6. Frequency button
7. Power button
8. Port cover

9. Antenna interface

10. Tripod interface

Using the Dragonfish Pro

Charging	Setting up the base station
1. Charging the Intelligent flight battery	1. Unfold the tripod, install the base station tray, and lock the tray.
2. Charging the ground station	2. Install the base station body to the tray and tighten the lock on the tray nut. Ensure that the base station is level and stable.
3. Charging the base station	3. Install the antenna on the tripod and connect the antenna feeder to the base station antenna port.

使用您的龙鱼

充电

1. 智能飞行电池充电

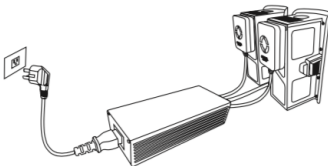

2. 地面站充电

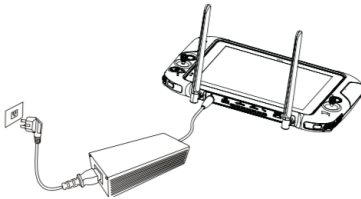

3. 基站充电

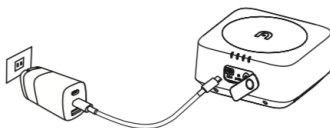

架设基站

1. 展开三脚架，安装基站托盘，锁紧托盘。

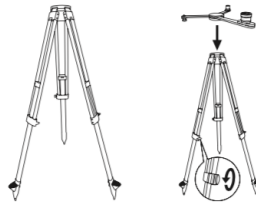

2. 安装基站主体至托盘，拧紧托盘上的锁定螺母。确保基站水平且稳固。

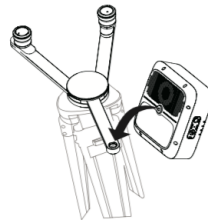

3. 将天线安装至三脚架，并将天线馈线连接到基站天线端口。

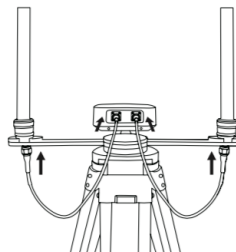

Charging

1. Charging the intelligent aircraft battery
2. Charging the ground station
3. Charging the base station

Setting up the base station

1. Unfold the tripod, install the base station tray, and lock it.
2. Install the base station body to the tray and tighten the lock on the tray nut. Ensure that the base station is level and stable.
3. Install the antenna on the tripod and connect the antenna feeder to the base station antenna port.

Assembling the aircraft

1. Install the left and right wings

(对齐扣紧)-Align and fasten

2. Install the tail

(对齐扣紧)-Align and fasten

3. Install the wingtip propeller

Before installing or removing the propeller, power off the aircraft (as shown in the illustration).

4. Mounting

Align the red dots on the mount with the red dots of the gimbal interface of the fuselage, and rotate the lock to the locked position.

1. Align the top and bottom red dots
2. Insert the gimbal up vertically into the slot
3. Rotate the lock ring to the locked position

5. Unlock mount

1. Press the unlock button
2. Rotate the lock ring to the unlocked position
3. Remove mount by lowering vertically down

6. Installing the intelligent Flight Battery

When installing or removing the aircraft battery, be sure to power off the aircraft.

- Align the battery to the battery interface on the fuselage and install it.

3. 安装翼尖螺旋桨

安装或拆卸螺旋桨之前，应先关闭飞行器电源开关（图示为有标记的螺旋桨与有标记电机底座安装过程）

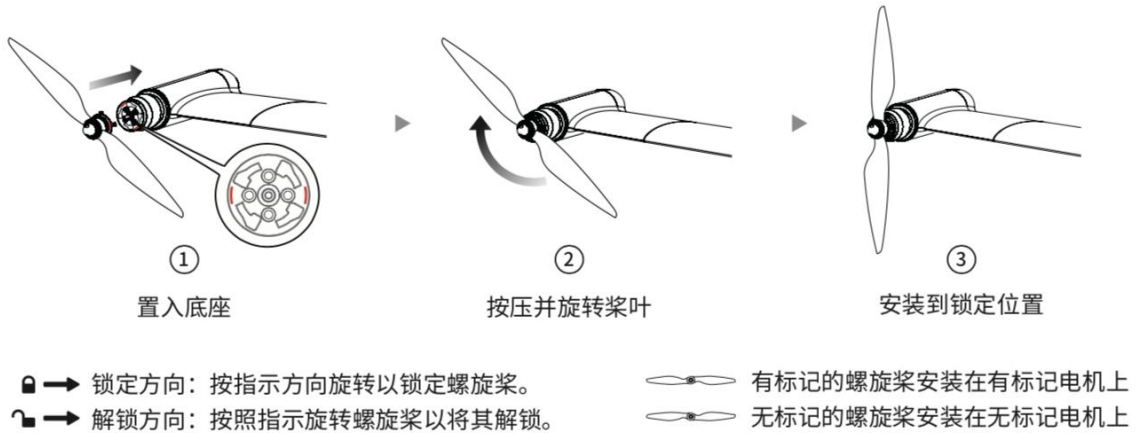

6

1. Mount on the base
2. Press and rotate the paddle
3. Install to the locked position

Locking direction: Press and Rotate in the indicated direction to lock the propeller.

Unlocking direction: Press and Rotate the propeller in the opposite direction to unlock it.

The marked propeller is to be mounted on the marked motor

Unmarked propeller is to be mounted on the unmarked motor

4. 安装挂载

对齐挂载上的红点与机身云台接口红点，旋转锁环到锁定位置

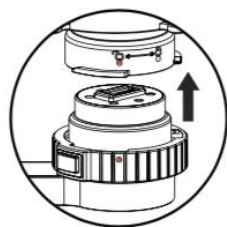

①

对齐上下红点



②

置入卡位



③

旋转锁环到锁定位置

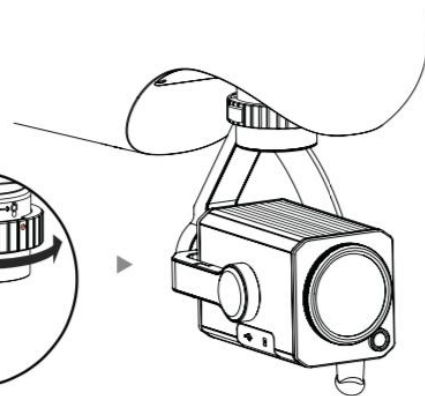

5. 解锁挂载



①

按下解锁按键



②

旋转锁环到解锁位置

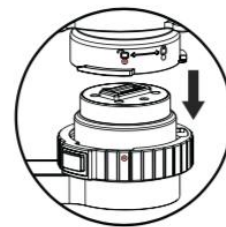

③

向下取下挂载

6. 安装智能飞行电池

安装或拆卸飞行器电池时，请务必关闭飞行器电源。

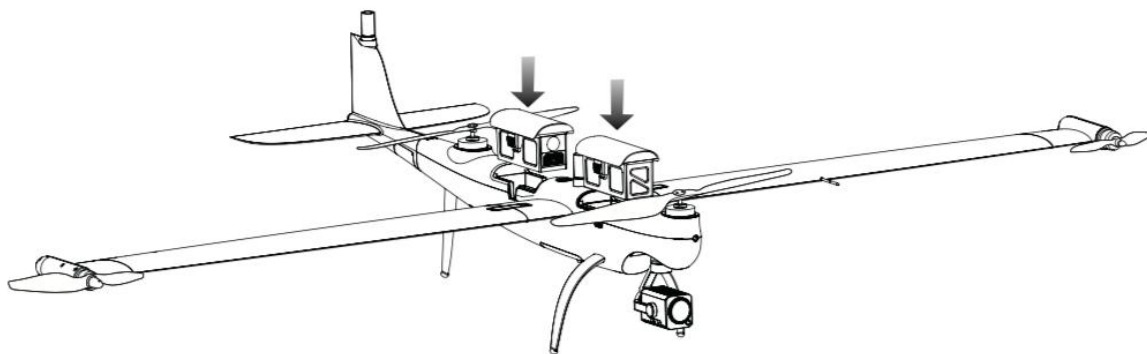

• 对准身上的电池接口，安装电池

开启电源 | 激活飞行器

1. 开启基站电源

短按电源键 1 秒开启基站



3. 开启飞行器电源

短按机身电源按键 3 秒开启飞行器电源

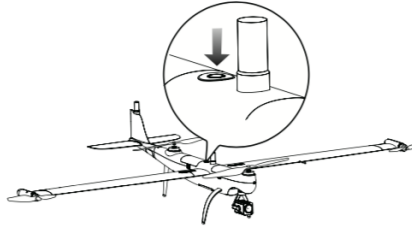

2. 开启地面站电源

短按电源按键 1 秒开启地面站电源

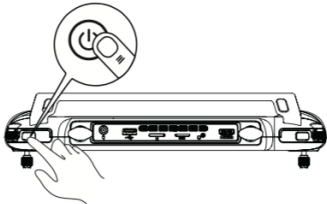

4. 激活飞行器

打开 Autel Voyager，点击激活按钮，激活飞行器。



Powering on / Activating the aircraft

1. Powering on the base station

Short press the power button for 1 second to turn on the base station.

2. Powering on the ground station

Short press the power button for 1 second to turn on the ground station.

3. Powering on the aircraft

Press the power button on the aircraft body for 3 seconds to power on the aircraft.

4. Activating the aircraft

Open Autel Voyager and click the activation button to activate the aircraft.

飞行

进入 Autel Voyager 安全飞行界面显示。起飞前，请将飞行器置于平坦地面，并使机尾朝向自己。

手动起飞

① 将地面站档位切换至 M 档

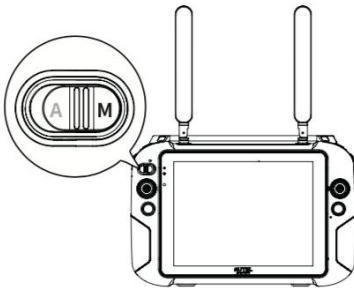

② 飞行器系统状态检查

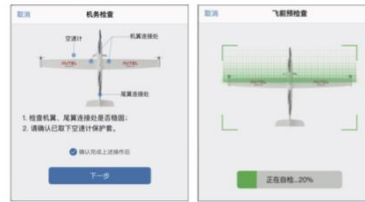

③ 同时内八或外八方式扳动摇杆并停留 2 秒解锁电机

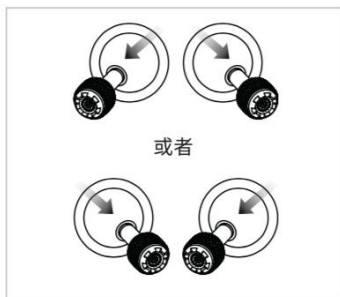

④ 向上推动左侧摇杆 (模式 2) 飞行器上升



* 非专业人士不建议使用手动模式

Flight

Enter the Autel Voyager safe flight interface. Before taking off, please place the aircraft on a flat surface with the tail facing towards you.

Manual takeoff

1. Switch the ground station gear to M gear.
2. Check the aircraft system status.
3. Simultaneously move the joystick in inwards or outwards and hold for 2 seconds to arm the motors.
4. Push up the left stick (mode 2) to take off.

Automatic takeoff

1. Switch the ground station gear to A gear
2. Click the Create Mission button to plan the mission
3. Aircraft system status check
4. Flight interface display

8. Specifications

Aircraft

Size	1.65x3.04x0.46 m
Weight (including two batteries, without gimbal)	14.5 kg
Single battery weight	3.6 kg
Maximum load	2.5 kg
Maximum take-off weight	17.0 kg
Working frequency	902-928 MHz , 2.4000-2.4835 GHz , 5.725-5.755GHz
Maximum angular velocity	Pitch: 180° /s Yaw: 60° /s
Maximum pitch angle	20°
Maximum roll angle	35°

Maximum ascent speed	Vertical flight mode: 4 m/s Fixed-wing flight mode: 5 m/s
Maximum descent speed (vertical)	Vertical flight mode: 3 m/s Fixed-wing flight mode: 5 m/s
Maximum horizontal flight speed	0~17 m/s (multi-rotor) 17~30 m/s (fixed-wing)
Maximum service altitude	6000 m
Maximum wind resistance	During fixed-wing flight: 15 m/s (level 7 wind) Vertical take-off and landing: 12 m/s (level 6 wind)
Maximum flight time	180 min
Supported Payloads	DG-Z2, T3, T3H, L20T, M1
Supported Gimbal Configurations	Fast Disassembly
Ingress Protection Rating	IP43
GNSS	GPS + GLONASS + BeiDou + Galileo
Working temperature	-20° C to 50° C
EIRP (Equivalent radiated power)	900 MHz FCC: <30 dBm; 2.4 GHz FCC: <30 dBm SRRC/CE/MIC: <20 dBm; 5.8 GHz SRRC/FCC: <22 dBm CE: <14 dBm hovering accuracy (P-GPS)
Hovering accuracy (P-GPS)	Vertical: ±0.1 m (when the visual positioning is working normally) ±0.5 m (when GPS is working normally) ±0.1 m (when RTK positioning is working normally) Horizontal: ±0.3 m (when visual positioning is working normally) ±1.5 m (when GPS is working normally)

	±0.1 m (when RTK positioning is working normally)
RTK positioning accuracy	When RTK enabled and fixed: Multi-rotor: 1 cm+1 ppm (Horizontal) 1.5 cm + 1 ppm (Vertical) Fixed Wing: 3 cm+1 ppm (Horizontal) 3 cm + 1 ppm (Vertical)

9.7 inch ground control station

Image transmission parameters:	Working frequency	902-928 MHz; 2.4-2.4835 GHz
	Maximum transmitting distance (unobstructed, free of interference)	FCC:10 km CE / MIC:5 km SRRC:5 km
Digital transmission	Working frequency	5.725 - 5.755 GHz
Wi-Fi parameters:	Protocol	Wi-Fi Direct, Wi-Fi Display, 802.11a/g/n/ac Supports 2 x 2 MIMO Wi-Fi
	Working efficiency	2.400 - 2.4835 GHz 5.150 - 5.250GHz 5.650 - 5.755GHz 5.725 - 5.850 GHz
Other parameters:	Battery	Name: Lithium polymer Battery Capacity: 8200mAh Voltage: 11.4 V Battery type: Li-Po Energy: 93 Wh Charging time: 120 minutes
	Battery life	Approximately 3 hours (maximum brightness) Approximately 4.5 hours (50% brightness)
	Storage	ROM 256GB + expandable (support TF card)
	Video output interface	HDMI interface

	USB-A interface supply voltage/current	5V / 500m A
	Working temperature	-20°C to 40°C
	Storage temperature	-20°C to 60°C (within one month) -20°C to 45°C (within three months) -20°C to 30°C (within one year)
	Charging environment temperature	0°C to 45°C
	Satellite positioning module	GPS + GLONASS + Galileo
	Size	319x233x74 mm (antenna folded) 319x398x74 mm (antenna expanded)
	Weight	1987 g

Base station

GNSS receiver	Satellite receiving frequency	Simultaneously receive: GPS: L1, L2, L5 BeiDou: B1, B2, B3 GLONASS: F1, F2 Galileo: E1, E5A, E5B
	Positioning accuracy	Single Point Horizontal: 1.5 m (RMS) Vertical: 3.0 m (RMS) RTK Horizontal: 1 cm+1 ppm (RMS) Vertical: 1.5 cm + 1 ppm (RMS) 1 ppm: For every 1 km increase in distance, the accuracy will be 1 mm less. For example, the horizontal accuracy is 1.1 cm when the

		receiving end is 1 km away from the base station.
	Positioning update rate	1 Hz , 2 Hz , 5 Hz , 10 Hz and 20Hz
	Cold start	< 40 s
	Hot Start	< 10 s
	Recapture Initialization reliability	< 1 s
	Initialization reliability	> 99.9%
	Differential data transmission format	RTCM 2.X/3.X
Communication	Data link	Image transmission, Wi-Fi
Image transmission parameters:	Working efficiency	902-928 MHz; 2.4000-2.4835 GHz
	EIRP (Equivalent radiated power)	902-928 MHz FCC:< 30 dBm 2.400-2.4835 GHz FCC:< 30 dBm SRRC/CE/MIC:< 20 dBm
WIFI parameters:	Working efficiency	2.400-2.4835 GHz; 5.125-5.25GHz 5.650-5.755GHz; 5.725-5.850GHz
	EIRP (Equivalent radiated power)	2.400-2.4835 GHz FCC:< 26 dBm SRRC/CE/MIC:< 20 dBm 5.125-5.25GHz FCC/SRRC:< 26dBm 5.650-5.755GHz MIC:< 20 dBm 5.725-5.850GHz SRRC/FCC:< 26 dBm;

	Communication distance	CE: < 14 dBm SRRC/CE/MIC:< 20 dBm Base station and aircraft: 30km (FCC) Base station and ground station: 200m (FCC) (Unobstructed and free of interference, when the mobile station is used as a base station and the distance from the mobile station antenna to the bottom of the tripod is 2 m; and when the difference in height between the remote controller and mobile station is less than 10 m, and when the remote controller is 1.2 m from ground level)
Electrical characteristics	Power consumption	7.5W
	Power supply	5 to 20V DC
	Battery	Type: Lithium polymer battery Capacity: 4950 mAh Energy: 57.1 WH
	Runtime	> 7.5 h
Physical properties	Dimensions (base station body + extension rod)	193 mm×177 mm×73 mm
	Weight	1275g
	Ingress protection	IP64
Working temperature		-20°C to 50°C

DG-Z2		
Zoom camera	Effective Pixels	3840x2160 8M

	Zoom	20x zoom, 12x digital zoom, 240x total magnification
	Aperture	F2.0 (wide) to 3.8 (tele)
	Photo Resolution	3840x2160 8M
	Photo	JPEG
	Video Resolution	3840x2160 8M 1920x1080 20M
	Video	MP4
Wide-angle camera	Effective Pixels	4000x3000 12MP
	Zoom	1-8x digital zoom
	Photo Resolution	4000x3000 12MP
	Photo	JPEG
	Video Resolution	3840x2160 8M 1920x1080 20MP
	Video	MP4
DG-T3		
Zoom camera	Effective Pixels	3840x2160 8M
	Zoom	20x zoom, 12x digital zoom, 240x in total
	Aperture	F2.0 (wide) to 3.8 (tele)
	Photo Resolution	3840x2160 8M
	Photo	JPEG
	Video Resolution	3840x2160 8M 1920x1080 20M

	Video	MP4
Wide-angle camera	Effective Pixels	4000x3000 12M
	Zoom	1-8x digital zoom
	Photo Resolution	4000x3000 12M
	Photo	JPEG
	Video Resolution	3840x2160 8M 1920x1080 20M
	Video	MP4
Thermal Camera	Infrared camera sensor	Uncooled VOx Microbolometer
	Sensor Resolution	640*512
	Zoom	1-8x digital zoom
	Pixel Pitch	12μm
	Spectral Band	8-14μm
	Lens	25mm F1.0
	FOV	17°×14°
	Photo Resolution	640*512
	Photo	JPEG
	Video Resolution	640*512
	Frame Rate	30Hz
	Video	MP4
	Accuracy	±3°C or ±3% of reading (whichever is greater) @ambient temperature - 20°C~60°C

	Scene Range	High Gain: -20° to +150°C Low Gain: 0°to +550°C
--	-------------	--

FCC Statement

1. This device complies with Part 15 of the FCC Rules. Operation is subject to the following two conditions:

(1) This device may not cause harmful interference.

(2) This device must accept any interference received, including interference that may cause undesired operation.

2. Changes or modifications not expressly approved by the party responsible for compliance could void the user's authority to operate the equipment.

NOTE:

This equipment has been tested and found to comply with the limits for a Class B digital device, pursuant to Part 15 of the FCC Rules. These limits are designed to provide

reasonable protection against harmful interference in a residential installation.

This equipment generates uses and can radiate radio frequency energy and, if not installed and used in accordance with the instructions, may cause harmful interference to radio communications. However, there is no guarantee that interference will not occur in a particular installation. If this equipment does cause harmful interference to radio or television reception, which can be determined by turning the equipment off and on, the user is encouraged to try to correct the interference by one or more of the following measures:

Reorient or relocate the receiving antenna.

Increase the separation between the equipment and receiver.

Connect the equipment into an outlet on a circuit different from that to which the receiver is connected.

Consult the dealer or an experienced radio/TV technician for help.

SAR Information Statement

Your wireless phone is a radio transmitter and receiver. It is designed and manufactured not to exceed the emission limits for exposure to radiofrequency (RF) energy set by the Federal Communications Commission of the U.S. Government. These limits are part of comprehensive guidelines and establish permitted levels of RF energy for the general population. The guidelines are based on standards that were developed by independent scientific organizations through periodic and thorough evaluation of scientific studies. The standards include a substantial safety margin designed to assure the safety of all persons, regardless of age and health. The exposure standard for wireless mobile phones employs a unit of measurement known as the Specific

Absorption Rate, or SAR. The SAR limit set by the FCC is 1.6 W/kg. * Tests for SAR are conducted with the phone transmitting at its highest certified power level in all tested frequency bands. Although the SAR is determined at the highest certified power level, the actual SAR level of the phone while operating can be well below the maximum value. This is because the phone is designed to operate at multiple power levels so as to use only the power required to reach the network. In general, the closer you are to a wireless base station antenna, the lower the power output. Before a phone model is available for sale to the public, it must be tested and certified to the FCC that it does not exceed the limit established by the government adopted requirement for safe exposure. The tests are performed in positions and locations (e.g., at the ear and worn on the body) as required by the FCC for each model. The highest SAR value

for this model phone when tested for use on the body, as described in this user guide, is 1.108W/Kg(Body-worn measurements differ among phone models, depending upon available accessories and FCC requirements). While there may be differences between the SAR levels of various phones and at various positions, they all meet the government requirement for safe exposure. The FCC has granted an Equipment Authorization for this model phone with all reported SAR levels evaluated as in compliance with the FCC RFexposure guidelines. SAR information on this model phone is on file with the FCC and can be found under the Display Grant section of <http://www.fcc.gov/oet/fccid> after searching on FCC ID: 2AGNTDFRC2TBA Additional information on Specific Absorption Rates (SAR) can be found on the Cellular Telecommunications Industry Association (CTIA) web-site at <http://www.wow-com.com>. *

In the United States and Canada, the SAR limit for mobile phones used by the public is 1.6 watts/kg (W/kg) averaged over one gram of tissue. The standard incorporates a substantial margin of safety to give additional protection for the public and to account for any variations in measurements.

Body-worn Operation

This device was tested for typical body-worn operations. To comply with RF exposure requirements, a minimum separation distance of 10mm must be maintained between the user's body and the handset, including the antenna. Third-party belt-clips, holsters, and similar accessories used by this device should not contain any metallic components. Body-worn accessories that do not meet these requirements may not comply with RF exposure requirements and should be avoided. Use only the supplied or an approved antenna.

IC STATEMENT

This device complies with Industry Canada licence-exempt RSS standard(s)

Operation is subject to the following two conditions:

- (1) This device may not cause interference, and**
- (2) This device must accept any interference, including interference that may cause undesired operation of the device.**

This equipment complies with IC radiation exposure limits set forth for an uncontrolled environment. End user must follow the specific operating instructions for satisfying RF exposure compliance. This transmitter must not be co-located or operating in conjunction with any other antenna or transmitter.

These requirements set a SAR limit of 1.6 W/kg averaged over one gram of tissue.

when worn on the body is 1.108W/Kg. This device was tested for typical body-worn

operations. To comply with RF exposure requirements, a minimum separation distance of 15mm must be maintained between the user's body and the handset, including the antenna. Third-party belt-clips, holsters, and similar accessories used by this device should not contain any metallic components. Body-worn accessories that do not meet these requirements may not comply with RF exposure requirements and should be avoided. Use only the supplied or an approved antenna.

Le présent appareil est conforme aux CNR d'Industrie Canada applicables aux appareils radio exempts de licence.

5150-5250MHz is only for indoor use

Ce dispositif est conforme aux normes autoriser-exemptes du Canada RSS d'industrie

L'exploitation est autorisée aux deux conditions suivantes :

(1) l'appareil ne doit pas produire de brouillage, et

(2) l'utilisateur de l'appareil doit accepter tout brouillage radioélectrique subi, même si le brouillage est susceptible d'en compromettre le fonctionnement. Cet équipement

est conforme avec l'exposition aux radiations IC définies pour un environnement

non contrôlé. L'utilisateur final doit respecter les instructions de fonctionnement spécifiques

pour satisfaire la conformité aux expositions

RF. Cet émetteur ne doit pas être co-localisées

ou opérant en conjonction avec une autre

antenne ou transmetteur. Ces exigences

définissent

la valeur SAR limite à 1.6 W / kg en moyenne

par gramme de tissu. La valeur SAR la plus

et lorsque porté sur le corps est 1.108W/Kg.

Cet appareil a été testé pour des opérations portés sur le corps typiques. Pour se conformer aux exigences d'exposition aux radiofréquences, une distance minimale de 15 mm doit être maintenue entre le corps de l'utilisateur et le combiné, y compris l'antenne. Les pinces de ceinture, les étuis et autres accessoires similaires utilisés par cet appareil ne doivent pas contenir de composants métalliques. Les accessoires portatifs qui ne répondent pas à ces exigences peuvent ne pas se conformer aux exigences d'exposition RF et doit être évitée. Utilisez uniquement l'antenne fournie ou une antenne approuvée

5150-5250MHz is only for indoor use