



RADIO TEST REPORT

Report No: STS2209045W01

Issued for

BTECH (BaoFeng Tech)

702 N Industrial Ave Arlington South Dakota United States
57212

Product Name:	Two way radio
Brand Name:	BTECH
Model Name:	MURS-V2
Series Model:	N/A
FCC ID:	2AGND-MURS-V2
Test Standard:	FCC Part 95

Any reproduction of this document must be done in full. No single part of this document may be reproduced without permission from STS, all test data presented in this report is only applicable to presented test sample.





TEST REPORT CERTIFICATION

Applicant's Name: BTECH (BaoFeng Tech)
 Address.....: 702 N Industrial Ave Arlington South Dakota United States
 57212
 Manufacturer's Name.....: BTECH (BaoFeng Tech)
 Address.....: 702 N Industrial Ave Arlington South Dakota United States
 57212
 Product Description
 Product Name.....: Two way radio
 Brand Name.....: BTECH
 Model Name: MURS-V2
 Series Model.....: N/A
 Test Standards: FCC Part 95
 Test Procedure.....: TIA 603-E

This device described above has been tested by STS, the test results show that the equipment under test (EUT) is in compliance with the FCC requirements. And it is applicable only to the tested sample identified in the report.
 This report shall not be reproduced except in full, without the written approval of STS, this document only be altered or revised by STS, personal only, and shall be noted in the revision of the document.

Date of Test.....:
 Date of receipt of test item.....: 09 Sept. 2022
 Date of performance of tests: 09 Sept. 2022 ~ 06 Jan. 2023
 Date of Issue.....: 06 Jan. 2023
 Test Result: **Pass**

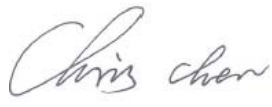
Testing Engineer : 

 (Chris chen)

Technical Manager : 

 (Sean she)

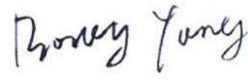
Authorized Signatory : 

 (Bovey Yang)





Table of Contents

1. SUMMARY OF TEST RESULTS	6
1.1 TEST FACTORY	7
1.2 MEASUREMENT UNCERTAINTY	7
2. GENERAL INFORMATION	8
2.1 GENERAL DESCRIPTION OF THE EUT	8
2.2 DESCRIPTION OF THE TEST MODES	9
2.3 BLOCK DIAGRAM SHOWING THE CONFIGURATION OF SYSTEM TESTED	10
2.4 DESCRIPTION OF NECESSARY ACCESSORIES AND SUPPORT UNITS	11
2.5 EQUIPMENTS LIST	12
3. FIELD STRENGTHS AND RADIATED SPURIOUS EMISSION	14
3.1 RADIATED EMISSION LIMITS	14
3.2 TEST PROCEDURE	15
3.3 TEST SETUP	16
3.4 EUT OPERATING CONDITIONS	16
3.5 TEST RESULT	17
4. SPURIOUS EMISSION ON ANTENNA PORT	25
4.1 LIMIT	25
4.2 TEST PROCEDURE	25
4.3 TEST SETUP	26
4.4 EUT OPERATION CONDITIONS	26
4.5 TEST RESULT	26
5. TRANSMITTER OUTPUT POWER	29
5.1 LIMIT	29
5.2 TEST PROCEDURE	29
5.3 TEST SETUP	29
5.4 TEST RESULTS	29
6. BANDWIDTH TEST	30
6.1 LIMIT	30
6.2 TEST PROCEDURE	30
6.3 TEST SETUP	30
6.4 EUT OPERATION CONDITIONS	30
6.5 TEST RESULTS	31
7. EMISSION MASK	35



Table of Contents

7.1 LIMIT	35
7.2 TEST PROCEDURE	35
7.3 TEST SETUP	36
7.4 EUT OPERATION CONDITIONS	36
7.5 TEST RESULT	37
8. FREQUENCY STABILITY	40
8.1 LIMIT	40
8.2 TEST PROCEDURE	40
8.3 TEST SETUP	40
8.4 EUT OPERATION CONDITIONS	40
8.5 TEST RESULT	41
9. MURS AUDIO FILTER	42
9.1 LIMIT	42
9.2 TEST PROCEDURE	42
9.3 TEST SETUP	42
9.4 TEST RESULT	43
APPENDIX 1- PHOTOS OF TEST SETUP	45



Revision History

Rev.	Issue Date	Report NO.	Effect Page	Contents
00	06 Jan. 2023	STS2209045W01	ALL	Initial Issue





1. SUMMARY OF TEST RESULTS

Test procedures according to the technical standards:

FCC Part 95			
Standard Section	Test Item	Judgment	Remark
FCC Part 95.2779	MURS unwanted emissions limits	PASS	--
FCC Part 95.2767	MURS transmitting power	PASS	--
FCC Part 95.2773	MURS authorized bandwidths	PASS	--
FCC Part 95.2779	Emission mask	PASS	--
FCC Part 95.2765	MURS frequency accuracy	PASS	--
FCC Part 95.2771	MURS emission types	PASS	--
FCC Part 95.2775	MURS audio filter	PASS	--

NOTE: (1) "N/A" denotes test is not applicable in this Test Report.

(2) All tests are according to TIA 603-E.



1.1 TEST FACTORY

SHENZHEN STS TEST SERVICES CO., LTD

Add. : A 1/F, Building B, Zhuoke Science Park, No.190 Chongqing Road, HepingShequ, Fuyong Sub-District, Bao'an District, Shenzhen, Guang Dong, China

FCC test Firm Registration Number: 625569

IC test Firm Registration Number: 12108A

A2LA Certificate No.: 4338.01

1.2 MEASUREMENT UNCERTAINTY

The reported uncertainty of measurement $y \pm U$, where expanded uncertainty U is based on a standard uncertainty multiplied by a coverage factor of $k=2$, providing a level of confidence of approximately **95** %.

No.	Item	Uncertainty
1	RF output power, conducted	$\pm 0.87\text{Db}$
2	Unwanted Emissions, conducted	$\pm 2.895\text{Db}$
3	All emissions, radiated 9K-30MHz	$\pm 3.80\text{Db}$
4	All emissions, radiated 30M-1GHz	$\pm 4.09\text{Db}$
5	All emissions, radiated 1G-6GHz	$\pm 4.92\text{Db}$
6	All emissions, radiated >6G	$\pm 5.49\text{Db}$
7	Conducted Emission (9KHz-30MHz)	$\pm 2.73\text{Db}$



2. GENERAL INFORMATION

2.1 GENERAL DESCRIPTION OF THE EUT

Product Name	Two way radio	
Brand Name	BTECH	
Model Name	MURS-V2	
Series Model	N/A	
Model Difference	N/A	
Operation Frequency Range:	151.820MHz-154.600MHz Please refer to the note 3	
Antenna Type	Dipole	
Antenna Gain	1.8dBi	
Modulation Type	MURS	F3E
Emission types	MURS	16K2F3E
Adapter	Input:100-240V~ 50/60Hz 0.25A Output: DC 10V 0.5A	
Charger	Input: DC 10V 0.5A Output: DC 8.4V 0.5A	
Battery	Rated Voltage: 7.4V Charge Limit Voltage:8.4V Capacity: 1800mAh	
Hardware version number	220428	
Software version number	V22.8.23	
Connecting I/O Port(s)	Please refer to the note 1	

Note:

1. For a more detailed features description, please refer to the manufacturer's specifications or the User Manual.

2. The antenna information refer the manufacturer provide report, applicable only to the tested sample identified in the report. Due to the incorrect antenna information, a series of problems such as the accuracy of the test results will be borne by the customer.

3. Channel List

Channel	Frequency(MHz)	Channel	Frequency(MHz)	Channel	Frequency(MHz)
1	151.82	3	151.94	5	154.60
2	151.88	4	154.57	/	/

Test channel:

Channel	Frequency(MHz)	Low Power	High Power	Narrowband	Wideband
2	151.88	Support	Support	Support	Not Support
5	154.60	Support	Support	Support	Support



2.2 DESCRIPTION OF THE TEST MODES

To investigate the maximum EMI emission characteristics generated from EUT, the test system was pre-scanning tested based on the consideration of following EUT operation mode or test configuration mode which possibly have effect on EMI emission level. Each of these EUT operation mode(s) or test configuration mode(s) mentioned above was evaluated respectively.

Pretest Mode	Description
Mode 1	MURS CH2 Low Power TX Mode
Mode 2	MURS CH2 High Power TX Mode
Mode 3	MURS CH5 Low Power TX Mode
Mode 4	MURS CH5 High Power TX Mode

For Radiated Emission/Conducted Emission	
Final Test Mode	Description
Mode 1	MURS CH2 Low Power TX Mode
Mode 2	MURS CH2 High Power TX Mode
Mode 3	MURS CH5 Low Power TX Mode
Mode 4	MURS CH5 High Power TX Mode

Note: Wideband and Narrowband all has been tested, the worst case is Wideband, only shown the worst case in this report.

2.3 BLOCK DIAGRAM SHOWING THE CONFIGURATION OF SYSTEM TESTED

Radiated Spurious Emission Test

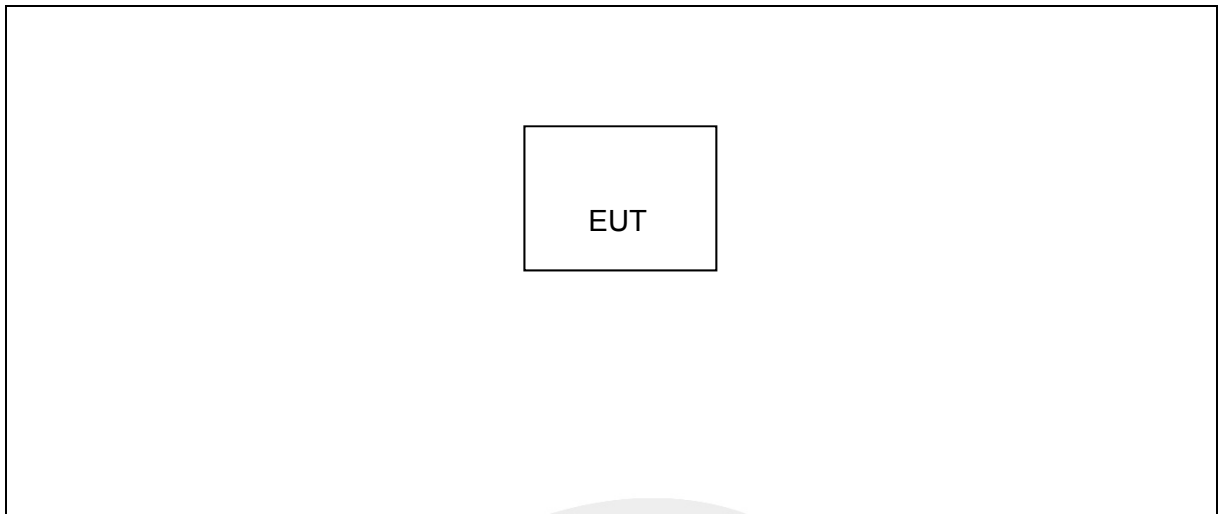

Conducted Emission Test

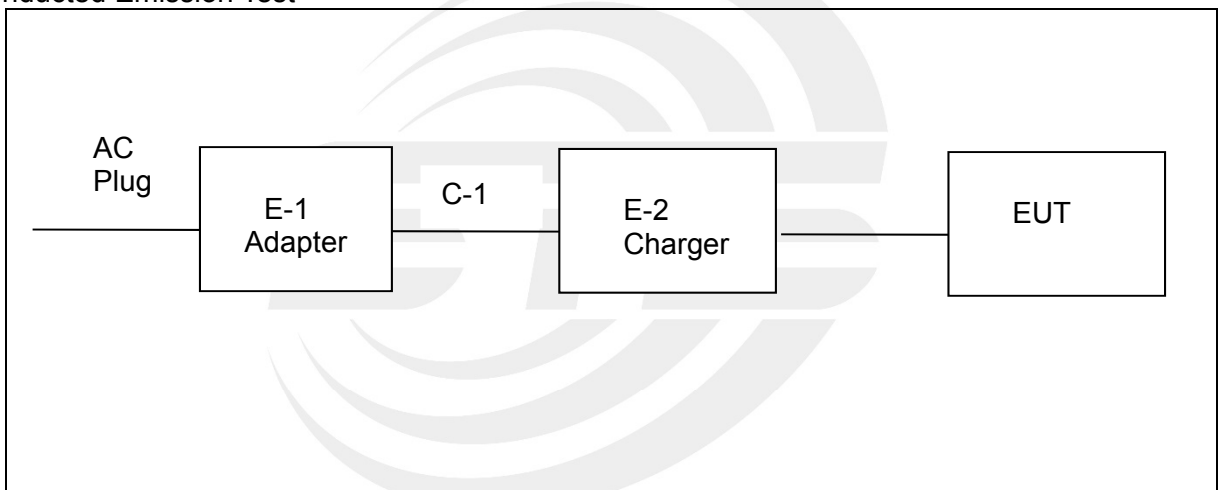



2.4 DESCRIPTION OF NECESSARY ACCESSORIES AND SUPPORT UNITS

The EUT has been tested as an independent unit together with other necessary accessories or support units. The following support units or accessories were used to form a representative test configuration during the tests.

Necessary accessories

Item	Equipment	Mfr/Brand	Model/Type No.	Length	Note
E-1	Adapter	BTECH	480-10050-E.S	N/A	N/A
E-2	Charger	BTECH	CH-8	N/A	N/A
C-1	USB Cable	N/A	N/A	110cm	NO

Support units

Item	Equipment	Mfr/Brand	Model/Type No.	Length	Note
N/A	N/A	N/A	N/A	N/A	N/A

Note:

(1) For detachable type I/O cable should be specified the length in cm in 『Length』 column.



2.5 EQUIPMENTS LIST

RF Radiation Test Equipment					
Kind of Equipment	Manufacturer	Type No.	Serial No.	Last Calibration	Calibrated Until
Temperature & Humidity	SW-108	SuWei	N/A	2022.03.02	2023.03.01
Wireless Communications Test Set	R&S	CMW 500	117239	2022.03.01	2023.02.28
Pre-Amplifier(0.1M-3GHz)	EM	EM330	060665	2022.07.04	2023.07.03
Pre-Amplifier (1G-18GHz)	SKET	LNPA-01018G-45	SK2018080901	2022.09.29	2023.09.28
Positioning Controller	MF	MF-7802	MF-780208587	N/A	N/A
Signal Analyzer	R&S	FSV 40-N	101823	2022.09.29	2023.09.28
Switch Control Box	N/A	N/A	N/A	N/A	N/A
Filter Box	BALUN Technology	SU319E	BL-SZ1530051	N/A	N/A
Video Controller	SKET	FCS C-3	N/A	N/A	N/A
Bilog Antenna	TESEQ	CBL6111D	34678	2022.09.30	2024.09.29
Horn Antenna	SCHWARZBECK	BBHA 9120D	02014	2021.10.11	2023.10.10
Antenna Mast	MF	MFA-440H	N/A	N/A	N/A
Turn Table	MF	N/A	N/A	N/A	N/A
AC Power Source	APC	KDF-11010G	F214050035	N/A	N/A
DC Power Supply	Zhaoxin	RXN 605D	20R605D11010081	N/A	N/A
Test SW	EMC Test Software	15.2.0.339			
RF Connected Test Equipment					
Kind of Equipment	Manufacturer	Type No.	Serial No.	Last Calibration	Calibrated Until
Temperature & Humidity	SW-108	SuWei	N/A	2022.03.02	2023.03.01
Universal Radio communication tester	R&S	CMU200	111058	2022.09.28	2023.09.27
Signal Generator	Agilent	N5182A	MY46240556	2022.09.28	2023.09.27
Signal Analyzer	Agilent	N9020A	MY52440124	2022.03.01	2023.02.28
Intercom comprehensive tester	HP	8920A	348A05658	2022.03.01	2023.02.28
Temperature & Humidity Test Chamber	Safety test	AG80L	171200018	2022.03.01	2023.02.28



Programmable Power Supply	Agilent	E3642A	MY40002025	2022.09.29	2023.09.28
Attenuator	HP	8494B	DC-18G	2022.03.02	2023.03.01
AC Power Source	APC	KDF-11010G	F214050035	N/A	N/A





3. FIELD STRENGTHS AND RADIATED SPURIOUS EMISSION

3.1 RADIATED EMISSION LIMITS

a) For transmitting equipment in the MURS shall comply with the following table:

Channel center frequencies (MHz)	Paragraphs
151.820, 151.880 and 151.940	(1), (2).
154.570 & 154.600, with audio filter	(3), (4), (7).
154.570 & 154.600, without audio filter	(5), (6), (7).

- (1) Each MURS transmitter type that transmits F3E or G3E emissions on 154.570 MHz or 154.600 MHz and incorporates an audio filter satisfying the requirements of § 95.2775 in its design may comply with the less stringent unwanted emissions attenuation requirements set forth in paragraphs (b)(3), (4), and (7) of this section.
 - (2) Each MURS transmitter type that transmits on 154.570 MHz or 154.600 MHz, but does not incorporate an audio filter satisfying the requirements of § 95.2775 in its design, must comply with the unwanted emissions attenuation requirements set forth in paragraphs (b)(5) through (7) of this section.
- b) The power of unwanted emissions must be attenuated below the transmitter output power in Watts (P) by at least:
- (1) $7.27(f_d - 2.88 \text{ kHz})$ dB on any frequency removed from the channel center frequency by a displacement frequency (f_d in kHz) that is more than 5.625 kHz, but not more than 12.5 kHz.
 - (2) $50 + 10 \log(P)$ dB or 70 dB, whichever is the lesser attenuation, on any frequency removed from the channel center frequency by more than 12.5 kHz.
 - (3) 25 dB on any frequency removed from the channel center frequency by more than 10 kHz, but not more than 20 kHz.
 - (4) 35 dB on any frequency removed from the channel center frequency by more than 20 kHz, but not more than 50 kHz.
 - (5) $83 \log(f_d \div 5)$ dB on any frequency removed from the center of the authorized bandwidth by a displacement frequency (f_d in kHz) that is more than 5 kHz, but not more than 10 kHz.
 - (6) $29 \log(f_d^2 \div 11)$ dB or 50 dB, whichever is the lesser attenuation on any frequency removed from the channel center frequency by a displacement frequency (f_d in kHz) that is more than 10 kHz, but not more than 50 kHz.
 - (7) $43 + 10 \log(P)$ dB on any frequency removed from the channel center frequency by more than 50 kHz.

$43 + 10 \log(P_{\text{watts}})$

Calculation: Limit (dBm) = EL - 43 - 10 log₁₀ (TP)

Notes: EL is the emission level of the Output Power expressed in dBm,

In this application, the EL is P (dBm).

Limit (dBm) = P (dBm) - 43 - 10 log (Pwatts) = -13 dBm

Frequencies (MHz)	Field Strength (micorvolts/meter)	Measurement Distance (meters)
0.009~0.490	2400/F(KHz)	300
0.490~1.705	24000/F(KHz)	30
1.705~30.0	30	30
30~88	100	3
88~216	150	3
216~960	200	3
Above 960	500	3



Spectrum Parameter	Setting
Detector	Peak
Attenuation	Auto
Start Frequency	30 MHz
Stop Frequency	10th carrier harmonic

3.2 TEST PROCEDURE

1. EUT was placed on a 1.5 meter high non-conductive stand at a 3 meter test distance from the receive antenna. A receiving antenna was placed on the antenna mast 3 meters from the EUT for emission measurements. The height of receiving antenna is 1.0 m. Detected emissions were maximized at each frequency by rotating the EUT through 360° and adjusting the receiving antenna polarization. The radiated emission measurements of all transmit frequencies in three channels were measured with peak detector.
2. A log-periodic antenna or double-ridged waveguide horn antenna shall be substituted in place of the EUT. The log-periodic antenna will be driven by a signal generator and the level will be adjusted till the same power value on the spectrum analyzer or receiver. The level of the spurious emissions can be calculated through the level of the signal generator, cable loss, the gain of the substitution antenna and the reading of the spectrum analyzer or receiver.
3. The EUT is then put into continuously transmitting mode at its maximum power level during the test. Set Test Receiver or Spectrum RBW=1MHz, VBW=3MHz for above 1GHz and BW=100kHz, VBW=300kHz for 30MHz to 1GHz, And the maximum value of the receiver should be recorded as (Pr).
4. The EUT shall be replaced by a substitution antenna. In the chamber, an substitution antenna for the frequency band of interest is placed at the reference point of the chamber. An RF Signal source for the frequency band of interest is connected to the substitution antenna with a cable that has been constructed to not interfere with the radiation pattern of the antenna. A power (P_{Mea}) is applied to the input of the substitution antenna, and adjust the level of the signal generator output until the value of the receiver reach the previously recorded (Pr). The power of signal source (P_{Mea}) is recorded. The test should be performed by rotating the test item and adjusting the receiving antenna polarization.
5. A amplifier should be connected to the Signal Source output port. And the cable should be connect between the Amplifier and the Substitution Antenna. The cable loss (P_{cl}), the Substitution Antenna Gain (G_a) and the Amplifier Gain (P_{Ag}) should be recorded after test. The measurement results are obtained as described below:
$$\text{Power(EIRP)} = P_{Mea} - P_{Ag} - P_{cl} + G_a$$

We used signal generator which signal level can up to 33dBm, so we not used power Amplifier for substitution test; The measurement results are amend as described below:
$$\text{Power(EIRP)} = P_{Mea} - P_{cl} + G_a$$
6. This value is EIRP since the measurement is calibrated using an antenna of known gain (2.15 dBi) and known input power
7. ERP can be calculated from EIRP by subtracting the gain of the dipole, $ERP = EIRP - 2.15\text{dBi}$

3.3 TEST SETUP

For radiated test from 30MHz to 1GHz

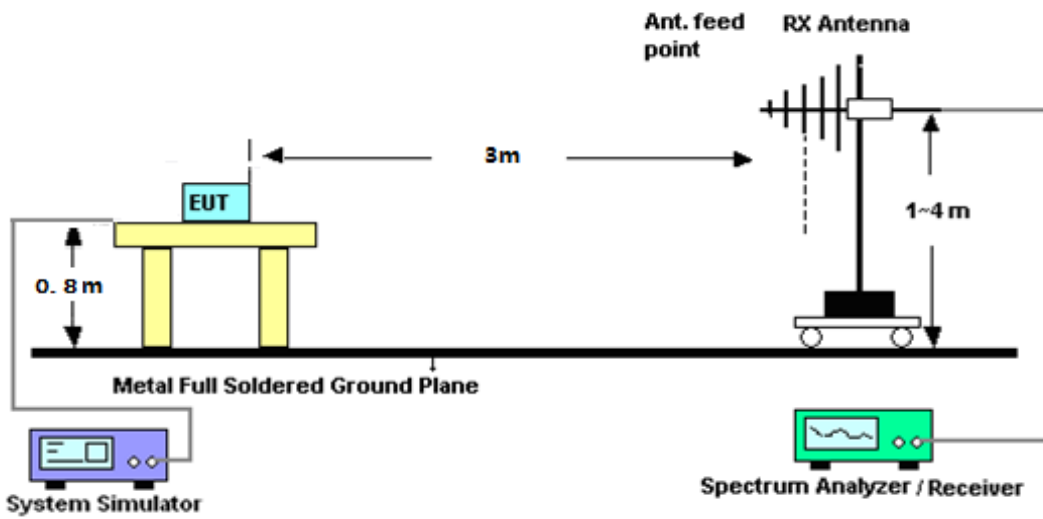

For radiated test from above 1GHz

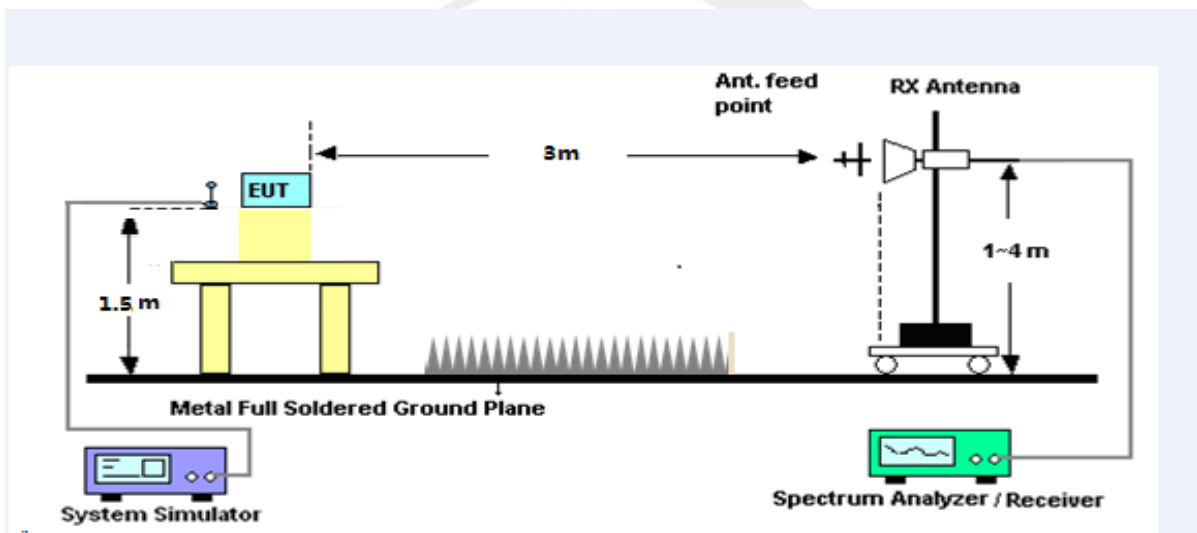

3.4 EUT OPERATING CONDITIONS

The EUT was configured for testing in a typical fashion (as a customer would normally use it). The EUT has been programmed to continuously transmit during test. This operating condition was tested and used to collect the included data.



3.5 TEST RESULT

Temperature:	23.4 °C	Relative Humidity:	60%
Test Mode:	Mode 1	Phase :	Horizontal

RSE_FCC Test Case_FCC 95 30MHz-5GHz-Limit-H

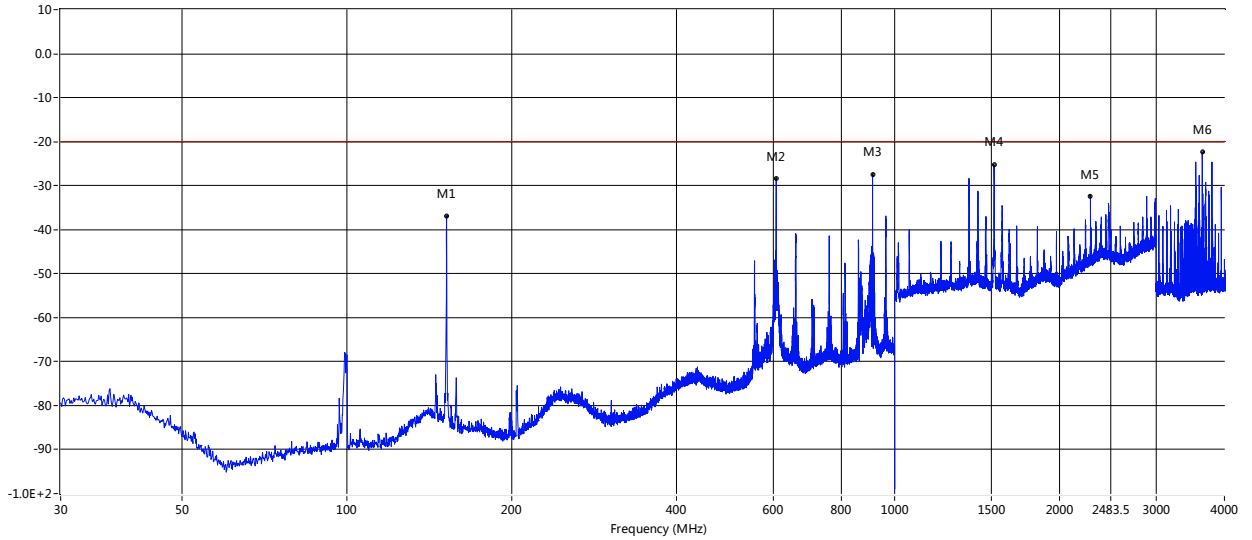

Frequency (MHz)	Result (dBm)	Factor (dB)	PK Limit (dBm)	Over Limit (dB)	Table (o)	ANT	EUT	Verdict
151.977	-36.92	-6.72	-20.0	-16.92	315.40	Horizontal	Vertical	Pass
607.514	-28.35	6.49	-20.0	-8.35	31.00	Horizontal	Vertical	Pass
911.366	-27.44	9.26	-20.0	-7.44	22.00	Horizontal	Vertical	Pass
1519.000	-25.32	12.69	-20.0	-5.32	195.90	Horizontal	Vertical	Pass
2278.500	-32.42	17.57	-20.0	-12.42	175.20	Horizontal	Vertical	Pass
3645.250	-22.43	3.32	-20.0	-2.43	360.00	Horizontal	Vertical	Pass



Temperature:	23.4 °C	Relative Humidity:	60%
Test Mode:	Mode 1	Phase:	Vertical

RSE_FCC Test Case_FCC 95 30MHz-5GHz-Limit-V

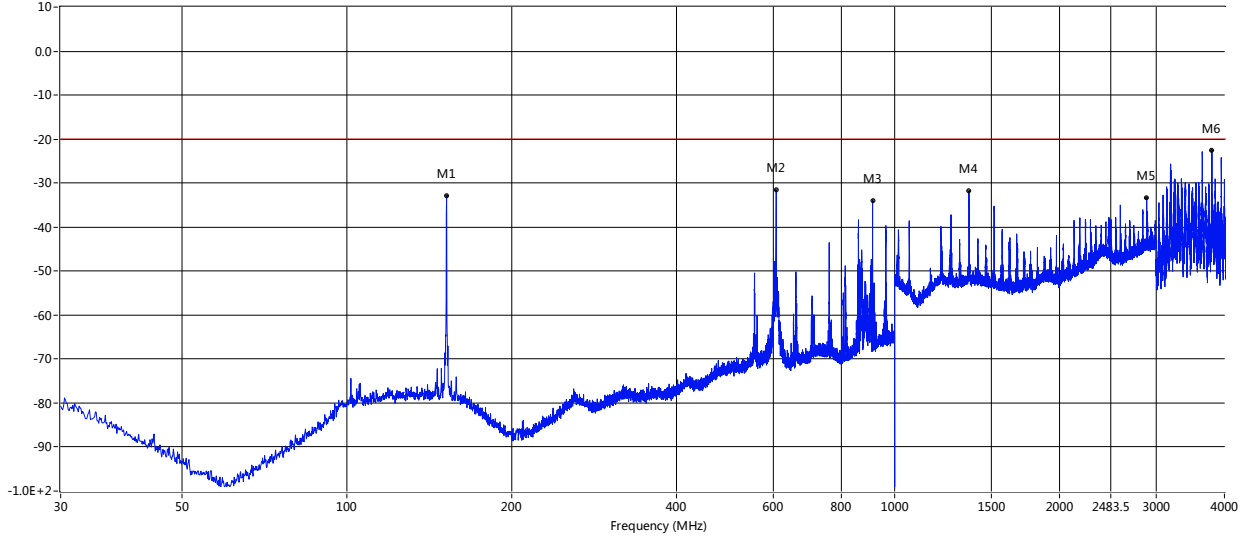

Frequency (MHz)	Result (dBm)	Factor (dB)	PK Limit (dBm)	Over Limit (dB)	Table (o)	ANT	EUT	Verdict
151.977	-32.83	-1.68	-20.0	-12.83	0.80	Vertical	Vertical	Pass
607.514	-31.61	4.97	-20.0	-11.61	116.70	Vertical	Vertical	Pass
911.366	-33.95	8.62	-20.0	-13.95	63.00	Vertical	Vertical	Pass
1367.000	-31.85	13.55	-20.0	-11.85	169.90	Vertical	Vertical	Pass
2886.000	-33.22	20.18	-20.0	-13.22	233.30	Vertical	Vertical	Pass
3797.000	-22.59	2.85	-20.0	-2.59	180.10	Vertical	Vertical	Pass



Temperature:	23.4 °C	Relative Humidity:	60%
Test Mode:	Mode 2	Phase :	Horizontal

RSE_FCC Test Case_FCC 95 30MHz-5GHz-Limit-H

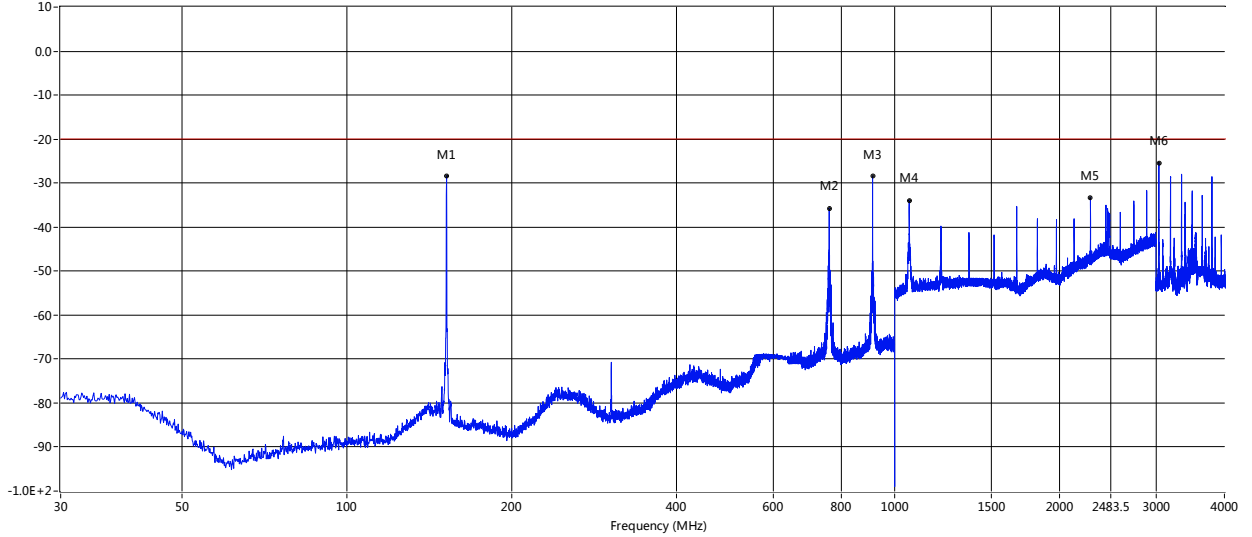

Frequency (MHz)	Result (dBm)	Factor (dB)	PK Limit (dBm)	Over Limit (dB)	Table (o)	ANT	EUT	Verdict
151.977	-28.30	-6.72	-20.0	-8.30	319.40	Horizontal	Vertical	Pass
759.440	-35.74	7.26	-20.0	-15.74	319.40	Horizontal	Vertical	Pass
911.366	-28.44	9.26	-20.0	-8.44	20.50	Horizontal	Vertical	Pass
1063.250	-33.91	11.40	-20.0	-13.91	111.90	Horizontal	Vertical	Pass
2278.500	-33.29	17.57	-20.0	-13.29	171.80	Horizontal	Vertical	Pass
3037.750	-25.37	2.66	-20.0	-5.37	240.70	Horizontal	Vertical	Pass



Temperature:	23.4 °C	Relative Humidity:	60%
Test Mode:	Mode 2	Phase:	Vertical

RSE_FCC Test Case_FCC 95 30MHz-5GHz-Limit-V

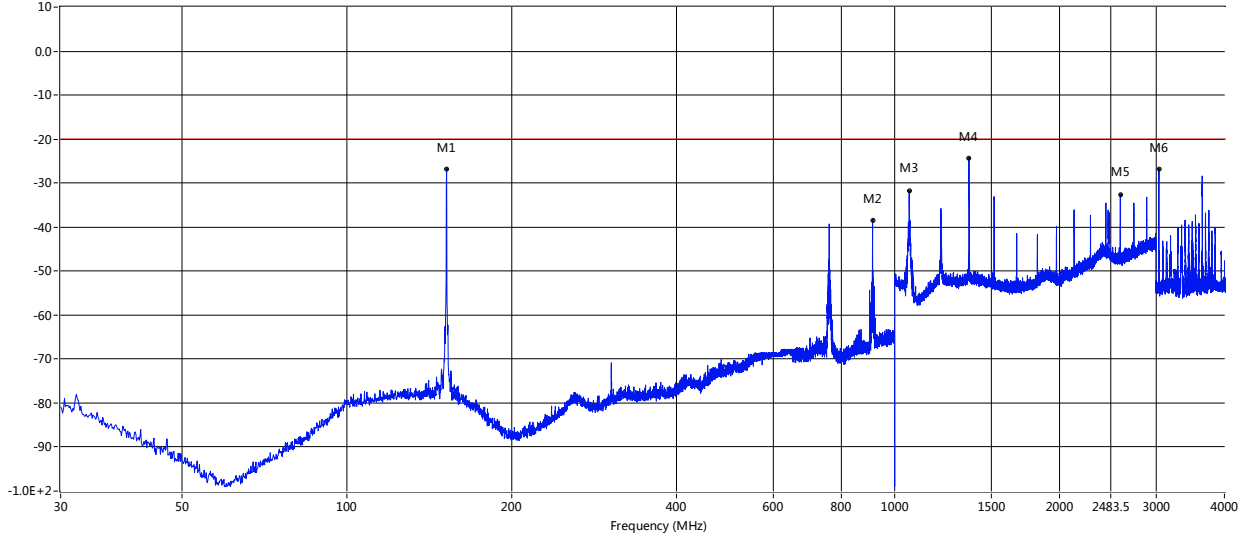

Frequency (MHz)	Result (dBm)	Factor (dB)	PK Limit (dBm)	Over Limit (dB)	Table (o)	ANT	EUT	Verdict
151.977	-26.86	-1.68	-20.0	-6.86	1.00	Vertical	Vertical	Pass
911.366	-38.40	8.62	-20.0	-18.40	4.50	Vertical	Vertical	Pass
1063.000	-33.54	10.32	-20.0	-13.54	173.00	Vertical	Vertical	Pass
1367.000	-24.39	13.55	-20.0	-4.39	184.80	Vertical	Vertical	Pass
2582.000	-32.58	17.68	-20.0	-12.58	178.90	Vertical	Vertical	Pass
3037.750	-26.79	1.91	-20.0	-6.79	170.90	Vertical	Vertical	Pass



Temperature:	23.4 °C	Relative Humidity:	60%
Test Mode:	Mode 3	Phase :	Horizontal

RSE_FCC Test Case_FCC 95 30MHz-5GHz-H

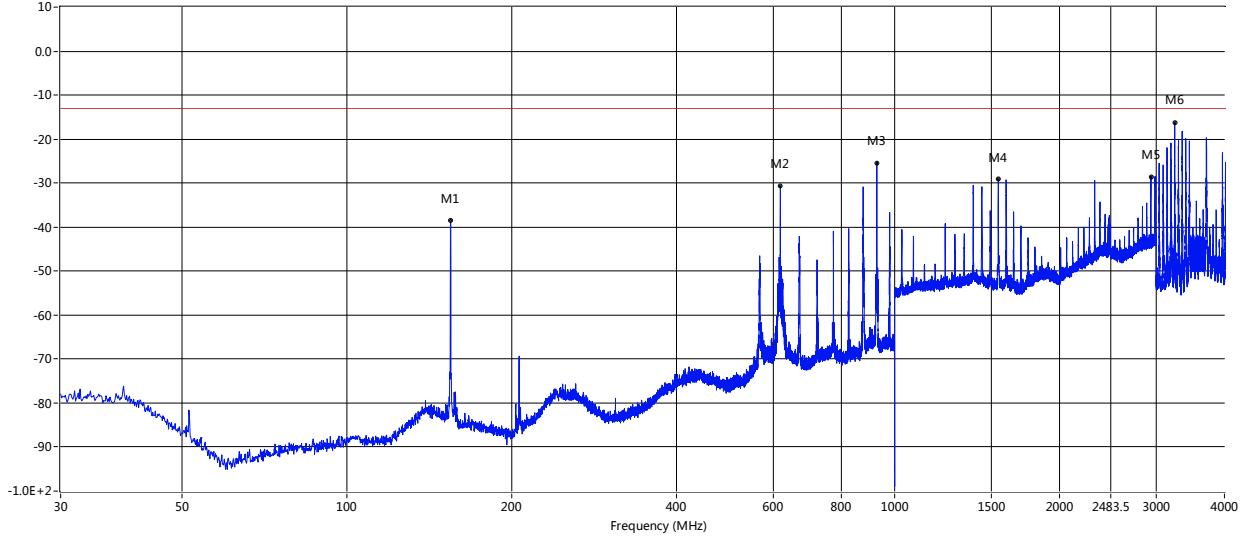

Frequency (MHz)	Result (dBm)	Factor (dB)	PK Limit (dBm)	Over Limit (dB)	Table (o)	ANT	EUT	Verdict
154.645	-38.57	-7.24	-13.0	-25.57	321.30	Horizontal	Vertical	Pass
618.426	-30.71	7.18	-13.0	-17.71	222.50	Horizontal	Vertical	Pass
927.735	-25.36	9.05	-13.0	-12.36	357.10	Horizontal	Vertical	Pass
1546.000	-29.04	12.73	-13.0	-16.04	284.60	Horizontal	Vertical	Pass
2938.000	-28.51	20.90	-13.0	-15.51	215.10	Horizontal	Vertical	Pass
3246.750	-16.16	2.81	-13.0	-3.16	186.10	Horizontal	Vertical	Pass



Temperature:	23.4 °C	Relative Humidity:	60%
Test Mode:	Mode 3	Phase:	Vertical

RSE_FCC Test Case_FCC 95 30MHz-5GHz-V

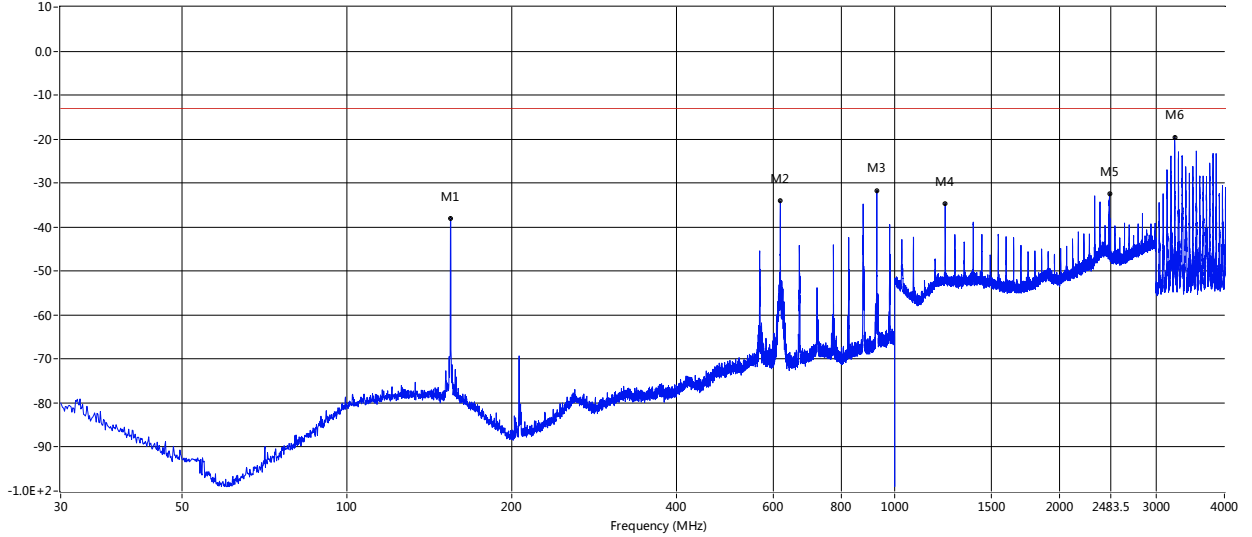

Frequency (MHz)	Result (dBm)	Factor (dB)	PK Limit (dBm)	Over Limit (dB)	Table (o)	ANT	EUT	Verdict
154.645	-38.08	-1.80	-13.0	-25.08	0.90	Vertical	Vertical	Pass
618.426	-34.09	5.35	-13.0	-21.09	0.20	Vertical	Vertical	Pass
927.735	-31.70	9.42	-13.0	-18.70	262.00	Vertical	Vertical	Pass
1237.000	-34.67	13.51	-13.0	-21.67	241.60	Vertical	Vertical	Pass
2467.500	-32.48	18.61	-13.0	-19.48	23.90	Vertical	Vertical	Pass
3246.750	-19.56	2.01	-13.0	-6.56	204.60	Vertical	Vertical	Pass



Temperature:	23.4 °C	Relative Humidity:	60%
Test Mode:	Mode 4	Phase :	Horizontal

RSE_FCC Test Case_FCC 95 30MHz-5GHz-H

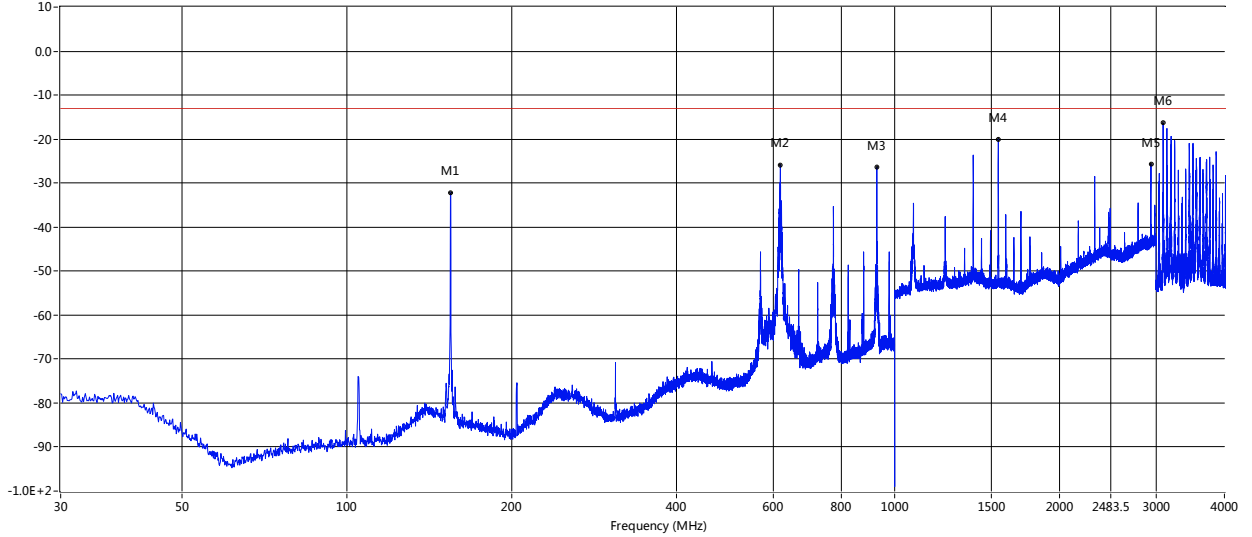

Frequency (MHz)	Result (dBm)	Factor (dB)	PK Limit (dBm)	Over Limit (dB)	Table (o)	ANT	EUT	Verdict
154.524	-32.27	-7.21	-13.0	-19.27	325.30	Horizontal	Vertical	Pass
618.426	-25.84	7.18	-13.0	-12.84	139.70	Horizontal	Vertical	Pass
927.735	-26.39	9.05	-13.0	-13.39	41.50	Horizontal	Vertical	Pass
1546.000	-20.05	12.73	-13.0	-7.05	274.00	Horizontal	Vertical	Pass
2937.750	-25.69	20.90	-13.0	-12.69	235.10	Horizontal	Vertical	Pass
3092.000	-16.32	2.83	-13.0	-3.32	213.20	Horizontal	Vertical	Pass



Temperature:	23.4 °C	Relative Humidity:	60%
Test Mode:	Mode 4	Phase:	Vertical

RSE_FCC Test Case_FCC 95 30MHz-5GHz-V

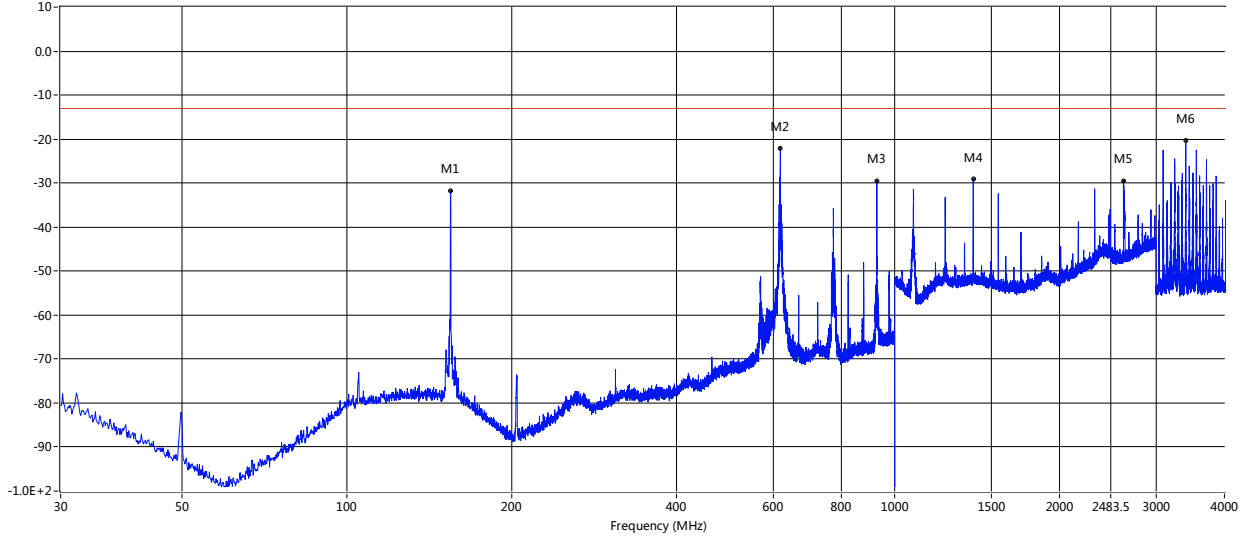

Frequency (MHz)	Result (dBm)	Factor (dB)	PK Limit (dBm)	Over Limit (dB)	Table (o)	ANT	EUT	Verdict
154.645	-31.81	-1.80	-13.0	-18.81	0.30	Vertical	Vertical	Pass
618.426	-22.20	5.35	-13.0	-9.20	0.00	Vertical	Vertical	Pass
927.735	-29.54	9.42	-13.0	-16.54	145.00	Vertical	Vertical	Pass
1391.500	-29.08	13.76	-13.0	-16.08	167.80	Vertical	Vertical	Pass
2618.250	-29.54	17.83	-13.0	-16.54	337.10	Vertical	Vertical	Pass
3401.500	-20.37	1.58	-13.0	-7.37	202.40	Vertical	Vertical	Pass



4. SPURIOUS EMISSION ON ANTENNA PORT

4.1 LIMIT

a) For transmitting equipment in the MURS shall comply with the following table:

Channel center frequencies (MHz)	Paragraphs
151.820, 151.880 and 151.940	(1), (2).
154.570 & 154.600, with audio filter	(3), (4), (7).
154.570 & 154.600, without audio filter	(5), (6), (7).

- (1) Each MURS transmitter type that transmits F3E or G3E emissions on 154.570 MHz or 154.600 MHz and incorporates an audio filter satisfying the requirements of § 95.2775 in its design may comply with the less stringent unwanted emissions attenuation requirements set forth in paragraphs (b)(3), (4), and (7) of this section.
- (2) Each MURS transmitter type that transmits on 154.570 MHz or 154.600 MHz, but does not incorporate an audio filter satisfying the requirements of § 95.2775 in its design, must comply with the unwanted emissions attenuation requirements set forth in paragraphs (b)(5) through (7) of this section.
- b) The power of unwanted emissions must be attenuated below the transmitter output power in Watts (P) by at least:
 - (1) $7.27(f_d - 2.88 \text{ kHz})$ dB on any frequency removed from the channel center frequency by a displacement frequency (f_d in kHz) that is more than 5.625 kHz, but not more than 12.5 kHz.
 - (2) $50 + 10 \log(P)$ dB or 70 dB, whichever is the lesser attenuation, on any frequency removed from the channel center frequency by more than 12.5 kHz.
 - (3) 25 dB on any frequency removed from the channel center frequency by more than 10 kHz, but not more than 20 kHz.
 - (4) 35 dB on any frequency removed from the channel center frequency by more than 20 kHz, but not more than 50 kHz.
 - (5) $83 \log(f_d \div 5)$ dB on any frequency removed from the center of the authorized bandwidth by a displacement frequency (f_d in kHz) that is more than 5 kHz, but not more than 10 kHz.
 - (6) $29 \log(f_d^2 \div 11)$ dB or 50 dB, whichever is the lesser attenuation on any frequency removed from the channel center frequency by a displacement frequency (f_d in kHz) that is more than 10 kHz, but not more than 50 kHz.
 - (7) $43 + 10 \log(P)$ dB on any frequency removed from the channel center frequency by more than 50 kHz.

$43 + 10 \log(P_{\text{watts}})$

Calculation: Limit (dBm) = EL - 43 - 10 log₁₀ (TP)

Notes: EL is the emission level of the Output Power expressed in dBm,

In this application, the EL is P (dBm).

Limit (dBm) = P (dBm) - 43 - 10 log (Pwatts) = -13 dBm

4.2 TEST PROCEDURE

1. The EUT was connected to the spectrum analyzer through sufficient attenuation.
2. Sufficient scans were taken to show any out of band emission up to 10th. Harmonic for the lower and the highest frequency range.
3. Set EUT as digital data mode.
4. Set RBW 30kHz, VBW 100 kHz in the frequency band 30MHz to 1GHz, while set RBW=1MHz. VBW=3MHz from the 1GHz to 10th Harmonic.



4.3 TEST SETUP



4.4 EUT OPERATION CONDITIONS

TX mode.

4.5 TEST RESULT

Mode 1

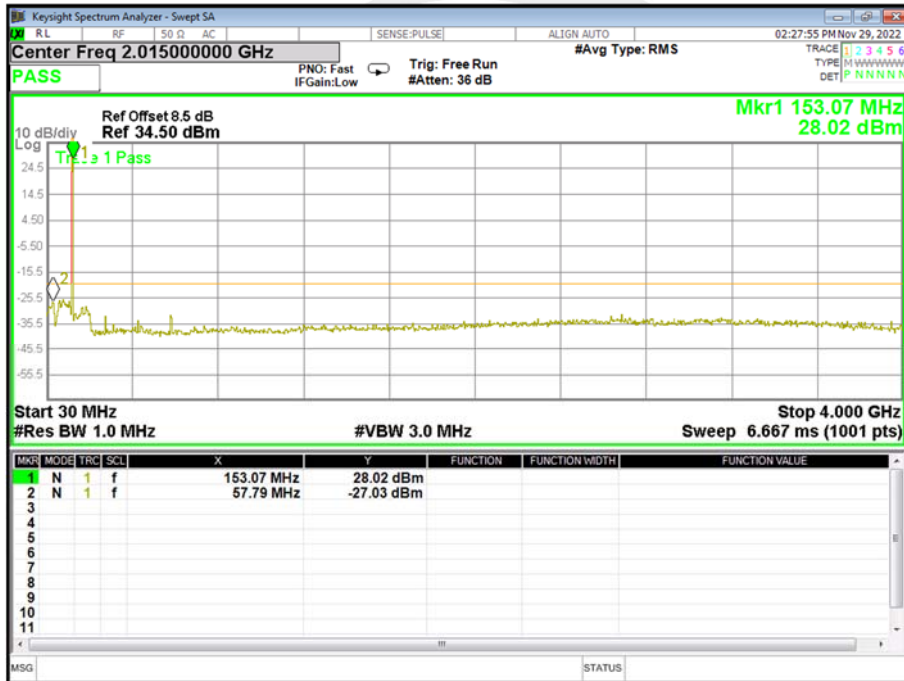



Mode 2

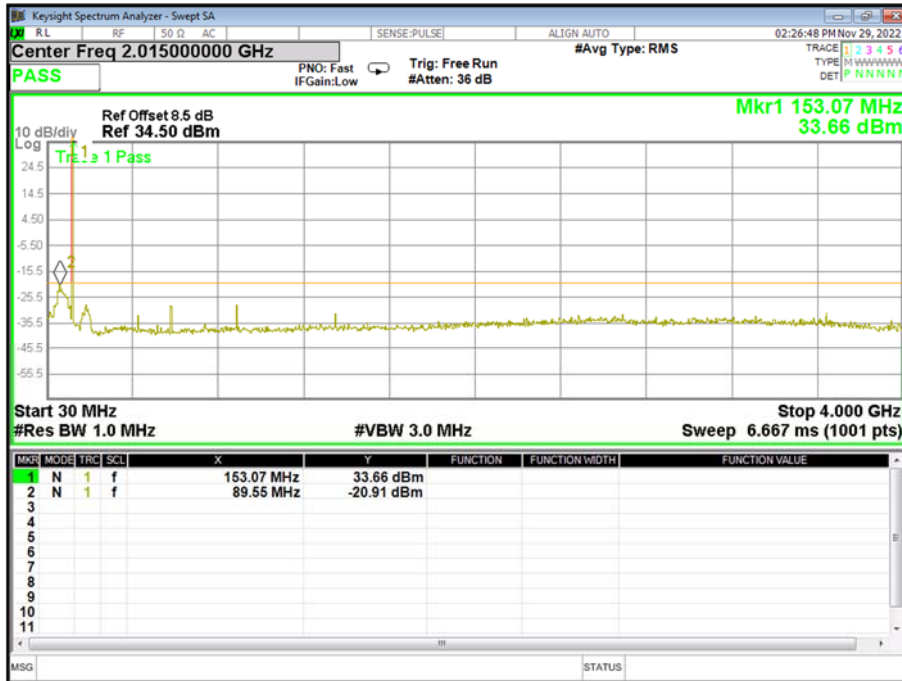

Mode 3

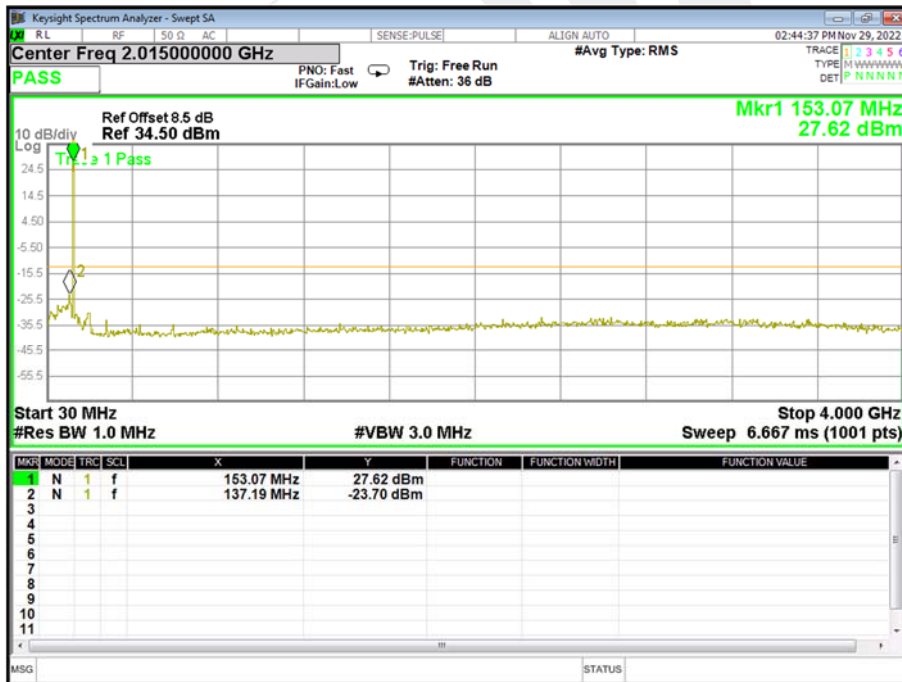



Mode 4

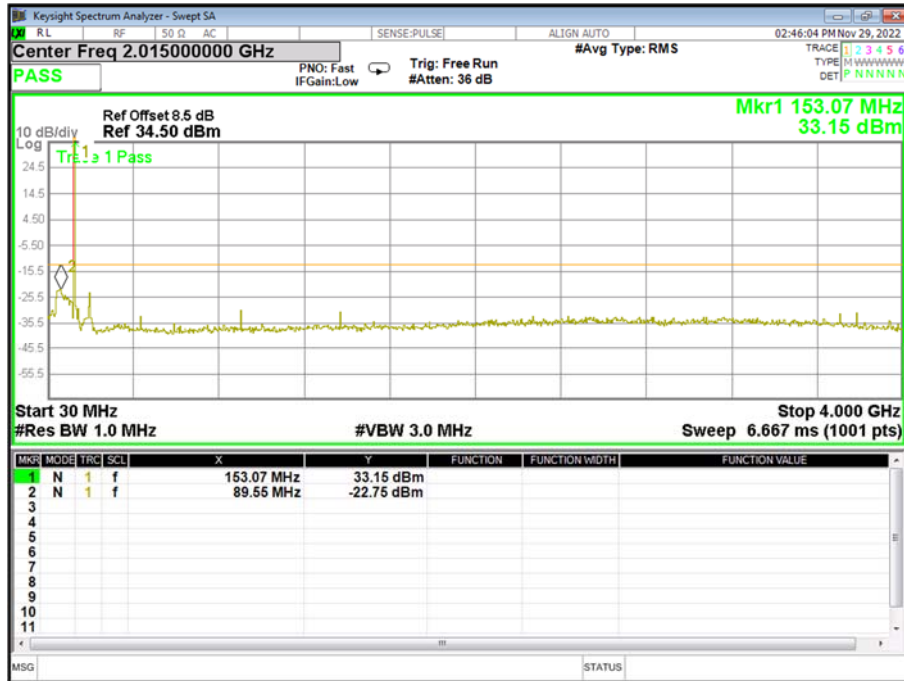



5. TRANSMITTER OUTPUT POWER

5.1 LIMIT

Each MURS transmitter type must be designed such that the transmitter power output does not exceed 2 Watts under normal operating conditions.

5.2 TEST PROCEDURE

Measurements shall be made to establish the radio frequency power delivered by the transmitter the standard output termination. The power output shall be monitored and recorded and no adjustment shall be made to the transmitter after the test has begun, except as noted below: If the power output is adjustable, measurements shall be made for the highest and lowest power levels. The EUT connect to the Spectrum Analyzer through 30 dB attenuator.

5.3 TEST SETUP

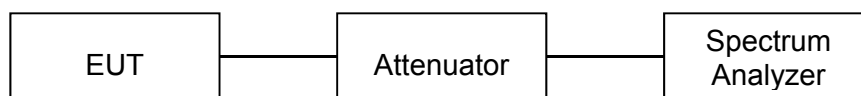

5.4 TEST RESULTS

Low Power:

Operation Mode	Test Frequency(MHz)	Bandwidth	Test Results (dBm)	Test Results (W)	Limit (W)	Result
MURS	151.88	Narrow band	26.93	0.49	2	Pass
	154.60	Narrow band	27.73	0.59	2	Pass
	154.60	Wideband	27.77	0.60	2	Pass

High Power:

Operation Mode	Test Frequency(MHz)	Bandwidth	Test Results (dBm)	Test Results (W)	Limit (W)	Result
MURS	151.88	Narrow band	32.25	1.68	2	Pass
	154.60	Narrow band	31.95	1.57	2	Pass
	154.60	Wideband	32.17	1.65	2	Pass

6. BANDWIDTH TEST

6.1 LIMIT

Each MURS transmitter type must be designed to meet the emission bandwidth limitations in this section.

- (a) The occupied bandwidth of emissions transmitted on the center frequencies 151.820 MHz, 151.880 MHz, and 151.940 MHz must not exceed 11.25 kHz.
- (b) The occupied bandwidth of emissions transmitted on the center frequencies 154.570 MHz and 154.600 MHz must not exceed 20.0 kHz.
- (c) The occupied bandwidth of type A3E emissions must not exceed 8.0 kHz.

6.2 TEST PROCEDURE

1. The EUT was connected to the spectrum analyzer through sufficient attenuation.
2. Set EUT as digital data mode.
3. Set SPA Center Frequency=fundamental frequency, RBW=100Hz, VBW=1KHz, span =15KHz.
4. Set SPA Max hold. Mark peak, Set 99% Occupied Bandwidth.

6.3 TEST SETUP

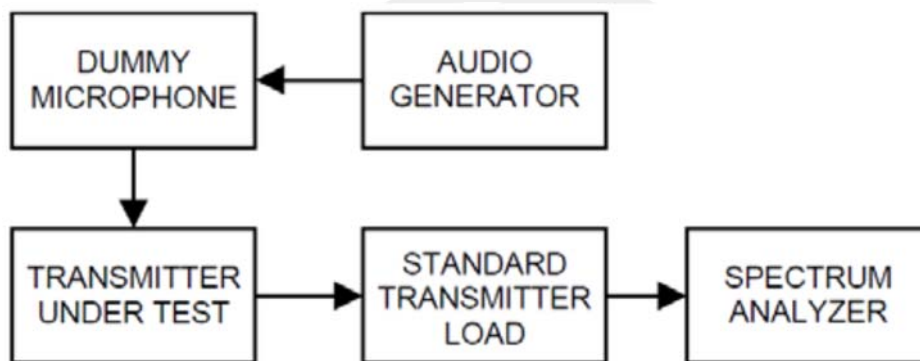

6.4 EUT OPERATION CONDITIONS

TX mode.



6.5 TEST RESULTS

Low Power

Operation Mode	Test Frequency(MHz)	Bandwidth	99% Occupied Bandwidth(KHz)	Limits (KHz)	Result
MURS	151.88	Narrow band	9.522	11.25	Pass
	154.60	Narrow band	9.378	20	Pass
	154.60	Wideband	16.198	20	Pass

High Power

Operation Mode	Test Frequency(MHz)	Bandwidth	99% Occupied Bandwidth(KHz)	Limits (KHz)	Result
MURS	151.88	Narrow band	9.463	11.25	Pass
	154.60	Narrow band	9.303	20	Pass
	154.60	Wideband	16.209	20	Pass

Narrow band:
CH2_Low Power

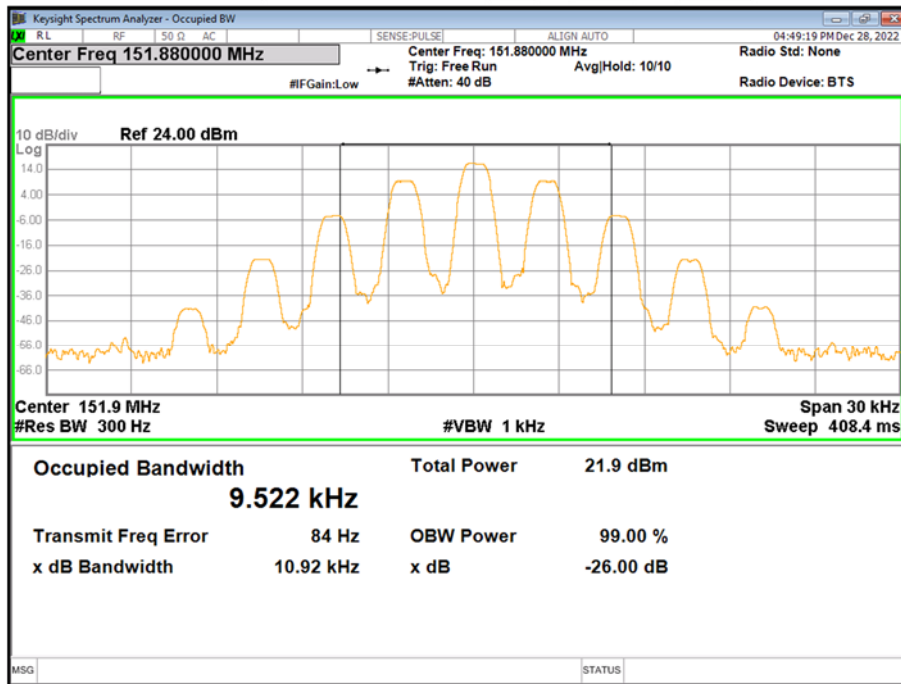



CH5_Low Power

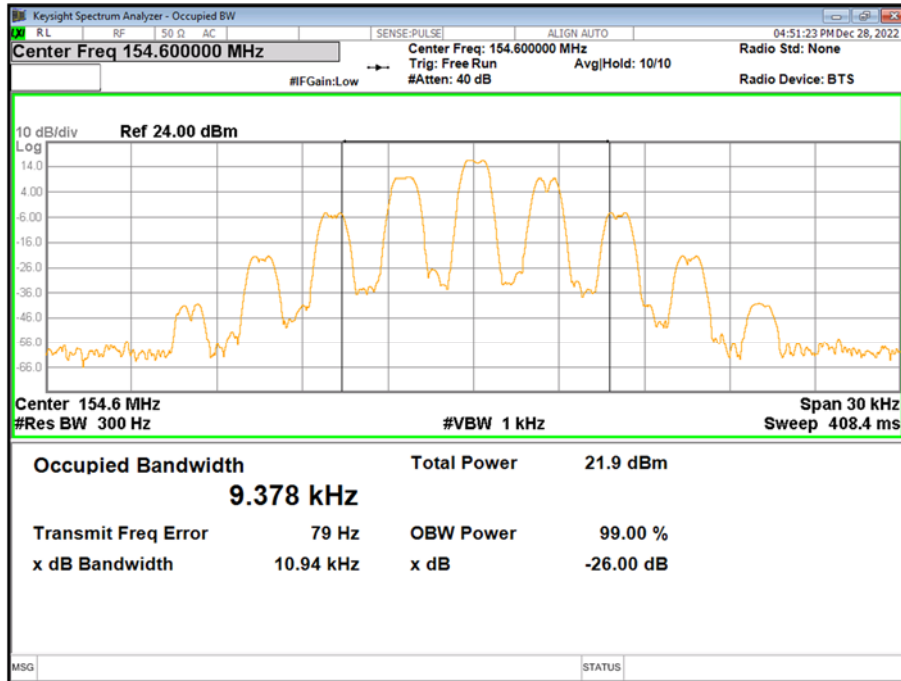

CH2_High Power

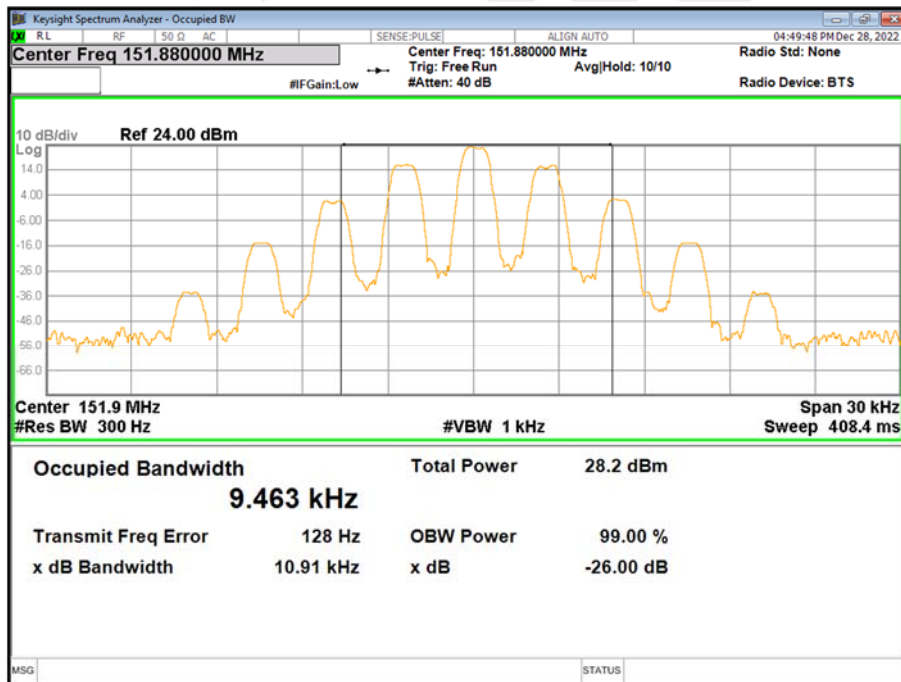



CH5_High Power

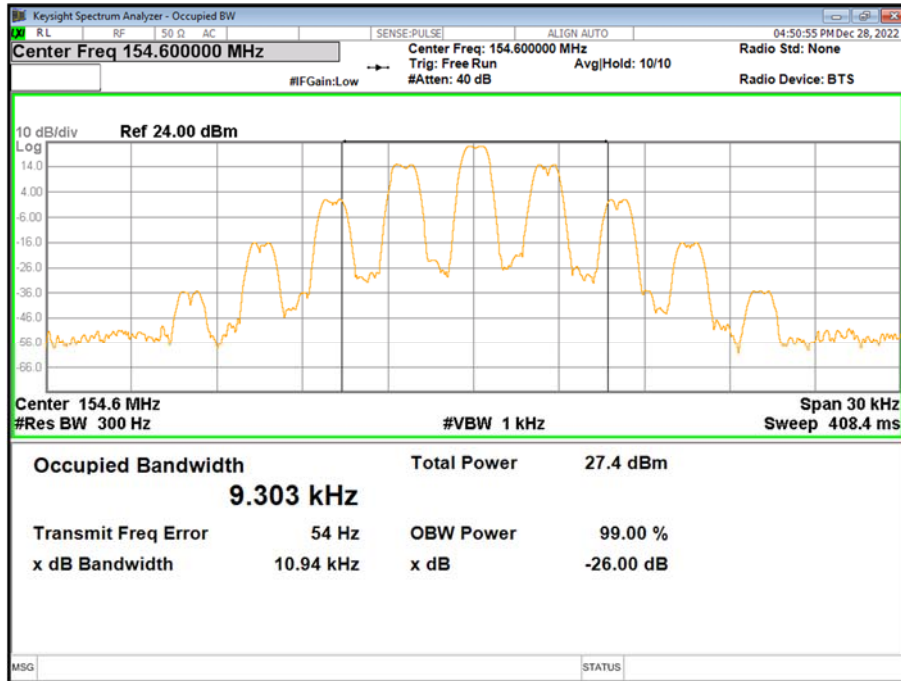

Wideband:

CH5_Low Power

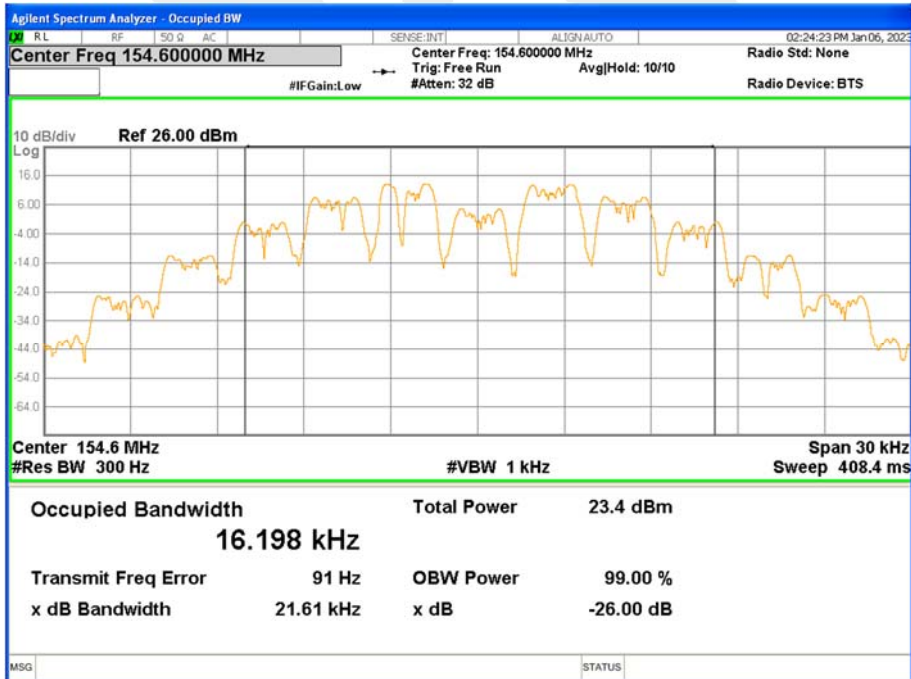



CH5_High Power

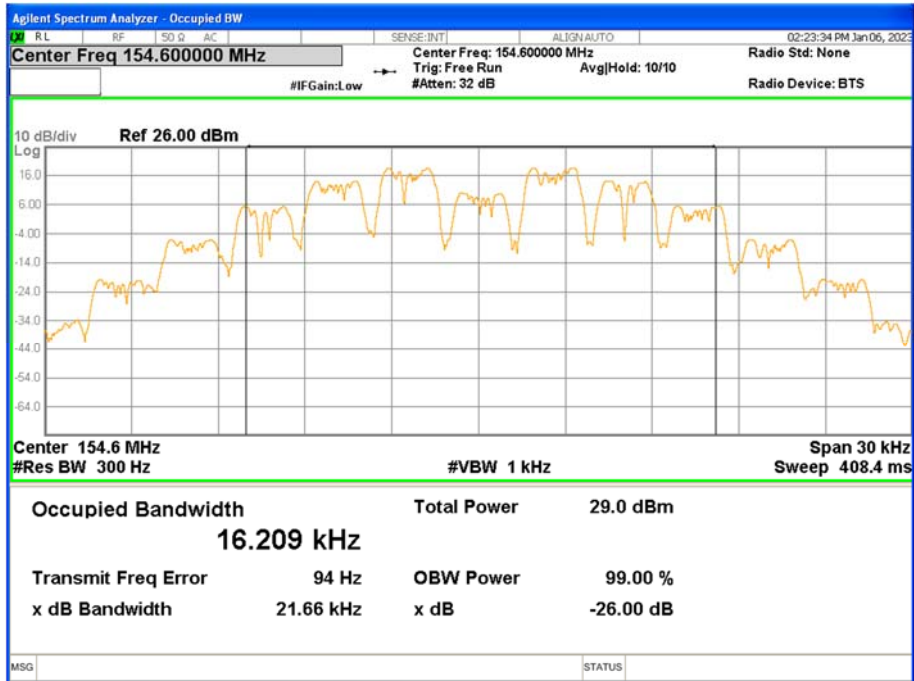



7. EMISSION MASK

7.1 LIMIT

a) For transmitting equipment in the MURS shall comply with the following table:

Channel center frequencies (MHz)	Paragraphs
151.820, 151.880 and 151.940	(1), (2).
154.570 & 154.600, with audio filter	(3), (4), (7).
154.570 & 154.600, without audio filter	(5), (6), (7).

- (1) Each MURS transmitter type that transmits F3E or G3E emissions on 154.570 MHz or 154.600 MHz and incorporates an audio filter satisfying the requirements of § 95.2775 in its design may comply with the less stringent unwanted emissions attenuation requirements set forth in paragraphs (b)(3), (4), and (7) of this section.
 - (2) Each MURS transmitter type that transmits on 154.570 MHz or 154.600 MHz, but does not incorporate an audio filter satisfying the requirements of § 95.2775 in its design, must comply with the unwanted emissions attenuation requirements set forth in paragraphs (b)(5) through (7) of this section.
- b) The power of unwanted emissions must be attenuated below the transmitter output power in Watts (P) by at least:
- (1) $7.27(f_d - 2.88 \text{ kHz})$ dB on any frequency removed from the channel center frequency by a displacement frequency (f_d in kHz) that is more than 5.625 kHz, but not more than 12.5 kHz.
 - (2) $50 + 10 \log(P)$ dB or 70 dB, whichever is the lesser attenuation, on any frequency removed from the channel center frequency by more than 12.5 kHz.
 - (3) 25 dB on any frequency removed from the channel center frequency by more than 10 kHz, but not more than 20 kHz.
 - (4) 35 dB on any frequency removed from the channel center frequency by more than 20 kHz, but not more than 50 kHz.
 - (5) $83 \log(f_d \div 5)$ dB on any frequency removed from the center of the authorized bandwidth by a displacement frequency (f_d in kHz) that is more than 5 kHz, but not more than 10 kHz.
 - (6) $29 \log(f_d^2 \div 11)$ dB or 50 dB, whichever is the lesser attenuation on any frequency removed from the channel center frequency by a displacement frequency (f_d in kHz) that is more than 10 kHz, but not more than 50 kHz.
 - (7) $43 + 10 \log(P)$ dB on any frequency removed from the channel center frequency by more than 50 kHz.

$43 + 10 \log(P_{\text{watts}})$

Calculation: Limit (dBm) = EL - 43 - 10 log₁₀ (TP)

Notes: EL is the emission level of the Output Power expressed in dBm,

In this application, the EL is P (dBm).

Limit (dBm) = P (dBm) - 43 - 10 log (Pwatts) = -13 dBm

7.2 TEST PROCEDURE

1. The EUT was connected to the spectrum analyzer through sufficient attenuation.
2. Set EUT as digital data mode.
3. Set SPA Center Frequency=fundamental frequency, RBW=300Hz, VBW=3KHz, span =120KHz.

7.3 TEST SETUP

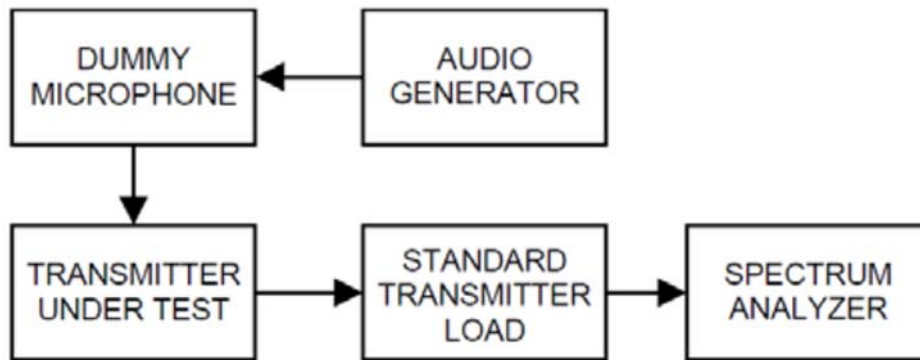

7.4 EUT OPERATION CONDITIONS

TX mode.





7.5 TEST RESULT

Narrow band:

Mode 1

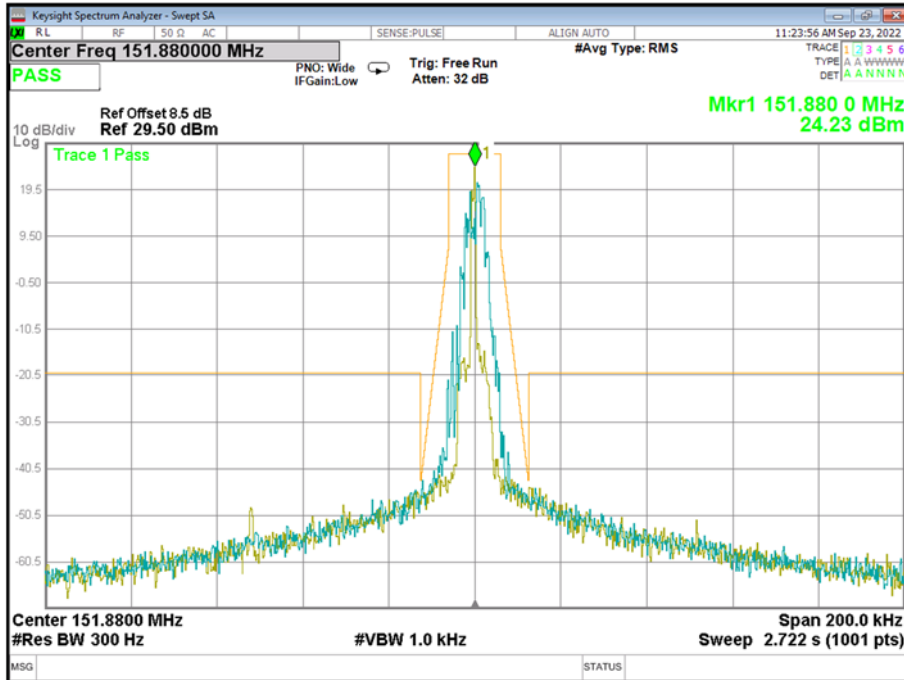

Mode 2

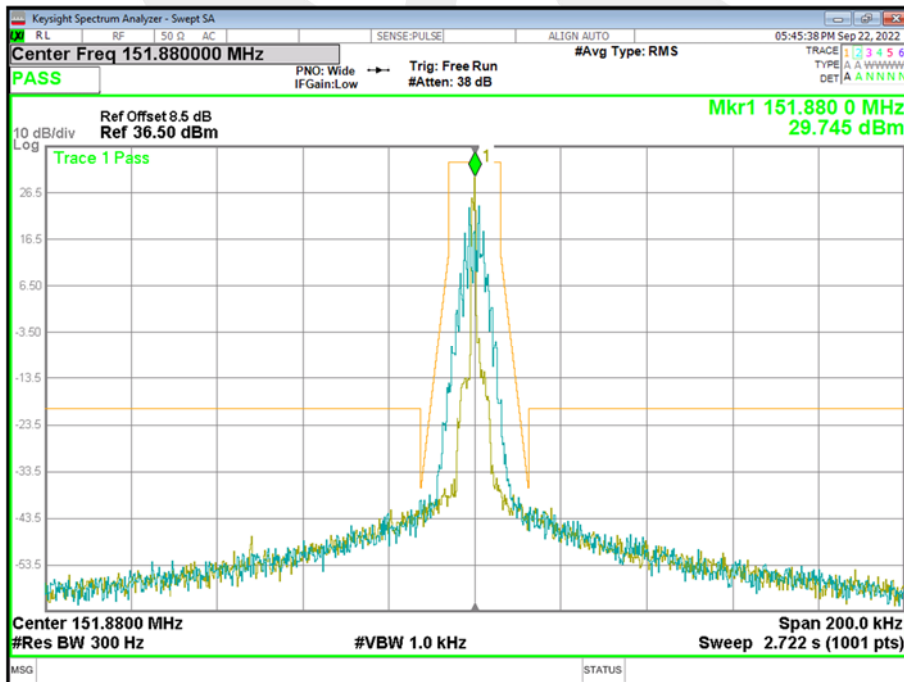



Mode 3

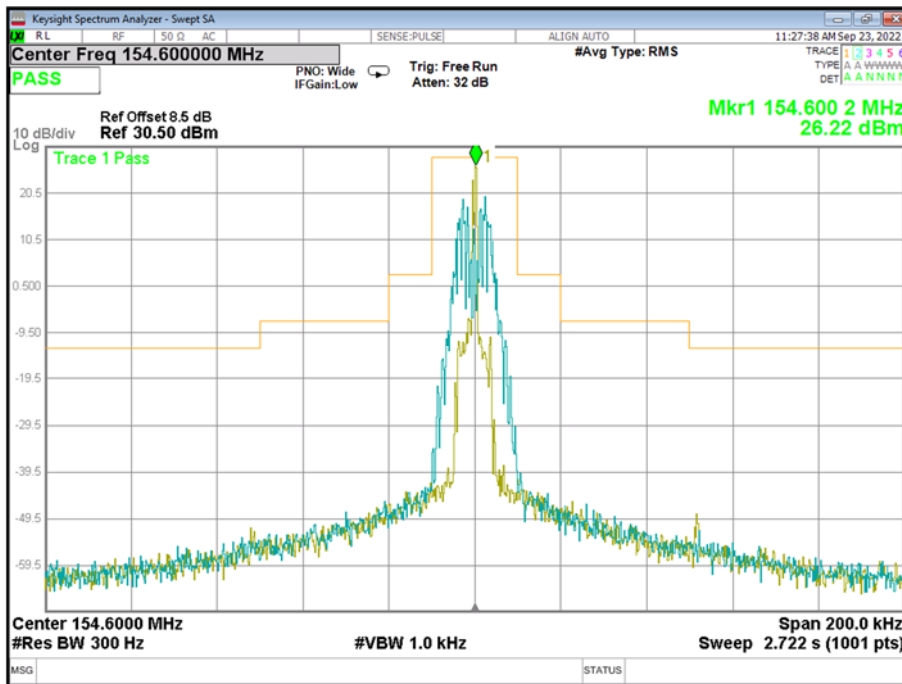

Mode 4

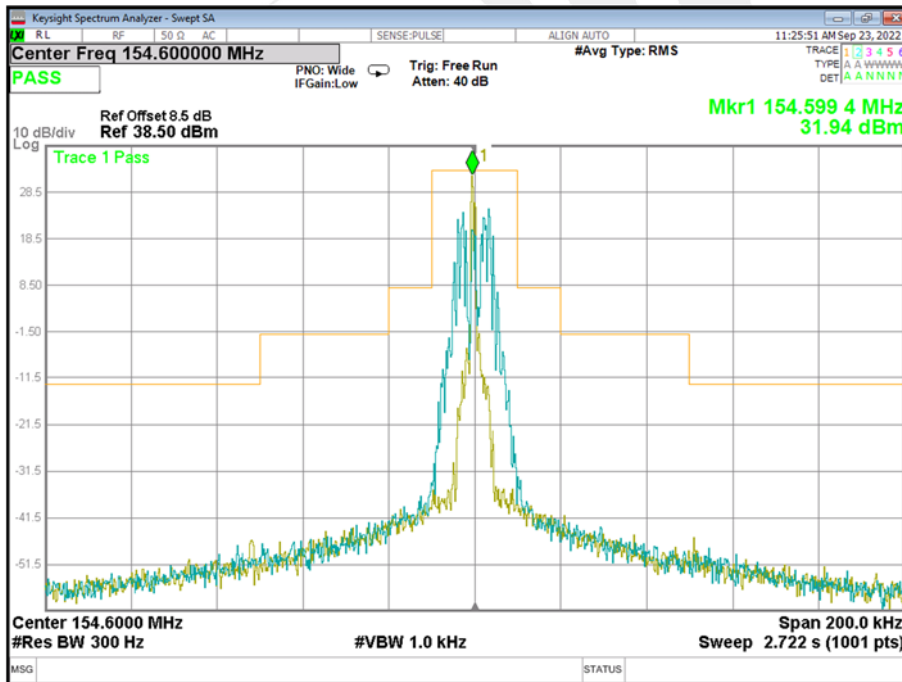



Wideband:

Mode 3

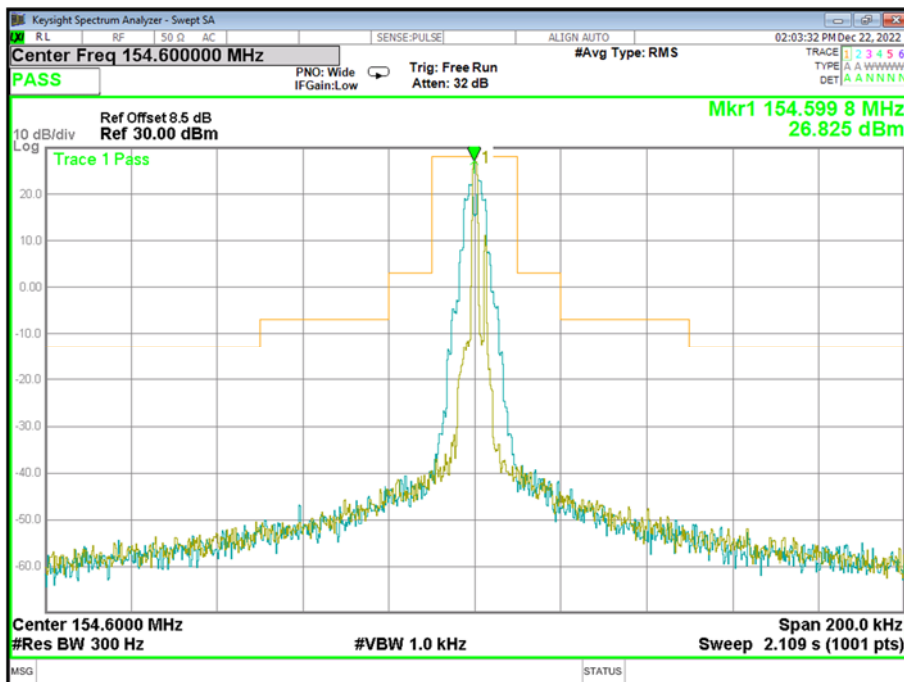

Mode 4

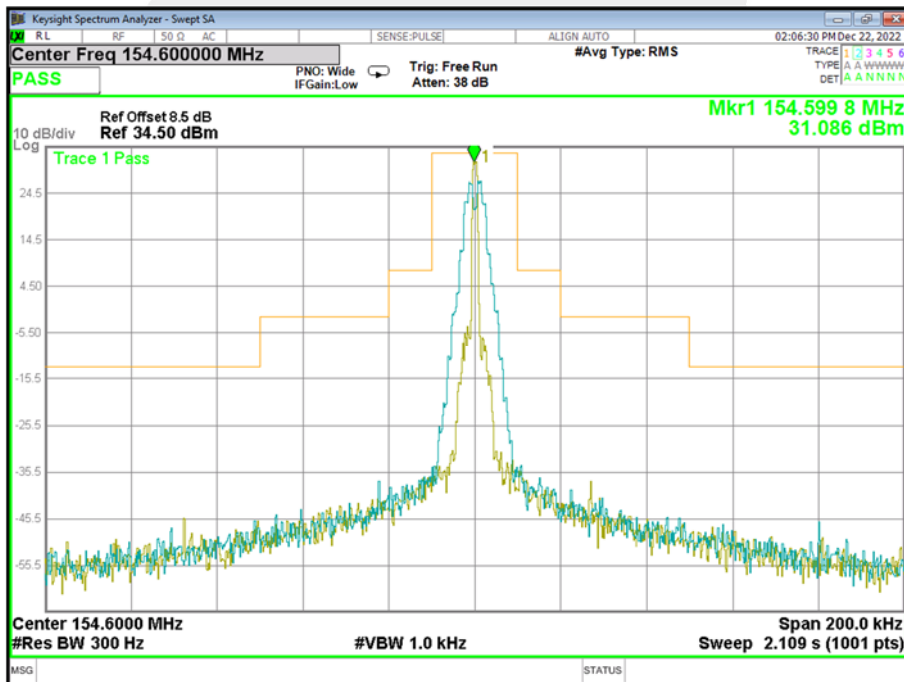

8. FREQUENCY STABILITY

8.1 LIMIT

(a) MURS transmitters that operate with an emission bandwidth of 6.25 kHz or less must be designed such that the carrier frequencies remain within ± 2.0 parts-per-million (ppm) of the channel center frequencies specified in § 95.2763 during normal operating conditions.

(b) MURS transmitters that operate with an emission bandwidth greater than 6.25 kHz must be designed such that the carrier frequencies remain within ± 5.0 ppm of the channel center frequencies specified in § 95.2763 during normal operating conditions.

8.2 TEST PROCEDURE

1. The frequency stability shall be measured with variation of ambient temperature from -30°C to $+50^{\circ}\text{C}$
2. For battery powered equipment, the frequency stability shall be measured with reducing primary supply voltage to the battery operating end point, which is specified by the manufacture.
3. Vary primary supply voltage from 6.29V to 8.51V.
4. The EUT was set in the climate chamber and connected to an external DC power supply. The RF output was directly connected to Spectrum Analyzer. The coupling loss of the additional cables was recorded and taken in account for all the measurements. After temperature stabilization (approx. 20 min for each stage), the frequency for the lower, the middle and the highest frequency range was recorded. For Frequency stability Vs. Voltage the EUT was connected to a DC power supply and the voltage was adjusted in the required ranges. The result was recorded

8.3 TEST SETUP

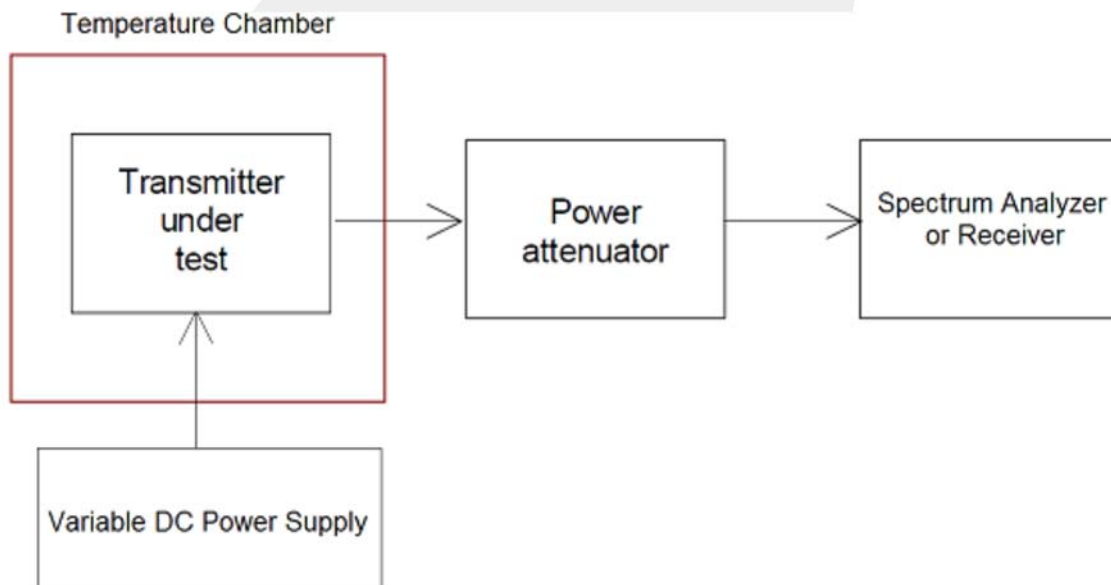

8.4 EUT OPERATION CONDITIONS

TX mode.



8.5 TEST RESULT

Note: All mode has been tested, only shown the worst case in this report.

MURS_(151.88MHz)						
Voltage	Temperature (°C)	Nominal Frequency (MHz)	Measured Frequency (MHz)	Frequency error (ppm)	Limit	Result
Normal Voltage	-30	151.880	151.8799	-0.6584	±5ppm	Pass
	-20	151.880	151.8795	-3.2921		
	-10	151.880	151.8800	0.0000		
	0	151.880	151.8799	-0.6584		
	10	151.880	151.8797	-1.9752		
	20	151.880	151.8797	-1.9752		
	30	151.880	151.8803	1.9752		
	40	151.880	151.8796	-2.6337		
Maximum Voltage	50	151.880	151.8802	1.3168		
	20	151.880	151.8802	1.3168		
BEP	20	151.880	151.8802	1.3168		

MURS_(154.60MHz)						
Voltage	Temperature (°C)	Nominal Frequency (MHz)	Measured Frequency (MHz)	Frequency error (ppm)	Limit	Result
Normal Voltage	-30	154.600	154.5999	-0.6468	±5ppm	Pass
	-20	154.600	154.5999	-0.6468		
	-10	154.600	154.6003	1.9405		
	0	154.600	154.6000	0.0000		
	10	154.600	154.6002	1.2937		
	20	154.600	154.6000	0.0000		
	30	154.600	154.5999	-0.6468		
	40	154.600	154.5999	-0.6468		
Maximum Voltage	50	154.600	154.6002	1.2937		
	20	154.600	154.6000	0.0000		
BEP	20	154.600	154.6003	1.9405		

9. MURS AUDIO FILTER

9.1 LIMIT

- (a) The audio filter must be between the modulation limiter and the modulated stage of the transmitter.
- (b) At any frequency (f in kHz) between 3 and 15 kHz, the filter must have an attenuation of at least $40 \log(f/3)$ dB more than the attenuation at 1 kHz. Above 15 kHz, it must have an attenuation of at least 28 dB more than the attenuation at 1 kHz.

9.2 TEST PROCEDURE

1. Configure the EUT as shown in figure
2. Apply a 1000 Hz tone from the audio signal generator and adjust the level per manufacturer's specifications. Record the dB level of the 1000 Hz tone as LEV_{REF} .
3. Set the audio signal generator to the desired test frequency between 3000 Hz and the upper low pass filter limit. Record the dB level at the test frequency as LEV_{FREQ}
4. Calculate the audio frequency response at the test frequency as:
low pass filter response = $LEV_{FREQ} - LEV_{REF}$

9.3 TEST SETUP

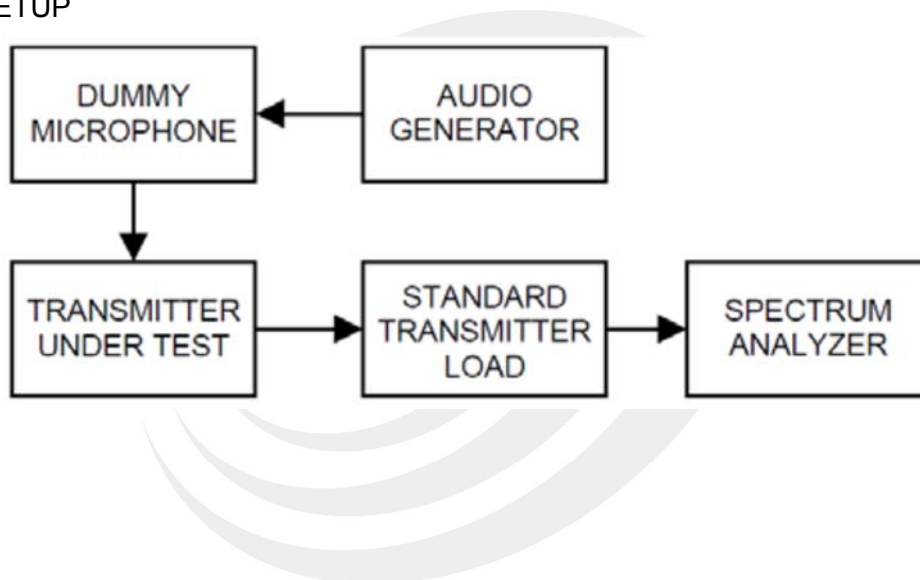



9.4 TEST RESULT

Note: All mode has been tested, only shown the worst case in this report.

MURS_(151.88MHz)			
Audio Frequency(KHz)	Limit	Response Attenuation(dB)	Result
3	0	-3.66	PASS
3.5	-2.68	-8.71	
4	-5	-12.35	
5	-8.87	-19.43	
7	-14.72	-28.85	
10	-20.92	-39.58	
15	-27.96	-54.73	
20	-28	-64.00	
30	-28	-63.96	
50	-28	-63.97	
70	-28	-64.09	

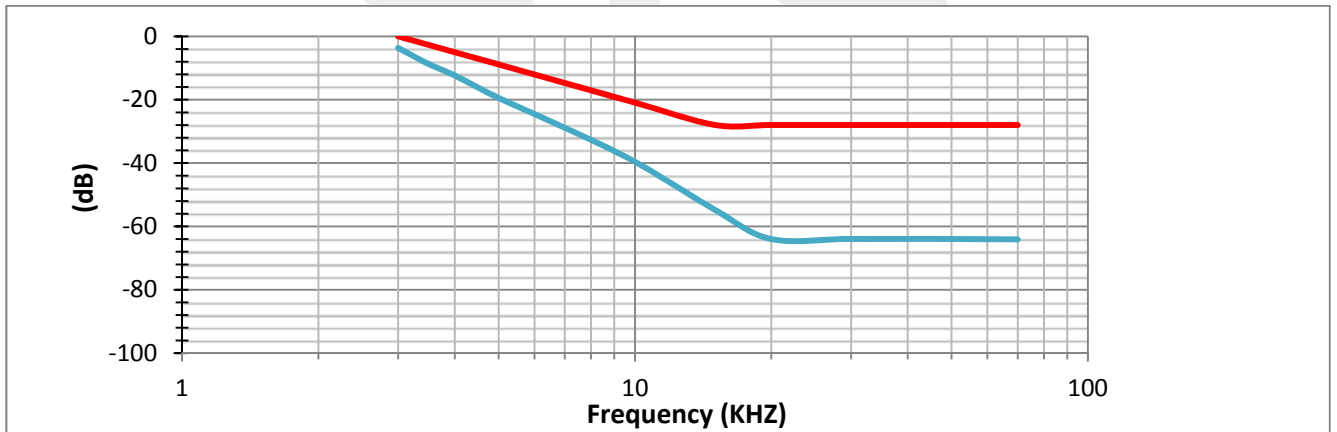



MURS_154.6MHz			
Audio Frequency(KHz)	Limit	Response Attenuation(dB)	Result
3	0	-3.61	PASS
3.5	-2.68	-8.62	
4	-5	-12.29	
5	-8.87	-19.64	
7	-14.72	-28.93	
10	-20.92	-39.72	
15	-27.96	-54.69	
20	-28	-64.06	
30	-28	-64.02	
50	-28	-64.00	
70	-28	-64.15	

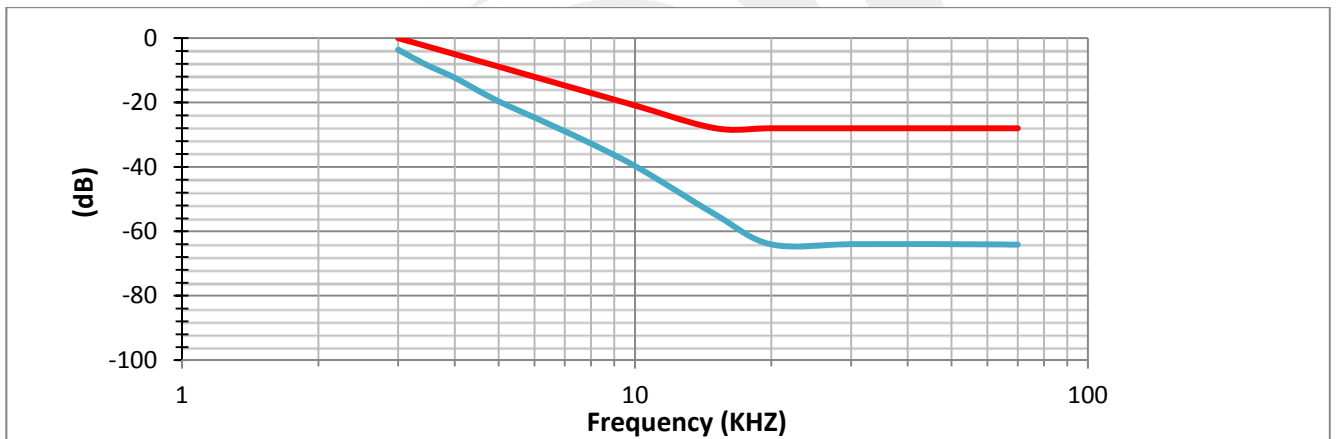



APPENDIX 1- PHOTOS OF TEST SETUP

Note: See test photos in setup photo document for the actual connections between Product and support equipment.

*****END OF THE REPORT*****

