

11N40_HCH_Graphs

Pref/11N40
/HCH

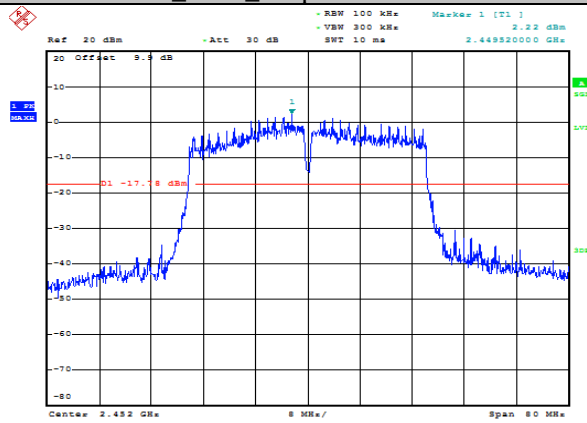

Date: 24.JAN.2017 17:06:54

Puw/11N40
/HCH

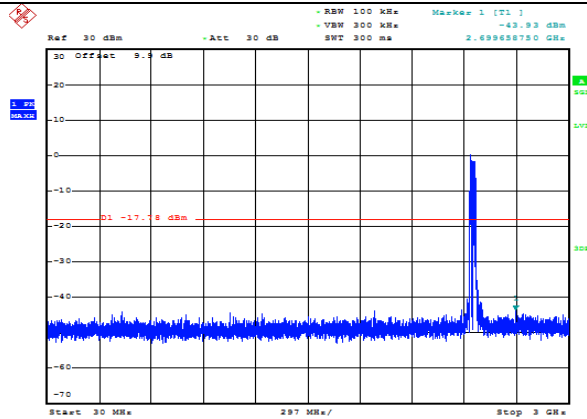

Date: 24.JAN.2017 17:07:01

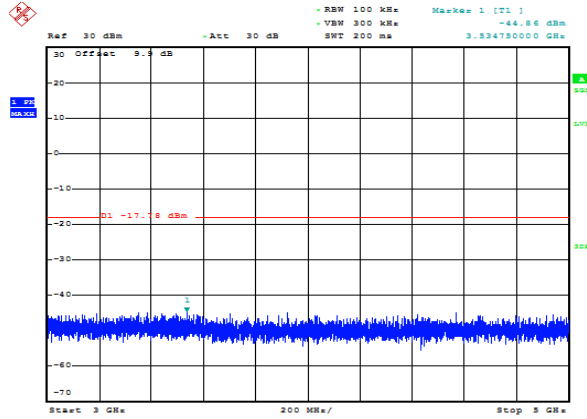

Date: 24.JAN.2017 17:07:08

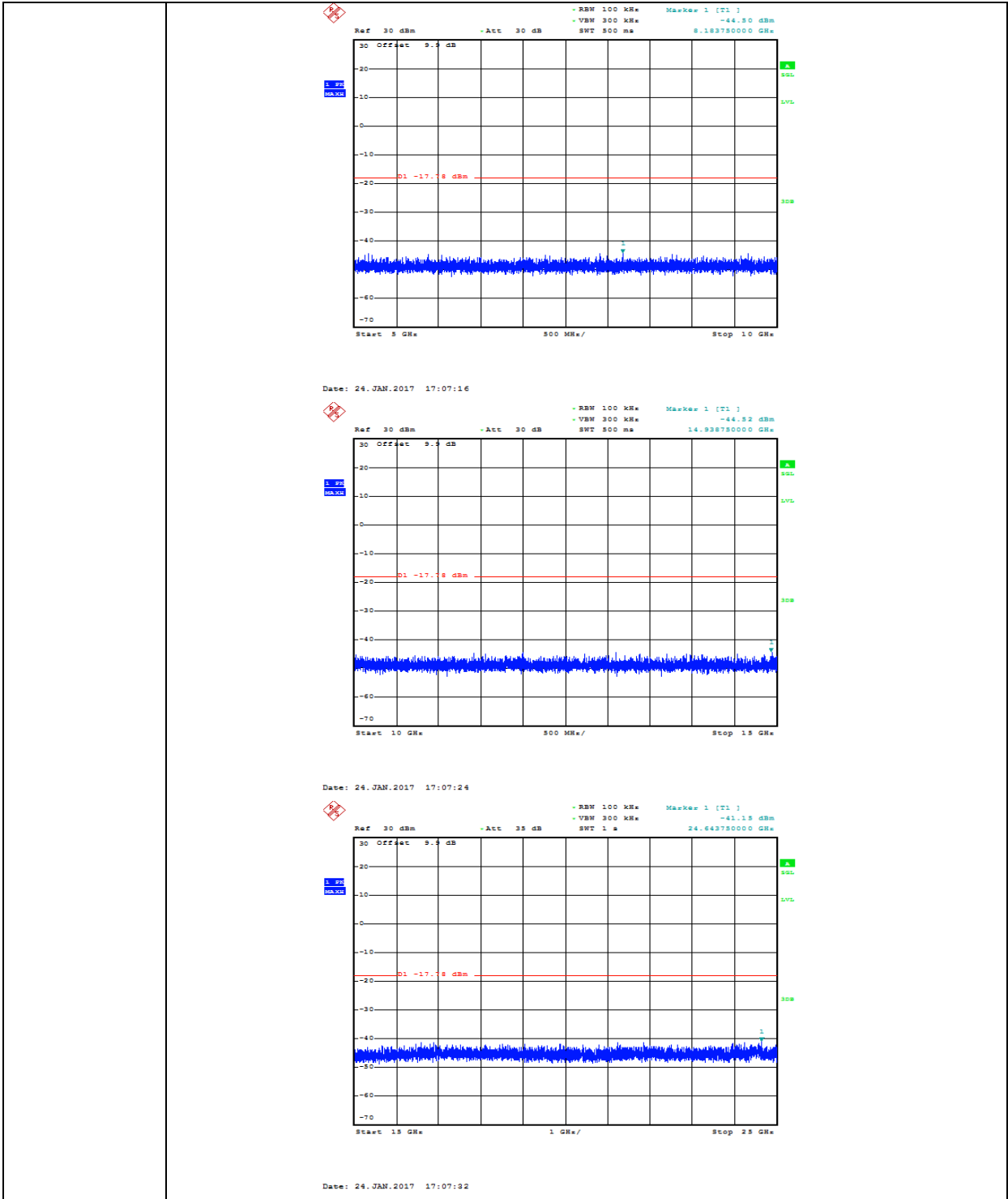

7. Radiated Spurious Emissions

7.1. Block diagram of test setup

In 3m Anechoic Chamber Test Setup Diagram for 9KHz-30MHz

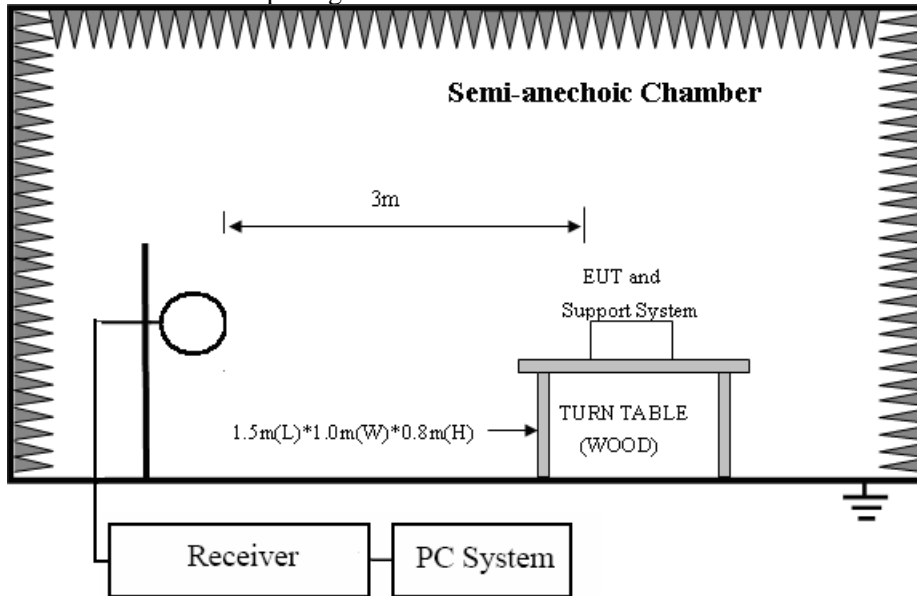

In 3m Anechoic Chamber Test Setup Diagram for 30MHz-1GHz

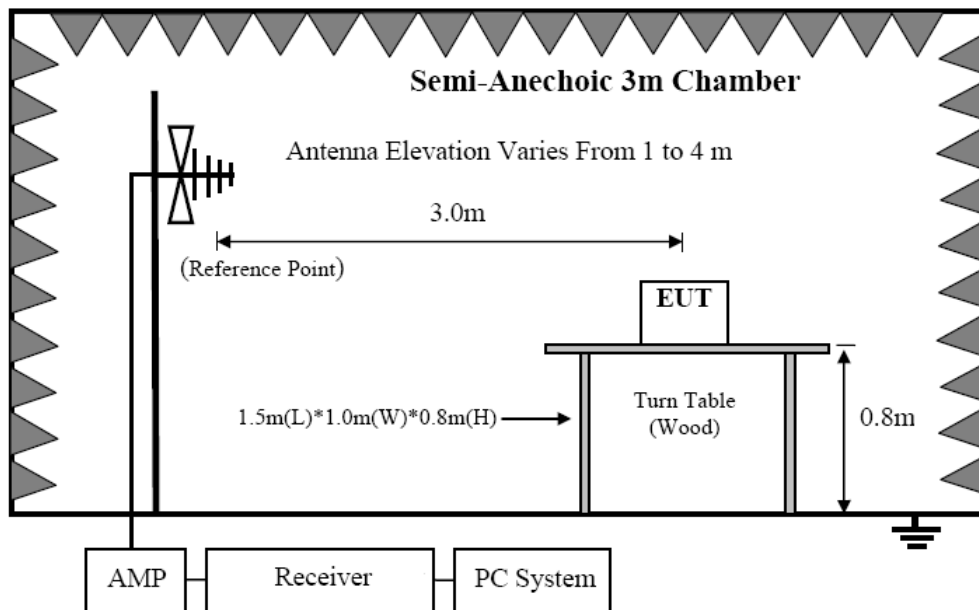

In 3m Anechoic Chamber Test Setup Diagram for frequency above 1GHz

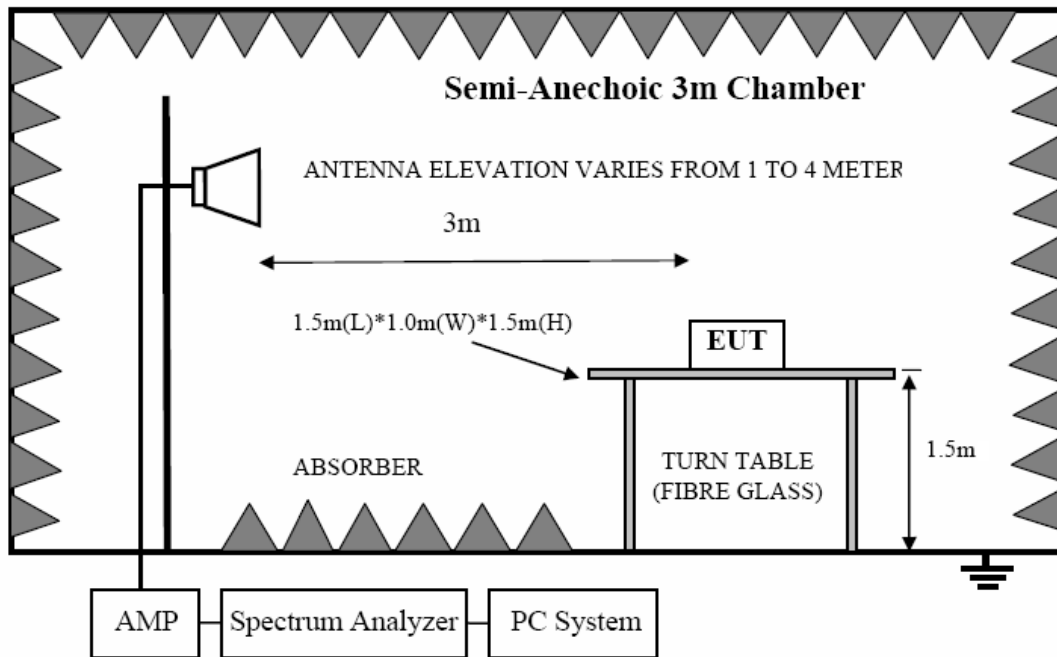

Note: For harmonic emissions test a appropriate high pass filter was inserted in the input port of AMP.

7.2. Limit

8.2.1 FCC 15.205 Restricted frequency band

MHz	MHz	MHz	GHz
0.090 - 0.110	16.42 - 16.423	399.9 - 410	4.5 - 5.15
¹ 0.495 - 0.505	16.69475 - 16.69525	608 - 614	5.35 - 5.46
2.1735 - 2.1905	16.80425 - 16.80475	960 - 1240	7.25 - 7.75
4.125 - 4.128	25.5 - 25.67	1300 - 1427	8.025 - 8.5
4.17725 - 4.17775	37.5 - 38.25	1435 - 1626.5	9.0 - 9.2
4.20725 - 4.20775	73 - 74.6	1645.5 - 1646.5	9.3 - 9.5
6.215 - 6.218	74.8 - 75.2	1660 - 1710	10.6 - 12.7
6.26775 - 6.26825	108 - 121.94	1718.8 - 1722.2	13.25 - 13.4
6.31175 - 6.31225	123 - 138	2200 - 2300	14.47 - 14.5
8.291 - 8.294	149.9 - 150.05	2310 - 2390	15.35 - 16.2
8.362 - 8.366	156.52475 - 156.52525	2483.5 - 2500	17.7 - 21.4
8.37625 - 8.38675	156.7 - 156.9	2690 - 2900	22.01 - 23.12
8.41425 - 8.41475	162.0125 - 167.17	3260 - 3267	23.6 - 24.0
12.29 - 12.293	167.72 - 173.2	3332 - 3339	31.2 - 31.8
12.51975 - 12.52025	240 - 285	3345.8 - 3358	36.43 - 36.5
12.57675 - 12.57725	322 - 335.4	3600 - 4400	(²)

8.2.2 FCC 15.209 Limit.

FREQUENCY MHz	DISTANCE Meters	FIELD STRENGTHS LIMIT	
		μV/m	dB(μV)/m
0.009 ~ 0.490	300	2400/F(KHz)	67.6-20log(F)
0.490 ~ 1.705	30	24000/F(KHz)	87.6-20log(F)
1.705 ~ 30.0	30	30	29.54
30 ~ 88	3	100	40.0
88 ~ 216	3	150	43.5

216 ~ 960	3	200	46.0
960 ~ 1000	3	500	54.0
Above 1000	3	74.0 dB(μ V)/m (Peak) 54.0 dB(μ V)/m (Average)	

Note: (1) The emission limits shown in the above table are based on measurements employing a CISPR QP detector except for the frequency bands 9-90KHz, 110-490KHz and above 1000MHz. Radiated emissions limits in these three bands are based on measurements employing an average detector.

(2) At frequencies below 30MHz, measurement may be performed at a distance closer than that specified, and the limit at closer measurement distance can be extrapolated by below formula:

$$\text{Limit}_{3m}(\text{dBuV/m}) = \text{Limit}_{30m}(\text{dBuV/m}) + 40\text{Log}(30m/3m)$$

8.2.3 Limit for this EUT

All the emissions appearing within 15.205 restricted frequency bands shall not exceed the limits shown in 15.209, all the other emissions shall be at least 20dB below the fundamental emissions, or comply with 15.209 limits.

7.3. Test Procedure

(1) EUT height should be 0.8m for below 1GHz at a semi - anechoic chamber while EUT height should be 1.5m for above 1GHz at full chamber or semi - anechoic chamber ground with absorbers.

(2) The antenna used as below table.

Test frequency range	Test antenna used	Measuring distance
9KHz-30MHz	Active Loop antenna	3 m
30MHz-1GHz	Trilog Broadband Antenna	3 m
1GHz-18GHz	Double Ridged Horn Antenna(1GHz-18GHz)	3 m
18GHz-40GHz	Horn Antenna(18GHz-40GHz)	1 m

According ANSI C63.10:2013 clause 6.4.4.2 and 6.5.3, for measurements below 30 MHz, the loop antenna was positioned with its plane vertical from the EUT and rotated about its vertical axis for maximum response at each azimuth position around the EUT. And the loop antenna also be positioned with its plane horizontal at the specified distance from the EUT. The center of the loop is 1 m above the ground. for measurement above 30MHz, the Trilog Broadband Antenna or Horn Antenna was located 3m from EUT, Measurements were made with the antenna positioned in both the horizontal and vertical planes of Polarization, and the measurement antenna was varied from 1 m to 4 m. in height above the reference ground plane to obtain the maximum signal strength.

(3) Below pre-scan procedure was first performed in order to find prominent frequency spectrum radiated emissions from 9KHz to 25GHz:

(a) Scanning the peak frequency spectrum with the antenna specified in step (3), and the EUT was rotated 360 degree, the antenna height was varied from 1m to 4m(Except loop antenna, it's fixed 1m above ground.)

- (b) Change work frequency or channel of device if practicable.
- (c) Change modulation type of device if practicable.
- (d) Change power supply range from 85% to 115% of the rated supply voltage
- (e) Rotated EUT though three orthogonal axes to determine the attitude of EUT arrangement produces highest emissions.

Spectrum frequency from 9KHz to 25GHz (tenth harmonic of fundamental frequency) was investigated, and no any obvious emission were detected from 18GHz to 25GHz, so below final test was performed with frequency range from 9KHz to 18GHz.

- (4) For final emissions measurements at each frequency of interest, the EUT was rotated and the antenna height was varied between 1m and 4m in order to maximize the emission. Measurements in both horizontal and vertical polarities were made and the data was recorded. In order to find the maximum emission, the relative positions of equipments and all of the interface cables were changed according to ANSI C63.10 2013 on Radiated Emission test.
- (5) The emissions from 9KHz to 1GHz were measured based on CISPR QP detector except for the frequency bands 9-90KHz, 110-490KHz, for emissions from 9KHz-90KHz,110KHz-490KHz and above 1GHz were measured based on average detector, for emissions above 1GHz, peak emissions also be measured and need comply with Peak limit.
- (6) The emissions from 9KHz to 1GHz, QP or average values were measured with EMI receiver with below RBW

Frequency band	RBW
9KHz-150KHz	200Hz
150KHz-30MHz	9KHz
30MHz-1GHz	120KHz

- (7) For emissions above 1GHz, both Peak and Average level were measured with Spectrum Analyzer, and the RBW is set at 1MHz, VBW is set at 3MHz for Peak measure; RMS detector RBW 1MHz VBW 3MHz for Average measure(according ANSI C63.10:2013 clause 4.2.3.2.3 procedure for average measure).

7.4. Test result

PASS. (See below detailed test result)

All the emissions except fundamental emission from 9KHz to 25GHz were comply with 15.209 limit.

Note1: According exploratory test no any obvious emission were detected from 9kHz to 30MHz and 18GHz to 25GHz, so the final test was performed with frequency range from 30MHz to 18GHz and recorded in below.

Note2: For emissions below 1GHz, according exploratory explorer test, when change Tx mode and channel, have no distinct influence on emissions level, so for emissions below 1GHz, the final test was only performed with EUT working in 11b, Tx CH6 mode.

Radiated Emission test (below 1GHz)

TR-4-E-009 Radiated Emission Test Result

Test Site	: DDT 3m Chamber	D:\2017 RE1# Report Data\17Q0119-2\RF.EM6
Test Date	: 2017-01-20	Tested By : Aaron
EUT	: WIFI Player	Model Number : LINK1
Power Supply	: AC 120V/60Hz	Test Mode : Tx mode
Condition	: Temp:24.5°C,Humi:55%, Press:100.1kPa	Antenna/Distance : 2016 VULB9163 1#/3m/VERTICAL
Memo	:	

Data: 1

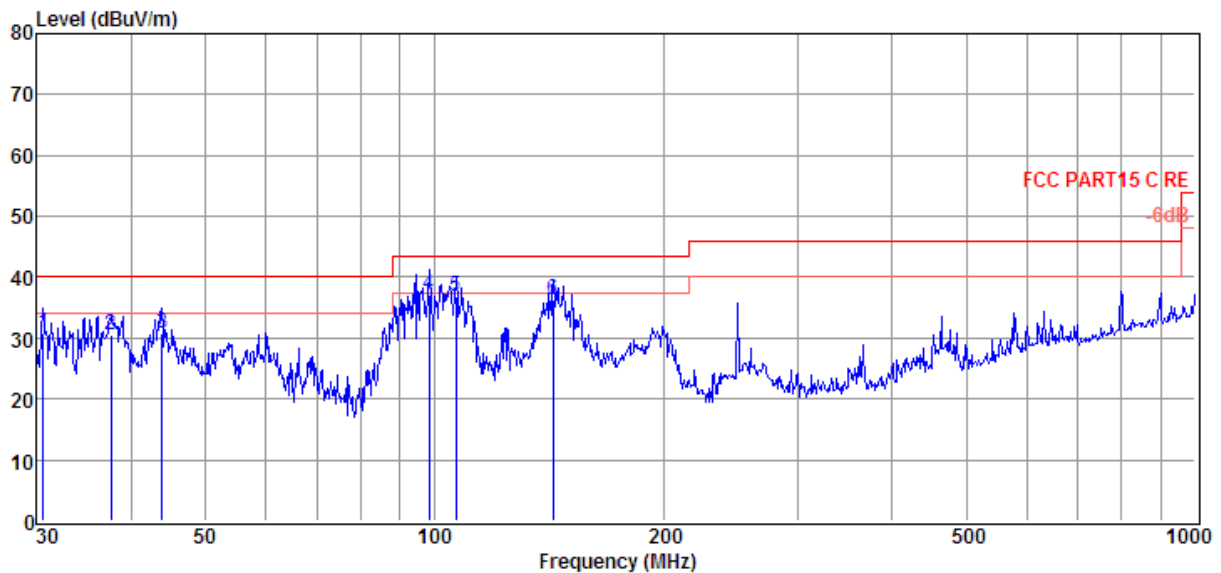

Item (Mark)	Freq. (MHz)	Read Level (dBμV)	Antenna Factor (dB/m)	Cable Loss (dB)	Result Level (dBμV/m)	Limit Line (dBμV/m)	Over Limit (dB)	Detector	Polarization
1	30.64	16.04	11.20	3.68	30.92	40.00	-9.08	QP	VERTICAL
2	37.55	14.76	12.08	3.77	30.61	40.00	-9.39	QP	VERTICAL
3	43.81	14.60	12.41	3.83	30.84	40.00	-9.16	QP	VERTICAL
4	98.49	21.03	11.88	4.28	37.19	43.50	-6.31	QP	VERTICAL
5	106.76	21.05	11.39	4.34	36.78	43.50	-6.72	QP	VERTICAL
6	143.33	24.22	7.40	4.56	36.18	43.50	-7.32	QP	VERTICAL

- Note: 1. Result Level = Read Level + Antenna Factor + Cable loss.
 2. If Peak Result complies with QP limit, QP Result is deemed to comply with QP limit.
 3. Test setup: RBW: 120 kHz, VBW: 300 kHz, Sweep time: auto.

TR-4-E-009 Radiated Emission Test Result

Test Site	: DDT 3m Chamber	D:\2017 RE1# Report Data\17Q0119-2\RF.EM6
Test Date	: 2017-01-20	Tested By : Aaron
EUT	: WIFI Player	Model Number : LINK1
Power Supply	: AC 120V/60Hz	Test Mode : Tx mode
Condition	: Temp:24.5°C,Humi:55%, Press:100.1kPa	Antenna/Distance : 2016 VULB9163 1#/3m/HORIZONTAL
Memo	:	

Data: 2

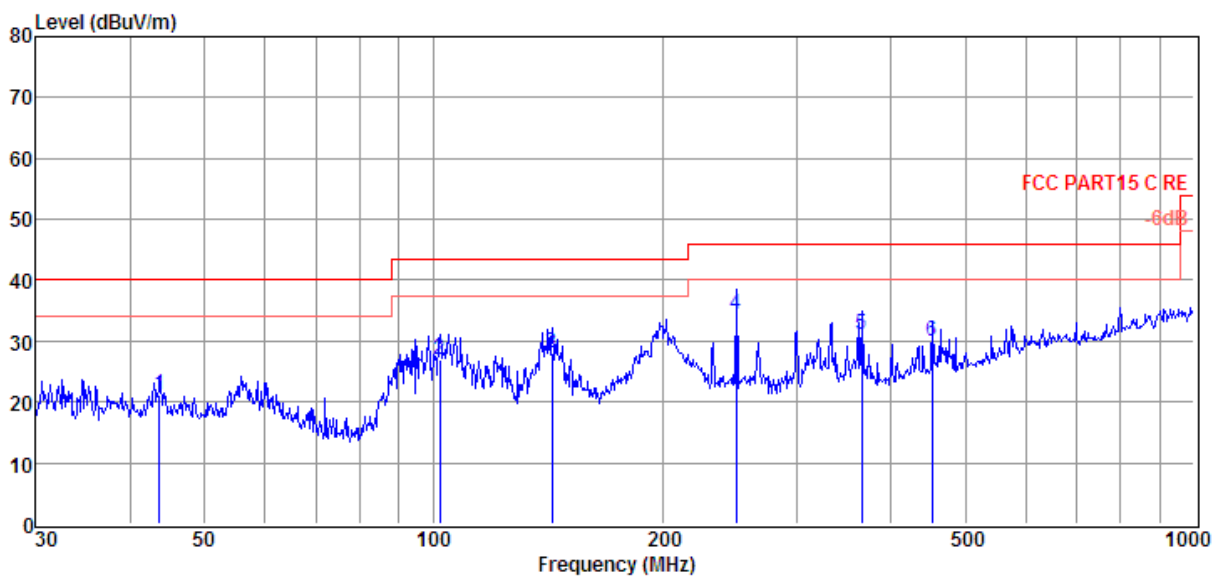

Item (Mark)	Freq. (MHz)	Read Level (dBμV)	Antenna Factor (dB/m)	Cable Loss dB	Result Level (dBμV/m)	Limit Line (dBμV/m)	Over Limit (dB)	Detector	Polarization
1	43.66	5.01	12.42	3.83	21.26	40.00	-18.74	QP	HORIZONTAL
2	102.00	10.81	11.84	4.31	26.96	43.50	-16.54	QP	HORIZONTAL
3	143.33	16.19	7.40	4.56	28.15	43.50	-15.35	QP	HORIZONTAL
4	250.30	16.97	12.30	5.14	34.41	46.00	-11.59	QP	HORIZONTAL
5	365.54	10.19	15.11	5.66	30.96	46.00	-15.04	QP	HORIZONTAL
6	452.72	7.61	16.30	6.00	29.91	46.00	-16.09	QP	HORIZONTAL

- Note: 1. Result Level = Read Level + Antenna Factor + Cable loss.
 2. If Peak Result complies with QP limit, QP Result is deemed to comply with QP limit.
 3. Test setup: RBW: 120 kHz, VBW: 300 kHz, Sweep time: auto.

Radiated Emission test (above 1GHz)

Freq (MHz)	Read level (dB μ V)	Antenna Factor (dB/m)	PRM Factor (dB)	Cable Loss (dB)	Result Level (dB μ V/m)	Limit (dB μ V/m)	Margin (dB)	Detector type	Polarization
11b CH1									
2162.00	39.75	28.83	29.11	5.72	45.19	74.00	-28.81	Peak	HORIZONTAL
2575.00	38.79	30.44	29.88	6.26	45.61	74.00	-28.39	Peak	HORIZONTAL
3926.00	35.05	33.19	29.08	7.57	46.73	74.00	-27.27	Peak	HORIZONTAL
4885.00	33.80	33.72	29.33	8.56	46.75	74.00	-27.25	Peak	HORIZONTAL
6054.00	33.12	35.09	29.23	9.71	48.69	74.00	-25.31	Peak	HORIZONTAL
7622.00	33.39	36.62	30.92	10.92	50.01	74.00	-23.99	Peak	HORIZONTAL
2596.00	37.51	30.51	29.91	6.28	44.39	74.00	-29.61	Peak	VERTICAL
3534.00	34.97	32.01	29.45	7.32	44.85	74.00	-29.15	Peak	VERTICAL
4451.00	33.78	33.76	29.19	8.10	46.45	74.00	-27.55	Peak	VERTICAL
6047.00	32.82	35.08	29.23	9.71	48.38	74.00	-25.62	Peak	VERTICAL
6712.00	33.03	35.97	30.16	10.15	48.99	74.00	-25.01	Peak	VERTICAL
7615.00	33.05	36.62	30.90	10.92	49.69	74.00	-24.31	Peak	VERTICAL
11b CH6									
2582.00	37.94	30.47	29.89	6.26	44.78	74.00	-29.22	Peak	VERTICAL
3919.00	35.27	33.17	29.08	7.55	46.91	74.00	-27.09	Peak	VERTICAL
4871.00	33.48	33.72	29.33	8.54	46.41	74.00	-27.59	Peak	VERTICAL
5669.00	33.15	34.80	29.23	9.36	48.08	74.00	-25.92	Peak	VERTICAL
6803.00	32.42	36.05	30.24	10.24	48.47	74.00	-25.53	Peak	VERTICAL
7321.00	33.35	36.46	30.59	10.71	49.93	74.00	-24.07	Peak	VERTICAL
2162.00	38.35	28.83	29.11	5.72	43.79	74.00	-30.21	Peak	HORIZONTAL
2603.00	38.51	30.53	29.92	6.28	45.40	74.00	-28.60	Peak	HORIZONTAL
3919.00	35.13	33.17	29.08	7.55	46.77	74.00	-27.23	Peak	HORIZONTAL
4577.00	34.74	33.78	29.25	8.24	47.51	74.00	-26.49	Peak	HORIZONTAL
6068.00	33.09	35.11	29.24	9.72	48.68	74.00	-25.32	Peak	HORIZONTAL
6866.00	33.83	36.10	30.30	10.30	49.93	74.00	-24.07	Peak	HORIZONTAL
11b CH11									
2589.00	37.81	30.49	29.90	6.26	44.66	74.00	-29.34	Peak	HORIZONTAL
3947.00	34.70	33.25	29.07	7.58	46.46	74.00	-27.54	Peak	HORIZONTAL
5515.00	31.56	34.71	29.26	9.20	46.21	74.00	-27.79	Peak	HORIZONTAL
6236.00	32.69	35.39	29.40	9.80	48.48	74.00	-25.52	Peak	HORIZONTAL
6796.00	32.65	36.04	30.24	10.24	48.69	74.00	-25.31	Peak	HORIZONTAL
7636.00	32.63	36.63	30.92	10.93	49.27	74.00	-24.73	Peak	HORIZONTAL
4086.88	35.54	33.47	29.06	7.71	47.66	74.00	-26.34	Peak	VERTICAL
4924.00	31.60	33.71	29.34	8.60	44.57	54.00	-9.43	Average	VERTICAL
4924.00	43.39	33.71	29.34	8.60	56.36	74.00	-17.64	Peak	VERTICAL
7386.00	34.70	36.51	30.65	10.75	51.31	74.00	-22.69	Peak	VERTICAL

Note: 1.30MHz~25GHz: (Scan with 11b SISO mode ANT 1 ANT 2, 11g SISO mode ANT 1 ANT 2 mode , and 11n HT20,11n HT40 MIMO mode, the worst case is 11b SISO ANT 1 mode)

2. Result Level = Read Level + Antenna Factor + Cable loss - PRM Factor.

3. Test setup: RBW: 1 MHz, VBW: 3 MHz, Sweep time: auto.

8. Radiated Band Edge Compliance

8.1. Block diagram of test setup

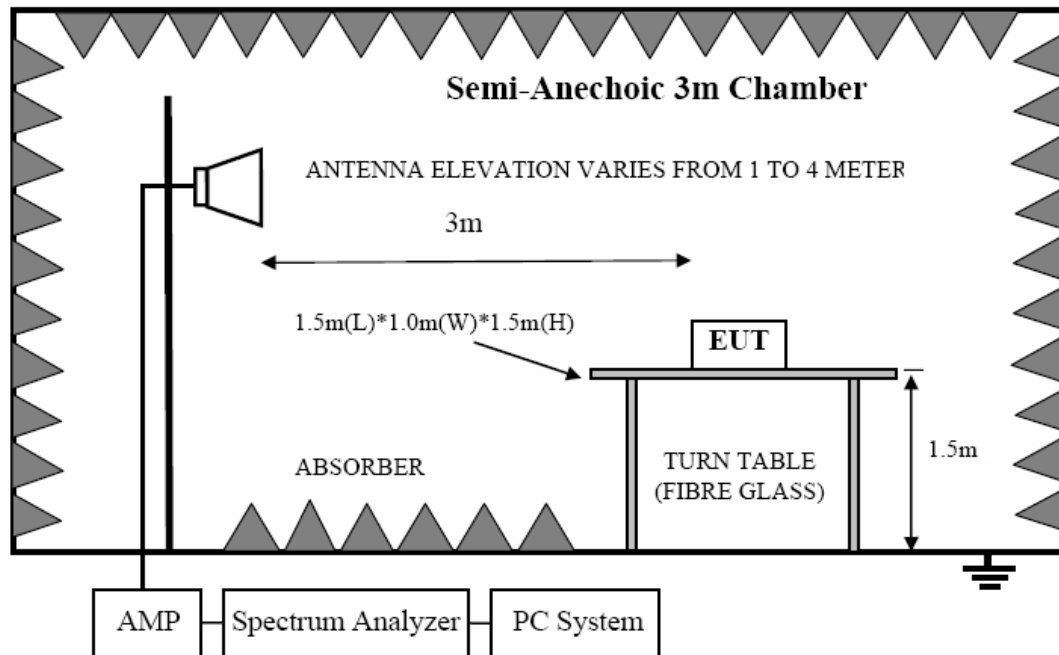

8.2. Limit

All restricted frequency bands shall not exceed the limits shown in 15.209, all the other emissions outside operation frequency band 2400MHz to 2483.5MHz shall be at least 20dB below the fundamental emissions, or comply with RSS-Gen Issue 3 clause 7.2.5 (Same as FCC 15.209) limits.

8.3. Test Procedure

Same with clause 8.3 except change investigated frequency range from 2100MHz to 2450MHz and 2450MHz to 2500MHz.

Remark: All restriction band have been tested, and only the worse case is shown in report.

8.4. Test result

PASS.

(11b, 11g SISO mode ANT 1 ANT 2 mode all have been tested , only Ant 1 mode is worse case and reported ; 11n HT20, 11n HT40 is tested at MIMO mode)

TR-4-E-009 Radiated Emission Test Result

Test Site : DDT 3m Chamber D:\2017 RE1# Report Data\17Q0119-2\RF.EM6
Test Date : 2017-01-23 **Tested By** : Aaron
EUT : WIFI Falyer **Model Number** : LINK1
Power Supply : AC 120V/60Hz **Test Mode** : Tx mode 11b CH1
Condition : Temp:24.5°C,Humi:55%,
 Press:100.1kPa **Antenna/Distance** : 2016 HF907/3m/VERTICAL
Memo :

Data: 7

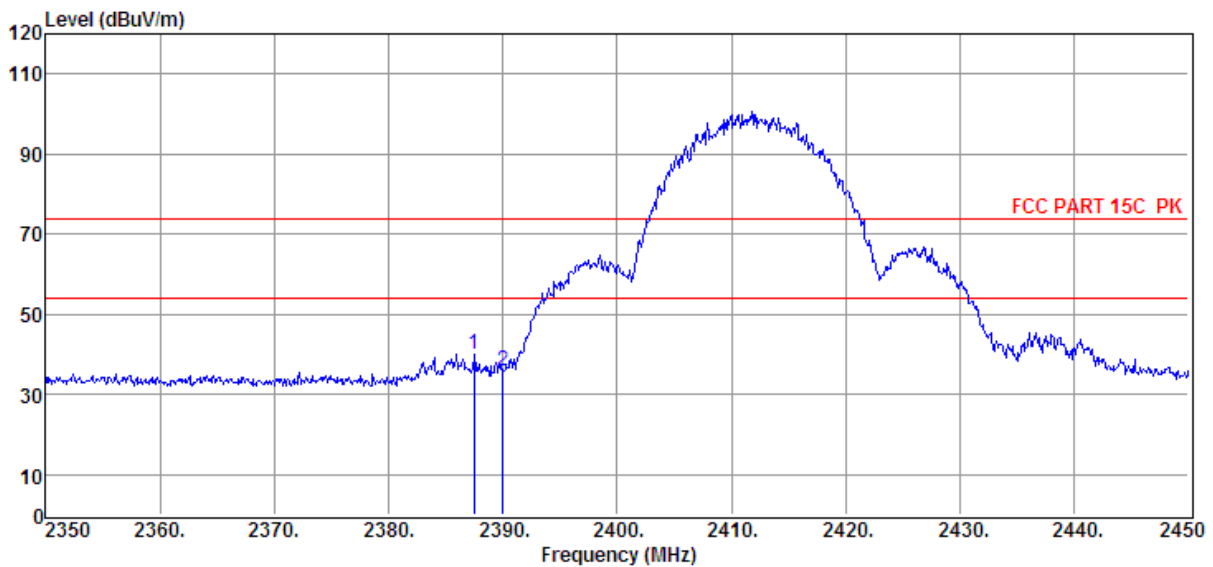

Item (Mark)	Freq. (MHz)	Read Level (dBμV)	Antenna Factor (dB/m)	PRM Factor dB	Cable Loss dB	Result Level (dBμV/m)	Limit Line (dBμV/m)	Over Limit (dB)	Detector	Polarization
1	2387.50	33.81	29.77	29.41	6.01	40.18	74.00	-33.82	Peak	VERTICAL
2	2390.00	29.34	29.78	29.41	6.01	35.72	74.00	-38.28	Peak	VERTICAL

- Note: 1. Result Level = Read Level + Antenna Factor + Cable loss - PRM Factor.
 2. If Peak Result complies with AV limit, AV Result is deemed to comply with AV limit.
 3. Test setup: RBW: 1 MHz, VBW: 3 MHz, Sweep time: auto.

TR-4-E-009 Radiated Emission Test Result

Test Site : DDT 3m Chamber D:\2017 RE1# Report Data\17Q0119-2\RF.EM6
Test Date : 2017-01-23 **Tested By** : Aaron
EUT : WIFI Falyer **Model Number** : LINK1
Power Supply : AC 120V/60Hz **Test Mode** : Tx mode 11b CH1
Condition : Temp:24.5°C,Humi:55%,
 Press:100.1kPa **Antenna/Distance** : 2016 HF907/3m/HORIZONTAL
Memo :

Data: 8

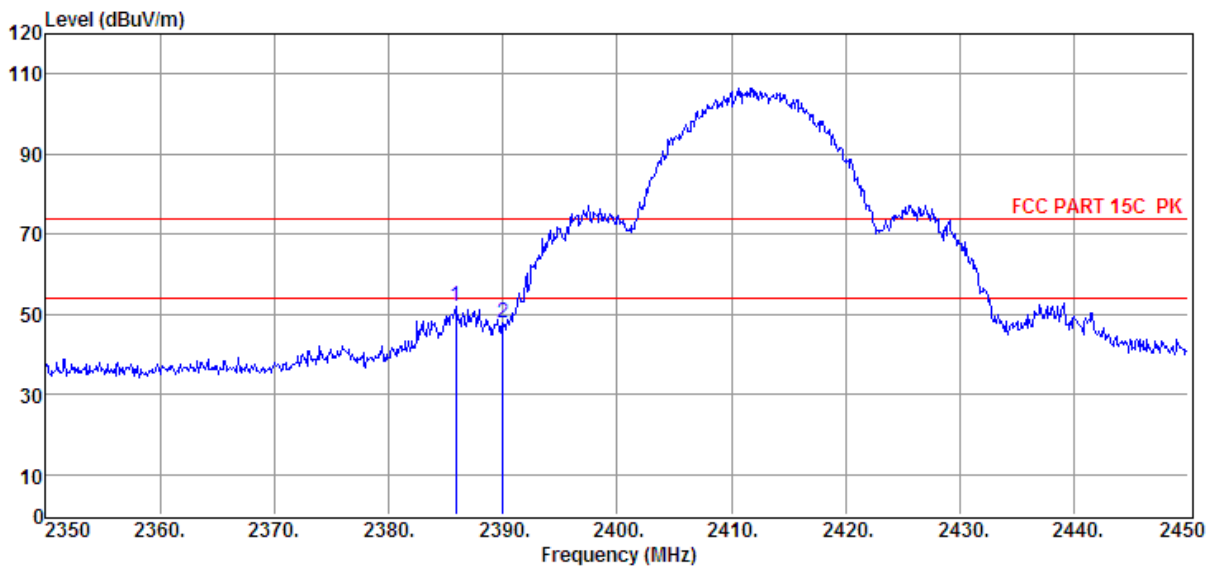

Item (Mark)	Freq. (MHz)	Read Level (dBμV)	Antenna Factor (dB/m)	PRM Factor dB	Cable Loss dB	Result Level (dBμV/m)	Limit Line (dBμV/m)	Over Limit (dB)	Detector	Polarization
1	2385.90	45.62	29.76	29.41	6.01	51.98	74.00	-22.02	Peak	HORIZONTAL
2	2390.00	41.33	29.78	29.41	6.01	47.71	74.00	-26.29	Peak	HORIZONTAL

- Note: 1. Result Level = Read Level + Antenna Factor + Cable loss - PRM Factor.
 2. If Peak Result complies with AV limit, AV Result is deemed to comply with AV limit.
 3. Test setup: RBW: 1 MHz, VBW: 3 MHz, Sweep time: auto.

TR-4-E-009 Radiated Emission Test Result

Test Site : DDT 3m Chamber D:\2017 RE1# Report Data\17Q0119-2\RF.EM6
Test Date : 2017-01-23 **Tested By** : Aaron
EUT : WIFI Falyer **Model Number** : LINK1
Power Supply : AC 120V/60Hz **Test Mode** : Tx mode 11b CH11
Condition : Temp:24.5°C,Humi:55%,
 Press:100.1kPa **Antenna/Distance** : 2016 HF907/3m/HORIZONTAL
Memo :

Data: 9

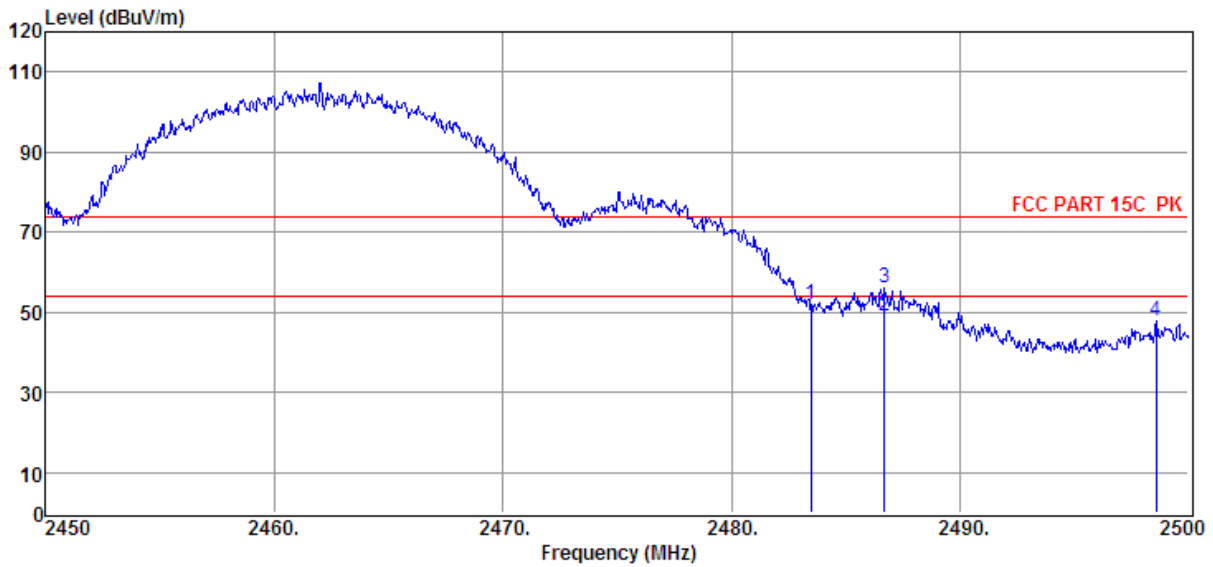

Item (Mark)	Freq. (MHz)	Read Level (dBμV)	Antenna Factor (dB/m)	PRM Factor (dB)	Cable Loss (dB)	Result Level (dBμV/m)	Limit Line (dBμV/m)	Over Limit (dB)	Detector	Polarization
1	2483.50	45.40	30.14	29.71	6.15	51.98	74.00	-22.02	Peak	HORIZONTAL
2	2486.70	42.36	30.15	29.71	6.15	48.95	54.00	-5.05	Average	HORIZONTAL
3	2486.70	49.37	30.15	29.71	6.15	55.96	74.00	-18.04	Peak	HORIZONTAL
4	2498.60	41.31	30.19	29.75	6.15	47.90	74.00	-26.10	Peak	HORIZONTAL

Note: 1. Result Level = Read Level + Antenna Factor + Cable loss - PRM Factor.
 2. If Peak Result complies with AV limit, AV Result is deemed to comply with AV limit.
 3. Test setup: RBW: 1 MHz, VBW: 3 MHz, Sweep time: auto.

TR-4-E-009 Radiated Emission Test Result

Test Site : DDT 3m Chamber D:\2017 RE1# Report Data\17Q0119-2\RF.EM6
Test Date : 2017-01-23 **Tested By** : Aaron
EUT : WIFI Falyer **Model Number** : LINK1
Power Supply : AC 120V/60Hz **Test Mode** : Tx mode 11b CH11
Condition : Temp:24.5°C,Humi:55%,
 Press:100.1kPa **Antenna/Distance** : 2016 HF907/3m/VERTICAL
Memo :

Data: 10

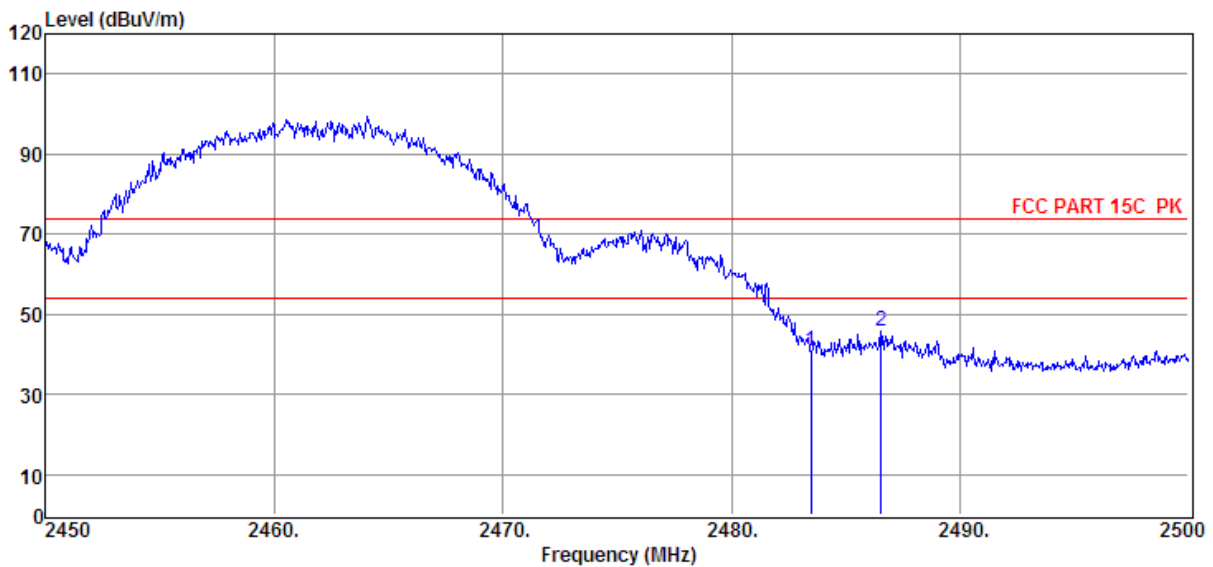

Item (Mark)	Freq. (MHz)	Read Level (dBμV)	Antenna Factor (dB/m)	PRM Factor dB	Cable Loss dB	Result Level (dBμV/m)	Limit Line (dBμV/m)	Over Limit (dB)	Detector	Polarization
1	2483.50	34.10	30.14	29.71	6.15	40.68	74.00	-33.32	Peak	VERTICAL
2	2486.55	39.23	30.15	29.71	6.15	45.82	74.00	-28.18	Peak	VERTICAL

- Note: 1. Result Level = Read Level + Antenna Factor + Cable loss - PRM Factor.
 2. If Peak Result complies with AV limit, AV Result is deemed to comply with AV limit.
 3. Test setup: RBW: 1 MHz, VBW: 3 MHz, Sweep time: auto.

TR-4-E-009 Radiated Emission Test Result

Test Site : DDT 3m Chamber **D:\2017 RE1# Report Data\17Q0119-2\RF.EM6**
Test Date : 2017-01-23 **Tested By** : Aaron
EUT : WIFI Falyer **Model Number** : LINK1
Power Supply : AC 120V/60Hz **Test Mode** : Tx mode 11g CH11
Condition : Temp:24.5°C,Humi:55%,
 Press:100.1kPa **Antenna/Distance** : 2016 HF907/3m/VERTICAL
Memo :

Data: 11

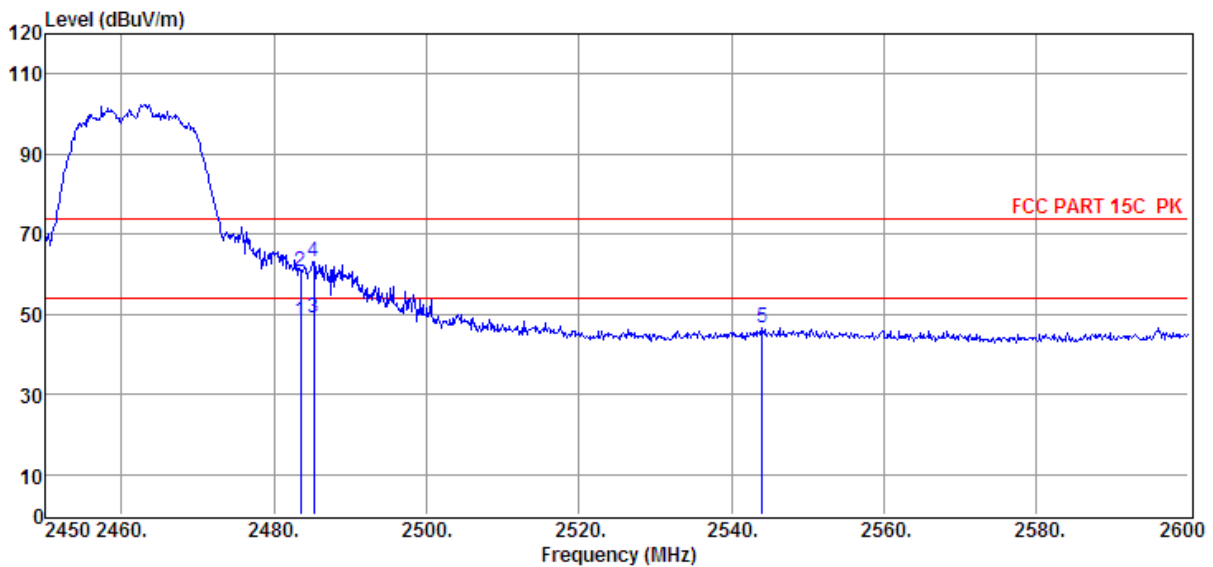

Item (Mark)	Freq. (MHz)	Read Level (dBμV)	Antenna Factor (dB/m)	PRM Factor dB	Cable Loss dB	Result Level (dBμV/m)	Limit Line (dBμV/m)	Over Limit (dB)	Detector	Polarization
1	2483.45	41.64	30.14	29.71	6.15	48.22	54.00	-5.78	Average	VERTICAL
2	2483.45	53.89	30.14	29.71	6.15	60.47	74.00	-13.53	Peak	VERTICAL
3	2485.25	42.60	30.14	29.71	6.15	49.18	54.00	-4.82	Average	VERTICAL
4	2485.25	56.63	30.14	29.71	6.15	63.21	74.00	-10.79	Peak	VERTICAL
5	2544.05	40.01	30.34	29.84	6.22	46.73	74.00	-27.27	Peak	VERTICAL

- Note: 1. Result Level = Read Level + Antenna Factor + Cable loss - PRM Factor.
 2. If Peak Result complies with AV limit, AV Result is deemed to comply with AV limit.
 3. Test setup: RBW: 1 MHz, VBW: 3 MHz, Sweep time: auto.

TR-4-E-009 Radiated Emission Test Result

Test Site : DDT 3m Chamber D:\2017 RE1# Report Data\17Q0119-2\RF.EM6
Test Date : 2017-01-23 **Tested By** : Aaron
EUT : WIFI Falyer **Model Number** : LINK1
Power Supply : AC 120V/60Hz **Test Mode** : Tx mode 11g CH11
Condition : Temp:24.5°C,Humi:55%,
 Press:100.1kPa **Antenna/Distance** : 2016 HF907/3m/HORIZONTAL
Memo :

Data: 12

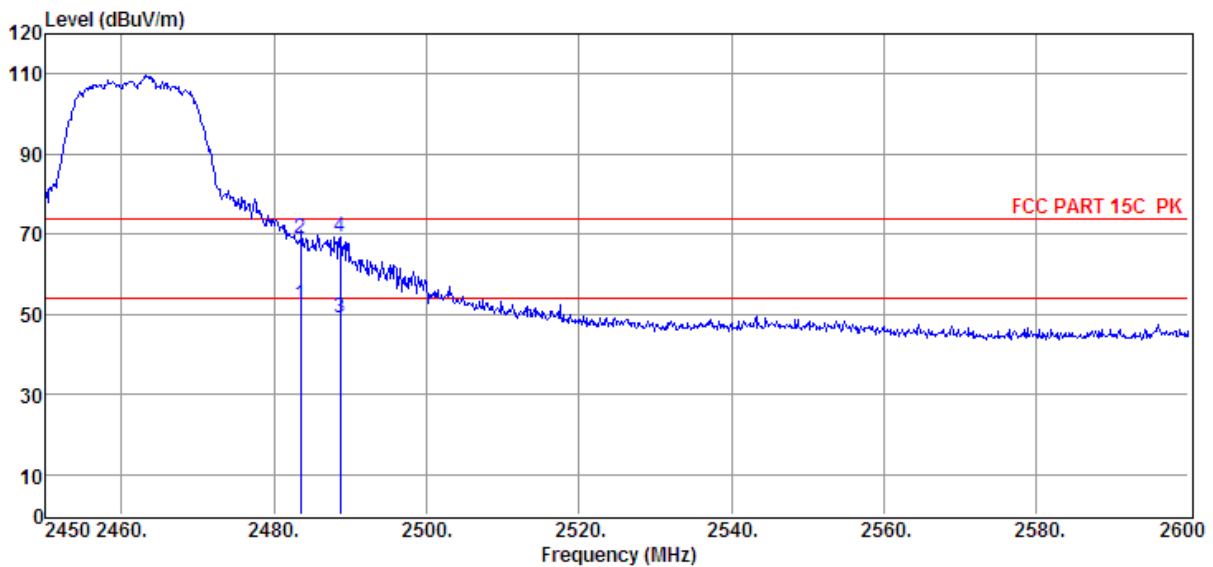

Item (Mark)	Freq. (MHz)	Read Level (dBμV)	Antenna Factor (dB/m)	PRM Factor (dB)	Cable Loss (dB)	Result Level (dBμV/m)	Limit Line (dBμV/m)	Over Limit (dB)	Detector	Polarization
1	2483.45	45.65	30.14	29.71	6.15	52.23	54.00	-1.77	Average	HORIZONTAL
2	2483.45	62.09	30.14	29.71	6.15	68.67	74.00	-5.33	Peak	HORIZONTAL
3	2488.70	42.53	30.16	29.71	6.15	49.13	54.00	-4.87	Average	HORIZONTAL
4	2488.70	62.57	30.16	29.71	6.15	69.17	74.00	-4.83	Peak	HORIZONTAL

- Note: 1. Result Level = Read Level + Antenna Factor + Cable loss - PRM Factor.
 2. If Peak Result complies with AV limit, AV Result is deemed to comply with AV limit.
 3. Test setup: RBW: 1 MHz, VBW: 3 MHz, Sweep time: auto.

TR-4-E-009 Radiated Emission Test Result

Test Site : DDT 3m Chamber D:\2017 RE1# Report Data\17Q0119-2\RF.EM6
Test Date : 2017-01-23 **Tested By** : Aaron
EUT : WIFI Falyer **Model Number** : LINK1
Power Supply : AC 120V/60Hz **Test Mode** : Tx mode 11g CH1
Condition : Temp:24.5°C,Humi:55%,
 Press:100.1kPa **Antenna/Distance** : 2016 HF907/3m/HORIZONTAL
Memo :

Data: 13

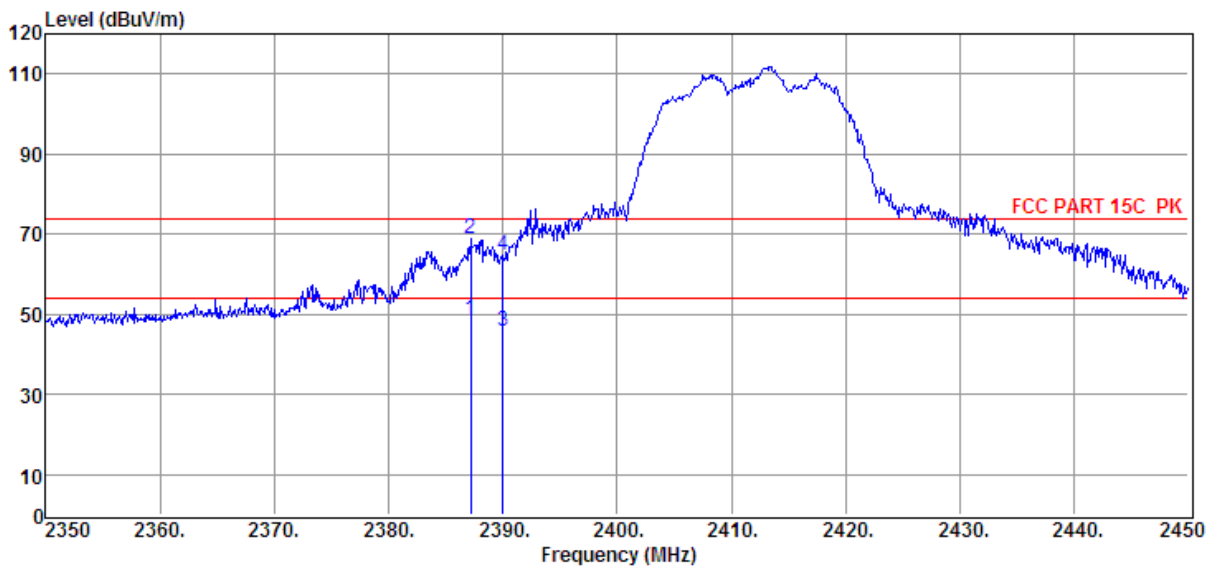

Item (Mark)	Freq. (MHz)	Read Level (dBμV)	Antenna Factor (dB/m)	PRM Factor (dB)	Cable Loss (dB)	Result Level (dBμV/m)	Limit Line (dBμV/m)	Over Limit (dB)	Detector	Polarization
1	2387.20	42.36	29.77	29.41	6.01	48.73	54.00	-5.27	Average	HORIZONTAL
2	2387.20	62.41	29.77	29.41	6.01	68.78	74.00	-5.22	Peak	HORIZONTAL
3	2390.00	39.21	29.78	29.41	6.01	45.59	54.00	-8.41	Average	HORIZONTAL
4	2390.00	58.41	29.78	29.41	6.01	64.79	74.00	-9.21	Peak	HORIZONTAL

Note: 1. Result Level = Read Level + Antenna Factor + Cable loss - PRM Factor.
 2. If Peak Result complies with AV limit, AV Result is deemed to comply with AV limit.
 3. Test setup: RBW: 1 MHz, VBW: 3 MHz, Sweep time: auto.

TR-4-E-009 Radiated Emission Test Result

Test Site : DDT 3m Chamber D:\2017 RE1# Report Data\17Q0119-2\RF.EM6
Test Date : 2017-01-23 **Tested By** : Aaron
EUT : WIFI Falyer **Model Number** : LINK1
Power Supply : AC 120V/60Hz **Test Mode** : Tx mode 11g CH1
Condition : Temp:24.5°C,Humi:55%,
 Press:100.1kPa **Antenna/Distance** : 2016 HF907/3m/VERTICAL
Memo :

Data: 14

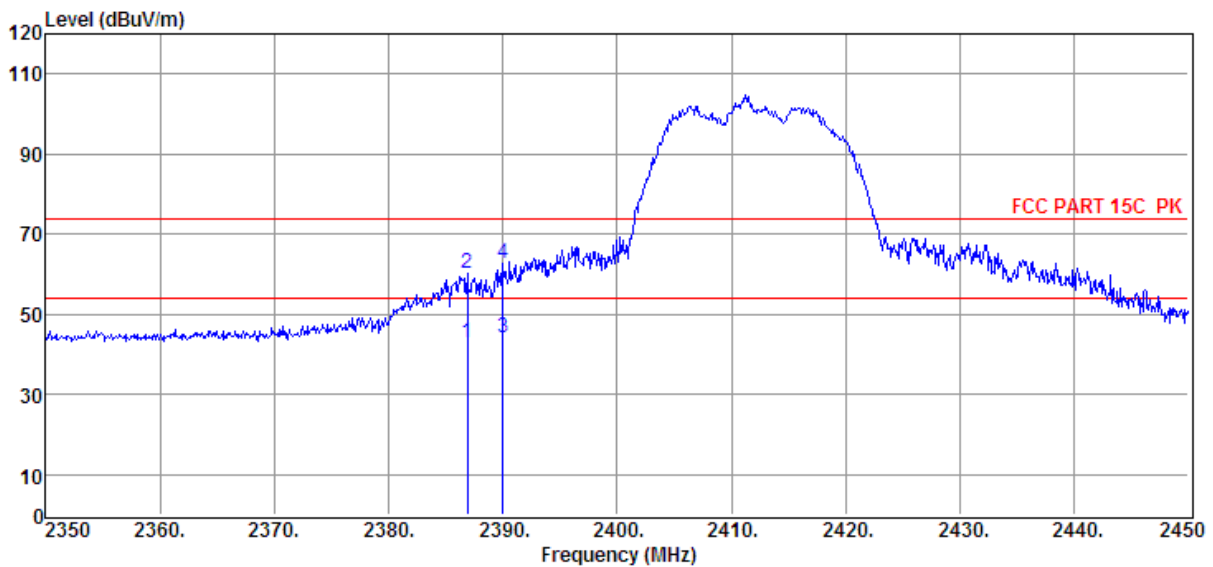

Item (Mark)	Freq. (MHz)	Read Level (dBμV)	Antenna Factor (dB/m)	PRM Factor dB	Cable Loss dB	Result Level (dBμV/m)	Limit Line (dBμV/m)	Over Limit (dB)	Detector	Polarization
1	2386.90	36.54	29.76	29.41	6.01	42.90	54.00	-11.10	Average	VERTICAL
2	2386.90	53.85	29.76	29.41	6.01	60.21	74.00	-13.79	Peak	VERTICAL
3	2390.00	37.56	29.78	29.41	6.01	43.94	54.00	-10.06	Average	VERTICAL
4	2390.00	56.33	29.78	29.41	6.01	62.71	74.00	-11.29	Peak	VERTICAL

Note: 1. Result Level = Read Level + Antenna Factor + Cable loss - PRM Factor.
 2. If Peak Result complies with AV limit, AV Result is deemed to comply with AV limit.
 3. Test setup: RBW: 1 MHz, VBW: 3 MHz, Sweep time: auto.

TR-4-E-009 Radiated Emission Test Result

Test Site : DDT 3m Chamber D:\2017 RE1# Report Data\17Q0119-2\RF.EM6
Test Date : 2017-01-23 **Tested By** : Aaron
EUT : WIFI Falyer **Model Number** : LINK1
Power Supply : AC 120V/60Hz **Test Mode** : Tx mode 11n/20 CH1
Condition : Temp:24.5°C,Humi:55%,
 Press:100.1kPa **Antenna/Distance** : 2016 HF907/3m/VERTICAL
Memo :

Data: 15

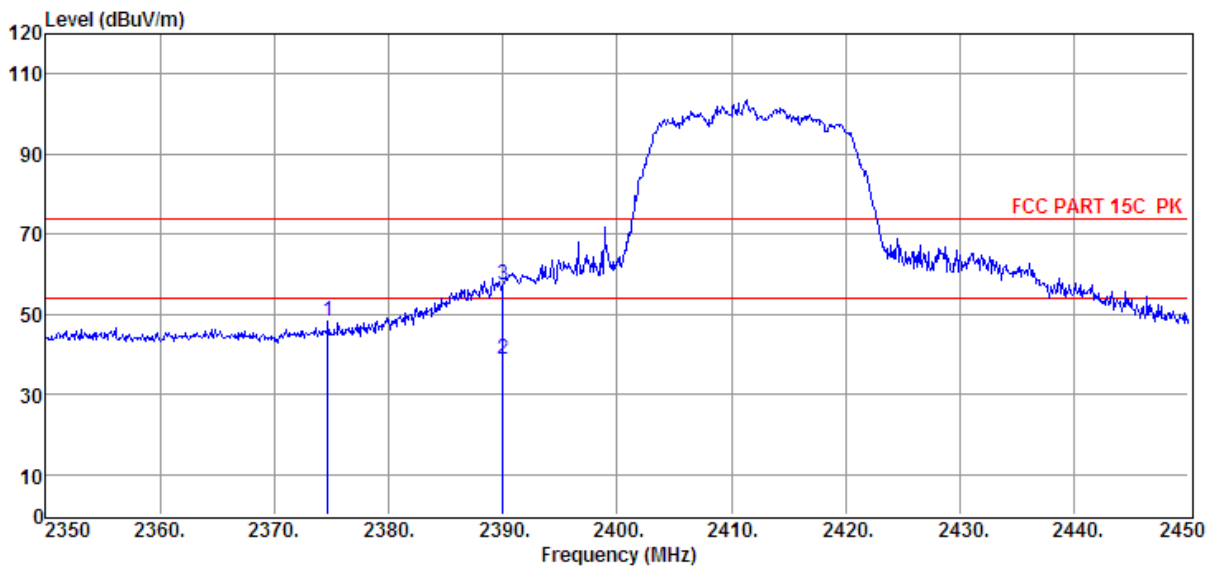

Item (Mark)	Freq. (MHz)	Read Level (dBμV)	Antenna Factor (dB/m)	PRM Factor (dB)	Cable Loss (dB)	Result Level (dBμV/m)	Limit Line (dBμV/m)	Over Limit (dB)	Detector	Polarization
1	2374.70	41.86	29.72	29.38	5.98	48.18	74.00	-25.82	Peak	VERTICAL
2	2390.00	32.54	29.78	29.41	6.01	38.92	54.00	-15.08	Average	VERTICAL
3	2390.00	50.89	29.78	29.41	6.01	57.27	74.00	-16.73	Peak	VERTICAL

Note: 1. Result Level = Read Level + Antenna Factor + Cable loss - PRM Factor.
 2. If Peak Result complies with AV limit, AV Result is deemed to comply with AV limit.
 3. Test setup: RBW: 1 MHz, VBW: 3 MHz, Sweep time: auto.

TR-4-E-009 Radiated Emission Test Result

Test Site : DDT 3m Chamber D:\2017 RE1# Report Data\17Q0119-2\RF.EM6
Test Date : 2017-01-23 **Tested By** : Aaron
EUT : WIFI Falyer **Model Number** : LINK1
Power Supply : AC 120V/60Hz **Test Mode** : Tx mode 11n/20 CH1
Condition : Temp:24.5°C,Humi:55%,
 Press:100.1kPa **Antenna/Distance** : 2016 HF907/3m/HORIZONTAL
Memo :

Data: 16

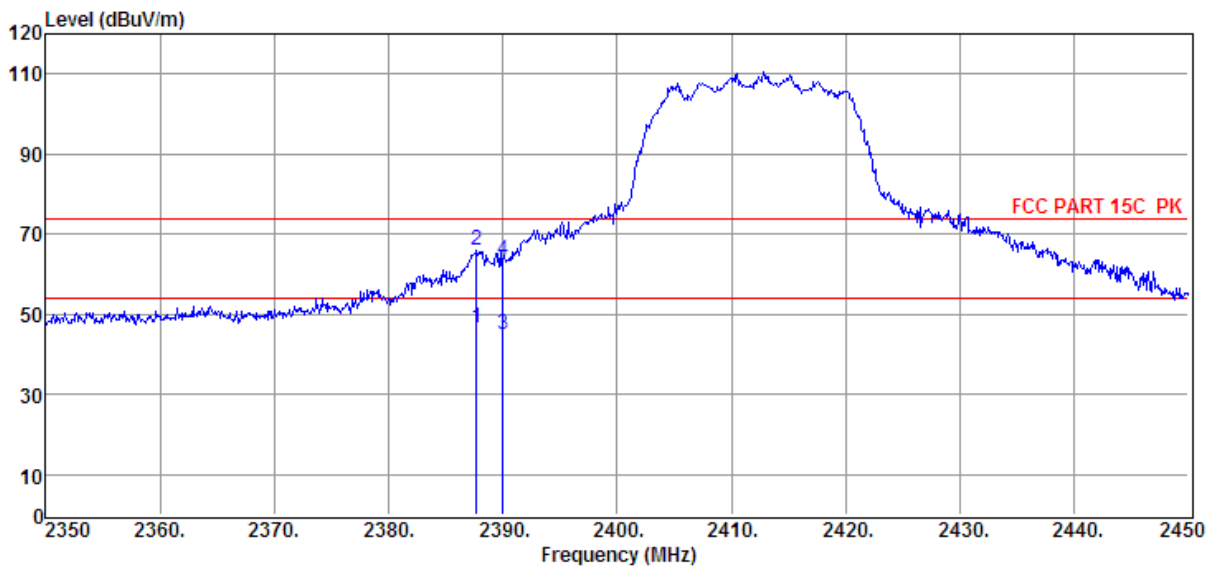

Item (Mark)	Freq. (MHz)	Read Level (dBμV)	Antenna Factor (dB/m)	PRM Factor dB	Cable Loss dB	Result Level (dBμV/m)	Limit Line (dBμV/m)	Over Limit (dB)	Detector	Polarization
1	2387.70	40.25	29.77	29.41	6.01	46.62	54.00	-7.38	Average	HORIZONTAL
2	2387.70	59.56	29.77	29.41	6.01	65.93	74.00	-8.07	Peak	HORIZONTAL
3	2390.00	38.54	29.78	29.41	6.01	44.92	54.00	-9.08	Average	HORIZONTAL
4	2390.00	57.12	29.78	29.41	6.01	63.50	74.00	-10.50	Peak	HORIZONTAL

- Note: 1. Result Level = Read Level + Antenna Factor + Cable loss - PRM Factor.
 2. If Peak Result complies with AV limit, AV Result is deemed to comply with AV limit.
 3. Test setup: RBW: 1 MHz, VBW: 3 MHz, Sweep time: auto.

TR-4-E-009 Radiated Emission Test Result

Test Site : DDT 3m Chamber **D:\2017 RE1# Report Data\17Q0119-2\RF.EM6**
Test Date : 2017-01-23 **Tested By** : Aaron
EUT : WIFI Falyer **Model Number** : LINK1
Power Supply : AC 120V/60Hz **Test Mode** : Tx mode 11n/20 CH11
Condition : Temp:24.5°C,Humi:55%,
 Press:100.1kPa **Antenna/Distance** : 2016 HF907/3m/HORIZONTAL
Memo :

Data: 17

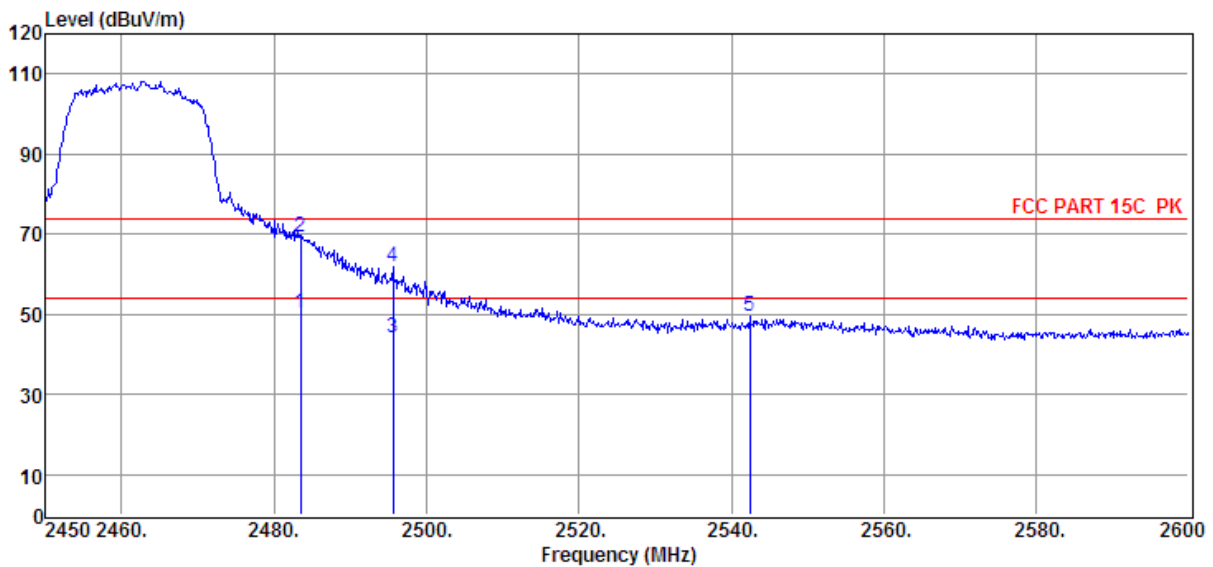

Item (Mark)	Freq. (MHz)	Read Level (dBμV)	Antenna Factor (dB/m)	PRM Factor dB	Cable Loss dB	Result Level (dBμV/m)	Limit Line (dBμV/m)	Over Limit (dB)	Detector	Polarization
1	2483.50	43.64	30.14	29.71	6.15	50.22	54.00	-3.78	Average	HORIZONTAL
2	2483.50	62.75	30.14	29.71	6.15	69.33	74.00	-4.67	Peak	HORIZONTAL
3	2495.60	37.58	30.18	29.73	6.15	44.18	54.00	-9.82	Average	HORIZONTAL
4	2495.60	55.14	30.18	29.73	6.15	61.74	74.00	-12.26	Peak	HORIZONTAL
5	2542.40	42.75	30.34	29.84	6.22	49.47	74.00	-24.53	Peak	HORIZONTAL

- Note: 1. Result Level = Read Level + Antenna Factor + Cable loss - PRM Factor.
 2. If Peak Result complies with AV limit, AV Result is deemed to comply with AV limit.
 3. Test setup: RBW: 1 MHz, VBW: 3 MHz, Sweep time: auto.

TR-4-E-009 Radiated Emission Test Result

Test Site : DDT 3m Chamber D:\2017 RE1# Report Data\17Q0119-2\RF.EM6
Test Date : 2017-01-23 **Tested By** : Aaron
EUT : WIFI Falyer **Model Number** : LINK1
Power Supply : AC 120V/60Hz **Test Mode** : Tx mode 11n/20 CH11
Condition : Temp:24.5°C,Humi:55%,
 Press:100.1kPa **Antenna/Distance** : 2016 HF907/3m/VERTICAL
Memo :

Data: 18

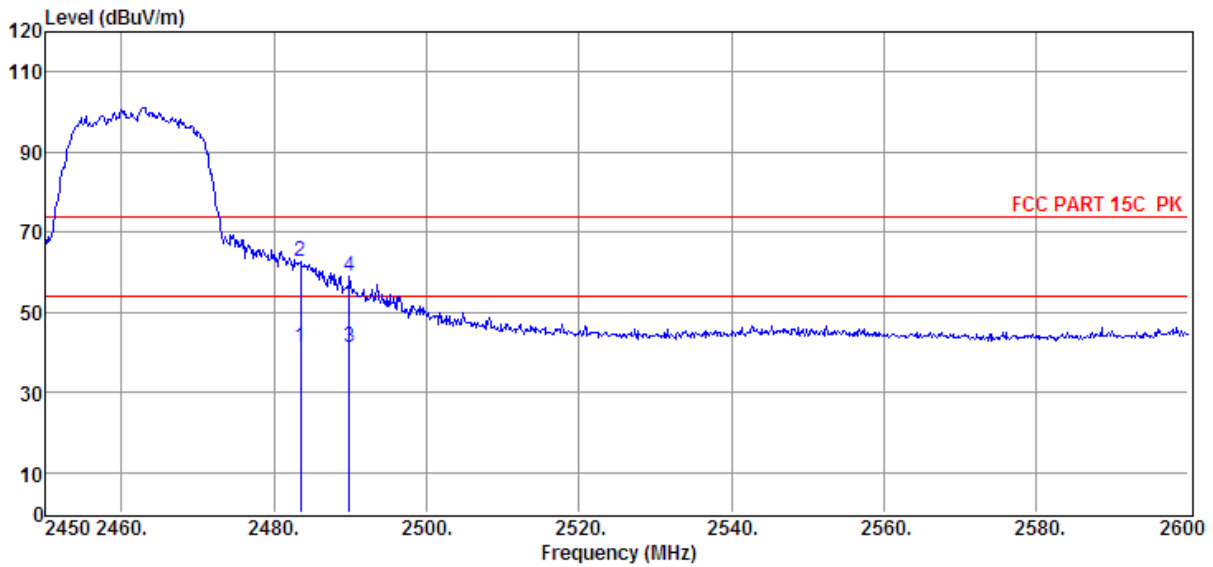

Item (Mark)	Freq. (MHz)	Read Level (dBμV)	Antenna Factor (dB/m)	PRM Factor (dB)	Cable Loss (dB)	Result Level (dBμV/m)	Limit Line (dBμV/m)	Over Limit (dB)	Detector	Polarization
1	2483.50	34.64	30.14	29.71	6.15	41.22	54.00	-12.78	Average	VERTICAL
2	2483.50	55.94	30.14	29.71	6.15	62.52	74.00	-11.48	Peak	VERTICAL
3	2489.90	34.58	30.16	29.73	6.15	41.16	54.00	-12.84	Average	VERTICAL
4	2489.90	52.46	30.16	29.73	6.15	59.04	74.00	-14.96	Peak	VERTICAL

Note: 1. Result Level = Read Level + Antenna Factor + Cable loss - PRM Factor.
 2. If Peak Result complies with AV limit, AV Result is deemed to comply with AV limit.
 3. Test setup: RBW: 1 MHz, VBW: 3 MHz, Sweep time: auto.

TR-4-E-009 Radiated Emission Test Result

Test Site : DDT 3m Chamber D:\2017 RE1# Report Data\17Q0119-2\RF.EM6
Test Date : 2017-01-23 **Tested By** : Aaron
EUT : WIFI Falyer **Model Number** : LINK1
Power Supply : AC 120V/60Hz **Test Mode** : Tx mode 11n/40 CH9
Condition : Temp:24.5°C,Humi:55%,
 Press:100.1kPa **Antenna/Distance** : 2016 HF907/3m/VERTICAL
Memo :

Data: 19

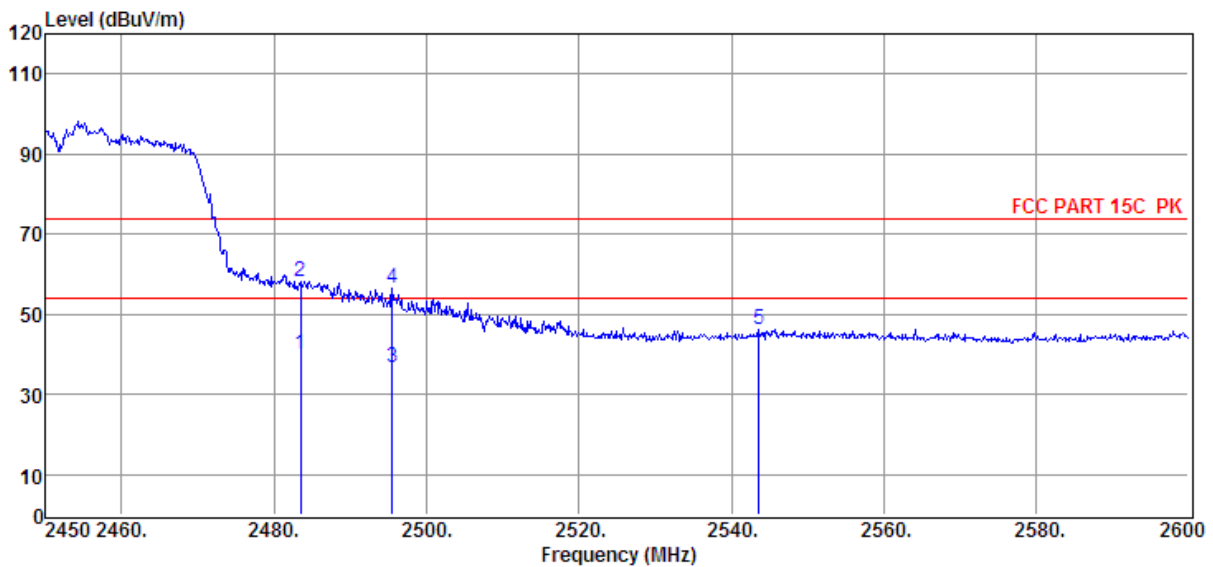

Item (Mark)	Freq. (MHz)	Read Level (dBμV)	Antenna Factor (dB/m)	PRM Factor dB	Cable Loss dB	Result Level (dBμV/m)	Limit Line (dBμV/m)	Over Limit (dB)	Detector	Polarization
1	2483.45	33.53	30.14	29.71	6.15	40.11	54.00	-13.89	Average	VERTICAL
2	2483.45	51.45	30.14	29.71	6.15	58.03	74.00	-15.97	Peak	VERTICAL
3	2495.45	30.25	30.18	29.73	6.15	36.85	54.00	-17.15	Average	VERTICAL
4	2495.45	49.71	30.18	29.73	6.15	56.31	74.00	-17.69	Peak	VERTICAL
5	2543.60	39.51	30.34	29.84	6.22	46.23	74.00	-27.77	Peak	VERTICAL

Note: 1. Result Level = Read Level + Antenna Factor + Cable loss - PRM Factor.
 2. If Peak Result complies with AV limit, AV Result is deemed to comply with AV limit.
 3. Test setup: RBW: 1 MHz, VBW: 3 MHz, Sweep time: auto.

TR-4-E-009 Radiated Emission Test Result

Test Site : DDT 3m Chamber **D:\2017 RE1# Report Data\17Q0119-2\RF.EM6**
Test Date : 2017-01-23 **Tested By** : Aaron
EUT : WIFI Falyer **Model Number** : LINK1
Power Supply : AC 120V/60Hz **Test Mode** : Tx mode 11n/40 CH9
Condition : Temp:24.5°C,Humi:55%,
 Press:100.1kPa **Antenna/Distance** : 2016 HF907/3m/HORIZONTAL
Memo :

Data: 20

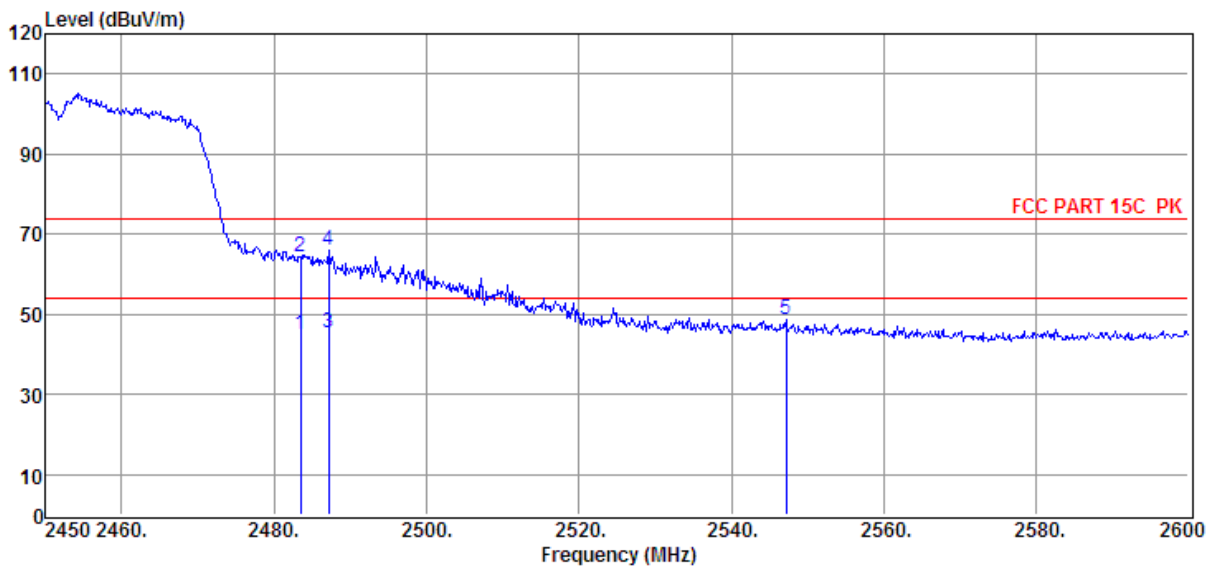

Item (Mark)	Freq. (MHz)	Read Level (dBμV)	Antenna Factor (dB/m)	PRM Factor (dB)	Cable Loss (dB)	Result Level (dBμV/m)	Limit Line (dBμV/m)	Over Limit (dB)	Detector	Polarization
1	2483.50	38.53	30.14	29.71	6.15	45.11	54.00	-8.89	Average	HORIZONTAL
2	2483.50	57.57	30.14	29.71	6.15	64.15	74.00	-9.85	Peak	HORIZONTAL
3	2487.20	38.57	30.15	29.71	6.15	45.16	54.00	-8.84	Average	HORIZONTAL
4	2487.20	59.39	30.15	29.71	6.15	65.98	74.00	-8.02	Peak	HORIZONTAL
5	2547.20	42.03	30.35	29.84	6.22	48.76	74.00	-25.24	Peak	HORIZONTAL

- Note: 1. Result Level = Read Level + Antenna Factor + Cable loss - PRM Factor.
 2. If Peak Result complies with AV limit, AV Result is deemed to comply with AV limit.
 3. Test setup: RBW: 1 MHz, VBW: 3 MHz, Sweep time: auto.

TR-4-E-009 Radiated Emission Test Result

Test Site : DDT 3m Chamber D:\2017 RE1# Report Data\17Q0119-2\RF.EM6
Test Date : 2017-01-23 **Tested By** : Aaron
EUT : WIFI Falyer **Model Number** : LINK1
Power Supply : AC 120V/60Hz **Test Mode** : Tx mode 11n/40 CH3
Condition : Temp:24.5°C,Humi:55%,
 Press:100.1kPa **Antenna/Distance** : 2016 HF907/3m/HORIZONTAL
Memo :

Data: 21

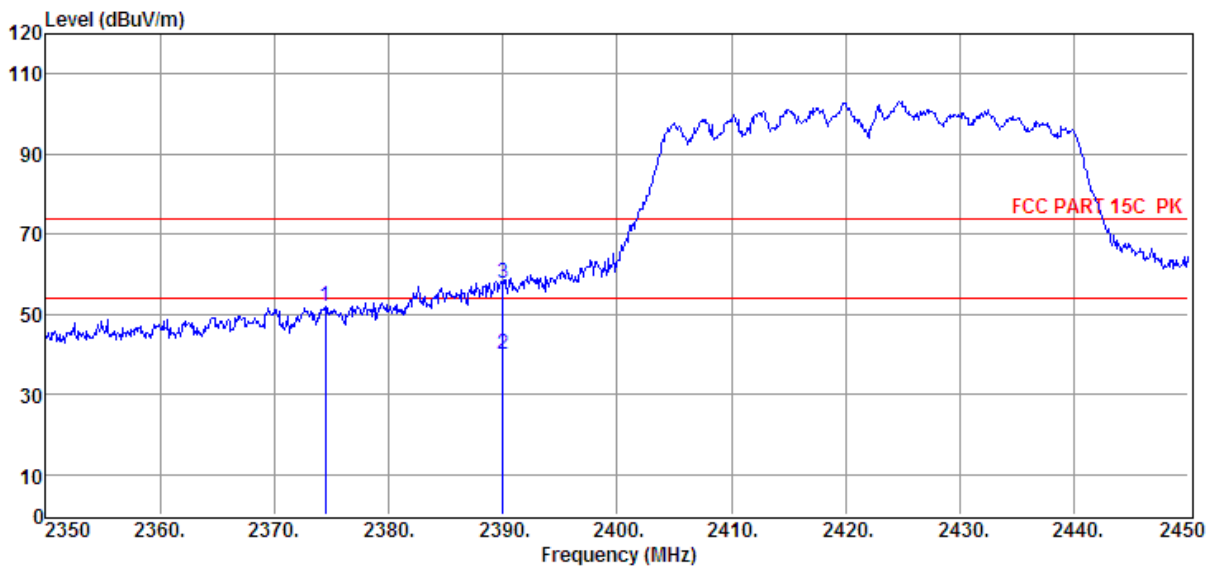

Item (Mark)	Freq. (MHz)	Read Level (dBμV)	Antenna Factor (dB/m)	PRM Factor (dB)	Cable Loss (dB)	Result Level (dBμV/m)	Limit Line (dBμV/m)	Over Limit (dB)	Detector	Polarization
1	2374.50	45.61	29.72	29.38	5.98	51.93	74.00	-22.07	Peak	HORIZONTAL
2	2390.00	33.65	29.78	29.41	6.01	40.03	54.00	-13.97	Average	HORIZONTAL
3	2390.00	51.41	29.78	29.41	6.01	57.79	74.00	-16.21	Peak	HORIZONTAL

Note: 1. Result Level = Read Level + Antenna Factor + Cable loss - PRM Factor.
 2. If Peak Result complies with AV limit, AV Result is deemed to comply with AV limit.
 3. Test setup: RBW: 1 MHz, VBW: 3 MHz, Sweep time: auto.

TR-4-E-009 Radiated Emission Test Result

Test Site : DDT 3m Chamber D:\2017 RE1# Report Data\17Q0119-2\RF.EM6
Test Date : 2017-01-23 **Tested By** : Aaron
EUT : WIFI Falyer **Model Number** : LINK1
Power Supply : AC 120V/60Hz **Test Mode** : Tx mode 11n/40 CH3
Condition : Temp:24.5°C,Humi:55%,
 Press:100.1kPa **Antenna/Distance** : 2016 HF907/3m/VERTICAL
Memo :

Data: 22

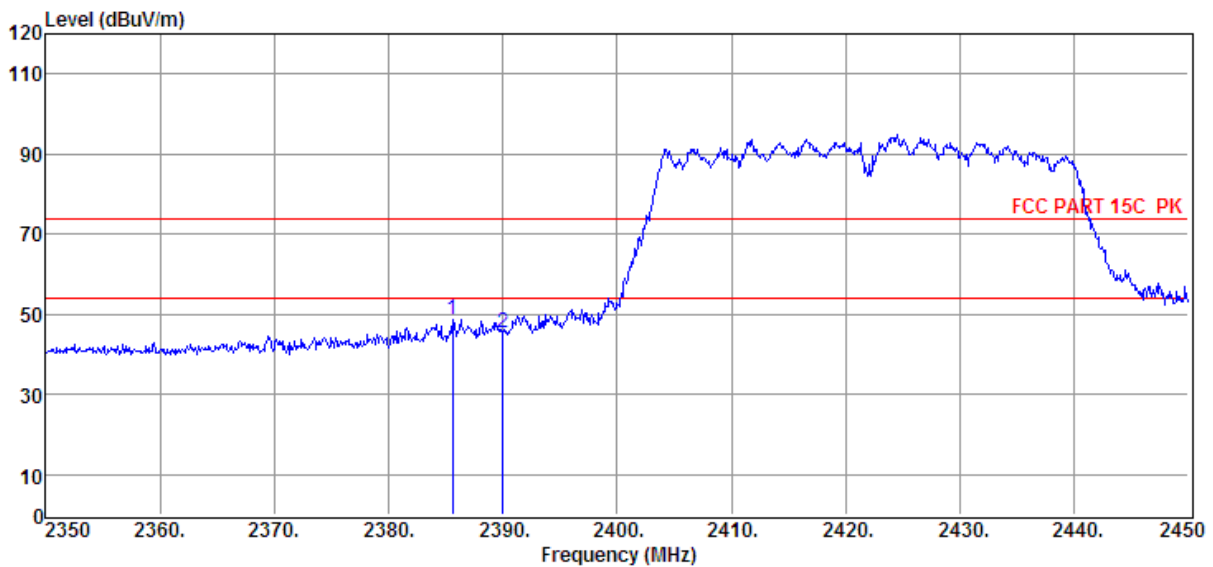

Item (Mark)	Freq. (MHz)	Read Level (dBμV)	Antenna Factor (dB/m)	PRM Factor dB	Cable Loss dB	Result Level (dBμV/m)	Limit Line (dBμV/m)	Over Limit (dB)	Detector	Polarization
1	2385.60	42.37	29.76	29.41	6.01	48.73	74.00	-25.27	Peak	VERTICAL
2	2390.00	38.93	29.78	29.41	6.01	45.31	74.00	-28.69	Peak	VERTICAL

- Note: 1. Result Level = Read Level + Antenna Factor + Cable loss - PRM Factor.
 2. If Peak Result complies with AV limit, AV Result is deemed to comply with AV limit.
 3. Test setup: RBW: 1 MHz, VBW: 3 MHz, Sweep time: auto.

9. Power Line Conducted Emission

9.1. Block diagram of test setup

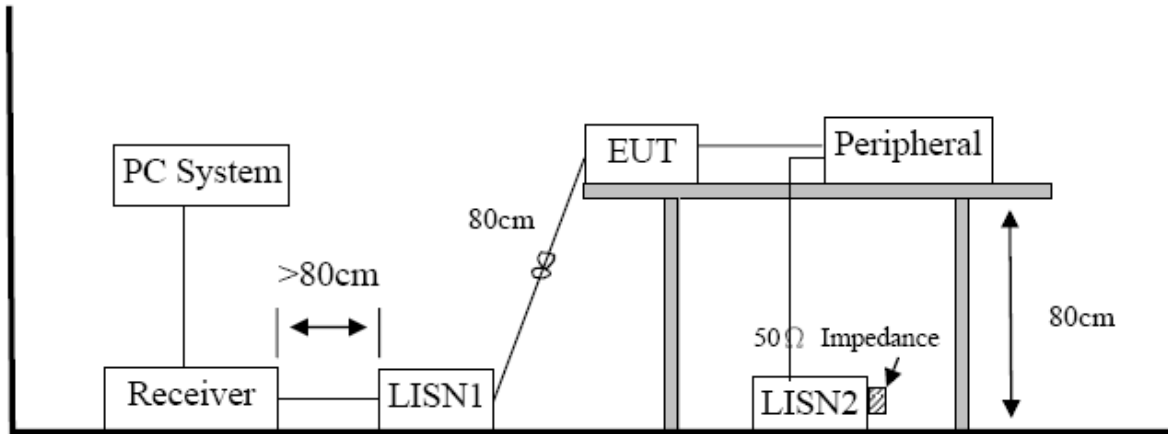

9.2. Power Line Conducted Emission Limits(Class B)

Frequency	Quasi-Peak Level dB(μ V)	Average Level dB(μ V)
150kHz ~ 500kHz	66 ~ 56*	56 ~ 46*
500kHz ~ 5MHz	56	46
5MHz ~ 30MHz	60	50

Note 1: * Decreasing linearly with logarithm of frequency.

Note 2: The lower limit shall apply at the transition frequencies.

9.3. Test Procedure

The EUT and Support equipment, if needed, were put placed on a non-metallic table, 80cm above the ground plane.

All I/O cables were positioned to simulate typical actual usage as per ANSI C63.4.

All support equipment power received from a second LISN.

Emissions were measured on each current carrying line of the EUT using an EMI Test Receiver connected to the LISN powering the EUT.

The Receiver scanned from 150 kHz to 30MHz for emissions in each of the test modes.

During the above scans, the emissions were maximized by cable manipulation.

After the preliminary scan, we found the test mode producing the highest emission level.

The EUT configuration and worse cable configuration of the above highest emission levels were recorded for reference of the final test.

EUT and support equipment were set up on the test bench as per the configuration with highest emission

level in the preliminary test.

A scan was taken on both power lines, Neutral and Line, recording at least the six highest emissions.

Emission frequency and amplitude were recorded into a computer in which correction factors were used to calculate the emission level and compare reading to the applicable limit.

The test data of the worst-case condition(s) was recorded.

The bandwidth of test receiver is set at 9 KHz.

9.4. Test Result

PASS. (See below detailed test result)

Note1: All emissions not reported below are too low against the prescribed limits.

Note2: “----” means peak detection; “-----” mans average detection

TR-4-E-010 Conducted Emission Test Result

Test Site	: DDT 1# Shield Room	E:\2017 CE report data\17Q0119-2\CE.EM6	
Test Date	: 2017-01-20	Tested By	: Jerry
EUT	: WIFI Player	Model Number	: LINK1
Power Supply	: AC 120V/60Hz	Test Mode	: Tx mode
Condition	: Temp:24.5°C,Humi:55%, Press:100.1kPa	LISN	: 2016 ENV216/NEUTRAL

Data: 6

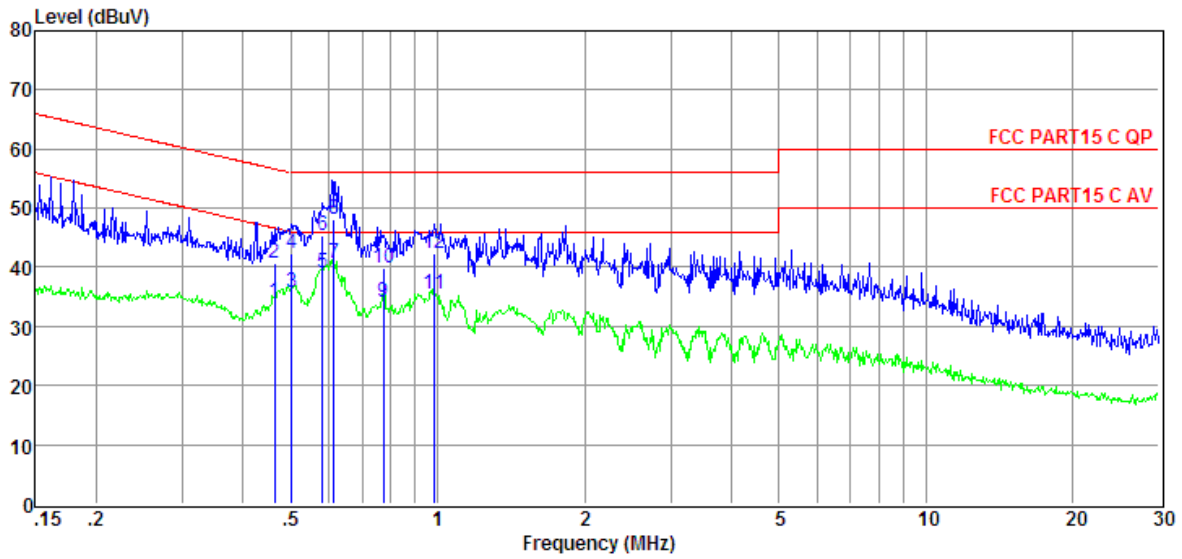

Item (Mark)	Freq. (MHz)	Read Level (dBμV)	LISN Factor (dB)	Cable Loss (dB)	Pulse Limiter Factor (dB)	Result Level (dBμV)	Limit Line (dBμV)	Over Limit (dB)	Detector	Phase
1	0.464	14.64	9.61	0.02	9.86	34.13	46.63	-12.50	Average	NEUTRAL
2	0.464	21.27	9.61	0.02	9.86	40.76	56.63	-15.87	QP	NEUTRAL
3	0.502	16.28	9.61	0.02	9.86	35.77	46.00	-10.23	Average	NEUTRAL
4	0.502	22.98	9.61	0.02	9.86	42.47	56.00	-13.53	QP	NEUTRAL
5	0.582	19.65	9.61	0.03	9.86	39.15	46.00	-6.85	Average	NEUTRAL
6	0.582	25.83	9.61	0.03	9.86	45.33	56.00	-10.67	QP	NEUTRAL
7	0.613	21.20	9.61	0.03	9.86	40.70	46.00	-5.30	Average	NEUTRAL
8	0.613	28.60	9.61	0.03	9.86	48.10	56.00	-7.90	QP	NEUTRAL
9	0.775	14.67	9.61	0.03	9.86	34.17	46.00	-11.83	Average	NEUTRAL
10	0.775	20.23	9.61	0.03	9.86	39.73	56.00	-16.27	QP	NEUTRAL
11	0.984	15.83	9.61	0.03	9.86	35.33	46.00	-10.67	Average	NEUTRAL
12	0.984	22.76	9.61	0.03	9.86	42.26	56.00	-13.74	QP	NEUTRAL

- Note: 1. Result Level = Read Level + LISN Factor + Pulse Limiter Factor + Cable loss.
 2. If QP Result complies with AV limit, AV Result is deemed to comply with AV limit.
 3. Test setup: RBW: 200 Hz (9 kHz—150 kHz), 9 kHz (150 kHz—30 MHz).
 4. Step size: 80Hz (0.009MHz-0.15MHz), 4 kHz (0.15MHz-30MHz), Scan time: auto.

TR-4-E-010 Conducted Emission Test Result

Test Site	: DDT 1# Shield Room	E:\2017 CE report data\17Q0119-2\CE.EM6
Test Date	: 2017-01-20	Tested By : Jerry
EUT	: WIFI Player	Model Number : LINK1
Power Supply	: AC 120V/60Hz	Test Mode : Tx mode
Condition	: Temp:24.5°C,Humi:55%, Press:100.1kPa	LISN : 2016 ENV216/LINE

Data: 8

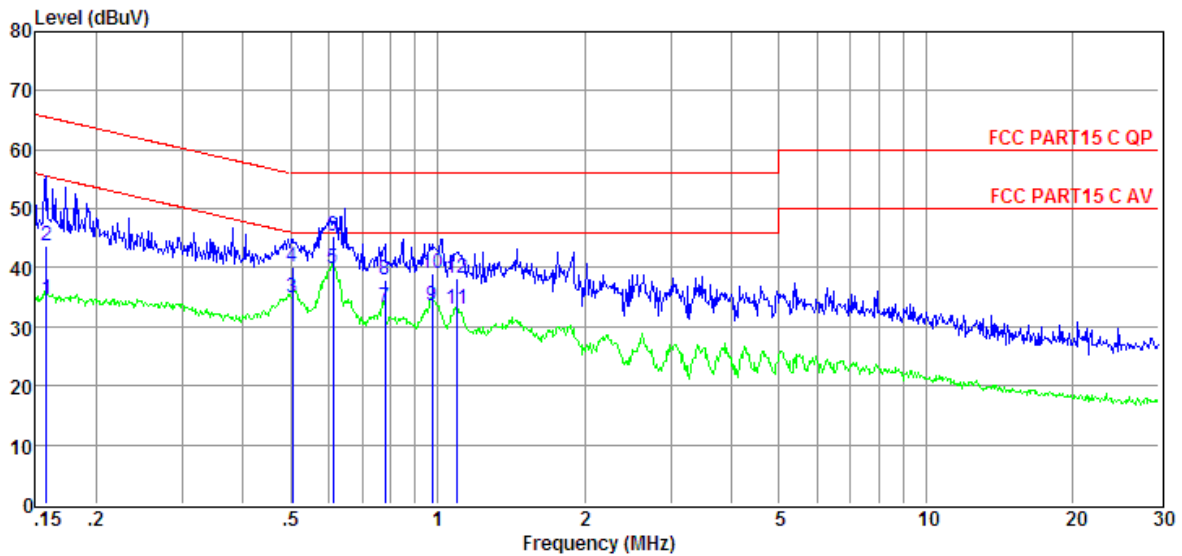

Item (Mark)	Freq. (MHz)	Read Level (dBμV)	LISN Factor (dB)	Cable Loss (dB)	Pulse Limiter Factor (dB)	Result Level (dBμV)	Limit Line (dBμV)	Over Limit (dB)	Detector	Phase
1	0.158	15.03	9.61	0.02	9.86	34.52	55.56	-21.04	Average	LINE
2	0.158	24.22	9.61	0.02	9.86	43.71	65.56	-21.85	QP	LINE
3	0.505	15.47	9.61	0.02	9.86	34.96	46.00	-11.04	Average	LINE
4	0.505	20.69	9.61	0.02	9.86	40.18	56.00	-15.82	QP	LINE
5	0.611	20.29	9.61	0.03	9.86	39.79	46.00	-6.21	Average	LINE
6	0.611	25.77	9.61	0.03	9.86	45.27	56.00	-10.73	QP	LINE
7	0.779	13.67	9.61	0.03	9.86	33.17	46.00	-12.83	Average	LINE
8	0.779	18.44	9.61	0.03	9.86	37.94	56.00	-18.06	QP	LINE
9	0.974	14.13	9.61	0.03	9.86	33.63	46.00	-12.37	Average	LINE
10	0.974	19.51	9.61	0.03	9.86	39.01	56.00	-16.99	QP	LINE
11	1.094	13.40	9.61	0.03	9.86	32.90	46.00	-13.10	Average	LINE
12	1.094	18.78	9.61	0.03	9.86	38.28	56.00	-17.72	QP	LINE

- Note: 1. Result Level = Read Level + LISN Factor + Pulse Limiter Factor + Cable loss.
 2. If QP Result complies with AV limit, AV Result is deemed to comply with AV limit.
 3. Test setup: RBW: 200 Hz (9 kHz—150 kHz), 9 kHz (150 kHz—30 MHz).
 4. Step size: 80Hz (0.009MHz-0.15MHz), 4 kHz (0.15MHz-30MHz), Scan time: auto.

10. Antenna Requirements

10.1. Limit

For intentional device, according to FCC 47 CFR Section 15.203, an intentional radiator shall be designed to ensure that no antenna other than that furnished by the responsible party shall be used with the device. And according to FCC 47 CFR Section 15.247 (b), if transmitting antennas of directional gain greater than 6dBi are used, the power shall be reduced by the amount in dB that the directional gain of the antenna exceeds 6dBi.

10.2. Result

Compliance

See page 6 2.1

11. Test setup photograph

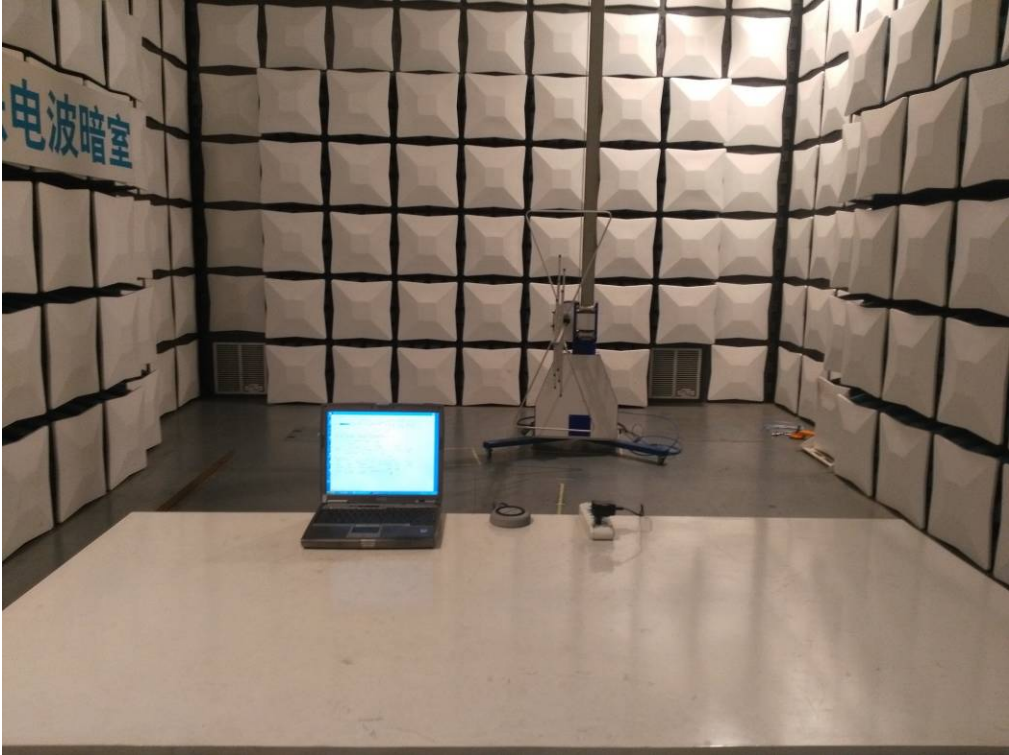



12. Photos of the EUT



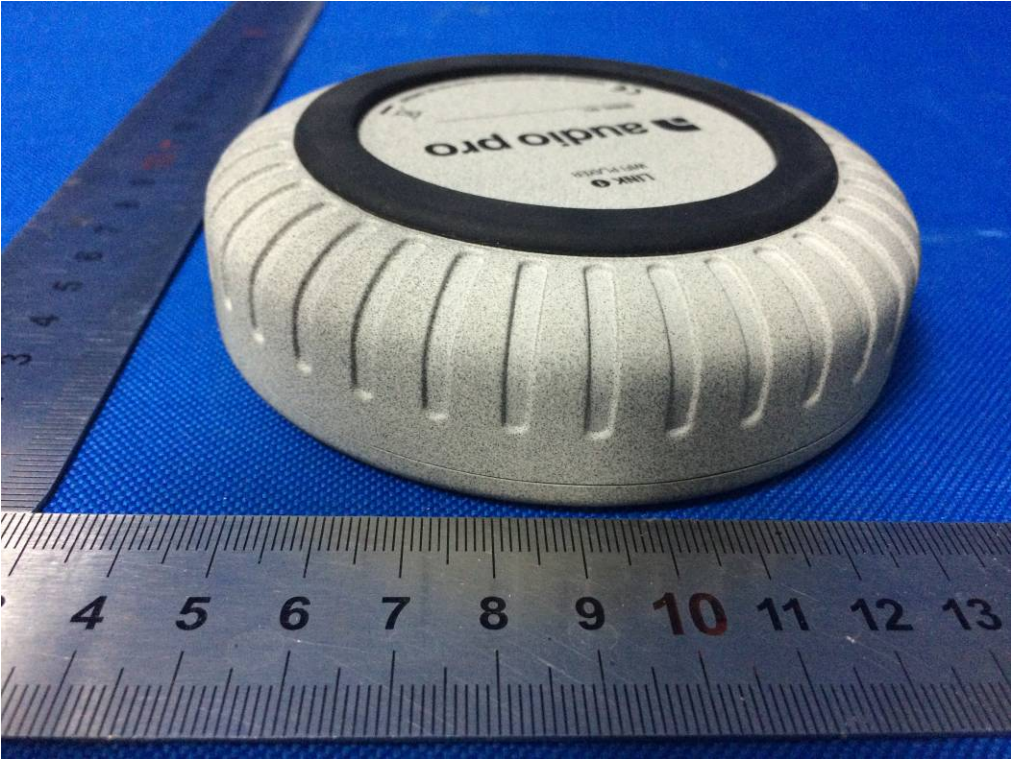
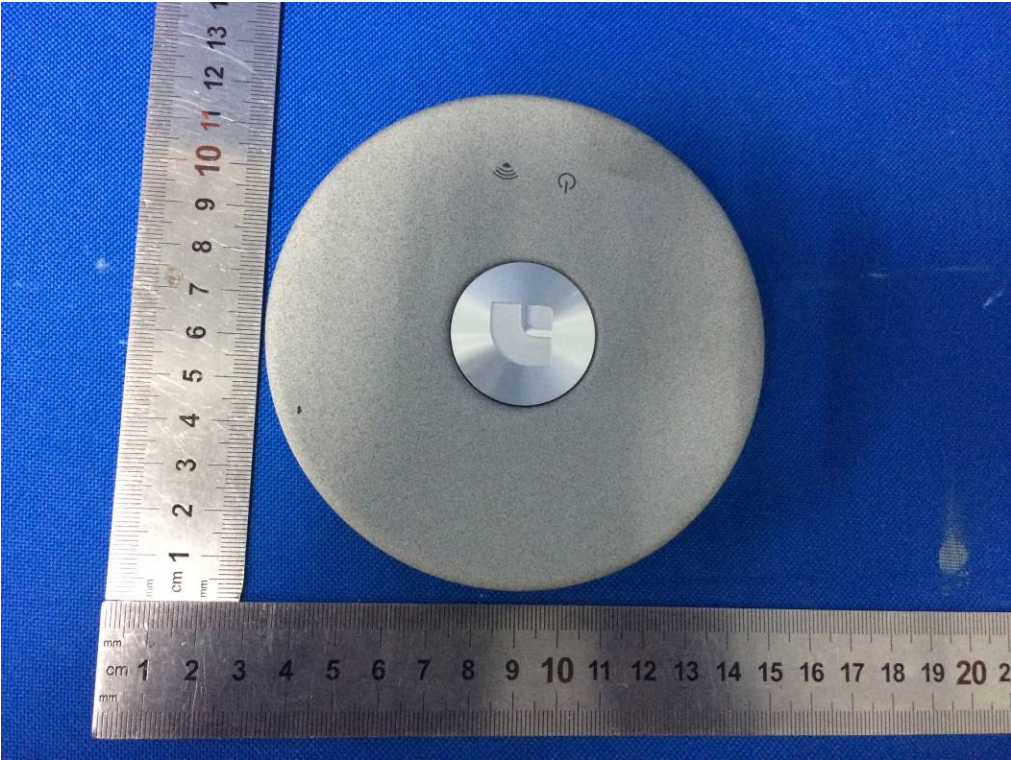



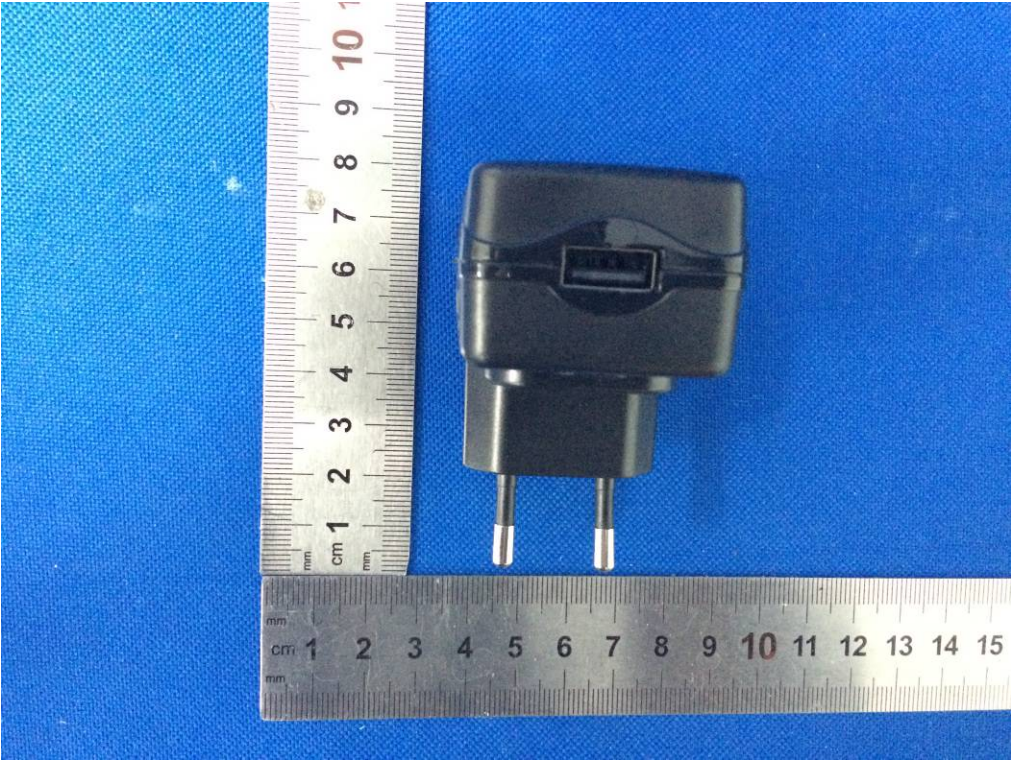



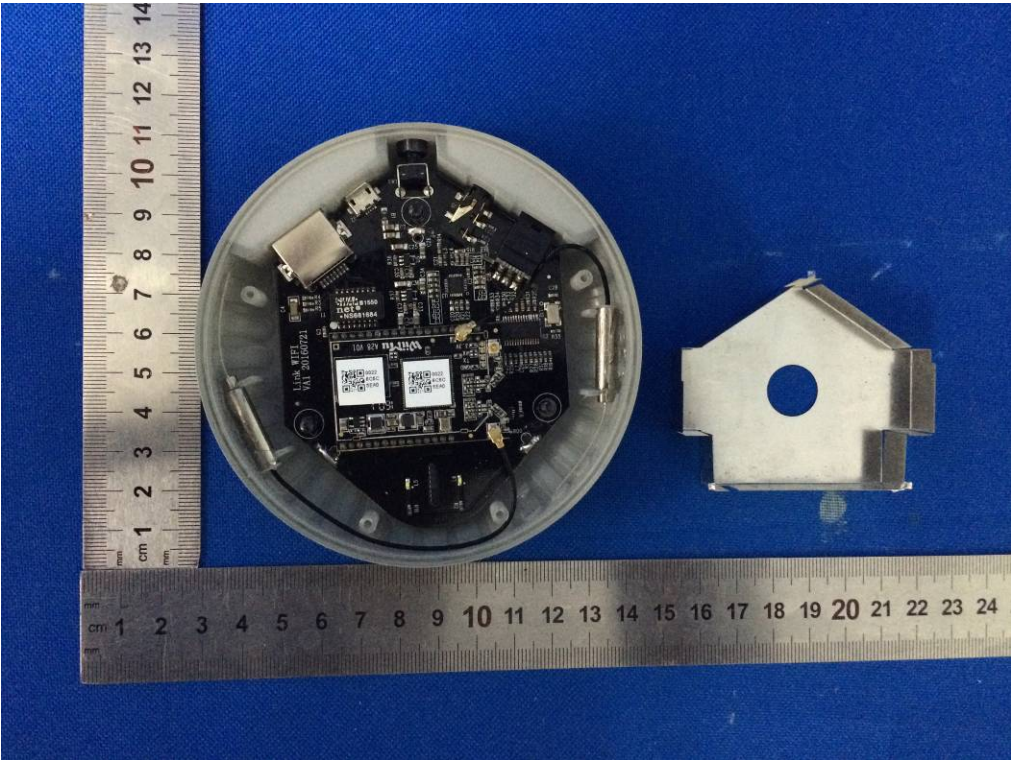
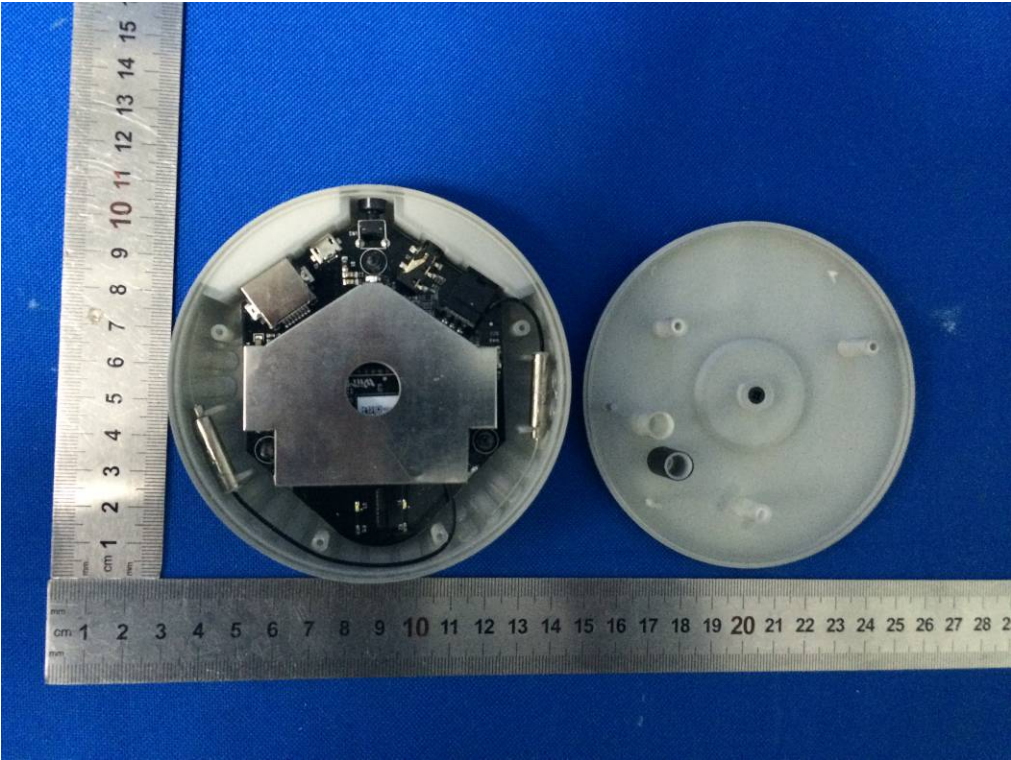

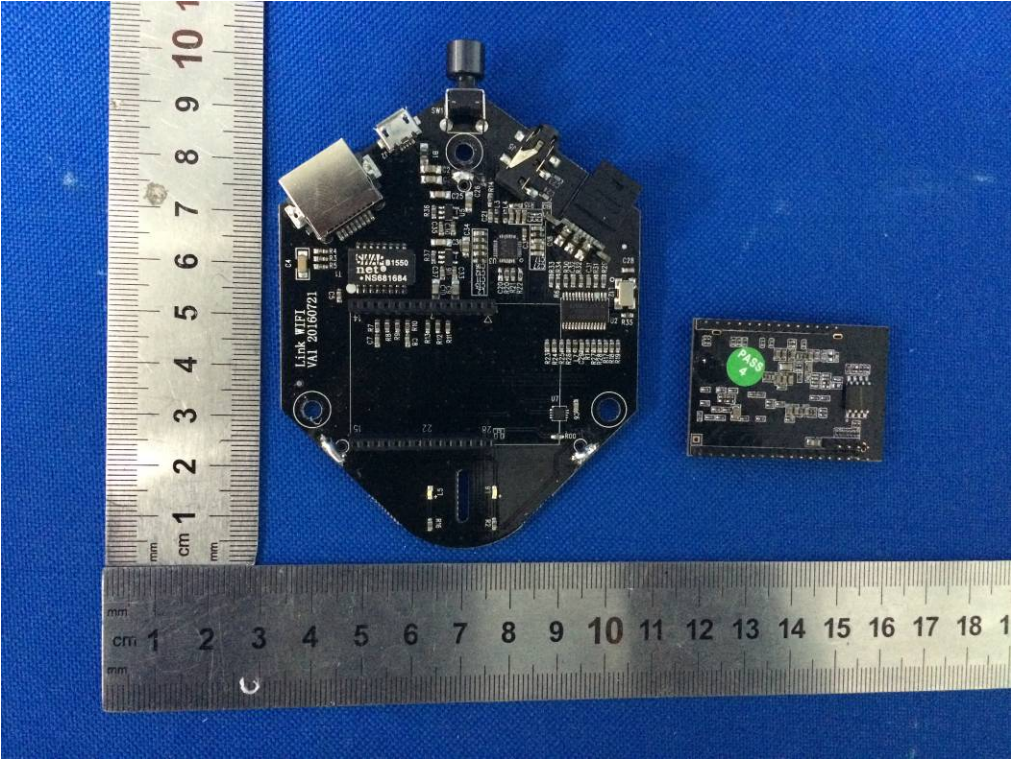
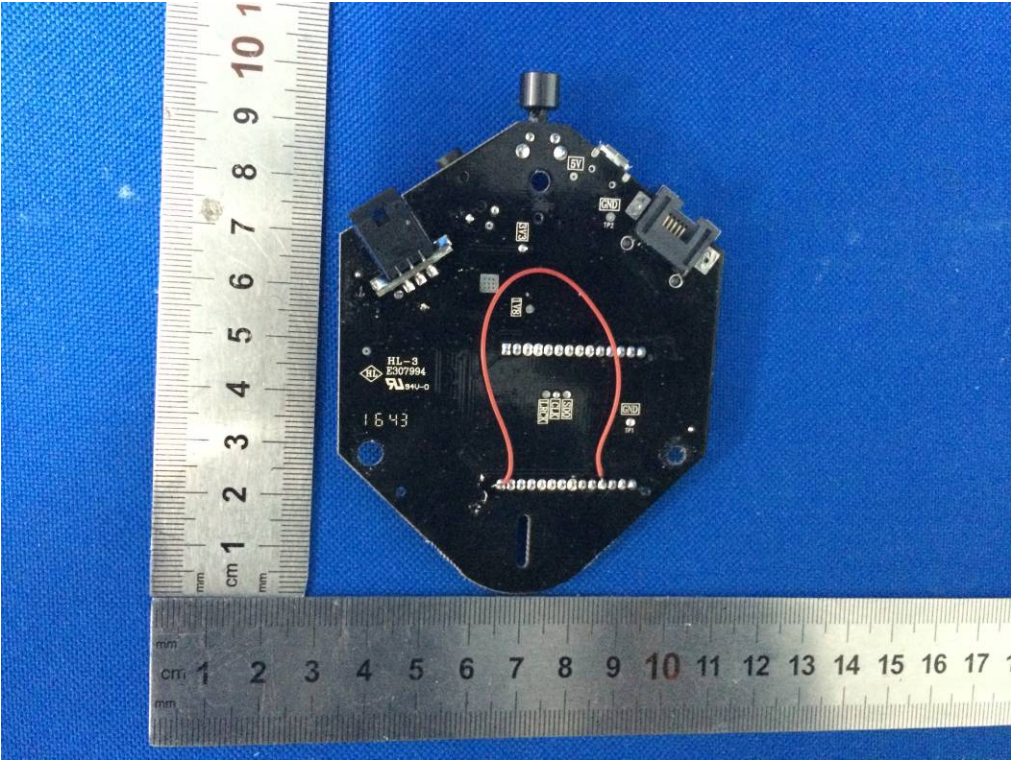

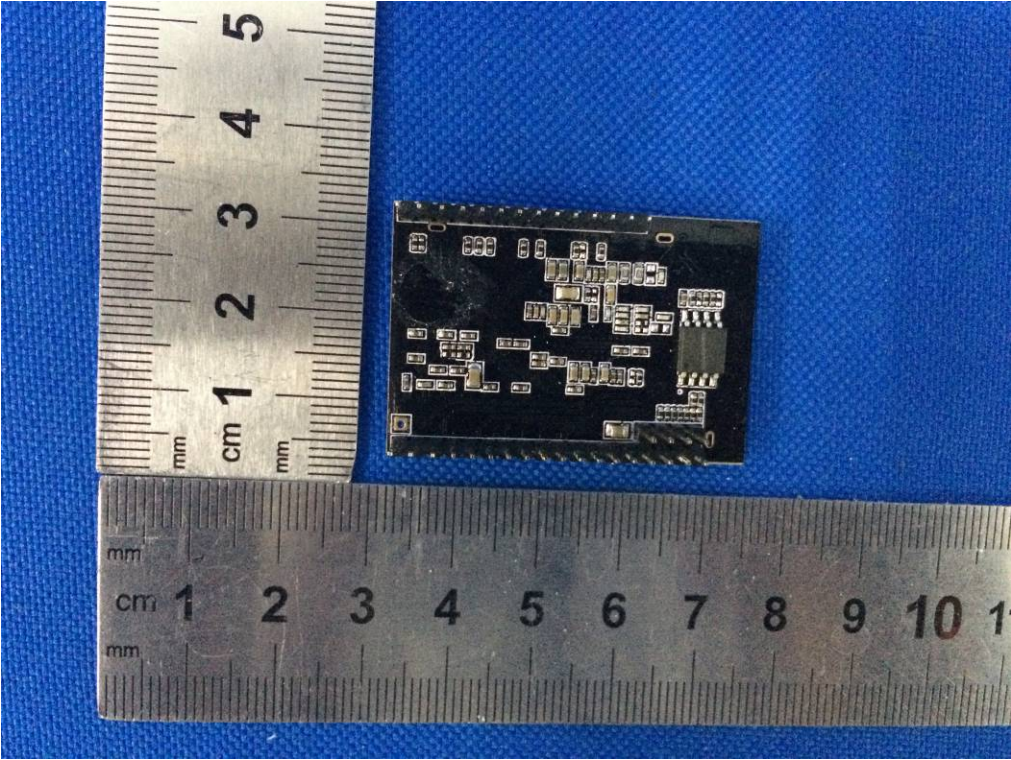
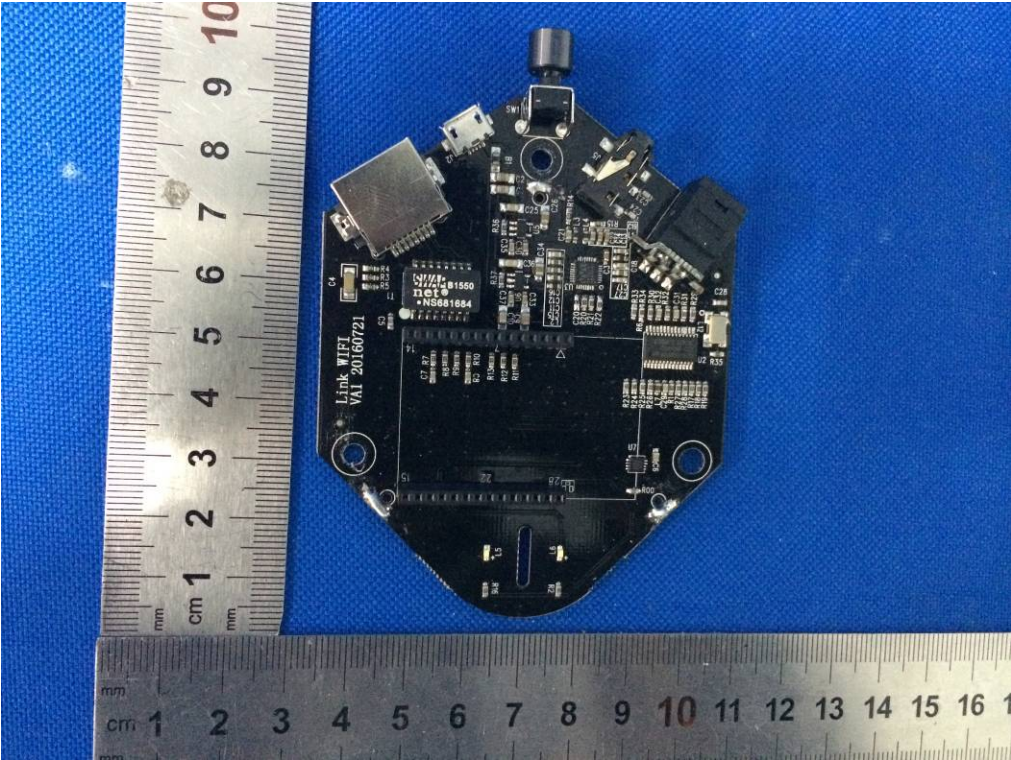

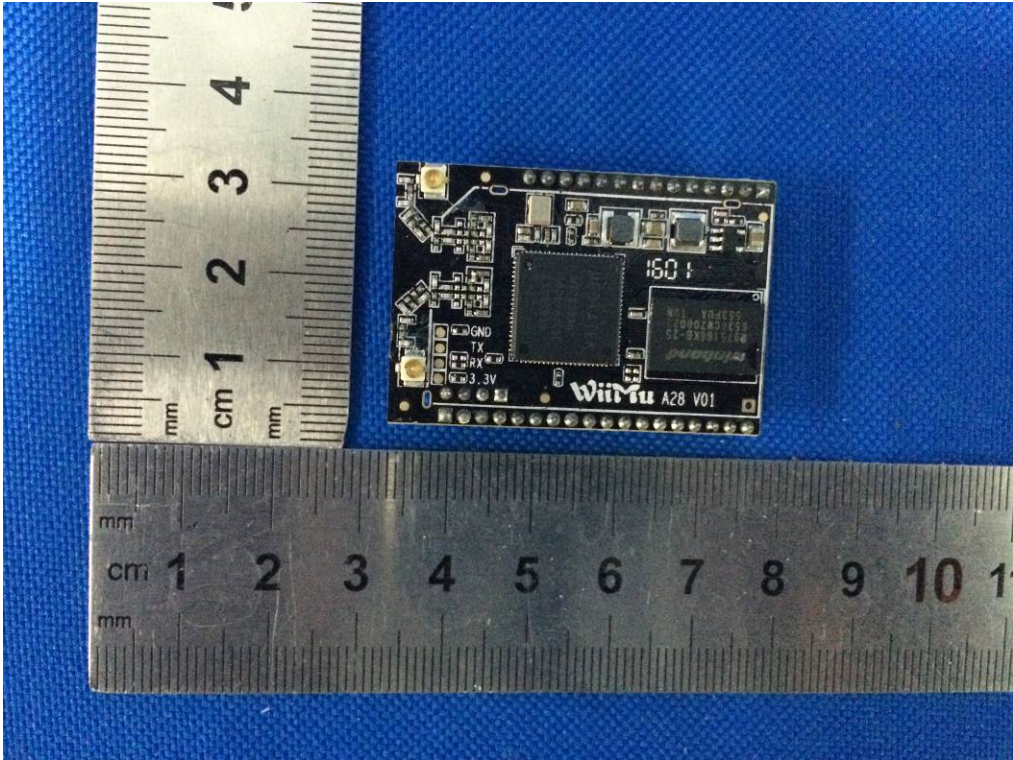

END OF REPORT