



RF TEST REPORT

Applicant Sengled Co., Ltd.
FCC ID 2AGN8-VM001
Product Sengled Z-wave Module
Brand sengled
Model VM001
Report No. R2104A0358-R1V2
Issue Date August 30, 2021

TA Technology (Shanghai) Co., Ltd. tested the above equipment in accordance with the requirements in **FCC CFR47 Part 15C (2020)**. The test results show that the equipment tested is capable of demonstrating compliance with the requirements as documented in this report.

Prepared by: Peng Tao

Approved by: Kai Xu

TA Technology (Shanghai) Co., Ltd.

No.145, Jintang Rd, Tangzhen Industry Park, Pudong Shanghai, China

TEL: +86-021-50791141/2/3

FAX: +86-021-50791141/2/3-8000



TABLE OF CONTENT

1. Test Laboratory	5
1.1. Notes of the test report.....	5
1.2. Test facility	5
1.3. Testing Location.....	5
2. General Description of Equipment under Test.....	6
2.1. Applicant and Manufacturer Information.....	6
2.2. General information.....	6
3. Applied Standards	7
4. Test Configuration	8
5. Test Case Results	9
5.1. Occupied Bandwidth (20dB).....	9
5.2. Unwanted Emission	11
5.3. Conducted Emission	19
6. Main Test Instruments.....	22
ANNEX A: The EUT Appearance	23
ANNEX B: Test Setup Photos	24



Version	Revision description	Issue Date
Rev.0	Initial issue of report.	June 9, 2021
Rev.1	Update data.	August 24, 2021
Rev.2	Update description	August 30, 2021

Note: This revised report (Report No. R2104A0358-R1V2) supersedes and replaces the previously issued report (Report No. R2104A0358-R1V1). Please discard or destroy the previously issued report and dispose of it accordingly.



Summary of measurement results

Number	Test Case	Clause in FCC rules	Verdict
1	Occupied Bandwidth (20dB)	15.249(a)	PASS
2	Unwanted Emissions	15.249(a),15.249(c),15.249(d),15.209,15.205;	PASS
3	Conducted Emissions	15.207;	PASS

Date of Testing: May 10, 2021 ~ August 2, 2021

Date of Sample Received: April 19, 2021

Note: PASS: The EUT complies with the essential requirements in the standard.

FAIL: The EUT does not comply with the essential requirements in the standard.

All indications of Pass/Fail in this report are opinions expressed by TA Technology (Shanghai) Co., Ltd. based on interpretations and/or observations of test results. Measurement Uncertainties were not taken into account and are published for informational purposes only.



1. Test Laboratory

1.1. Notes of the test report

This report shall not be reproduced in full or partial, without the written approval of **TA technology (shanghai) co., Ltd.** The results documented in this report apply only to the tested sample, under the conditions and modes of operation as described herein .Measurement Uncertainties were not taken into account and are published for informational purposes only. This report is written to support regulatory compliance of the applicable standards stated above.

1.2. Test facility

FCC (Designation number: CN1179, Test Firm Registration Number: 446626)

TA Technology (Shanghai) Co., Ltd. has been listed on the US Federal Communications Commission list of test facilities recognized to perform electromagnetic emissions measurements.

A2LA (Certificate Number: 3857.01)

TA Technology (Shanghai) Co., Ltd. has been listed by American Association for Laboratory Accreditation to perform electromagnetic emission measurement.

1.3. Testing Location

Company: TA Technology (Shanghai) Co., Ltd.
Address: No.145, Jintang Rd, Tangzhen Industry Park, Pudong
City: Shanghai
Post code: 201201
Country: P. R. China
Contact: Xu Kai
Telephone: +86-021-50791141/2/3
Fax: +86-021-50791141/2/3-8000
Website: <http://www.ta-shanghai.com>
E-mail: xukai@ta-shanghai.com

2. General Description of Equipment under Test

2.1. Applicant and Manufacturer Information

Applicant	Sengled Co., Ltd.
Applicant address	Room 103/02-B, Floor 1, Building 1, No.498, Guoshoujing Road, Pilot Free Trade Zone, Shanghai City, China
Manufacturer	Sengled Co., Ltd.
Manufacturer address	Room 103/02-B, Floor 1, Building 1, No.498, Guoshoujing Road, Pilot Free Trade Zone, Shanghai City, China

2.2. General information

EUT Description	
Model	VM001
Lab internal SN	R2104A0358/S01
HW Version	V1
SW Version	V2.15
Power Supply	External power supply
Antenna Type	Internal Antenna
Test Mode(s)	z-wave
Tested Frequency Range(s)	908.42 MHz
Modulation Type	FSK, GFSK
Note: The EUT is sent from the applicant to TA and the information of the EUT is declared by the applicant.	



3. Applied Standards

According to the specifications of the manufacturer, it must comply with the requirements of the following standards:

Test standards:

FCC CFR47 Part 15C (2020) Radio Frequency Devices

ANSI C63.10 (2013)

4. Test Configuration

Test Mode

The EUT has been associated with peripherals and configuration operated in a manner tended to maximize its emission characteristics in a typical application.

The radiated emission was measured in the following position: EUT stand-up position (Z axis), lie-down position (X, Y axis). The worst emission was found in lie-down position (X axis) and the worst case was recorded.

5. Test Case Results

5.1. Occupied Bandwidth (20dB)

Ambient condition

Temperature	Relative humidity	Pressure
23°C ~25°C	45%~50%	101.5kPa

Method of Measurement

The EUT was connected to the spectrum analyzer through an external attenuator (20dB) and a known loss cable. RBW is set to 100 kHz; VBW is set to 300 kHz on spectrum analyzer. Dector=Peak, Trace mode=max hold.

The EUT was connected to the spectrum analyzer through a known loss cable. The resolution bandwidth (RBW) shall be in the range of 1% to 5% of the actual occupied / x dB bandwidth and the video bandwidth (VBW) shall not be smaller than three times the RBW value.

Test Setup

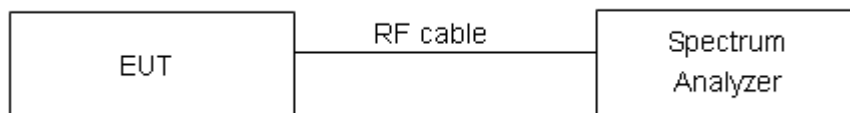

Measurement Uncertainty

The assessed measurement uncertainty to ensure 95% confidence level for the normal distribution is with the coverage factor $k = 2$, $U = 936$ Hz.

Test Results:

Test Mode	Carrier frequency (MHz)	99% bandwidth (kHz)	20 dB bandwidth (kHz)	Conclusion
z-wave	908.4	74.021	87.33	PASS

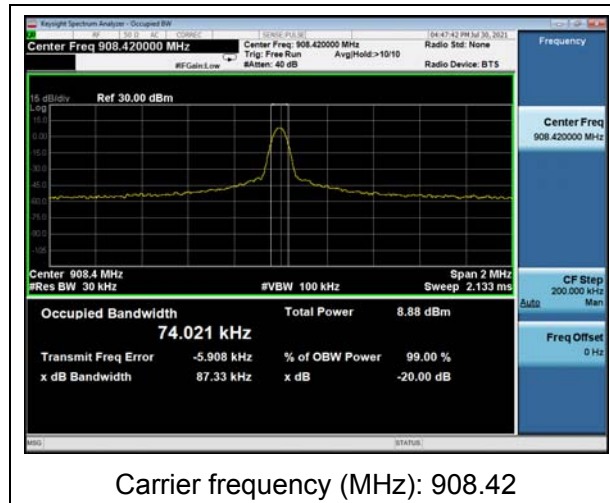

5.2. Unwanted Emission

Ambient condition

Temperature	Relative humidity	Pressure
23°C ~25°C	45%~50%	102.5kPa

Method of Measurement

The test set-up was made in accordance to the general provisions of ANSI C63.10.

The Equipment Under Test (EUT) was set up on a non-conductive table in the semi-anechoic chamber. The test was performed at the distance of 3 m between the EUT and the receiving antenna.

The turntable shall be rotated from 0 to 360 degrees for detecting the maximum of radiated spurious signal level. The measurements shall be repeated with orthogonal polarization of the test antenna. The data of cable loss and antenna factor has been calibrated in full testing frequency range before the testing. Sweep the Restricted Band and the emissions less than 20 dB below the permissible value are reported.

The radiated emissions measurements were made in a typical installation configuration.

Sweep the whole frequency band through the range from 9 kHz to the 10th harmonic of the carrier, and the emissions less than 20 dB below the permissible value are reported.

This method refer to ANSI C63.10.

The procedure for peak unwanted emissions measurements above 1000 MHz is as follows:

Set the spectrum analyzer in the following:

9kHz~150 kHz

RBW=200Hz, VBW=1kHz/ Sweep=AUTO

150 kHz~30MHz

RBW=9KHz, VBW=30KHz,/ Sweep=AUTO

Below 1GHz

RBW=100kHz / VBW=300kHz / Sweep=AUTO

a) Peak emission levels are measured by setting the instrument as follows:

Above 1GHz

PEAK: RBW=1MHz VBW=3MHz/ Sweep=AUTO

b) Average emission levels are measured by setting the instrument as follows:

Above 1GHz

AVERAGE: RBW=1MHz / VBW=3MHz / Sweep=AUTO

c) Detector: The measurements employing a CISPR quasi-peak detector except for the frequency bands 9-90 kHz, 110-490 kHz and above 1000 MHz. Radiated emission limits in these three bands are based on measurements employing an average detector.

d) Averaging type = power (i.e., rms) (As an alternative, the detector and averaging type may be set for linear voltage averaging. Some instruments require linear display mode to use linear voltage



averaging. Log or dB averaging shall not be used.)

e) Sweep time = auto.

f) Perform a trace average of at least 100 traces if the transmission is continuous. If the transmission is not continuous, then the number of traces shall be increased by a factor of $1 / D$, where D is the duty cycle. For example, with 50% duty cycle, at least 200 traces shall be averaged. (If a specific emission is demonstrated to be continuous—i.e., 100% duty cycle—then rather than turning ON and OFF with the transmit cycle, at least 100 traces shall be averaged.)

g) If tests are performed with the EUT transmitting at a duty cycle less than 98%, then a correction factor shall be added to the measurement results prior to comparing with the emission limit, to compute the emission level that would have been measured had the test been performed at 100% duty cycle. The correction factor is computed as follows:

1) If power averaging (rms) mode was used in the preceding step e), then the correction factor is $[10 \log (1 / D)]$, where D is the duty cycle. For example, if the transmit duty cycle was 50%, then 3 dB shall be added to the measured emission levels.

2) If linear voltage averaging mode was used in the preceding step e), then the correction factor is $[20 \log (1 / D)]$, where D is the duty cycle. For example, if the transmit duty cycle was 50%, then 6 dB shall be added to the measured emission levels.

3) If a specific emission is demonstrated to be continuous (100% duty cycle) rather than turning ON and OFF with the transmit cycle, then no duty cycle correction is required for that emission.

The test is in transmitting mode.

Test setup

9KHz ~ 30MHz

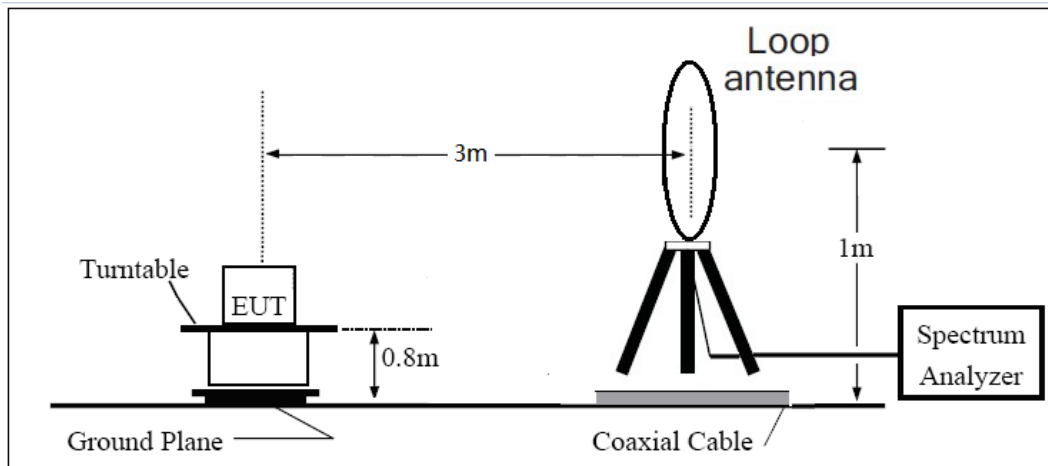

30MHz ~ 1GHz

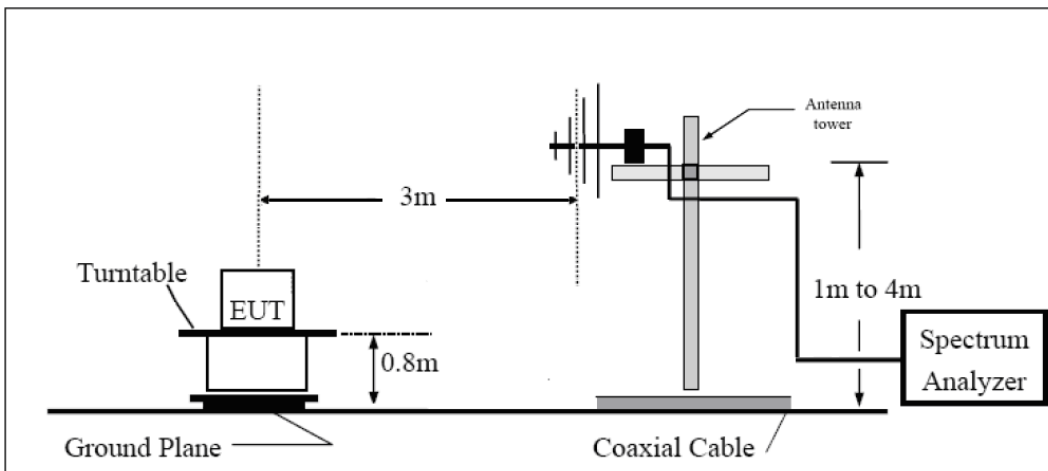

Above 1GHz

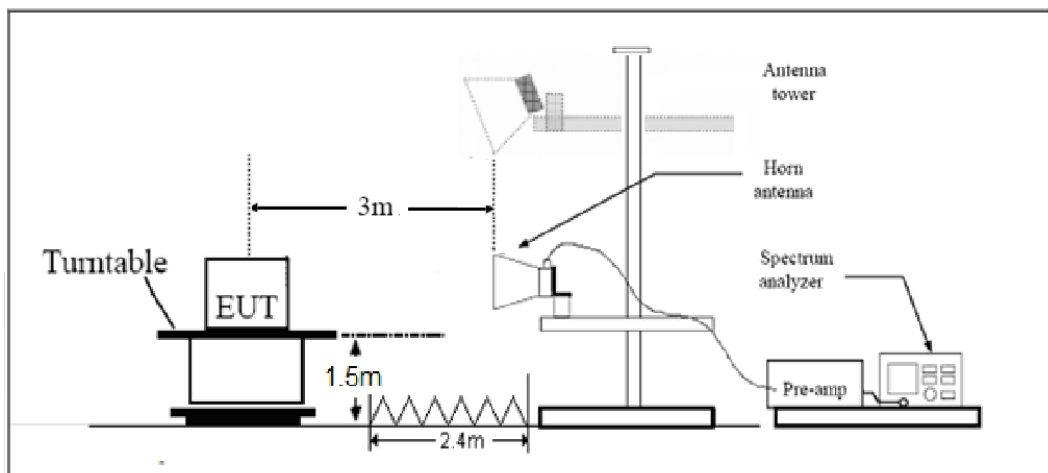

Note: Area side:2.4mX3.6m

Limits

Rule Part 15.247(d) specifies that “In addition, radiated emissions which fall in the restricted bands, as defined in § 15.205(a), must also comply with the radiated emission limits specified in § 15.209(a) (see § 15.205(c)).”

(a) the field strength of emissions from intentional radiators operated within these frequency bands shall comply with the following:

Fundamental frequency	Field strength of fundamental (millivolts/meter)	Field strength of harmonics (microvolts/meter)
902-928 MHz	50(93.9dBuV/m)	500(53.9dBuV/m)
2400-2483.5 MHz	50(93.9dBuV/m)	500(53.9dBuV/m)
5725-5875 MHz	50(93.9dBuV/m)	500(53.9dBuV/m)
24.0-24.25 GHz	250(107.9dBuV/m)	2500(67.9dBuV/m)

Limit in restricted band

Frequency of emission (MHz)	Field strength(uV/m)	Field strength(dBuV/m)
0.009–0.490	2400/F(kHz)	/
0.490–1.705	24000/F(kHz)	/
1.705–30.0	30	/
30-88	100	40
88-216	150	43.5
216-960	200	46
Above960	500	54

§15.35(b)

There is also a limit on the radio frequency emissions, as measured using instrumentation with a peak detector function, corresponding to 20 dB above the maximum permitted average limit.

Peak Limit=74 dBuV/m

Average Limit=54 dBuV/m

Spurious Radiated Emissions are permitted in any of the frequency bands listed below:



MHz	MHz	MHz	GHz
0.090 - 0.110	16.42 - 16.423	399.9 - 410	4.5 - 5.15
¹ 0.495 - 0.505	16.69475 - 16.69525	608 - 614	5.35 - 5.46
2.1735 - 2.1905	16.80425 - 16.80475	960 - 1240	7.25 - 7.75
4.125 - 4.128	25.5 - 25.67	1300 - 1427	8.025 - 8.5
4.17725 - 4.17775	37.5 - 38.25	1435 - 1626.5	9.0 - 9.2
4.20725 - 4.20775	73 - 74.6	1645.5 - 1646.5	9.3 - 9.5
6.215 - 6.218	74.8 - 75.2	1660 - 1710	10.6 - 12.7
6.26775 - 6.26825	108 - 121.94	1718.8 - 1722.2	13.25 - 13.4
6.31175 - 6.31225	123 - 138	2200 - 2300	14.47 - 14.5
8.291 - 8.294	149.9 - 150.05	2310 - 2390	15.35 - 16.2
8.362 - 8.366	156.52475 - 156.52525	2483.5 - 2500	17.7 - 21.4
8.37625 - 8.38675	156.7 - 156.9	2690 - 2900	22.01 - 23.12
8.41425 - 8.41475	162.0125 - 167.17	3260 - 3267	23.6 - 24.0
12.29 - 12.293	167.72 - 173.2	3332 - 3339	31.2 - 31.8
12.51975 - 12.52025	240 - 285	3345.8 - 3358	36.43 - 36.5
12.57675 - 12.57725	322 - 335.4	3600 - 4400	(²)
13.36 - 13.41			

Measurement Uncertainty

The assessed measurement uncertainty to ensure 95% confidence level for the normal distribution is with the coverage factor $k = 1.96$.

Frequency	Uncertainty
9KHz-30MHz	3.55 dB
30MHz-200MHz	4.17 dB
200MHz-1GHz	4.84 dB
1-18GHz	4.35 dB
18-26.5GHz	5.90 dB
26.5GHz~40GHz	5.92 dB

Test Results:

A font (Level in dB μ V/m) in the test plot =(level in dB μ V/m)

A font (Level in dB μ V) in the test plot =(level in dB μ V/m)

Fundamental Field Strength

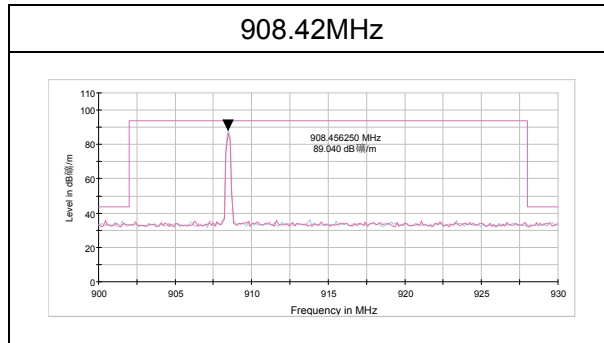

Band edge

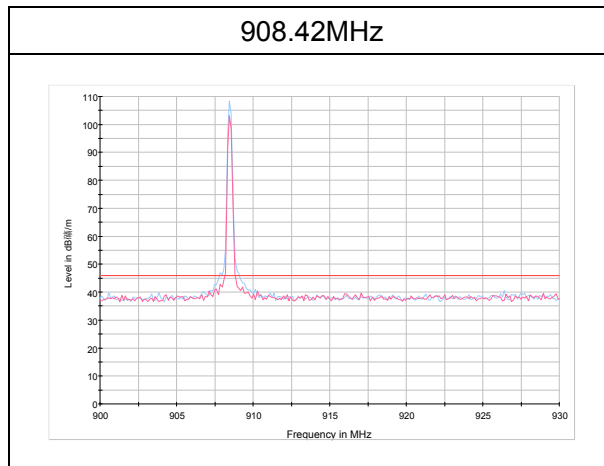

908.42MHz

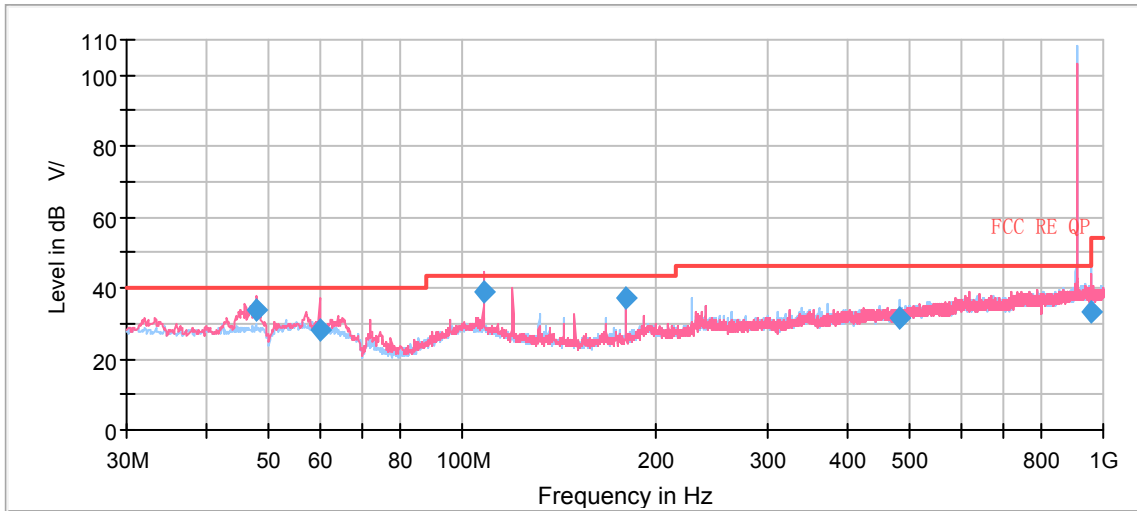

Note: The signal beyond the limit is carrier.

Radiated Emission 30M-1GHz

Frequency (MHz)	Quasi-Peak (dBuV/m)	Height (cm)	Polarization	Azimuth (deg)	Correct Factor (dB)	Margin (dB)	Limit (dBuV/m)
47.945000	34.10	101.0	V	251.0	4.9	5.90	40.00
59.948750	27.98	111.0	V	0.0	4.7	12.02	40.00
108.085000	39.11	101.0	V	63.0	4.1	4.39	43.50
180.107500	37.13	184.0	H	273.0	2.0	6.37	43.50
480.201250	31.74	100.0	H	352.0	9.9	14.26	46.00
960.593750	33.02	100.0	H	312.0	15.7	20.98	54.00

- Remark:**
1. Quasi-Peak = Reading value + Correction factor
 2. Correction Factor = Antenna factor+ Insertion loss(cable loss+amplifier gain)
 3. Margin = Limit – Quasi-Peak

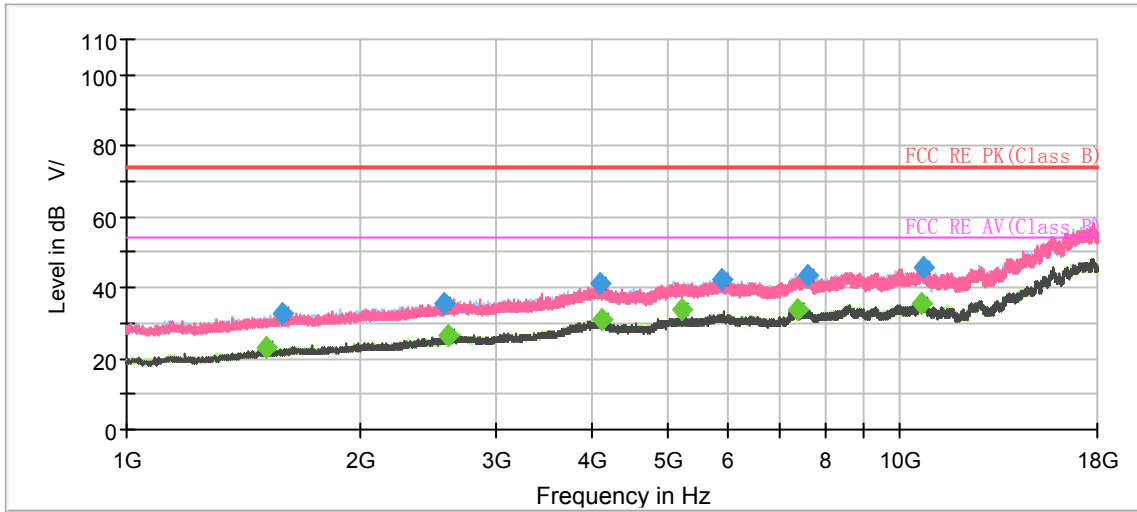

Radiated Emission 1G-18GHz

Frequency (MHz)	Peak (dBuV/m)	Average (dBuV/m)	Height (cm)	Polarization	Azimuth (deg)	Correct Factor (dB)	Margin (dB)	Limit (dBuV/m)
1519.633333	---	23.30	100.0	H	185.0	-15.5	30.70	54.00
1593.300000	32.49	---	200.0	H	132.0	-15.1	41.51	74.00
2570.233333	35.65	---	200.0	V	308.0	-10.2	38.35	74.00
2602.533333	---	26.78	200.0	H	241.0	-10.0	27.22	54.00
4097.400000	41.37	---	200.0	V	0.0	-3.2	32.63	74.00
4117.800000	---	30.89	200.0	V	127.0	-3.1	23.11	54.00
5210.900000	---	34.05	100.0	H	204.0	-1.2	19.95	54.00
5888.066667	42.24	---	200.0	V	344.0	-0.3	31.76	74.00
7354.600000	---	33.95	100.0	V	91.0	1.5	20.05	54.00
7576.733333	43.50	---	200.0	V	299.0	1.4	30.50	74.00
10650.33333	---	35.55	200.0	H	0.0	5.4	18.45	54.00

5.3. Conducted Emission

Ambient condition

Temperature	Relative humidity	Pressure
23°C ~25°C	45%~50%	101.5kPa

Methods of Measurement

The EUT is placed on a non-metallic table of 80cm height above the horizontal metal reference ground plane. During the test, the EUT was operating in its typical mode. The test method is according to ANSI C63.10. Connect the AC power line of the EUT to the L.I.S.N. Use EMI receiver to detect the average and Quasi-peak value. RBW is set to 9 kHz, VBW is set to 30kHz.

The measurement result should include both L line and N line.

The test is in transmitting mode.

Test Setup

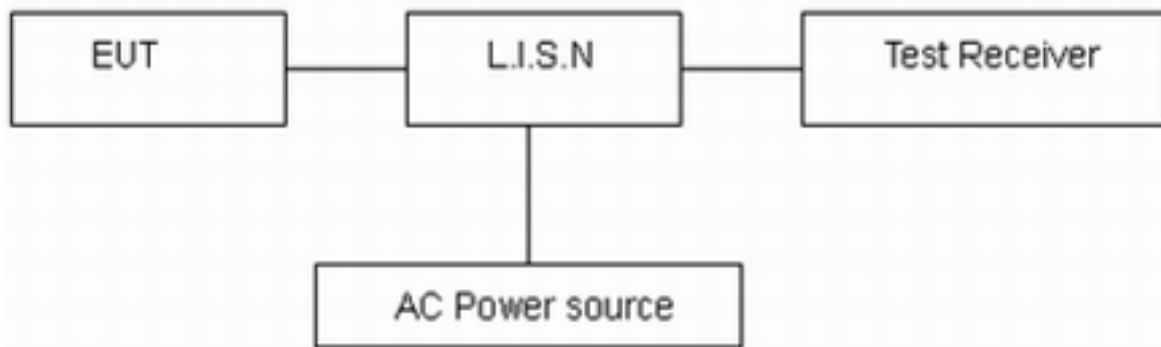

Note: AC Power source is used to change the voltage 110V/60Hz.

Limits

Frequency (MHz)	Conducted Limits(dBμV)	
	Quasi-peak	Average
0.15 - 0.5	66 to 56 *	56 to 46*
0.5 - 5	56	46
5 - 30	60	50

*: Decreases with the logarithm of the frequency.

Measurement Uncertainty

The assessed measurement uncertainty to ensure 95% confidence level for the normal distribution is with the coverage factor $k = 1.96$, $U = 2.69$ dB.

Test Results:

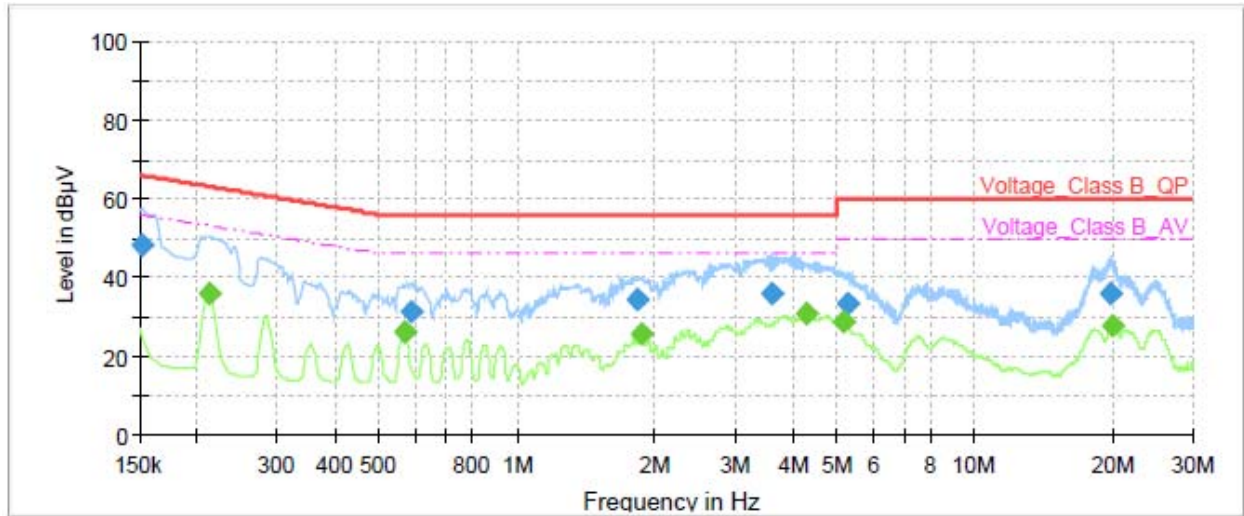

Frequency (MHz)	QuasiPeak (dBµV)	Average (dBµV)	Limit (dBµV)	Margin (dB)	Meas. Time (ms)	Bandwidth (kHz)	Line	Filter	Corr. (dB)
0.15	48.19	---	65.88	17.69	70.0	9.000	L1	ON	21
0.21	---	35.99	53.09	17.10	70.0	9.000	L1	ON	21
0.57	---	26.04	46.00	19.96	70.0	9.000	L1	ON	20
0.59	31.04	---	56.00	24.96	70.0	9.000	L1	ON	20
1.84	34.20	---	56.00	21.80	70.0	9.000	L1	ON	20
1.87	---	25.60	46.00	20.40	70.0	9.000	L1	ON	20
3.60	35.99	---	56.00	20.01	70.0	9.000	L1	ON	19
4.31	---	30.62	46.00	15.38	70.0	9.000	L1	ON	19
5.18	---	28.63	50.00	21.37	70.0	9.000	L1	ON	19
5.29	33.51	---	60.00	26.49	70.0	9.000	L1	ON	19
19.76	35.68	---	60.00	24.32	70.0	9.000	L1	ON	20
20.06	---	27.48	50.00	22.52	70.0	9.000	L1	ON	20

L line Conducted Emission from 150 KHz to 30 MHz

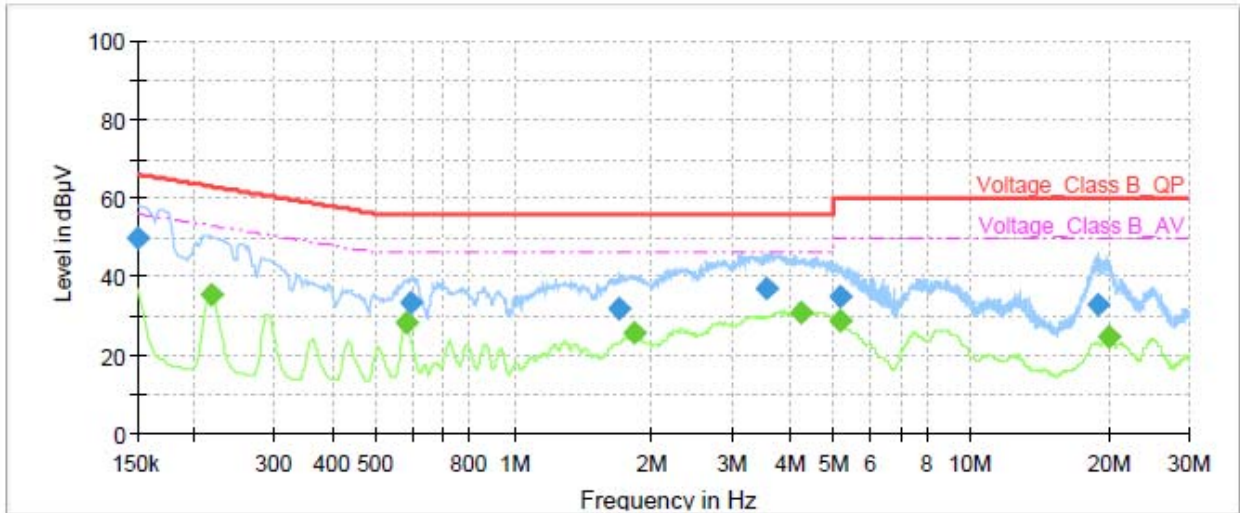

Frequency (MHz)	QuasiPeak (dBµV)	Average (dBµV)	Limit (dBµV)	Margin (dB)	Meas. Time (ms)	Bandwidth (kHz)	Line	Filter	Corr. (dB)
0.15	49.62	---	66.00	16.38	70.0	9.000	N	ON	21
0.22	---	35.51	52.91	17.40	70.0	9.000	N	ON	21
0.58	---	28.23	46.00	17.77	70.0	9.000	N	ON	20
0.59	33.46	---	56.00	22.54	70.0	9.000	N	ON	20
1.70	31.90	---	56.00	24.10	70.0	9.000	N	ON	20
1.82	---	25.57	46.00	20.43	70.0	9.000	N	ON	20
3.56	36.70	---	56.00	19.30	70.0	9.000	N	ON	19
4.26	---	30.80	46.00	15.20	70.0	9.000	N	ON	19
5.15	34.94	---	60.00	25.06	70.0	9.000	N	ON	19
5.19	---	28.63	50.00	21.37	70.0	9.000	N	ON	19
19.03	32.91	---	60.00	27.09	70.0	9.000	N	ON	20
19.98	---	24.71	50.00	25.29	70.0	9.000	N	ON	20

N line Conducted Emission from 150 KHz to 30 MHz



6. Main Test Instruments

Name	Manufacturer	Type	Serial Number	Calibration Date	Expiration Date
Spectrum Analyzer	R&S	FSV30	100815	2020-12-14	2021-12-13
EMI Test Receiver	R&S	ESCI	100948	2020-05-18	2021-05-17
			100936	2020-12-13	2021-12-13
Loop Antenna	SCHWARZBECK	FMZB1519	1519-047	2020-04-02	2023-04-01
TRILOG Broadband Antenna	SCHWARZBECK	VULB 9163	391	2019-12-16	2021-12-15
Horn Antenna	R&S	HF907	102723	2018-08-11	2021-08-10
Horn Antenna	ETS-Lindgren	3160-09	00102643	2018-06-20	2021-06-19
				2018-06-20	2023-06-19
EMI Test Receiver	R&S	ESR	101667	2020-05-18	2021-05-17
				2021-05-15	2022-05-14
LISN	R&S	ENV216	101171	2018-12-15	2021-12-14
Spectrum Analyzer	Agilent	N9010A	MY47191109	2020-05-18	2021-05-17
				2021-05-15	2022-05-14
Power Meter	R&S	NRP2	104306	2020-05-18	2021-05-17
				2021-05-15	2022-05-14
Power Sensor	R&S	NRP-Z21	104799	2020-05-18	2021-05-17
				2021-05-15	2022-05-14
20dB Attenuator	Star River Highlight	UCL-TS2S-20	18013001	2020-12-14	2021-12-13
RF Cable	Agilent	SMA 15cm	0001	2020-12-11	2021-06-10
				2021-06-09	2021-12-08
Software	R&S	EMC32	9.26.0	/	/

*****END OF REPORT *****



ANNEX A: The EUT Appearance

The EUT Appearance are submitted separately.



ANNEX B: Test Setup Photos

The Test Setup Photos are submitted separately.