

FCC/ISED

RF

TEST REPORT

ISSUED BY
Shenzhen BALUN Technology Co., Ltd.



FOR
WiFi/BT Combo Module

ISSUED TO
Dongguan Digital AV Technology Corp., Ltd.

2nd floor F2-S3 district, No.18 Haibin road, Wusha, Changan, Dongguan,
Guangdong



Tested by:

Cao Shaodong

(Engineer)

Date

Mar. 15, 2016

Approved by:

Wei Yanquan

(Chief Engineer)

Date

Mar. 15, 2016

Report No.: BL-SZ15C0294-603

EUT Type: WiFi/BT Combo Module

Model Name: WUS-AC13

Brand Name: OPPO

Test Standard: 47 CFR Part 15 Subpart C

RSS-Gen (Issue 4, November 2014)

RSS-247 (Issue 1, May 2015)

FCC ID: 2AGM4-WUS13

ISED Number: 20960-WUS13

Test conclusion: Pass

Test Date: Feb. 26, 2016 ~ Mar. 4, 2016

Date of Issue: Mar. 15, 2016

NOTE: This test report can be duplicated completely for the legal use with the approval of the applicant; it shall not be reproduced except in full, without the written approval of Shenzhen BALUN Technology Co., Ltd. BALUN Laboratory. Any objections should be raised within thirty days from the date of issue. To validate the report, please visit BALUN website.

Revision History

| <u>Version</u> | <u>Issue Date</u> | <u>Revisions Content</u> |
|----------------|----------------------|--------------------------|
| <u>Rev. 01</u> | <u>Mar. 15, 2016</u> | <u>Initial Issue</u> |

TABLE OF CONTENTS

| | | |
|-------|--|----|
| 1 | ADMINISTRATIVE DATA (GENERAL INFORMATION) | 5 |
| 1.1 | Identification of the Testing Laboratory | 5 |
| 1.2 | Identification of the Responsible Testing Location | 5 |
| 1.3 | Laboratory Condition | 5 |
| 1.4 | Announce | 5 |
| 2 | PRODUCT INFORMATION | 7 |
| 2.1 | Applicant..... | 7 |
| 2.2 | Manufacturer | 7 |
| 2.3 | Factory Information | 7 |
| 2.4 | General Description for Equipment under Test (EUT) | 7 |
| 2.5 | Ancillary Equipment..... | 7 |
| 2.6 | Technical Information | 8 |
| 2.7 | Additional Instructions | 10 |
| 3 | SUMMARY OF TEST RESULTS..... | 11 |
| 3.1 | Test Standards | 11 |
| 3.2 | Verdict | 11 |
| 4 | GENERAL TEST CONFIGURATIONS..... | 12 |
| 4.1 | Test Environments | 12 |
| 4.2 | Test Equipment List..... | 12 |
| 4.3 | Test Configurations | 13 |
| 4.4 | Test Combination | 13 |
| 4.5 | Description of Test Setup..... | 13 |
| 4.5.1 | For Antenna Port Test..... | 13 |
| 4.5.2 | For AC Power Supply Port Test | 14 |
| 4.5.3 | For Radiated Test (Below 30 MHz) | 14 |

| | | |
|-------|---|----|
| 4.5.4 | For Radiated Test (30 MHz-1 GHz) | 15 |
| 4.5.5 | For Radiated Test (Above 1 GHz)..... | 15 |
| 4.6 | Test Conditions | 16 |
| 5 | TEST ITEMS..... | 17 |
| 5.1 | Antenna Requirements..... | 17 |
| 5.1.1 | Standard Applicable | 17 |
| 5.1.2 | Antenna Anti-Replacement Construction | 17 |
| 5.1.3 | Antenna Gain | 18 |
| 5.2 | Output Power | 19 |
| 5.2.1 | Test Limit..... | 19 |
| 5.2.2 | Test Setup..... | 19 |
| 5.2.3 | Test Procedure..... | 19 |
| 5.2.4 | Test Result | 20 |
| 5.3 | 6dB Bandwidth | 21 |
| 5.3.1 | Limit..... | 21 |
| 5.3.2 | Test Setup..... | 21 |
| 5.3.3 | Test Procedure..... | 21 |
| 5.3.4 | Test Result | 21 |
| 5.4 | Conducted Spurious Emission | 22 |
| 5.4.1 | Limit..... | 22 |
| 5.4.2 | Test Setup..... | 22 |
| 5.4.3 | Test Procedure..... | 22 |
| 5.4.4 | Test Result | 23 |
| 5.5 | Band Edge (Authorized-band band-edge)..... | 24 |
| 5.5.1 | Limit..... | 24 |
| 5.5.2 | Test Setup..... | 24 |
| 5.5.3 | Test Procedure..... | 24 |
| 5.5.4 | Test Result | 25 |
| 5.6 | Conducted Emission | 26 |
| 5.6.1 | Limit..... | 26 |
| 5.6.2 | Test Setup..... | 26 |

| | | |
|---------|--|----|
| 5.6.3 | Test Procedure | 26 |
| 5.6.4 | Test Result | 26 |
| 5.7 | Radiated Spurious Emission | 27 |
| 5.7.1 | Limit..... | 27 |
| 5.7.2 | Test Setup | 27 |
| 5.7.3 | Test Procedure | 27 |
| 5.7.4 | Test Result | 30 |
| 5.8 | Power Spectral density (PSD)..... | 31 |
| 5.8.1 | Limit..... | 31 |
| 5.8.2 | Test Setup | 31 |
| 5.8.3 | Test Procedure | 31 |
| 5.8.4 | Test Result | 31 |
| 5.9 | Receiver Spurious Emissions..... | 32 |
| 5.9.1 | Limit..... | 32 |
| 5.9.2 | Test Setup | 32 |
| 5.9.3 | Test Procedure | 32 |
| 5.9.4 | Test Result | 32 |
| ANNEX A | TEST RESULT | 33 |
| A.1 | Output Power | 33 |
| A.2 | Bandwidth..... | 35 |
| A.3 | Conducted Spurious Emissions | 41 |
| A.4 | Band Edge (Authorized-band band-edge)..... | 59 |
| A.5 | Conducted Emissions..... | 73 |
| A.6 | Radiated Emission | 75 |
| A.7 | Power Spectral Density (PSD) | 87 |
| A.8 | Receiver Spurious Emissions..... | 92 |
| ANNEX B | TEST SETUP PHOTOS | 96 |
| ANNEX C | EUT EXTERNAL PHOTOS | 96 |
| ANNEX D | EUT INTERNAL PHOTOS | 96 |

1 ADMINISTRATIVE DATA (GENERAL INFORMATION)

1.1 Identification of the Testing Laboratory

| | |
|--------------|---|
| Company Name | Shenzhen BALUN Technology Co., Ltd. |
| Address | Block B, 1st FL, Baisha Science and Technology Park, Shahe Xi Road, Nanshan District, Shenzhen, Guangdong Province, P. R. China |
| Phone Number | +86 755 6685 0100 |
| Fax Number | +86 755 6182 4271 |

1.2 Identification of the Responsible Testing Location

| | |
|---------------------------|---|
| Test Location | Shenzhen BALUN Technology Co., Ltd. |
| Address | Block B, 1st FL, Baisha Science and Technology Park, Shahe Xi Road, Nanshan District, Shenzhen, Guangdong Province, P. R. China |
| Accreditation Certificate | <p>The laboratory has been listed by Industry Canada to perform electromagnetic emission measurements. The recognition numbers of test site are 11524A-1.</p> <p>The laboratory has been listed by US Federal Communications Commission to perform electromagnetic emission measurements. The recognition numbers of test site are 832625.</p> <p>The laboratory is a testing organization accredited by China National Accreditation Service for Conformity Assessment (CNAS) according to ISO/IEC 17025. The accreditation certificate number is L6791.</p> |
| Description | All measurement facilities used to collect the measurement data are located at Block B, FL 1, Baisha Science and Technology Park, Shahe Xi Road, Nanshan District, Shenzhen, Guangdong Province, P. R. China 518055 |

1.3 Laboratory Condition

| | |
|---------------------------|-------------------|
| Ambient Temperature | 20 to 25°C |
| Ambient Relative Humidity | 45% - 55% |
| Ambient Pressure | 100 kPa - 102 kPa |

1.4 Announce

- (1) The test report reference to the report template version v2.1.
- (2) The test report is invalid if not marked with the signatures of the persons responsible for preparing and approving the test report.
- (3) The test report is invalid if there is any evidence and/or falsification.
- (4) The results documented in this report apply only to the tested sample, under the conditions and modes of operation as described herein.
- (5) This document may not be altered or revised in any way unless done so by BALUN and all revisions are duly noted in the revisions section.

- (6) Content of the test report, in part or in full, cannot be used for publicity and/or promotional purposes without prior written approval from the laboratory.

2 PRODUCT INFORMATION

2.1 Applicant

| | |
|-----------|--|
| Applicant | Dongguan Digital AV Technology Corp., Ltd. |
| Address | 2nd floor F2-S3 district, No.18 Haibin road, Wusha, Changan, Dongguan, Guangdong |

2.2 Manufacturer

| | |
|--------------|--|
| Manufacturer | Dongguan Digital AV Technology Corp., Ltd. |
| Address | 2nd floor F2-S3 district, No.18 Haibin road, Wusha, Changan, Dongguan, Guangdong |

2.3 Factory Information

| | |
|---------|--|
| Factory | Dongguan Digital AV Technology Corp., Ltd. |
| Address | 2nd floor F2-S3 district, No.18 Haibin road, Wusha, Changan, Dongguan, Guangdong |

2.4 General Description for Equipment under Test (EUT)

| | |
|-----------------------------------|--|
| EUT Type | WiFi/BT Combo Module |
| Model Name Under Test | WUS-AC13 |
| Hardware Version | A1 |
| Software Version | N/A |
| Network and Wireless connectivity | Bluetooth 3.0, Bluetooth 4.0 Low Energy (BLE) WIFI 802.11a, 802.11b, 802.11g, 802.11n(HT20/40) and 802.11ac |

2.5 Ancillary Equipment

N/A

2.6 Technical Information

The requirement for the following technical information of the EUT was tested in this report:

| | | |
|---|---|---|
| TX/ RX Operating Range | | 802.11b/g/n(20 MHz): 2.412 GHz - 2.462 GHz $f_c = 2412 \text{ MHz} + (N-1)*5 \text{ MHz}$, where - f_c = "Operating Frequency" in MHz, - N = "Channel Number" with the range from 1 to 11. 802.11n(40 MHz): 2.422 GHz - 2.452 GHz $f_c = 2412 \text{ MHz} + (N-1)*5 \text{ MHz}$, where - f_c = "Operating Frequency" in MHz, - N = "Channel Number" with the range from 3 to 9. |
| Modulation Type | | DSSS, OFDM |
| Product Type | | Indoor |
| Antenna System (eg., MIMO, Smart Antenna) | | Cyclic Delay Diversity (CDD) for 802.11n Unequal antenna gains, with equal transmit powers for 802.11b/g |
| Categorization as Correlated or Completely Uncorrelated | | Correlated |
| Antenna Type | Antenna 0 (ANT 0) | PCB Antenna |
| | Antenna 1 (ANT 1) | |
| Antenna Gain | Antenna 0 (ANT 0) | 3.5 dBi |
| | Antenna 1 (ANT 1) | 5.4 dBi |
| Total directional gain for 802.11n | For power spectral density(PSD) measurements | 5.4 Formulas: Directional gain = $G_{ANT} + \text{Array Gain}$, $\text{Array Gain} = 10 \log(N_{ANT}/N_{SS}) \text{ dB}$. $N_{SS} = 2$, G_{ANT} set equal to the gain of the antenna having the highest gain. |
| | For power measurements | 5.4 Formulas: Directional gain = $G_{ANT} + \text{Array Gain}$, $\text{Array Gain} = 0$. |
| | For Conducted Out-of-Band and Spurious Measurements | 5.4 Formulas: Directional gain = $G_{ANT} + \text{Array Gain}$, $\text{Array Gain} = 10 \log(N_{ANT}/N_{SS}) \text{ dB}$. $N_{SS} = 2$, G_{ANT} set equal to the gain of the antenna having the highest gain. |
| Total directional gain for 802.11b/g | For power spectral density(PSD) measurements | 7.5 Formulas: Directional gain = $10 \log[(10^{G1/20} + 10^{G2/20} + \dots + 10^{GN/20})^2 / N_{ANT}] \text{ dBi}$ |
| | For power measurements | 7.5 Formulas: Directional gain = $10 \log[(10^{G1/20} + 10^{G2/20} + \dots + 10^{GN/20})^2 / N_{ANT}] \text{ dBi}$ |
| | For Conducted Out-of-Band and Spurious Measurements | 7.5 Formulas: Directional gain = $10 \log[(10^{G1/20} + 10^{G2/20} + \dots + 10^{GN/20})^2 / N_{ANT}] \text{ dBi}$ |

| Modulation technology | Modulation Type | Transfer Rate (Mbps) | The Frequency Equal to the Transmission Rate of Modulation Signal |
|-----------------------|-----------------|----------------------|---|
| DSSS (802.11b) | DBPSK | 1 | 1 MHz |
| | DQPSK | 2 | |
| | CCK | 5.5/ 11 | 1.375 MHz |
| OFDM (802.11g) | BPSK | 6 / 9 | 1 MHz |
| | QPSK | 12 / 18 | |
| | 16QAM | 24 / 36 | |
| | 64QAM | 48 / 54 | |
| OFDM (802.11n-20MHz) | BPSK | 6.5 | 1 MHz |
| | QPSK | 13/19.5 | |
| | 16QAM | 26/39 | |
| | 64QAM | 52/58.5/65 | |
| OFDM (802.11n-40MHz) | BPSK | 13.5 | 1 MHz |
| | QPSK | 27/40.5 | |
| | 16QAM | 54/81/108 | |
| | 64QAM | 121.5/135 | |

Note: Preliminary tests were performed in different data rate in above table to find the worst radiated emission. The data rate shown in the table below is the worst-case rate with respect to the specific test item. Investigation has been done on all the possible configurations for searching the worst cases. The following table is a list of the test modes shown in this test report.

| Test Items | Mode | Data Rate | Channel | |
|------------------------------|---------------------|-------------------|---------|-------|
| Output Power | 11b/11g/11n20/11n40 | 1/6/6.5/13.5 Mbps | 1/6/11 | 3/6/9 |
| 6dB Bandwidth | 11b/11g/11n20/11n40 | 1/6/6.5/13.5 Mbps | 1/6/11 | 3/6/9 |
| Conducted Spurious Emission | 11b/11g/11n20/11n40 | 1/6/6.5/13.5 Mbps | 1/6/11 | 3/6/9 |
| Conducted Emission | 11b/11g/11n20/11n40 | 1/6/6.5/13.5 Mbps | 1/6/11 | 3/6/9 |
| Radiated Spurious Emission | 11b/11g/11n20/11n40 | 1/6/6.5/13.5 Mbps | 1/6/11 | 3/6/9 |
| Band Edge | 11b/11g/11n20/11n40 | 1/6/6.5/13.5 Mbps | 1/6/11 | 3/6/9 |
| Power spectral density (PSD) | 11b/11g/11n20/11n40 | 1/6/6.5/13.5 Mbps | 1/6/11 | 3/6/9 |

Note: The above EUT information in section 2.3 and 2.4 was declared by manufacturer and for more detailed features description, please refer to the manufacturer's specifications or user's manual.

2.7 Additional Instructions

| | |
|------|--|
| Mode | <input checked="" type="checkbox"/> Special software is used. The software provided by client to enable the EUT under transmission condition continuously at specific channel frequencies individually. |
|------|--|

During testing. Channel and Power Controlling Software provided by the customer was used to control the operating channel as well as the output power level. The RF output power selection is for the setting of RF output power expected by the customer and is going to be fixed on the firmware of the final end product.

EUT Software Settings:

| Power level setup in software | | | | |
|-------------------------------|----------|--------------------|----------|----|
| Test Version | Software | MT7662 QA V1.0.2.8 | | |
| Mode | Channel | Frequency (MHz) | Soft Set | |
| 11b | CH1 | 2412 | 1e | 1e |
| 11b | CH6 | 2437 | 1e | 1e |
| 11b | CH11 | 2462 | 1e | 1e |
| 11g | CH1 | 2412 | 1c | 1c |
| 11g | CH6 | 2437 | 20 | 20 |
| 11g | CH11 | 2462 | 20 | 20 |
| 11n (HT20) | CH1 | 2412 | 1a | 1a |
| 11n (HT20) | CH6 | 2437 | 20 | 20 |
| 11n (HT20) | CH11 | 2462 | 20 | 20 |
| 11n (HT40) | CH3 | 2422 | 20 | 20 |
| 11n (HT40) | CH6 | 2437 | 20 | 20 |
| 11n (HT40) | CH9 | 2452 | 20 | 20 |

Run Software

The screenshot shows the MT7662 QA V1.0.2.8 software interface. Key settings include:

- MAC Address:** 542AA2F7C16E
- Radio On/Off:** On
- RF Type:** MT7662 :: 2 T 2 R
- Channel:** 2412-MHz
- Mode:** CCK
- Rate:** MCS=0, LP 1 Mbps
- System BW:** 20
- Per-Pkt:** 20
- Primary Sel:** TX
- TX Frame Type:** Data
- TX Frame Setting:**
 - FC: 0800, Dur: 0000, Address1: FFFFFFFF, Address2: 542AA2F7C16E, Address3: 000A40AA5BCC, Seq: 0000
 - Repeat: AA, SW CRC Check: [checked], Total: 1058
- TX Power:** TX Power0 (0.5dB): 18, TX Power1 (0.5dB): 18
- RX Error (Dropped):** PCS error: 0/0, RX overflow: 0/0, PHY error: 0/0, False CCA: 0/0
- RX Okay:** U2M DATA: 0/0, Other DATA: 0/0, Beacon: 0/0, Others (Mgmt/Cntl): 0/0, FER: 0%
- RSSI tune:** RSSI1 = xx dBm Offset: 00, RSSI0 = xx dBm Offset: 00

3 SUMMARY OF TEST RESULTS

3.1 Test Standards

| No. | Identity | Document Title |
|-----|---|--|
| 1 | 47 CFR Part 15, Subpart C (10-1-14 Edition) | Miscellaneous Wireless Communications Services |
| 2 | KDB Publication 662911 D01 v02r01 | Emission Testing of Transmitters with Multiple Outputs in the same Band(e.g., MIMO, Smart Antenna, etc) |
| 3 | RSS-Gen (Issue 4, Nov. 2014) | General Requirements for Compliance of Radio Apparatus |
| 4 | RSS-247 (Issue 1, May 2015) | Digital Transmission Systems (DTSS), Frequency Hopping Systems(FHSs) and Licence-Exemp Local Area Network (LE-LAN) Devices |
| 5 | ANSI C63.4-2014 | American National Standard for Standard for Methods of Measurement of Radio-Noise Emissions from Low-Voltage Electrical and Electronic Equipment in the Range of 9 kHz to 40 GHz |
| 6 | ANSI C63.10-2013 | American National Standard for Testing Unlicensed Wireless Devices |

3.2 Verdict

| No. | Description | Part No. | Test Result | Verdict |
|-------------------------------------|------------------------------|---|-------------|---------|
| 1 | Antenna Requirement | RSS-247, 5.4 (6); 15.203; 15.247(b) | Note1 | Pass |
| 2 | Output Power | RSS-247, 5.4 (4); 15.247(b) | ANNEX A.1 | Pass |
| 3 | 6dB Bandwidth | RSS-GEN, 6.6; RSS-247, 5.2 (1); 15.247(a) | ANNEX A.2 | Pass |
| 4 | Conducted Spurious Emission | RSS-247, 5.5; 15.247(d) | ANNEX A.3 | Pass |
| 5 | Band Edge | RSS-247, 5.5; 15.247(d) | ANNEX A.4 | Pass |
| 6 | Conducted Emission | RSS-GEN, 8.8; 15.207 | ANNEX A.5 | Pass |
| 7 | Radiated Spurious Emission | RSS-247, 5.5; 15.209; 15.247(d) | ANNEX A.6 | Pass |
| 8 | Power spectral density (PSD) | RSS-247, 5.2 (2); 15.247(e) | ANNEX A.7 | Pass |
| 10 | Receiver Spurious Emissions | RSS-Gen, 7.1.2 | ANNEX A.8 | Pass |
| Note 1: Please refer to section 5.1 | | | | |

4 GENERAL TEST CONFIGURATIONS

4.1 Test Environments

During the measurement, the normal environmental conditions were within the listed ranges:

| | | |
|----------------------------|-------------------------|----------------|
| Relative Humidity | 45% - 55% | |
| Atmospheric Pressure | 100 kPa - 102 kPa | |
| Temperature | NT (Normal Temperature) | +22°C to +25°C |
| Working Voltage of the EUT | NV (Normal Voltage) | 3.3 V |

4.2 Test Equipment List

| Description | Manufacturer | Model | Serial No. | Cal. Date | Cal. Due |
|-----------------------------------|----------------------|------------|------------|------------|------------|
| Spectrum Analyzer | ROHDE&SCHWARZ | FSV-30 | 103118 | 2015.07.16 | 2016.07.15 |
| Vector Signal Generator | ROHDE&SCHWARZ | SMBV100A | 177746 | 2015.07.16 | 2016.07.15 |
| Signal Generator | ROHDE&SCHWARZ | SMB100A | 260592 | 2015.07.01 | 2016.06.30 |
| Switch Unit with OSP-B157 | ROHDE&SCHWARZ | OSP120 | 101270 | 2015.07.16 | 2016.07.15 |
| Spectrum Analyzer | AGILENT | E4440A | MY45304434 | 2015.10.18 | 2016.10.17 |
| EMI Receiver | ROHDE&SCHWARZ | ESRP | 101036 | 2015.07.14 | 2016.07.13 |
| LISN | SCHWARZBECK | NSLK 8127 | 8127-687 | 2015.07.14 | 2016.07.13 |
| Bluetooth Tester | ROHDE&SCHWARZ | CBT | 101005 | 2015.07.16 | 2016.07.15 |
| Power Splitter | KMW | DCPD-LDC | 1305003215 | 2015.07.01 | 2016.06.30 |
| Power Sensor | ROHDE&SCHWARZ | NRP-Z21 | 103971 | 2015.07.21 | 2016.07.20 |
| Attenuator (20 dB) | KMW | ZA-S1-201 | 110617091 | -- | -- |
| Attenuator (6 dB) | KMW | ZA-S1-61 | 1305003189 | -- | -- |
| DC Power Supply | ROHDE&SCHWARZ | HMP2020 | 018141664 | 2015.07.17 | 2016.07.16 |
| Temperature Chamber | ANGELANTIONI SCIENCE | NTH64-40A | 1310 | 2015.08.07 | 2016.08.06 |
| Test Antenna-Loop(9 kHz-30 MHz) | SCHWARZBECK | FMZB 1519 | 1519-037 | 2015.07.22 | 2017.07.21 |
| Test Antenna-Bi-Log(30 MHz-3 GHz) | SCHWARZBECK | VULB 9163 | 9163-624 | 2015.07.22 | 2017.07.21 |
| Test Antenna-Horn(1-18 GHz) | SCHWARZBECK | BBHA 9120D | 9120D-1148 | 2015.07.22 | 2017.07.21 |
| Test Antenna-Horn(15-26.5 GHz) | SCHWARZBECK | BBHA 9170 | 9170-305 | 2015.07.22 | 2017.07.21 |
| Anechoic Chamber | RAINFORD | 9m*6m*6m | N/A | 2015.02.28 | 2017.02.27 |
| Shielded Enclosure | ChangNing | CN-130701 | 130703 | -- | -- |

4.3 Test Configurations

| Test Configurations (TC) NO. | Description | |
|------------------------------|----------------------------------|---------------------|
| | Signal Description | Operating Frequency |
| Transmitter | | |
| TC01 | DSSS modulation, 802.11b | Ch No. 1/ 2412 MHz |
| TC02 | DSSS modulation, 802.11b | Ch No. 6/ 2437 MHz |
| TC03 | DSSS modulation, 802.11b | Ch No. 11/ 2462 MHz |
| TC04 | OFDM modulation, 802.11g | Ch No. 1/ 2412 MHz |
| TC05 | OFDM modulation, 802.11g | Ch No. 6/ 2437 MHz |
| TC06 | OFDM modulation, 802.11g | Ch No. 11/ 2462 MHz |
| TC07 | OFDM modulation, 802.11n(20 MHz) | Ch No. 1/ 2412 MHz |
| TC08 | OFDM modulation, 802.11n(20 MHz) | Ch No. 6/ 2437 MHz |
| TC09 | OFDM modulation, 802.11n(20 MHz) | Ch No. 11/ 2462 MHz |
| TC10 | OFDM modulation, 802.11n(40 MHz) | Ch No. 3/ 2422 MHz |
| TC11 | OFDM modulation, 802.11n(40 MHz) | Ch No. 6/ 2437 MHz |
| TC12 | OFDM modulation, 802.11n(40 MHz) | Ch No. 9/ 2452 MHz |

4.4 Test Combination

| | Antenna 0 | Antenna 1 | Antenna 0 & Antenna 1 |
|--------|-----------|-----------|-----------------------|
| CASE 1 | √ | √ | |
| CASE 2 | √ | √ | |
| CASE 3 | | | √ |

4.5 Description of Test Setup

4.5.1 For Antenna Port Test

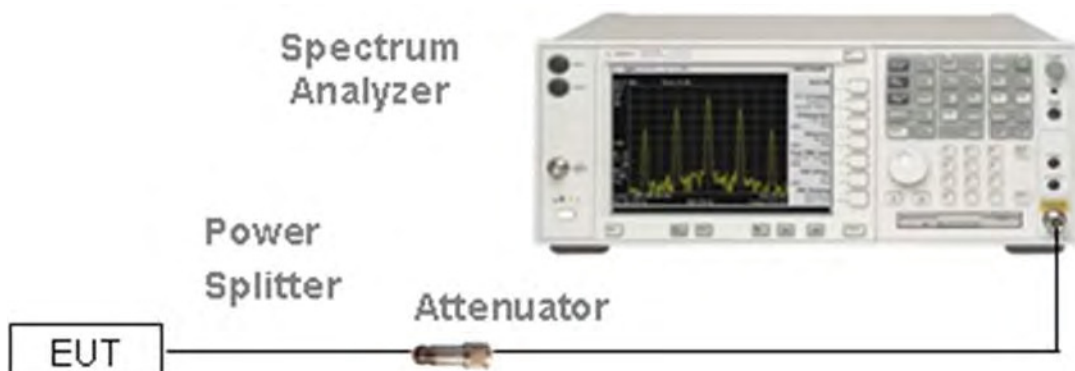

(Diagram 1)

4.5.2 For AC Power Supply Port Test

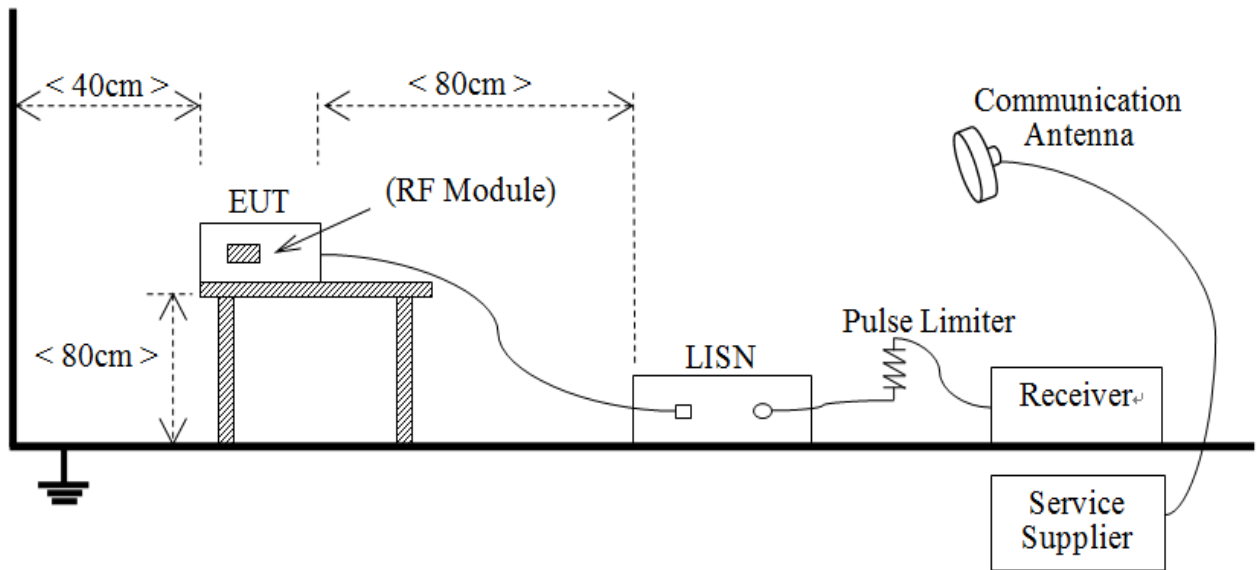

(Diagram 2)

4.5.3 For Radiated Test (Below 30 MHz)

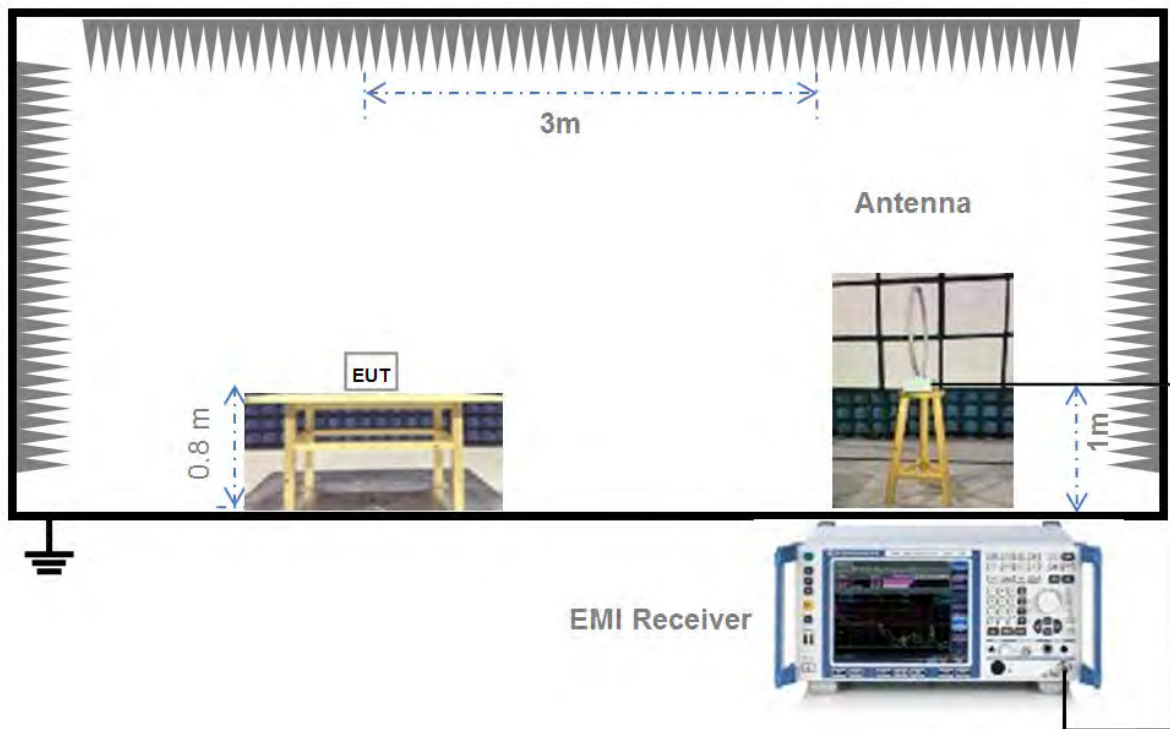

(Diagram 3)

4.5.4 For Radiated Test (30 MHz-1 GHz)

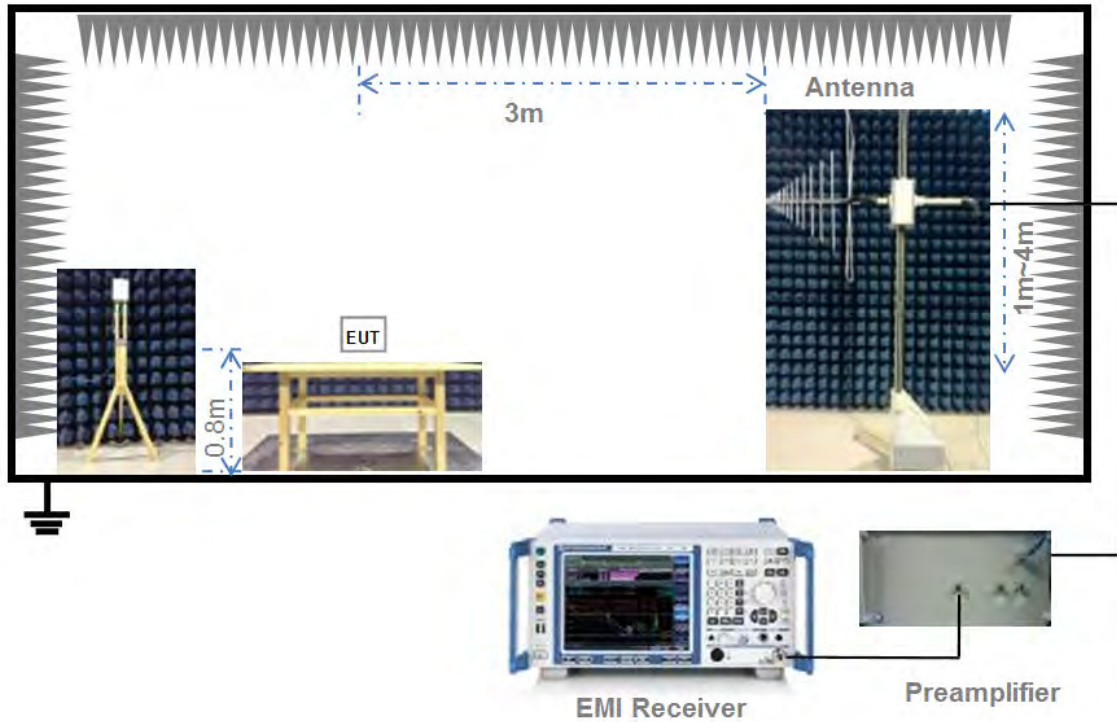

(Diagram 4)

4.5.5 For Radiated Test (Above 1 GHz)

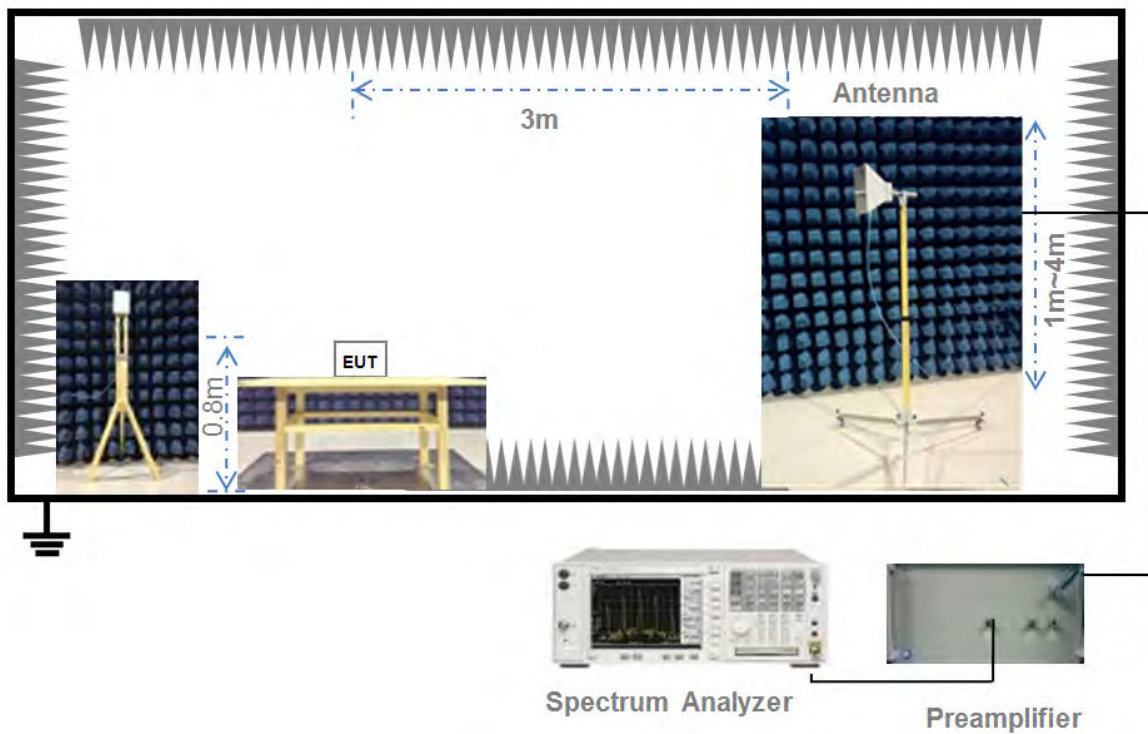

(Diagram 5)

4.6 Test Conditions

| Test Case | Test Conditions | | |
|---|-----------------|--|--|
| | Test Env. | Test Setup ^{Note 1} | Test Configuration ^{Note 2} |
| Peak Output Power | NTNV | Test Setup 1 | TC01~TC12 |
| Occupied Bandwidth | NTNV | Test Setup 1 | TC01~TC12 |
| Conducted Spurious Emission | NTNV | Test Setup 1 | TC01~TC12 |
| Conducted Emission | NTNV | Test Setup 2 | TC01~TC12 |
| Radiated Spurious Emission | NTNV | Test Setup 3 Test Setup 4 Test Setup 5 | TC01~TC12 |
| Band Edge | NTNV | Test Setup 1 | TC01, TC03, TC04, TC06, TC07, TC09, TC10, TC12 |
| Power spectral density (PSD) | NTNV | Test Setup 1 | TC01~TC12 |
| Note: 1. Please refer to section 4.4 for test setup details. 2. Please refer to section 4.3 for test configuration details. | | | |

5 TEST ITEMS

5.1 Antenna Requirements

5.1.1 Standard Applicable

RSS-247, 5.4 (6); FCC §15.203 & 15.247(b)

An intentional radiator shall be designed to ensure that no antenna other than that furnished by the responsible party shall be used with the device. The use of a permanently attached antenna or of an antenna that uses a unique coupling to the intentional radiator shall be considered sufficient to comply with the provisions of this section. The manufacturer may design the unit so that a broken antenna can be replaced by the user, but the use of a standard antenna jack or electrical connector is prohibited. This requirement does not apply to carrier current devices or to devices operated under the provisions of § 15.211, § 15.213, § 15.217, § 15.219, or § 15.221. Further, this requirement does not apply to intentional radiators that must be professionally installed, such as perimeter protection systems and some field disturbance sensors, or to other intentional radiators which, in accordance with § 15.31(d), must be measured at the installation site. However, the installer shall be responsible for ensuring that the proper antenna is employed so that the limits in this part are not exceeded.

If directional gain of transmitting antennas is greater than 6 dBi, the power shall be reduced by the same level in dB comparing to gain minus 6 dBi. For the fixed point-to-point operation, the power shall be reduced by one dB for every 3 dB that the directional gain of the antenna exceeds 6 dBi. The use of a permanently attached antenna or of an antenna that uses a unique coupling to the intentional radiator shall be considered sufficient to comply with the FCC rule.

5.1.2 Antenna Anti-Replacement Construction

Note: The antenna isn't welded on the mainboard, it is welded on another board, it is through the buckle line connection mainboard.

The Antenna Anti-Replacement as following method:

| Protected Method | Description |
|-------------------------------|--|
| The antenna is An embedded-in | An embedded-in antenna design is used. |

| Reference Documents | Item |
|---------------------|------|
| Photo | |

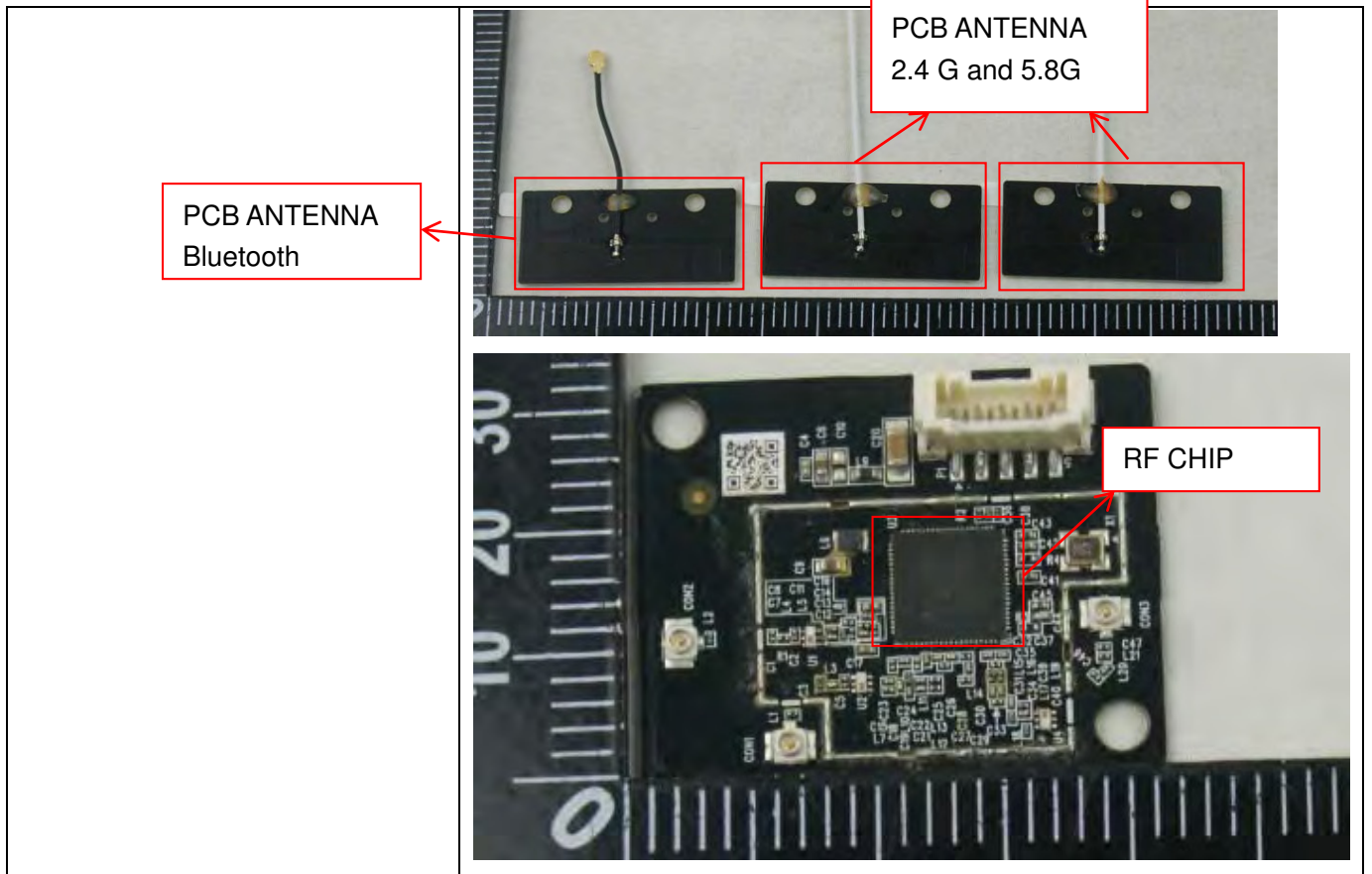

5.1.3 Antenna Gain

The antenna peak gain of EUT is less than 6 dBi. Therefore, it is not necessary to reduce maximum peak output power limit.

5.2 Output Power

5.2.1 Test Limit

RSS-247, 5.4 (4); FCC § 15.247(b)

For systems using digital modulation in the 902-928 MHz, 2400-2483.5 MHz, and 5725-5850 MHz bands: 1 Watt. As an alternative to a peak power measurement, compliance with the one Watt limit can be based on a measurement of the maximum conducted output power. Maximum Conducted Output Power is defined as the total transmit power delivered to all antennas and antenna elements averaged across all symbols in the signaling alphabet when the transmitter is operating at its maximum power control level. Power must be summed across all antennas and antenna elements.

5.2.2 Test Setup

See section 4.4.1 for test setup description for the antenna port. The photo of test setup please refer to ANNEX B.

5.2.3 Test Procedure

Maximum peak conducted output power

The maximum peak conducted output power may be measured using a broadband peak RF power meter. The power meter shall have a video bandwidth that is greater than or equal to the *DTS bandwidth* and shall utilize a fast-responding diode detector.

Maximum conducted (average) output power (Reporting Only)

a) As an alternative to spectrum analyzer or EMI receiver measurements, measurements may be performed using a wideband RF power meter with a thermocouple detector or equivalent if all of the conditions listed below are satisfied.

- 1) The EUT is configured to transmit continuously, or to transmit with a constant duty factor.
 - 2) At all times when the EUT is transmitting, it shall be transmitting at its maximum power control level.
 - 3) The integration period of the power meter exceeds the repetition period of the transmitted signal by at least a factor of five.
- b) If the transmitter does not transmit continuously, measure the duty cycle (x) of the transmitter output signal as described in Section 6.0.
- c) Measure the average power of the transmitter. This measurement is an average over both the on and off periods of the transmitter.
- d) Adjust the measurement in dBm by adding $10\log(1/x)$, where x is the duty cycle to the measurement result.

Measurements of duty cycle

The zero-span mode on a spectrum analyzer or EMI receiver if the response time and spacing between bins on the sweep are sufficient to permit accurate measurements of the on and off times of the transmitted signal.

Set the center frequency of the instrument to the center frequency of the transmission.

Set $RBW \geq OBW$ if possible; otherwise, set RBW to the largest available value.

Set $VBW \geq RBW$. Set detector = peak or average.

The zero-span measurement method shall not be used unless both RBW and VBW are $> 50/T$ and the number of sweep points across duration T exceeds 100. (For example, if VBW and/or RBW are limited to 3 MHz, then the zero-span method of measuring duty cycle shall not be used if $T \leq 16.7$ microseconds.)

5.2.4 Test Result

Please refer to ANNEX A.1.

5.3 6dB Bandwidth

5.3.1 Limit

RSS-GEN, 6.6; FCC §15.247(a)

Make the measurement with the spectrum analyzer's resolution bandwidth (RBW) = 100 kHz. In order to make an accurate measurement, set the span greater than RBW. The 6 dB bandwidth must be greater than 500 kHz.

5.3.2 Test Setup

See section 4.4.1 for test setup description for the antenna port. The photo of test setup please refer to ANNEX B.

5.3.3 Test Procedure

Use the following spectrum analyzer settings:

Set RBW = 100 kHz.

Set the video bandwidth (VBW) ≥ 3 RBW.

Detector = Peak.

Trace mode = max hold.

Sweep = auto couple.

Allow the trace to stabilize.

Measure the maximum width of the emission that is constrained by the frequencies associated with the two outermost amplitude points (upper and lower frequencies) that are attenuated by 6 dB relative to the maximum level measured in the fundamental emission.

5.3.4 Test Result

Please refer to ANNEX A.2.

5.4 Conducted Spurious Emission

5.4.1 Limit

FCC §15.247(c); RSS-247, 5.5

In any 100 kHz bandwidth outside the frequency band in which the spread spectrum or digitally modulated intentional radiator is operating, the radio frequency power that is produced by the intentional radiator shall be at least 20 dB below that in the 100 kHz bandwidth within the band that contains the highest level of the desired power, based on either an RF conducted or a radiated measurement.

5.4.2 Test Setup

See section 4.4.1 for test setup description for the antenna port. The photo of test setup please refer to ANNEX B.

5.4.3 Test Procedure

The DTS rules specify that in any 100 kHz bandwidth outside of the authorized frequency band, the power shall be attenuated according to the following conditions:

- a) If the maximum peak conducted output power procedure was used to demonstrate compliance as described in 9.1, then the peak output power measured in any 100 kHz bandwidth outside of the authorized frequency band shall be attenuated by at least 20 dB relative to the maximum in-band peak PSD level in 100 kHz (i.e., 20 dBc).
- b) If maximum conducted (average) output power was used to demonstrate compliance as described in 9.2, then the peak power in any 100 kHz bandwidth outside of the authorized frequency band shall be attenuated by at least 30 dB relative to the maximum in-band peak PSD level in 100 kHz (i.e., 30 dBc).
- c) In either case, attenuation to levels below the 15.209 general radiated emissions limits is not required.

The following procedures shall be used to demonstrate compliance to these limits. Note that these procedures can be used in either an antenna-port conducted or radiated test set-up. Radiated tests must conform to the test site requirements and utilize maximization procedures defined herein.

Reference level measurement

Establish a reference level by using the following procedure:

Set instrument center frequency to DTS channel center frequency.

Set the span to ≥ 1.5 times the DTS bandwidth.

Set the RBW = 100 kHz.

Set the VBW $\geq 3 \times$ RBW.

Detector = peak.

Sweep time = auto couple.

Trace mode = max hold.

Allow trace to fully stabilize.

Use the peak marker function to determine the maximum PSD level.

Emission level measurement

Use the following spectrum analyzer settings:

Span = wide enough to capture the peak level of the in-band emission and all spurious emissions (e.g., harmonics) from the lowest frequency generated in the EUT up through the 10th harmonic. Typically, several plots are required to cover this entire span.

Set the RBW = 100 kHz.

Set the VBW $\geq 3 \times$ RBW.

Detector = peak.

Sweep time = auto couple.

Trace mode = max hold.

Allow trace to fully stabilize.

Use the peak marker function to determine the maximum amplitude level.

Ensure that the amplitude of all unwanted emissions outside of the authorized frequency band (excluding restricted frequency bands) are attenuated by at least the minimum requirements specified in 11.1 a) or 11.1 b). Report the three highest emissions relative to the limit.

5.4.4 Test Result

Please refer to ANNEX A.3.

5.5 Band Edge (Authorized-band band-edge)

5.5.1 Limit

FCC §15.247(d); RSS-247, 5.5

In any 100 kHz bandwidth outside the frequency band in which the spread spectrum or digitally modulated intentional radiator is operating, the radio frequency power that is produced by the intentional radiator shall be at least 20 dB below that in the 100 kHz bandwidth within the band that contains the highest level of the desired power, based on either an RF conducted or a radiated measurement.

5.5.2 Test Setup

See section 4.4.1 for test setup description for the antenna port. The photo of test setup please refer to ANNEX B.

5.5.3 Test Procedure

This Method apply to the equipment is using FHSS.

Span = wide enough to capture the peak level of the emission operating on the channel closest to the band edge, as well as any modulation products which fall outside of the authorized band of operation

RBW \geq 1% of the span

VBW \geq RBW

Sweep = auto

Detector function = peak /AV

Trace = max hold

Allow the trace to stabilize.

E [dB μ V/m] =UR + AT + AFactor [dB]; AT =LCable loss [dB] - Gpreamp [dB]

AT: Total correction Factor except Antenna

UR: Receiver Reading

Gpreamp: Preamplifier Gain

AFactor: Antenna Factor at 3m

This Method apply to the equipment is using wide band modulations other than FHSS.

The following procedures may be used to determine the peak or average field strength or power of an unwanted emission that is within 2 MHz of the authorized band edge. If a peak detector is utilized, use the procedure described in 13.2.1. Use the procedure described in 13.2.2 when using an average detector and the EUT can be configured to transmit continuously (i.e., duty cycle \geq 98%). Use the procedure described in 13.2.3 when using an average detector and the EUT cannot be configured to transmit continuously but the duty cycle is constant (i.e., duty cycle variations are less than \pm 2 percent). Use the procedure described in 13.2.4 when using an average detector for those cases where the EUT cannot be configured to transmit continuously and the duty cycle is not constant (duty cycle variations equal or exceed 2 percent).

When using a peak detector to measure unwanted emissions at or near the band edge (within 2 MHz of the authorized band), the following integration procedure can be used.

Set instrument center frequency to the frequency of the emission to be measured (must be within 2 MHz of the authorized band edge).

Set span to 2 MHz

RBW = 100 kHz.

VBW $\geq 3 \times$ RBW.

Detector = peak.

Sweep time = auto.

Trace mode = max hold.

Allow sweep to continue until the trace stabilizes (required measurement time may increase for low duty cycle applications)

Compute the power by integrating the spectrum over 1 MHz using the analyzer's band power measurement function with band limits set equal to the emission frequency (femission) ± 0.5 MHz. If the instrument does not have a band power function, then sum the amplitude levels (in power units) at 100 kHz intervals extending across the 1 MHz spectrum defined by femission ± 0.5 MHz.

5.5.4 Test Result

Please refer to ANNEX A.4.

5.6 Conducted Emission

5.6.1 Limit

FCC §15.207; RSS-GEN, 8.8

For an intentional radiator that is designed to be connected to the public utility (AC) power line, the radio frequency voltage that is conducted back onto the AC power line on any frequency within the band 150 kHz to 30 MHz shall not exceed the limits in the following table, as measured using a 50 μ H/50 Ω line impedance stabilization network (LISN).

| Frequency range (MHz) | Conducted Limit (dB μ V) | |
|--------------------------|------------------------------|----------|
| | Quai-peak | Average |
| 0.15 - 0.50 | 66 to 56 | 56 to 46 |
| 0.50 - 5 | 56 | 46 |
| 0.50 - 30 | 60 | 50 |

5.6.2 Test Setup

See section 4.4.2 for test setup description for the AC power supply port. The photo of test setup please refer to ANNEX B.

5.6.3 Test Procedure

The maximum conducted interference is searched using Peak (PK), if the emission levels more than the AV and QP limits, and that have narrow margins from the AV and QP limits will be re-measured with AV and QP detectors. Tests for both L phase and N phase lines of the power mains connected to the EUT are performed. Refer to recorded points and plots below.

5.6.4 Test Result

Please refer to ANNEX A.5.

5.7 Radiated Spurious Emission

5.7.1 Limit

FCC §15.209&15.247(c); RSS-247, 5.5

Radiated emission outside the frequency band attenuation below the general limits specified in FCC section 15.209(a) is not required. In addition, radiated emissions which fall in the restricted bands, as defined in FCC section 15.205(a), must also comply with the radiated emission limits specified in FCC section 15.209(a).

According to FCC section 15.209 (a), except as provided elsewhere in this subpart, the emissions from an intentional radiator shall not exceed the field strength levels specified in the following table:

| Frequency (MHz) | Field Strength ($\mu\text{V}/\text{m}$) | Measurement Distance (m) |
|-----------------|---|--------------------------|
| 0.009 - 0.490 | 2400/F(kHz) | 300 |
| 0.490 - 1.705 | 24000/F(kHz) | 30 |
| 1.705 - 30.0 | 30 | 30 |
| 30 - 88 | 100 | 3 |
| 88 - 216 | 150 | 3 |
| 216 - 960 | 200 | 3 |
| Above 960 | 500 | 3 |

Note:

1. For Above 1000 MHz, the emission limit in this paragraph is based on measurement instrumentation employing an average detector, measurement using instrumentation with a peak detector function, corresponding to 20dB above the maximum permitted average limit.
2. For above 1000 MHz, limit field strength of harmonics: 54dBuV/m@3m (AV) and 74dBuV/m@3m (PK).

5.7.2 Test Setup

See section 4.4.2-4.4.5 for test setup description for the antenna port. The photo of test setup please refer to ANNEX B.

5.7.3 Test Procedure

Since the emission limits are specified in terms of radiated field strength levels, measurements performed to demonstrate compliance have traditionally relied on a radiated test configuration. Radiated measurements remain the principal method for demonstrating compliance to the specified limits; however antenna-port conducted measurements are also now acceptable to demonstrate compliance (see below for details). When radiated measurements are utilized, test site requirements and procedures for maximizing and measuring radiated emissions that are described in ANSI C63.10 shall be followed.

Antenna-port conducted measurements may also be used as an alternative to radiated measurements for demonstrating compliance in the restricted frequency bands. If conducted measurements are performed, then proper impedance matching must be ensured and an additional radiated test for cabinet/case spurious emissions is required.

General Procedure for conducted measurements in restricted bands

- a) Measure the conducted output power (in dBm) using the detector specified (see guidance regarding measurement procedures for determining quasi-peak, peak, and average conducted output power, respectively).

- b) Add the maximum transmit antenna gain (in dBi) to the measured output power level to determine the EIRP level (see guidance on determining the applicable antenna gain)
- c) Add the appropriate maximum ground reflection factor to the EIRP level (6 dB for frequencies ≤ 30 MHz, 4.7 dB for frequencies between 30 MHz and 1000 MHz, inclusive and 0 dB for frequencies > 1000 MHz).
- d) For devices with multiple antenna-ports, measure the power of each individual chain and sum the EIRP of all chains in linear terms (e.g., Watts, mW).
- e) Convert the resultant EIRP level to an equivalent electric field strength using the following relationship:

$$E = \text{EIRP} - 20\log D + 104.8$$

where:

E = electric field strength in dBμV/m,

EIRP = equivalent isotropic radiated power in dBm

D = specified measurement distance in meters.

- f) Compare the resultant electric field strength level to the applicable limit.
- g) Perform radiated spurious emission test.

Quasi-Peak measurement procedure

The specifications for measurements using the CISPR quasi-peak detector can be found in Publication 16 of the International Special Committee on Radio Frequency Interference (CISPR) of the International Electrotechnical Commission.

As an alternative to CISPR quasi-peak measurement, compliance can be demonstrated to the applicable emission limits using a peak detector.

Peak power measurement procedure

Peak emission levels are measured by setting the instrument as follows:

- a) RBW = as specified in Table 1.
- b) VBW ≥ 3 x RBW.
- c) Detector = Peak.
- d) Sweep time = auto.
- e) Trace mode = max hold.
- f) Allow sweeps to continue until the trace stabilizes. (Note that the required measurement time may be longer for low duty cycle applications).

Table 1—RBW as a function of frequency

| Frequency | RBW |
|-------------|-------------|
| 9-150 kHz | 200-300 Hz |
| 0.15-30 MHz | 9-10 kHz |
| 30-1000 MHz | 100-120 kHz |

| | |
|------------|-------|
| > 1000 MHz | 1 MHz |
|------------|-------|

If the peak-detected amplitude can be shown to comply with the average limit, then it is not necessary to perform a separate average measurement.

Trace averaging across on and off times of the EUT transmissions followed by duty cycle correction

If continuous transmission of the EUT (i.e., duty cycle ≥ 98 percent) cannot be achieved and the duty cycle is constant (i.e., duty cycle variations are less than ± 2 percent), then the following procedure shall be used:

- a) The EUT shall be configured to operate at the maximum achievable duty cycle.
- b) Measure the duty cycle, x , of the transmitter output signal as described in section 6.0.
- c) RBW = 1 MHz (unless otherwise specified).
- d) VBW $\geq 3 \times$ RBW.
- e) Detector = RMS, if $\text{span}/(\# \text{ of points in sweep}) \leq (\text{RBW}/2)$. Satisfying this condition may require increasing the number of points in the sweep or reducing the span. If this condition cannot be satisfied, then the detector mode shall be set to peak.
- f) Averaging type = power (i.e., RMS).
 - 1) As an alternative, the detector and averaging type may be set for linear voltage averaging.
 - 2) Some instruments require linear display mode in order to use linear voltage averaging. Log or dB averaging shall not be used.
- g) Sweep time = auto.
- h) Perform a trace average of at least 100 traces.
- i) A correction factor shall be added to the measurement results prior to comparing to the emission limit in order to compute the emission level that would have been measured had the test been performed at 100 percent duty cycle. The correction factor is computed as follows:
 - 1) If power averaging (RMS) mode was used in step f), then the applicable correction factor is $10 \log(1/x)$, where x is the duty cycle.
 - 2) If linear voltage averaging mode was used in step f), then the applicable correction factor is $20 \log(1/x)$, where x is the duty cycle.
 - 3) If a specific emission is demonstrated to be continuous (≥ 98 percent duty cycle) rather than turning on and off with the transmit cycle, then no duty cycle correction is required for that emission.

NOTE: Reduction of the measured emission amplitude levels to account for operational duty factor is not permitted. Compliance is based on emission levels occurring during transmission - not on an average across on and off times of the transmitter.

Determining the applicable transmit antenna gain

A conducted power measurement will determine the maximum output power associated with a restricted band emission; however, in order to determine the associated EIRP level, the gain of the transmitting antenna (in dBi)

must be added to the measured output power (in dBm).

Since the out-of-band characteristics of the EUT transmit antenna will often be unknown, the use of a conservative antenna gain value is necessary. Thus, when determining the EIRP based on the measured conducted power, the upper bound on antenna gain for a device with a single RF output shall be selected as the maximum in-band gain of the antenna across all operating bands, or 2 dBi, whichever is greater. However, for devices that operate in multiple frequency bands while using the same transmit antenna, the highest gain of the antenna within the operating band nearest in frequency to the restricted band emission being measured may be used in lieu of the overall highest gain when the emission is at a frequency that is within 20 percent of the nearest band edge frequency, but in no case shall a value less than 2 dBi be used.

See KDB 662911 for guidance on calculating the additional array gain term when determining the effective antenna gain for a EUT with multiple outputs occupying the same or overlapping frequency ranges in the same band.

Radiated spurious emission test

An additional consideration when performing conducted measurements of restricted band emissions is that unwanted emissions radiating from the EUT cabinet, control circuits, power leads, or intermediate circuit elements will likely go undetected in a conducted measurement configuration. To address this concern, a radiated test shall be performed to ensure that emissions emanating from the EUT cabinet (rather than the antenna port) also comply with the applicable limits.

For these cabinet radiated spurious emission measurements the EUT transmit antenna may be replaced with a termination matching the nominal impedance of the antenna. Procedures for performing radiated measurements are specified in ANSI C63.10. All detected emissions shall comply with the applicable limits.

The measurement frequency range is from 30 MHz to the 10th harmonic of the fundamental frequency. The Turn Table is actuated to turn from 0° to 360°, and both horizontal and vertical polarizations of the Test Antenna are used to find the maximum radiated power. Mid channels on all channel bandwidth verified. Only the worst RB size/offset presented.

The power of the EUT transmitting frequency should be ignored.

All Spurious Emission tests were performed in X, Y, Z axis direction. And only the worst axis test condition was recorded in this test report.

Use the following spectrum analyzer settings:

Span = wide enough to fully capture the emission being measured

RBW = 1 MHz for $f \geq 1$ GHz, 100 kHz for $f < 1$ GHz

VBW \geq RBW

Sweep = auto

Detector function = peak

Trace = max hold

5.7.4 Test Result

Please refer to ANNEX A.6.

5.8 Power Spectral density (PSD)

5.8.1 Limit

FCC §15.247(d); RSS-247, 5.2 (2)

The same method of determining the conducted output power shall be used to determine the power spectral density. If a peak output power is measured, then a peak power spectral density measurement is required. If an average output power is measured, then an average power spectral density measurement should be used.

5.8.2 Test Setup

See section 4.4.1 for test setup description for the antenna port. The photo of test setup please refer to ANNEX B.

5.8.3 Test Procedure

Set analyzer center frequency to DTS channel center frequency.

Set the span to 1.5 times the DTS bandwidth.

Set the RBW to: $3 \text{ kHz} \leq \text{RBW} \leq 100 \text{ kHz}$.

Set the VBW $\geq 3 \text{ RBW}$.

Detector = peak.

Sweep time = auto couple.

Trace mode = max hold.

Allow trace to fully stabilize.

Use the peak marker function to determine the maximum amplitude level within the RBW.

If measured value exceeds limit, reduce RBW (no less than 3 kHz) and repeat.

5.8.4 Test Result

Please refer to ANNEX A.7.

5.9 Receiver Spurious Emissions

5.9.1 Limit

IC RSS-Gen, 7.1.2

Radiated spurious emission measurements shall be performed with the receiver antenna connected to the receiver antenna terminals. Spurious emissions from receivers shall not exceed the radiated limits shown in the table below:

| Frequency (MHz) | Field Strength ($\mu\text{V/m}$) | Measurement Distance (m) |
|-----------------|------------------------------------|--------------------------|
| 30 - 88 | 100 | 3 |
| 88 - 216 | 150 | 3 |
| 216 - 960 | 200 | 3 |
| Above 960 | 500 | 3 |

5.9.2 Test Setup

See section 4.4.3-5 (Diagram 3-5) for test setup description for the antenna port. The photo of test setup please refer to ANNEX B.

5.9.3 Test Procedure

The measurement frequency range is from 30 MHz to the 10th harmonic of the fundamental frequency. The Turn Table is actuated to turn from 0° to 360° , and both horizontal and vertical polarizations of the Test Antenna are used to find the maximum radiated power. Mid channels on all channel bandwidth verified. Only the worst RB size/offset presented.

Test Plots for the Whole Measurement Frequency Range:

The power of the EUT transmitting frequency should be ignored.

All Spurious Emission tests were performed in X, Y, Z axis direction. And only the worst axis test condition was recorded in this test report.

Use the following spectrum analyzer settings:

Span = wide enough to fully capture the emission being measured

RBW = 1 MHz for $f \geq 1$ GHz, 100 kHz for $f < 1$ GHz

VBW \geq RBW

Sweep = auto

Detector function = peak

Trace = max hold

5.9.4 Test Result

Please refer to ANNEX A.8.

ANNEX A TEST RESULT

A.1 Output Power

Duty Cycle

| Antenna | Mode | Duty Cycle (%) | T (ms) | 1/T (kHz) |
|---------|--------------|----------------|--------|-----------|
| ANT 0 | 802.11b | 97.38 | 8.667 | 0.1152 |
| | 802.11g | 86.16 | 1.413 | 0.6978 |
| | 802.11n HT20 | 85.83 | 1.333 | 0.7576 |
| | 802.11n HT40 | 72.31 | 0.627 | 1.5798 |
| ANT 1 | 802.11b | 97.38 | 8.667 | 0.1149 |
| | 802.11b | 86.22 | 1.420 | 0.7077 |
| | 802.11n HT20 | 85.90 | 1.340 | 0.7576 |
| | 802.11n HT40 | 71.76 | 0.627 | 1.5798 |

Peak Power Test Data

802.11b Mode:

| Channel | Measured Output Peak Power Of ANT 0 | | Measured Output Peak Power Of ANT 1 | | Total of output power | | Limit | | Verdict |
|---------|-------------------------------------|-------|-------------------------------------|-------|-----------------------|-------|-------|------|---------|
| | dBm | mW | dBm | mW | dBm | mW | dBm | mW | |
| Low | 15.88 | 38.73 | 16.02 | 39.99 | 18.96 | 78.72 | 30 | 1000 | Pass |
| Middle | 16.67 | 46.45 | 15.78 | 37.84 | 19.26 | 84.30 | | | Pass |
| High | 16.36 | 43.25 | 15.76 | 37.67 | 19.08 | 80.92 | | | Pass |

802.11g Mode:

| Channel | Measured Output Peak Power Of ANT 0 | | Measured Output Peak Power Of ANT 1 | | Total of output power | | Limit | | Verdict |
|---------|-------------------------------------|-------|-------------------------------------|-------|-----------------------|-------|-------|------|---------|
| | dBm | mW | dBm | mW | dBm | mW | dBm | mW | |
| Low | 14.94 | 31.19 | 15.35 | 34.28 | 18.16 | 65.47 | 30 | 1000 | Pass |
| Middle | 14.57 | 28.64 | 15.21 | 33.19 | 17.91 | 61.83 | | | Pass |
| High | 15.08 | 32.21 | 15.58 | 36.14 | 18.35 | 68.35 | | | Pass |

802.11n-20 MHz Mode:

| Channel | Measured Output Peak Power Of ANT 0 | | Measured Output Peak Power Of ANT 1 | | Total of output power | | Limit | | Verdict |
|---------|-------------------------------------|-------|-------------------------------------|-------|-----------------------|-------|-------|------|---------|
| | dBm | mW | dBm | mW | dBm | mW | dBm | mW | |
| Low | 14.87 | 30.69 | 14.81 | 30.27 | 17.85 | 60.96 | 30 | 1000 | Pass |
| Middle | 14.37 | 27.35 | 15.33 | 34.12 | 17.89 | 61.47 | | | Pass |
| High | 14.87 | 30.69 | 15.36 | 34.36 | 18.13 | 65.05 | | | Pass |

802.11n-40 MHz Mode:

| Channel | Measured Output Peak Power Of ANT 0 | | Measured Output Peak Power Of ANT 1 | | Total of output power | | Limit | | Verdict |
|---------|-------------------------------------|-------|-------------------------------------|-------|-----------------------|-------|-------|------|---------|
| | dBm | mW | dBm | mW | dBm | mW | dBm | mW | |
| Low | 14.27 | 26.73 | 14.75 | 29.85 | 17.53 | 56.58 | 30 | 1000 | Pass |
| Middle | 14.15 | 26.00 | 14.71 | 29.58 | 17.45 | 55.58 | | | Pass |
| High | 14.07 | 25.53 | 15.35 | 34.28 | 17.77 | 59.80 | | | Pass |

A.2 Bandwidth

Test Data

ANT 0

802.11b Mode:

| Channel | 6 dB Bandwidth (MHz) | 99% Bandwidth (MHz) | Limits (kHz) |
|---------|----------------------|---------------------|--------------|
| Low | 10.073 | 12.4809 | ≥ 500 |
| Middle | 10.106 | 12.3211 | ≥ 500 |
| High | 10.085 | 12.2805 | ≥ 500 |

802.11g Mode:

| Channel | 6 dB Bandwidth (MHz) | 99% Bandwidth (MHz) | Limits (kHz) |
|---------|----------------------|---------------------|--------------|
| Low | 16.338 | 16.6041 | ≥ 500 |
| Middle | 16.077 | 16.4656 | ≥ 500 |
| High | 16.049 | 16.4600 | ≥ 500 |

802.11n-20MHz Mode:

| Channel | 6 dB Bandwidth (MHz) | 99% Bandwidth (MHz) | Limits (kHz) |
|---------|----------------------|---------------------|--------------|
| Low | 16.989 | 17.6252 | ≥ 500 |
| Middle | 16.928 | 17.5781 | ≥ 500 |
| High | 16.971 | 17.6069 | ≥ 500 |

802.11n-40MHz Mode:

| Channel | 6 dB Bandwidth (MHz) | 99% Bandwidth (MHz) | Limits (kHz) |
|---------|----------------------|---------------------|--------------|
| Low | 35.244 | 36.0067 | ≥ 500 |
| Middle | 35.494 | 35.9316 | ≥ 500 |
| High | 35.264 | 35.9201 | ≥ 500 |

ANT 1

802.11b Mode:

| Channel | 6 dB Bandwidth (MHz) | 99% Bandwidth (MHz) | Limits (kHz) |
|---------|----------------------|---------------------|--------------|
| Low | 10.065 | 12.5683 | ≥ 500 |
| Middle | 10.081 | 12.4948 | ≥ 500 |
| High | 10.066 | 12.4446 | ≥ 500 |

802.11g Mode:

| Channel | 6 dB Bandwidth (MHz) | 99% Bandwidth (MHz) | Limits (kHz) |
|---------|----------------------|---------------------|--------------|
| Low | 16.318 | 16.5590 | ≥ 500 |
| Middle | 16.290 | 16.5876 | ≥ 500 |
| High | 15.710 | 16.5216 | ≥ 500 |

802.11n-20MHz Mode:

| Channel | 6 dB Bandwidth (MHz) | 99% Bandwidth (MHz) | Limits (kHz) |
|---------|----------------------|---------------------|--------------|
| Low | 17.313 | 17.6631 | ≥ 500 |
| Middle | 16.317 | 17.6495 | ≥ 500 |
| High | 16.194 | 17.6543 | ≥ 500 |

802.11n-40MHz Mode:

| Channel | 6 dB Bandwidth (MHz) | 99% Bandwidth (MHz) | Limits (kHz) |
|---------|----------------------|---------------------|--------------|
| Low | 35.268 | 36.1119 | ≥ 500 |
| Middle | 35.199 | 36.1100 | ≥ 500 |
| High | 35.244 | 35.0881 | ≥ 500 |

Test plots

ANT 0

802.11b LOW CHANNEL



802.11b MIDDLE CHANNEL

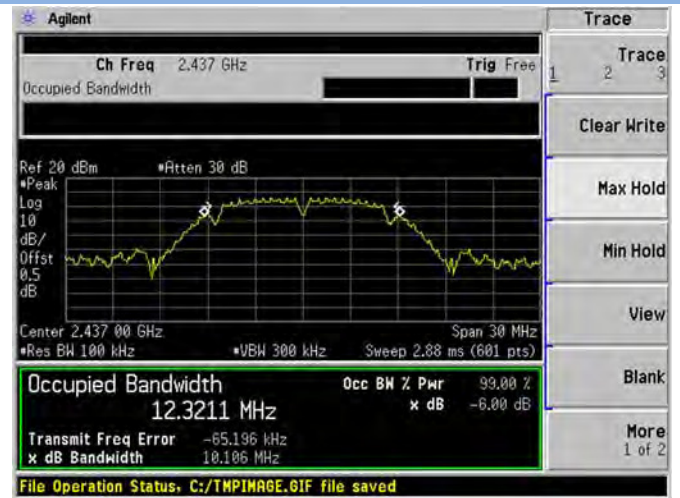

802.11b HIGH CHANNEL

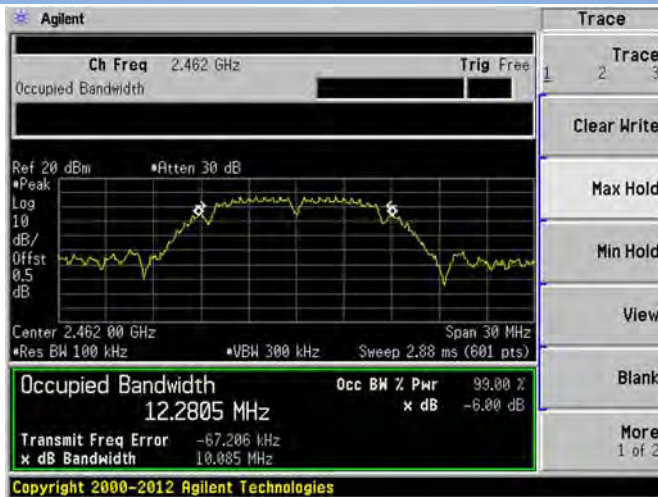

802.11g LOW CHANNEL

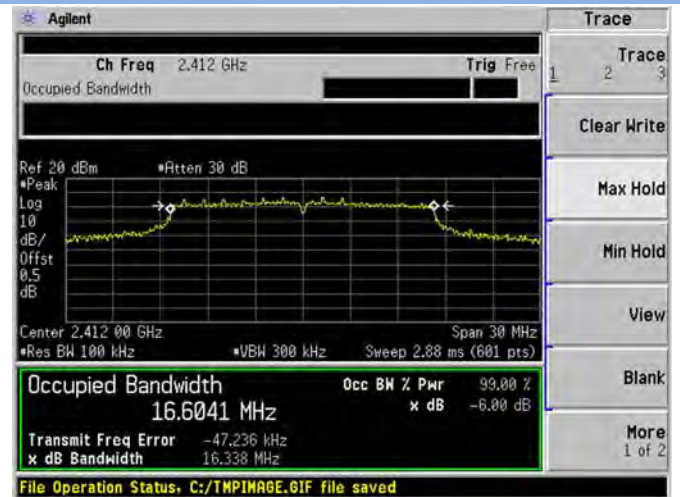

802.11g MIDDLE CHANNEL

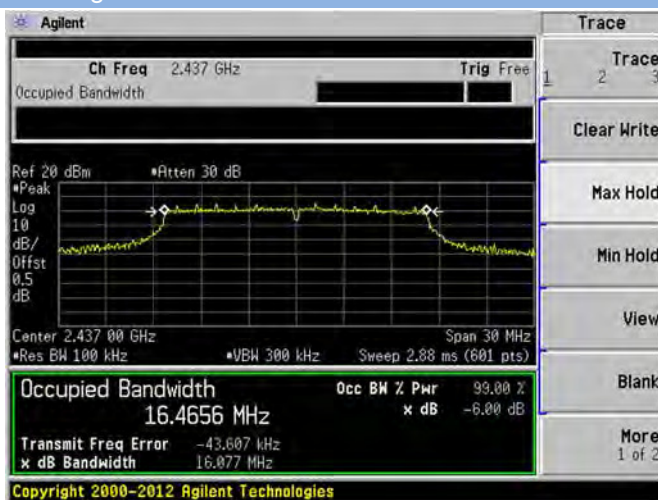

802.11g HIGH CHANNEL

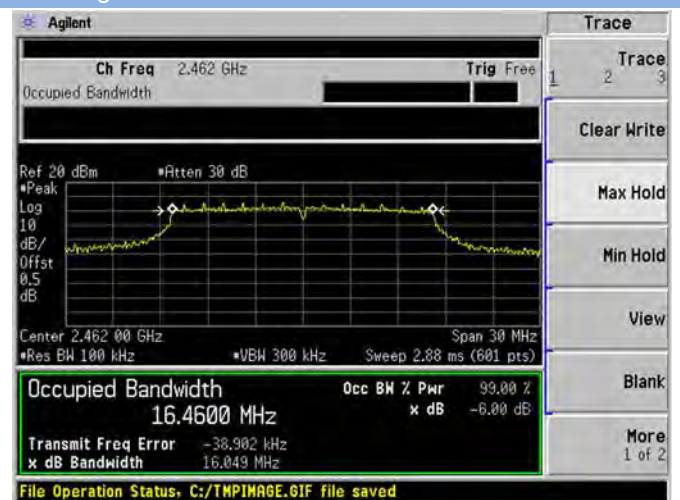

802.11n-20 MHz LOW CHANNEL

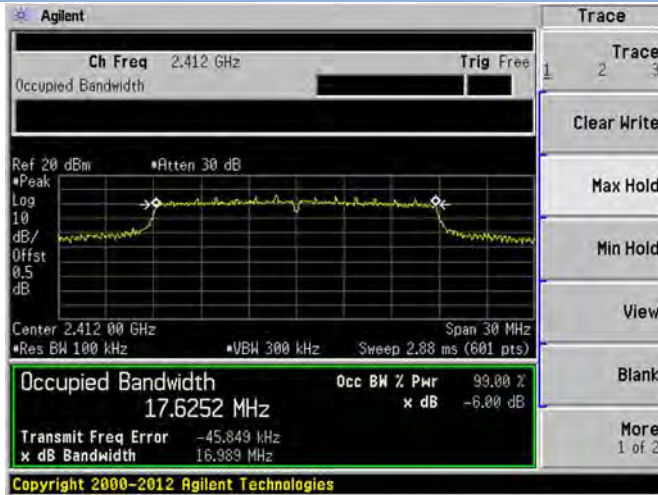

802.11 n-20 MHz MIDDLE CHANNEL

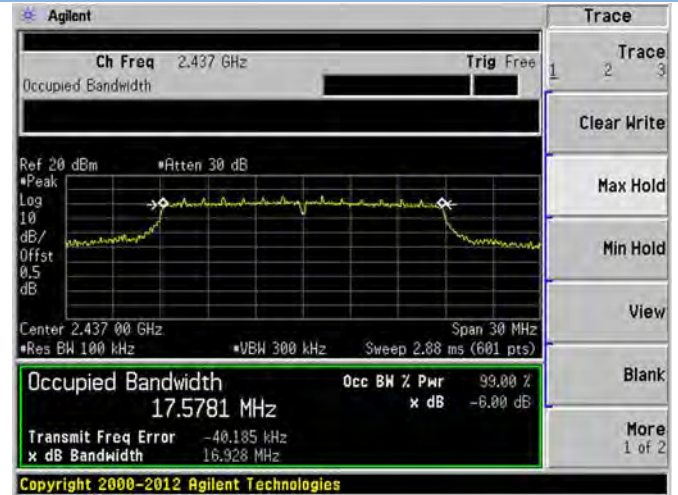

802.11n-20 MHz HIGH CHANNEL

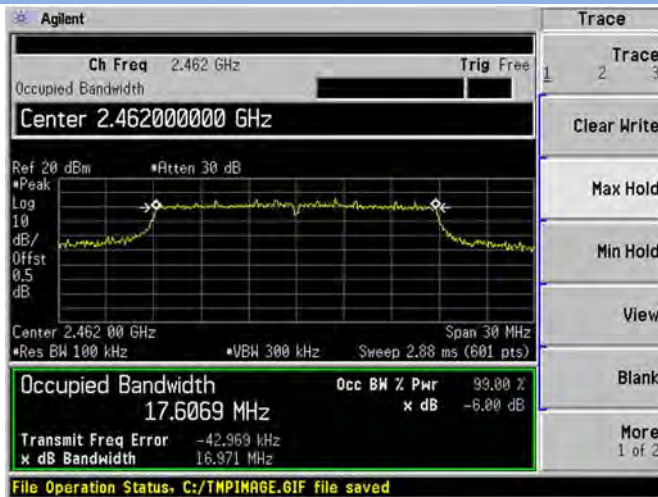

802.11n-40 MHz LOW CHANNEL

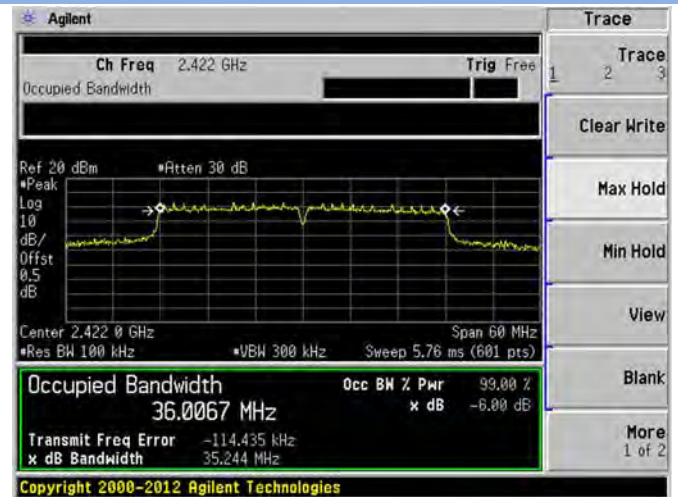

802.11n-40 MHz MIDDLE CHANNEL

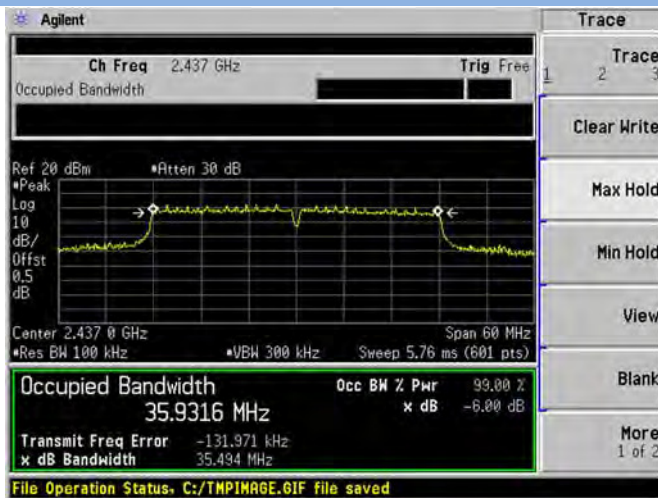

802.11n-40 MHz HIGH CHANNEL

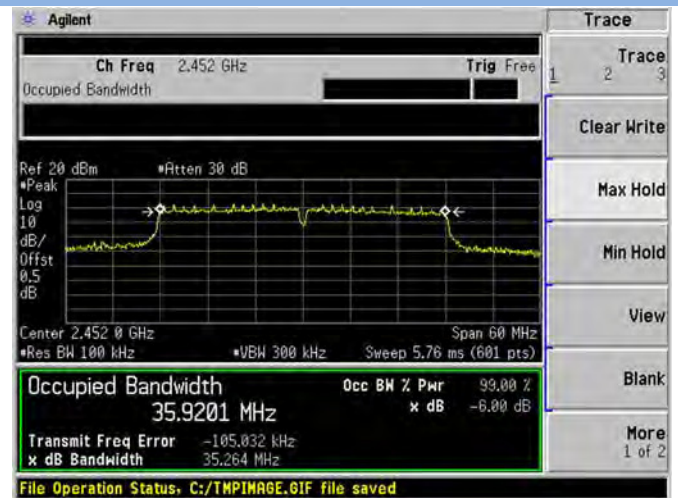

ANT 1

802.11b LOW CHANNEL

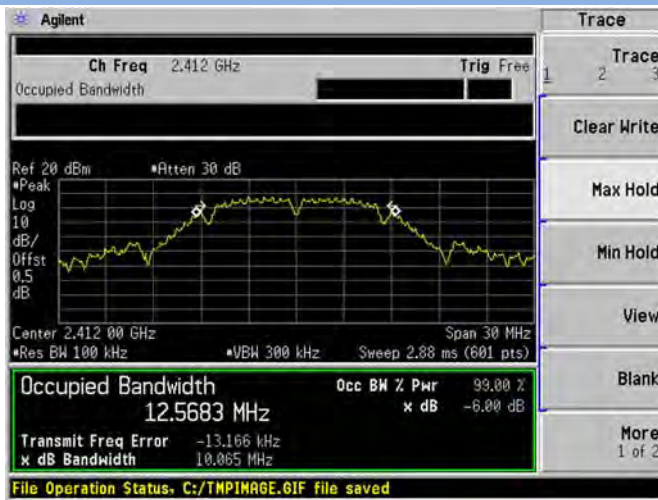

802.11b MIDDLE CHANNEL

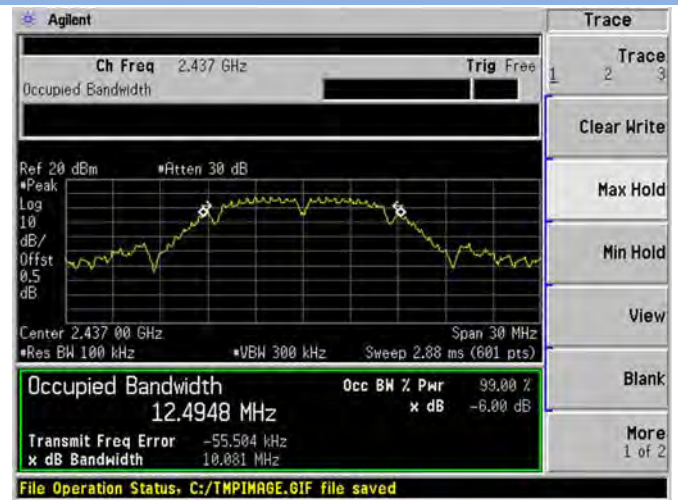

802.11b HIGH CHANNEL

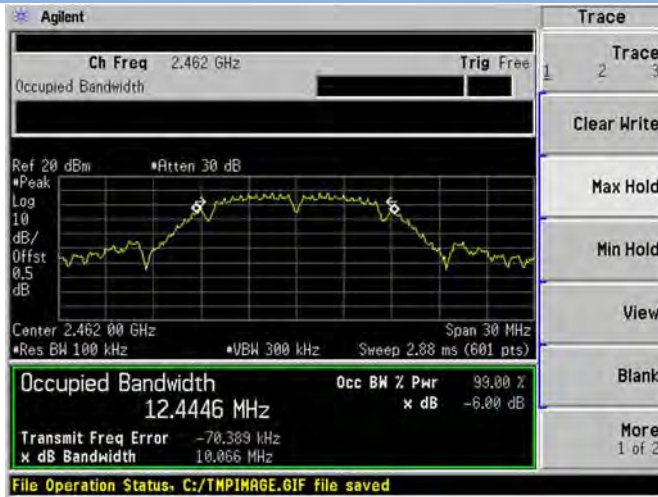

802.11g LOW CHANNEL

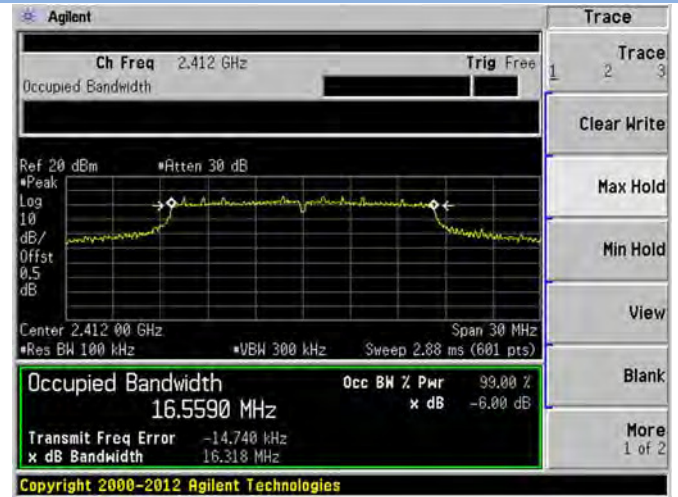

802.11g MIDDLE CHANNEL

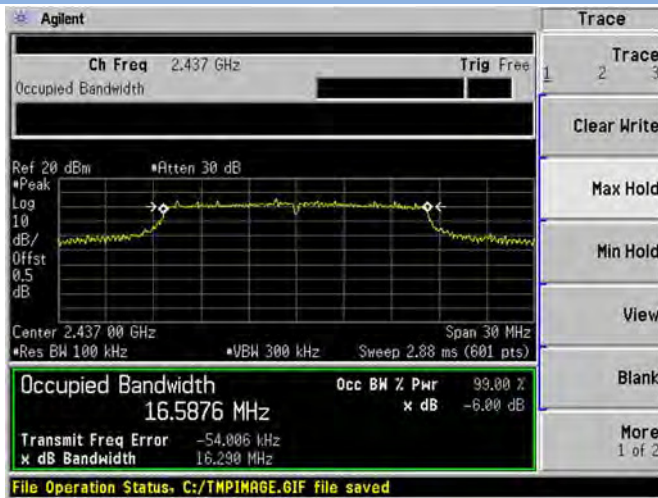

802.11g HIGH CHANNEL

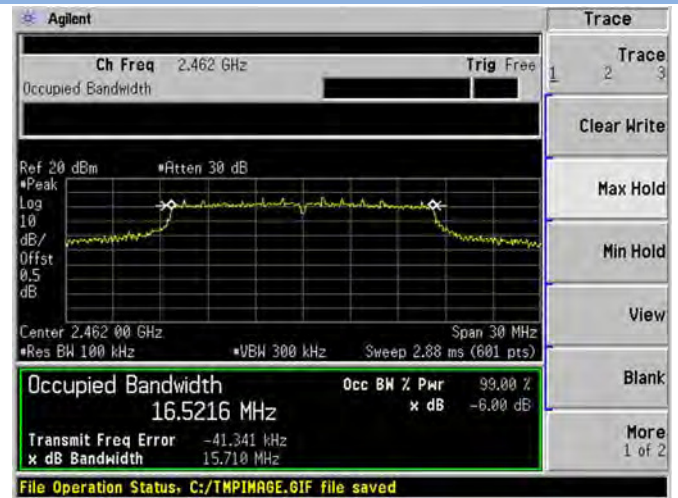

802.11n-20 MHz LOW CHANNEL

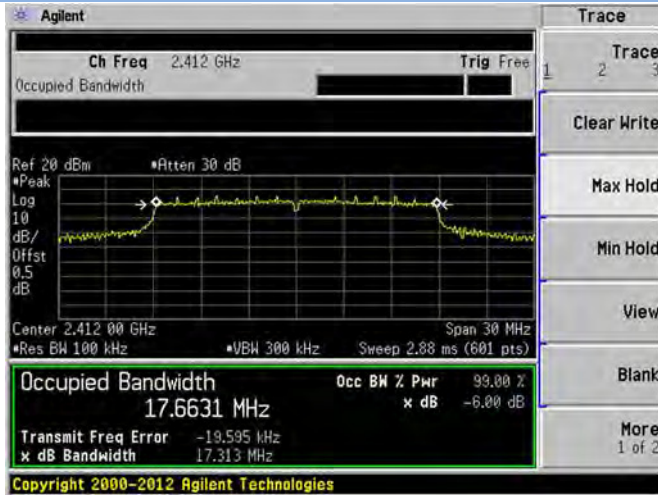

802.11 n-20 MHz MIDDLE CHANNEL

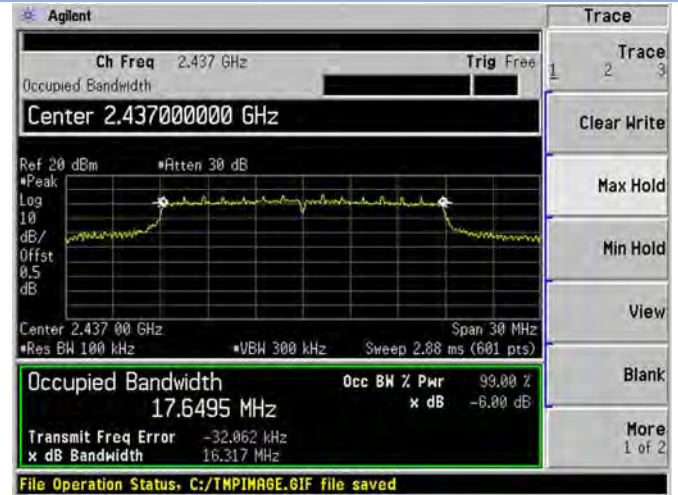

802.11n-20 MHz HIGH CHANNEL

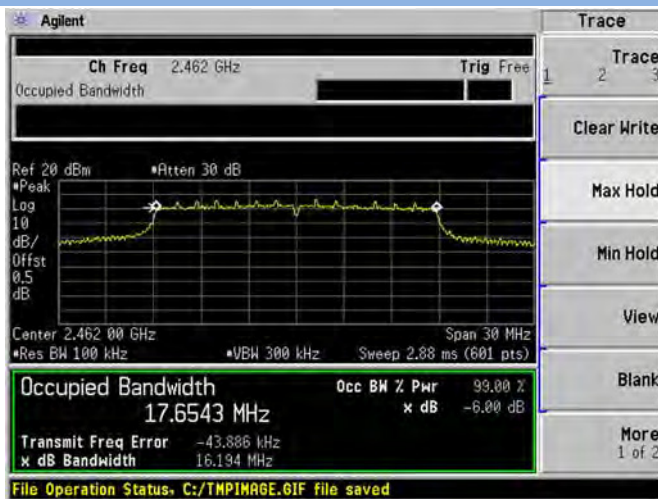

802.11n-40 MHz LOW CHANNEL

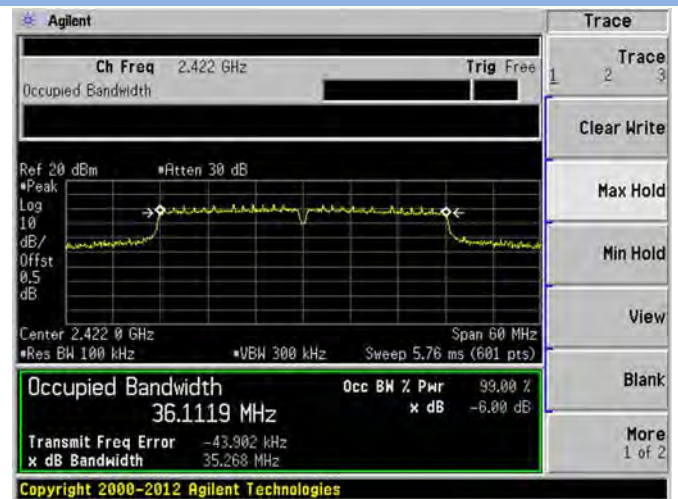

802.11n-40 MHz MIDDLE CHANNEL

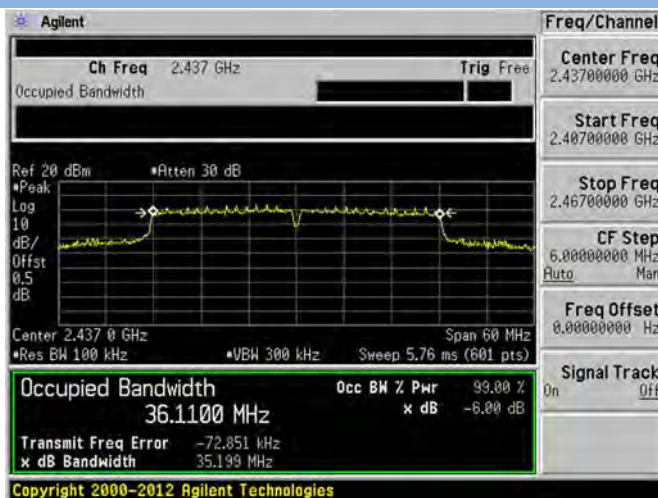

802.11n-40 MHz HIGH CHANNEL

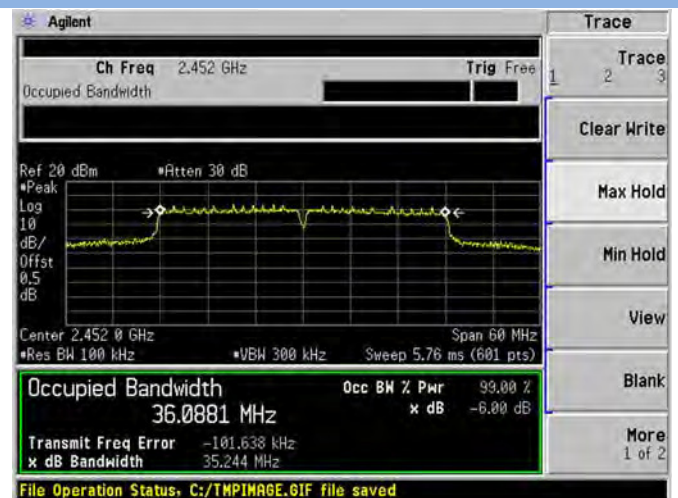

A.3 Conducted Spurious Emissions

Test Data

ANT 0

802.11b Mode:

| Channel | Measured Max. Out of Band Emission (dBm) | Limit (dBm) | | Verdict |
|---------|--|---------------|-------------------------|---------|
| | | Carrier Level | Calculated 20 dBc Limit | |
| Low | -48.52 | 10.11 | -9.89 | Pass |
| Middle | -48.36 | 11.47 | -8.53 | Pass |
| High | -49.21 | 11.27 | -8.73 | Pass |

802.11g Mode:

| Channel | Measured Max. Out of Band Emission (dBm) | Limit (dBm) | | Verdict |
|---------|--|---------------|-------------------------|---------|
| | | Carrier Level | Calculated 20 dBc Limit | |
| Low | -55.17 | 4.42 | -15.58 | Pass |
| Middle | -55.22 | 9.05 | -10.95 | Pass |
| High | -55.50 | 8.92 | -11.08 | Pass |

802.11n-20MHz Mode:

| Channel | Measured Max. Out of Band Emission (dBm) | Limit (dBm) | | Verdict |
|---------|--|---------------|-------------------------|---------|
| | | Carrier Level | Calculated 20 dBc Limit | |
| Low | -54.55 | 3.15 | -16.85 | Pass |
| Middle | -55.12 | 8.45 | -11.55 | Pass |
| High | -53.38 | 11.31 | -8.69 | Pass |

802.11n-40MHz Mode:

| Channel | Measured Max. Out of Band Emission (dBm) | Limit (dBm) | | Verdict |
|---------|--|---------------|-------------------------|---------|
| | | Carrier Level | Calculated 20 dBc Limit | |
| Low | -55.37 | 0.20 | -19.80 | Pass |
| Middle | -55.53 | 9.67 | -10.33 | Pass |
| High | -54.72 | 3.97 | -16.03 | Pass |

ANT 1
802.11b Mode:

| Channel | Measured Max. Out of Band Emission (dBm) | Limit (dBm) | | Verdict |
|---------|--|---------------|-------------------------|---------|
| | | Carrier Level | Calculated 20 dBc Limit | |
| Low | -35.98 | 9.93 | -10.07 | Pass |
| Middle | -36.49 | 9.53 | -10.47 | Pass |
| High | -32.68 | 9.87 | -10.13 | Pass |

802.11g Mode:

| Channel | Measured Max. Out of Band Emission (dBm) | Limit (dBm) | | Verdict |
|---------|--|---------------|-------------------------|---------|
| | | Carrier Level | Calculated 20 dBc Limit | |
| Low | -50.96 | 2.81 | -17.19 | Pass |
| Middle | -47.07 | 8.51 | -11.49 | Pass |
| High | -45.69 | 8.75 | -11.25 | Pass |

802.11n-20MHz Mode:

| Channel | Measured Max. Out of Band Emission (dBm) | Limit (dBm) | | Verdict |
|---------|--|---------------|-------------------------|---------|
| | | Carrier Level | Calculated 20 dBc Limit | |
| Low | -51.25 | 2.63 | -17.37 | Pass |
| Middle | -44.79 | 8.64 | -11.36 | Pass |
| High | -41.71 | 9.19 | -10.81 | Pass |

802.11n-40MHz Mode:

| Channel | Measured Max. Out of Band Emission (dBm) | Limit (dBm) | | Verdict |
|---------|--|---------------|-------------------------|---------|
| | | Carrier Level | Calculated 20 dBc Limit | |
| Low | -49.77 | -0.86 | -20.86 | Pass |
| Middle | -47.97 | 9.35 | -10.65 | Pass |
| High | -51.25 | 2.74 | -17.26 | Pass |

Test Plots

ANT 0

802.11b LOW CHANNEL CARRIER LEVEL

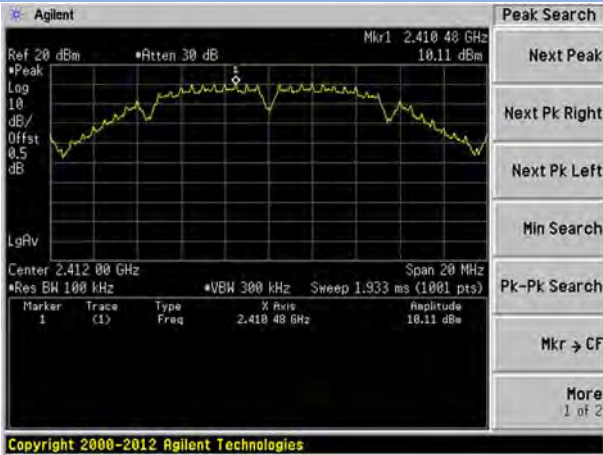

802.11b LOW CHANNEL, SPURIOUS 30 MHz ~ 3 GHz

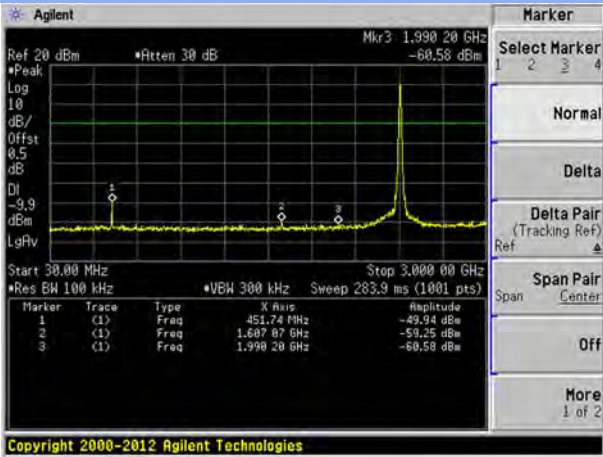

802.11b LOW CHANNEL, SPURIOUS 2 GHz ~ 25 GHz

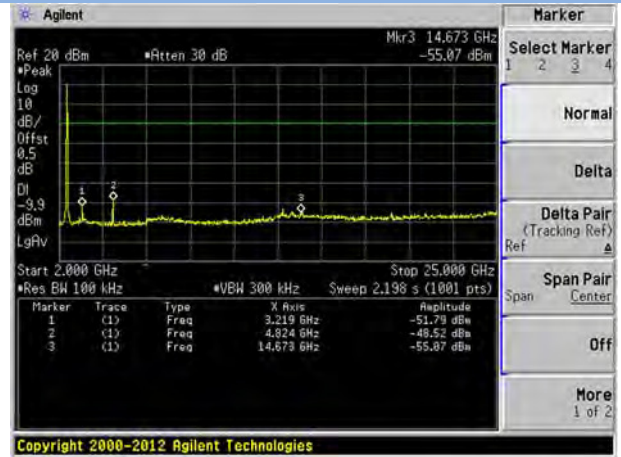

802.11b MIDDLE CHANNEL CARRIER LEVEL

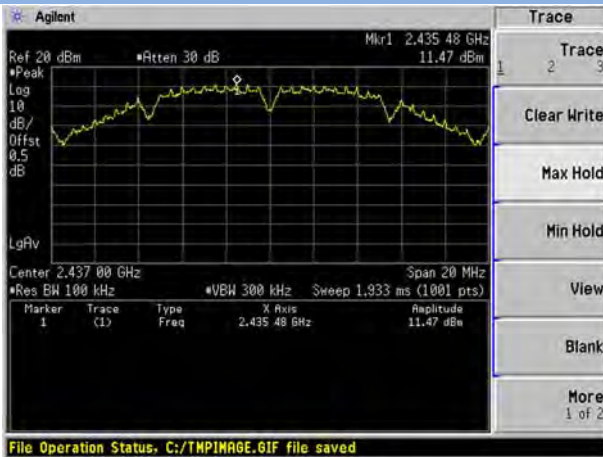

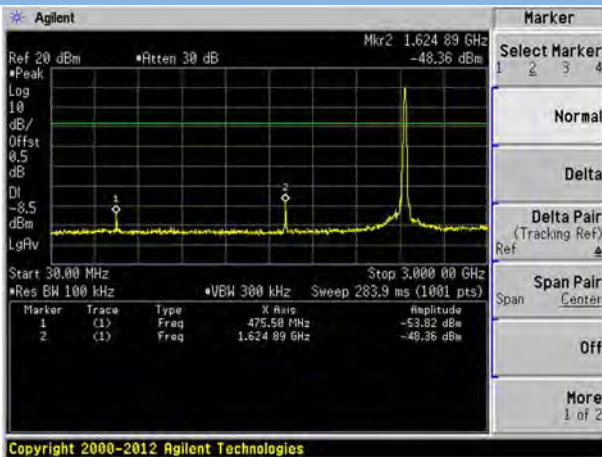
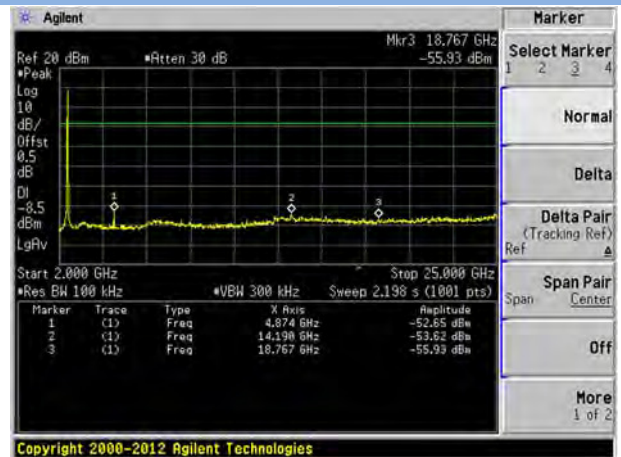
802.11b MIDDLE CHANNEL, SPURIOUS
 30 MHz ~ 3 GHz

 802.11b MIDDLE CHANNEL, SPURIOUS
 2 GHz ~ 25 GHz

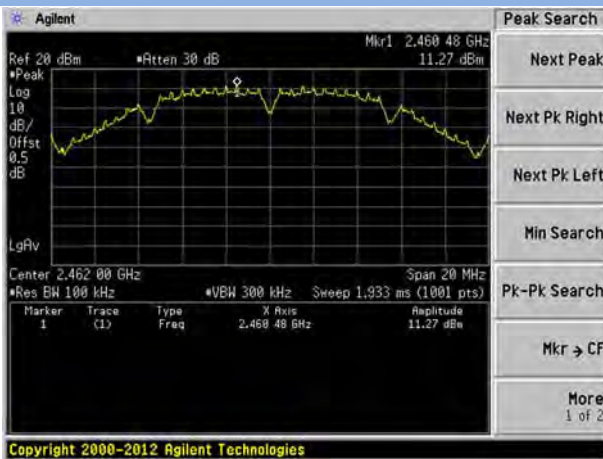
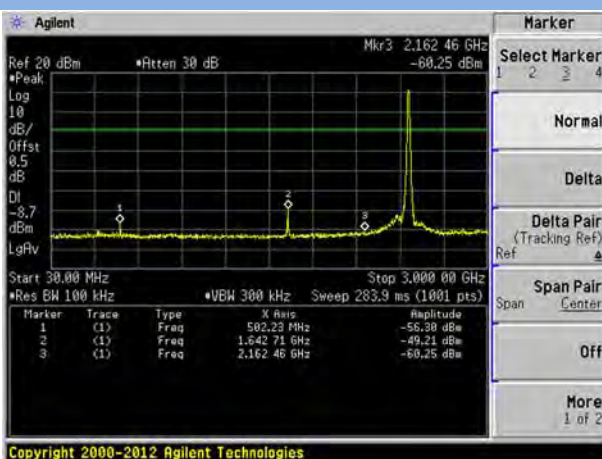
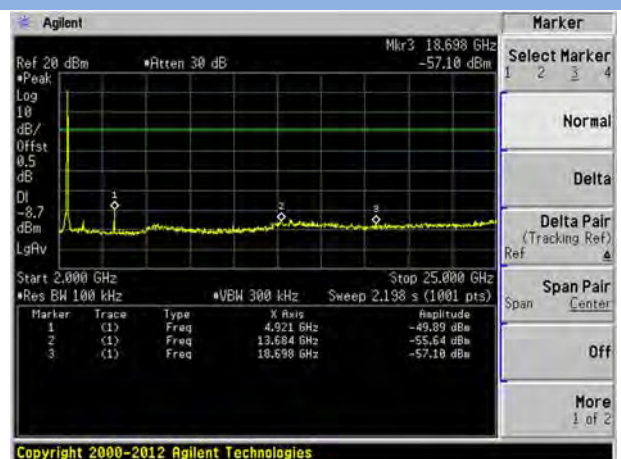
802.11b HIGH CHANNEL CARRIER LEVEL

 802.11b HIGH CHANNEL, SPURIOUS
 30 MHz ~ 3 GHz

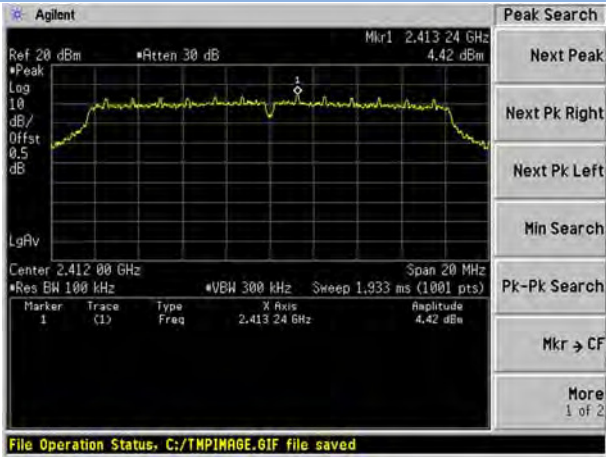
 802.11b HIGH CHANNEL, SPURIOUS
 2 GHz ~ 25 GHz

802.11g LOW CHANNEL CARRIER LEVEL

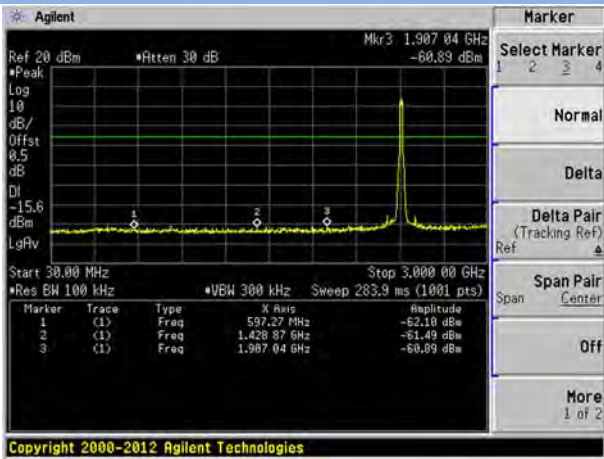

802.11g LOW CHANNEL, SPURIOUS 30 MHz ~ 3 GHz



802.11g LOW CHANNEL, SPURIOUS 2 GHz ~ 25 GHz

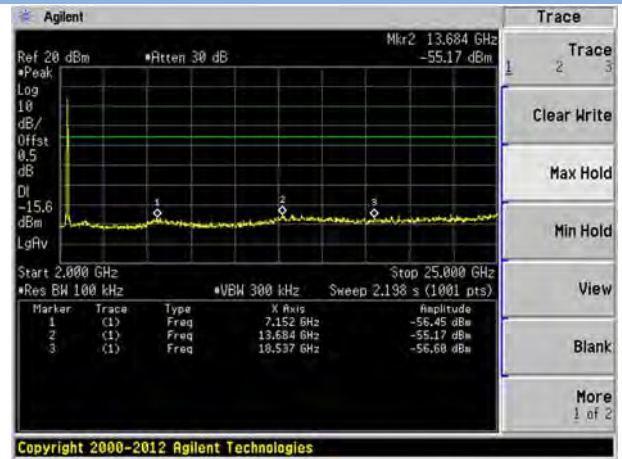

802.11g MIDDLE CHANNEL CARRIER LEVEL

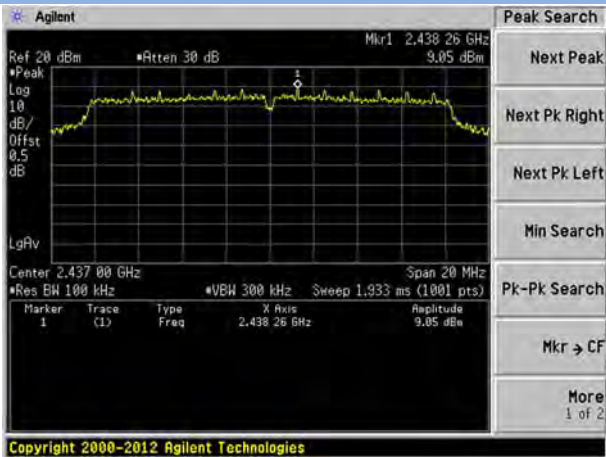

802.11g MIDDLE CHANNEL, SPURIOUS
30 MHz ~ 3 GHz

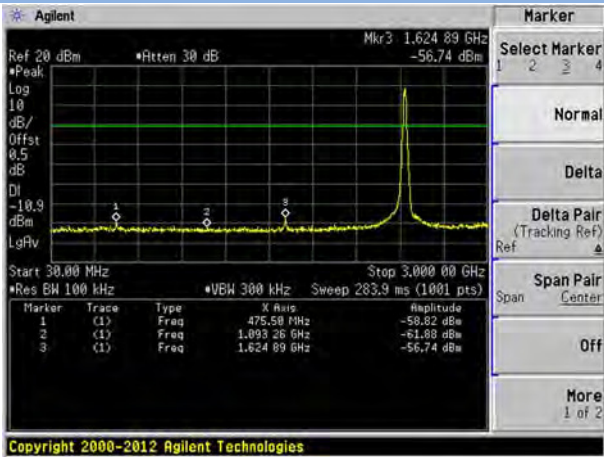

802.11g MIDDLE CHANNEL, SPURIOUS
2 GHz ~ 25 GHz

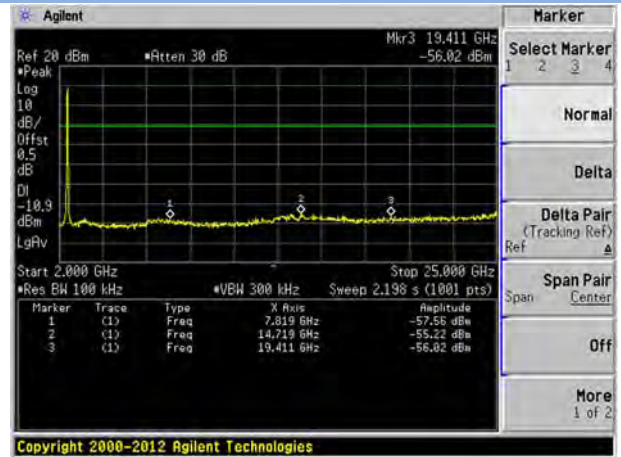

802.11g HIGH CHANNEL CARRIER LEVEL

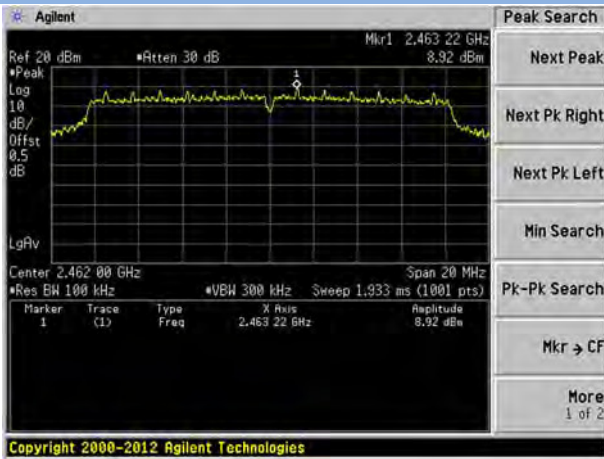

802.11g HIGH CHANNEL, SPURIOUS
30 MHz ~ 3 GHz

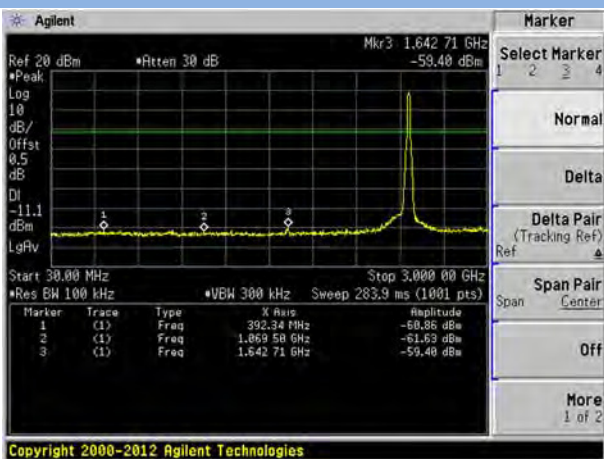

802.11g HIGH CHANNEL, SPURIOUS
2 GHz ~ 25 GHz

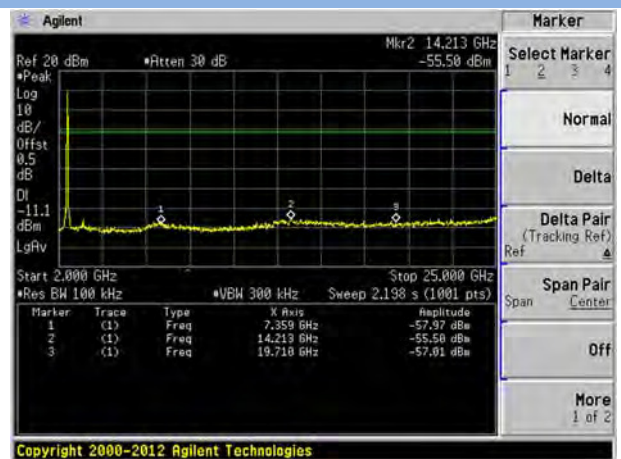

802.11n-20 MHz LOW CHANNEL CARRIER LEVEL

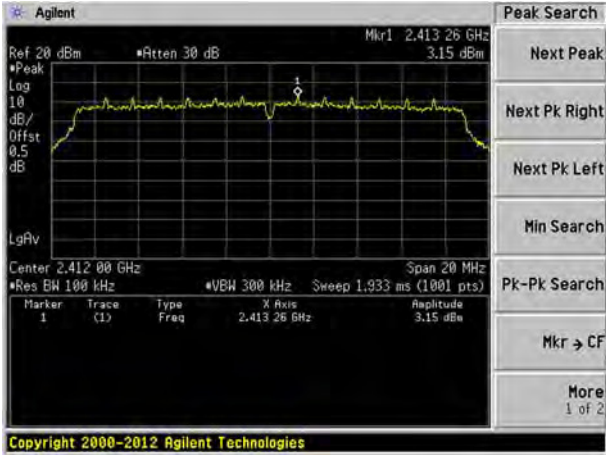

802.11n-20 MHz LOW CHANNEL, SPURIOUS 30 MHz ~ 3 GHz

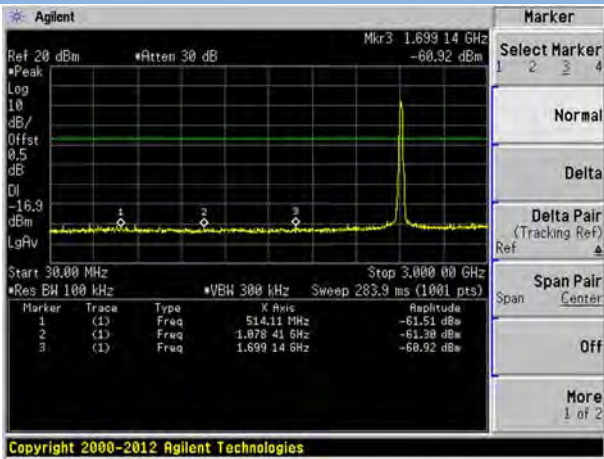

802.11n-20 MHz LOW CHANNEL, SPURIOUS 2 GHz ~ 25 GHz

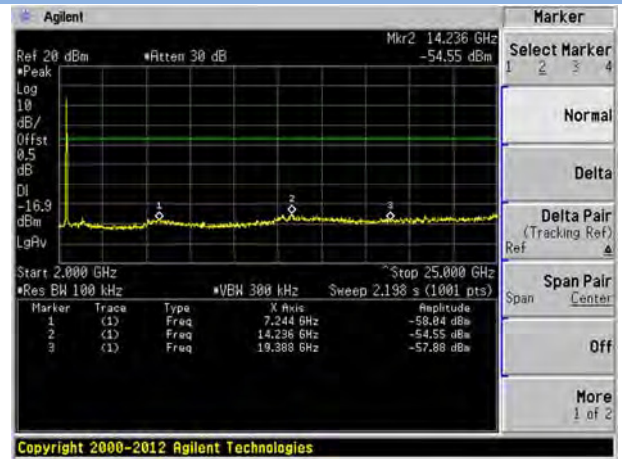

802.11n-20 MHz MIDDLE CHANNEL CARRIER LEVEL

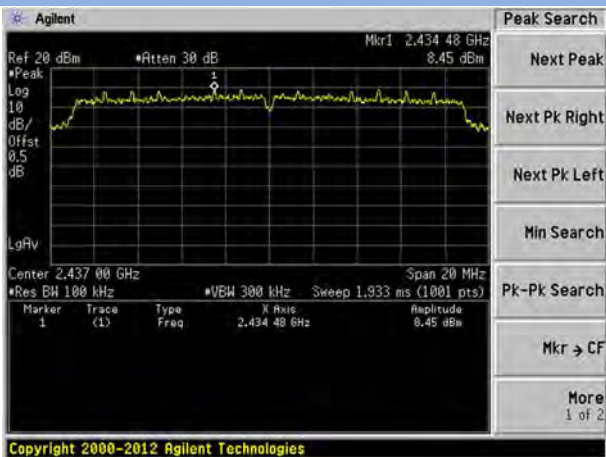

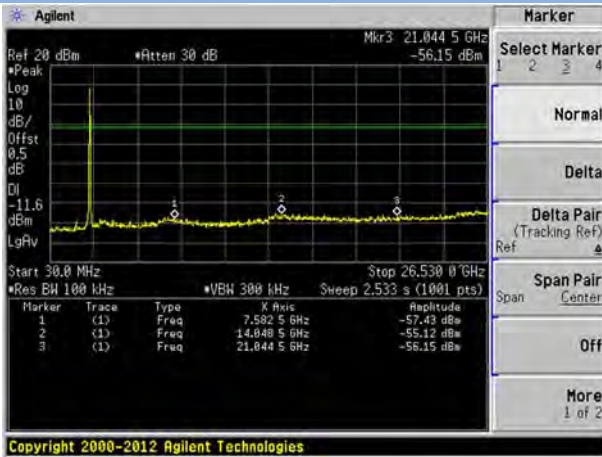
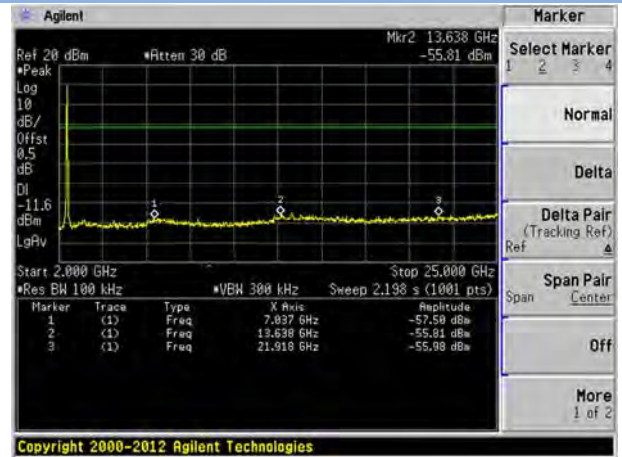
802.11n-20 MHz MIDDLE CHANNEL, SPURIOUS
 30 MHz ~ 3 GHz

 802.11n-20 MHz MIDDLE CHANNEL, SPURIOUS
 2 GHz ~ 25 GHz

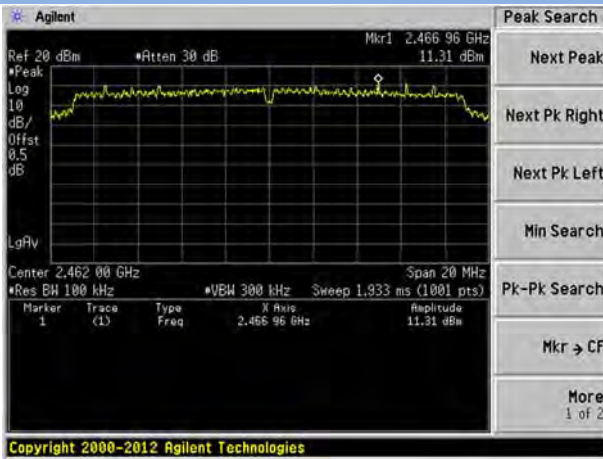
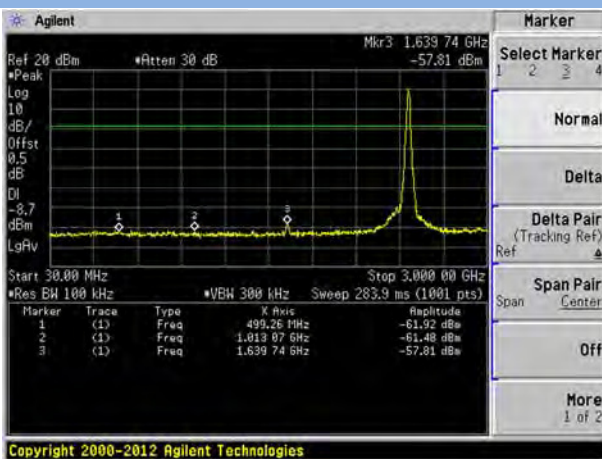
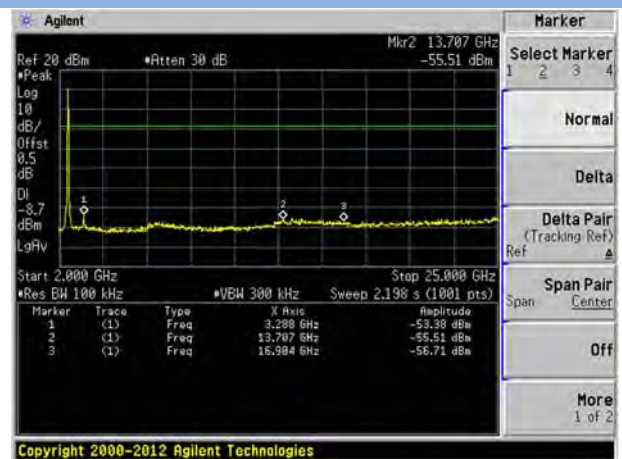
802.11n-20 MHz HIGH CHANNEL CARRIER LEVEL

 802.11n-20 MHz HIGH CHANNEL, SPURIOUS
 30 MHz ~ 3 GHz

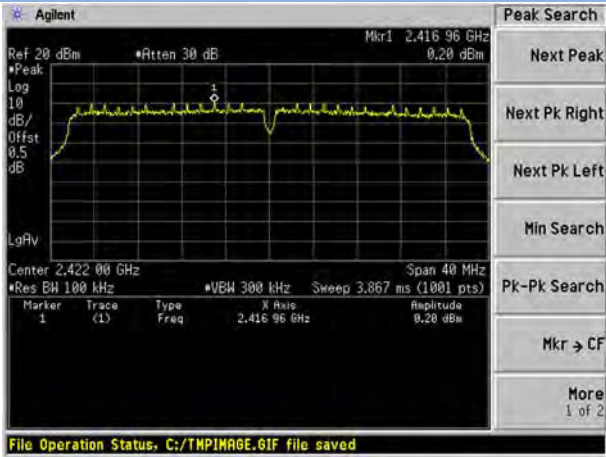
 802.11n-20 MHz HIGH CHANNEL, SPURIOUS
 2 GHz ~ 25 GHz

802.11n-40 MHz LOW CHANNEL CARRIER LEVEL

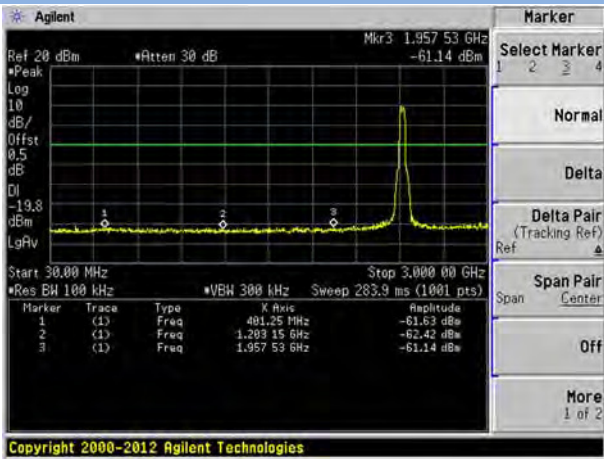

802.11n-40 MHz LOW CHANNEL, SPURIOUS
30 MHz ~ 3 GHz



802.11n-40 MHz LOW CHANNEL, SPURIOUS
2 GHz ~ 25 GHz

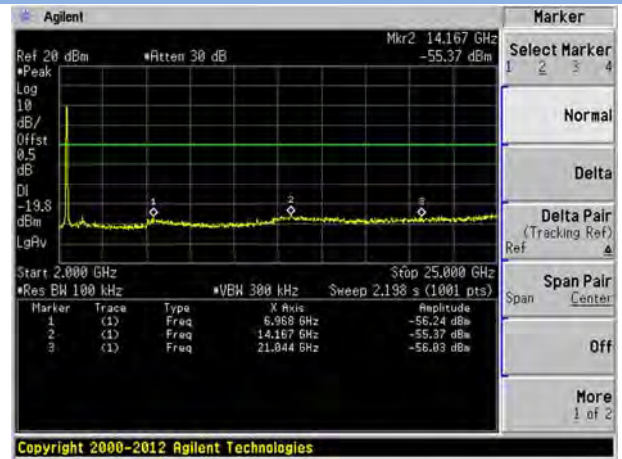

802.11n-40 MHz MIDDLE CHANNEL CARRIER
LEVEL

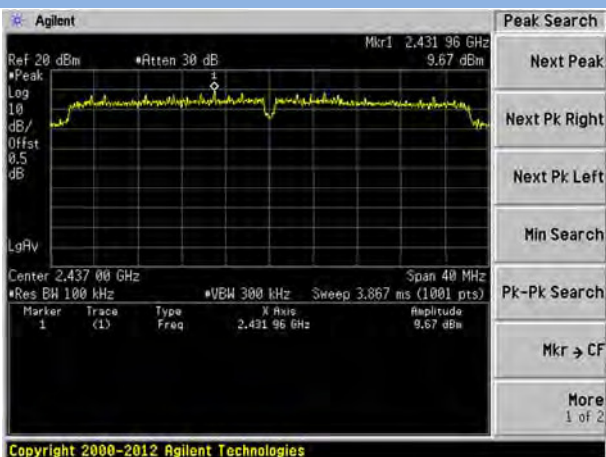

802.11n-40 MHz MIDDLE CHANNEL, SPURIOUS
30 MHz ~ 3 GHz

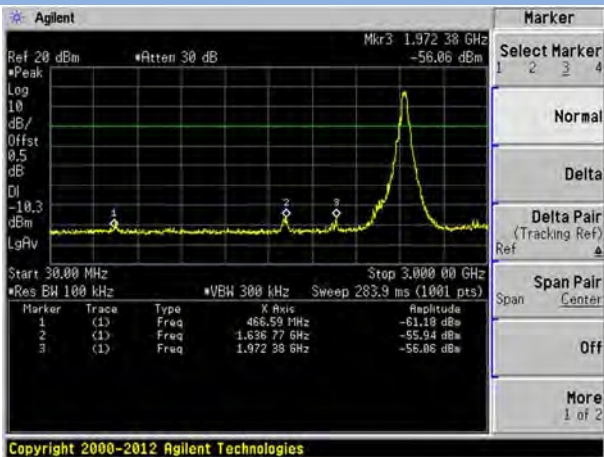

802.11n-40 MHz MIDDLE CHANNEL, SPURIOUS
2 GHz ~ 25 GHz

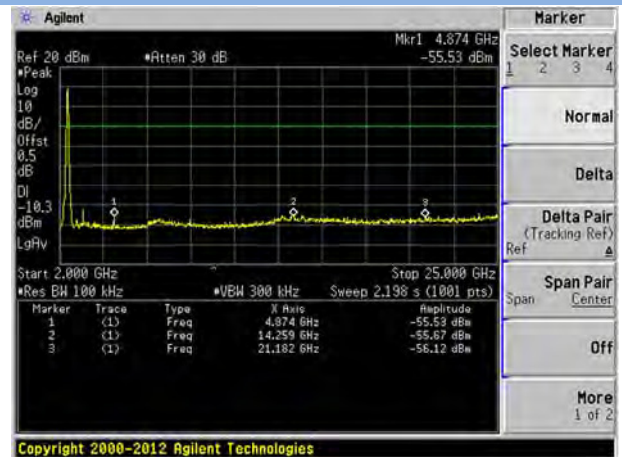

802.11n-40 MHz HIGH CHANNEL CARRIER LEVEL

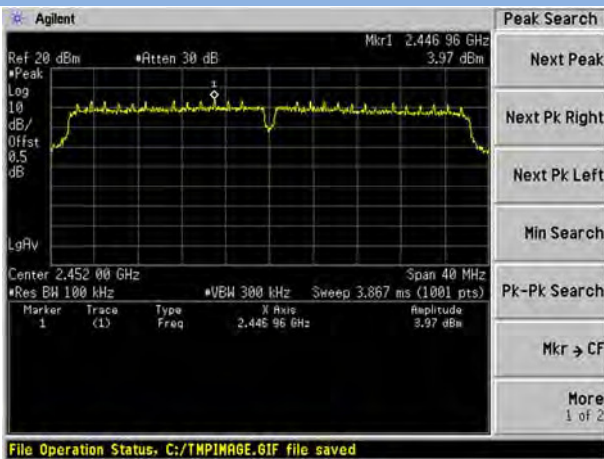

802.11-n40 MHz HIGH CHANNEL, SPURIOUS
30 MHz ~ 3 GHz

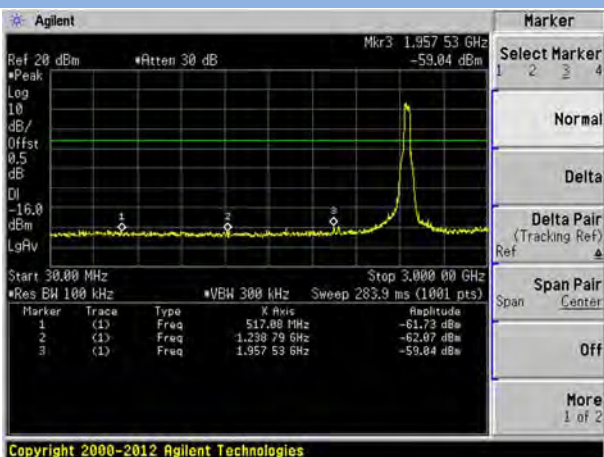

802.11n-40 MHz HIGH CHANNEL, SPURIOUS
2 GHz ~ 25 GHz

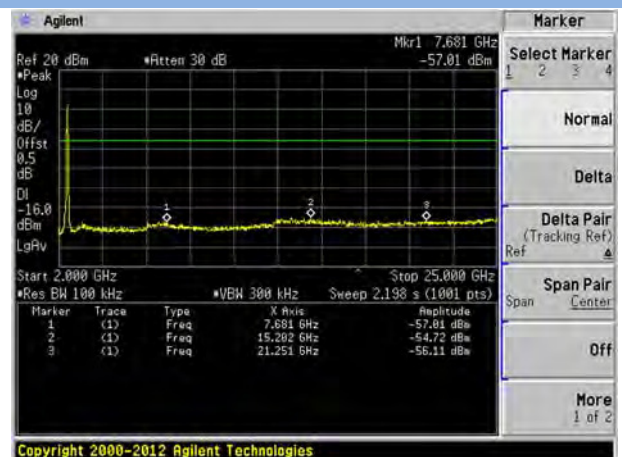

ANT 1

802.11b LOW CHANNEL CARRIER LEVEL

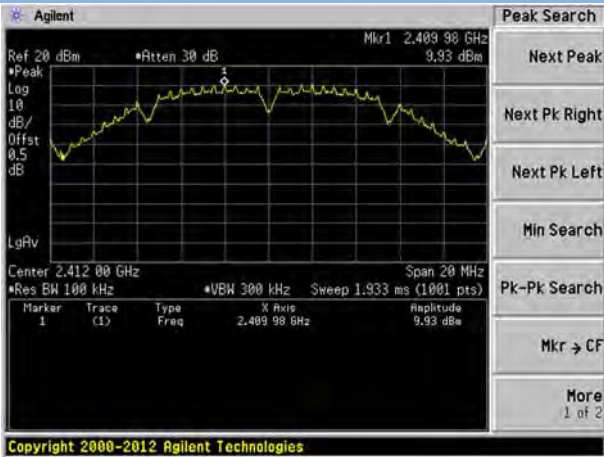

802.11b LOW CHANNEL, SPURIOUS 30 MHz ~ 3 GHz

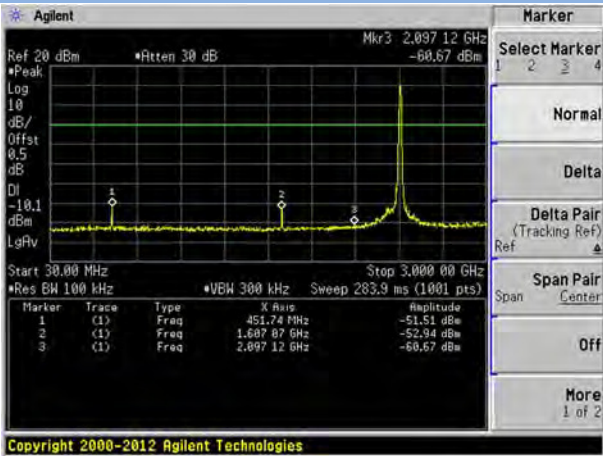

802.11b LOW CHANNEL, SPURIOUS 2 GHz ~ 25 GHz

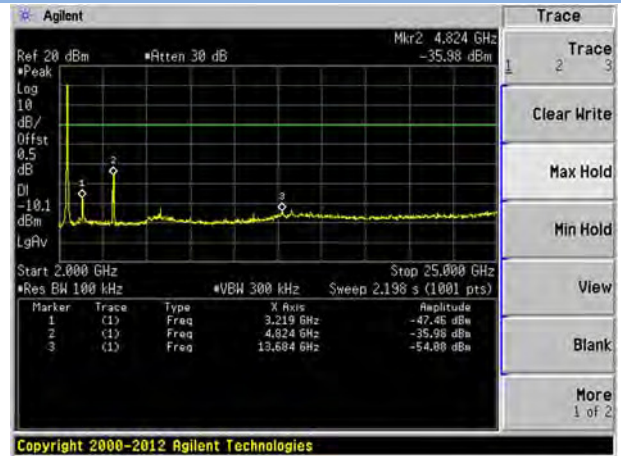

802.11b MIDDLE CHANNEL CARRIER LEVEL

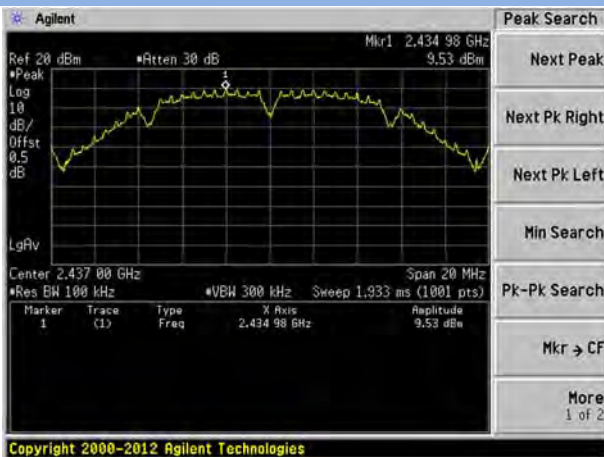

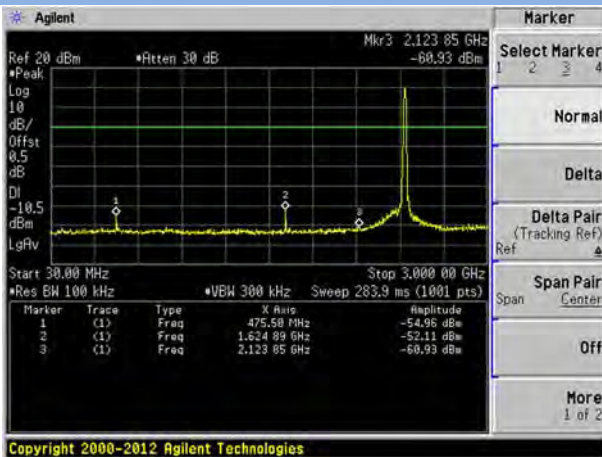
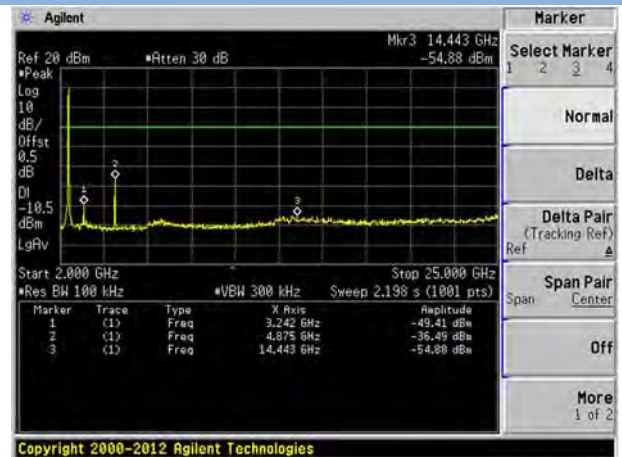
802.11b MIDDLE CHANNEL, SPURIOUS
 30 MHz ~ 3 GHz

 802.11b MIDDLE CHANNEL, SPURIOUS
 2 GHz ~ 25 GHz

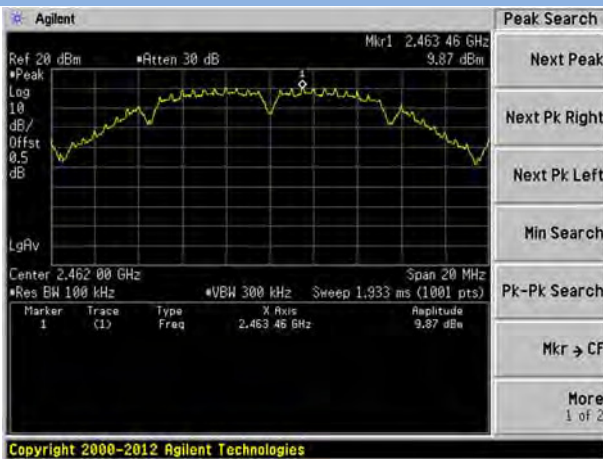
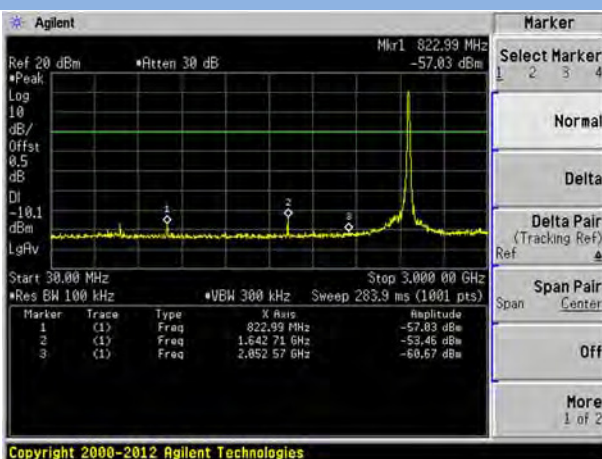
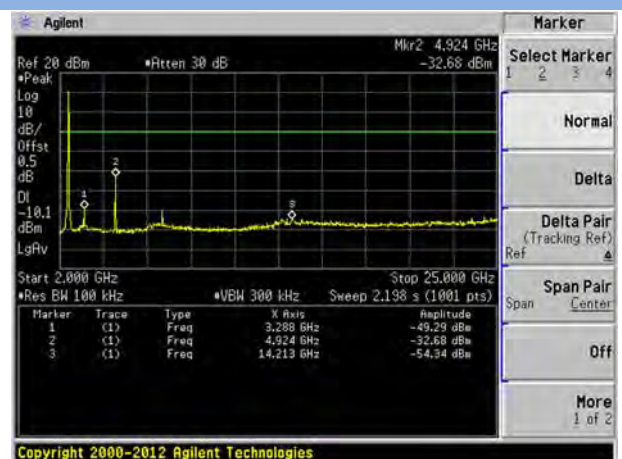
802.11b HIGH CHANNEL CARRIER LEVEL

 802.11b HIGH CHANNEL, SPURIOUS
 30 MHz ~ 3 GHz

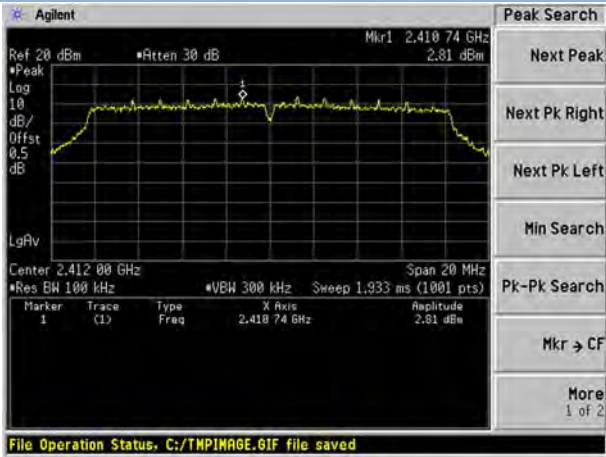
 802.11b HIGH CHANNEL, SPURIOUS
 2 GHz ~ 25 GHz

802.11g LOW CHANNEL CARRIER LEVEL

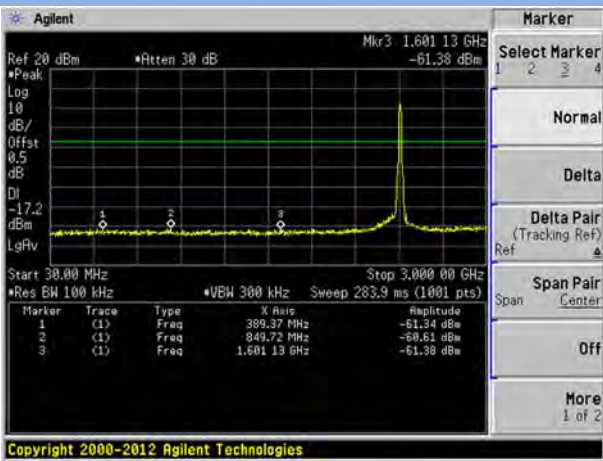

802.11g LOW CHANNEL, SPURIOUS 30 MHz ~ 3 GHz



802.11g LOW CHANNEL, SPURIOUS 2 GHz ~ 25 GHz

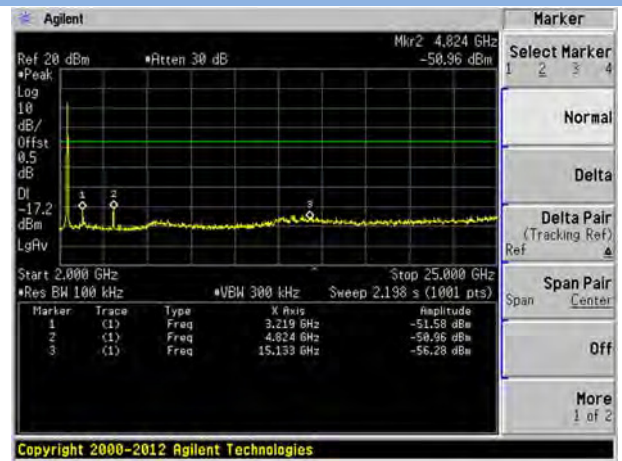

802.11g MIDDLE CHANNEL CARRIER LEVEL

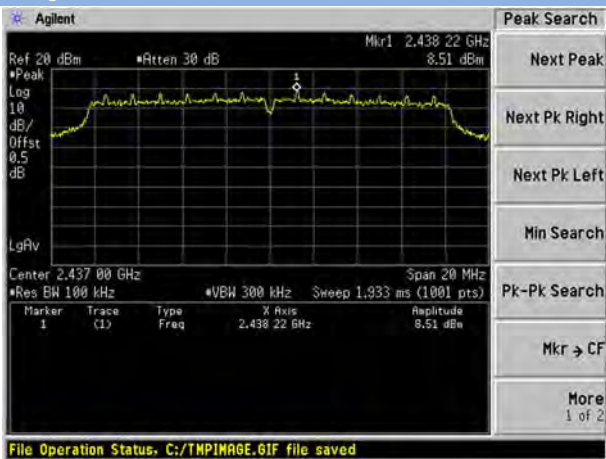

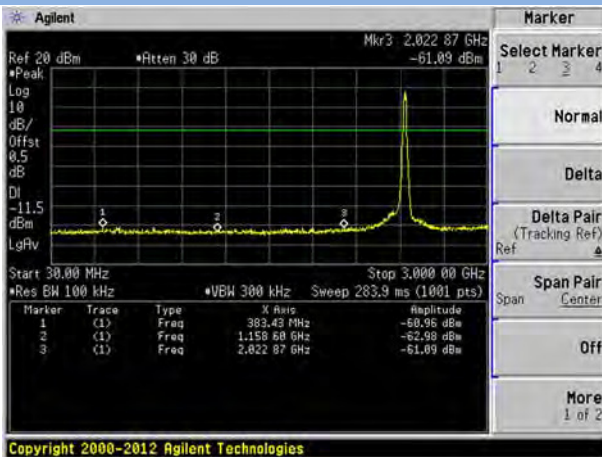
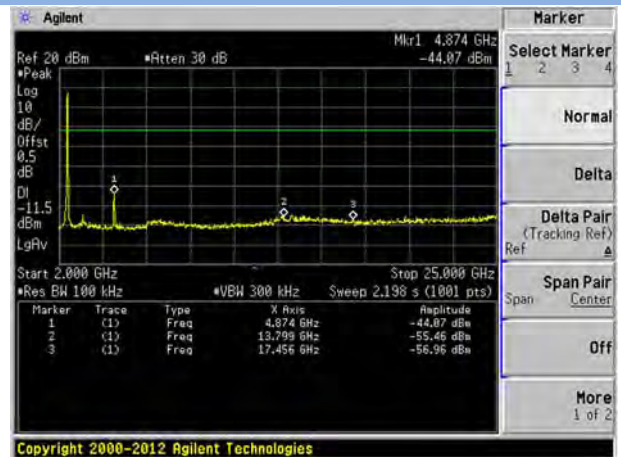
802.11g MIDDLE CHANNEL, SPURIOUS
 30 MHz ~ 3 GHz

 802.11g MIDDLE CHANNEL, SPURIOUS
 2 GHz ~ 25 GHz

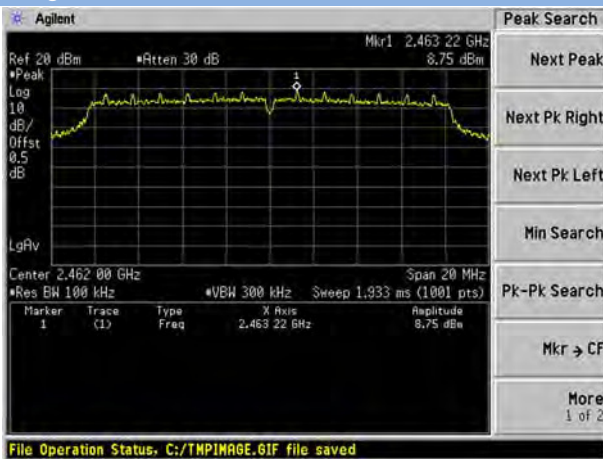
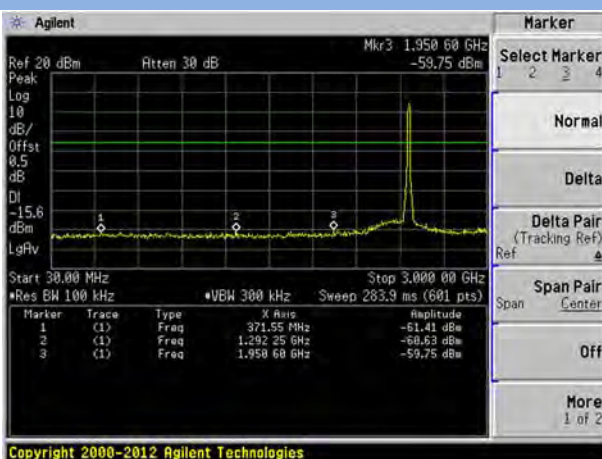
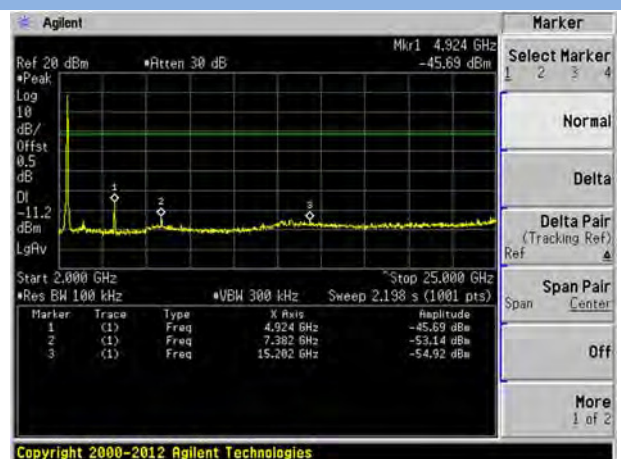
802.11g HIGH CHANNEL CARRIER LEVEL

 802.11g HIGH CHANNEL, SPURIOUS
 30 MHz ~ 3 GHz

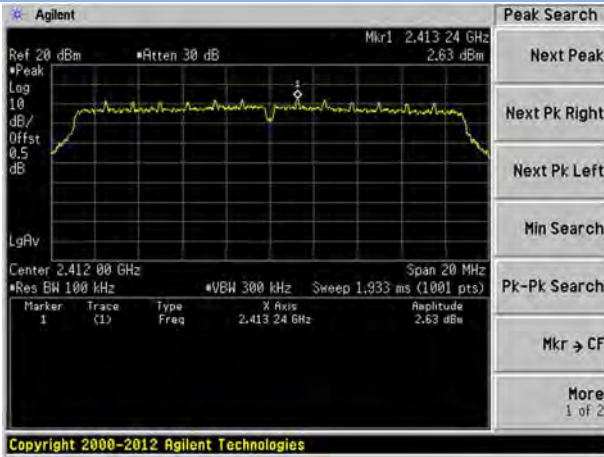
 802.11g HIGH CHANNEL, SPURIOUS
 2 GHz ~ 25 GHz

802.11n-20 MHz LOW CHANNEL CARRIER LEVEL

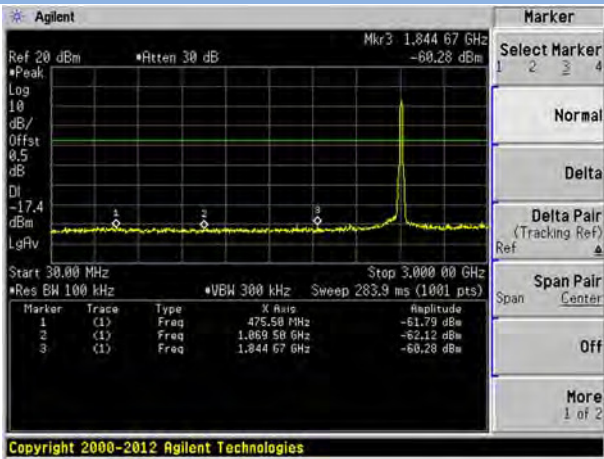

802.11n-20 MHz LOW CHANNEL, SPURIOUS 30 MHz ~ 3 GHz



802.11n-20 MHz LOW CHANNEL, SPURIOUS 2 GHz ~ 25 GHz

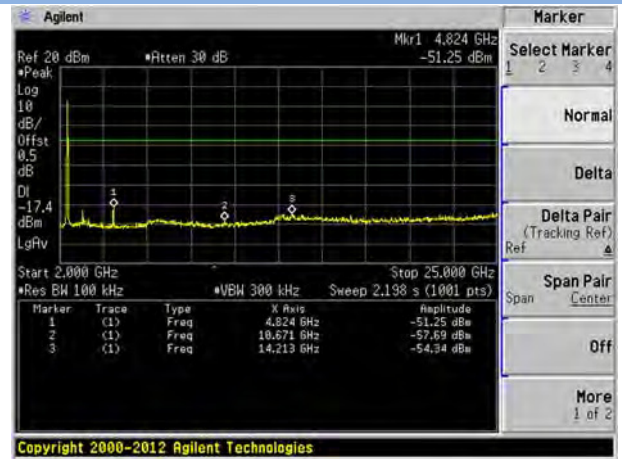

802.11n-20 MHz MIDDLE CHANNEL CARRIER LEVEL

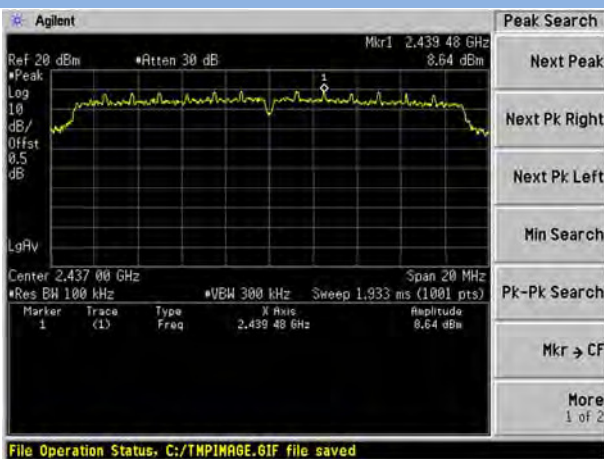

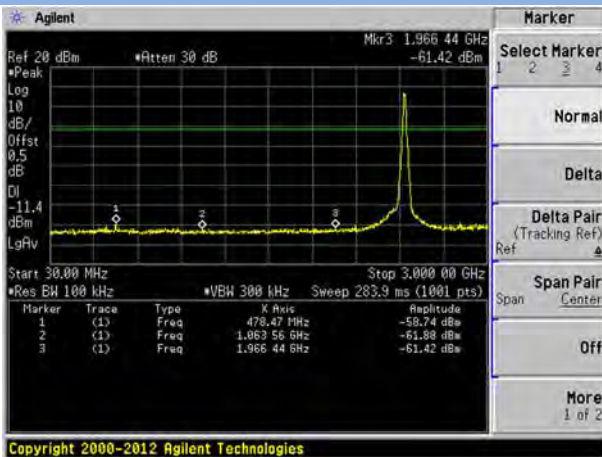
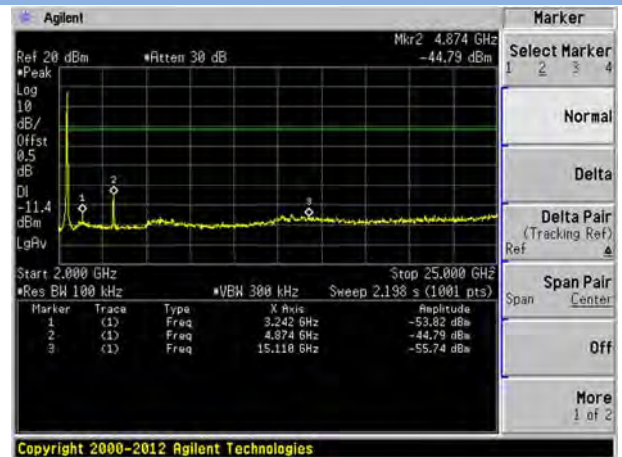
802.11n-20 MHz MIDDLE CHANNEL, SPURIOUS
 30 MHz ~ 3 GHz

 802.11n-20 MHz MIDDLE CHANNEL, SPURIOUS
 2 GHz ~ 25 GHz

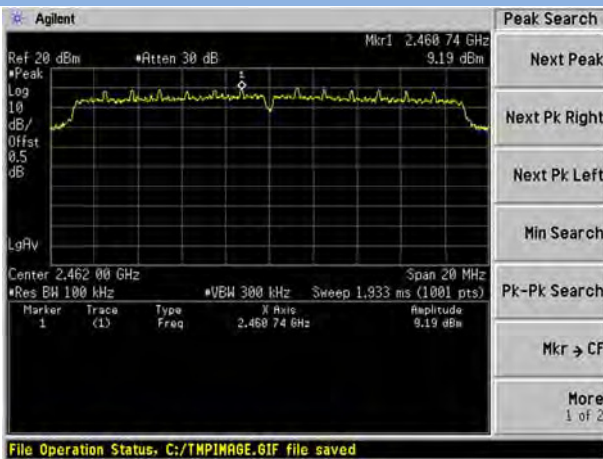
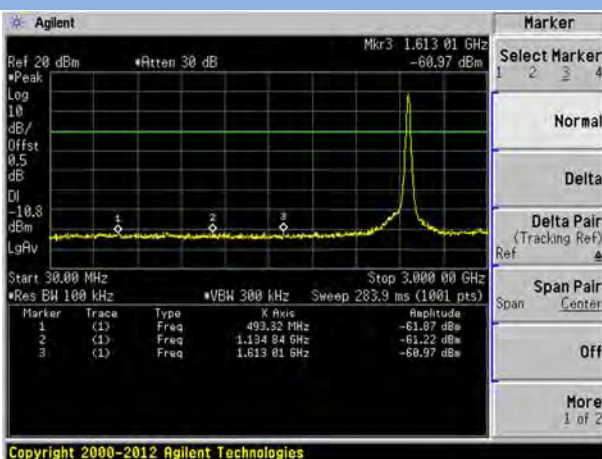
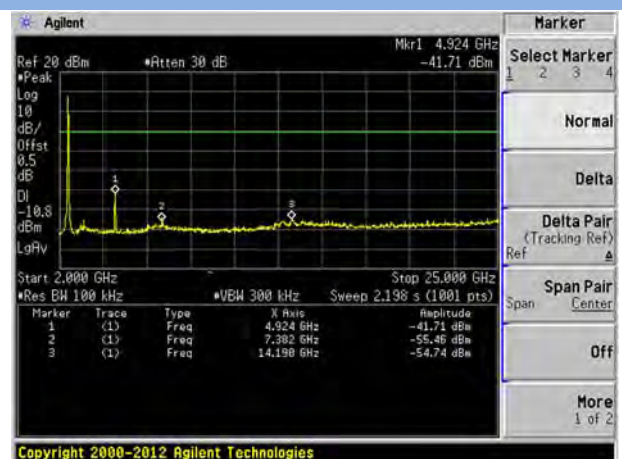
802.11n-20 MHz HIGH CHANNEL CARRIER LEVEL

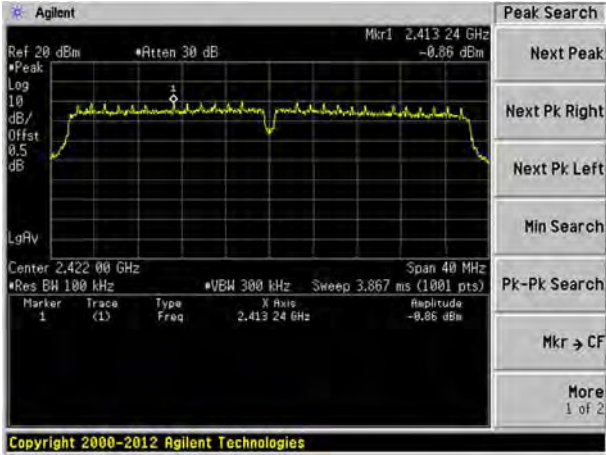
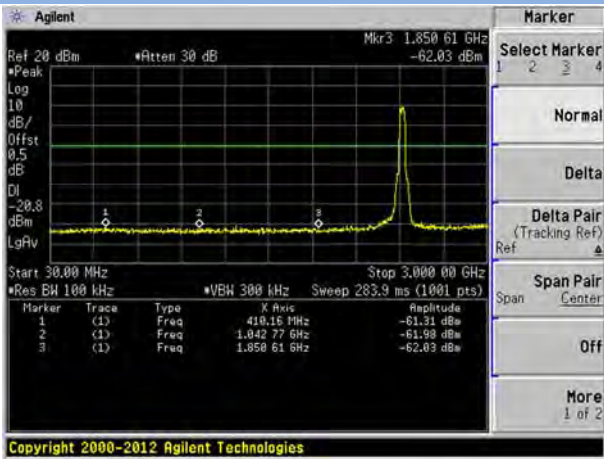
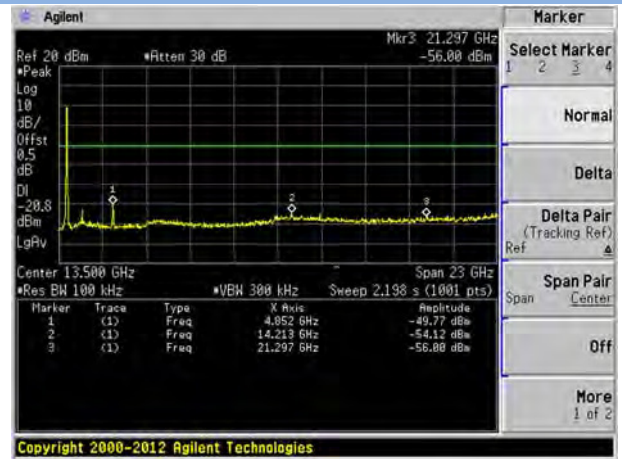
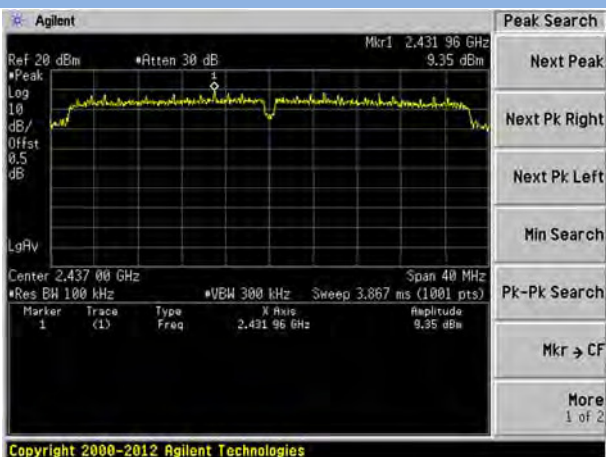

 802.11n-20 MHz HIGH CHANNEL, SPURIOUS
 30 MHz ~ 3 GHz

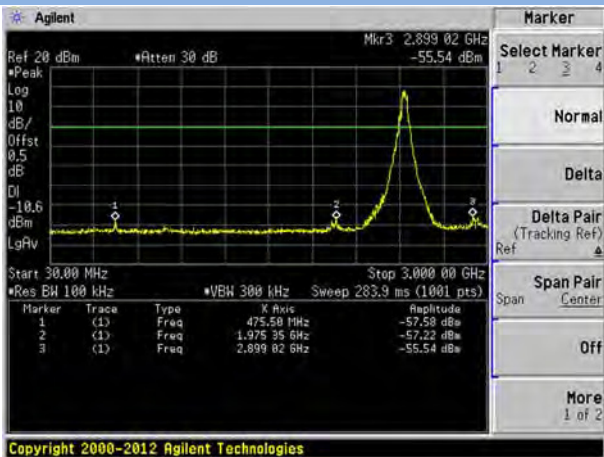
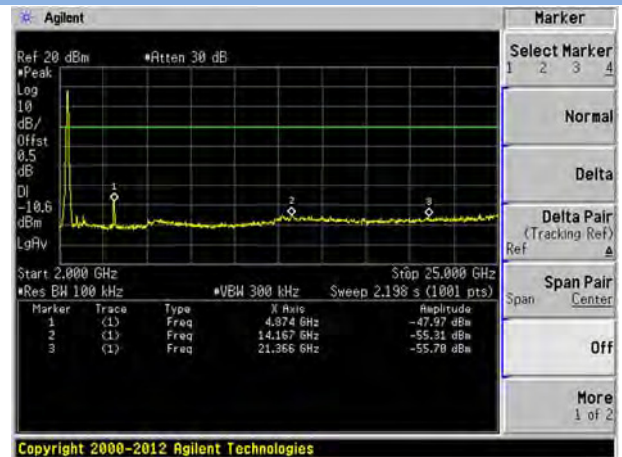
 802.11n-20 MHz HIGH CHANNEL, SPURIOUS
 2 GHz ~ 25 GHz

802.11n-40 MHz LOW CHANNEL CARRIER LEVEL

 802.11n-40 MHz LOW CHANNEL, SPURIOUS
30 MHz ~ 3 GHz

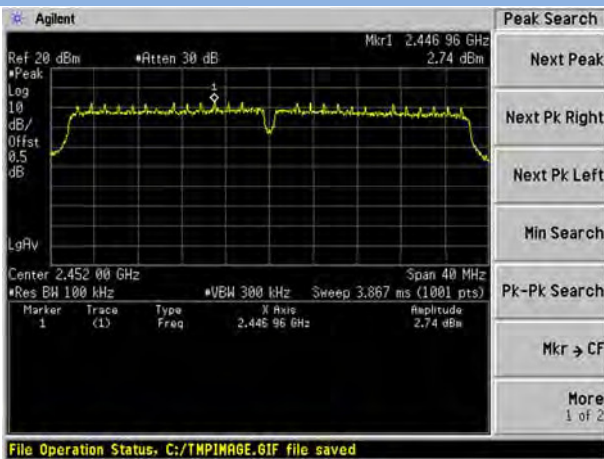
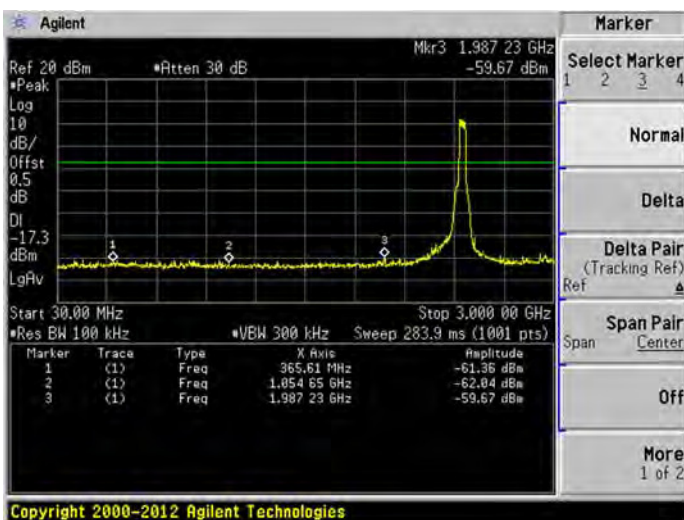
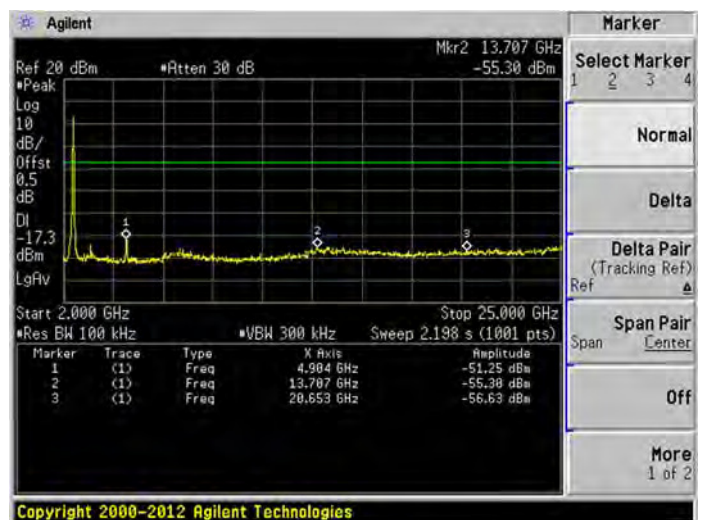
 802.11n-40 MHz LOW CHANNEL, SPURIOUS
2 GHz ~ 25 GHz

 802.11n-40 MHz MIDDLE CHANNEL CARRIER
LEVEL

802.11n-40 MHz MIDDLE CHANNEL, SPURIOUS
 30 MHz ~ 3 GHz

 802.11n-40 MHz MIDDLE CHANNEL, SPURIOUS
 2 GHz ~ 25 GHz

802.11n-40 MHz HIGH CHANNEL CARRIER LEVEL

 802.11n-40 MHz HIGH CHANNEL, SPURIOUS
 30 MHz ~ 3 GHz

 802.11n-40 MHz HIGH CHANNEL, SPURIOUS
 2 GHz ~ 25 GHz

A.4 Band Edge (Authorized-band band-edge)

Note: The lowest and highest channels are tested to verify the band edge emissions. Please refer to the following the plots for emissions values.

Test Data (ANT 0)

802.11b Mode:

| Channel | Measured Max. Band Edge Emission (dBm) | Limit (dBm) | | Verdict |
|--------------|--|---------------|-------------------------|---------|
| | | Carrier Level | Calculated 20 dBc Limit | |
| Low Channel | -22.57 | 10.11 | -9.89 | Pass |
| High Channel | -23.23 | 11.27 | -8.73 | Pass |

802.11g Mode:

| Channel | Measured Max. Band Edge Emission (dBm) | Limit (dBm) | | Verdict |
|--------------|--|---------------|-------------------------|---------|
| | | Carrier Level | Calculated 20 dBc Limit | |
| Low Channel | -26.16 | 4.42 | -15.58 | Pass |
| High Channel | -26.07 | 8.92 | -11.08 | Pass |

802.11n-20 MHz Mode:

| Channel | Measured Max. Band Edge Emission (dBm) | Limit (dBm) | | Verdict |
|--------------|--|---------------|-------------------------|---------|
| | | Carrier Level | Calculated 20 dBc Limit | |
| Low Channel | -30.14 | 3.15 | -16.85 | Pass |
| High Channel | -20.83 | 11.31 | -8.69 | Pass |

802.11n-40 MHz Mode:

| Channel | Measured Max. Band Edge Emission (dBm) | Limit (dBm) | | Verdict |
|--------------|--|---------------|-------------------------|---------|
| | | Carrier Level | Calculated 20 dBc Limit | |
| Low Channel | -30.82 | 0.20 | -19.8 | Pass |
| High Channel | -19.59 | 3.97 | -16.03 | Pass |

Test Data (ANT 1)

802.11b Mode:

| Channel | Measured Max. Band Edge Emission (dBm) | Limit (dBm) | | Verdict |
|--------------|--|---------------|-------------------------|---------|
| | | Carrier Level | Calculated 20 dBc Limit | |
| Low Channel | -23.33 | 9.93 | -10.07 | Pass |
| High Channel | -40.95 | 9.87 | -10.13 | Pass |

802.11g Mode:

| Channel | Measured Max. Band Edge Emission (dBm) | Limit (dBm) | | Verdict |
|--------------|--|---------------|-------------------------|---------|
| | | Carrier Level | Calculated 20 dBc Limit | |
| Low Channel | -26.49 | 2.81 | -17.19 | Pass |
| High Channel | -29.81 | 8.75 | -11.25 | Pass |

802.11n-20 MHz Mode:

| Channel | Measured Max. Band Edge Emission (dBm) | Limit (dBm) | | Verdict |
|--------------|--|---------------|-------------------------|---------|
| | | Carrier Level | Calculated 20 dBc Limit | |
| Low Channel | -28.52 | 2.63 | -17.37 | Pass |
| High Channel | -24.31 | 9.19 | -10.81 | Pass |

802.11n-40 MHz Mode:

| Channel | Measured Max. Band Edge Emission (dBm) | Limit (dBm) | | Verdict |
|--------------|--|---------------|-------------------------|---------|
| | | Carrier Level | Calculated 20 dBc Limit | |
| Low Channel | -31.69 | -0.86 | -20.86 | Pass |
| High Channel | -30.32 | 2.74 | -17.26 | Pass |

Test Plots

ANT 0

802.11b LOW CHANNEL, Carrier level

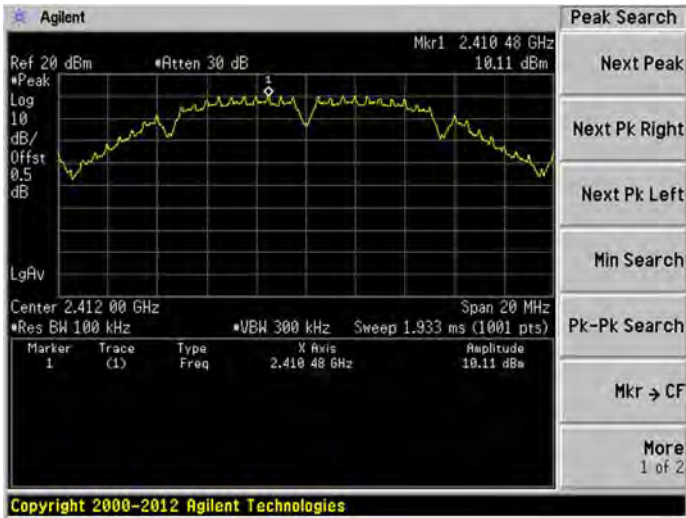

802.11b LOW CHANNEL, Reference level



802.11b LOW CHANNEL, Band Edge

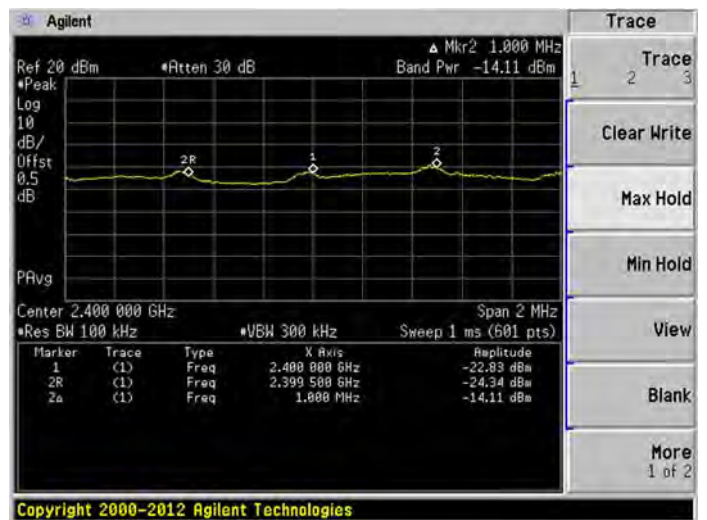

802.11b HIGH CHANNEL, Carrier level

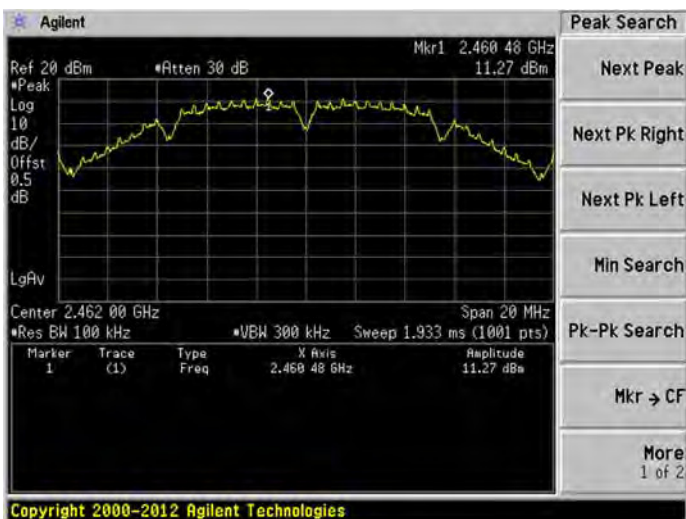

802.11b HIGH CHANNEL, Reference level

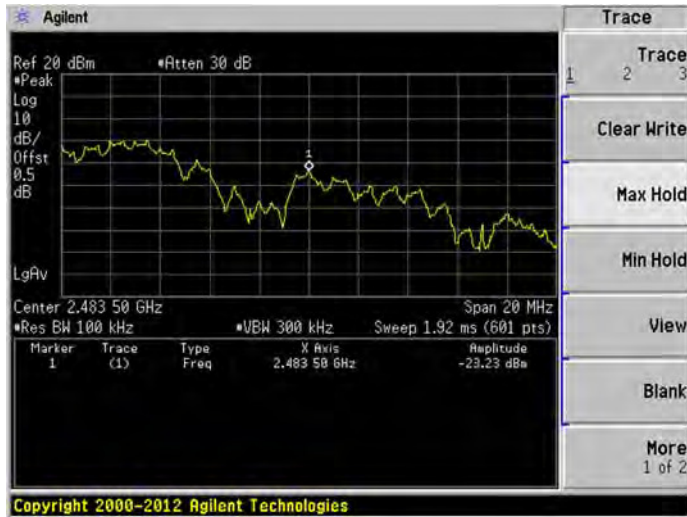

802.11b HIGH CHANNEL, Band Edge

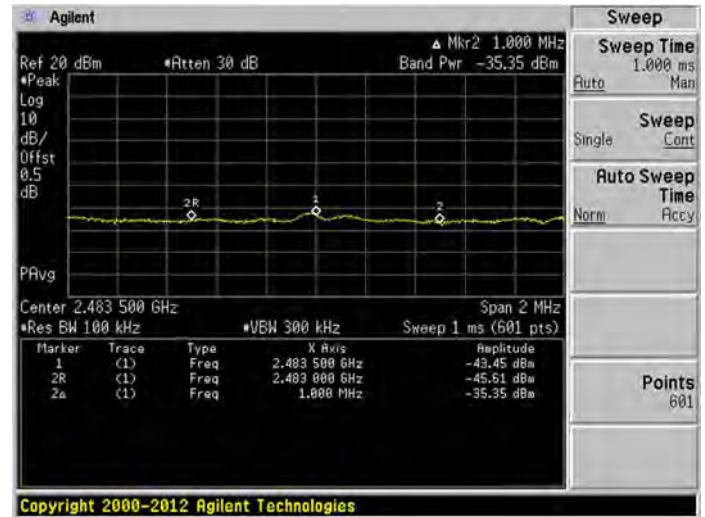

802.11g LOW CHANNEL, Carrier level

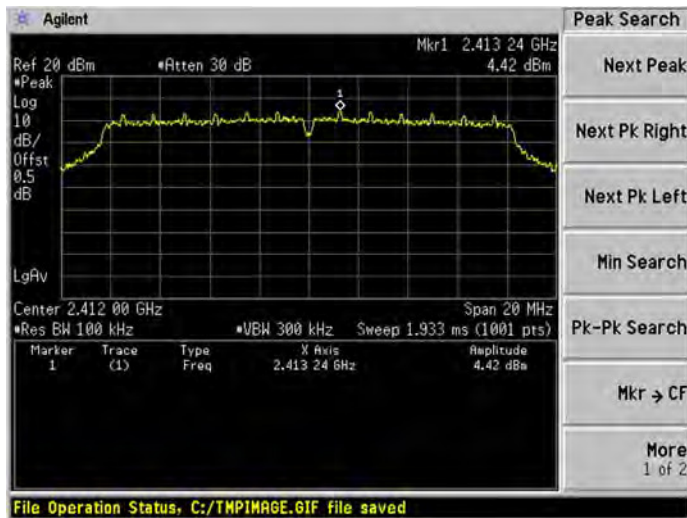

802.11g LOW CHANNEL, Reference level

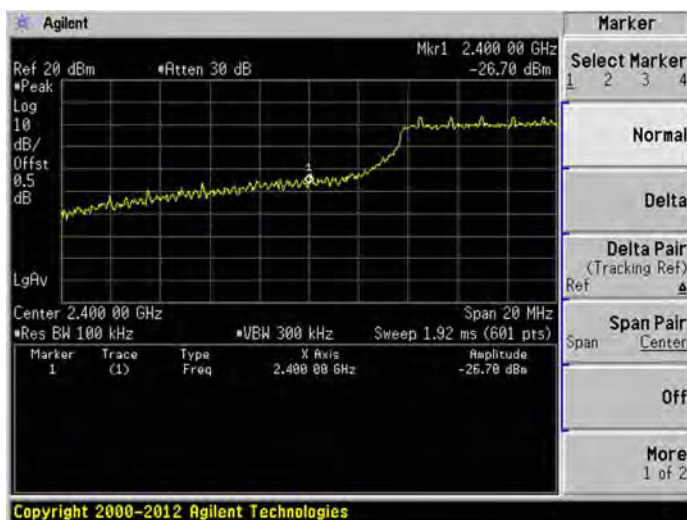

802.11g LOW CHANNEL, Band Edge

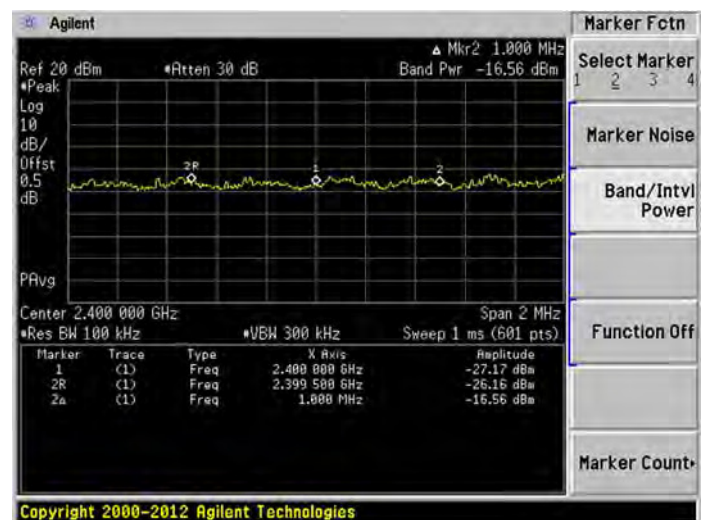

802.11g HIGH CHANNEL, Carrier level

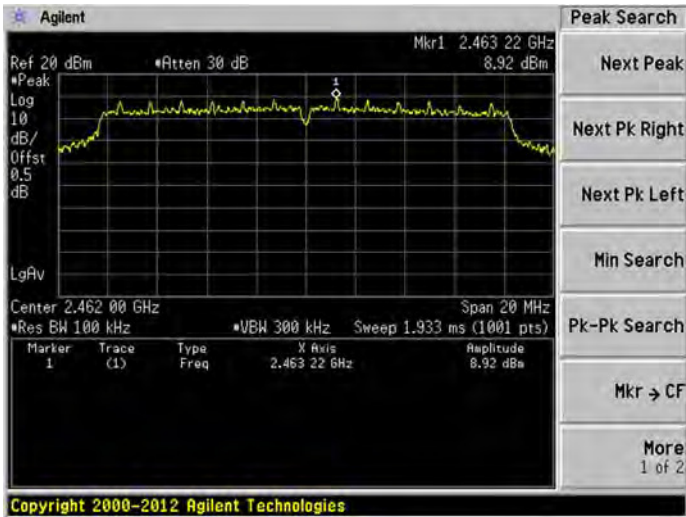

802.11g HIGH CHANNEL, Reference level

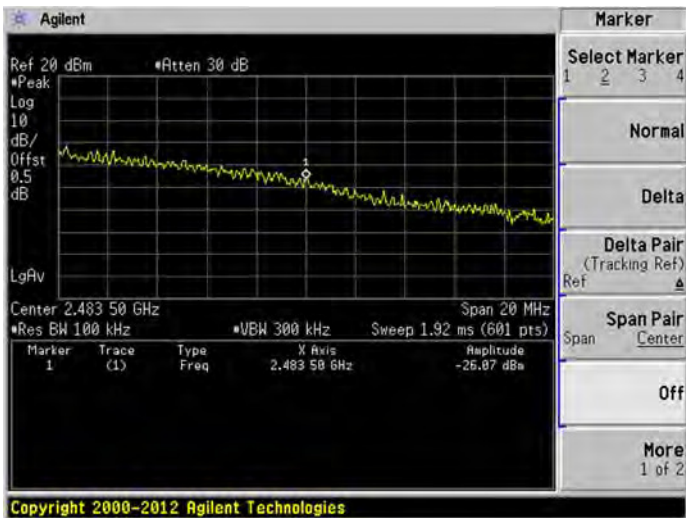

802.11g HIGH CHANNEL, Band Edge

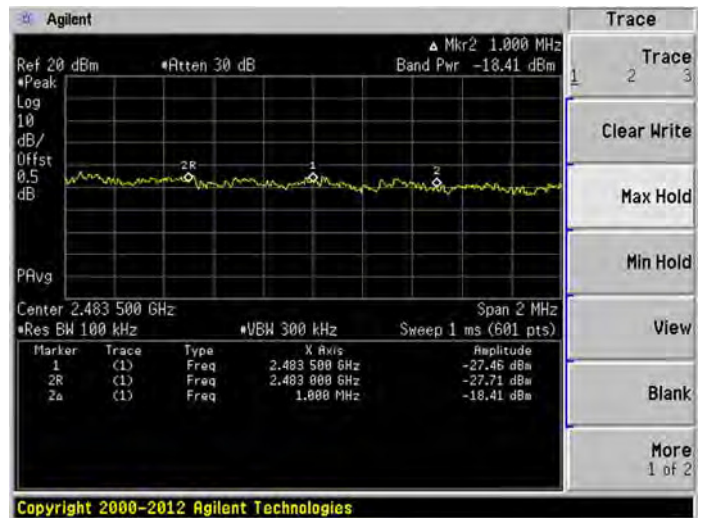

802.11n-20 MHz LOW CHANNEL, Carrier level

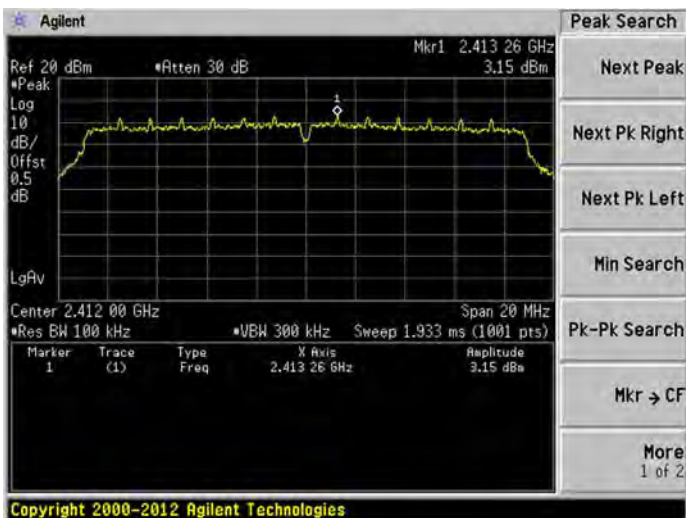

802.11n-20 MHz LOW CHANNEL, Reference level

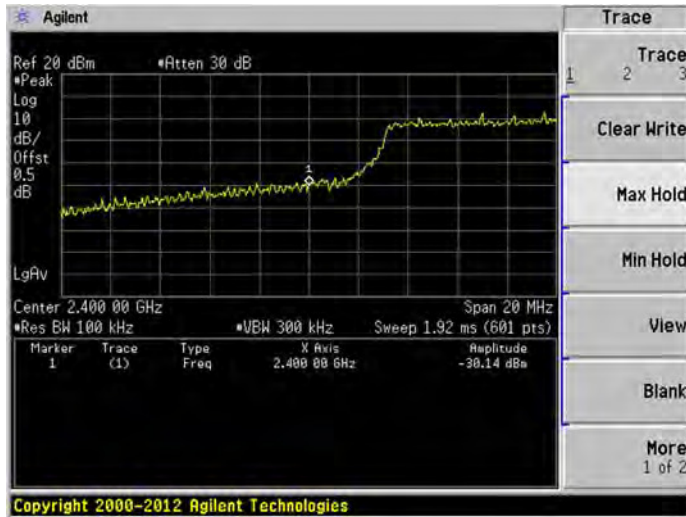

802.11n-20 MHz LOW CHANNEL, Band Edge

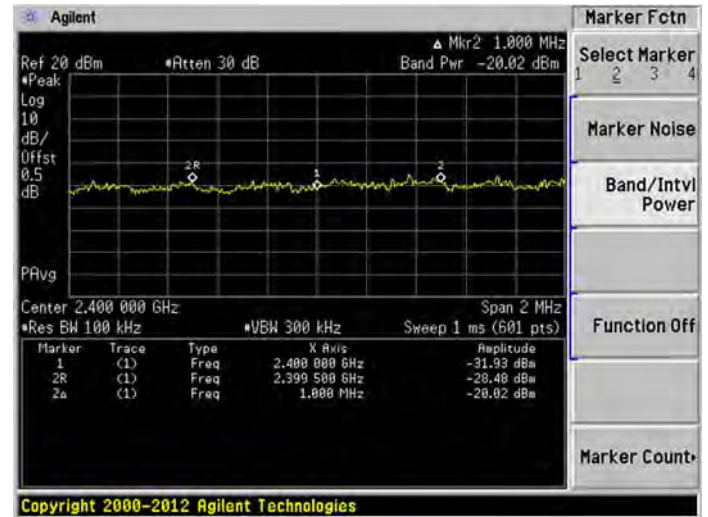

802.11n-20 MHz HIGH CHANNEL, Carrier level

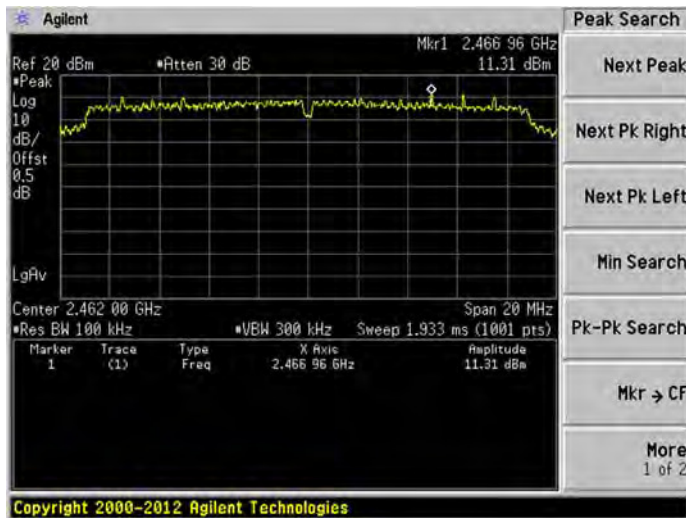

802.11n-20 MHz HIGH CHANNEL, Reference level

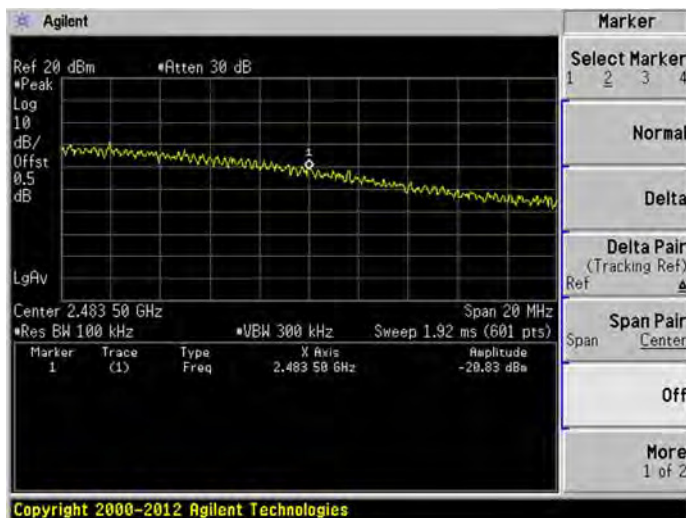

802.11n-20 MHz HIGH CHANNEL, Band Edge

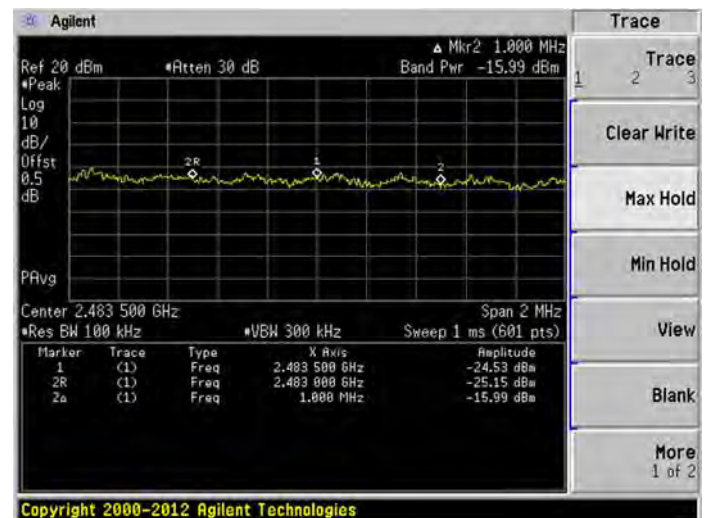

802.11n-40 MHz LOW CHANNEL, Carrier level

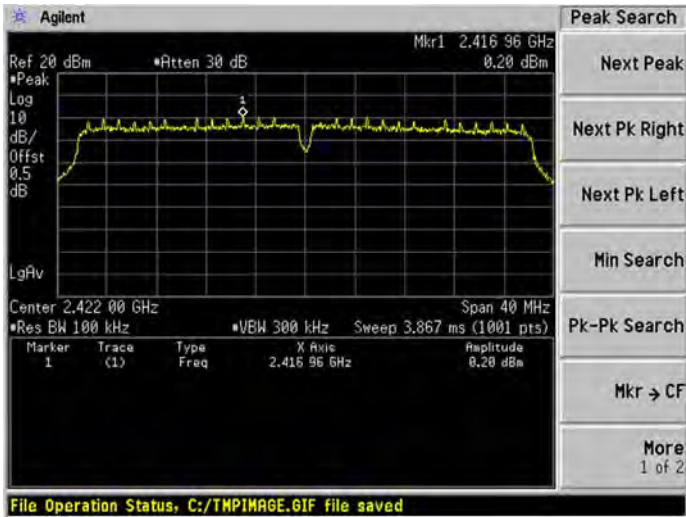

802.11n-40 MHz LOW CHANNEL, Reference level

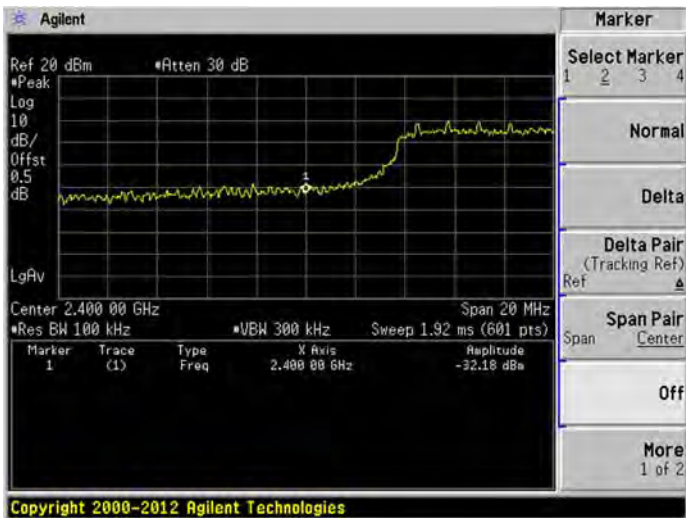

802.11n-40 MHz LOW CHANNEL, Band Edge

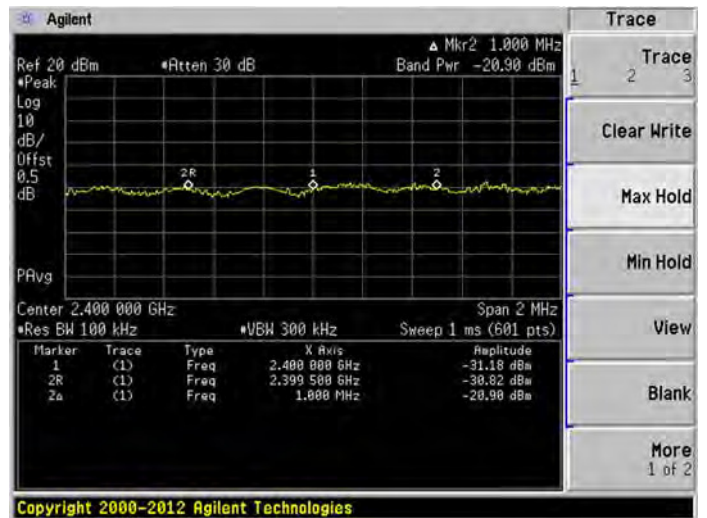

802.11n-40 MHz HIGH CHANNEL, Carrier level

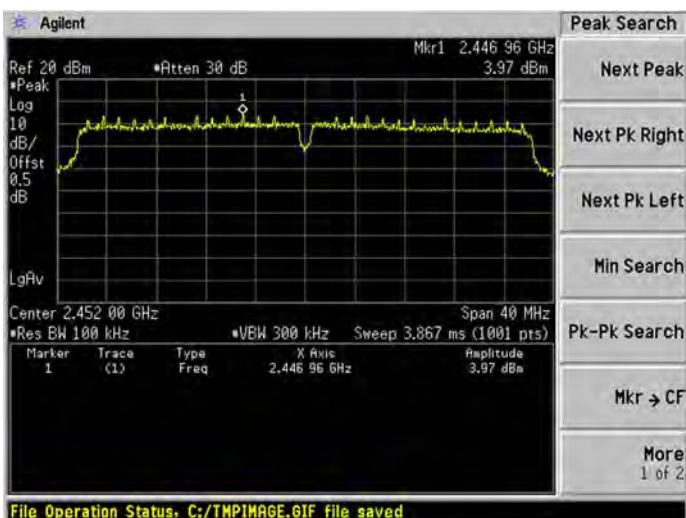

802.11n-40 MHz HIGH CHANNEL, Reference level

802.11n-40 MHz HIGH CHANNEL, Band Edge

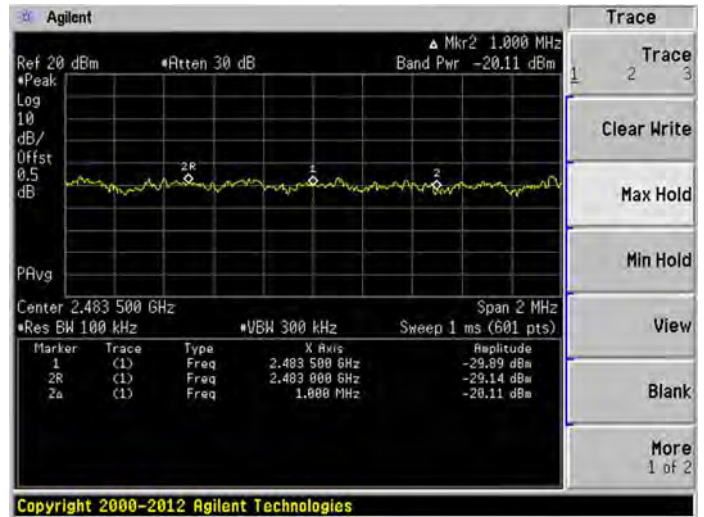
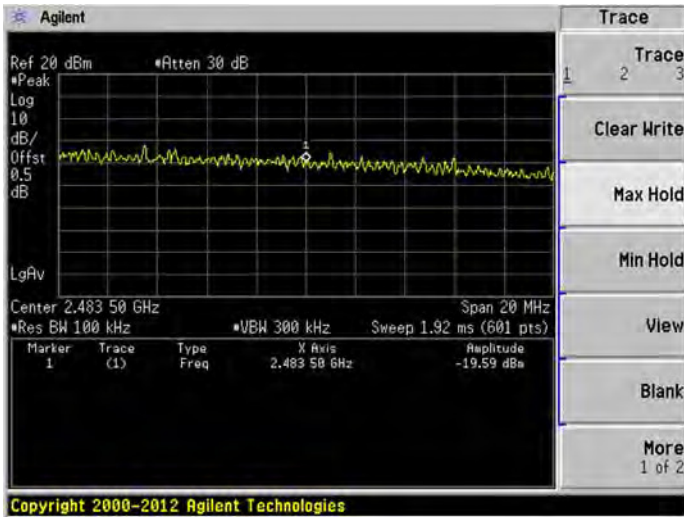

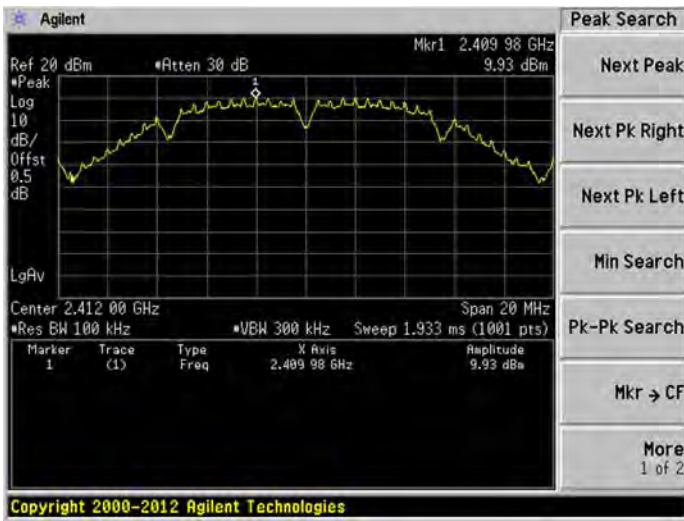
ANT 1
802.11b LOW CHANNEL, Carrier level

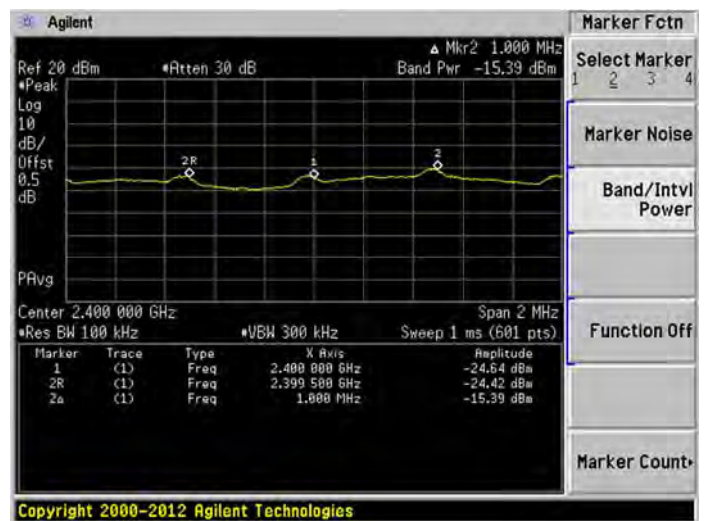
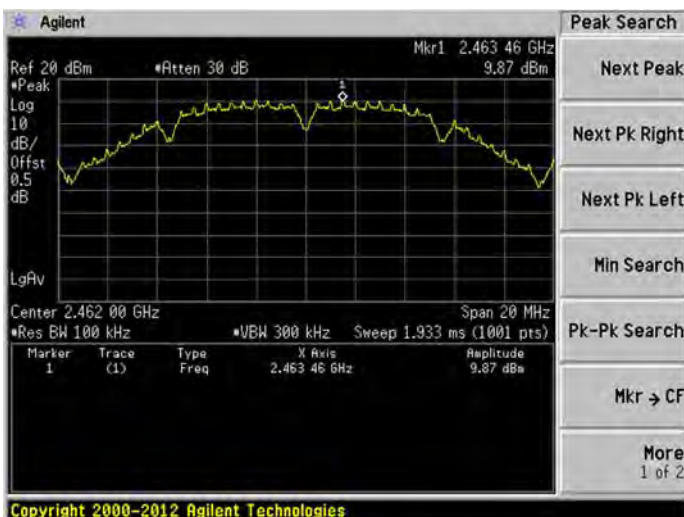
802.11b LOW CHANNEL, Reference level

802.11b LOW CHANNEL, Band Edge

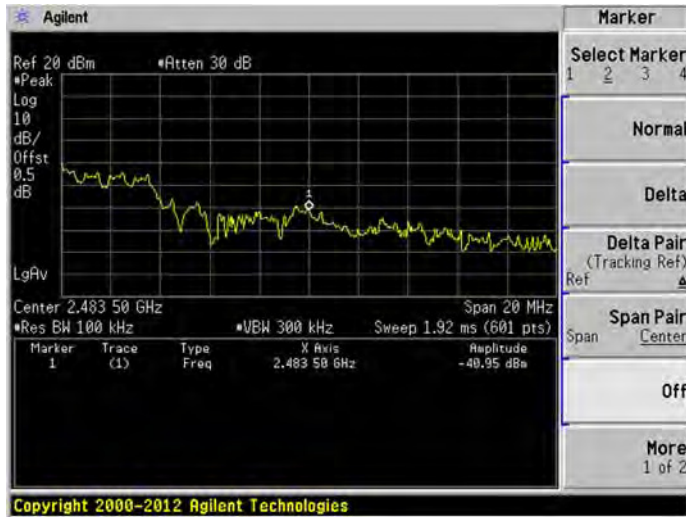
802.11b HIGH CHANNEL, Carrier level

802.11b HIGH CHANNEL, Reference level

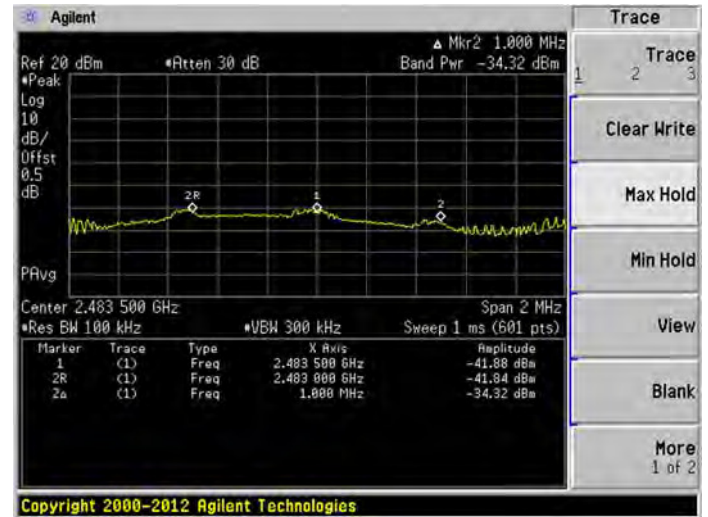

802.11b HIGH CHANNEL, Band Edge



802.11g LOW CHANNEL, Carrier level

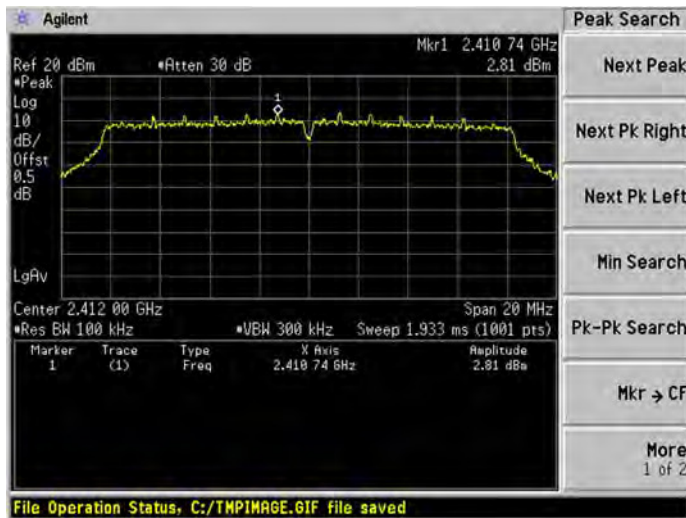

802.11g LOW CHANNEL, Band Edge

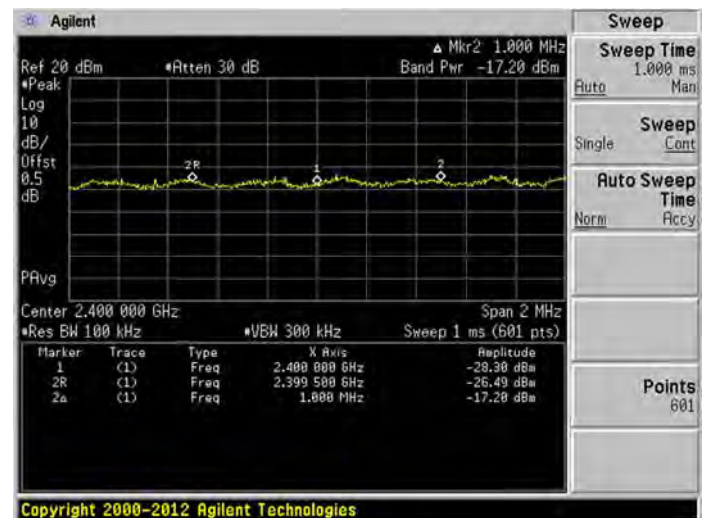

802.11g HIGH CHANNEL, Carrier level

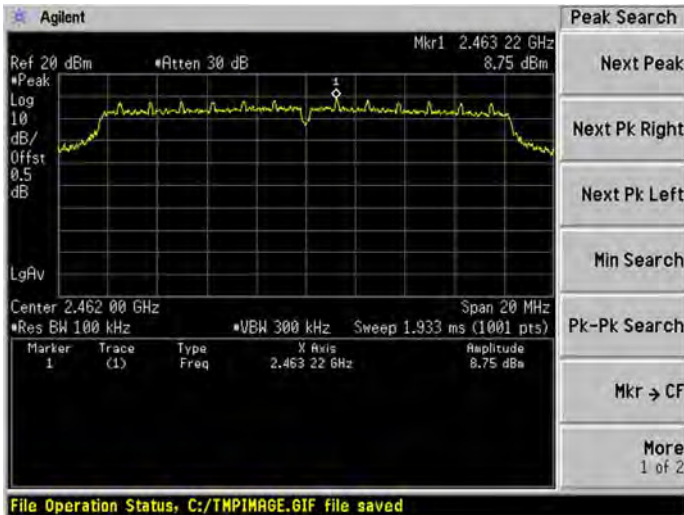

802.11g HIGH CHANNEL, Reference level

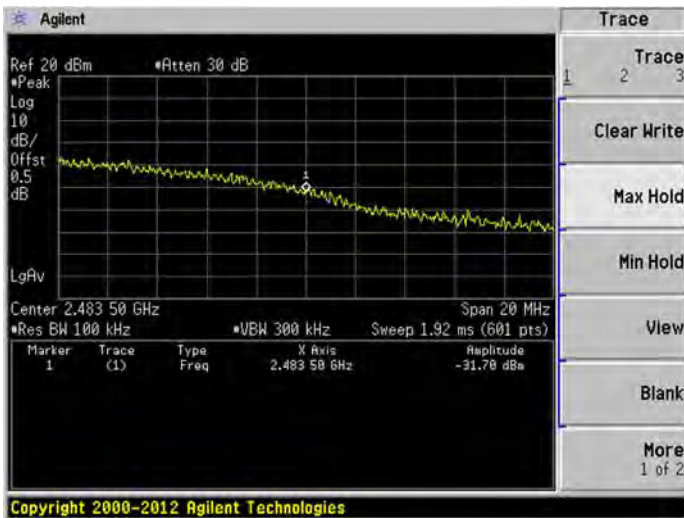

802.11g HIGH CHANNEL, Band Edge

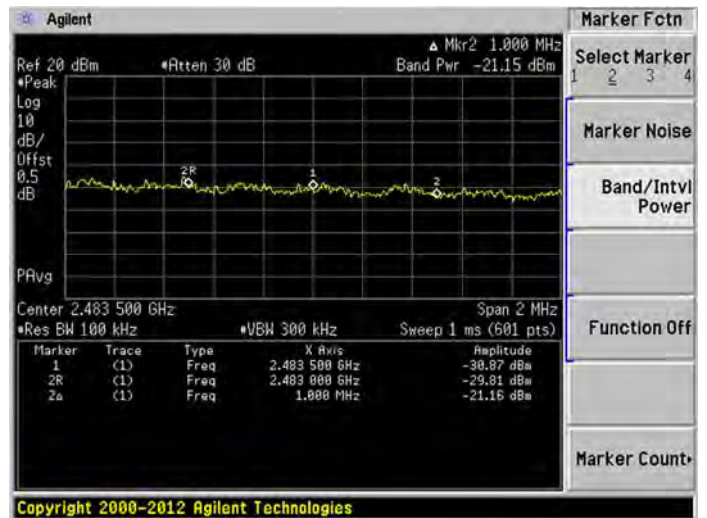

802.11n-20 MHz LOW CHANNEL, Carrier level

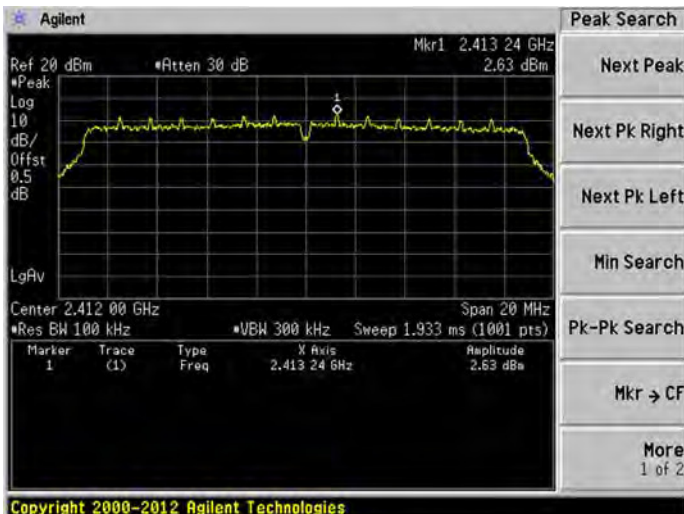

802.11n-20 MHz LOW CHANNEL, Reference level

802.11n-20 MHz LOW CHANNEL, Band Edge

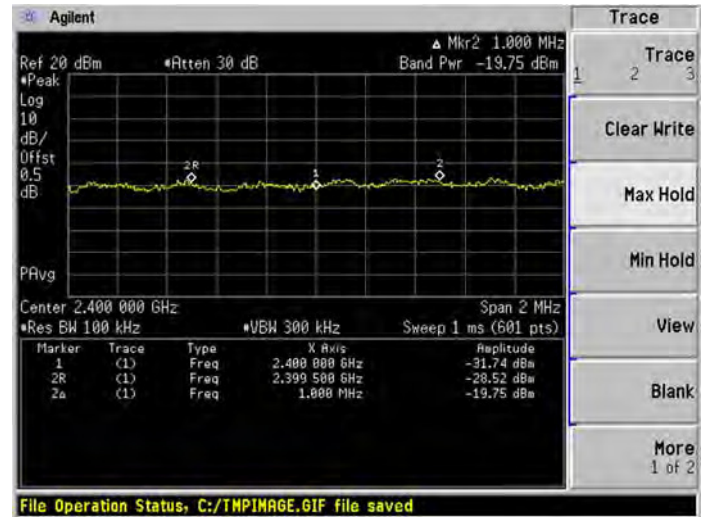
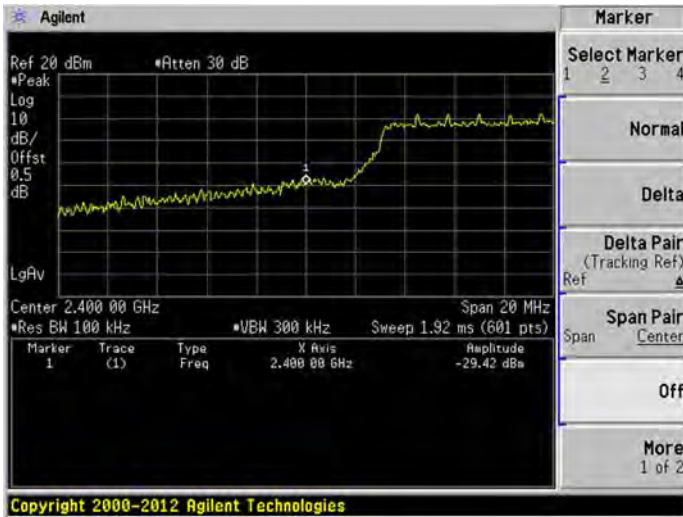

802.11n-20 MHz HIGH CHANNEL, Carrier level

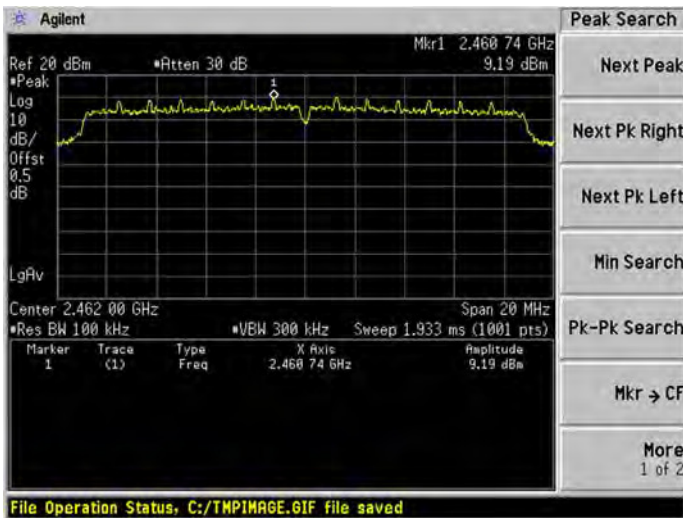

802.11n-20 MHz HIGH CHANNEL, Reference level

802.11n-20 MHz HIGH CHANNEL, Band Edge

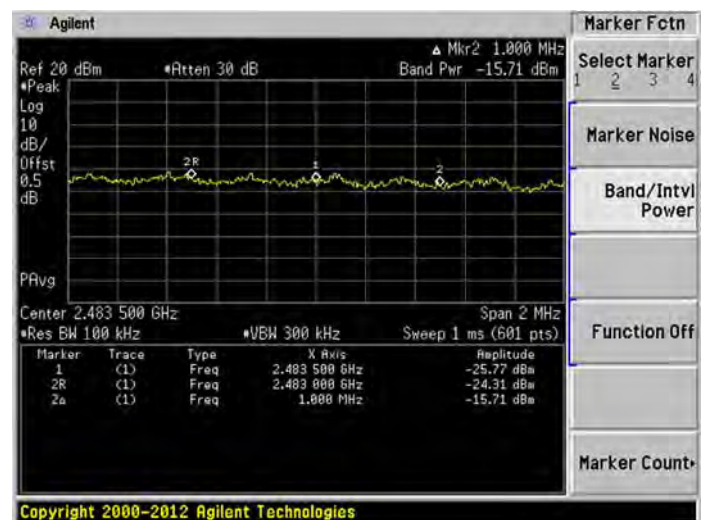
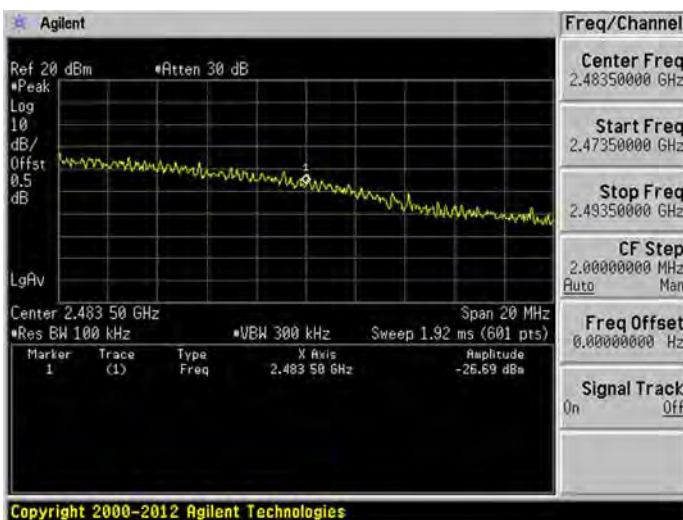

802.11n-40 MHz LOW CHANNEL, Carrier level

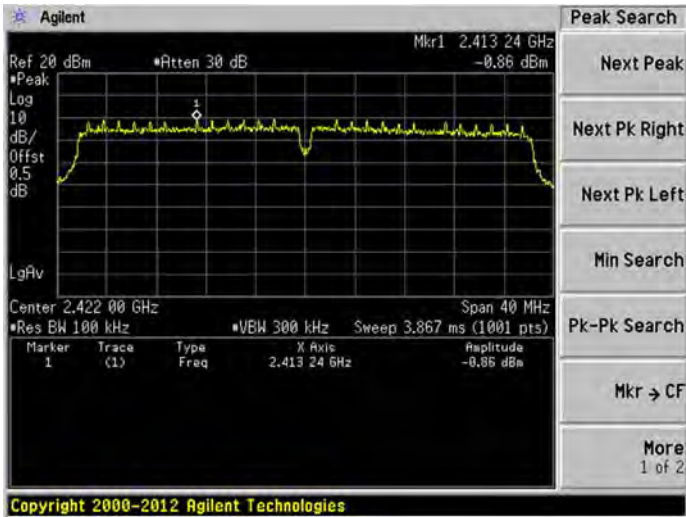

802.11n-40 MHz LOW CHANNEL, Reference level

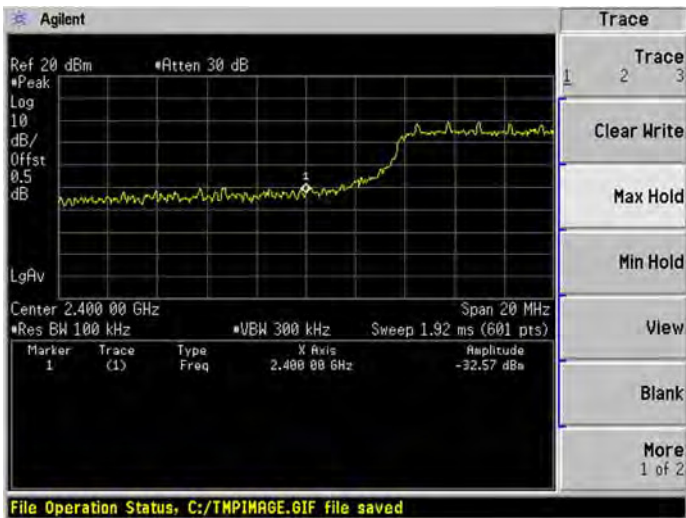

802.11n-40 MHz LOW CHANNEL, Band Edge

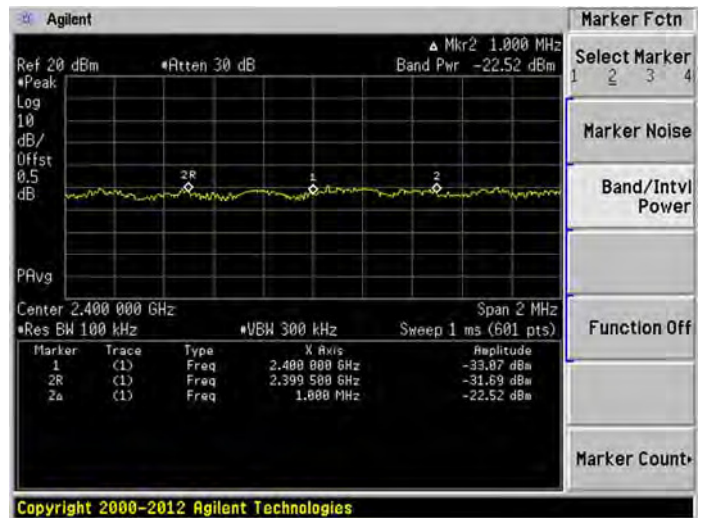

802.11n-40 MHz HIGH CHANNEL, Carrier level

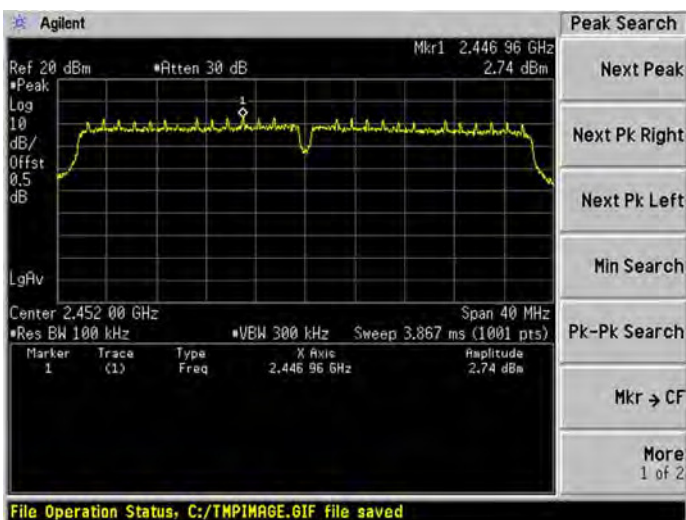

802.11n-40 MHz HIGH CHANNEL, Reference level

802.11n-40 MHz HIGH CHANNEL, Band Edge

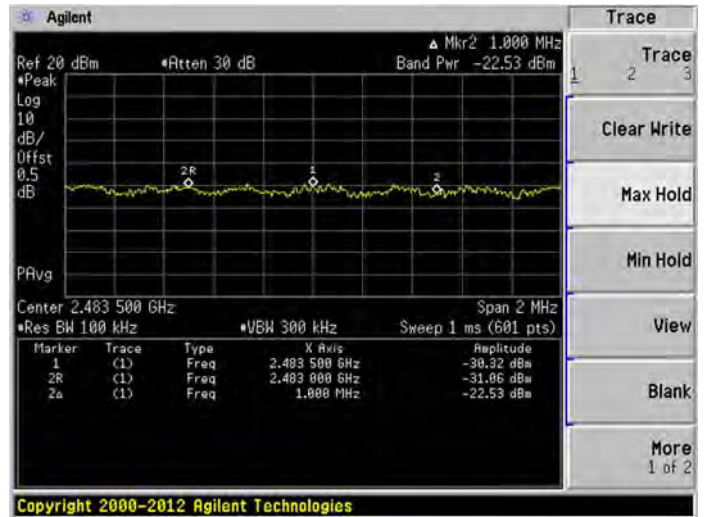
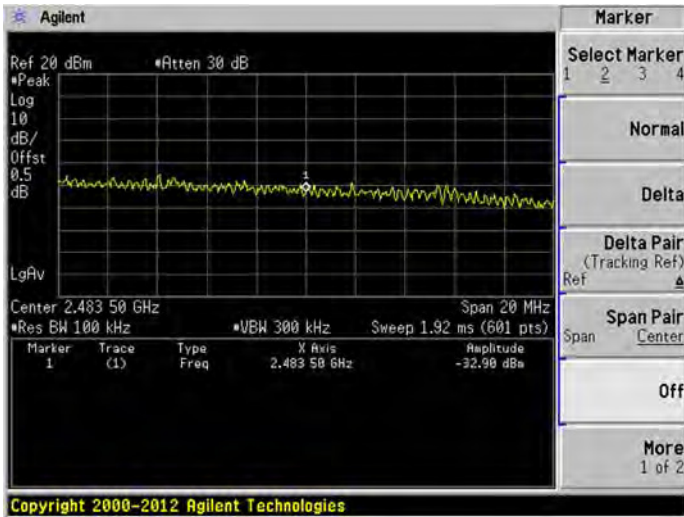

A.5 Conducted Emissions

Note: All configurations have been tested, only the worst configuration (802.11b High Channel) shown here.

Test Data and Plots

PHASE L

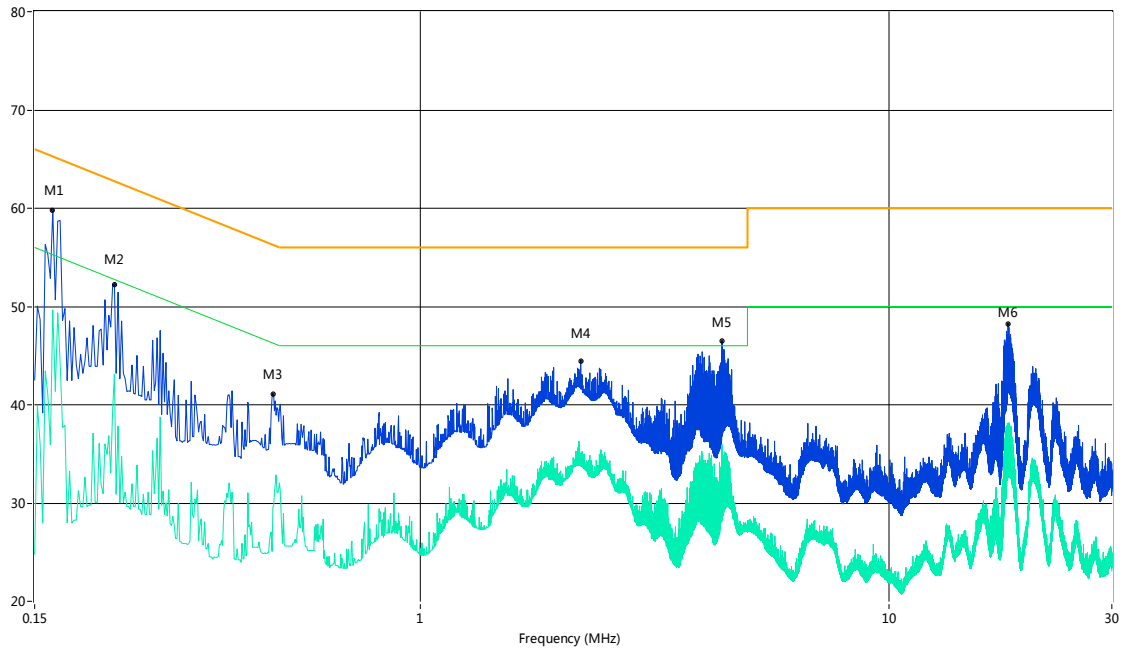

| No. | Frequency (MHz) | Results (dBuV) | Factor (dB) | Limit (dBuV) | Margin (dB) | Detector | Line | Verdict |
|-----|-----------------|----------------|-------------|--------------|-------------|----------|--------|---------|
| 1 | 0.16 | 59.8 | 13.00 | 65.6 | 5.80 | Peak | L Line | Pass |
| 1** | 0.16 | 49.6 | 13.00 | 55.6 | 6.00 | AV | L Line | Pass |
| 2 | 0.22 | 52.3 | 13.00 | 63.9 | 11.60 | Peak | L Line | Pass |
| 2** | 0.22 | 43.1 | 13.00 | 53.9 | 10.80 | AV | L Line | Pass |
| 3 | 0.48 | 41.1 | 13.00 | 56.5 | 15.40 | Peak | L Line | Pass |
| 3** | 0.48 | 29.6 | 13.00 | 46.5 | 16.90 | AV | L Line | Pass |
| 4 | 2.20 | 44.5 | 13.00 | 56.0 | 11.50 | Peak | L Line | Pass |
| 4** | 2.20 | 34.8 | 13.00 | 46.0 | 11.20 | AV | L Line | Pass |
| 5 | 4.41 | 46.4 | 13.00 | 56.0 | 9.60 | Peak | L Line | Pass |
| 5** | 4.41 | 35.9 | 13.00 | 46.0 | 10.10 | AV | L Line | Pass |
| 6 | 18.01 | 48.2 | 13.00 | 60.0 | 11.80 | Peak | L Line | Pass |
| 6** | 18.01 | 36.9 | 13.00 | 50.0 | 13.10 | AV | L Line | Pass |

PHASE N

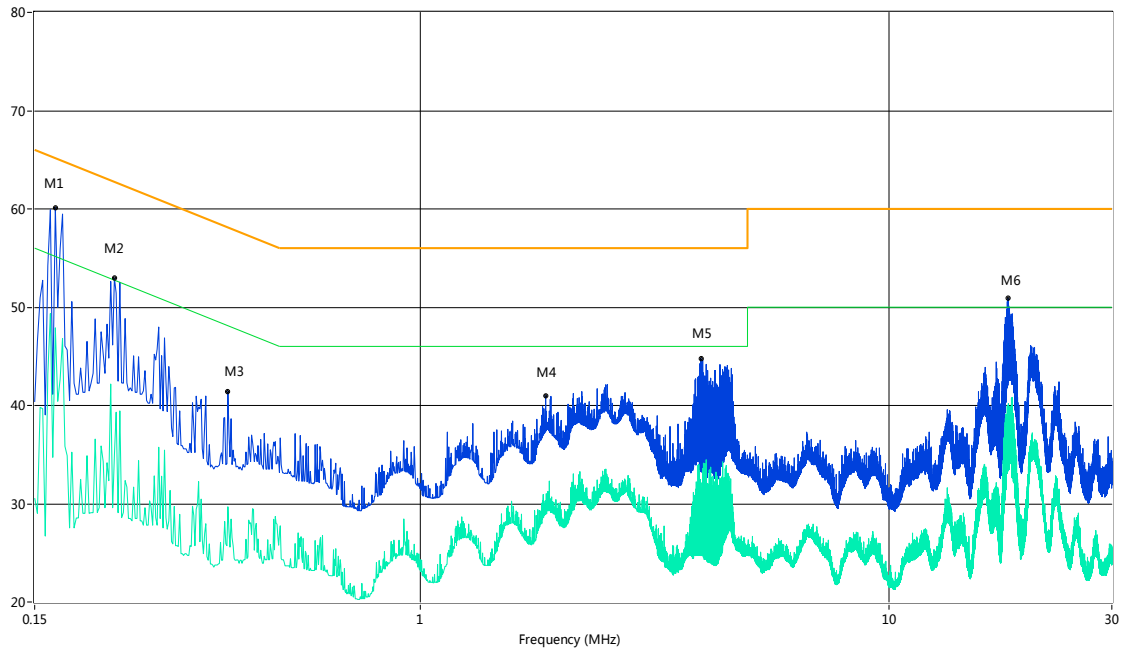

| No. | Frequency (MHz) | Results (dBuV) | Factor (dB) | Limit (dBuV) | Margin (dB) | Detector | Line | Verdict |
|-----|-----------------|----------------|-------------|--------------|-------------|----------|--------|---------|
| 1 | 0.17 | 60.2 | 13.00 | 65.5 | 5.30 | Peak | N Line | Pass |
| 1** | 0.17 | 47.9 | 13.00 | 55.5 | 7.60 | AV | N Line | Pass |
| 2 | 0.22 | 53.0 | 13.00 | 63.9 | 10.90 | Peak | N Line | Pass |
| 2** | 0.22 | 34.9 | 13.00 | 53.9 | 19.00 | AV | N Line | Pass |
| 3 | 0.39 | 41.4 | 13.00 | 59.2 | 17.80 | Peak | N Line | Pass |
| 3** | 0.39 | 29.7 | 13.00 | 49.2 | 19.50 | AV | N Line | Pass |
| 4 | 1.85 | 41.0 | 13.00 | 56.0 | 15.00 | Peak | N Line | Pass |
| 4** | 1.85 | 30.3 | 13.00 | 46.0 | 15.70 | AV | N Line | Pass |
| 5 | 3.98 | 44.8 | 13.00 | 56.0 | 11.20 | Peak | N Line | Pass |
| 5** | 3.98 | 30.4 | 13.00 | 46.0 | 15.60 | AV | N Line | Pass |
| 6 | 18.02 | 50.9 | 13.00 | 60.0 | 9.10 | Peak | N Line | Pass |
| 6** | 18.02 | 38.9 | 13.00 | 50.0 | 11.10 | AV | N Line | Pass |

A.6 Radiated Emission

Radiated spurious emission test

Note 1: The symbol of "--" in the table which means not application.

Note 2: For the test data above 1 GHz, according the ANSI C63.4-2014, where limits are specified for both average and peak (or quasi-peak) detector functions, if the peak (or quasi-peak) measured value complies with the average limit, it is unnecessary to perform an average measurement.

Note 3: The low frequency, which started from 9 kHz to 30 MHz, was pre-scanned and the result which was 20 dB lower than the limit line per 15.31(o) was not reported.

Note 4: All configurations have been tested, only the worst configuration (802.11b High Channel) shown here.

30 MHz to 1 GHz, ANT H 802.11b Low Channel

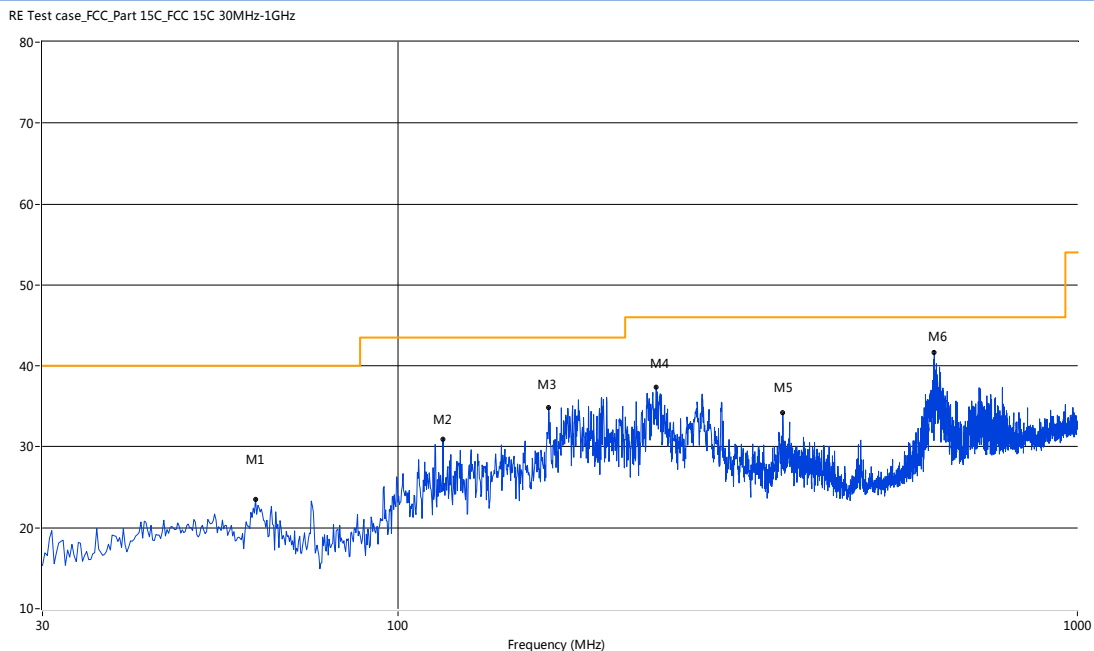

| No. | Frequency (MHz) | Results (dBuV/m) | Factor (dB) | Limit (dBuV/m) | Margin (dB) | Detector | Table (o) | Height (cm) | ANT | Verdict |
|-----|-----------------|------------------|-------------|----------------|-------------|----------|-----------|-------------|------------|---------|
| 1 | 61.76 | 23.51 | -20.29 | 40.0 | 16.49 | Peak | 342.00 | 100 | Horizontal | N/A |
| 1* | 61.76 | 3.83 | -20.29 | 40.0 | 36.17 | QP | 342.00 | 100 | Horizontal | Pass |
| 2 | 116.55 | 30.94 | -21.21 | 43.5 | 12.56 | Peak | 4.00 | 100 | Horizontal | N/A |
| 2* | 116.55 | 10.43 | -21.21 | 43.5 | 33.07 | QP | 4.00 | 100 | Horizontal | Pass |
| 3 | 166.74 | 34.85 | -22.85 | 43.5 | 8.65 | Peak | 172.00 | 100 | Horizontal | N/A |
| 3* | 166.74 | 13.75 | -22.85 | 43.5 | 29.75 | QP | 172.00 | 100 | Horizontal | Pass |
| 4 | 239.95 | 37.35 | -19.10 | 46.0 | 8.65 | Peak | 254.00 | 100 | Horizontal | N/A |
| 4* | 239.95 | 16.75 | -19.1 | 46.0 | 29.25 | QP | 254.00 | 100 | Horizontal | Pass |
| 5 | 368.45 | 34.22 | -16.00 | 46.0 | 11.78 | Peak | 122.00 | 100 | Horizontal | N/A |
| 5* | 368.45 | 16.41 | -16 | 46.0 | 29.59 | QP | 122.00 | 100 | Horizontal | Pass |
| 6 | 615.73 | 41.68 | -10.36 | 46.0 | 4.32 | Peak | 182.00 | 100 | Horizontal | N/A |
| 6* | 615.73 | 23.34 | -10.36 | 46.0 | 22.66 | QP | 182.00 | 100 | Horizontal | Pass |

30 MHz to 1 GHz, ANT V 802.11b Low Channel

RE Test case_FCC_Part 15C_FCC 15C 30MHz-1GHz

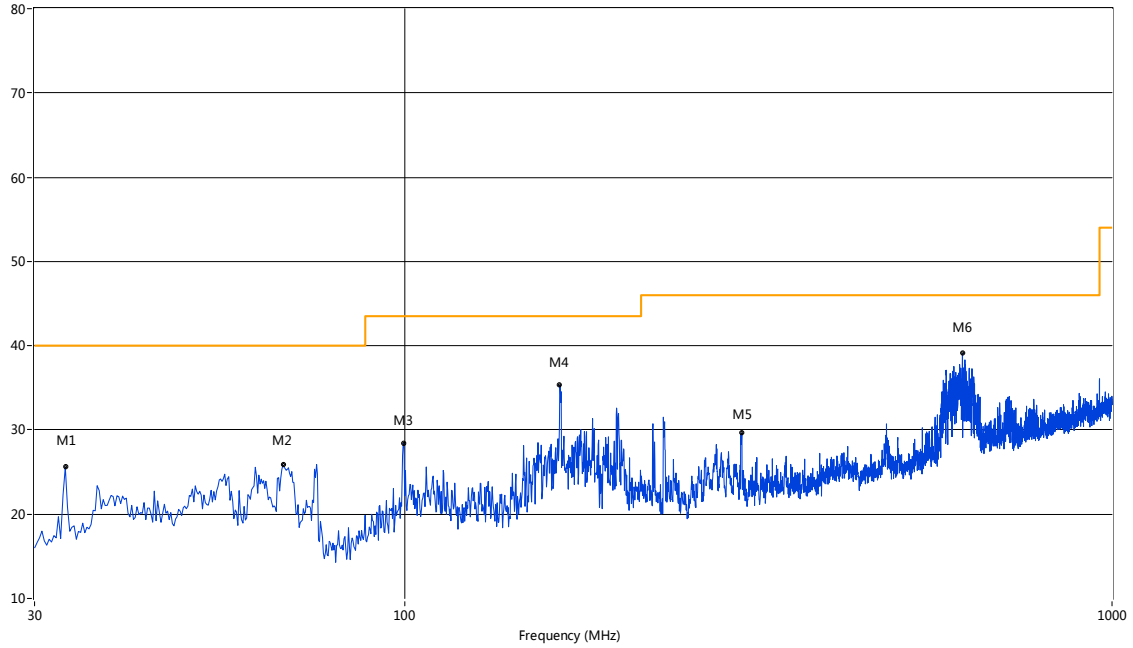

| No. | Frequency (MHz) | Results (dBuV/m) | Factor (dB) | Limit (dBuV/m) | Margin (dB) | Detector | Table (o) | Height (cm) | ANT | Verdict |
|-----|-----------------|------------------|-------------|----------------|-------------|----------|-----------|-------------|----------|---------|
| 1 | 33.15 | 25.59 | -21.90 | 40.0 | 14.41 | Peak | 242.00 | 100 | Vertical | N/A |
| 1* | 33.15 | 5.47 | -21.9 | 40.0 | 34.53 | QP | 242.00 | 100 | Vertical | Pass |
| 2 | 67.34 | 25.85 | -21.61 | 40.0 | 14.15 | Peak | 18.00 | 100 | Vertical | N/A |
| 2* | 67.34 | 6.34 | -21.61 | 40.0 | 33.66 | QP | 18.00 | 100 | Vertical | Pass |
| 3 | 99.82 | 28.45 | -20.20 | 43.5 | 15.05 | Peak | 118.00 | 100 | Vertical | N/A |
| 3* | 99.82 | 14.75 | -20.2 | 43.5 | 28.75 | QP | 118.00 | 100 | Vertical | Pass |
| 4 | 165.77 | 35.34 | -22.91 | 43.5 | 8.16 | Peak | 267.00 | 100 | Vertical | N/A |
| 4* | 165.77 | 17.37 | -22.91 | 43.5 | 26.13 | QP | 267.00 | 100 | Vertical | Pass |
| 5 | 299.59 | 29.66 | -17.64 | 46.0 | 16.34 | Peak | 47.00 | 100 | Vertical | N/A |
| 5* | 299.59 | 12.38 | -17.64 | 46.0 | 33.62 | QP | 47.00 | 100 | Vertical | Pass |
| 6 | 614.52 | 39.08 | -10.24 | 46.0 | 6.92 | Peak | 298.00 | 100 | Vertical | N/A |
| 6* | 614.52 | 20.76 | -10.24 | 46 | 25.24 | QP | 298.00 | 100 | Vertical | Pass |

1 GHz to 25 GHz, ANT V 802.11b Low Channel

| No. | Frequency (MHz) | Results (dBuV/m) | Factor (dB) | Limit (dBuV/m) | Margin (dB) | Detector | Table (o) | Height (cm) | ANT | Verdict |
|-----|-----------------|------------------|-------------|----------------|-------------|----------|-----------|-------------|----------|---------|
| 1 | 1192.45 | 45.81 | -5.42 | 74.0 | 28.19 | Peak | 122.30 | 100 | Vertical | Pass |
| 2 | 1442.39 | 46.92 | -4.52 | 74.0 | 27.08 | Peak | 280.40 | 100 | Vertical | Pass |
| 3 | 1796.80 | 52.95 | -3.70 | 74.0 | 21.05 | Peak | 173.40 | 100 | Vertical | Pass |
| 4 | 2410.15 | 99.53 | -0.12 | 74.0 | -25.53 | Peak | 179.80 | 100 | Vertical | N/A |
| 5 | 3215.95 | 47.99 | 9.18 | 74.0 | 26.01 | Peak | 117.70 | 100 | Vertical | Pass |
| 6** | 4823.99 | 50.86 | 13.77 | 54.0 | 3.14 | AV | 196.60 | 141.90 | Vertical | Pass |
| 6 | 4823.99 | 56.83 | 13.77 | 74.0 | 17.17 | Peak | 196.60 | 141.90 | Vertical | Pass |
| 7 | 12008.74 | 52.04 | 20.87 | 74.0 | 21.96 | Peak | 311.20 | 100 | Vertical | Pass |
| 8 | 19149.75 | 50.64 | 13.93 | 74.0 | 23.36 | Peak | 356.30 | 100 | Vertical | Pass |

1 GHz to 25 GHz, ANT H 802.11b Low Channel

| No. | Frequency (MHz) | Results (dBuV/m) | Factor (dB) | Limit (dBuV/m) | Margin (dB) | Detector | Table (o) | Height (cm) | ANT | Verdict |
|-----|-----------------|------------------|-------------|----------------|-------------|----------|-----------|-------------|------------|---------|
| 1 | 1442.39 | 46.14 | -4.23 | 74.0 | 27.86 | Peak | 196.00 | 100 | Horizontal | Pass |
| 2 | 1764.81 | 48.37 | -3.30 | 74.0 | 25.63 | Peak | 239.00 | 100 | Horizontal | Pass |
| 3 | 2410.15 | 114.31 | 0.17 | 74.0 | -40.31 | Peak | 277.00 | 100 | Horizontal | N/A |
| 4 | 2753.06 | 51.01 | 2.20 | 74.0 | 22.99 | Peak | 242.00 | 100 | Horizontal | Pass |
| 5 | 3215.95 | 52.76 | 9.18 | 74.0 | 21.24 | Peak | 222.00 | 100 | Horizontal | Pass |
| 6 | 4824.29 | 57.66 | 13.77 | 74.0 | 16.34 | Peak | 341.00 | 100 | Horizontal | Pass |
| 6** | 4824.29 | 52.42 | 13.77 | 54.0 | 1.58 | AV | 341.00 | 100 | Horizontal | Pass |
| 7 | 12323.21 | 52.06 | 20.64 | 74.0 | 21.94 | Peak | 342.80 | 100 | Horizontal | Pass |
| 8 | 19309.48 | 51.70 | 13.46 | 74.0 | 22.30 | Peak | 57.90 | 100 | Horizontal | Pass |

1 GHz to 25 GHz, ANT V 802.11b Middle Channel

| No. | Frequency (MHz) | Results (dBuV/m) | Factor (dB) | Limit (dBuV/m) | Margin (dB) | Detector | Table (o) | Height (cm) | ANT | Verdict |
|-----|-----------------|------------------|-------------|----------------|-------------|----------|-----------|-------------|----------|---------|
| 1 | 1055.49 | 45.40 | -6.18 | 74.0 | 28.60 | Peak | 263.00 | 100 | Vertical | Pass |
| 2 | 1439.89 | 52.00 | -4.59 | 74.0 | 22.00 | Peak | 286.40 | 100 | Vertical | Pass |
| 3 | 1797.30 | 53.14 | -3.69 | 74.0 | 20.86 | Peak | 44.00 | 100 | Vertical | Pass |
| 4 | 2435.14 | 98.65 | -0.51 | 74.0 | -24.65 | Peak | 110.00 | 100 | Vertical | N/A |
| 5 | 3248.94 | 47.70 | 9.07 | 74.0 | 26.30 | Peak | 261.60 | 100 | Vertical | Pass |
| 6** | 4873.78 | 50.51 | 13.66 | 54.0 | 3.49 | AV | 195.46. | 100 | Vertical | Pass |
| 6 | 4873.78 | 54.97 | 13.66 | 74.0 | 19.03 | Peak | 195.46. | 100 | Vertical | Pass |
| 7 | 12233.36 | 51.68 | 20.65 | 74.0 | 22.32 | Peak | 0.90 | 100 | Vertical | Pass |
| 8 | 18022.46 | 50.26 | 13.26 | 74.0 | 23.74 | Peak | 167.10 | 100 | Vertical | Pass |

1 GHz to 25 GHz, ANT H 802.11b Middle Channel

| No. | Frequency (MHz) | Results (dBuV/m) | Factor (dB) | Limit (dBuV/m) | Margin (dB) | Detector | Table (o) | Height (cm) | ANT | Verdict |
|-----|-----------------|------------------|-------------|----------------|-------------|----------|-----------|-------------|------------|---------|
| 1 | 1440.39 | 47.03 | -4.16 | 74.0 | 26.97 | Peak | 180.00 | 100 | Horizontal | Pass |
| 2 | 1687.33 | 48.70 | -3.70 | 74.0 | 25.30 | Peak | 215.00 | 100 | Horizontal | Pass |
| 3 | 2439.64 | 117.72 | 0.23 | 74.0 | -43.72 | Peak | 197.00 | 100 | Horizontal | N/A |
| 4 | 2729.07 | 51.23 | 2.47 | 74.0 | 22.77 | Peak | 50.00 | 100 | Horizontal | Pass |
| 5 | 3249.69 | 52.01 | 9.09 | 74.0 | 21.99 | Peak | 163.00 | 100 | Horizontal | Pass |
| 6 | 4708.82 | 51.98 | 13.38 | 74.0 | 22.02 | Peak | 5.00 | 100 | Horizontal | Pass |
| 7 | 12008.74 | 52.04 | 20.87 | 74.0 | 21.96 | Peak | 311.20 | 100 | Horizontal | Pass |
| 8 | 19149.75 | 50.64 | 13.93 | 74.0 | 23.36 | Peak | 356.30 | 100 | Horizontal | Pass |

1 GHz to 25 GHz, ANT V 802.11b High Channel

| No. | Frequency (MHz) | Results (dBuV/m) | Factor (dB) | Limit (dBuV/m) | Margin (dB) | Detector | Table (o) | Height (cm) | ANT | Verdict |
|-----|-----------------|------------------|-------------|----------------|-------------|----------|-----------|-------------|----------|---------|
| 1 | 1218.45 | 45.00 | -5.14 | 74.0 | 29.00 | Peak | 131.10 | 100 | Vertical | Pass |
| 2 | 1440.39 | 53.39 | -4.55 | 74.0 | 20.61 | Peak | 270.10 | 100 | Vertical | Pass |
| 3 | 1661.33 | 49.02 | -4.15 | 74.0 | 24.98 | Peak | 131.10 | 100 | Vertical | Pass |
| 4 | 2463.63 | 99.34 | -0.55 | 74.0 | -25.34 | Peak | 213.20 | 100 | Vertical | N/A |
| 5 | 3967.26 | 49.19 | 11.11 | 74.0 | 24.81 | Peak | 358.60 | 100 | Vertical | Pass |
| 6** | 4923.92 | 50.90 | 13.86 | 54.0 | 3.10 | AV | 187.50 | 100 | Vertical | Pass |
| 6 | 4923.92 | 56.08 | 13.86 | 74.0 | 17.92 | Peak | 187.50 | 100 | Vertical | Pass |
| 7 | 12323.21 | 52.06 | 20.64 | 74.0 | 21.94 | Peak | 342.80 | 100 | Vertical | Pass |
| 8 | 19309.48 | 51.70 | 13.46 | 74.0 | 22.30 | Peak | 57.90 | 100 | Vertical | Pass |

1 GHz to 25 GHz, ANT H 802.11b High Channel

| No. | Frequency (MHz) | Results (dBuV/m) | Factor (dB) | Limit (dBuV/m) | Margin (dB) | Detector | Table (o) | Height (cm) | ANT | Verdict |
|-----|-----------------|------------------|-------------|----------------|-------------|----------|-----------|-------------|------------|---------|
| 1 | 1441.39 | 48.61 | -4.09 | 74.0 | 25.39 | Peak | 205.00 | 100 | Horizontal | Pass |
| 2 | 1679.83 | 50.82 | -3.51 | 74.0 | 23.18 | Peak | 34.00 | 100 | Horizontal | Pass |
| 3 | 2463.13 | 118.45 | -0.13 | 74.0 | -44.45 | Peak | 96.00 | 100 | Horizontal | N/A |
| 4 | 2780.05 | 51.42 | 2.39 | 74.0 | 22.58 | Peak | 290.00 | 100 | Horizontal | Pass |
| 5 | 3282.68 | 50.77 | 8.89 | 74.0 | 23.23 | Peak | 138.00 | 100 | Horizontal | Pass |
| 6** | 4924.02 | 51.56 | 13.86 | 54.0 | 2.44 | AV | 306.00 | 100 | Horizontal | Pass |
| 6 | 4924.02 | 56.75 | 13.86 | 74.0 | 17.25 | Peak | 306.00 | 100 | Horizontal | Pass |
| 7 | 11649.33 | 51.92 | 20.41 | 74.0 | 22.08 | Peak | 0.60 | 100 | Horizontal | Pass |
| 8 | 19309.48 | 51.70 | 13.46 | 74.0 | 22.30 | Peak | 57.90 | 100 | Horizontal | Pass |

1 GHz to 25 GHz, ANT V 802.11g Low Channel

| No. | Frequency (MHz) | Results (dBuV/m) | Factor (dB) | Limit (dBuV/m) | Margin (dB) | Detector | Table (o) | Height (cm) | ANT | Verdict |
|-----|-----------------|------------------|-------------|----------------|-------------|----------|-----------|-------------|----------|---------|
| 1 | 1439.89 | 52.41 | -4.59 | 74.0 | 21.59 | Peak | 285.90 | 100 | Vertical | Pass |
| 2 | 1681.83 | 49.98 | -4.16 | 74.0 | 24.02 | Peak | 177.00 | 100 | Vertical | Pass |
| 3 | 1797.30 | 51.02 | -3.69 | 74.0 | 22.98 | Peak | 157.40 | 100 | Vertical | Pass |
| 4 | 2408.65 | 98.57 | -0.09 | 74.0 | -24.57 | Peak | 306.10 | 100 | Vertical | N/A |
| 5 | 3873.53 | 49.19 | 10.85 | 74.0 | 24.81 | Peak | 113.70 | 100 | Vertical | Pass |
| 6 | 5150.46 | 51.86 | 15.09 | 74.0 | 22.14 | Peak | 81.60 | 100 | Vertical | Pass |
| 7 | 11649.33 | 51.92 | 20.41 | 74.0 | 22.08 | Peak | 0.60 | 100 | Vertical | Pass |
| 8 | 19169.72 | 50.77 | 14.01 | 74.0 | 23.23 | Peak | 335.90 | 100 | Vertical | Pass |

1 GHz to 25 GHz, ANT H 802.11g Low Channel

| No. | Frequency (MHz) | Results (dBuV/m) | Factor (dB) | Limit (dBuV/m) | Margin (dB) | Detector | Table (o) | Height (cm) | ANT | Verdict |
|-----|-----------------|------------------|-------------|----------------|-------------|----------|-----------|-------------|------------|---------|
| 1 | 1438.89 | 47.36 | -4.22 | 74.0 | 26.64 | Peak | 132.20 | 100 | Horizontal | Pass |
| 2 | 1676.33 | 49.70 | -3.50 | 74.0 | 24.30 | Peak | 288.10 | 100 | Horizontal | Pass |
| 3 | 2411.15 | 114.31 | 0.27 | 74.0 | -40.31 | Peak | 188.70 | 100 | Horizontal | N/A |
| 4 | 3215.95 | 52.14 | 9.18 | 74.0 | 21.86 | Peak | 359.50 | 100 | Horizontal | Pass |
| 5 | 4459.89 | 52.09 | 12.46 | 74.0 | 21.91 | Peak | 5.10 | 100 | Horizontal | Pass |
| 6 | 5658.84 | 51.28 | 15.52 | 74.0 | 22.72 | Peak | 331.10 | 100 | Horizontal | Pass |
| 7 | 11649.33 | 52.05 | 20.41 | 74.0 | 21.95 | Peak | 0.30 | 100 | Horizontal | Pass |
| 8 | 19309.48 | 51.37 | 13.46 | 74.0 | 22.63 | Peak | 56.70 | 100 | Horizontal | Pass |

1 GHz to 25 GHz, ANT V 802.11g Middle Channel

| No. | Frequency (MHz) | Results (dBuV/m) | Factor (dB) | Limit (dBuV/m) | Margin (dB) | Detector | Table (o) | Height (cm) | ANT | Verdict |
|-----|-----------------|------------------|-------------|----------------|-------------|----------|-----------|-------------|----------|---------|
| 1 | 1440.39 | 52.21 | -4.55 | 74.0 | 21.79 | Peak | 253.70 | 100 | Vertical | Pass |
| 2 | 1678.33 | 47.95 | -4.23 | 74.0 | 26.05 | Peak | 139.20 | 100 | Vertical | Pass |
| 3 | 1792.30 | 47.56 | -3.68 | 74.0 | 26.44 | Peak | 114.00 | 100 | Vertical | Pass |
| 4 | 2436.14 | 105.62 | -0.46 | 74.0 | -31.62 | Peak | 132.90 | 100 | Vertical | N/A |
| 5 | 3422.89 | 46.86 | 9.28 | 74.0 | 27.14 | Peak | -0.70 | 100 | Vertical | Pass |
| 6 | 4873.03 | 52.44 | 13.65 | 74.0 | 21.56 | Peak | 127.80 | 100 | Vertical | Pass |
| 7 | 11278.70 | 51.10 | 20.21 | 74.0 | 22.90 | Peak | 49.00 | 100 | Vertical | Pass |
| 8 | 19169.72 | 50.74 | 14.01 | 74.0 | 23.26 | Peak | 335.70 | 100 | Vertical | Pass |

1 GHz to 25 GHz, ANT H 802.11g Middle Channel

| No. | Frequency (MHz) | Results (dBuV/m) | Factor (dB) | Limit (dBuV/m) | Margin (dB) | Detector | Table (o) | Height (cm) | ANT | Verdict |
|-----|-----------------|------------------|-------------|----------------|-------------|----------|-----------|-------------|------------|---------|
| 1 | 1199.45 | 45.54 | -5.30 | 74.0 | 28.46 | Peak | 80.80 | 100 | Horizontal | Pass |
| 2 | 1440.39 | 47.08 | -4.55 | 74.0 | 26.92 | Peak | 215.30 | 100 | Horizontal | Pass |
| 3 | 1920.27 | 47.53 | -2.46 | 74.0 | 26.47 | Peak | 132.30 | 100 | Horizontal | Pass |
| 4 | 2432.64 | 116.25 | -0.60 | 74.0 | -42.25 | Peak | 80.80 | 100 | Horizontal | N/A |
| 5 | 3249.69 | 49.59 | 9.09 | 74.0 | 24.41 | Peak | 15.70 | 100 | Horizontal | Pass |
| 6** | 4876.43 | 43.67 | 13.67 | 54.0 | 10.33 | AV | 310.60 | 100 | Horizontal | Pass |
| 6 | 4876.43 | 58.58 | 13.67 | 74.0 | 15.42 | Peak | 310.60 | 100 | Horizontal | Pass |
| 7 | 11020.38 | 51.32 | 20.14 | 74.0 | 22.68 | Peak | 168.20 | 100 | Horizontal | Pass |
| 8 | 19309.48 | 51.73 | 13.46 | 74.0 | 22.27 | Peak | 57.70 | 100 | Horizontal | Pass |

1 GHz to 25 GHz, ANT V 802.11g High Channel

| No. | Frequency (MHz) | Results (dBuV/m) | Factor (dB) | Limit (dBuV/m) | Margin (dB) | Detector | Table (o) | Height (cm) | ANT | Verdict |
|-----|-----------------|------------------|-------------|----------------|-------------|----------|-----------|-------------|----------|---------|
| 1 | 1439.89 | 52.07 | -4.59 | 74.0 | 21.93 | Peak | 358.00 | 100 | Vertical | Pass |
| 2 | 1764.81 | 48.41 | -3.76 | 74.0 | 25.59 | Peak | 161.10 | 100 | Vertical | Pass |
| 3 | 2188.20 | 49.03 | -0.78 | 74.0 | 24.97 | Peak | 273.50 | 100 | Vertical | Pass |
| 4 | 2460.13 | 106.03 | -0.61 | 74.0 | -32.03 | Peak | 129.20 | 100 | Vertical | N/A |
| 5 | 3761.06 | 47.88 | 10.46 | 74.0 | 26.12 | Peak | 351.20 | 100 | Vertical | Pass |
| 6** | 4927.57 | 40.51 | 13.96 | 54.0 | 13.49 | AV | 56.50 | 100 | Vertical | Pass |
| 6 | 4927.57 | 56.22 | 13.96 | 74.0 | 17.78 | Peak | 56.50 | 100 | Vertical | Pass |
| 7 | 11739.18 | 51.57 | 20.47 | 74.0 | 22.43 | Peak | 96.20 | 100 | Vertical | Pass |
| 8 | 19309.48 | 51.73 | 13.46 | 74.0 | 22.27 | Peak | 57.70 | 100 | Vertical | Pass |

1 GHz to 25 GHz, ANT H 802.11g High Channel

| No. | Frequency (MHz) | Results (dBuV/m) | Factor (dB) | Limit (dBuV/m) | Margin (dB) | Detector | Table (o) | Height (cm) | ANT | Verdict |
|-----|-----------------|------------------|-------------|----------------|-------------|----------|-----------|-------------|------------|---------|
| 1 | 1440.39 | 50.36 | -4.55 | 74.0 | 23.64 | Peak | 157.40 | 100 | Horizontal | Pass |
| 2 | 1681.33 | 47.95 | -4.16 | 74.0 | 26.05 | Peak | 246.90 | 100 | Horizontal | Pass |
| 3 | 2057.24 | 47.46 | -1.95 | 74.0 | 26.54 | Peak | 170.30 | 100 | Horizontal | Pass |
| 4 | 2463.13 | 116.53 | -0.56 | 74.0 | -42.53 | Peak | 99.30 | 100 | Horizontal | N/A |
| 5 | 3282.68 | 49.65 | 8.89 | 74.0 | 24.35 | Peak | 28.60 | 100 | Horizontal | Pass |
| 6** | 4926.27 | 45.07 | 13.96 | 54.0 | 8.93 | AV | 298.50 | 100 | Horizontal | Pass |
| 6 | 4926.27 | 60.64 | 13.96 | 74.0 | 13.36 | Peak | 298.50 | 100 | Horizontal | Pass |
| 7 | 11649.33 | 51.56 | 20.41 | 74.0 | 22.44 | Peak | -0.10 | 100 | Horizontal | Pass |
| 8 | 19309.48 | 51.73 | 13.46 | 74.0 | 22.27 | Peak | 57.70 | 100 | Horizontal | Pass |

1 GHz to 25 GHz, ANT V 802.11n20 Low Channel

| No. | Frequency (MHz) | Results (dBuV/m) | Factor (dB) | Limit (dBuV/m) | Margin (dB) | Detector | Table (o) | Height (cm) | ANT | Verdict |
|-----|-----------------|------------------|-------------|----------------|-------------|----------|-----------|-------------|----------|---------|
| 1 | 1439.89 | 50.58 | -4.59 | 74.0 | 23.42 | Peak | 267.40 | 100 | Vertical | Pass |
| 2 | 1791.80 | 49.56 | -3.70 | 74.0 | 24.44 | Peak | 158.80 | 100 | Vertical | Pass |
| 3 | 1919.77 | 50.51 | -2.42 | 74.0 | 23.49 | Peak | 273.70 | 100 | Vertical | Pass |
| 4 | 2415.15 | 101.74 | 0.01 | 74.0 | -27.74 | Peak | 127.00 | 100 | Vertical | N/A |
| 5 | 2885.03 | 50.80 | 2.28 | 74.0 | 23.20 | Peak | 330.40 | 100 | Vertical | Pass |
| 6 | 4692.33 | 51.86 | 13.24 | 74.0 | 22.14 | Peak | 146.70 | 100 | Vertical | Pass |
| 7 | 12323.21 | 51.83 | 20.64 | 74.0 | 22.17 | Peak | 344.10 | 100 | Vertical | Pass |
| 8 | 19309.48 | 51.73 | 13.46 | 74.0 | 22.27 | Peak | 57.70 | 100 | Vertical | Pass |

1 GHz to 25 GHz, ANT H 802.11n20 Low Channel

| No. | Frequency (MHz) | Results (dBuV/m) | Factor (dB) | Limit (dBuV/m) | Margin (dB) | Detector | Table (o) | Height (cm) | ANT | Verdict |
|-----|-----------------|------------------|-------------|----------------|-------------|----------|-----------|-------------|------------|---------|
| 1 | 1439.89 | 47.52 | -4.59 | 74.0 | 26.48 | Peak | 311.90 | 100 | Horizontal | Pass |
| 2 | 1681.33 | 47.77 | -4.16 | 74.0 | 26.23 | Peak | 241.50 | 100 | Horizontal | Pass |
| 3 | 1920.27 | 48.32 | -2.46 | 74.0 | 25.68 | Peak | 128.00 | 100 | Horizontal | Pass |
| 4 | 2414.15 | 112.85 | -0.01 | 74.0 | -38.85 | Peak | 77.10 | 100 | Horizontal | N/A |
| 5 | 3216.70 | 48.50 | 9.18 | 74.0 | 25.50 | Peak | 85.70 | 100 | Horizontal | Pass |
| 6 | 4813.80 | 52.32 | 13.96 | 74.0 | 21.68 | Peak | 234.00 | 100 | Horizontal | Pass |
| 7 | 11649.33 | 51.85 | 20.41 | 74.0 | 22.15 | Peak | 0.10 | 100 | Horizontal | Pass |
| 8 | 19309.48 | 51.73 | 13.46 | 74.0 | 22.27 | Peak | 57.70 | 100 | Horizontal | Pass |

1 GHz to 25 GHz, ANT V 802.11n20 Middle Channel

| No. | Frequency (MHz) | Results (dBuV/m) | Factor (dB) | Limit (dBuV/m) | Margin (dB) | Detector | Table (o) | Height (cm) | ANT | Verdict |
|-----|-----------------|------------------|-------------|----------------|-------------|----------|-----------|-------------|----------|---------|
| 1 | 1439.89 | 51.97 | -4.59 | 74.0 | 22.03 | Peak | 260.60 | 100 | Vertical | Pass |
| 2 | 1693.33 | 49.30 | -4.20 | 74.0 | 24.70 | Peak | 353.80 | 100 | Vertical | Pass |
| 3 | 2127.22 | 47.84 | -0.95 | 74.0 | 26.16 | Peak | 88.50 | 100 | Vertical | Pass |
| 4 | 2434.14 | 102.78 | -0.57 | 74.0 | -28.78 | Peak | 126.60 | 100 | Vertical | N/A |
| 5 | 3633.59 | 48.03 | 10.09 | 74.0 | 25.97 | Peak | 140.90 | 100 | Vertical | Pass |
| 6 | 4863.28 | 52.44 | 13.59 | 74.0 | 21.56 | Peak | 71.20 | 100 | Vertical | Pass |
| 7 | 12008.74 | 51.93 | 20.87 | 74.0 | 22.07 | Peak | 311.00 | 100 | Vertical | Pass |
| 8 | 19309.48 | 51.73 | 13.46 | 74.0 | 22.27 | Peak | 57.70 | 100 | Vertical | Pass |

1 GHz to 25 GHz, ANT H 802.11n20 Middle Channel

| No. | Frequency (MHz) | Results (dBuV/m) | Factor (dB) | Limit (dBuV/m) | Margin (dB) | Detector | Table (o) | Height (cm) | ANT | Verdict |
|-----|-----------------|------------------|-------------|----------------|-------------|----------|-----------|-------------|------------|---------|
| 1 | 1440.39 | 49.72 | -4.55 | 74.0 | 24.28 | Peak | 317.40 | 100 | Horizontal | Pass |
| 2 | 1681.33 | 46.12 | -4.16 | 74.0 | 27.88 | Peak | 176.50 | 100 | Horizontal | Pass |
| 3 | 1920.27 | 48.99 | -2.46 | 74.0 | 25.01 | Peak | 119.40 | 100 | Horizontal | Pass |
| 4 | 2439.64 | 115.28 | -0.46 | 74.0 | -41.28 | Peak | 113.00 | 100 | Horizontal | N/A |
| 5 | 3249.69 | 49.94 | 9.09 | 74.0 | 24.06 | Peak | 24.70 | 100 | Horizontal | Pass |
| 6** | 4878.68 | 45.81 | 13.71 | 54.0 | 8.19 | AV | 29.10 | 100 | Horizontal | Pass |
| 6 | 4878.68 | 57.40 | 13.71 | 74.0 | 16.60 | Peak | 29.10 | 100 | Horizontal | Pass |
| 7 | 12008.74 | 52.20 | 20.87 | 74.0 | 21.80 | Peak | 310.60 | 100 | Horizontal | Pass |
| 8 | 19309.48 | 50.41 | 13.46 | 74.0 | 23.59 | Peak | 56.60 | 100 | Horizontal | Pass |

1 GHz to 25 GHz, ANT V 802.11n20 High Channel

| No. | Frequency (MHz) | Results (dBuV/m) | Factor (dB) | Limit (dBuV/m) | Margin (dB) | Detector | Table (o) | Height (cm) | ANT | Verdict |
|-----|-----------------|------------------|-------------|----------------|-------------|----------|-----------|-------------|----------|---------|
| 1 | 1439.39 | 50.39 | -4.22 | 74.0 | 23.61 | Peak | 42.00 | 100 | Vertical | Pass |
| 2 | 1728.32 | 49.44 | -3.60 | 74.0 | 24.56 | Peak | 153.70 | 100 | Vertical | Pass |
| 3 | 2464.13 | 101.56 | -0.12 | 74.0 | -27.56 | Peak | 61.20 | 100 | Vertical | N/A |
| 4 | 3758.81 | 48.16 | 10.49 | 74.0 | 25.84 | Peak | 50.90 | 100 | Vertical | Pass |
| 5 | 4177.96 | 50.44 | 11.52 | 74.0 | 23.56 | Peak | 312.90 | 100 | Vertical | Pass |
| 6 | 4921.02 | 53.47 | 13.84 | 74.0 | 20.53 | Peak | 6.00 | 100 | Vertical | Pass |
| 7 | 12233.36 | 51.92 | 20.65 | 74.0 | 22.08 | Peak | 0.60 | 100 | Vertical | Pass |
| 8 | 19309.48 | 50.41 | 13.46 | 74.0 | 23.59 | Peak | 56.60 | 100 | Vertical | Pass |

1 GHz to 25 GHz, ANT H 802.11n20 High Channel

| No. | Frequency (MHz) | Results (dBuV/m) | Factor (dB) | Limit (dBuV/m) | Margin (dB) | Detector | Table (o) | Height (cm) | ANT | Verdict |
|-----|-----------------|------------------|-------------|----------------|-------------|----------|-----------|-------------|------------|---------|
| 1 | 1439.39 | 52.66 | -4.22 | 74.0 | 21.34 | Peak | 292.20 | 100 | Horizontal | Pass |
| 2 | 1682.33 | 49.56 | -3.72 | 74.0 | 24.44 | Peak | 10.50 | 100 | Horizontal | Pass |
| 3 | 2460.63 | 117.05 | -0.15 | 74.0 | -43.05 | Peak | 123.30 | 100 | Horizontal | N/A |
| 4 | 3282.68 | 49.12 | 8.89 | 74.0 | 24.88 | Peak | 330.60 | 100 | Horizontal | Pass |
| 5 | 3745.31 | 48.18 | 10.69 | 74.0 | 25.82 | Peak | 177.30 | 100 | Horizontal | Pass |
| 6** | 4922.07 | 42.93 | 13.83 | 54.0 | 11.07 | AV | 163.60 | 100 | Horizontal | Pass |
| 6 | 4922.07 | 57.76 | 13.83 | 74.0 | 16.24 | Peak | 163.60 | 100 | Horizontal | Pass |
| 7 | 12008.74 | 51.91 | 20.87 | 74.0 | 22.09 | Peak | 311.20 | 100 | Horizontal | Pass |
| 8 | 19309.48 | 50.41 | 13.46 | 74.0 | 23.59 | Peak | 56.60 | 100 | Horizontal | Pass |

1 GHz to 25 GHz, ANT V 802.11n40 Low Channel

| No. | Frequency (MHz) | Results (dBuV/m) | Factor (dB) | Limit (dBuV/m) | Margin (dB) | Detector | Table (o) | Height (cm) | ANT | Verdict |
|-----|-----------------|------------------|-------------|----------------|-------------|----------|-----------|-------------|----------|---------|
| 1 | 1440.39 | 51.07 | -4.16 | 74.0 | 22.93 | Peak | 167.00 | 100 | Vertical | Pass |
| 2 | 1689.83 | 49.61 | -3.79 | 74.0 | 24.39 | Peak | 357.00 | 100 | Vertical | Pass |
| 3 | 2419.65 | 101.04 | 0.57 | 74.0 | -27.04 | Peak | 22.00 | 100 | Vertical | N/A |
| 4 | 2821.04 | 51.47 | 2.81 | 74.0 | 22.53 | Peak | 78.00 | 100 | Vertical | Pass |
| 5 | 3974.01 | 49.02 | 11.07 | 74.0 | 24.98 | Peak | 345.00 | 100 | Vertical | Pass |
| 6 | 4678.08 | 52.38 | 13.14 | 74.0 | 21.62 | Peak | 209.00 | 100 | Vertical | Pass |
| 7 | 12413.06 | 51.55 | 20.58 | 74.0 | 22.45 | Peak | 113.70 | 100 | Vertical | Pass |
| 8 | 19309.48 | 50.41 | 13.46 | 74.0 | 23.59 | Peak | 56.60 | 100 | Vertical | Pass |

1 GHz to 25 GHz, ANT H 802.11n40 Low Channel

| No. | Frequency (MHz) | Results (dBuV/m) | Factor (dB) | Limit (dBuV/m) | Margin (dB) | Detector | Table (o) | Height (cm) | ANT | Verdict |
|-----|-----------------|------------------|-------------|----------------|-------------|----------|-----------|-------------|------------|---------|
| 1 | 1439.89 | 52.26 | -4.17 | 74.0 | 21.74 | Peak | 271.00 | 100 | Horizontal | Pass |
| 2 | 1680.33 | 50.12 | -3.51 | 74.0 | 23.88 | Peak | 192.00 | 100 | Horizontal | Pass |
| 3 | 2406.65 | 114.86 | 0.02 | 74.0 | -40.86 | Peak | 256.00 | 100 | Horizontal | N/A |
| 4 | 3229.44 | 50.23 | 9.17 | 74.0 | 23.77 | Peak | 183.00 | 100 | Horizontal | Pass |
| 5 | 3946.26 | 48.04 | 11.03 | 74.0 | 25.96 | Peak | 91.00 | 100 | Horizontal | Pass |
| 6 | 4812.30 | 51.61 | 13.93 | 74.0 | 22.39 | Peak | 183.00 | 100 | Horizontal | Pass |
| 7 | 12233.36 | 51.96 | 20.65 | 74.0 | 22.04 | Peak | -0.40 | 100 | Horizontal | Pass |
| 8 | 19309.48 | 50.41 | 13.46 | 74.0 | 23.59 | Peak | 56.60 | 100 | Horizontal | Pass |

1 GHz to 25 GHz, ANT H 802.11n40 Middle Channel

| No. | Frequency (MHz) | Results (dBuV/m) | Factor (dB) | Limit (dBuV/m) | Margin (dB) | Detector | Table (o) | Height (cm) | ANT | Verdict |
|-----|-----------------|------------------|-------------|----------------|-------------|----------|-----------|-------------|----------|---------|
| 1 | 1439.89 | 52.55 | -4.17 | 74.0 | 21.45 | Peak | 224.00 | 100 | Vertical | Pass |
| 2 | 1724.32 | 47.80 | -3.60 | 74.0 | 26.20 | Peak | 212.00 | 100 | Vertical | Pass |
| 3 | 2433.64 | 100.86 | 0.08 | 74.0 | -26.86 | Peak | 170.00 | 100 | Vertical | N/A |
| 4 | 2797.55 | 51.85 | 2.37 | 74.0 | 22.15 | Peak | 317.00 | 100 | Vertical | Pass |
| 5 | 3609.60 | 47.34 | 10.01 | 74.0 | 26.66 | Peak | 15.00 | 100 | Vertical | Pass |
| 6 | 4306.17 | 50.92 | 11.95 | 74.0 | 23.08 | Peak | 196.00 | 100 | Vertical | Pass |
| 7 | 12323.21 | 52.08 | 20.64 | 74.0 | 21.92 | Peak | 343.50 | 100 | Vertical | Pass |
| 8 | 19309.48 | 50.41 | 13.46 | 74.0 | 23.59 | Peak | 56.60 | 100 | Vertical | Pass |

1 GHz to 25 GHz, ANT H 802.11n40 Middle Channel

| No. | Frequency (MHz) | Results (dBuV/m) | Factor (dB) | Limit (dBuV/m) | Margin (dB) | Detector | Table (o) | Height (cm) | ANT | Verdict |
|-----|-----------------|------------------|-------------|----------------|-------------|----------|-----------|-------------|----------|---------|
| 1 | 1439.89 | 52.86 | -4.17 | 74.0 | 21.14 | Peak | 286.00 | 100 | Vertical | Pass |
| 2 | 1682.83 | 49.36 | -3.69 | 74.0 | 24.64 | Peak | 2.00 | 100 | Vertical | Pass |
| 3 | 2441.14 | 115.29 | 0.24 | 74.0 | -41.29 | Peak | 319.00 | 100 | Vertical | N/A |
| 4 | 2903.02 | 53.21 | 2.90 | 74.0 | 20.79 | Peak | 110.00 | 100 | Vertical | Pass |
| 5 | 3604.35 | 48.76 | 9.97 | 74.0 | 25.24 | Peak | 156.00 | 100 | Vertical | Pass |
| 6 | 4673.58 | 51.79 | 13.17 | 74.0 | 22.21 | Peak | 201.00 | 100 | Vertical | Pass |
| 7 | 12132.28 | 51.66 | 20.73 | 74.0 | 22.34 | Peak | 136.10 | 100 | Vertical | Pass |
| 8 | 19219.63 | 50.78 | 14.00 | 74.0 | 23.22 | Peak | 359.00 | 100 | Vertical | Pass |

1 GHz to 25 GHz, ANT V 802.11n40 High Channel

| No. | Frequency (MHz) | Results (dBuV/m) | Factor (dB) | Limit (dBuV/m) | Margin (dB) | Detector | Table (o) | Height (cm) | ANT | Verdict |
|-----|-----------------|------------------|-------------|----------------|-------------|----------|-----------|-------------|----------|---------|
| 1 | 1440.39 | 53.52 | -4.16 | 74.0 | 20.48 | Peak | 80.00 | 100 | Vertical | Pass |
| 2 | 1797.30 | 48.53 | -3.26 | 74.0 | 25.47 | Peak | 27.00 | 100 | Vertical | Pass |
| 3 | 2461.63 | 99.61 | -0.16 | 74.0 | -25.61 | Peak | 346.00 | 100 | Vertical | N/A |
| 4 | 2864.03 | 51.01 | 2.61 | 74.0 | 22.99 | Peak | 221.00 | 100 | Vertical | Pass |
| 5 | 3801.55 | 48.15 | 10.78 | 74.0 | 25.85 | Peak | 357.00 | 100 | Vertical | Pass |
| 6 | 4833.29 | 52.04 | 13.69 | 74.0 | 21.96 | Peak | 134.00 | 100 | Vertical | Pass |
| 7 | 12323.21 | 52.15 | 20.64 | 74.0 | 21.85 | Peak | 343.50 | 100 | Vertical | Pass |
| 8 | 19309.48 | 51.14 | 13.46 | 74.0 | 22.86 | Peak | 57.90 | 100 | Vertical | Pass |

1 GHz to 25 GHz, ANT H 802.11n40 High Channel

| No. | Frequency (MHz) | Results (dBuV/m) | Factor (dB) | Limit (dBuV/m) | Margin (dB) | Detector | Table (o) | Height (cm) | ANT | Verdict |
|-----|-----------------|------------------|-------------|----------------|-------------|----------|-----------|-------------|----------|---------|
| 1 | 1440.39 | 50.32 | -4.16 | 74.0 | 23.68 | Peak | 8.00 | 100 | Vertical | Pass |
| 2 | 1681.33 | 49.22 | -3.58 | 74.0 | 24.78 | Peak | 232.00 | 100 | Vertical | Pass |
| 3 | 2439.14 | 115.91 | 0.21 | 74.0 | -41.91 | Peak | 195.00 | 100 | Vertical | N/A |
| 4 | 2920.02 | 53.10 | 2.89 | 74.0 | 20.90 | Peak | 272.00 | 100 | Vertical | Pass |
| 5 | 3552.61 | 48.14 | 9.85 | 74.0 | 25.86 | Peak | 202.00 | 100 | Vertical | Pass |
| 6 | 4925.52 | 53.48 | 13.90 | 74.0 | 20.52 | Peak | 253.00 | 100 | Vertical | Pass |
| 7 | 12132.28 | 51.84 | 20.73 | 74.0 | 22.16 | Peak | 136.50 | 100 | Vertical | Pass |
| 8 | 19309.48 | 51.14 | 13.46 | 74.0 | 22.86 | Peak | 57.90 | 100 | Vertical | Pass |

Restricted-band band-edge
 Test Data (ANT 0 + ANT 1)
 802.11b Mode:

LOW CHANNEL, PEAK, AV

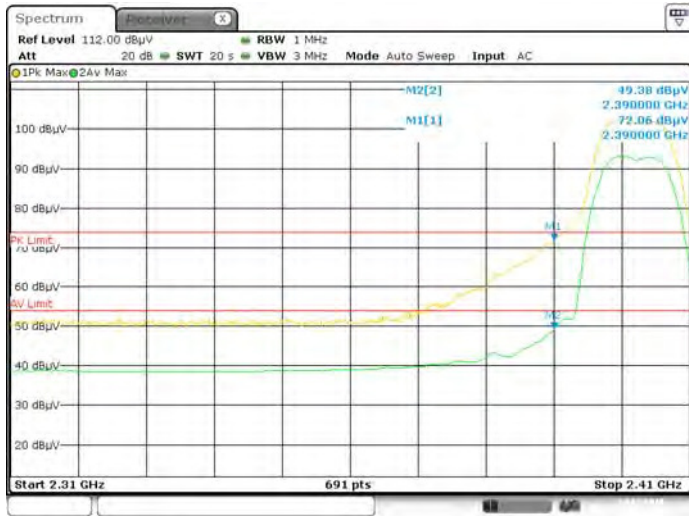

Date: 24,FEB,2016 09:50:55

HIGH CHANNEL, PEAK, AV

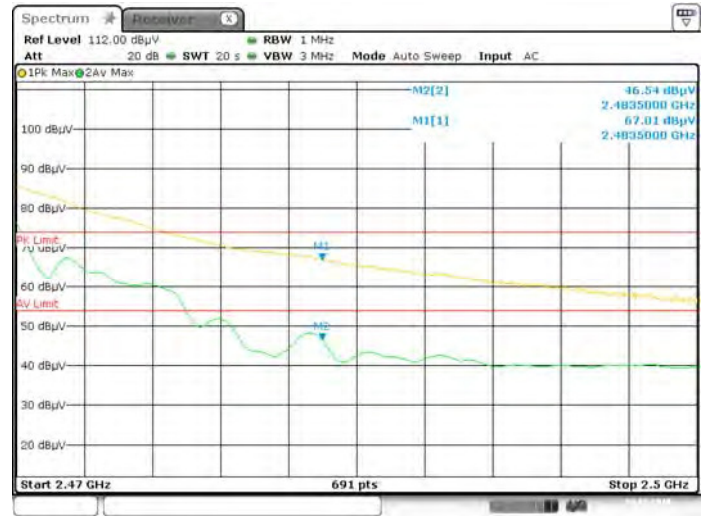

Date: 24,FEB,2016 09:29:56

802.11g Mode:

LOW CHANNEL, PEAK, AV

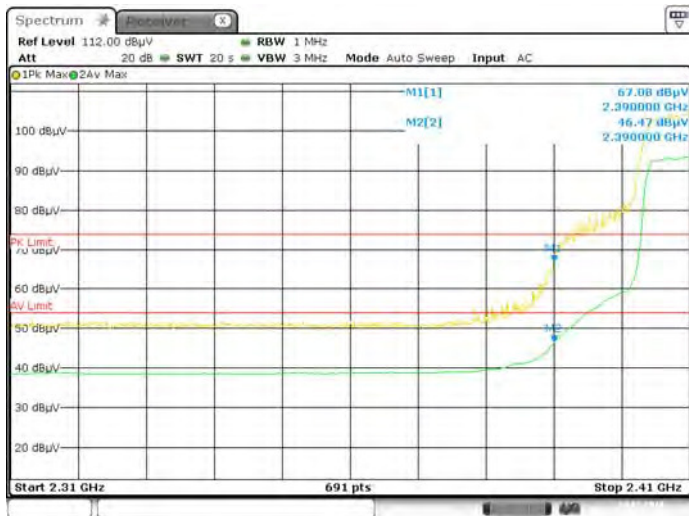

Date: 24,FEB,2016 09:35:02

HIGH CHANNEL, PEAK, AV

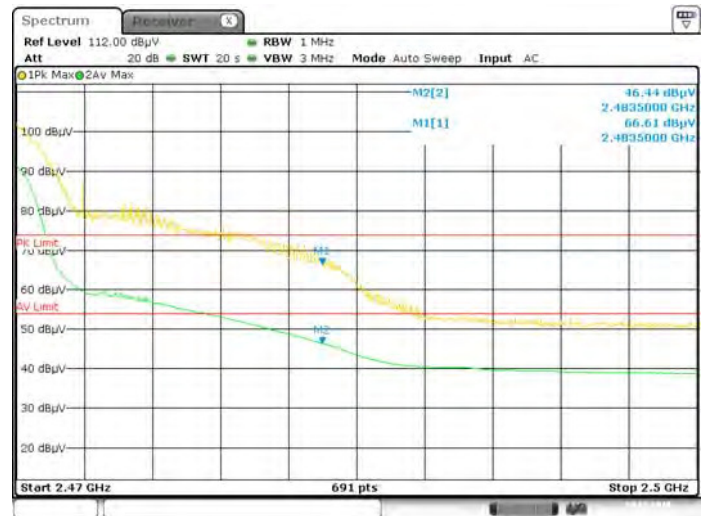

Date: 24,FEB,2016 09:33:40

802.11n-20 MHz Mode:

Low CHANNEL, PEAK, AV

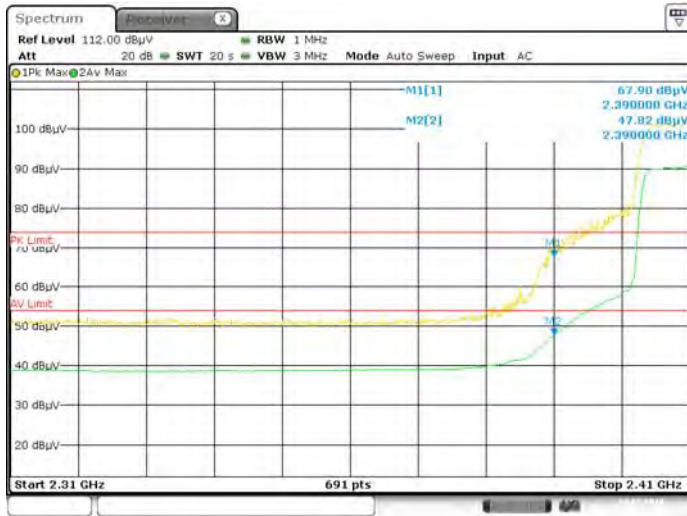

Date: 24.FEB.2016 09:39:23

HIGH CHANNEL, PEAK, AV

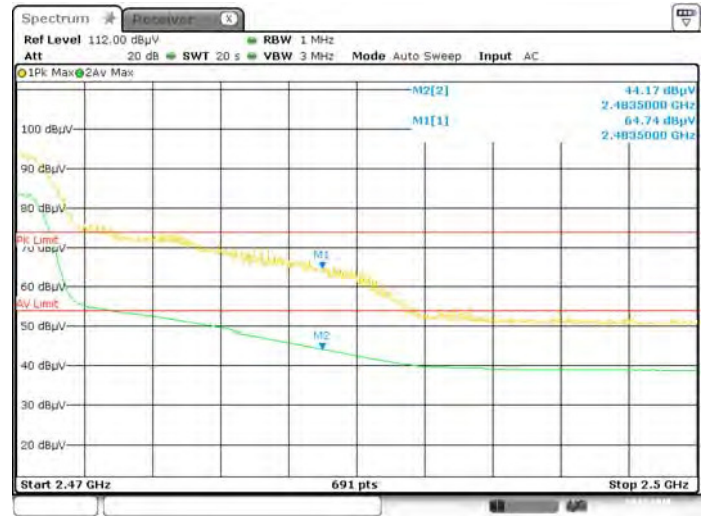

Date: 24.FEB.2016 09:40:05

802.11n-40 MHz Mode:

Low CHANNEL, PEAK, AV

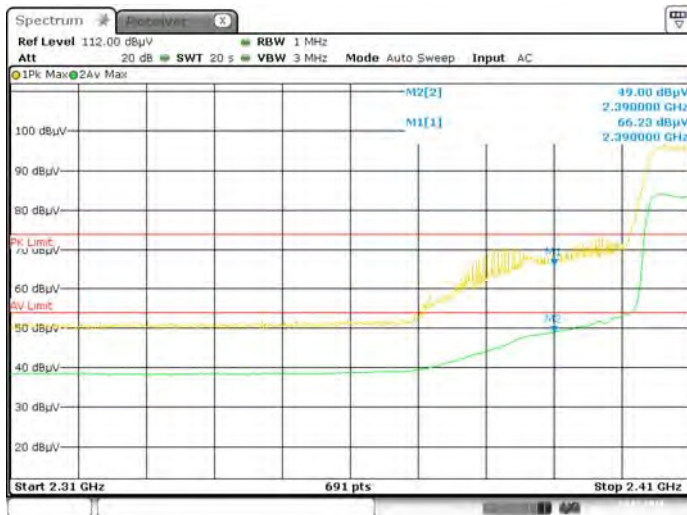

Date: 24.FEB.2016 09:46:19

HIGH CHANNEL, PEAK, AV

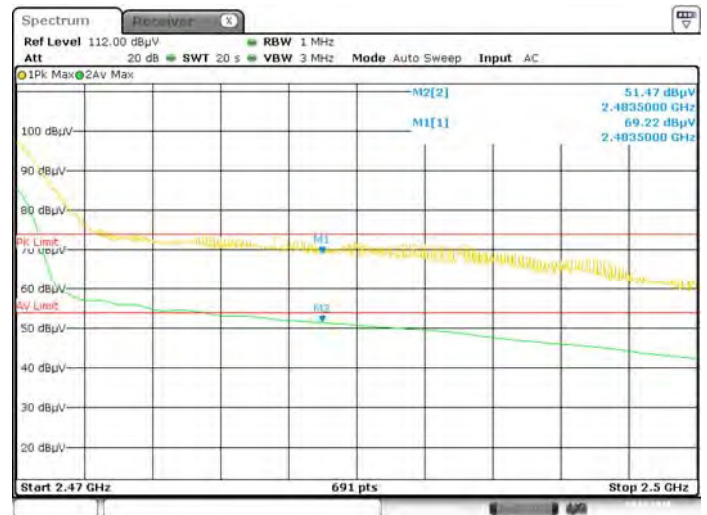

Date: 24.FEB.2016 09:44:33

A.7 Power Spectral Density (PSD)

Test Data

Note: PSD measurements have been summed across the two outputs for conducted measurements, per KDB 662911 D01 v02r01. Which choose method is "Measure and sum spectral maxima across the outputs".

802.11b Mode:

| Channel | Spectral power density (dBm/3kHz) at ANT 0 | Spectral power density (dBm/3kHz) at ANT 1 | Total Spectral power density (dBm/3kHz) | Limit (dBm/3kHz) |
|---------|--|--|---|------------------|
| Low | -7.71 | -7.34 | -4.56 | 8 |
| Middle | -5.70 | -5.36 | -2.52 | 8 |
| High | -7.89 | -6.11 | -3.87 | 8 |

802.11g Mode:

| Channel | Spectral power density (dBm/3kHz) at ANT 0 | Spectral power density (dBm/3kHz) at ANT 1 | Total Spectral power density (dBm/3kHz) | Limit (dBm/3kHz) |
|---------|--|--|---|------------------|
| Low | -8.98 | -7.97 | -5.38 | 8 |
| Middle | -8.94 | -8.66 | -5.85 | 8 |
| High | -8.66 | -9.30 | -6.02 | 8 |

802.11n-20 MHz Mode:

| Channel | Spectral power density (dBm/3kHz) at ANT 0 | Spectral power density (dBm/3kHz) at ANT 1 | Total Spectral power density (dBm/3kHz) | Limit (dBm/3kHz) |
|---------|--|--|---|------------------|
| Low | -7.70 | -9.55 | -5.53 | 8 |
| Middle | -9.02 | -8.80 | -5.85 | 8 |
| High | -8.18 | -8.07 | -5.09 | 8 |

802.11n-40 MHz Mode:

| Channel | Spectral power density (dBm/3kHz) at ANT 0 | Spectral power density (dBm/3kHz) at ANT 1 | Total Spectral power density (dBm/3kHz) | Limit (dBm/3kHz) |
|---------|--|--|---|------------------|
| Low | -9.71 | -8.30 | -5.85 | 8 |
| Middle | -10.15 | -9.30 | -6.58 | 8 |
| High | -11.59 | -8.92 | -6.99 | 8 |

Test plots

ANT 0

802.11b LOW CHANNEL

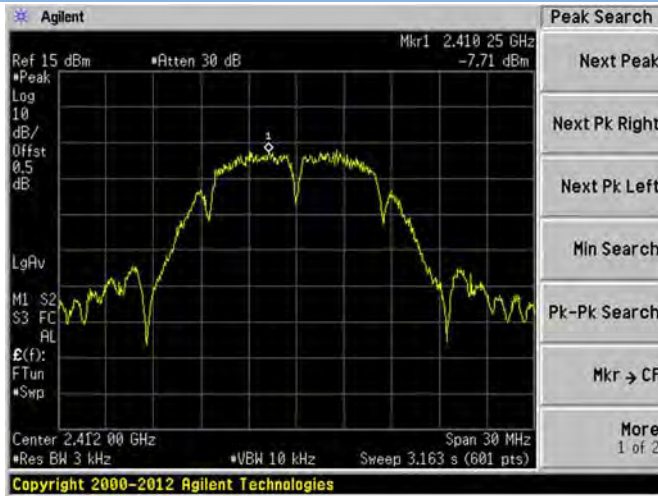

802.11b MIDDLE CHANNEL

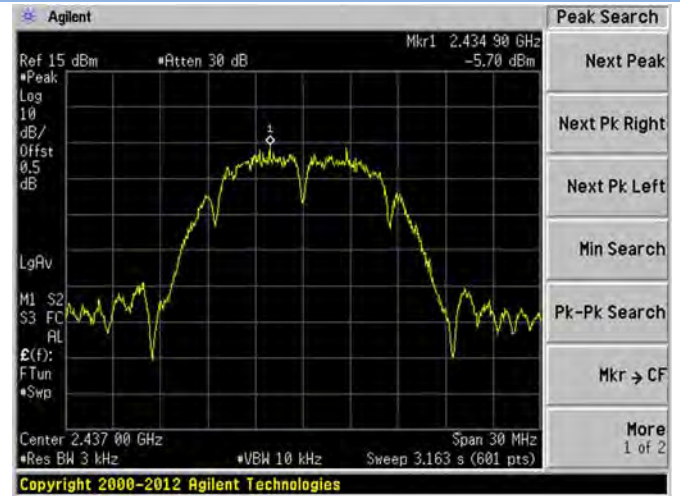

802.11b HIGH CHANNEL

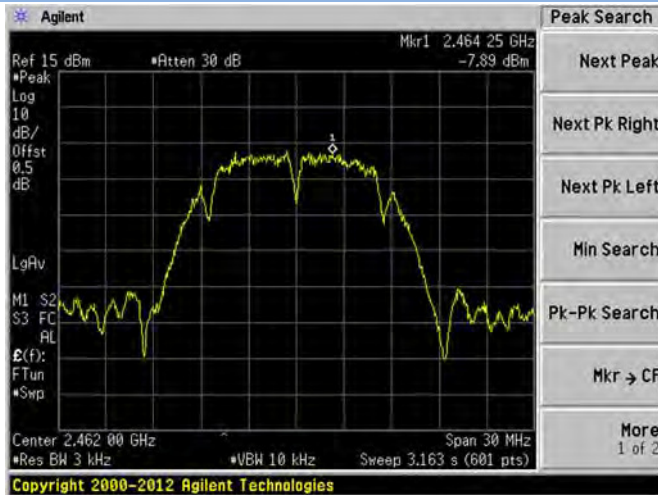

802.11g LOW CHANNEL

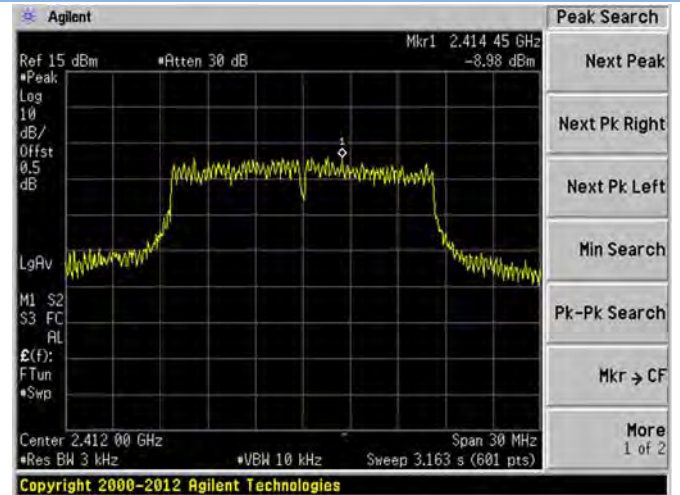

802.11g MIDDLE CHANNEL

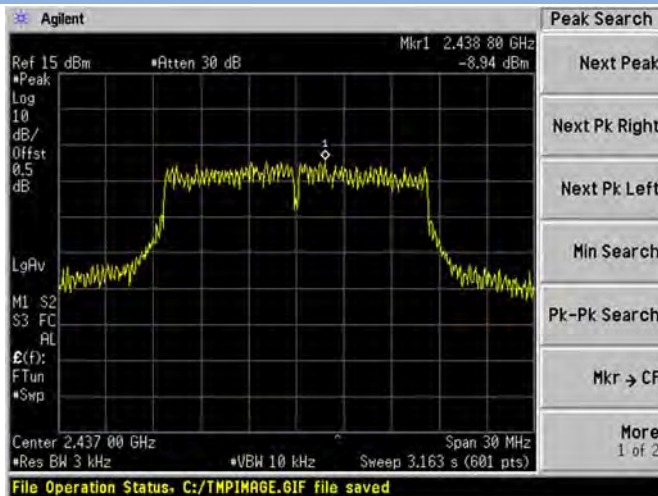

802.11g HIGH CHANNEL

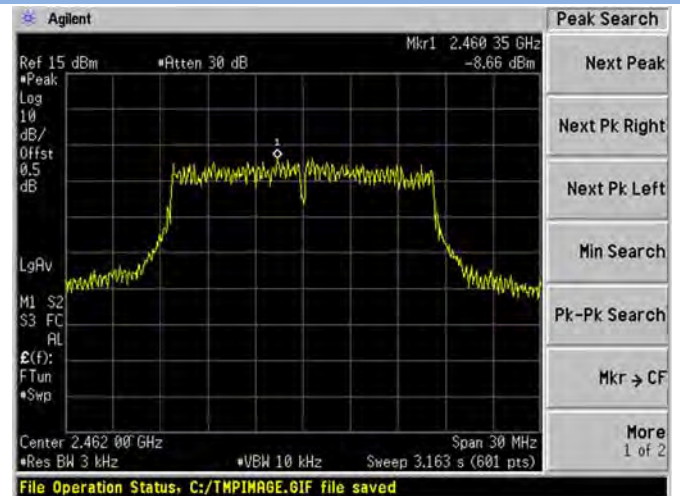

802.11n-20 MHz LOW CHANNEL

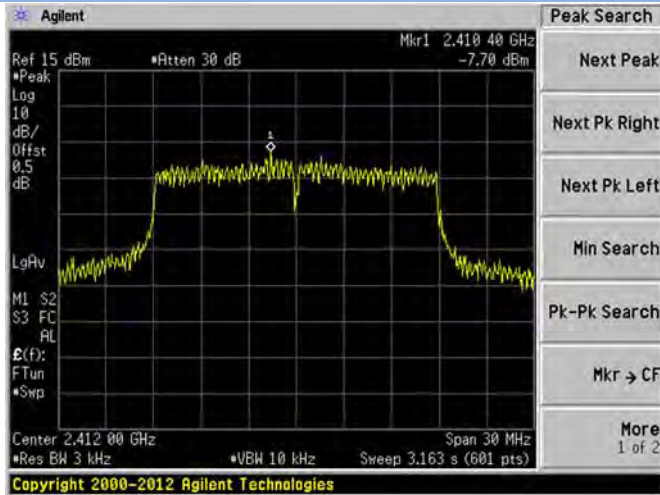

802.11 n-20 MHz MIDDLE CHANNEL

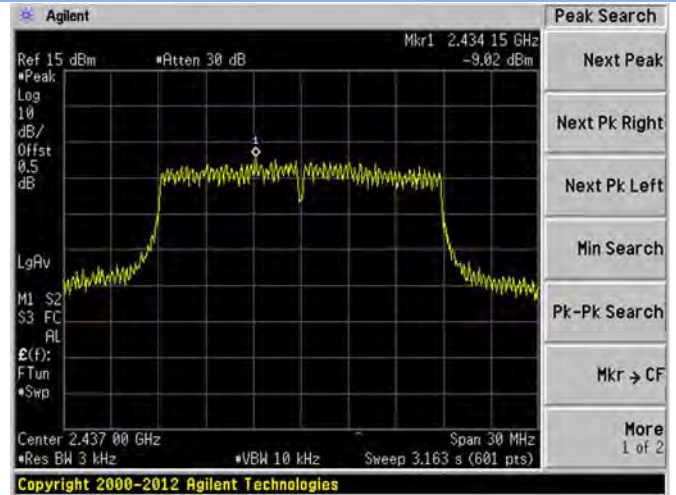

802.11n-20 MHz HIGH CHANNEL

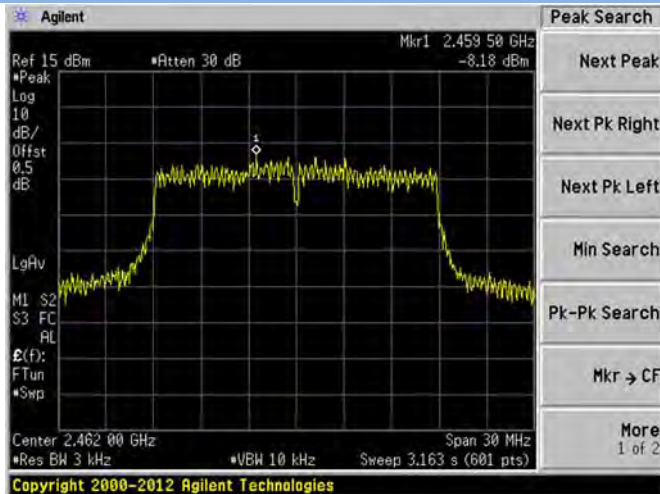

802.11n-40 MHz LOW CHANNEL

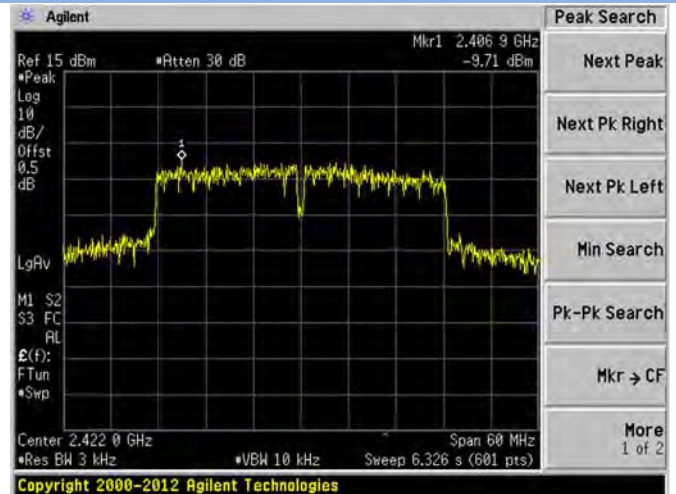

802.11n-40 MHz MIDDLE CHANNEL

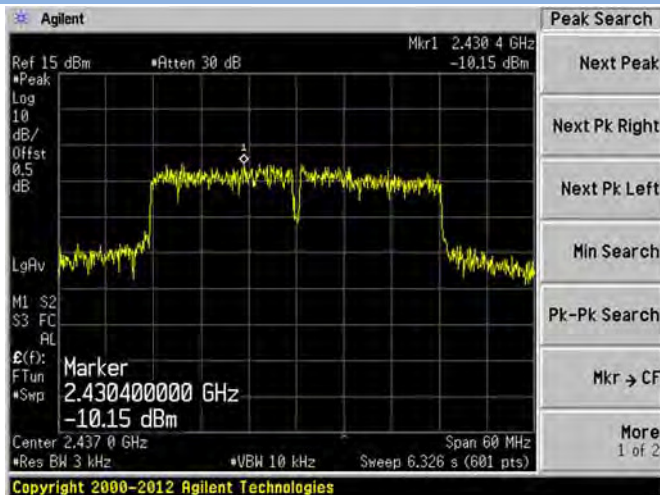

802.11n-40 MHz HIGH CHANNEL

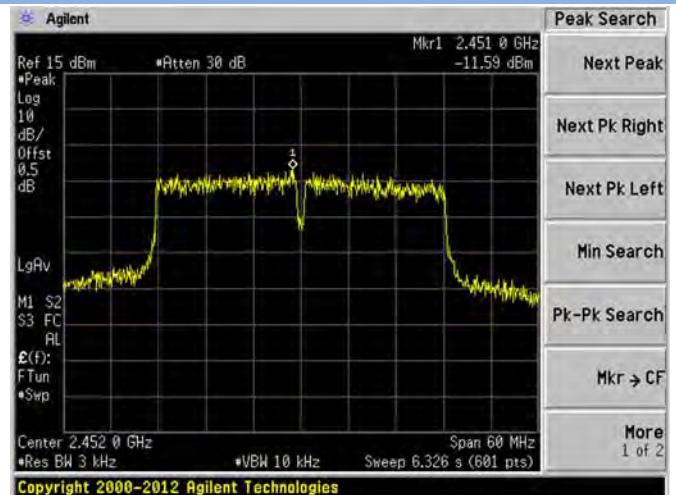

ANT 1

802.11b LOW CHANNEL

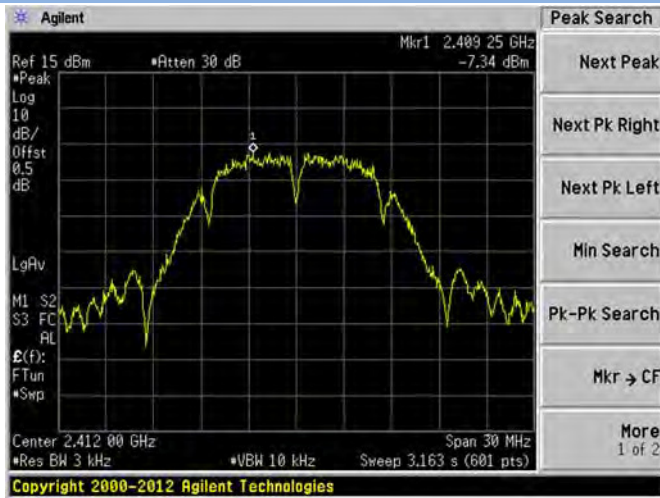

802.11b MIDDLE CHANNEL

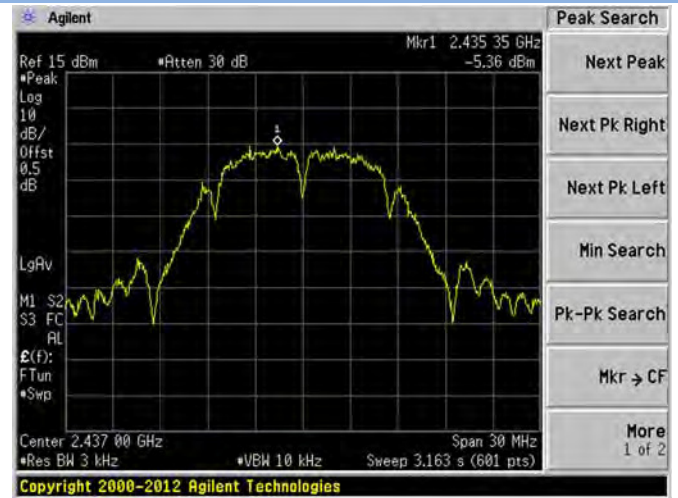

802.11b HIGH CHANNEL

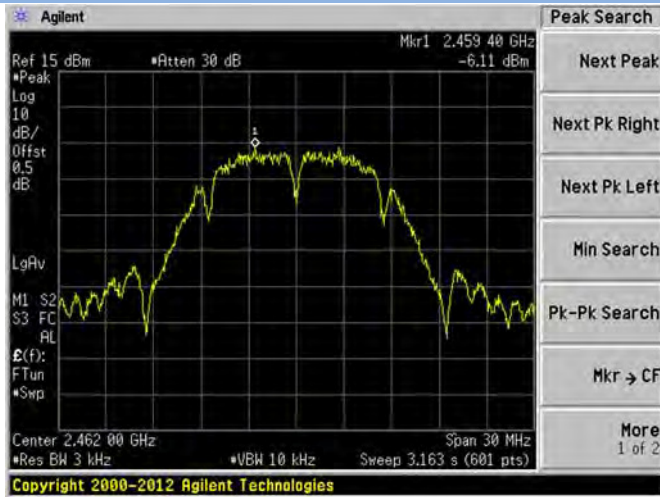

802.11g LOW CHANNEL

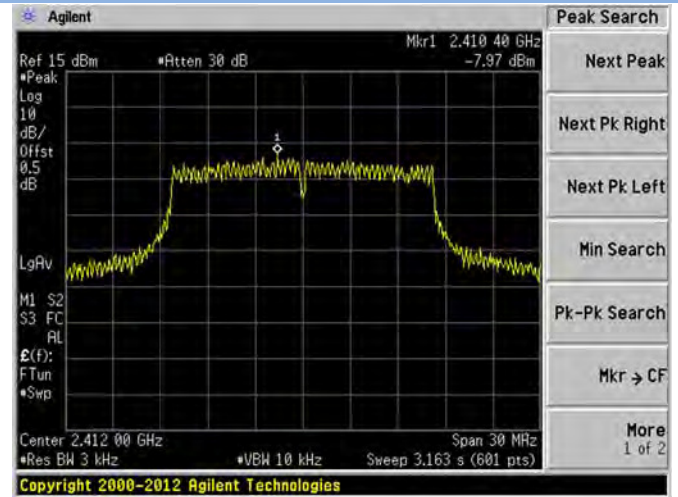

802.11g MIDDLE CHANNEL

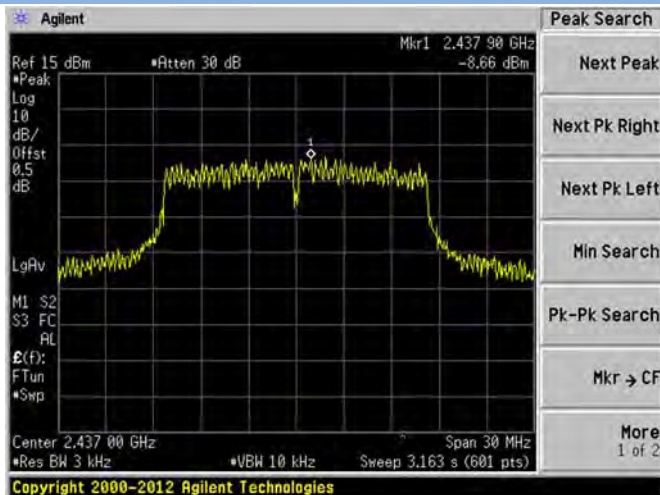

802.11g HIGH CHANNEL

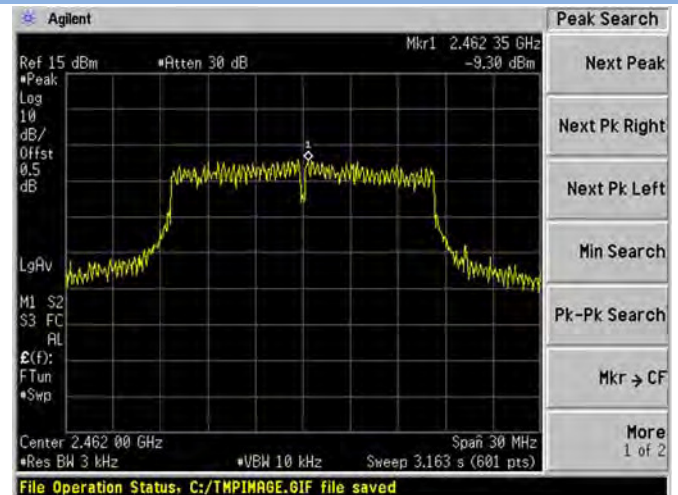

802.11n-20 MHz LOW CHANNEL

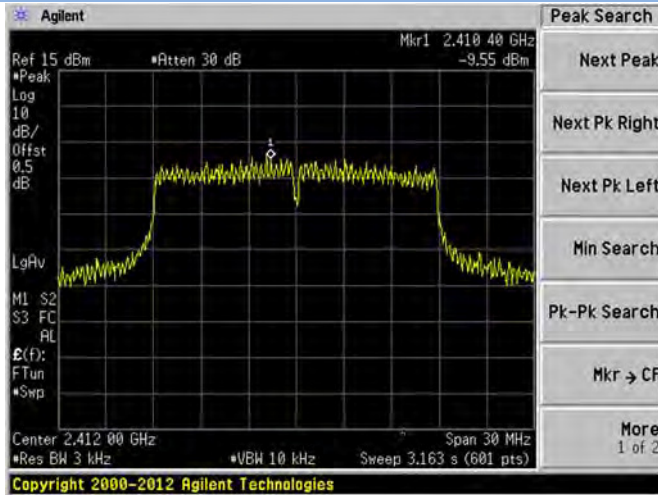

802.11 n-20 MHz MIDDLE CHANNEL

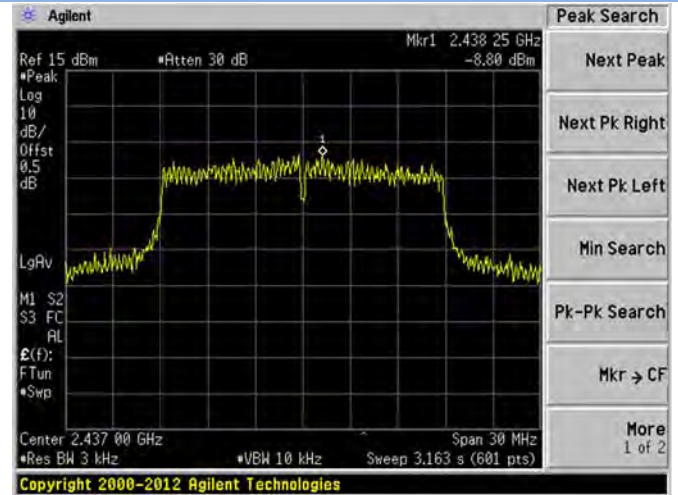

802.11n-20 MHz HIGH CHANNEL

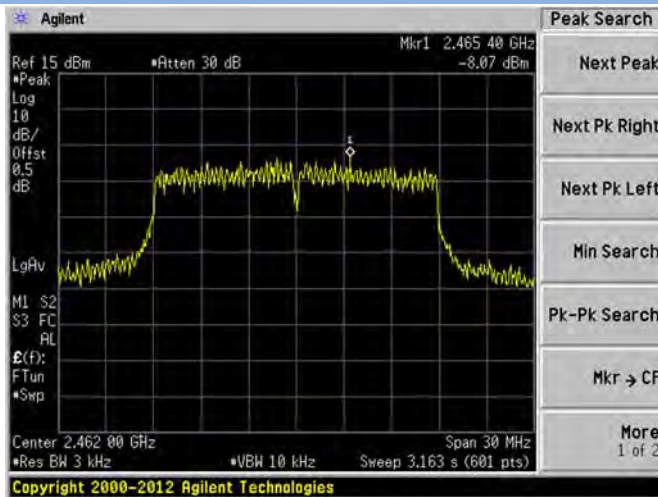

802.11n-40 MHz LOW CHANNEL

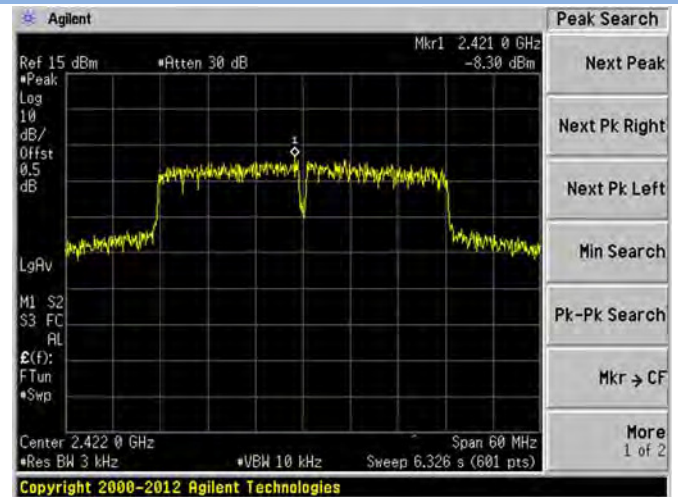

802.11n-40 MHz MIDDLE CHANNEL

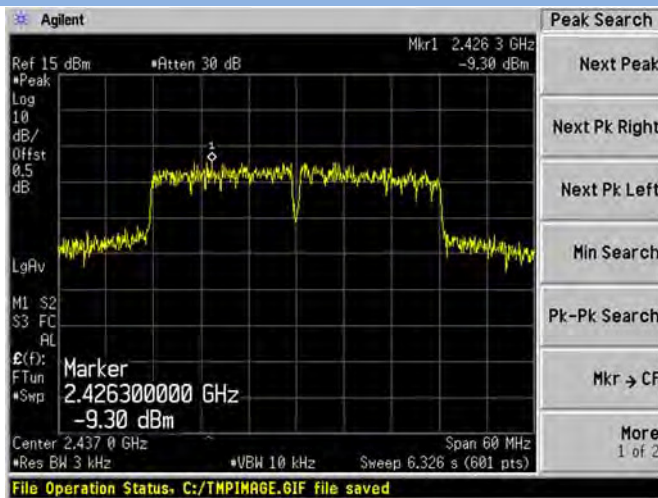

802.11n-40 MHz HIGH CHANNEL

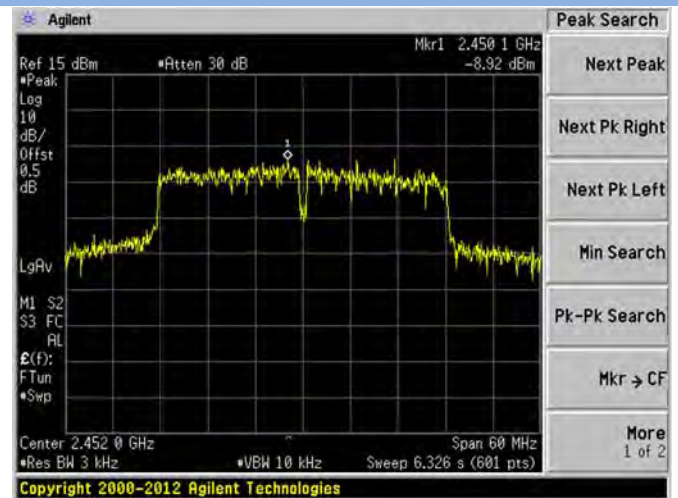

A.8 Receiver Spurious Emissions

Note: All configurations have been tested, only the worst configuration (802.11b High Channel) shown here.

Test Data and Plots

30 MHz to 1 GHz, ANT V

RE Test case_FCC_Part 15C_FCC 15C 30MHz-1GHz

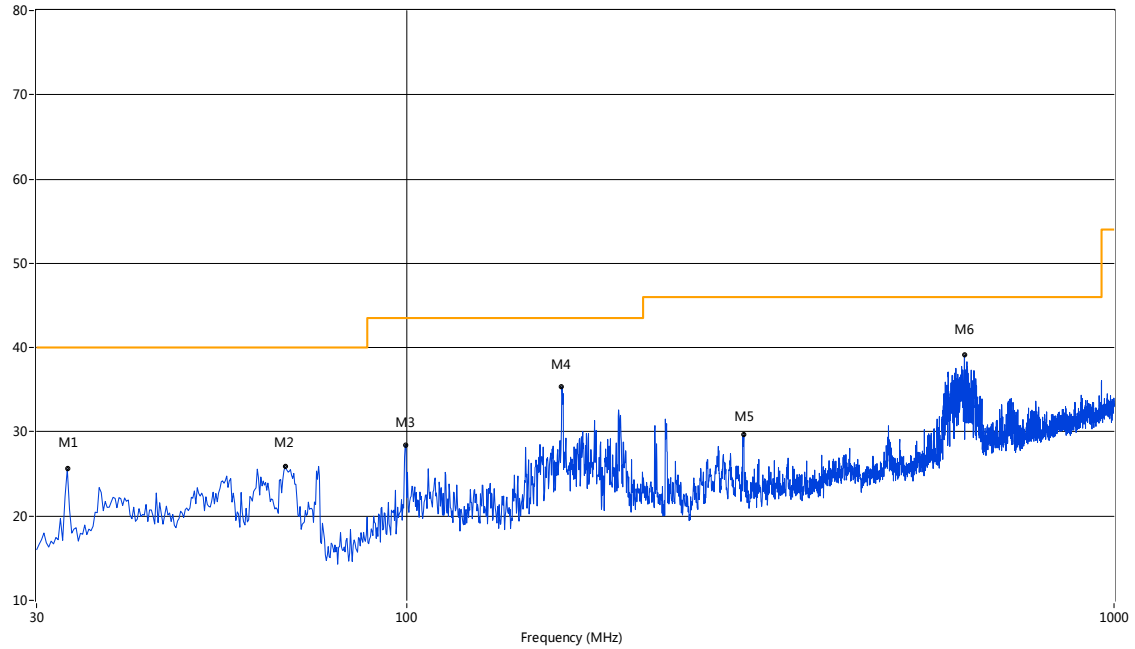

| No. | Frequency (MHz) | Results (dBuV/m) | Factor (dB) | Limit (dBuV/m) | Margin (dB) | Detector | Table (o) | Height (cm) | ANT | Verdict |
|-----|-----------------|------------------|-------------|----------------|-------------|----------|-----------|-------------|----------|---------|
| 1 | 33.15 | 25.59 | -21.9 | 40 | 14.41 | Peak | 242.00 | 100 | Vertical | N/A |
| 1* | 33.15 | 18.15 | -21.9 | 54 | 35.85 | QP | 242.00 | 100 | Vertical | Pass |
| 2 | 67.34 | 25.85 | -21.61 | 40 | 14.15 | Peak | 18.00 | 100 | Vertical | N/A |
| 2* | 67.34 | 17.32 | -21.61 | 54 | 36.68 | QP | 18.00 | 100 | Vertical | Pass |
| 3 | 99.82 | 28.45 | -20.2 | 43.5 | 15.05 | Peak | 118.00 | 100 | Vertical | N/A |
| 3* | 99.82 | 17.91 | -20.2 | 54 | 36.09 | QP | 118.00 | 100 | Vertical | Pass |
| 4 | 165.77 | 35.34 | -22.91 | 43.5 | 8.16 | Peak | 267.00 | 100 | Vertical | N/A |
| 4* | 165.77 | 25.51 | -22.91 | 54 | 28.49 | QP | 267.00 | 100 | Vertical | Pass |
| 5 | 299.59 | 29.66 | -17.64 | 46 | 16.34 | Peak | 47.00 | 100 | Vertical | N/A |
| 5* | 299.59 | 19.32 | -17.64 | 54 | 34.68 | QP | 47.00 | 100 | Vertical | Pass |
| 6 | 614.52 | 39.08 | -10.24 | 46 | 6.92 | Peak | 298.00 | 100 | Vertical | N/A |
| 6* | 614.52 | 28.00 | -10.24 | 54 | 26.00 | QP | 298.00 | 100 | Vertical | Pass |

30 MHz to 1 GHz, ANT H

RE Test case_FCC_Part 15C_FCC 15C 30MHz-1GHz

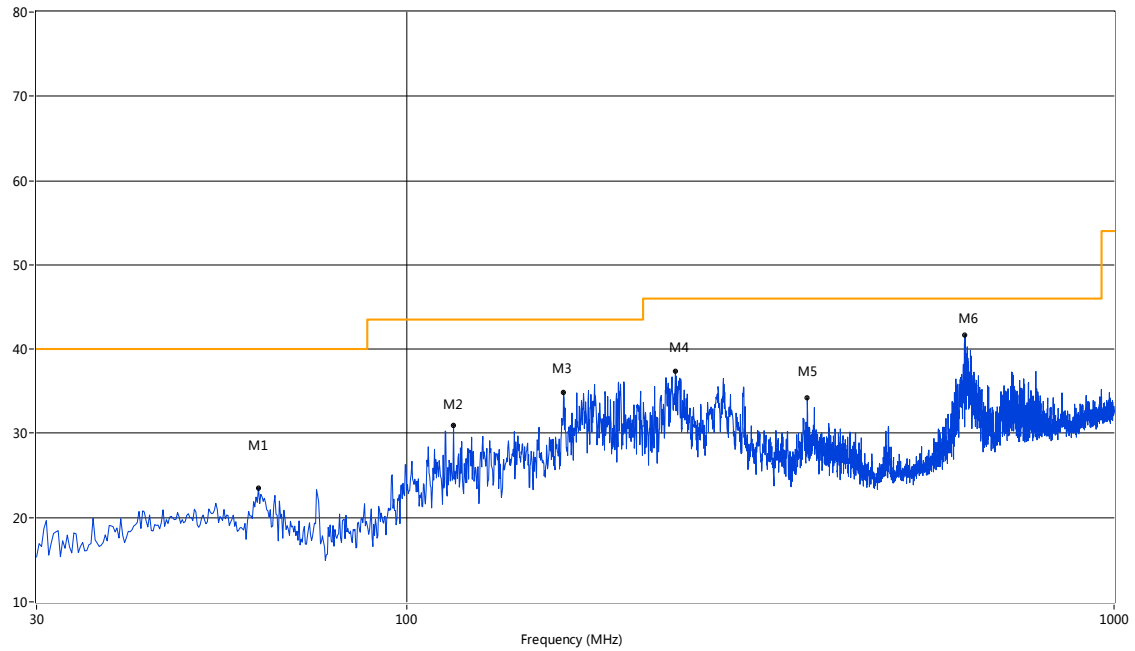

| No. | Frequency (MHz) | Results (dBuV/m) | Factor (dB) | Limit (dBuV/m) | Margin (dB) | Detector | Table (o) | Height (cm) | ANT | Verdict |
|-----|-----------------|------------------|-------------|----------------|-------------|----------|-----------|-------------|------------|---------|
| 1 | 61.76 | 23.51 | -20.29 | 40 | 16.49 | Peak | 342.00 | 100 | Horizontal | N/A |
| 1* | 61.76 | 15.04 | -20.29 | 54 | 38.96 | QP | 342.00 | 100 | Horizontal | Pass |
| 2 | 116.55 | 30.94 | -21.21 | 43.5 | 12.56 | Peak | 4.00 | 100 | Horizontal | N/A |
| 2* | 116.55 | 22.28 | -21.21 | 54 | 31.72 | QP | 4.00 | 100 | Horizontal | Pass |
| 3 | 166.74 | 34.85 | -22.85 | 43.5 | 8.65 | Peak | 172.00 | 100 | Horizontal | N/A |
| 3* | 166.74 | 24.34 | -22.85 | 54 | 29.66 | QP | 172.00 | 100 | Horizontal | Pass |
| 4 | 239.95 | 37.35 | -19.1 | 46 | 8.65 | Peak | 254.00 | 100 | Horizontal | N/A |
| 4* | 239.95 | 28.22 | -19.1 | 54 | 25.78 | QP | 254.00 | 100 | Horizontal | Pass |
| 5 | 368.45 | 34.22 | -16 | 46 | 11.78 | Peak | 122.00 | 100 | Horizontal | N/A |
| 5* | 368.45 | 22.94 | -16 | 54 | 31.06 | QP | 122.00 | 100 | Horizontal | Pass |
| 6 | 615.73 | 41.68 | -10.36 | 46 | 4.32 | Peak | 182.00 | 100 | Horizontal | N/A |
| 6* | 615.73 | 32.67 | -10.36 | 54 | 21.33 | QP | 182.00 | 100 | Horizontal | Pass |

1 GHz to 6 GHz, ANT V

RE Test case_FCC 15C 1GHz-6GHz

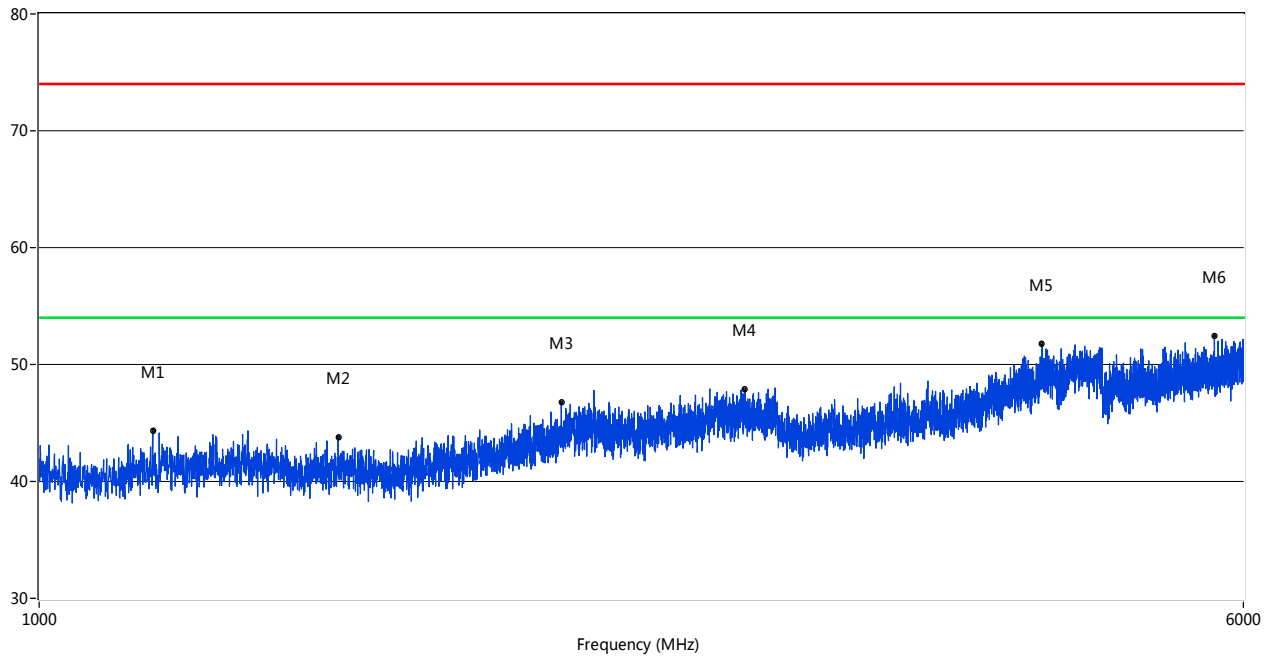

| No. | Frequency (MHz) | Results (dBuV/m) | Factor (dB) | Limit (dBuV/m) | Margin (dB) | Detector | Table (o) | Height (cm) | ANT | Verdict |
|-----|-----------------|------------------|-------------|----------------|-------------|----------|-----------|-------------|----------|---------|
| 1 | 1183.95 | 44.36 | -5.55 | 74.0 | 29.64 | Peak | 125.50 | 100 | Vertical | Pass |
| 2 | 1560.36 | 43.82 | -4.00 | 74.0 | 30.18 | Peak | 55.50 | 100 | Vertical | Pass |
| 3 | 2174.71 | 46.73 | -0.99 | 74.0 | 27.27 | Peak | 358.40 | 100 | Vertical | Pass |
| 4 | 2859.03 | 47.87 | 1.99 | 74.0 | 26.13 | Peak | 2.00 | 100 | Vertical | Pass |
| 5 | 4447.14 | 51.76 | 12.48 | 74.0 | 22.24 | Peak | 171.70 | 100 | Vertical | Pass |
| 6 | 5747.31 | 52.45 | 15.50 | 74.0 | 21.55 | Peak | 232.70 | 100 | Vertical | Pass |

1 GHz to 6 GHz, ANT H

RE Test case_FCC 15C 1GHz-6GHz

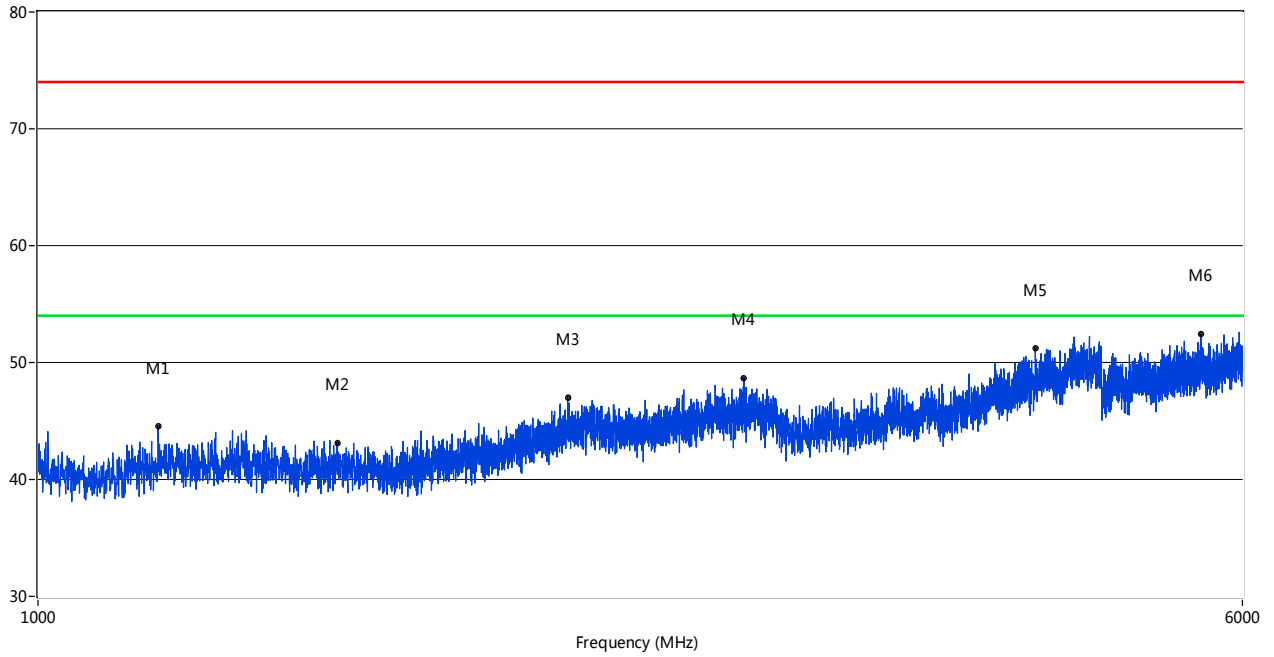

| No. | Frequency (MHz) | Results (dBuV/m) | Factor (dB) | Limit (dBuV/m) | Margin (dB) | Detector | Table (o) | Height (cm) | ANT | Verdict |
|-----|-----------------|------------------|-------------|----------------|-------------|----------|-----------|-------------|------------|---------|
| 1 | 1195.45 | 44.53 | -5.46 | 74.0 | 29.47 | Peak | 251.60 | 100 | Horizontal | Pass |
| 2 | 1560.36 | 43.14 | -4.00 | 74.0 | 30.86 | Peak | 54.70 | 100 | Horizontal | Pass |
| 3 | 2198.70 | 47.00 | -0.46 | 74.0 | 27.00 | Peak | 0.40 | 100 | Horizontal | Pass |
| 4 | 2859.03 | 48.70 | 1.99 | 74.0 | 25.30 | Peak | 2.20 | 100 | Horizontal | Pass |
| 5 | 4409.65 | 51.26 | 12.44 | 74.0 | 22.74 | Peak | 199.70 | 100 | Horizontal | Pass |
| 6 | 5642.34 | 52.40 | 15.56 | 74.0 | 21.60 | Peak | 64.00 | 100 | Horizontal | Pass |

ANNEX B TEST SETUP PHOTOS

Please refer the document "BL-SZ15C0294-AR.pdf"

ANNEX C EUT EXTERNAL PHOTOS

Please refer the document "BL-SZ15C0294-AW.pdf"

ANNEX D EUT INTERNAL PHOTOS

Please refer the document "BL-SZ15C0294-AI.pdf"

--END OF REPORT--