

FCC/IC

RF

TEST REPORT

ISSUED BY
Shenzhen BALUN Technology Co., Ltd.



FOR
Wi-Fi Speaker

ISSUED TO
Dongguan Digital AV Technology Corp., Ltd.

2nd floor F2-S3 district, No.18 Haibin road, Wusha, Changan,
Dongguan, Guangdong

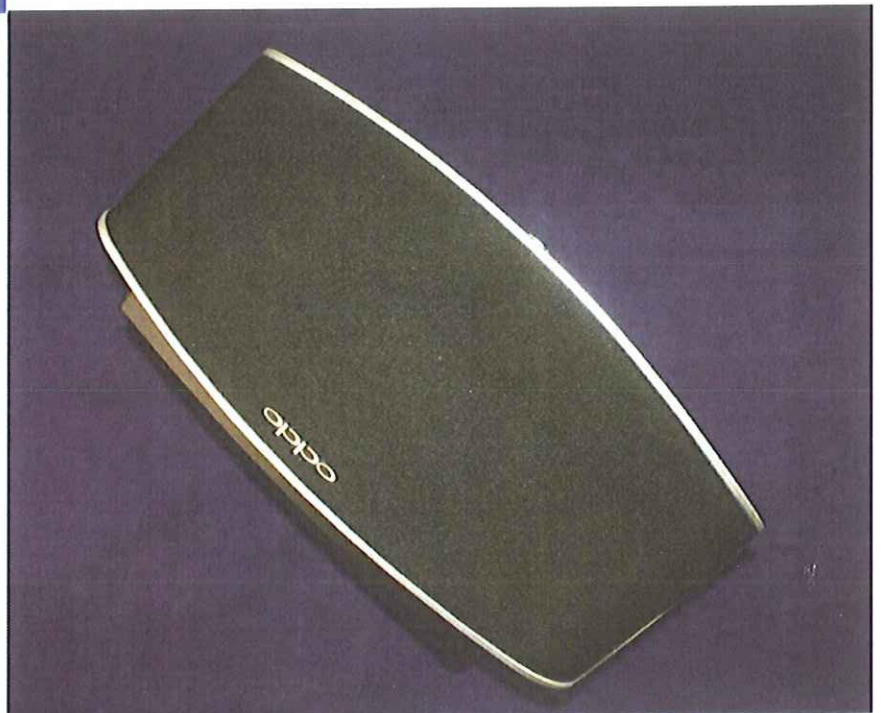

Tested by: 
Cao Shaodong

(Engineer)

Date: Dec. 17, 2015

Approved by: 
Wei Yanquan

(Chief Engineer)

Date: Dec. 17, 2015



Report No.: BL-SZ15B0132-605

EUT Type: Wi-Fi Speaker

Model Name: Sonica

Brand Name: OPPO

Test Standard: 47 CFR Part 15 Subpart E
IC RSS-247 (Issue 1, May 2015)

FCC ID: 2AGM4-SONICA

IC Number: 20960-SONICA

Test conclusion: Pass

Test Date: Nov. 15, 2015 ~ Nov. 26, 2015

Date of Issue: Dec. 17, 2015

NOTE: This test report can be duplicated completely for the legal use with the approval of the applicant; it shall not be reproduced except in full, without the written approval of Shenzhen BALUN Technology Co., Ltd. BALUN Laboratory. Any objections should be raised within thirty days from the date of issue. To validate the report, please visit BALUN website.

Revision History

<u>Version</u>	<u>Issue Date</u>	<u>Revisions</u>
<u>Rev. 01</u>	<u>Dec. 17, 2015</u>	<u>Initial Issue</u>
_____	_____	_____

TABLE OF CONTENTS

1	ADMINISTRATIVE DATA (GENERAL INFORMATION)	4
1.1	Identification of the Testing Laboratory	4
1.2	Identification of the Responsible Testing Location	4
1.3	Laboratory Condition	4
1.4	Announce	4
2	PRODUCT INFORMATION	6
2.1	Applicant Information	6
2.2	Manufacturer Information	6
2.3	Factory Information	6
2.4	General Description for Equipment under Test (EUT)	6
2.5	Ancillary Equipment	6
2.6	Technical Information	6
3	SUMMARY OF TEST RESULTS.....	8
3.1	Test Standards.....	8
3.2	Verdict.....	8
3.3	Test Uncertainty	8
4	GENERAL TEST CONFIGURATIONS.....	9
4.1	Test Environments	9
4.2	Test Equipment List	9
4.3	Description of Test Setup.....	10
4.3.1	Conducted Test Setup Configuration	10
5	Test Type and Test Results.....	11
5.1	DFS.....	11
5.1.1	U-NII DFS Rule Requirements	11
5.1.2	Utest Limits and Radar Signal Parameters	11

ANNEX A TEST RESULT 15

 A.1 CHANNEL CLOSING TRANSMISSION AND CHANNEL MOVE TIME..... 15

 A.2 NON- OCCUPANCY PERIOD 17

ANNEX B TEST SETUP PHOTOS 18

ANNEX C EUT EXTERNAL PHOTOS 18

ANNEX D EUT INTERNAL PHOTOS 18

1 ADMINISTRATIVE DATA (GENERAL INFORMATION)

1.1 Identification of the Testing Laboratory

Company Name	Shenzhen BALUN Technology Co., Ltd.
Address	Block B, 1st FL, Baisha Science and Technology Park, Shahe Xi Road, Nanshan District, Shenzhen, Guangdong Province, P. R. China
Phone Number	+86 755 6685 0100
Fax Number	+86 755 6182 4271

1.2 Identification of the Responsible Testing Location

Test Location	Shenzhen BALUN Technology Co., Ltd.
Address	Block B, 1st FL, Baisha Science and Technology Park, Shahe Xi Road, Nanshan District, Shenzhen, Guangdong Province, P. R. China
Accreditation Certificate	<p>The laboratory has been listed by Industry Canada to perform electromagnetic emission measurements. The recognition numbers of test site are 11524A-1.</p> <p>The laboratory has been listed by US Federal Communications Commission to perform electromagnetic emission measurements. The recognition numbers of test site are 832625.</p> <p>The laboratory has met the requirements of the IAS Accreditation Criteria for Testing Laboratories (AC89), has demonstrated compliance with ISO/IEC Standard 17025:2005. The accreditation certificate number is TL-588.</p> <p>The laboratory is a testing organization accredited by China National Accreditation Service for Conformity Assessment (CNAS) according to ISO/IEC 17025. The accreditation certificate number is L6791.</p>
Description	All measurement facilities used to collect the measurement data are located at Block B, FL 1, Baisha Science and Technology Park, Shahe Xi Road, Nanshan District, Shenzhen, Guangdong Province, P. R. China 518055

1.3 Laboratory Condition

Ambient Temperature	20 to 25°C
Ambient Relative Humidity	45% - 55%
Ambient Pressure	100 kPa - 102 kPa

1.4 Announce

- (1) The test report reference to the report template version v1.0.
- (2) The test report is invalid if not marked with the signatures of the persons responsible for preparing and approving the test report.
- (3) The test report is invalid if there is any evidence and/or falsification.

- (4) The results documented in this report apply only to the tested sample, under the conditions and modes of operation as described herein.
- (5) This document may not be altered or revised in any way unless done so by BALUN and all revisions are duly noted in the revisions section.
- (6) Content of the test report, in part or in full, cannot be used for publicity and/or promotional purposes without prior written approval from the laboratory.

2 PRODUCT INFORMATION

2.1 Applicant Information

Applicant	Dongguan Digital AV Technology Corp., Ltd.
Address	2nd floor F2-S3 district, No.18 Haibin road, Wusha, Changan, Dongguan, Guangdong

2.2 Manufacturer Information

Manufacturer	Dongguan Digital AV Technology Corp., Ltd.
Address	2nd floor F2-S3 district, No.18 Haibin road, Wusha, Changan, Dongguan, Guangdong

2.3 Factory Information

Factory	Dongguan Digital AV Technology Corp., Ltd.
Address	2nd floor F2-S3 district, No.18 Haibin road, Wusha, Changan, Dongguan, Guangdong

2.4 General Description for Equipment under Test (EUT)

EUT Type	Wi-Fi Speaker
Under Test Model Name	Sonica
Hardware Version	1.0
Software Version	Linux 3.10.26
Network and Wireless connectivity	Bluetooth 3.0, Bluetooth 4.0 Low Energy (BLE) WIFI 802.11a, 802.11b, 802.11g, 802.11n(HT20/40) and 802.11ac

2.5 Ancillary Equipment

Ancillary Equipment 1	Power Cable	
	Brand Name	N/A
	Model No.	N/A
	Length(Approx.)	1.7 m

2.6 Technical Information

The requirement for the following technical information of the EUT was tested in this report:

Frequency Range	5150 MHz to 5350 MHz, 5470 MHz to 5850 MHz	
Maximum Output Power	5150 MHz to 5350 MHz: 19.15 dBm 5470 MHz to 5850 MHz: 19.38 dBm	
Antenna Type	Antenna 0 (ANT 0) Antenna 1 (ANT 1)	PCB Antenna
Antenna Gain	Antenna 0 (ANT 0) Antenna 1 (ANT 1)	5250 MHz to 5350 MHz: 6.4 dBi 5470 MHz to 5725 MHz: 5.3 dBi 5250 MHz to 5350 MHz: 3.2 dBi 5470 MHz to 5725 MHz: 3.3 dBi
About the Product	The equipment is Wi-Fi Speaker, intended for used with information technology equipment.	

ANT 0+Ant 1

Frequency Band (MHz)	Mode	MAXIMUM CONDUCTED POWER		MAXIMUM EIRP POWER	
		Output Power(dBm)	Output Power(mW)	Output Power(dBm)	Output Power(mW)
5250~5350	802.11a	16.15	41.20	22.06	160.53
	802.11n HT20	16.55	45.19	22.44	175.29
	802.11n HT40	17.44	32.31	23.32	214.85
	802.11ac HT20	17.29	53.62	23.16	206.87
	802.11ac HT40	19.15	82.24	25.04	319.48
	802.11ac HT80	13.79	23.91	19.68	92.87
5470~5725	802.11a	16.50	44.68	19.75	94.46
	802.11n HT20	16.87	48.59	20.12	102.71
	802.11n HT40	17.37	54.59	20.62	115.41
	802.11ac HT20	17.02	50.38	20.27	106.44
	802.11ac HT40	19.38	86.68	22.63	183.30
	802.11ac HT80	11.24	26.76	17.22	52.76

This device (Client) is without radar detection, then the manufacturer statement confirming that information regarding the parameters of the detected Radar Waveforms is not available to the end user. And the device doesn't have Ad Hoc mode on DFS frequency band.

3 SUMMARY OF TEST RESULTS

3.1 Test Standards

No.	Identity	Document Title
1	47 CFR Part 15 Subpart E	Unlicensed National Information Infrastructure Devices
2	IC RSS-247 (Issue 1, May 2015)	Digital Transmission Systems (DTSs), Frequency Hopping Systems(FHSs) and Licence-Exemp Local Area Network (LE-LAN) Devices
3	KDB Publication 905462 D02v01	UNII DFS Compliance Procedures New Rules

3.2 Verdict

FCC/IC Standard Rule	Description	Result	Remark
FCC 15.407 RSS-247, 6.3	Channel Move Time	Pass	Applicable
FCC 15.407 RSS-247, 6.3	Channel Closing Transmission Time	Pass	Applicable
FCC 15.407 RSS-247, 6.3	Non- Occupancy Period	Pass	Applicable

3.3 Test Uncertainty

The following measurement uncertainty levels have been estimated for tests performed on the EUT as specified in CISPR 16-4-2. This uncertainty represents an expanded uncertainty expressed at approximately the 95% confidence level using a coverage factor of k=2.

Measurement	Value
Conducted emissions (9 KHz-30 MHz)	2.79 dB
Radiated emissions (30 MHz-1 GHz)	3.45 dB
Radiated emissions (1 GHz-18 GHz)	3.67 dB

4 GENERAL TEST CONFIGURATIONS

4.1 Test Environments

During the measurement, the normal environmental conditions were within the listed ranges:

Relative Humidity	45% - 55%	
Atmospheric Pressure	100 kPa - 102 kPa	
Temperature	NT (Normal Temperature)	+22°C to +25°C
	LT (Low Temperature)	-20°C
	HT (High Temperature)	+55°C
Working Voltage of the EUT	NV (Normal Voltage)	120 V
	LV (Low Voltage)	100 V
	HV (High Voltage)	240 V

4.2 Test Equipment List

Description	Manufacturer	Model	Serial No.	Cal. Date	Cal. Due
Spectrum Analyzer	ROHDE&SCHWARZ	FSV-30	103118	2015.07.16	2016.07.15
Vector Signal Generator	ROHDE&SCHWARZ	SMBV100A	177746	2015.07.16	2016.07.15
Signal Generator	ROHDE&SCHWARZ	SMB100A	260592	2015.07.01	2016.06.30
Switch Unit with OSP-B157	ROHDE&SCHWARZ	OSP120	101270	2015.07.16	2016.07.15
Spectrum Analyzer	AGILENT	E4440A	MY45304434	2015.10.18	2016.10.17
Spectrum Analyzer	ROHDE&SCHWARZ	FSL3	103640/003	2015.07.01	2016.06.30
Bluetooth Tester	ROHDE&SCHWARZ	CBT	101005	2015.07.16	2016.07.15
Power Splitter	KMW	DCPD-LDC	1305003215	2015.07.01	2016.06.30
Power Sensor	ROHDE&SCHWARZ	NRP-Z21	103971	2015.07.21	2016.07.20
DC Power Supply	ROHDE&SCHWARZ	HMP2020	018141664	2015.07.17	2016.07.16
Temperature Chamber	ANGELANTIONI SCIENCE	NTH64-40A	1310	2015.08.07	2016.08.06
Test Antenna-Loop(9kHz-30MHz)	SCHWARZBECK	FMZB 1519	1519-037	2015.07.22	2017.07.21
Test Antenna-Bi-Log(30MHz-3GHz)	SCHWARZBECK	VULB 9163	9163-624	2015.07.22	2017.07.21
Test Antenna-Horn(1-18GHz)	SCHWARZBECK	BBHA 9120D	9120D-1148	2015.07.22	2017.07.21
GPS/GLONASS Vector signal generator	R&S	N5172B EXG	N/A	2015.07.16	2016.07.15
Anechoic Chamber	RAINFORD	9m*6m*6m	N/A	2015.02.28	2016.02.27

Master	Access Point	
	Brand Name	Aerohive
	Model No.	AP230
	Serial No.	AH-AP-230-AC-W
	SPEC.	The maximum EIRP is 18.5dBm, Antenna Gain is 6.57dBi

4.3 Description of Test Setup

4.3.1 Conducted Test Setup Configuration

Client without Radar Detection Mode

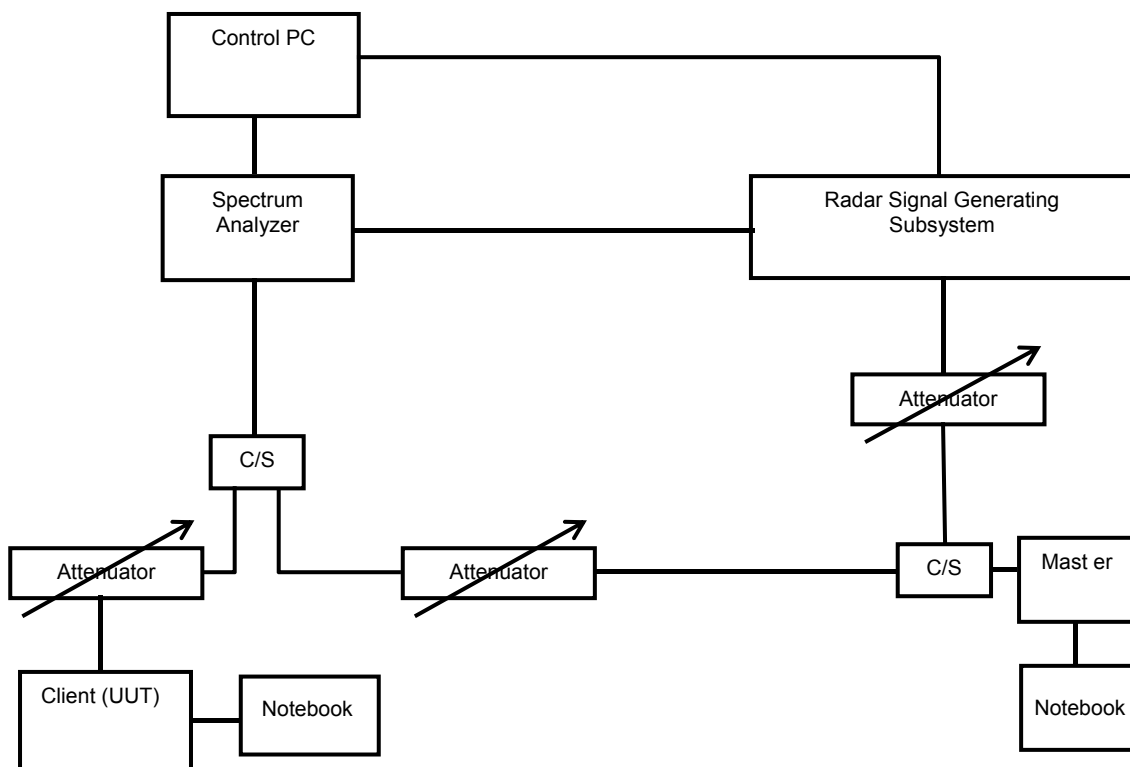

The UUT is a U-NII Device operating in Client mode without radar detection. The radar test signals are injected into the Master Device.

(Diagram 1)

5 Test Type and Test Results

5.1 DFS

5.1.1 U-NII DFS Rule Requirements

5.1.1.1 Working Mode and Required Test Items

The manufacturer shall state whether the UUT is capable of operating as a Master and/or a Client. If the UUT is capable of operating in more than one operating mode then each operating mode shall be tested separately. See tables 1 and 2 for the applicability of DFS requirements for each of the operational modes.

APPLICABILITY OF DFS REQUIREMENTS PRIOR TO USE A CHANNEL

Requirement	Operational Mode		
	Master	Client without radar detection	Client with radar detection
Non-Occupancy Period	✓	✓	✓
DFS Detection Threshold	✓	Not required	✓
Channel Availability Check Time	✓	Not required	Not required
Uniform Spreading	✓	Not required	Not required
U-NII Detection Bandwidth	✓	Not required	✓

APPLICABILITY OF DFS REQUIREMENTS DURING NORMAL OPERATION

Requirement	Operational Mode		
	Master	Client without radar detection	Client with radar detection
DFS Detection Threshold	✓	Not required	✓
Channel Closing Transmission Time	✓	✓	✓
Channel Move Time	✓	✓	✓
U-NII Detection Bandwidth	✓	Not required	✓

5.1.2 Utest Limits and Radar Signal Parameters

Detection Threshold Values

DFS DETECTION THRESHOLDS FOR MASTER DEVICES AND CLIENT DEVICES WITH RADAR DETECTION

Maximum Transmit Power	Value (See Note 1 and 2)
≥ 200 milliwatt	-64 dBm
< 200 milliwatt	-62 dBm

Note 1: This is the level at the input of the receiver assuming a 0 dBi receive antenna.

Note 2: Throughout these test procedures an additional 1 dB has been added to the amplitude of the test transmission waveforms to account for variations in measurement equipment. This will ensure that the test signal is at or above the detection threshold level to trigger a DFS response.

DFS RESPONSE REQUIREMENT VALUES

Parameter	Value
Non-occupancy period	Minimum 30 minutes
Channel Availability Check Time	60 seconds
Channel Move Time	10 seconds See Note 1.
Channel Closing Transmission Time	200 milliseconds + an aggregate of 60 milliseconds over remaining 10 second period. See Notes 1 and 2.
U-NII Detection Bandwidth	100% of the UNII transmission power bandwidth. See Note 3.
<p>Note 1: The instant that the Channel Move Time and the Channel Closing Transmission Time begins is as follows:</p> <ul style="list-style-type: none"> • For the Short Pulse Radar Test Signals this instant is the end of the Burst. • For the Frequency Hopping radar Test Signal, this instant is the end of the last radar Burst generated. • For the Long Pulse Radar Test Signal this instant is the end of the 12 second period defining the Radar Waveform. <p>Note 2: The Channel Closing Transmission Time is comprised of 200 milliseconds starting at the beginning of the Channel Move Time plus any additional intermittent control signals required to facilitate a Channel move (an aggregate of 60 milliseconds) during the remainder of the 10 second period. The aggregate duration of control signals will not count quiet periods in between transmissions.</p> <p>Note 3: During the U-NII Detection Bandwidth detection test, radar type 1 is used and for each frequency step the minimum percentage of detection is 90 percent. Measurements are performed with no data traffic.</p>	

Parameters of DFS Test Signals

Step intervals of 0.1 microsecond for Pulse Width, 1 microsecond for PRI, 1 MHz for chirp width and 1 for the number of pulses will be utilized for the random determination of specific test waveforms.

SHORT PULSE RADAR TEST WAVEFORMS

Radar Type	Pulse Width (µsec)	PRI (µsec)	Number of Pulses	Minimum Percentage of Successful Detection	Minimum Number of Trials
1	1	1428	18	60%	30
2	1-5	150-230	23-29	60%	30
3	6-10	200-500	16-18	60%	30
4	11-20	200-500	12-16	60%	30
Aggregate (Radar Types 1-4)				80%	120

LONG PULSE RADAR TEST WAVEFORM

Radar Type	Pulse Width (μsec)	Chirp Width (MHz)	PRI (μsec)	Number of Pulses per Burst	Number of Bursts	Minimum Percentage of Successful Detection	Minimum Number of Trials
5	50-100	5-20	1000-2000	1-3	8-20	80%	30

FREQUENCY HOPPING RADAR TEST WAVEFORM

Radar Type	Pulse Width (μsec)	PRI (μsec)	Pulses per Hop	Hopping Rate (kHz)	Hopping Sequence Length (msec)	Minimum Percentage of Successful Detection	Minimum Number of Trials
6	1	333	9	0.333	300	70%	30

5.1.2.1 Test Setup

See 4.3 for test setup description for the radiated test. The photo of test setup please refer to ANNEX B.

5.1.2.2 Test Procedure

BVADT DFS MEASUREMENT SYSTEM:

A complete BVADT DFS Measurement System consists of two subsystems: (1) the Radar Signal Generating Subsystem and (2) the Traffic Monitoring Subsystem. The control PC is necessary for generating the Radar waveforms in Table 6, 7 and 8. The traffic monitoring subsystem is specified to the type of unit under test (UUT).

Conducted setup configuration of ADT DFS Measurement System

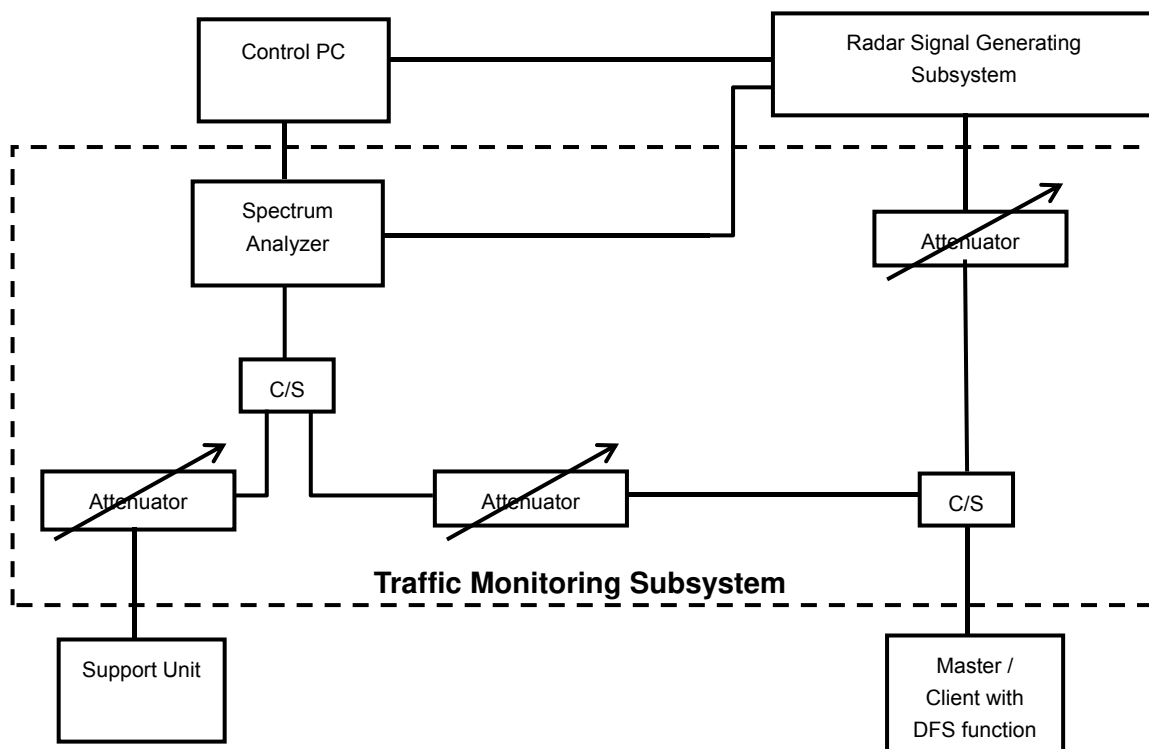

The test transmission will always be from the Master Device to the Client Device. While the Client device is set up to associate with the Master device and play the MPEG file (6 ½ Magic Hours) from Master device, the designated MPEG test file and instructions are located at: <http://ntiacsd.ntia.doc.gov/dfs/>.

CALIBRATION OF DFS DETECTION THRESHOLD LEVEL:

The measured channel is 5500 MHz in 20MHz Bandwidth and 5530MHz in 80MHz Bandwidth. The radar signal was the same as transmitted channels, and injected into the antenna port of AP (master) or Client Device with Radar Detection, measured the channel closing transmission time and channel move time. The Master antenna gain is 6.57dBi and required detection threshold is -54.43dBm (= -62 +1 +6.57)dBm. The calibrated conducted detection threshold level is set to -54.43 dBm.

Conducted setup configuration of Calibration of DFS Detection Threshold Level

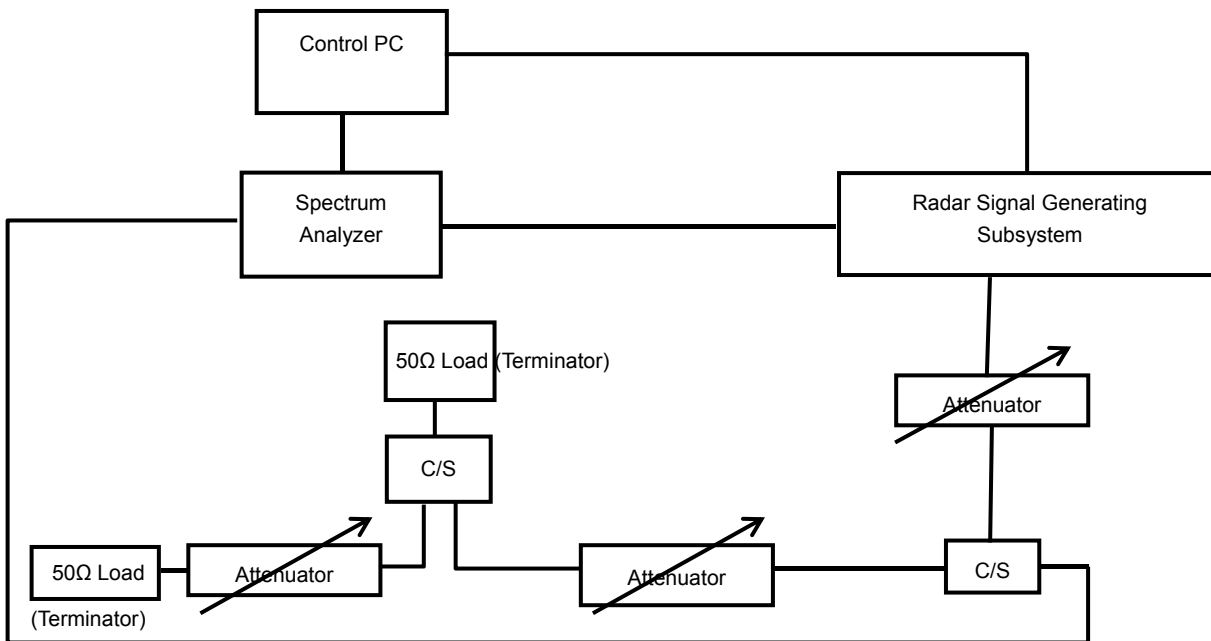

5.1.2.3 Test Result

Please refer to ANNEX A

ANNEX A TEST RESULT

A.1 CHANNEL CLOSING TRANSMISSION AND CHANNEL MOVE TIME

Result of DFS Channel Shutdown

Note: The radar test signals are injected into the Master Device.

This test was investigated for different bandwidth (the lowest and the highest bandwidth). The following plots was done on 80MHz as a representative

Description	Operation Mode	Operation Channel	Value (s)	Limit
Channel Move Time	802.11ac(80 MHz)	58	3.7	10 s
Channel Closing Transmission Time	802.11ac(80 MHz)	58	0.060	1 s
Channel Move Time	802.11ac(80 MHz)	106	6.2	10 s
Channel Closing Transmission Time	802.11ac(80 MHz)	106	0.063	1 s
Test Verdict	Pass			

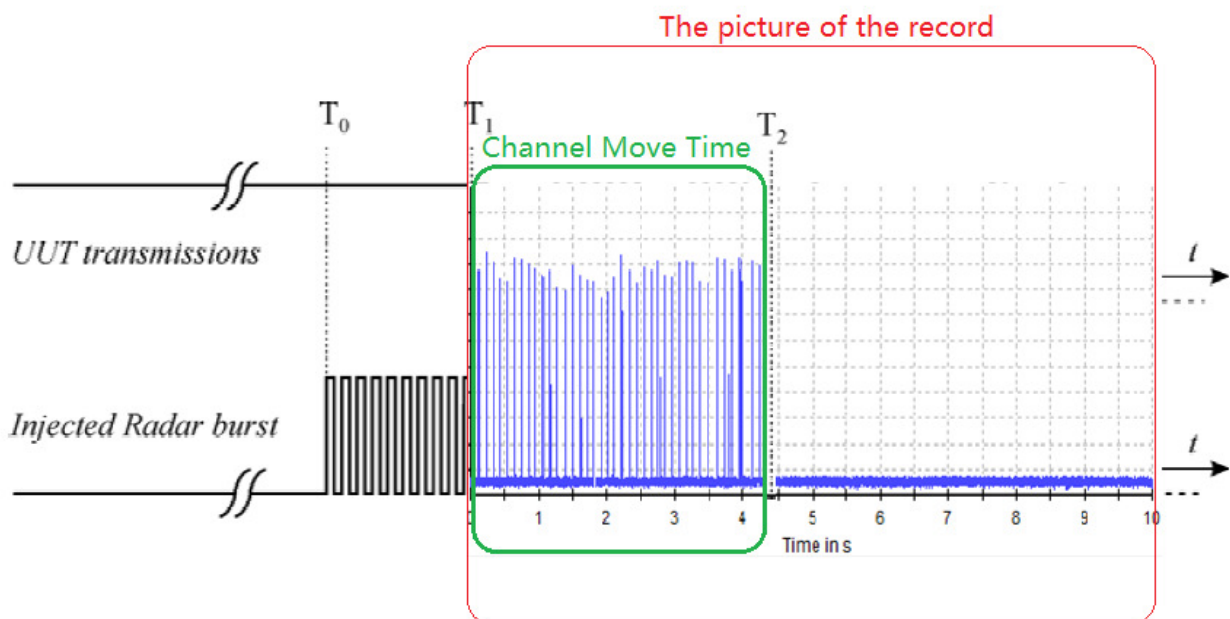

T0 denotes DFS test signal start generated on the channel.

T1 denotes the end of the radar burst.

T2 denotes the instant when the UUT has ceased all transmissions on the channel.

The time difference between T1 and T2 shall be measured. This value (*Channel Move Time*) shall be noted and compared with the limit.

The aggregate duration (*Channel Closing Transmission Time*) of all transmissions from the UUT on Chr during the *Channel Move Time* shall be compared to the limit.

Adaptivity Test schematic graphic

802.11ac Channel 58

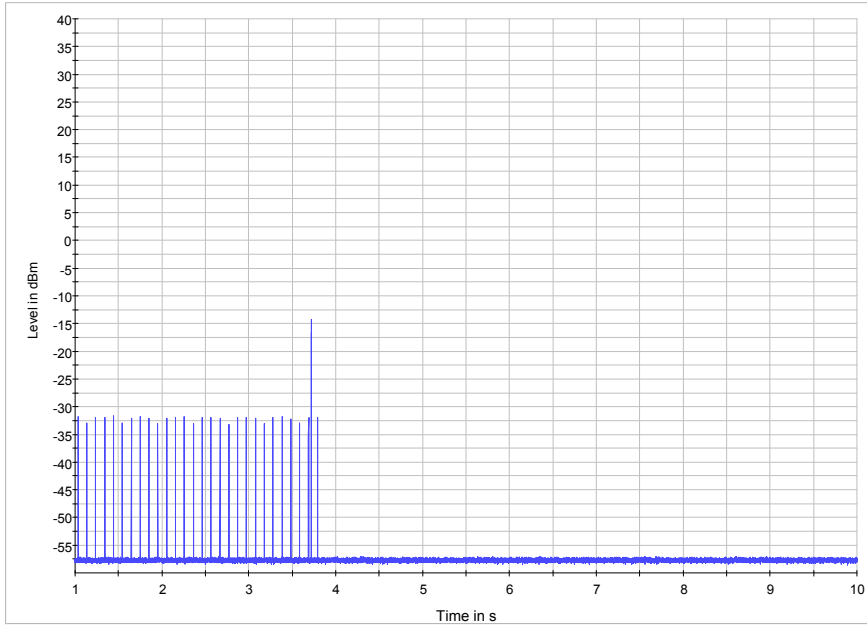

802.11ac 80 Channel 106

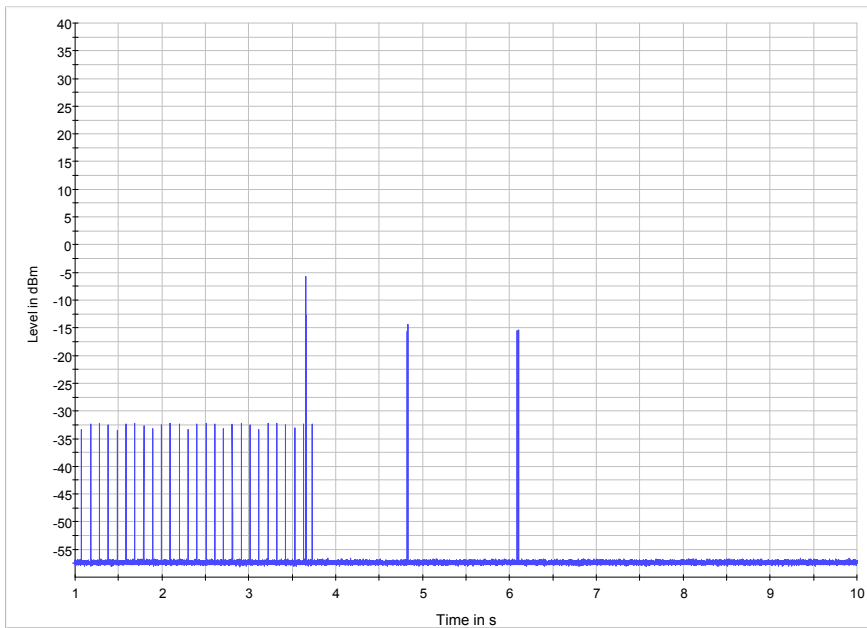

A.2 NON- OCCUPANCY PERIOD

Master was off.

During the 30 minutes observation time, The UUT did not make any transmissions in the DFS band after UUT power up.

802.11ac (80 MHz) CH58

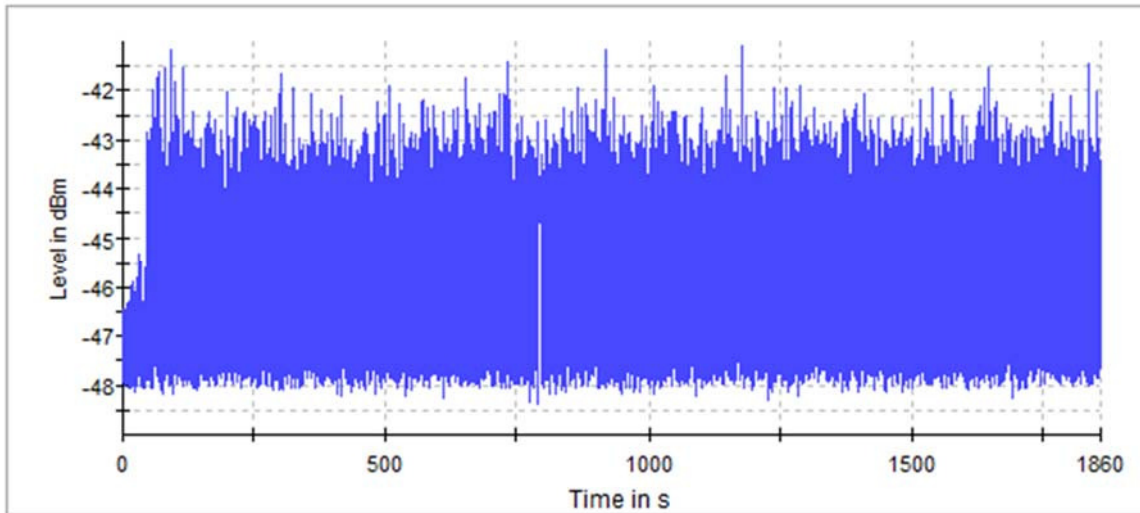

ANNEX B TEST SETUP PHOTOS

Please refer the document "BL-SZ15B0132-DFS.PDF".

ANNEX C EUT EXTERNAL PHOTOS

Please refer the document "BL-SZ15B0132-AW.PDF".

ANNEX D EUT INTERNAL PHOTOS

Please refer the document "BL-SZ15B0132-AI.PDF".

--END OF REPORT--