



Excellence in Compliance Testing

Certification Exhibit

**FCC ID: 2AGLL-AFERO-DB-01
IC: 20929-AFERODB01**

**FCC Rule Part: 15.247
IC Radio Standards Specification: RSS-247**

ACS Project Number: 15-0230

**Manufacturer: Afero Inc
Model: AFERO-DB-01**

Manual



Modulo User Guide

Part Number: AFERO-DB-01

Rev: 1.0

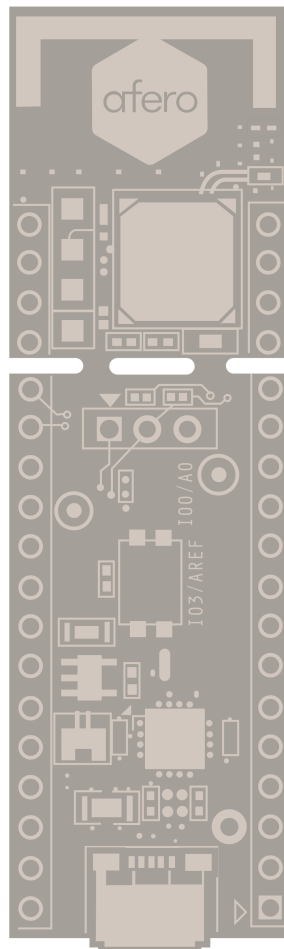



Contents

Contents	2
1 Overview	3
1.1 About Afero	3
1.2 Intro to Modulo	4
1.3 Specification	5
1.4 Block Diagram	6
1.5 Acronyms	6
2	7
2.1 Pin Configuration	7
2.1.1 Pinout Diagram Top View	7
2.1.2 Pin descriptions	8
3 DC Electrical Specification	9
3.1 Typical Power Consumption	9
3.2 GPIO Specification	9
3.2.1 Digital I/O Characteristics	9
3.3 SPI Interface	11
3.3.1 SPI Slave Specification	11
3.3.1.1 Slave Characteristics	11
3.3.1.2 SPI Slave Timing Diagram, One Byte Transmission, SPI Mode 0	11
3.3.1.3 SPI Slave Timing Parameters	12
3.4 UART Interface	13
3.4.1 UART Interface Parameters	13
3.5 ADC/Comparator Interface	14
3.5.1 Auxiliary ADC Characteristics	15
4 Environmental Specification.....	16
4.1 Absolute Maximum Rating	16
4.2 Recommended Operating Condition	16
5 Regulatory information	16
5.1 FCC	17
5.2 Industry Canada	17
5.3 FCC Labeling Requirements	18
5.4 IC Labeling Requirements	18



1 Overview

1.1 About Afero

Afero builds integrated hardware, software, and cloud services for IoT connectivity and data analytics. The Afero turnkey platform incorporates a secure Bluetooth® Smart module, scalable cloud services, and a range of development tools that enable companies and developers to quickly prototype and build connected devices.

The Afero platform is vertically integrated, giving developers a solution that combines security and connectivity at the three key touch points for all connected devices:

- Product (embedded secure radio module)
- Mobile application (app-level monitoring and control)
- Cloud services (web APIs)

This vertical integration accelerates the creation of connected devices by minimizing the investment normally required for software development and testing – while ensuring a secure and scalable solution.

The Afero Secure Radio module (ASR-1, Murata P/N AFERO-BL24-01) comes programmed with authentication, encryption, and connection management software, ensuring a reliable connection to the Afero Cloud. The Afero mobile application, available for both Android and iOS phones, allows users to manage their smart devices and services from their phone.

Developers wanting to build or prototype connected products Powered by Afero can choose from the following options:

- An Afero Modulo development board (P/N: AFERO-DB-01), to be used standalone or in conjunction with an external board equipped with its own microcontroller.
- An Afero Plinto development board (P/N: AFERO-DB-02), to be used in conjunction with an Arduino board.
- A standalone ASR-1 (P/N: AFERO-BL24-01), to be directly integrated into a product and used either standalone (multiple I/O ports provided) or used in conjunction with a host microcontroller.

Afero development boards and tools are available at developer.afero.io.

1.2 Intro to Modulo

Modulo is the demonstration platform board for the Afero ASR-1 module. ASR-1 is a Bluetooth® Smart wireless technology module. It enables ultra-low power connectivity for data communication. The ASR-1 integrates Bluetooth® Smart wireless technology IC, security IC, RF front end, and crystal into a very small package.

The Modulo is designed to attach directly to a Teensy (3.1 or better) board, or to a standard Arduino Shield board, through the use of an Afero Plinto Shield board (sold separately).

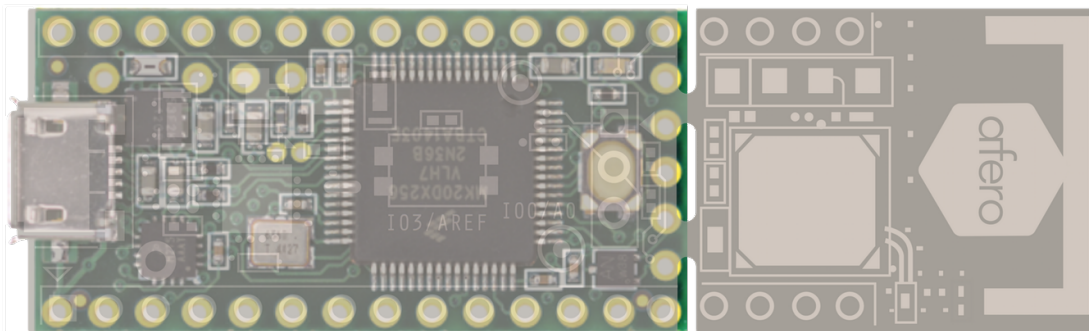

Modulo-Teensy connections

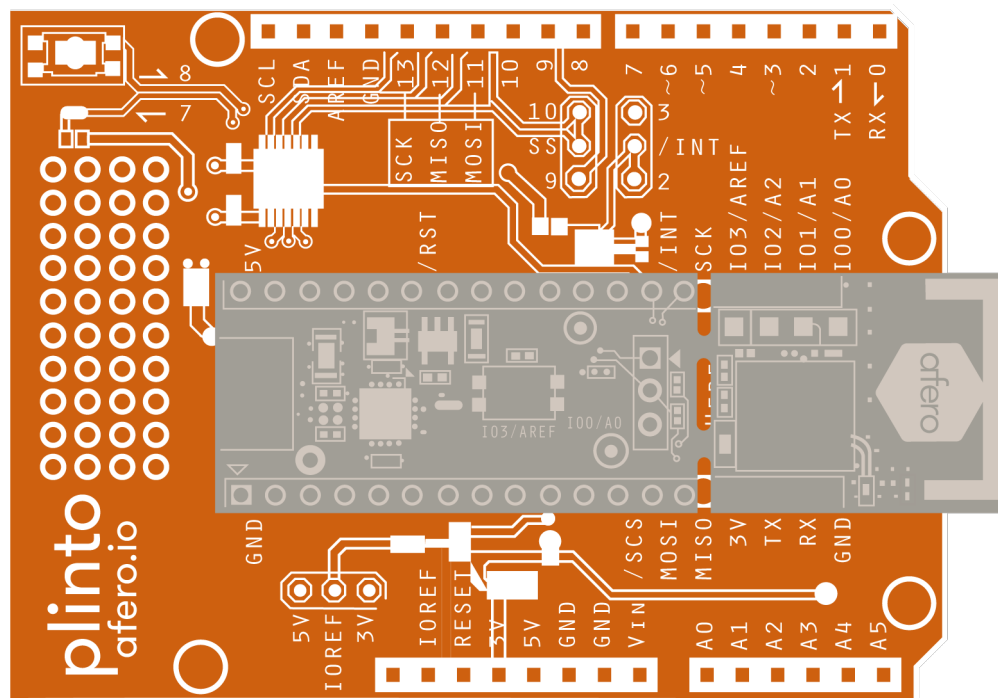

Modulo-Plinto connections



1.3 Specification

Model name	Modulo
Model number	AFERO-DB-01
Description	Afero secure radio module development kit
Bluetooth	Bluetooth® Smart wireless technology (4.1)
Bluetooth radio frequency	2.4 GHz
Ports	Backup battery connection
Buttons	1 GPIO input (configurable)
LED indicators	1 GPIO output (configurable)
Security type	256-bit ECC (Afero security)
Dimensions	2.35"W x .7"H x 0.175"D
Unit weight	5g
Power	5V, 100mA max
Certifications	FCC, IC
Operating temperature	0 to 40° C
Storage temperature	-20 to 60° C
Operating humidity	10 to 80% non-condensing
Storage humidity	5 to 90% non-condensing

1.4 Block Diagram

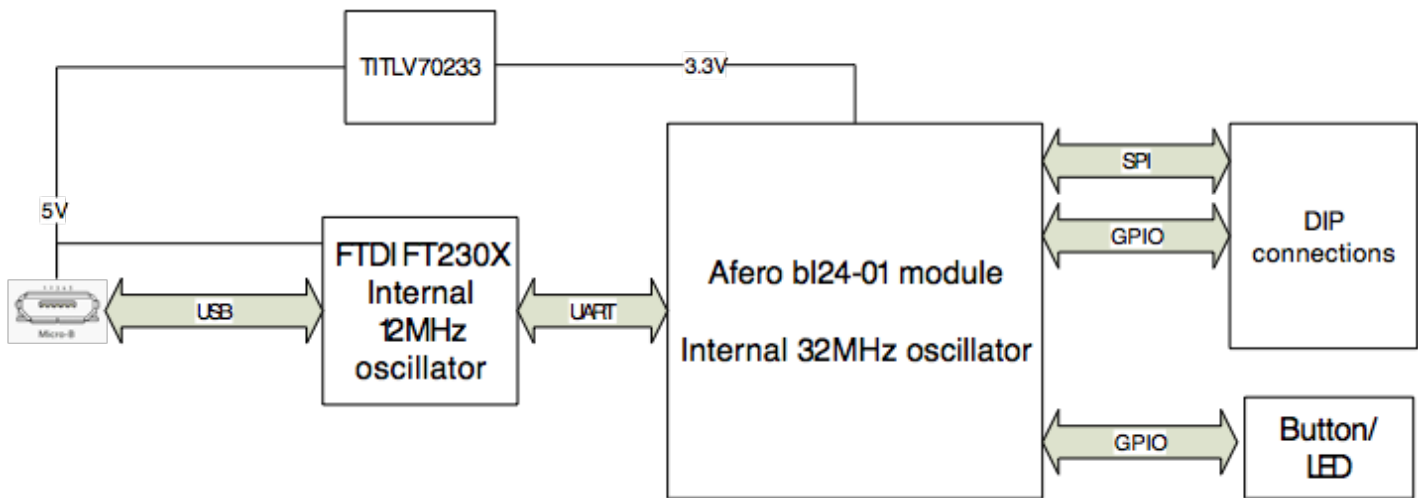

1.5 Acronyms

AIO	Analog Input / Output
GAP	Generic Access Profile
GATT	Generic ATtribute protocol
HID	Human Interface Device
L2CAP	Logical Link Control and Adaptation Protocol
PIO	Programmable Input / Output
PWM	Pulse Width Modulation
SPI	Serial Peripheral Interface
UART	Universal Asynchronous Receiver Transmitter

2

2.1 Pin Configuration

2.1.1 Pinout Diagram Top View

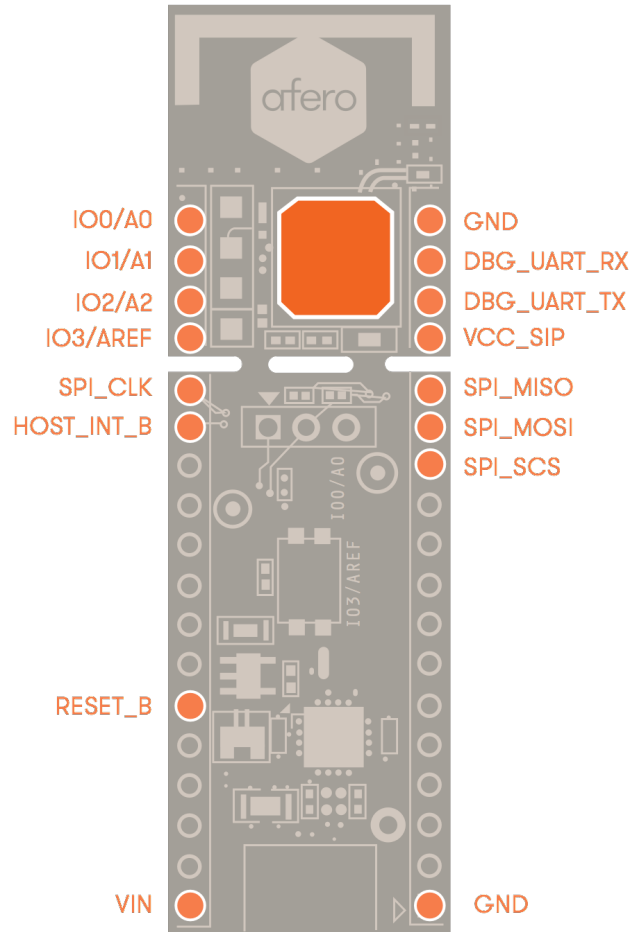



2.1.2 Pin descriptions

Pin Name	I/O	Description
GND	I/O	Ground
VCC	I/O	Module power (3.3V)
VIN	I	Power input from Teensy/Plinto (5V)
RESET_B	I	System reset (active low)
HOST_INT_B	O, open-drain	GPIO; host interrupt
IO0/A0	I/O	GPIO; ADC input 4 (Used for Modulo LED)
IO1/A1	I/O	GPIO; ADC input 2
IO2/A2	I/O	GPIO; ADC input 3
IO3/AREF	I/O	GPIO; ADC reference voltage (Used for Modulo button)
SPI_MISO	O	GPIO; SPI master input/slave output
SPI_SCS	I	GPIO; SPI slave select
SPI_SCLK	I	GPIO; SPI clock
SPI_MOSI	I	GPIO; SPI master output/slave input
DBG_UART_RX	I	Debugging/Factory UART RX
DBG_UART_TX	O	Debugging/Factory UART TX

3 DC Electrical Specification

3.1 Typical Power Consumption

	Current	Unit
TX Active (peak current)	15.5	mA
RX Active (peak current)	14.5	mA

3.2 GPIO Specification

A total of four lines of programmable bidirectional I/O are provided. Three of the GPIO lines can be configured to analog ADC or comparator inputs, and one (IO3/AREF) can be configured as an external analog reference.

3.2.1 Digital I/O Characteristics

Input Voltage Levels	Min.	Typ.	Max.	Unit
V _{IH} input logic level high	0.7 × VCC**	-	VCC**	V
V _{IL} input logic level low	V _{ss}	-	0.3 × VCC**	V
V _{OH} output logic level high (std. drive, 0.5 mA)	VCC**-0.3	-	VCC**	V
V _{OH} output logic level high (high drive, 5 mA)*	VCC**-0.3	-	VCC**	V
V _{OL} output logic level low (std. drive, 0.5 mA)	V _{ss} **	-	0.3	V
V _{OL} output logic level low (high drive, 5 mA)	V _{ss} **	-	0.3	V
R _{PU} Pull-up resistance	11	13	16	
R _{PD} Pull-down resistance	11	13	16	

* Maximum number of pins with 5mA high driver is 3.

* VCC is 3.3V; Vss is 0V



3.3 SPI Interface

The SPI interface operates in slave mode, at up to 1MHz.

3.3.1 SPI Slave Specification

3.3.1.1 Slave Characteristics

Parameters	Description	Min.	Typ.	Max.	Unit
ISPIS125K	Run current for SPI slave at 125 kbps*		180		μA
ISPIS2M	Run current for SPI slave at 2Mbps*		183		μA
fSPIS	Bit rates for SPIS	0.125		1	Mbps

* CSN asserted.

3.3.1.2 SPI Slave Timing Diagram, One Byte Transmission, SPI Mode 0

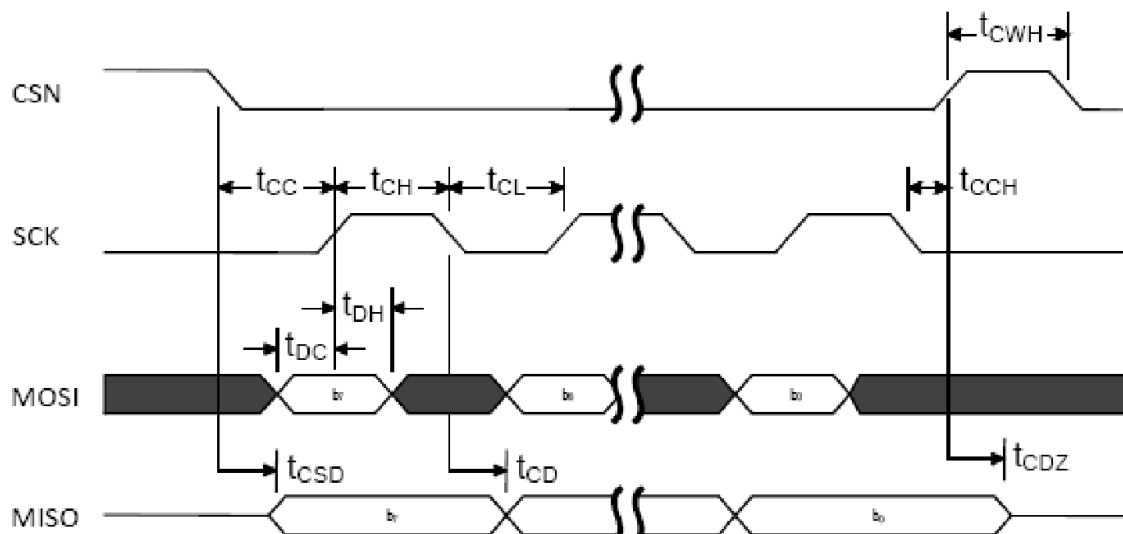

3.3.1.3 SPI Slave Timing Parameters

Parameters	Description	Note	Min.	Typ.	Max.	Unit
t _{DC}	Data to SCK setup		10			ns
t _{DH}	SCK to Data hold		10			ns
t _{CSD}	CSN to Data valid	Low power mode			7100	ns
		Constant latency mode			2100	ns
t _{CD}	SCK to Data valid	C _{LOAD} = 10pF			97**	ns
t _{CL}	SCK Low time		40			ns
t _{CH}	SCK High time		40			ns
t _{CC}	CSN to SCK setup	Low power mode	7000			ns
		Constant latency mode	2000			ns
t _{CCH}	Last SCK edge to CSN Hold		2000			ns
t _{CWH}	CSN Inactive time		300			ns
t _{CDZ}	CSN to Output High Z				40	ns
f _{SCK}	SCK frequency		0.125		1	MHz
t _R ,t _F	SCK Rise and Fall time				100	ns

** Increases/decreases with 1.2 ns/pF load.



3.4 UART Interface

The UART interface offers fast, full-duplex, asynchronous serial communication support in hardware up to 115.2Kbps. Parity checking is supported. It is connected to an FTDI FT230X UART-to-USB conversion IC.

3.4.1 UART Interface Parameters

Parameters	Description	Min.	Typ.	Max.	Unit
$I_{UART115k}$	Run current at 115200 bps	-	220-	-	μA
$I_{UART1k2}$	Run current at 1200 bps	-	210	-	μA
f_{UART}	Baud rate for UART	1.2	-	1000	kbps



3.5 ADC/Comparator Interface

The module supports one comparator input on pins IO0-2 and/or up to 3 A/D inputs on IO0-2. There is an optional external reference voltage on IO3/AVREF, or an internal voltage reference of 1-8 8ths of VCC can be used.

3.5.1 Auxiliary ADC Characteristics

Parameters	Description	Min.	Typ.	Max.	Unit
DNL _{10b}	Differential non-linearity (10bit mode)		< 1		LSB
INL _{10b}	Integral non-linearity (10 bit mode)		2		LSB
V _{os}	Offset error.	-2		+2	%
e _{G*}	Gain error.	-2		+2	%
V _{REF_VBG}	Internal Band Gap reference voltage (VBG).				
V _{REF_VBG_ERR}	Internal Band Gap reference voltage error.				
V _{REF_VBG_DRIFT}	Internal Band Gap reference voltage drift.	-200		+200	ppm/ °C
V _{REF_EXT}	External reference voltage (AREF0/1).	0.83	1.2	1.3	V
V _{REF_VDD_LIM}	Limited supply voltage range for ADC using VCC with prescaler as the reference. CONFIG.REFSEL = SupplyOneHalfPrescaling	1.7		2.6	V
	CONFIG.REFSEL = SupplyOneThirdPrescaling	2.5		3.6	V
t _{ADC10b}	Time required to convert a single sample in 10 bit mode.		68		μs
t _{ADC9b}	Time required to convert a single sample in 9 bit mode.		36		μs
t _{ADC8b}	Time required to convert a single sample in 8 bit mode.		20		μs
I _{ADC}	Current drawn by ADC during conversion.		260		μA
ADC_ERR_1V8	Absolute error when used for battery measurement at 1.8 V, 2.2 V, 2.6 V, 3.0 V, and 3.4 V		3		LSB
ADC_ERR_2V2			2		LSB
ADC_ERR_2V6			1		LSB
ADC_ERR_3V0			1		LSB
ADC_ERR_3V4			1		LSB



* Source impedance less than 5 k Ω .

** Internal reference, input from VCC/3, 10 bit mode. VCC is 3.3V

4 Environmental Specification

4.1 Absolute Maximum Rating

Description	Min	Max	Unit
Storage temperature	-40	85	°C
Operating temperature	-20	75	°C
VCC	-0.3	+3.9	V
VIO	-0.3	VCC+0.3	V

4.2 Recommended Operating Condition

Parameter	Min	Max	Unit
Operating Temperature Range	-20	75	°C
VCC	2.1	3.6	V

5 Regulatory information



Warning: Changes or modifications to this device not expressly approved by Afero could void the user's authority to operate the equipment.

5.1 FCC

NOTE: This equipment has been tested and found to comply with the limits for a Class A digital device, pursuant to part 15 of the FCC rules. These limits are designed to provide reasonable protection against harmful interference when the equipment is operated in a commercial environment. This equipment generates, uses, and can radiate radio frequency energy and, if not installed and used in accordance with the instruction manual, may cause harmful interference to radio communications. Operation of this equipment in a residential area is likely to cause harmful interference in which case the user will be required to correct the interference at his own expense.

This equipment complies with FCC radiation exposure limits set forth for an uncontrolled environment. This equipment should be installed and operated with minimum distance 20cm between the radiator and your body. This transmitter must not be co-located or operating in conjunction with any other antenna or transmitter.

Model: AFERO-DB-01

FCC ID: 2AGLL-AFERO-DB-01

IC: 20929-AFERODB01

This device complies with Part 15 of the FCC rules. Operation is subject to the following two conditions. (1) This device may not cause harmful interference, and (2) this device must accept any interference received, including interference that may cause undesired operation.

5.2 Industry Canada

This device complies with Industry Canada license-exempt RSS standard(s). Operation is subject to the following two conditions: (1) this device may not cause interference, and (2) this device must accept any interference, including interference that may cause undesired operation of the device.

Le présent appareil est conforme aux CNR d'Industrie Canada applicables aux appareils radio exempts de licence. L'exploitation est autorisée aux deux conditions suivantes: (1) l'appareil ne doit pas produire de brouillage, et (2) l'utilisateur de l'appareil doit accepter tout brouillage radioélectrique subi, même si le brouillage est susceptible d'en compromettre le fonctionnement.



Cet équipement est conforme aux limites d'exposition aux radiations dans un environnement non contrôlé. Cet équipement doit être installé et utilisé à distance minimum de 20 cm entre le radiateur et votre corps. Cet émetteur ne doit pas être co-localisées ou opérant en conjonction avec tout autre antenne ou transmetteur.

5.3 FCC Labeling Requirements

The modulo AFERO-DB-01 is labeled with its own FCC identification number. If the FCC identification number is not visible when the module is installed inside another device, then the outside of the device into which the module is installed must also display a label referring to the enclosed module. This exterior label can use wording such as the following: "Contains Transmitter Module FCC ID: 2AGLL-AFERO-DB-01" or "Contains FCC ID: FCC ID: 2AGLL-AFERO-DB-01." Any similar wording that expresses the same meaning may be used.

5.4 IC Labeling Requirements

The modulo AFERO-DB-01 is labeled with its own IC identification number. When installed in a host device, the host device and all the separately certified modules it contains jointly meet the RF exposure compliance requirements of RSS-102, if applicable.

The host device shall be properly labeled to identify the modules within the host device. The Industry Canada certification label of a module shall be clearly visible at all times when installed in the host device; otherwise, the host device must be labeled to display the Industry Canada certification number for the module, preceded by the words "Contains transmitter module", or the word "Contains", or similar wording expressing the same meaning, as follows:
Contains transmitter module IC: 20929-AFERODB01 where IC: 20929-AFERODB01 is the module's certification number. The applicant for equipment certification of the module shall provide with each unit of the module either a label such as described above, or an explanation and instructions to the user as to the host device labelling requirements.