

FCC Test Report

Part 15 subpart C

Client Information:

Applicant: Dongguan kotion Electronic Tech Co., LTD.
Applicant add.: Building No.35 Sanjiang Industrial Park, Hengli Town, Dongguan City, Guangdong, China

Product Information:

EUT Name: Bluetooth headset
B3506,B3505,B3507,B3508,B3509,B3510,B3511,B3512,B3513,B3515,B3516,B3517,B3518,B3519,B3520,Q1,Q2,Q3,Q4,Q5,Q6,Q7,Q8,Q9,Q10,
Model No.: 6,Rockerz 510
Brand Name: KOTION EACH
FCC ID: 2AGL8B3506

Standards: FCC PART 15 Subpart C: 2016 section 15.247

Test procedure used: ANSI C63.10-2013

Prepared By:

BEI FAN ELECTRONIC TECHNOLOGY CO.,LTD.

Add. : 267# On the Second Floor Twelve-story Building 8# Guantai Road Nancheng Dongguan

Date of Receipt: Jan. 01, 2017

Date of Test: Jan. 01~07, 2017

Date of Issue: Jan. 08, 2017

Test Result: Pass

This device described above has been tested by BEI FAN ELECTRONIC TECHNOLOGY CO.,LTD., and the test results show that the equipment under test (EUT) is in compliance with the FCC requirements. And it is applicable only to the tested sample identified in the report.

*This test report must not be used by the client to claim product endorsement by any agency of the U.S. government.

Reviewed by: Jane Lv

Approved by: Sam Chen

1 Contents

| | Page |
|----------------------------------------------------------|-----------|
| COVER PAGE | |
| 1 CONTENTS | 2 |
| 2 TEST SUMMARY | 4 |
| 2.1 COMPLIANCE WITH FCC PART 15 SUBPART C | 4 |
| 2.2 MEASUREMENT UNCERTAINTY | 5 |
| 2.3 TEST LOCATION | 5 |
| 3 GENERAL INFORMATION | 6 |
| 3.1 GENERAL DESCRIPTION OF EUT | 6 |
| 3.2 DESCRIPTION OF TEST CONDITIONS | 8 |
| 3.3 TEST PERIPHERAL LIST | 9 |
| 3.4 EUT PERIPHERAL LIST | 9 |
| 4 EQUIPMENTS LIST FOR ALL TEST ITEMS | 10 |
| 5 TEST RESULT | 11 |
| 5.1 ANTENNA REQUIREMENT | 11 |
| 5.1.1 Standard requirement | 11 |
| 5.1.2 EUT Antenna | 11 |
| 5.2 CONDUCTION EMISSIONS MEASUREMENT | 12 |
| 5.2.1 Applied procedures / Limit | 12 |
| 5.2.2 Test procedure | 12 |
| 5.2.3 Test setup | 12 |
| 5.2.4 Test results | 13 |
| 5.3 RADIATED EMISSIONS MEASUREMENT | 15 |
| 5.3.1 Applied procedures / Limit | 15 |
| 5.3.2 Test setup | 15 |
| 5.3.3 Test procedure | 17 |
| 5.3.4 Test Result | 18 |
| 5.3.5 TEST RESULTS (Restricted Bands Requirements) | 26 |
| 5.4 BANDWIDTH TEST | 27 |
| 5.4.1 Applied procedures / Limit | 27 |
| 5.4.2 Test procedure | 27 |
| 5.4.3 Deviation from standard | 27 |
| 5.4.4 Test setup | 27 |
| 5.4.5 Test results | 28 |
| 5.5 CARRIER FREQUENCIES SEPARATED | 34 |
| 5.5.1 Applied procedures / Limit | 34 |
| 5.5.2 Test procedure | 34 |
| 5.5.3 Deviation from standard | 34 |
| 5.5.4 Test setup | 34 |
| 5.5.5 Test results | 35 |

| | | |
|----------|-----------------------------------------------------------------|-----------|
| 5.6 | HOPPING CHANNEL NUMBER..... | 39 |
| 5.6.1 | Applied procedures / Limit | 39 |
| 5.6.2 | Test procedure..... | 39 |
| 5.6.3 | Deviation from standard..... | 39 |
| 5.6.4 | Test setup | 39 |
| 5.6.5 | Test result | 40 |
| 5.7 | DWELL TIME..... | 42 |
| 5.7.1 | Applied procedures / Limit | 42 |
| 5.7.2 | Test procedure..... | 42 |
| 5.7.3 | Deviation from standard..... | 42 |
| 5.7.4 | Test setup | 42 |
| 5.7.5 | Test result | 43 |
| 5.8 | MAXIMUM PEAK OUTPUT POWER..... | 47 |
| 5.8.1 | Applied procedures / Limit | 47 |
| 5.8.2 | Test procedure..... | 47 |
| 5.8.3 | Deviation from standard..... | 47 |
| 5.8.4 | Test setup | 47 |
| 5.8.5 | Test results | 48 |
| 5.9 | BAND EDGE | 54 |
| 5.9.1 | Applied procedures / Limit | 54 |
| 5.9.2 | Test procedure..... | 54 |
| 5.9.3 | Deviation from standard..... | 54 |
| 5.9.4 | Test setup | 54 |
| 5.9.5 | Test results | 55 |
| 5.10 | CONDUCTED SPURIOUS EMISSIONS | 59 |
| 5.10.1 | Applied procedures / Limit | 59 |
| 5.10.2 | Test procedure..... | 59 |
| 5.10.3 | Deviation from standard..... | 59 |
| 5.10.4 | Test setup | 59 |
| 5.10.5 | Test results | 60 |
| 6 | PHOTOGRAPHS..... | 72 |
| 6.1 | RADIATED SPURIOUS EMISSION TEST SETUP | 72 |
| 6.2 | CONDUCTED EMISSION TEST SETUP..... | 73 |
| 7 | APPENDIX-PHOTOGRAPHS OF EUT CONSTRUCTIONAL DETAILS | 74 |

2 Test Summary

2.1 Compliance with FCC Part 15 subpart C

| Test | Test Requirement | Standard Paragraph | Result |
|-------------------------------|--------------------|----------------------------|-------------|
| Antenna Requirement | FCC Part 15 C:2016 | Section 15.247(c) | PASS |
| Conduction Emissions | FCC Part 15 C:2016 | Section 15.207(a) | PASS |
| Radiated Emissions | FCC Part 15 C:2016 | Section 15.247(d) | PASS |
| Carrier Frequencies Separated | FCC Part 15 C:2016 | Section 15.247(a)(1) | PASS |
| Hopping Channel Number | FCC Part 15 C:2016 | Section 15.247(a)(1) (iii) | PASS |
| Dwell Time | FCC Part 15 C:2016 | Section 15.247(a)(1) (iii) | PASS |
| Maximum Peak Output Power | FCC Part 15 C:2016 | Section 15.247(b) | PASS |
| Band edge | FCC Part 15 C:2016 | Section 15.247(d) | PASS |
| Conducted Spurious Emissions | FCC Part 15 C:2016 | Section 15.247(d) | PASS |

2.2 Measurement Uncertainty

All measurements involve certain levels of uncertainties, The following measurements uncertainty Levels have estimated based on ANSI C63.10:2013, the maximum value of the uncertainty as below

| No. | Item | Uncertainty |
|------------|-------------------------|--------------------|
| 1 | Conducted Emission Test | 1.20dB |
| 2 | Radiated Emission Test | 3.30dB |

2.3 Test Location

All tests were performed at:

Dongguan Yaxu (AiT) Technology Limited
No.22, Jinqianling Third Street, Jitigang, Huangjiang,Dongguan, Guangdong, China
Tel.: +86.769.82020499 Fax.: +86.769.82020495

The FCC Registration No. of Dongguan Yaxu (AiT) Technology Limited is 248337.

3 General Information

3.1 General Description of EUT

| | |
|------------------------|-----------------------------------------------------------------------------------------------------------------------------------------------------------------------------------------------------------------------------------------------------------------------------------------------------|
| Manufacturer: | Dongguan kotion Electronic Tech Co., LTD. |
| Manufacturer Address: | Building No.35 Sanjiang Industrial Park, Hengli Town, Dongguan City, Guangdong, China |
| EUT Name: | Bluetooth headset |
| Model No: | B3506 |
| Derivative model No.: | B3505,B3507,B3508,B3509,B3510,B3511,B3512,B3513,B3515,B3516,B3517, B3518,B3519,B3520,Q1,Q2,Q3,Q4,Q5,Q6,Q7,Q8,Q9,Q10, Rockerz 510 |
| Brand Name: | KOTION EACH |
| Operation frequency: | 2402 MHz to 2480 MHz |
| NUMBER OF CHANNEL: | 79 |
| Modulation Technology: | GFSK, $\pi/4$ -DQPSK, 8DPSK(1/2/3Mbps) |
| Bluetooth version: | Bluetooth 4.1 single mode (classic rate & EDR) (Because of firmware limitation, for the Bluetooth function, this device only supports the classic rate & EDR mode without the BLE mode.) |
| H/W No.: | V 1.4 |
| S/W No.: | V 1.1 |
| Antenna Type: | Integral Antenna |
| Antenna Gain: | Maximum 0 dBi |
| Power Supply Range: | DC 3.7V from battery, MICRO USB 5V 1A |
| Power Supply: | DC 3.7V from battery, MICRO USB 5V 1A |
| Power Cord: | N/A |
| Output power (max) : | 1Mbps: -0.3dBm |
| | 3Mbps: 0.01dBm |
| Model description: | According to the declaration from the applicant, the electrical circuit design, layout, components used and internal wiring were identical for all models, with only difference being the model name & shell color & plastic shell shape. Therefore only one model B3506 was tested in this report. |
| Note: | |
| | 1. For a more detailed features description, please refer to the manufacturer's specifications or the User's Manual. |

| Description of Channel: | | | | | |
|-------------------------|-----------------|---------|-----------------|---------|-----------------|
| Channel | Frequency (MHz) | Channel | Frequency (MHz) | Channel | Frequency (MHz) |
| 00 | 2402 | 27 | 2429 | 54 | 2456 |
| 01 | 2403 | 28 | 2430 | 55 | 2457 |
| 02 | 2404 | 29 | 2431 | 56 | 2458 |
| 03 | 2405 | 30 | 2432 | 57 | 2459 |
| 04 | 2406 | 31 | 2433 | 58 | 2460 |
| 05 | 2407 | 32 | 2434 | 59 | 2461 |
| 06 | 2408 | 33 | 2435 | 60 | 2462 |
| 07 | 2409 | 34 | 2436 | 61 | 2463 |
| 08 | 2410 | 35 | 2437 | 62 | 2464 |
| 09 | 2411 | 36 | 2438 | 63 | 2465 |
| 10 | 2412 | 37 | 2439 | 64 | 2466 |
| 11 | 2413 | 38 | 2440 | 65 | 2467 |
| 12 | 2414 | 39 | 2441 | 66 | 2468 |
| 13 | 2415 | 40 | 2442 | 67 | 2469 |
| 14 | 2416 | 41 | 2443 | 68 | 2470 |
| 15 | 2417 | 42 | 2444 | 69 | 2471 |
| 16 | 2418 | 43 | 2445 | 70 | 2472 |
| 17 | 2419 | 44 | 2446 | 71 | 2473 |
| 18 | 2420 | 45 | 2447 | 72 | 2474 |
| 19 | 2421 | 46 | 2448 | 73 | 2475 |
| 20 | 2422 | 47 | 2449 | 74 | 2476 |
| 21 | 2423 | 48 | 2450 | 75 | 2477 |
| 22 | 2424 | 49 | 2451 | 76 | 2478 |
| 23 | 2425 | 50 | 2452 | 77 | 2479 |
| 24 | 2426 | 51 | 2453 | 78 | 2480 |
| 25 | 2427 | 52 | 2454 | | |
| 26 | 2428 | 53 | 2455 | | |

3.2 Description of Test conditions

(1) EUT was tested in normal configuration (Please See following Block diagram)

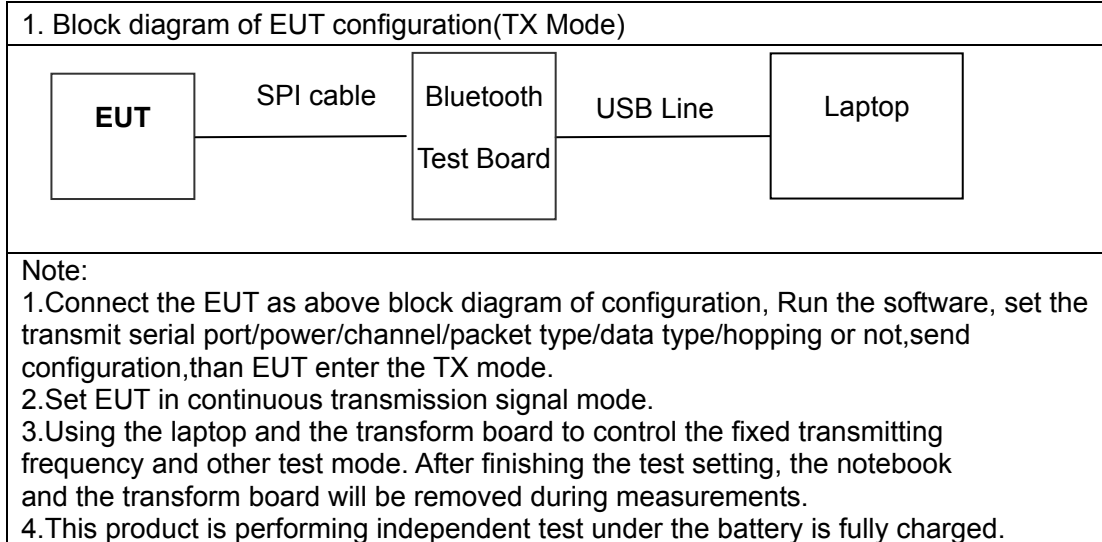

(2) E.U.T. test conditions:

15.31(e): For intentional radiators, measurements of the variation of the input power or the radiated signal level of the fundamental frequency component of the emission, as appropriate, shall be performed with the supply voltage varied between 85% and 115% of the nominal rated supply voltage. For battery operated equipment, the equipment tests shall be performed using a new battery.

(3) Test frequencies:

According to the 15.31(m) Measurements on intentional radiators or receivers, other than TV broadcast receivers, shall be performed and. If required reported for each band in which the device can be operated with the device operating at the number of frequencies in each band specified in the following table:

| Frequency range over which device operates | Number of frequencies | Location in the range of operation |
|--------------------------------------------|-----------------------|---------------------------------------------|
| 1 MHz or less | 1 | Middle |
| 1 to 10 MHz | 2 | 1 near top and 1 near bottom |
| More than 10 MHz | 3 | 1 near top, 1 near middle and 1 near bottom |

(4) Frequency range of radiated measurements:

According to the 15.33, the test range will be up to the tenth harmonic of the highest fundamental frequency.

(5) Pre-test the EUT in all transmitting mode at the lowest (2402 MHz), middle (2441 MHz) and highest (2480 MHz) channel with different data packet and conducted to determine the worst-case mode, only the worst-case results(1Mbps/3Mbps) are recorded in this report.

(6) The radiation measurements are performed in X, Y, Z axis positioning. And found the X axis positioning which it is worse case, only the test worst case mode is recorded in the report.

3.3 Test Peripheral List

| No. | Equipment | Manufacturer | EMC Compliance | Model No. | Serial No. | Power cord | signal cable |
|-----|----------------------|--------------|----------------|------------|------------|-----------------------------|--------------|
| 1 | Lap top | ASUS | N/A | X401A | X16-96072 | N/A | N/A |
| 2 | Adapter (laptop) | ASUS | N/A | EXA0703 YH | N/A | 1.8m/unshielded /detachable | N/A |
| 3 | Bluetooth Test Board | N/A | N/A | N/A | N/A | N/A | N/A |
| 4 | Adapter | SCO | N/A | SCO602B TA | N/A | 0.8m x 2 wires unshielded | N/A |

3.4 EUT Peripheral List

| No. | Equipment | Manufacturer | EMC Compliance | Model No. | Serial No. | Power cord | signal cable |
|-----|---------------|--------------|----------------|-----------|------------|--------------------------|-------------------------|
| 1 | USB cable | N/A | N/A | N/A | N/A | 0.63m x 2 wires screened | N/A |
| 2 | Line-in cable | N/A | N/A | N/A | N/A | N/A | 1.2m x 2 wires screened |

4 Equipments List for All Test Items

| No | Test Equipment | Manufacturer | Model No | Serial No | Cal. Date | Cal. Due Date |
|----|------------------------------------------------------------|-----------------|------------------|-------------|------------|---------------|
| 1 | Spectrum Analyzer | ADVANTEST | R3182 | 150900201 | 2016.06.29 | 2017.06.28 |
| 2 | EMI Measuring Receiver | Schaffner | SCR3501 | 235 | 2016.06.29 | 2017.06.28 |
| 3 | Low Noise Pre Amplifier | Tsj | MLA-10K01-B01-27 | 1205323 | 2016.06.29 | 2017.06.28 |
| 4 | Low Noise Pre Amplifier | Tsj | MLA-0120-A02-34 | 2648A04738 | 2016.06.29 | 2017.06.28 |
| 5 | TRILOG Super Broadband test Antenna | SCHWARZBECK | VULB9160 | 9160-3206 | 2016.06.29 | 2017.06.28 |
| 6 | Broadband Horn Antenna | SCHWARZBECK | BBHA9120D | 452 | 2016.06.29 | 2017.06.28 |
| 7 | SHF-EHF Horn Antenna | SCHWARZBECK | BBHA9170 | BBHA9170367 | 2016.06.29 | 2017.06.28 |
| 8 | 50Ω Coaxial Switch | Anritsu | MP59B | 6200264416 | 2016.06.29 | 2017.06.28 |
| 9 | EMI Test Receiver | R&S | ESCI | 100124 | 2016.06.29 | 2017.06.28 |
| 10 | LISN | Kyoritsu | KNW-242 | 8-837-4 | 2016.06.29 | 2017.06.28 |
| 11 | LISN | Kyoritsu | KNW-407 | 8-1789-3 | 2016.06.29 | 2017.06.28 |
| 12 | 50Ω Coaxial Switch | Anritsu | MP59B | 6200264417 | 2016.06.29 | 2017.06.28 |
| 13 | Loop Antenna | ARA | PLA-1030/B | 1029 | 2016.06.29 | 2017.06.28 |
| 14 | EMI Test Receiver | Rohde & Schwarz | ESIB26 | 100394 | 2016.06.29 | 2017.06.28 |
| 15 | Radiated Cable 1# (30MHz-1GHz) | FUJIKURA | 5D-2W | 01 | 2016.06.29 | 2017.06.28 |
| 16 | Radiated Cable 2# (1GHz -25GHz) | FUJIKURA | 10D2W | 02 | 2016.06.29 | 2017.06.28 |
| 17 | Conducted Cable 1#(9KHz-30MHz) | FUJIKURA | 1D-2W | 01 | 2016.06.29 | 2017.06.28 |
| 18 | SMA Antenna connector (Impedance:50OHM, cable loss:0.5dBm) | Dosin | Dosin-SMA | N/A | N/A | N/A |

Note: The temporary antenna connector is soldered on the PCB board in order to perform conducted tests and this temporary antenna connector is listed in the equipment list.

5 Test Result

5.1 Antenna Requirement

5.1.1 Standard requirement

15.203 requirement: For intentional device, according to 15.203: an intentional radiator shall be designed to ensure that no antenna other than that furnished by the responsible party shall be used with the device.

15.247(c) (1)(i) requirement: (i) Systems operating in the 2400-2483.5 MHz band that is used exclusively for fixed. Point-to-point operations may employ transmitting antennas with directional gain greater than 6dBi provided the maximum conducted output power of the intentional radiator is reduced by 1 dB for every 3 dB that the directional gain of the antenna exceeds 6dBi.

5.1.2 EUT Antenna

The antenna is Integral Antenna and no consideration of replacement. Antenna gain is Maximum 0 dBi from 2.4GHz to 2.5GHz.

5.2 Conduction Emissions Measurement

5.2.1 Applied procedures / Limit

| Frequency of Emission (MHz) | Conducted Limit (dB μ V) | |
|-----------------------------|------------------------------|------------|
| | Quasi-peak | Average |
| 0.15-0.5 | 66 to 56 * | 56 to 46 * |
| 0.5-5 | 56 | 46 |
| 5-30 | 60 | 50 |

Note: Decreases with the logarithm of the frequency.

5.2.2 Test procedure

EUT was placed upon a wooden test table 0.8m above the horizontal metal reference plane and 0.4m from the vertical ground plane, and it was connected to an AMN. The closest distance between the boundary of the EUT and the surface of the AMN is 0.8m. All peripherals were connected to another AMN, and placed at a distance of 10cm from each other. A spectrum and receiver was connected to the RF output port of the AMN. Both average and quasi-peak value were detected.

5.2.3 Test setup

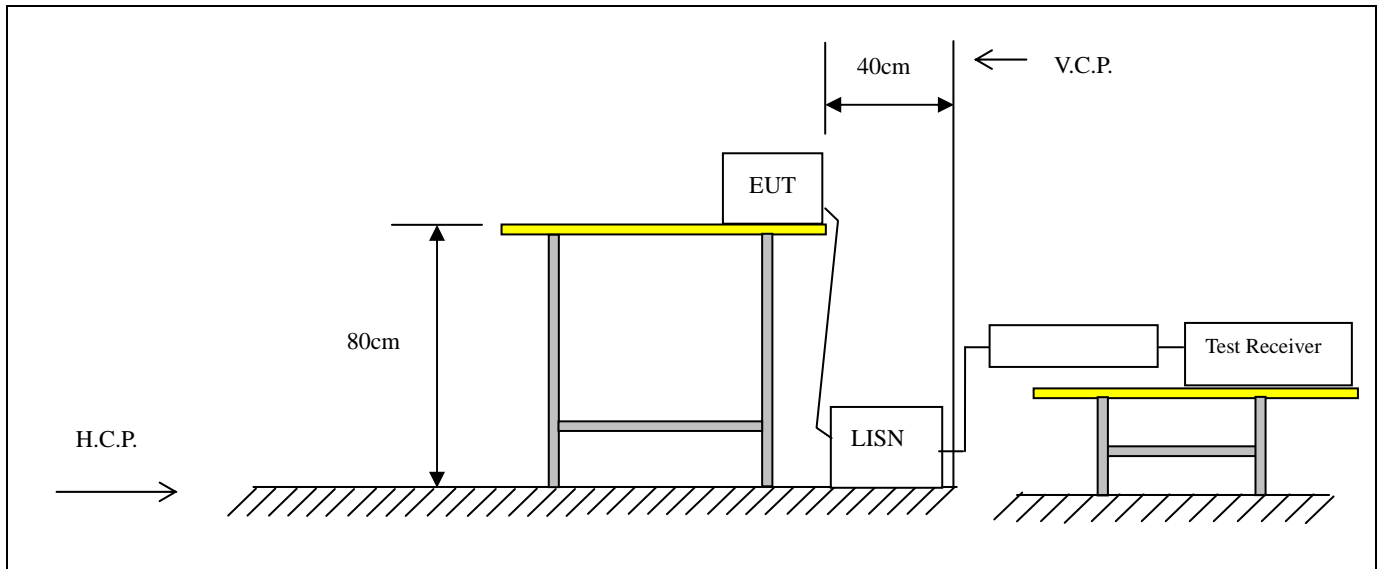

5.2.4 Test results

| | | | |
|-----------------------|----------------------------------------------|--------------------|------------|
| EUT: | Bluetooth headset | Model Name. : | B3506 |
| Temperature: | 26 °C | Relative Humidity: | 54% |
| Pressure: | 1010hPa | Test Date : | 2017-01-04 |
| Test Mode: | TX (1Mbps) CH00 (worst case) | Phase : | Line |
| Test Voltage : | DC 5V from adapter, AC 120V/60Hz for adapter | | |

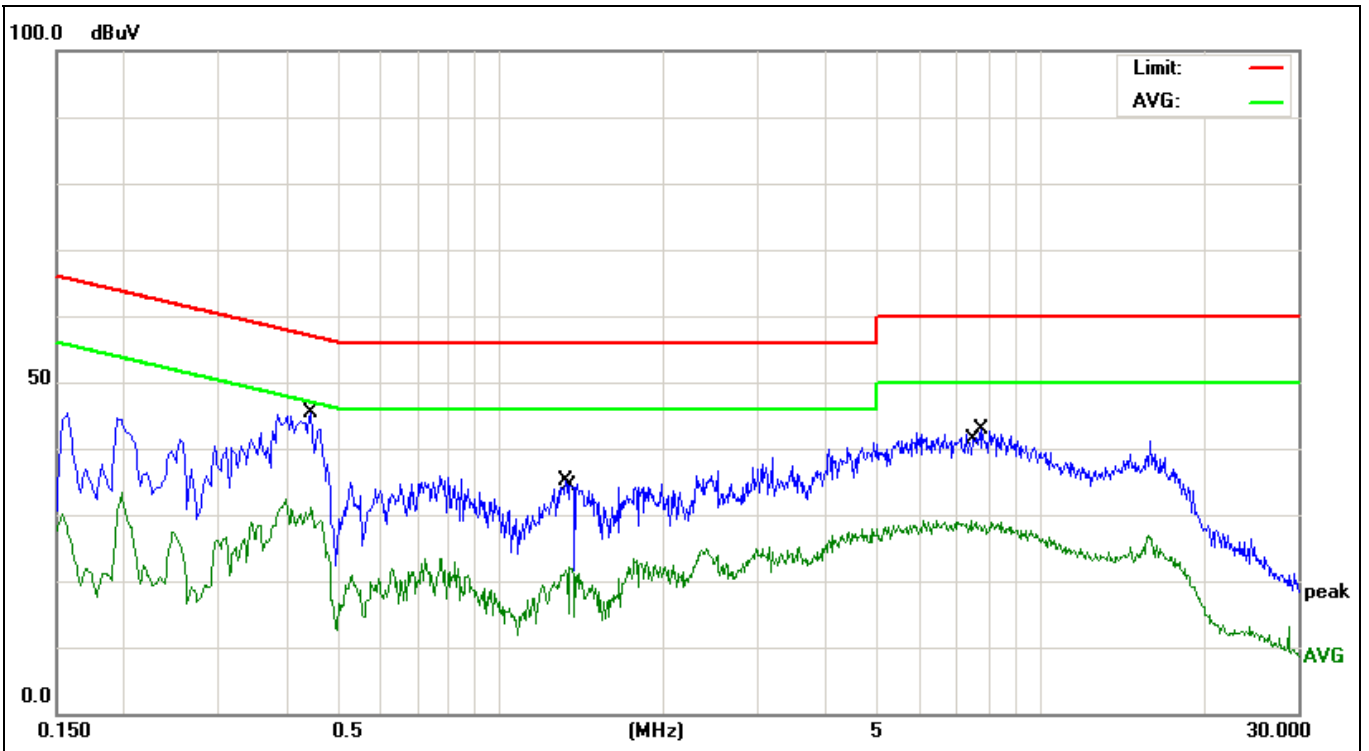

Remark: Factor = LISN factor + Cable Loss + Pulse limiter factor.

| No. | Mk. | Freq. | Reading Level | Correct Factor | Measurement | Limit | Over | Detector |
|-----|-----|--------|---------------|----------------|-------------|-------|--------|----------|
| | | MHz | dBuV | dB | dBuV | dBuV | dB | |
| 1 | * | 0.4460 | 35.33 | 10.07 | 45.40 | 56.95 | -11.55 | QP |
| 2 | | 0.4460 | 20.97 | 10.07 | 31.04 | 46.95 | -15.91 | AVG |
| 3 | | 1.3180 | 25.17 | 9.96 | 35.13 | 56.00 | -20.87 | QP |
| 4 | | 1.3420 | 12.24 | 9.96 | 22.20 | 46.00 | -23.80 | AVG |
| 5 | | 7.4460 | 18.91 | 10.18 | 29.09 | 50.00 | -20.91 | AVG |
| 6 | | 7.7700 | 32.70 | 10.19 | 42.89 | 60.00 | -17.11 | QP |

| | | | |
|-----------------------|----------------------------------------------|--------------------|------------|
| EUT: | Bluetooth headset | Model Name. : | B3506 |
| Temperature: | 26 °C | Relative Humidity: | 54% |
| Pressure: | 1010hPa | Test Date : | 2017-01-04 |
| Test Mode: | TX (1Mbps) CH00 (worst case) | Phase : | Neutral |
| Test Voltage : | DC 5V from adapter, AC 120V/60Hz for adapter | | |

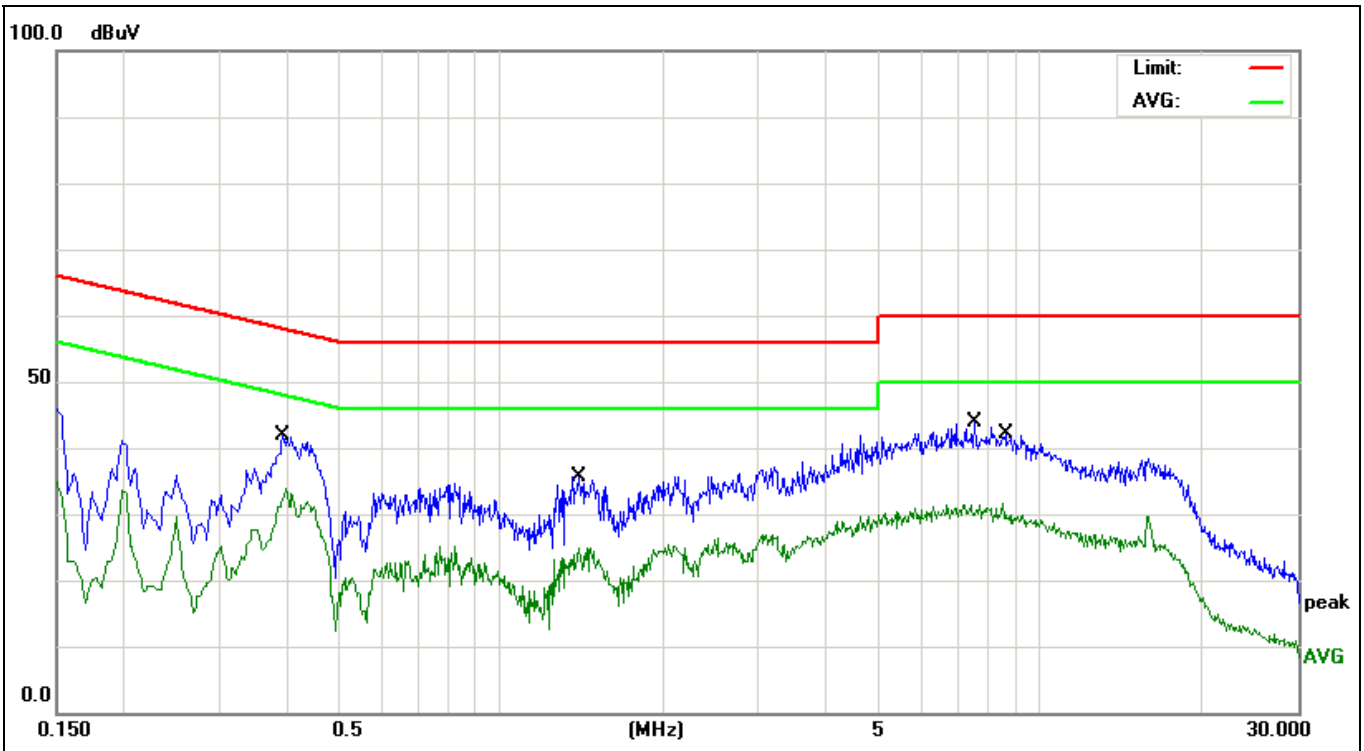

Remark: Factor = LISN factor + Cable Loss + Pulse limiter factor.

| No. | Mk. | Freq. MHz | Reading Level dBuV | Correct Factor dB | Measure- ment dBuV | Limit dBuV | Over dB | Detector |
|-----|-----|--------------|--------------------------|-------------------------|--------------------------|---------------|------------|----------|
| 1 | | 0.3940 | 31.64 | 10.13 | 41.77 | 57.98 | -16.21 | QP |
| 2 | * | 0.3980 | 23.70 | 10.13 | 33.83 | 47.89 | -14.06 | AVG |
| 3 | | 1.3900 | 15.02 | 9.96 | 24.98 | 46.00 | -21.02 | AVG |
| 4 | | 1.4020 | 25.71 | 9.96 | 35.67 | 56.00 | -20.33 | QP |
| 5 | | 7.5300 | 33.59 | 10.18 | 43.77 | 60.00 | -16.23 | QP |
| 6 | | 8.5020 | 21.53 | 10.20 | 31.73 | 50.00 | -18.27 | AVG |

5.3 Radiated Emissions Measurement

5.3.1 Applied procedures / Limit

15.247(d) In any 100 kHz bandwidth outside the frequency band in which the spread spectrum or digitally modulated intentional radiator is operating, the radio frequency power that is produced by the intentional radiator shall be at least 20 dB below that in the 100 kHz bandwidth within the band that contains the highest level of the desired power, based on either an RF conducted or a radiated measurement, provided the transmitter demonstrates compliance with the peak conducted power limits. If the transmitter complies with the conducted power limits based on the use of RMS averaging over a time interval, as permitted under paragraph (b)(3) of this section, the attenuation required under this paragraph shall be 30 dB instead of 20 dB. Attenuation below the general limits specified in Section 15.209(a) is not required. In addition, radiated emissions which fall in the restricted bands, as defined in Section 15.205(a), must also comply with the radiated emission limits specified in Section 15.209(a) (see Section 15.205(c)).

| Frequency of Emission (MHz) | Field Strength | | Measurement Distance (meters) |
|-----------------------------|-----------------|--------------------------|-------------------------------|
| | $\mu\text{V/m}$ | $\text{dB}\mu\text{V/m}$ | |
| 0.009-0.49 | 2400/F(kHz) | | 300 |
| 0.49-1.705 | 24000/F(kHz) | | 30 |
| 1.705-30 | 30 | | 30 |
| 30-88 | 100 | 40 | 3 |
| 88-216 | 150 | 43.5 | 3 |
| 216-960 | 200 | 46 | 3 |
| Above 960 | 500 | 54 | 3 |

5.3.2 Test setup

Test Configuration:

1) 9 kHz to 30 MHz emissions:

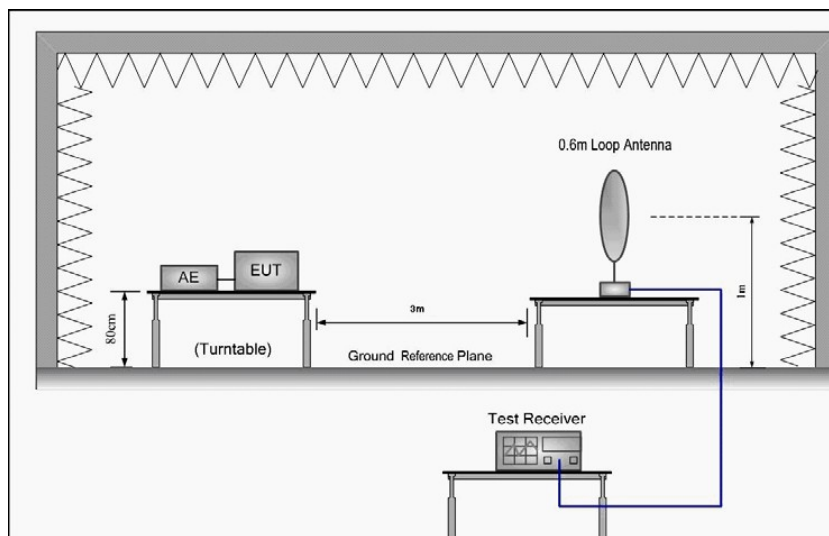

2) 30 MHz to 1 GHz emissions:

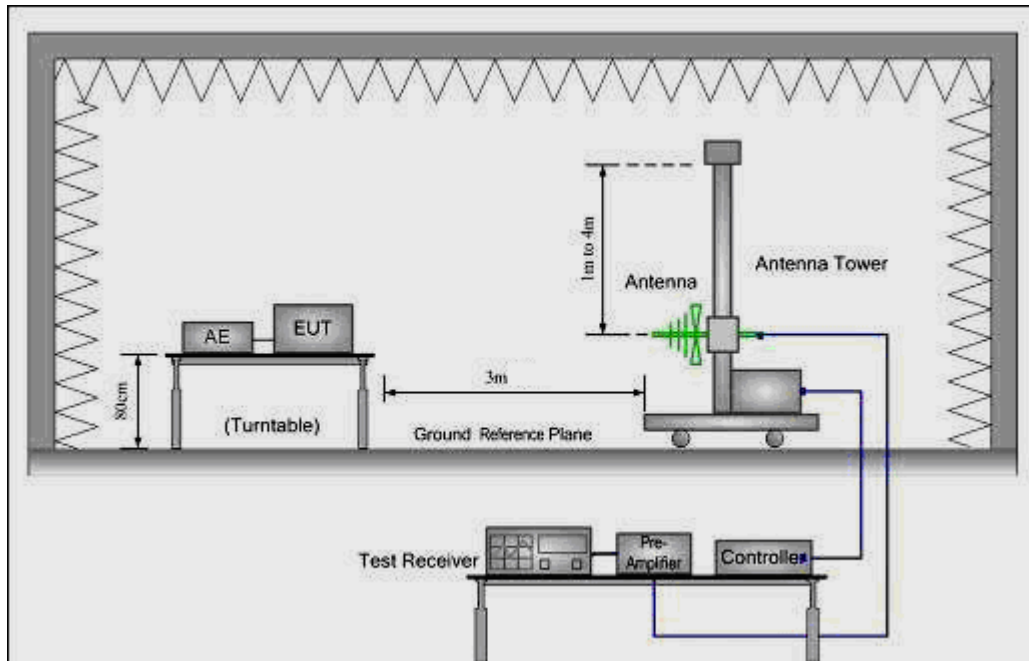

3) 1 GHz to 25 GHz emissions:

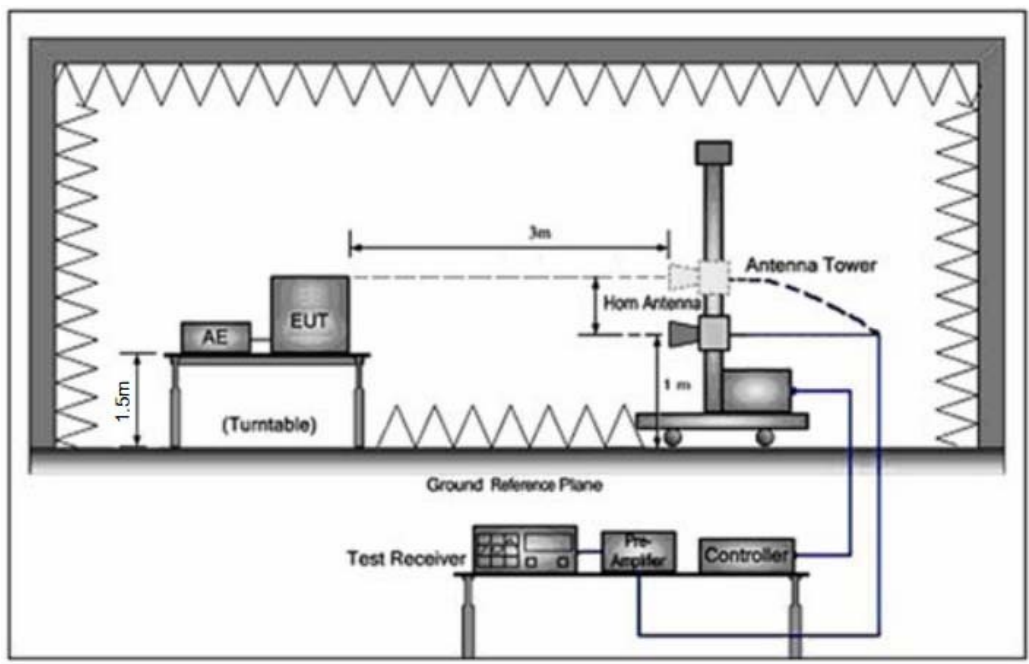

5.3.3 Test procedure

EUT was placed upon a wooden test table which was placed on the turn table and operating in the mode as mentioned above. For emissions testing at or below 1 GHz, the table height shall be 80 cm above the reference ground plane. For emission measurements above 1 GHz, the table height shall be 1.5 m. A receiving antenna was placed 3m away from the EUT. During testing, turn around the turn table and move the antenna from 1m to 4m to find the maximum field-strength reading. All peripherals were placed at a distance of 10cm between each other. Both horizontal and vertical antenna polarities were tested. The worst case emissions were reported.

For measurement at frequency above 1GHz

Place the measurement antenna away from each area of the EUT determined to be a source of emissions at the specified measurement distance, while keeping the measurement antenna aimed at the source of emissions at each frequency of significant emissions, with polarization oriented for maximum response. The measurement antenna may have to be higher or lower than the EUT, depending on the radiation pattern of the emission and staying aimed at the emission source for receiving the maximum signal. The final measurement antenna elevation shall be that which maximizes the emissions. The measurement antenna elevation for maximum emissions shall be restricted to a range of heights of from 1 m to 4 m above the ground or reference ground plane.

5.3.4 Test Result

Radiated Emissions Test Data Below 30MHz

| | | | |
|----------------------|----------------------------------------------------------|--------------------|----------------------|
| EUT: | Bluetooth headset | Model Name : | B3506 |
| Temperature: | 25 °C | Test Data | 2017-01-04 |
| Pressure: | 1005 hPa | Relative Humidity: | 60% |
| Test Mode : | TX | Test Voltage : | DC 3.7V from battery |
| Measurement Distance | 3 m | Frenqucy Range | 9KHz to 30MHz |
| RBW/VBW | 9KHz~150KHz/RB 200Hz for QP, 150KHz~30MHz/RB 9KHz for QP | | |

No emission found between lowest internal used/generated frequencies to 30MHz.

Radiated Emissions Test Data Below 1GHz

| | | | |
|----------------------|--------------------------------------------------------|--------------------|----------------------|
| EUT: | Bluetooth headset | Model Name : | B3506 |
| Temperature: | 25 °C | Test Data | 2017-01-04 |
| Pressure: | 1010 hPa | Relative Humidity: | 60% |
| Test Mode : | TX (1Mbps) CH00 (worst case) | Test Voltage : | DC 3.7V from battery |
| Measurement Distance | 3 m | Frenqucy Range | 30MHz to 1GHz |
| RBW/VBW | 100KHz / 300KHz for spectrum, RBW=120KHz for receiver. | | |

(a) Antenna polarization: Horizontal

| Frequency (MHz) | Reading Level (dBuV) | Correct Factor (dB) | Measure Level (dBuV/m) | Limit (dBuV/m) | Over (dB) | Detector Type |
|-----------------|----------------------|---------------------|------------------------|----------------|-----------|---------------|
| 39.9942 | 30.37 | -16.60 | 13.77 | 40.00 | -26.23 | QP |
| 97.4560 | 36.93 | -15.66 | 21.27 | 43.50 | -22.23 | QP |
| 124.1330 | 33.93 | -15.11 | 18.82 | 43.50 | -24.68 | QP |
| 301.4224 | 35.01 | -9.55 | 25.46 | 46.00 | -20.54 | QP |
| 601.4265 | 32.06 | -0.89 | 31.17 | 46.00 | -14.83 | QP |
| 952.0937 | 32.82 | 3.77 | 36.59 | 46.00 | -9.41 | QP |

(b) Antenna polarization: vertical

| Frequency (MHz) | Reading Level (dBuV) | Correct Factor (dB) | Measure Level (dBuV/m) | Limit (dBuV/m) | Over (dB) | Detector Type |
|-----------------|----------------------|---------------------|------------------------|----------------|-----------|---------------|
| 45.2166 | 30.20 | -14.47 | 15.73 | 40.00 | -24.27 | QP |
| 120.6991 | 31.21 | -14.94 | 16.27 | 43.50 | -27.23 | QP |
| 183.2005 | 31.34 | -11.34 | 20.00 | 43.50 | -23.50 | QP |
| 324.4561 | 37.65 | -8.75 | 28.90 | 46.00 | -17.10 | QP |
| 701.7610 | 31.26 | 0.32 | 31.58 | 46.00 | -14.42 | QP |
| 1000.000 0 | 30.63 | 5.10 | 35.73 | 54.00 | -18.27 | QP |

Note:

Measurement Level = Reading Level + Factor

Remark: Factor = Antenna Factor + Cable Loss–Pre-amplifier

Radiated Emissions Test Data Above 1GHz

| | | | |
|----------------------|---------------------------------------------------------------------------------------------------------------|--------------------|----------------------|
| EUT: | Bluetooth headset | Model Name : | B3506 |
| Temperature: | 25 °C | Test Data | 2017-01-04 |
| Pressure: | 1010 hPa | Relative Humidity: | 60% |
| Test Mode : | 1Mbps | Test Voltage : | DC 3.7V from battery |
| Measurement Distance | 3 m | Frenqucy Range | 1GHz to 25GHz |
| RBW/VBW | Spurious emission: 1MHz/3MHz for Peak, 1MHz/10Hz for Average. non-restricted band: 100KHz/300KHz for Peak. | | |

(a) Antenna polarization: Horizontal

| Frequency (MHz) | Reading Level (dBuV) | Correct Factor (dB) | Measure Level (dBuV/m) | Limit (dBuV/m) | Over (dB) | Detector Type |
|-----------------|----------------------|---------------------|------------------------|----------------|-----------|---------------|
| 4804.000 | 51.02 | 5.06 | 56.08 | 74.00 | -17.92 | peak |
| 4804.000 | 39.45 | 5.06 | 44.51 | 54.00 | -9.49 | AVG |
| 7206.000 | 44.37 | 7.03 | 51.40 | 74.00 | -22.60 | peak |
| 7206.000 | 32.58 | 7.03 | 39.61 | 54.00 | -14.39 | AVG |

(b) Antenna polarization: Vertical

| Frequency (MHz) | Reading Level (dBuV) | Correct Factor (dB) | Measure Level (dBuV/m) | Limit (dBuV/m) | Over (dB) | Detector Type |
|-----------------|----------------------|---------------------|------------------------|----------------|-----------|---------------|
| 4804.000 | 51.87 | 5.06 | 56.93 | 74.00 | -17.07 | peak |
| 4804.000 | 41.41 | 5.06 | 46.47 | 54.00 | -7.53 | AVG |
| 7206.000 | 45.15 | 7.03 | 52.18 | 74.00 | -21.82 | peak |
| 7206.000 | 33.56 | 7.03 | 40.59 | 54.00 | -13.41 | AVG |

Note:

8~25GHz at least have 20dB margin. No recording in the test report.

Measurement Level = Reading Level + Factor

Remark: Factor = Antenna Factor + Cable Loss–Pre-amplifier

Lowest channel: 2402 MHz

Data rate: 1Mbps

(a) Antenna polarization: Horizontal

| Frequency (MHz) | Reading Level (dBuV) | Correct Factor (dB) | Measure Level (dBuV/m) | Limit (dBuV/m) | Over (dB) | Detector Type |
|-----------------|----------------------|---------------------|------------------------|----------------|-----------|---------------|
| 4882.000 | 51.07 | 5.14 | 56.21 | 74.00 | -17.79 | peak |
| 4882.000 | 39.64 | 5.14 | 44.78 | 54.00 | -9.22 | AVG |
| 7323.000 | 43.89 | 7.54 | 51.43 | 74.00 | -22.57 | peak |
| 7323.000 | 33.62 | 7.54 | 41.16 | 54.00 | -12.84 | AVG |

(b) Antenna polarization: Vertical

| Frequency (MHz) | Reading Level (dBuV) | Correct Factor (dB) | Measure Level (dBuV/m) | Limit (dBuV/m) | Over (dB) | Detector Type |
|-----------------|----------------------|---------------------|------------------------|----------------|-----------|---------------|
| 4882.000 | 51.38 | 5.14 | 56.52 | 74.00 | -17.48 | peak |
| 4882.000 | 40.77 | 5.14 | 45.91 | 54.00 | -8.09 | AVG |
| 7323.000 | 44.42 | 7.54 | 51.96 | 74.00 | -22.04 | peak |
| 7323.000 | 34.70 | 7.54 | 42.24 | 54.00 | -11.76 | AVG |

Note:

8~25GHz at least have 20dB margin. No recording in the test report.

Measurement Level = Reading Level + Factor

Remark: Factor = Antenna Factor + Cable Loss–Pre-amplifier

Middle Channel: 2441 MHz

Data rate: 1Mbps

(a) Antenna polarization: Horizontal

| Frequency (MHz) | Reading Level (dBuV) | Correct Factor (dB) | Measure Level (dBuV/m) | Limit (dBuV/m) | Over (dB) | Detector Type |
|-----------------|----------------------|---------------------|------------------------|----------------|-----------|---------------|
| 4960.000 | 51.57 | 5.22 | 56.79 | 74.00 | -17.21 | peak |
| 4960.000 | 39.09 | 5.22 | 44.31 | 54.00 | -9.69 | AVG |
| 7440.000 | 42.95 | 8.06 | 51.01 | 74.00 | -22.99 | peak |
| 7440.000 | 32.37 | 8.06 | 40.43 | 54.00 | -13.57 | AVG |

(b) Antenna polarization: Vertical

| Frequency (MHz) | Reading Level (dBuV) | Correct Factor (dB) | Measure Level (dBuV/m) | Limit (dBuV/m) | Over (dB) | Detector Type |
|-----------------|----------------------|---------------------|------------------------|----------------|-----------|---------------|
| 4960.000 | 53.62 | 5.22 | 58.84 | 74.00 | -15.16 | peak |
| 4960.000 | 40.03 | 5.22 | 45.25 | 54.00 | -8.75 | AVG |
| 7440.000 | 45.29 | 8.06 | 53.35 | 74.00 | -20.65 | peak |
| 7440.000 | 34.58 | 8.06 | 42.64 | 54.00 | -11.36 | AVG |

Note:

8~25GHz at least have 20dB margin. No recording in the test report.

Measurement Level = Reading Level + Factor

Remark: Factor = Antenna Factor + Cable Loss–Pre-amplifier

Highest Channel: 2480 MHz

Data rate: 1Mbps

| | | | |
|----------------------|---------------------------------------------------------------------------------------------------------------|--------------------|----------------------|
| EUT: | Bluetooth headset | Model Name : | B3506 |
| Temperature: | 25 °C | Test Data | 2017-01-04 |
| Pressure: | 1010 hPa | Relative Humidity: | 60% |
| Test Mode : | 3Mbps | Test Voltage : | DC 3.7V from battery |
| Measurement Distance | 3 m | Frenqucy Range | 1GHz to 25GHz |
| RBW/VBW | Spurious emission: 1MHz/3MHz for Peak, 1MHz/10Hz for Average. non-restricted band: 100KHz/300KHz for Peak. | | |

(a) Antenna polarization: Horizontal

| Frequency (MHz) | Reading Level (dBuV) | Correct Factor (dB) | Measure Level (dBuV/m) | Limit (dBuV/m) | Over (dB) | Detector Type |
|-----------------|----------------------|---------------------|------------------------|----------------|-----------|---------------|
| 4804.000 | 50.83 | 5.06 | 55.89 | 74.00 | -18.11 | peak |
| 4804.000 | 39.10 | 5.06 | 44.16 | 54.00 | -9.84 | AVG |
| 7206.000 | 45.23 | 7.03 | 52.26 | 74.00 | -21.74 | peak |
| 7206.000 | 32.78 | 7.03 | 39.81 | 54.00 | -14.19 | AVG |

(b) Antenna polarization: Vertical

| Frequency (MHz) | Reading Level (dBuV) | Correct Factor (dB) | Measure Level (dBuV/m) | Limit (dBuV/m) | Over (dB) | Detector Type |
|-----------------|----------------------|---------------------|------------------------|----------------|-----------|---------------|
| 4804.000 | 52.72 | 5.06 | 57.78 | 74.00 | -16.22 | peak |
| 4804.000 | 41.76 | 5.06 | 46.82 | 54.00 | -7.18 | AVG |
| 7206.000 | 46.89 | 7.03 | 53.92 | 74.00 | -20.08 | peak |
| 7206.000 | 35.97 | 7.03 | 43.00 | 54.00 | -11.00 | AVG |

Note:

8~25GHz at least have 20dB margin. No recording in the test report.

Measurement Level = Reading Level + Factor

Remark: Factor = Antenna Factor + Cable Loss–Pre-amplifier

Lowest Channel: 2402 MHz

Data rate: 3Mbps

(a) Antenna polarization: Horizontal

| Frequency (MHz) | Reading Level (dBuV) | Correct Factor (dB) | Measure Level (dBuV/m) | Limit (dBuV/m) | Over (dB) | Detector Type |
|-----------------|----------------------|---------------------|------------------------|----------------|-----------|---------------|
| 4882.000 | 52.15 | 5.14 | 57.29 | 74.00 | -16.71 | peak |
| 4882.000 | 38.23 | 5.14 | 43.37 | 54.00 | -10.63 | AVG |
| 7323.000 | 43.39 | 7.54 | 50.93 | 74.00 | -23.07 | peak |
| 7323.000 | 31.72 | 7.54 | 39.26 | 54.00 | -14.74 | AVG |

(b) Antenna polarization: Vertical

| Frequency (MHz) | Reading Level (dBuV) | Correct Factor (dB) | Measure Level (dBuV/m) | Limit (dBuV/m) | Over (dB) | Detector Type |
|-----------------|----------------------|---------------------|------------------------|----------------|-----------|---------------|
| 4882.000 | 53.37 | 5.14 | 58.51 | 74.00 | -15.49 | peak |
| 4882.000 | 41.52 | 5.14 | 46.66 | 54.00 | -7.34 | AVG |
| 7323.000 | 45.29 | 7.54 | 52.83 | 74.00 | -21.17 | peak |
| 7323.000 | 34.03 | 7.54 | 41.57 | 54.00 | -12.43 | AVG |

Note:

8~25GHz at least have 20dB margin. No recording in the test report.

Measurement Level = Reading Level + Factor

Remark: Factor = Antenna Factor + Cable Loss–Pre-amplifier

Middle Channel: 2441 MHz

Data rate: 3Mbps

(a) Antenna polarization: Horizontal

| Frequency (MHz) | Reading Level (dBuV) | Correct Factor (dB) | Measure Level (dBuV/m) | Limit (dBuV/m) | Over (dB) | Detector Type |
|-----------------|----------------------|---------------------|------------------------|----------------|-----------|---------------|
| 4960.000 | 50.70 | 5.22 | 55.92 | 74.00 | -18.08 | peak |
| 4960.000 | 39.49 | 5.22 | 44.71 | 54.00 | -9.29 | AVG |
| 7440.000 | 43.02 | 8.06 | 51.08 | 74.00 | -22.92 | peak |
| 7440.000 | 32.87 | 8.06 | 40.93 | 54.00 | -13.07 | AVG |

(b) Antenna polarization: Vertical

| Frequency (MHz) | Reading Level (dBuV) | Correct Factor (dB) | Measure Level (dBuV/m) | Limit (dBuV/m) | Over (dB) | Detector Type |
|-----------------|----------------------|---------------------|------------------------|----------------|-----------|---------------|
| 4960.000 | 52.22 | 5.22 | 57.44 | 74.00 | -16.56 | PEAK |
| 4960.000 | 41.40 | 5.22 | 46.62 | 54.00 | -7.38 | AVERAGE |
| 7440.000 | 45.55 | 8.06 | 53.61 | 74.00 | -20.39 | PEAK |
| 7440.000 | 34.75 | 8.06 | 42.81 | 54.00 | -11.19 | AVERAGE |

Note:

8~25GHz at least have 20dB margin. No recording in the test report.

Measurement Level = Reading Level + Factor

Remark: Factor = Antenna Factor + Cable Loss–Pre-amplifier

Highest channel: 2480 MHz

Data rate: 3Mbps

5.3.5 TEST RESULTS (Restricted Bands Requirements)

| | | | |
|--------------|--------------------------------------------------------------------------------------------------------------------------------------------------------------------------------------------------------------------------------------------------------------------------------------------------------------------------------------------------------------------------|--------------------|----------------------|
| EUT: | Bluetooth headset | Model Name : | B3506 |
| Temperature: | 25 °C | Test Data | 2017-01-04 |
| Pressure: | 1010 hPa | Relative Humidity: | 60% |
| Test Mode : | TX 1Mbps\ 3Mbps | Test Voltage : | DC 3.7V from battery |
| RBW/VBW | 1MHz/3MHz for Peak, 1MHz/10Hz for Average. | | |
| Note: | <ol style="list-style-type: none"> 1. The transmitter was setup to transmit at the lowest channel. Then the field strength was measured at 2310-2390 MHz. 2. The transmitter was setup to transmit at the highest channel. Then the field strength was measured at 2483.5-2500 MHz. 3. The data of 2390MHz and 2483.5MHz was the worst. | | |

| Test Mode | Ant.Pol. H/V | Freq. (MHz) | Reading | | Ant/CF CF(dB) | Act | | Limit | |
|-----------------|--------------|-------------|-------------|-----------|---------------|---------------|-------------|---------------|-------------|
| | | | Peak (dBuv) | AV (dBuv) | | Peak (dBuv/m) | AV (dBuv/m) | Peak (dBuv/m) | AV (dBuv/m) |
| Data rate 1Mbps | V | 2390 | 42.53 | 31.98 | -5.79 | 36.74 | 26.19 | 74.00 | 54.00 |
| | H | 2390 | 43.22 | 32.73 | -5.79 | 37.43 | 26.94 | 74.00 | 54.00 |
| | V | 2483.5 | 42.68 | 31.62 | -4.98 | 37.70 | 26.64 | 74.00 | 54.00 |
| | H | 2483.5 | 41.65 | 32.37 | -4.98 | 36.67 | 27.39 | 74.00 | 54.00 |
| Data rate 3Mbps | V | 2390 | 42.41 | 31.15 | -5.79 | 36.62 | 25.36 | 74.00 | 54.00 |
| | H | 2390 | 41.02 | 32.34 | -5.79 | 35.23 | 26.55 | 74.00 | 54.00 |
| | V | 2483.5 | 42.17 | 31.87 | -4.98 | 37.19 | 26.89 | 74.00 | 54.00 |
| | H | 2483.5 | 43.61 | 31.13 | -4.98 | 38.63 | 26.15 | 74.00 | 54.00 |

| | |
|---------|-----------------------------------------------------------------------------------------------------------------------------------------|
| Remark: | |
| (1) | Radiated emissions measured in frequency range above 1000MHz were made with an instrument using Peak detector mode. |
| (2) | During the measurements above 1 GHz it is taken care of that the EUT is always within the 3 dB cone of radiation BW of the used antenna |
| (3) | Corr.Factor = Antenna Factor + Cable Loss – Pre-amplifier. |

5.4 BANDWIDTH TEST

5.4.1 Applied procedures / Limit

For frequency hopping system operating in the 2400-2483.5MHz, If the 20dB bandwidth of hopping channel is greater than 25kHz, two-thirds 20dB bandwidth of hopping channel shall be a minimum limit for the hopping channel separation.

5.4.2 Test procedure

- a. The EUT was directly connected to the spectrum analyzer and antenna output port as show in the block diagram below.
- b. Span = approximately 2 to 3 times the 20 dB bandwidth, centered on a hopping channel
RBW \geq 1% of the 20 dB bandwidth, VBW \geq RBW, Sweep = auto, Detector function = peak
Trace = max hold

5.4.3 Deviation from standard

No deviation.

5.4.4 Test setup

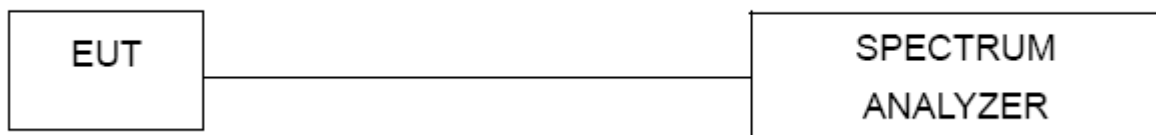

5.4.5 Test results

| | | | |
|--------------|-------------------|--------------------|----------------------|
| EUT: | Bluetooth headset | Model Name : | B3506 |
| Temperature: | 26 °C | Relative Humidity: | 53% |
| Pressure: | 1010 hPa | Test Power : | DC 3.7V from battery |
| Test Mode : | TX 1Mbps/ 3Mbps | | |

| Channel | | Channel frequency (MHz) | 20dB bandwidth (MHz) | Limit (KHz) | Conclusion |
|---------|--------|-------------------------|----------------------|-------------|------------|
| 1Mbps | Low | 2402 | 1101.9 | N/A | Pass |
| | Middle | 2441 | 1098.9 | N/A | Pass |
| | High | 2480 | 1098.9 | N/A | Pass |
| 2Mbps | Low | 2402 | 1350.0 | N/A | Pass |
| | Middle | 2441 | 1350.0 | N/A | Pass |
| | High | 2480 | 1353.6 | N/A | Pass |
| 3Mbps | Low | 2402 | 1340.4 | N/A | Pass |
| | Middle | 2441 | 1340.1 | N/A | Pass |
| | High | 2480 | 1338.0 | N/A | Pass |

CH00-1Mbps

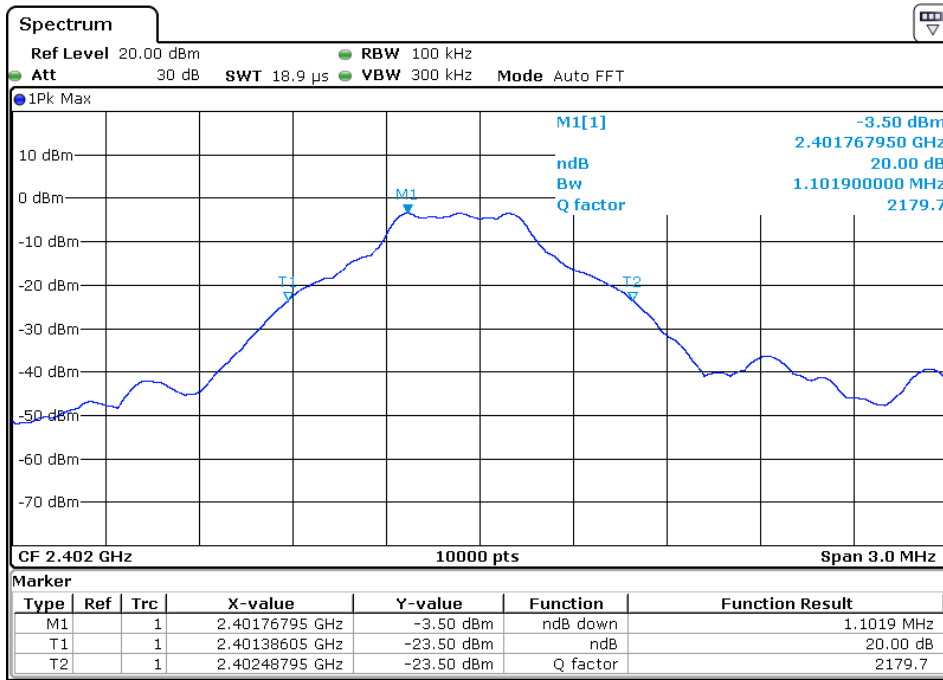

CH 39-1Mbps

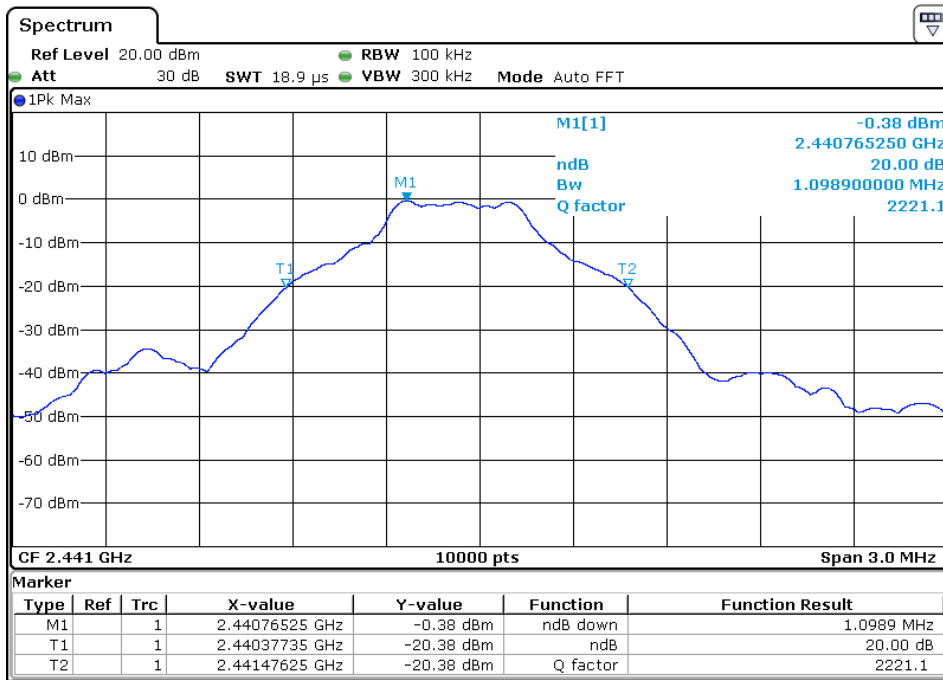

CH 78-1Mbps

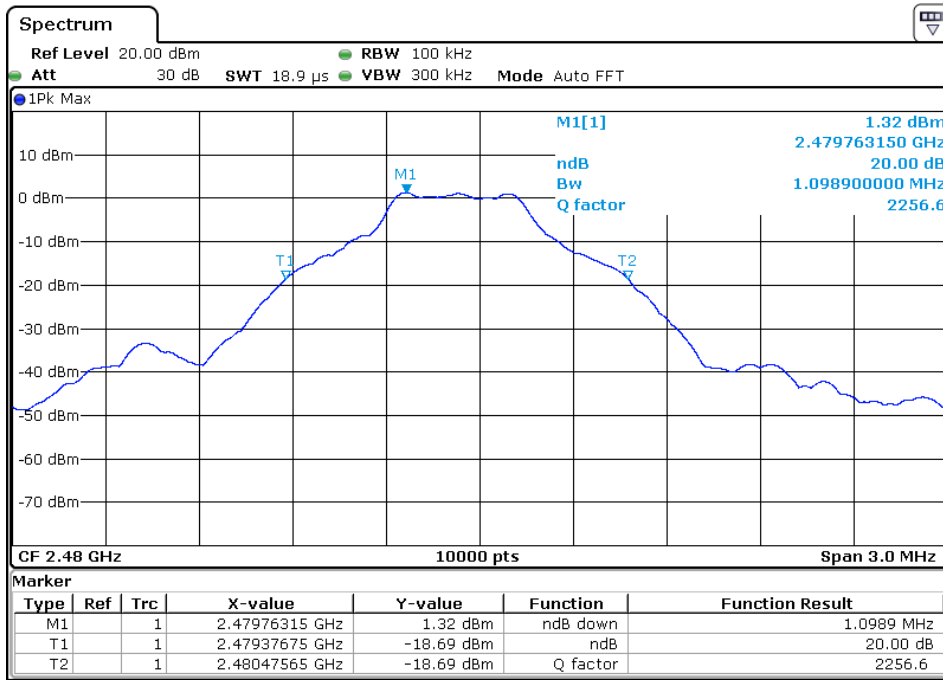

CH 00-2Mbps

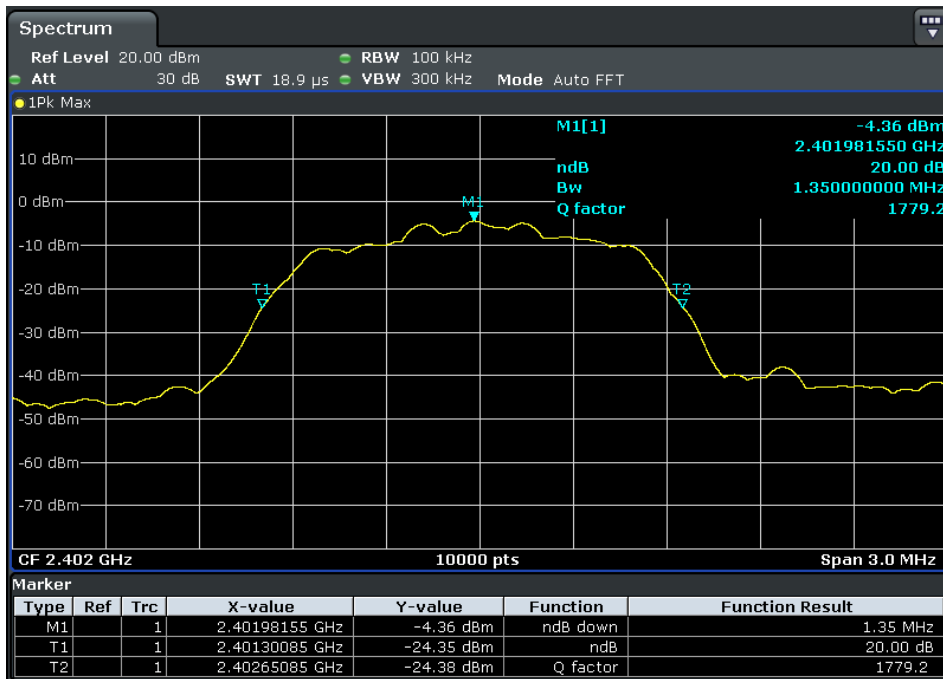

CH 39-2Mbps

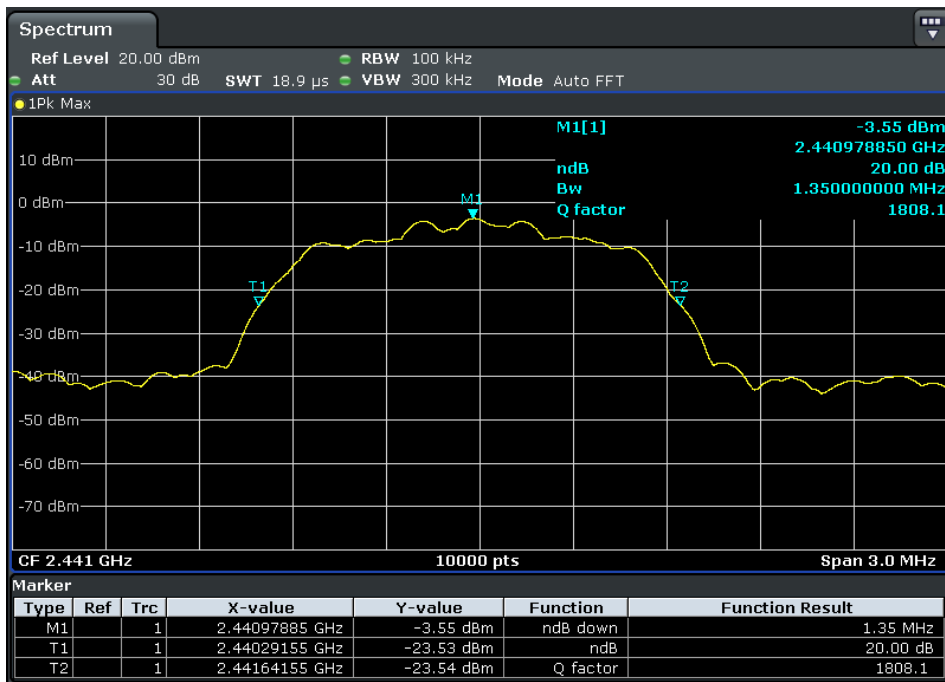

CH 78-2Mbps

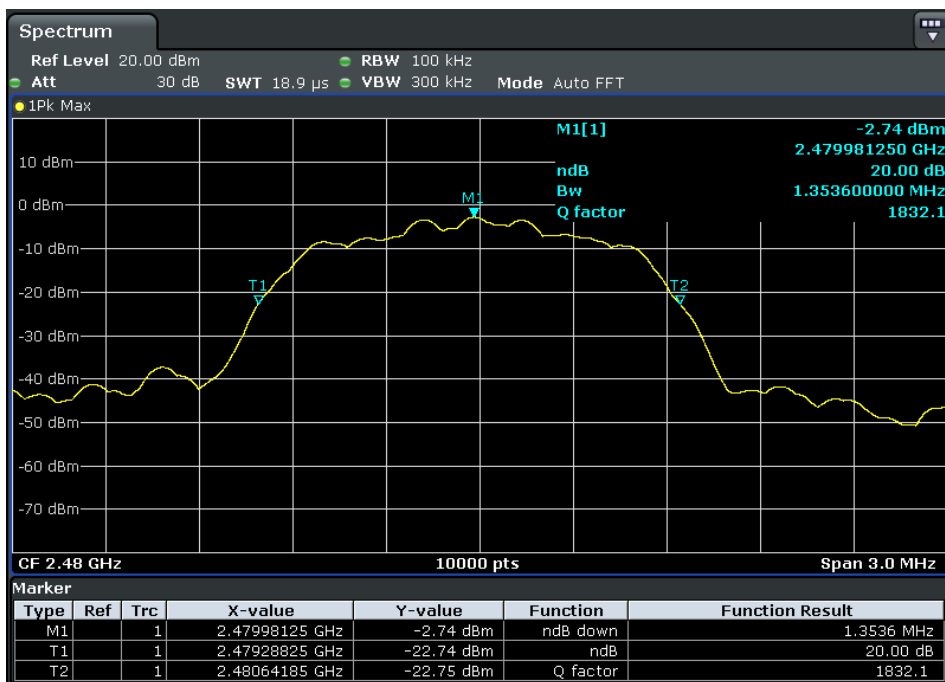

CH 00-3Mbps

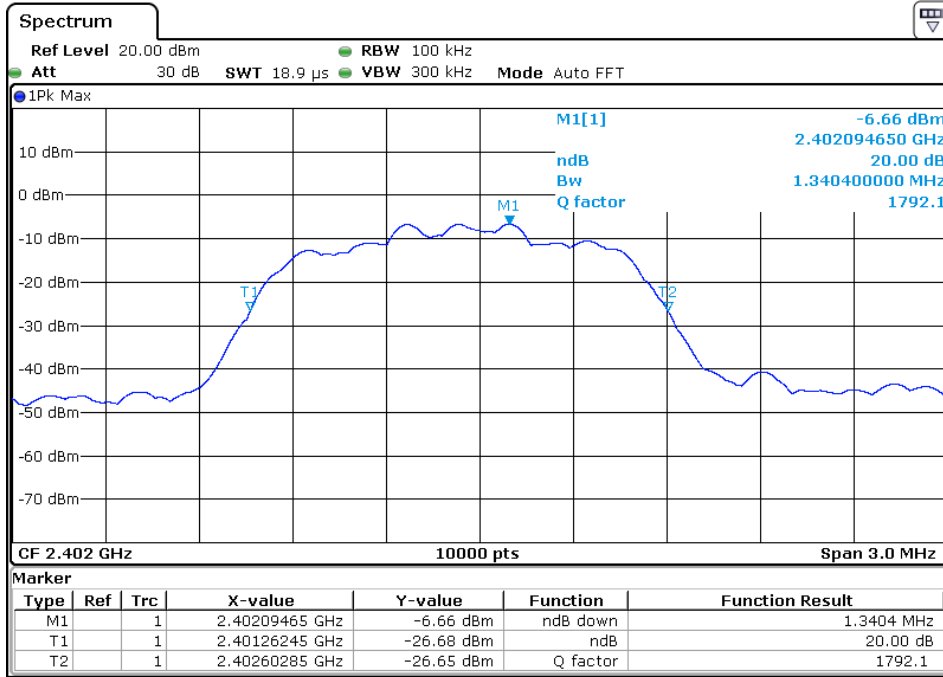

CH 39-3Mbps

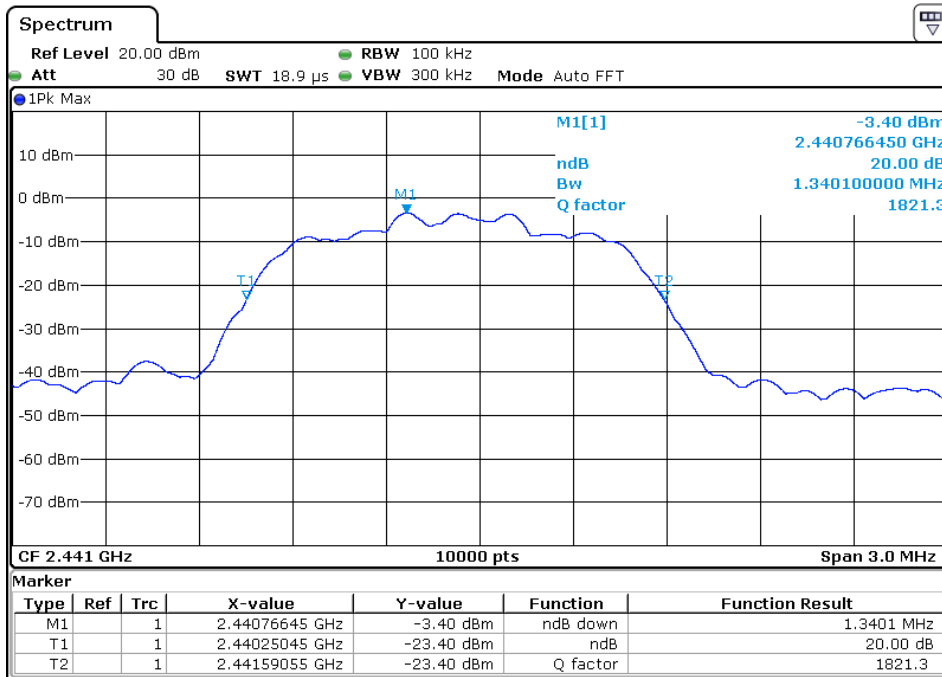

CH 78-3Mbps

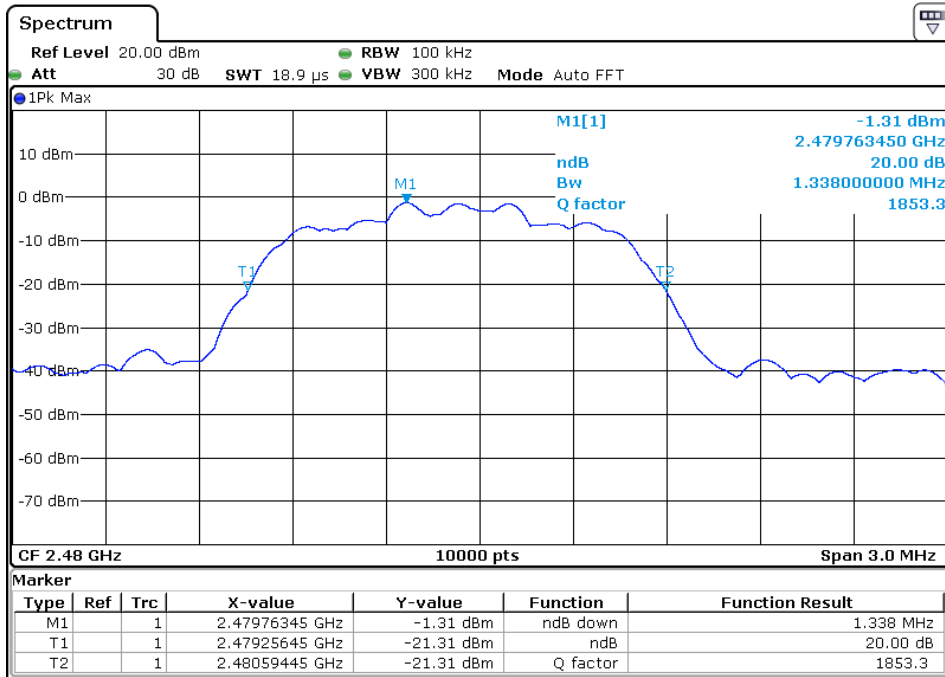

5.5 Carrier Frequencies Separated

5.5.1 Applied procedures / Limit

15.247(a) (1) Frequency hopping systems shall have hopping channel carrier frequencies separated by a minimum of 25 kHz or the 20 dB bandwidth of the hopping channel, whichever is greater. Alternatively, frequency hopping systems operating in the 2400-2483.5 MHz band may have hopping channel carrier frequencies that are separated by 25 kHz or two-thirds of the 20 dB bandwidth of the hopping channel, whichever is greater, provided the systems operate with an output power no greater than 125 mW.

5.5.2 Test procedure

- (1) Connected the antenna port to the Spectrum Analyzer, set the Spectrum Analyzer as
Span = wide enough to capture the peaks of two adjacent channels, Resolution (or IF) Bandwidth (RBW) \geq 1% of the span, Video (or Average) Bandwidth (VBW) \geq RBW
Sweep = auto, Detector function = peak, Trace = max hold
- (2) The EUT should be transmitting at its maximum data rate. Use the marker-delta function to determine the separation between the peaks of the adjacent channels.
- (3) The above procedure shall be repeated at the lowest, the middle, and the highest frequency of the stated frequency range with modulated mode. also shall be performed at different modes of operation.

5.5.3 Deviation from standard

No deviation.

5.5.4 Test setup

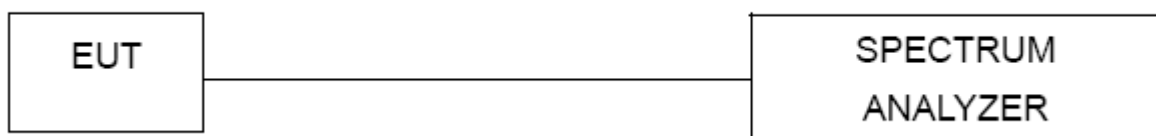

5.5.5 Test results

| | | | |
|--------------|-------------------|--------------------|----------------------|
| EUT: | Bluetooth headset | Model Name : | B3506 |
| Temperature: | 26 °C | Relative Humidity: | 53% |
| Pressure: | 1010 hPa | Test Power : | DC 3.7V from battery |
| Test Mode : | TX 1Mbps/ 3Mbps | | |

| Channel | | Channel frequency (MHz) | Channel Separation (MHz) | Conclusion |
|---------|---------|-------------------------|--------------------------|------------|
| 1Mbps | Low | 2402 | 0.9986 | Pass |
| | Middle | 2441 | 0.9986 | Pass |
| | Highest | 2480 | 0.9986 | Pass |
| 3Mbps | Low | 2402 | 1.0029 | Pass |
| | Middle | 2441 | 1.0072 | Pass |
| | Highest | 2480 | 1.0029 | Pass |

Ch. Separation >2/3(20dB bandwidth)

CH 00-1Mbps

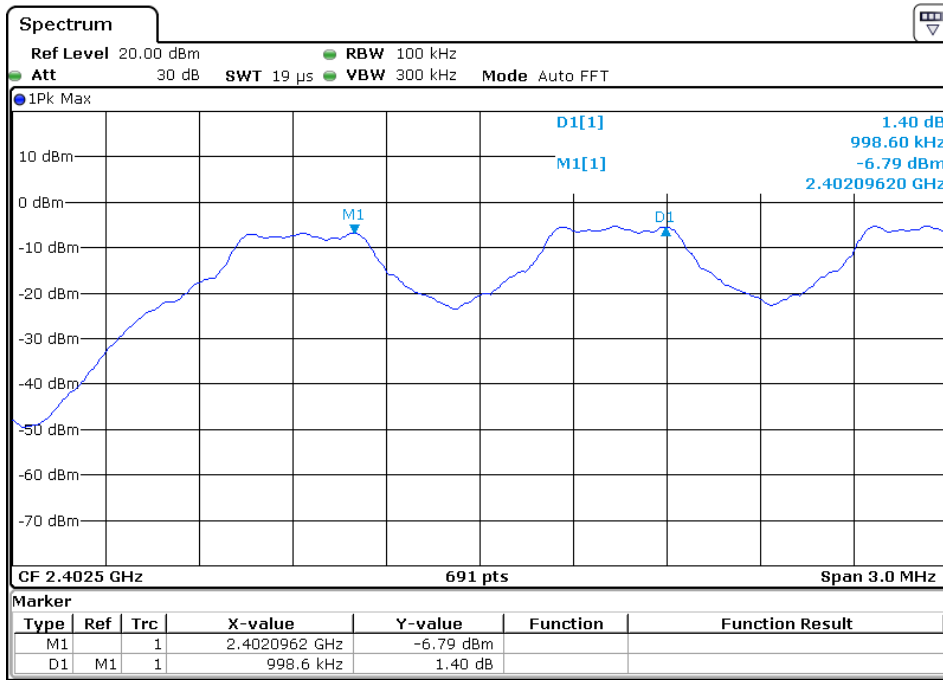

CH 39-1Mbps

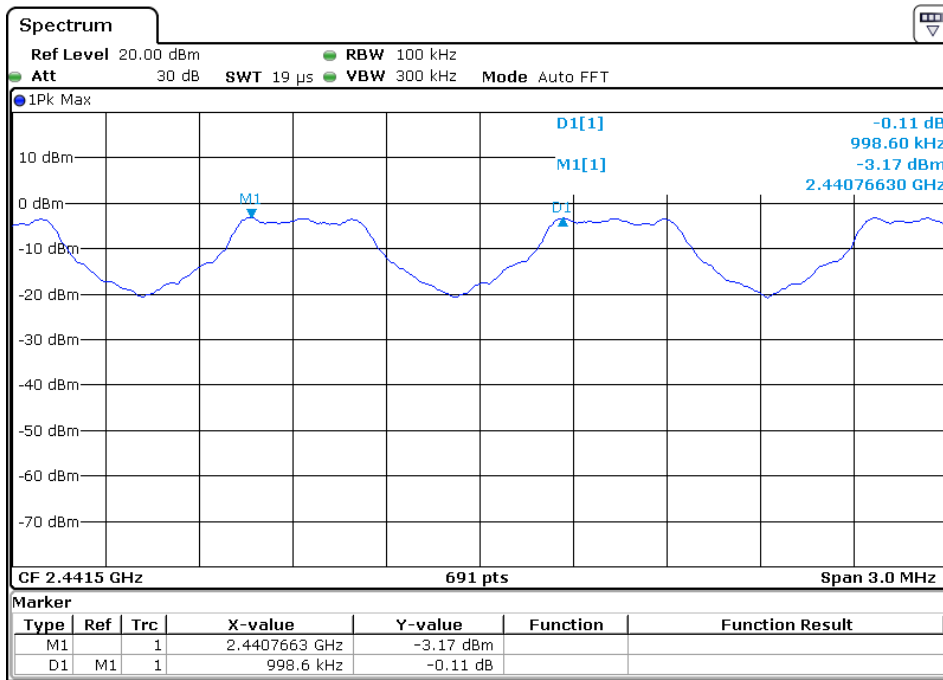

CH 78-1Mbps

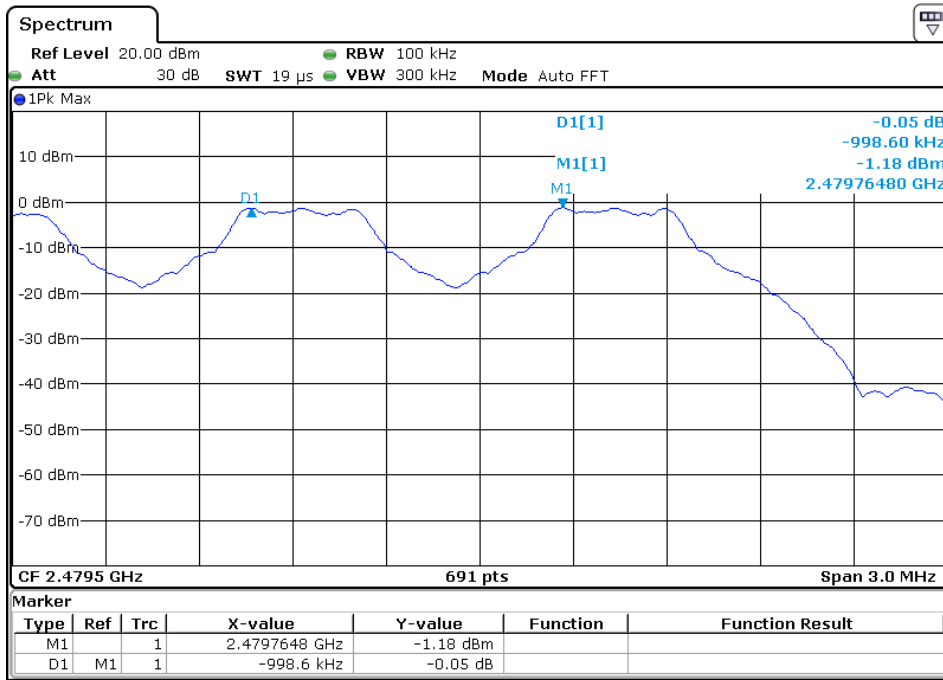

CH 00-3Mbps

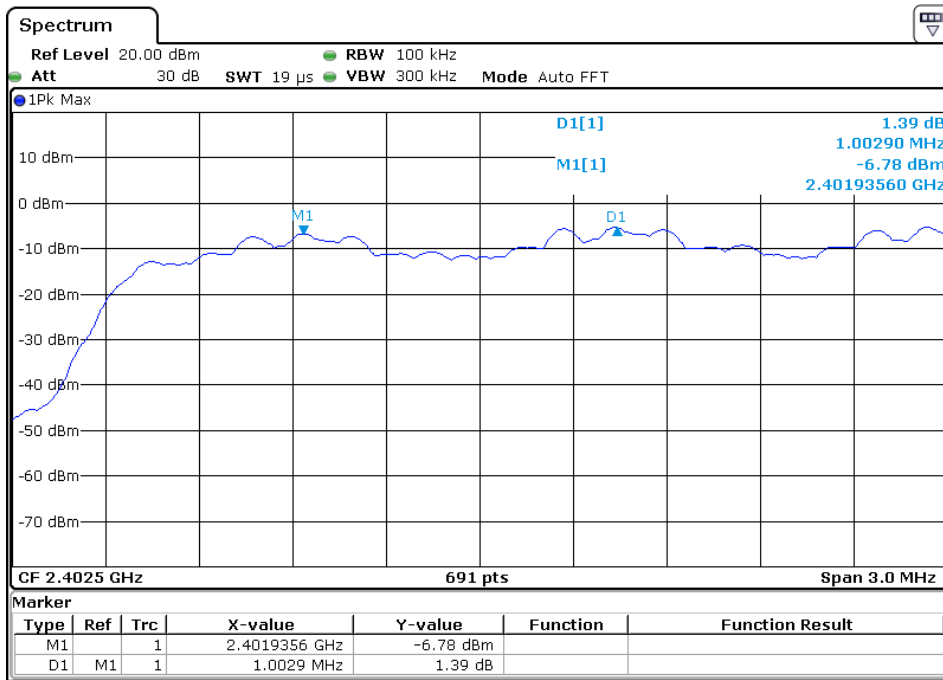

CH 39-3Mbps

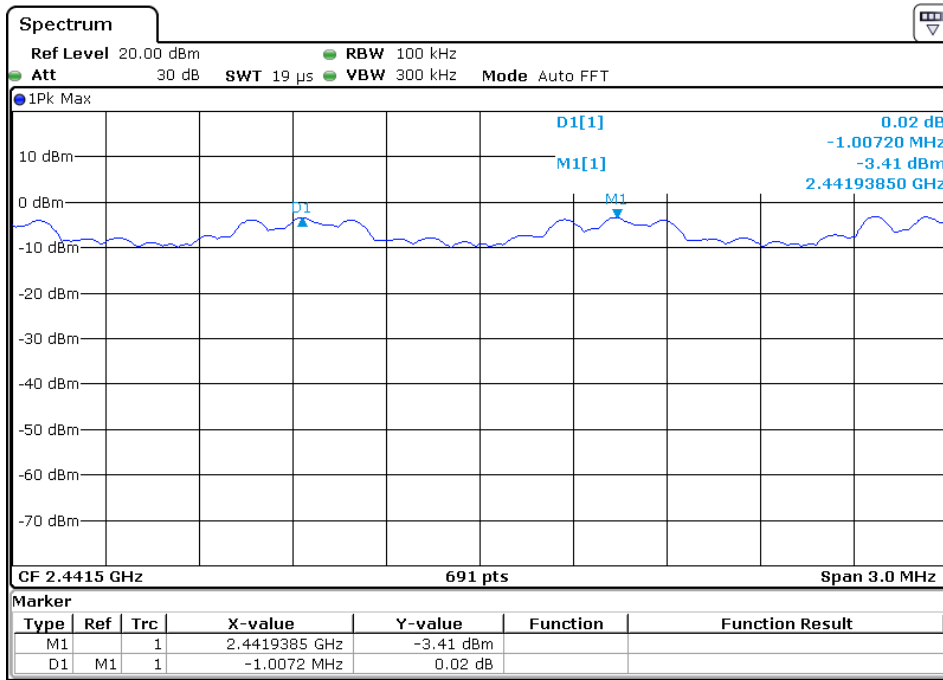

CH 78-3Mbps

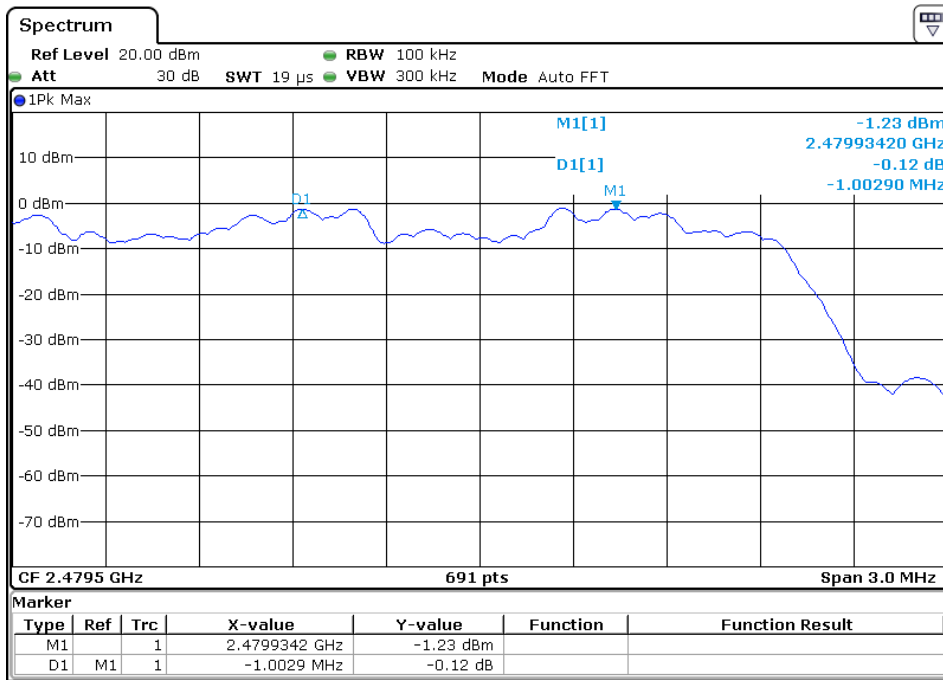

5.6 Hopping Channel Number

5.6.1 Applied procedures / Limit

15.247(a) (1) (iii) Frequency hopping systems in the 2400-2483.5 MHz band shall use at least 15 channels. The average time of occupancy on any channel shall not be greater than 0.4 seconds within a period of 0.4 seconds multiplied by the number of hopping channels employed. Frequency hopping systems may avoid or suppress transmissions on a particular hopping frequency provided that a minimum of 15 channels are used.

5.6.2 Test procedure

- (1) Connected the antenna port to the Spectrum Analyzer , set the Spectrum Analyzer as
Span = the frequency band of operation, $RBW \geq 1\%$ of the span, $VBW \geq RBW$ Sweep = auto
Detector function = peak, Trace = max hold
- (2) The EUT should be have its hopping function enabled. Maxhold and record hopping channels It may prove necessary to break the span up to sections, in order to clearly show all of the hopping frequencies.

5.6.3 Deviation from standard

No deviation.

5.6.4 Test setup

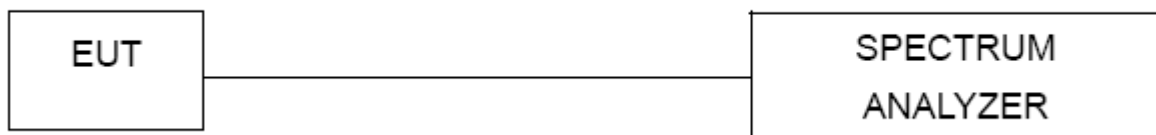

5.6.5 Test result

| Hopping Channel Number result | | |
|--------------------------------------|-------|----------------------|
| Operating Mode: 1Mbps/ 3Mbps Mode | | Test date:2017-01-04 |
| Result | Limit | Conclusion |
| 79 | 15 | Pass |

| | | | |
|--------------|-------------------|--------------------|----------------------|
| EUT: | Bluetooth headset | Model Name : | B3506 |
| Temperature: | 26 °C | Relative Humidity: | 53% |
| Pressure: | 1010 hPa | Test Power : | DC 3.7V from battery |
| Test Mode : | TX 1Mbps/ 3Mbps | | |

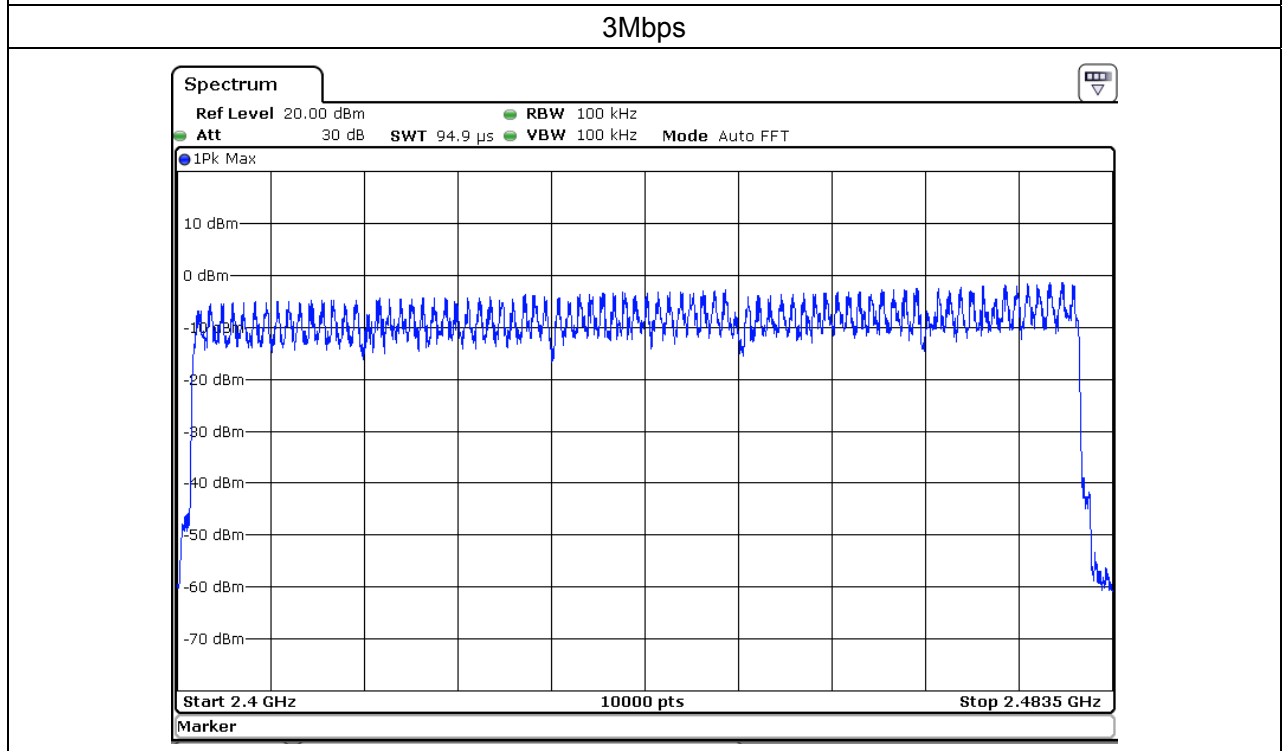
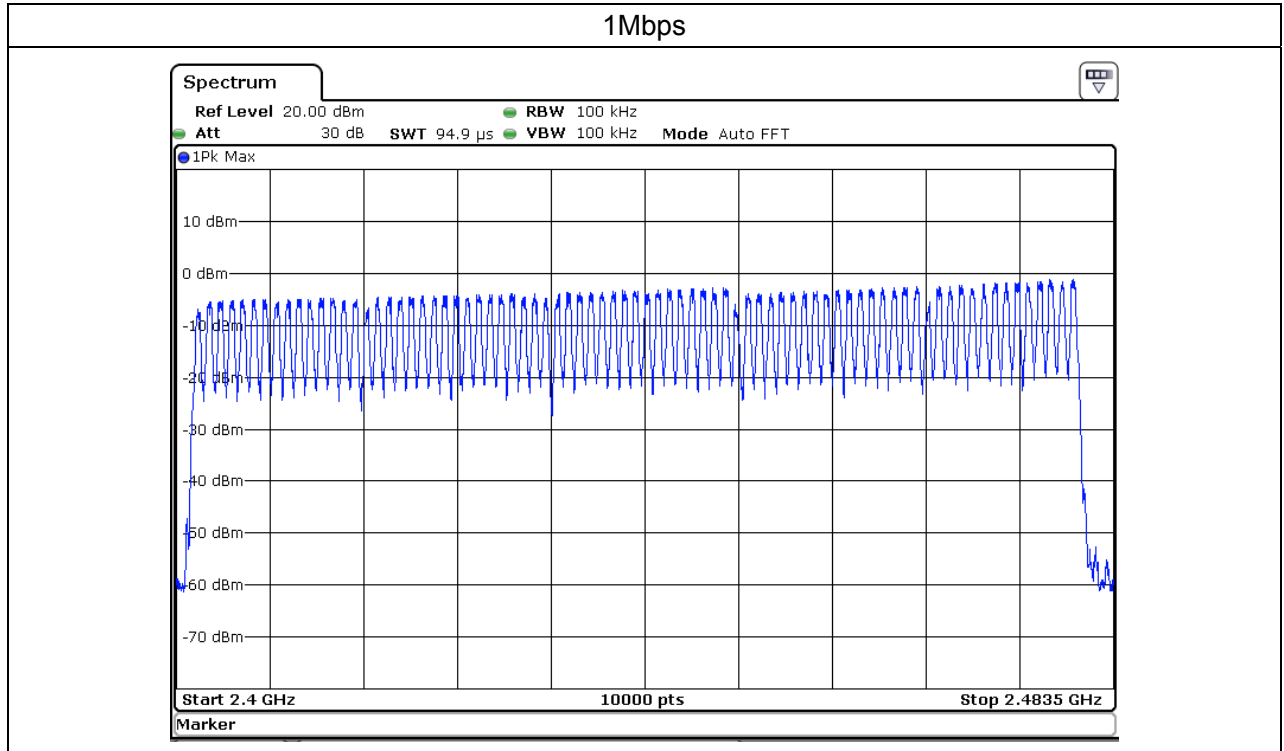

5.7 Dwell time

5.7.1 Applied procedures / Limit

15.247(a) (1) (iii) Frequency hopping systems in the 2400-2483.5 MHz band shall use at least 15 channels. The average time of occupancy on any channel shall not be greater than 0.4 seconds within a period of 0.4 seconds multiplied by the number of hopping channels employed. Frequency hopping systems may avoid or suppress transmissions on a particular hopping frequency provided that a minimum of 15 channels are used.

5.7.2 Test procedure

- (1) Place the EUT on the table in the chamber or connect the antenna port of the EUT to spectrum analyzer and set it in transmitting mode.
- (2) Set RBW of spectrum analyzer to 1MHz, VBW \geq RBW
- (3) Use a video trigger with the trigger level set to enable triggering only on full pulses.
- (4) Sweep Time is more than once pulse time.
- (5) Set the center frequency on any frequency would be measure and set the frequency span to zero span.
- (6) Measure the maximum time duration of one single pulse.
- (7) Set the EUT for DH5, DH3 and DH1 packet transmitting.
- (8) Measure the maximum time duration of one single pulse.
- (9) A Period Time = $79 \times 0.4 = 31.6$ S
DH1 Time Slot: Reading * $(1600/2) \times 31.6/79$
DH3 Time Slot: Reading * $(1600/4) \times 31.6/79$
DH5 Time Slot: Reading * $(1600/6) \times 31.6/79$

5.7.3 Deviation from standard

No deviation.

5.7.4 Test setup



5.7.5 Test result

| | | | |
|--------------|-------------------------------|--------------------|----------------------|
| EUT: | Bluetooth headset | Model Name : | B3506 |
| Temperature: | 26 °C | Relative Humidity: | 53% |
| Pressure: | 1010 hPa | Test Power : | DC 3.7V from battery |
| Test Mode : | CH00-DH1/DH3/DH5 (1Mbps Mode) | | |

| Data Packet | Frequency | Pulse Duration (ms) | Dwell Time (ms) | Limits (s) |
|-------------|-----------|---------------------|-----------------|------------|
| DH1 | 2402 MHz | 0.457 | 146.240 | 0.4000 |
| DH3 | 2402 MHz | 1.704 | 272.640 | 0.4000 |
| DH5 | 2402 MHz | 2.956 | 315.306 | 0.4000 |

CH 00- DH1

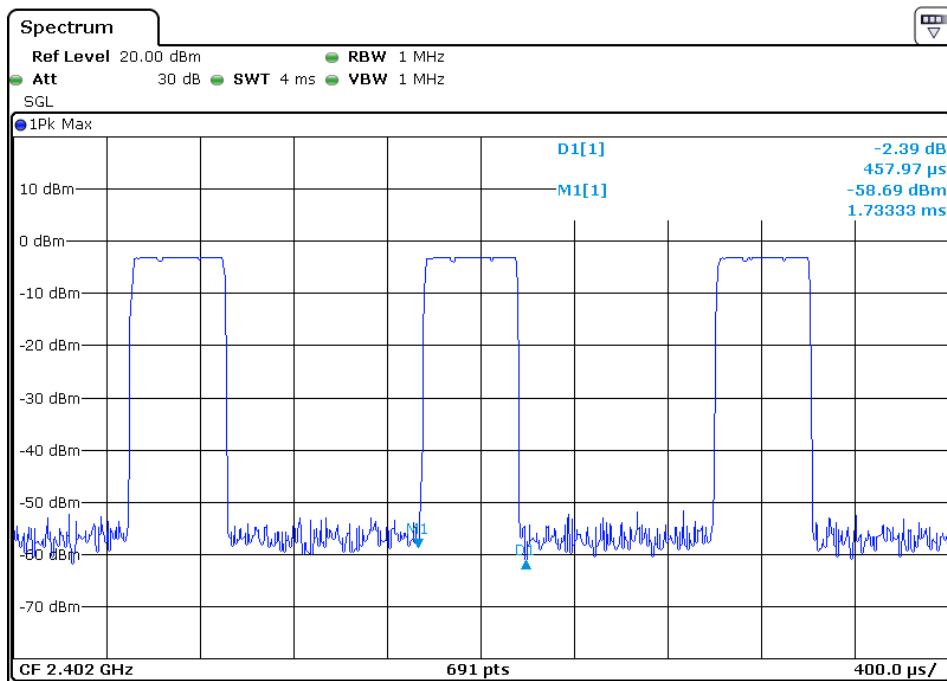

CH 00- DH3

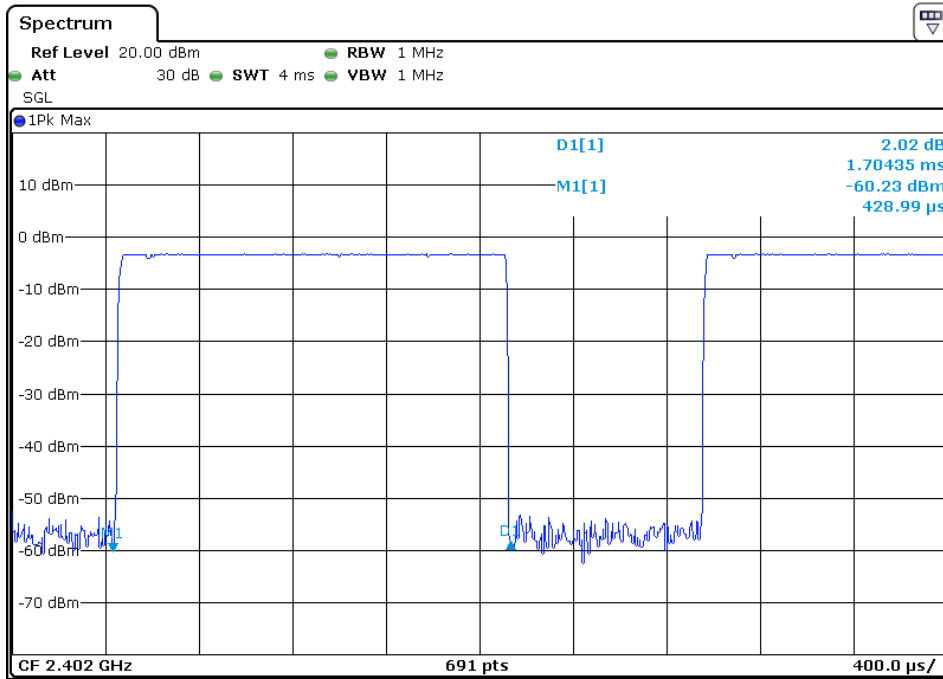

CH 00- DH5

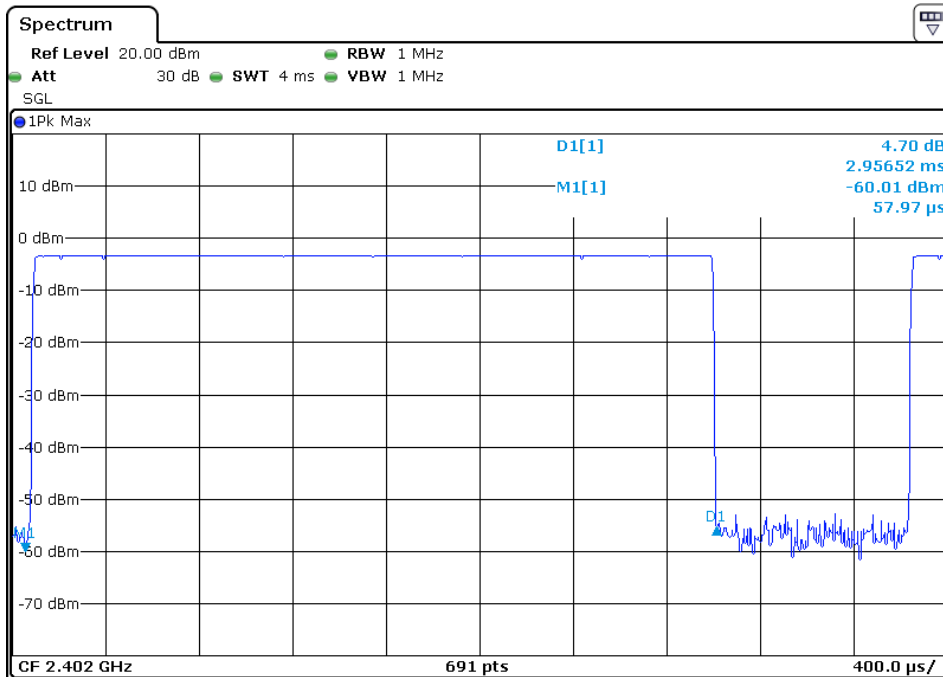

| | | | |
|--------------|----------------------------------|--------------------|----------------------|
| EUT: | Bluetooth headset | Model Name : | B3506 |
| Temperature: | 26 °C | Relative Humidity: | 53% |
| Pressure: | 1010 hPa | Test Power : | DC 3.7V from battery |
| Test Mode : | CH00-3DH1/3DH3/3DH5 (3Mbps Mode) | | |

| Data Packet | Frequency | Pulse Duration (ms) | Dwell Time (ms) | Limits (s) |
|-------------|-----------|---------------------|-----------------|------------|
| 3DH1 | 2402 MHz | 0.463 | 148.160 | 0.4000 |
| 3DH3 | 2402 MHz | 1.698 | 271.680 | 0.4000 |
| 3DH5 | 2402 MHz | 2.956 | 315.306 | 0.4000 |

CH 00- DH1

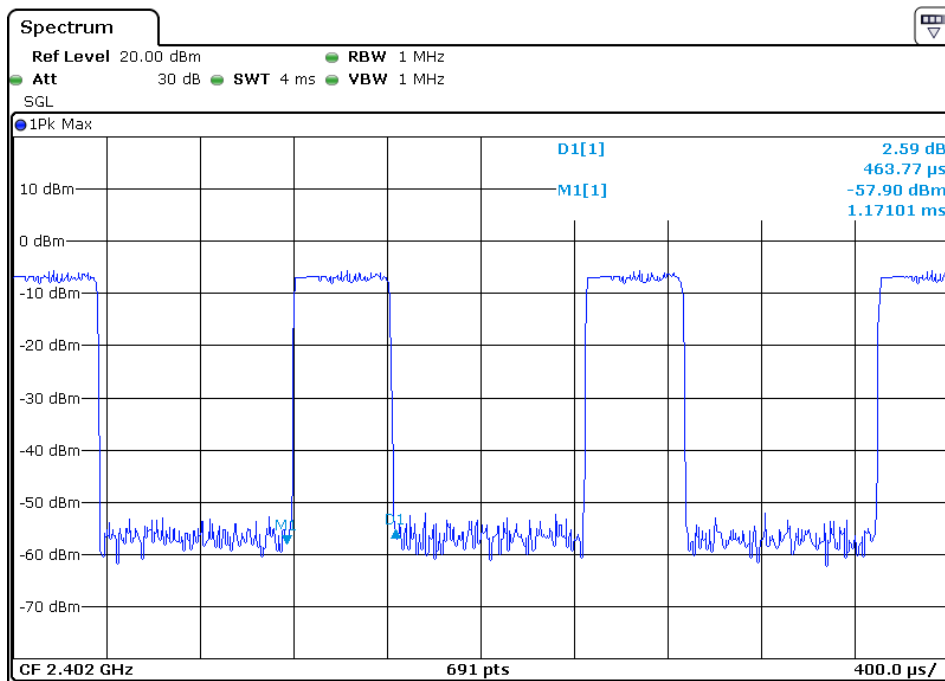

CH 00- DH3

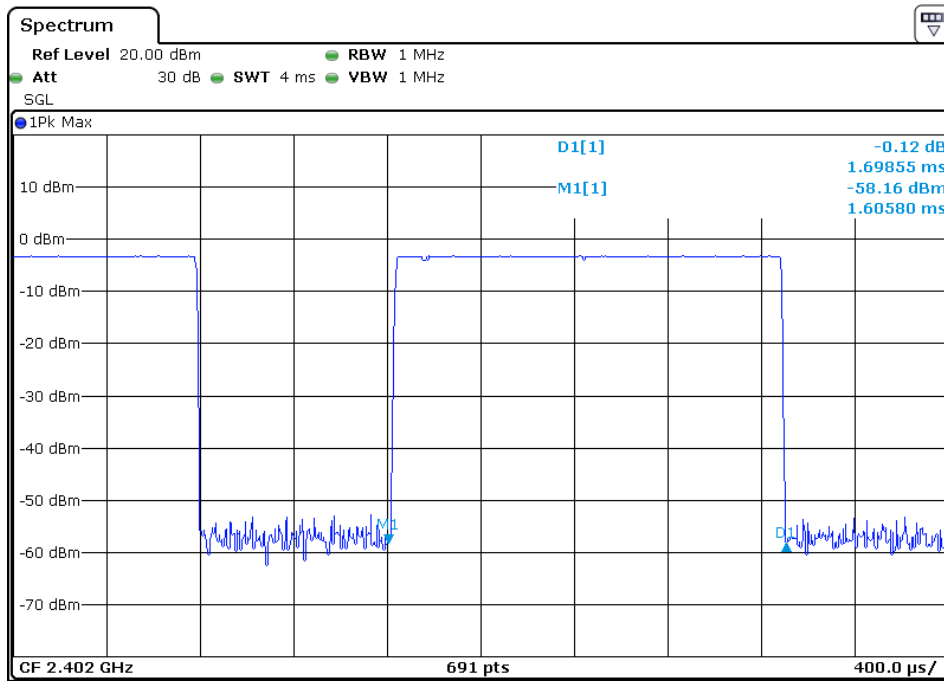

CH 00- DH5

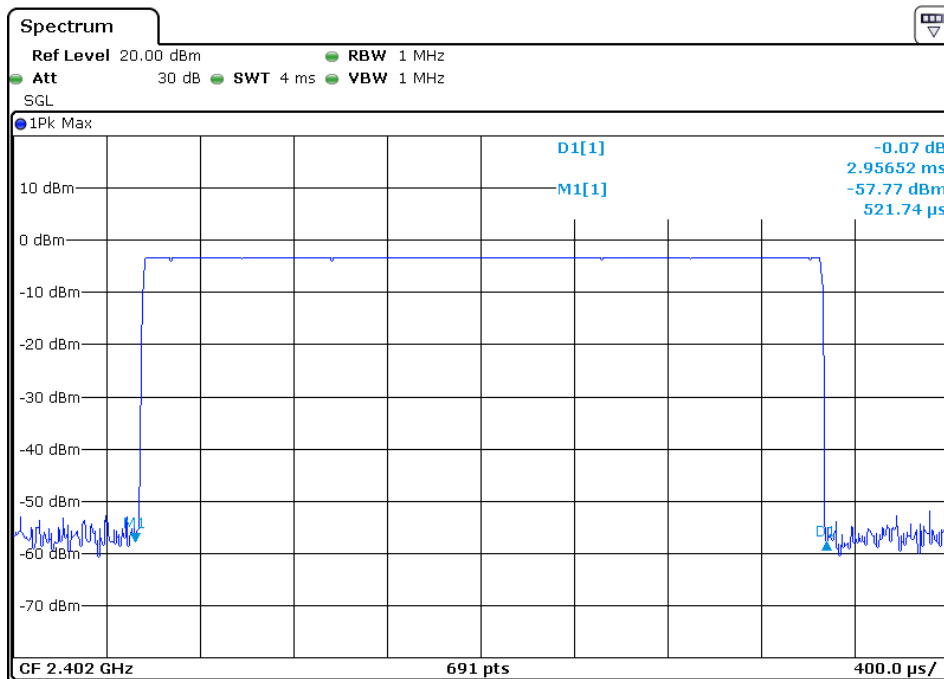

5.8 Maximum Peak Output Power

5.8.1 Applied procedures / Limit

15.247(a) (1) Frequency hopping systems shall have hopping channel carrier frequencies separated by a minimum of 25 kHz or the 20 dB bandwidth of the hopping channel, whichever is greater. Alternatively, frequency hopping systems operating in the 2400–2483.5 MHz band may have hopping channel carrier frequencies that are separated by 25 kHz or two-thirds of the 20 dB bandwidth of the hopping channel, whichever is greater, provided the systems operate with an output power no greater than 125 mW.

15.247(b) (1) For frequency hopping systems operating in the 2400-2483.5 MHz band employing at least 75 non-overlapping hopping channels, and all frequency hopping systems in the 5725-5850 MHz band: 1watt. For all other frequency hopping systems in the 2400-2483.5 MHz band: 0.125 watts.

5.8.2 Test procedure

- (1) Connected the antenna port to the Spectrum Analyzer, set the Spectrum Analyzer as
Span = approximately 5 times the 20 dB bandwidth, centered on a hopping channel
RBW > the 20 dB bandwidth of the emission being measured, VBW \geq RBW, Sweep = auto
Detector function = peak, Trace = max hold
- (2) The EUT should be transmitting at its maximum data rate. Allow the trace to stabilize. Use the marker-to-peak function to set the marker to the peak of the emission. The indicated level is the peak output power.
- (3) The above procedure shall be repeated at the lowest, the middle, and the highest frequency of the stated frequency range with modulated mode. Also shall be performed at different modes of operation.

5.8.3 Deviation from standard

No deviation.

5.8.4 Test setup



5.8.5 Test results

| | | | |
|--------------------------------------------------------------------------------|-------------------|--------------------|----------------------|
| EUT: | Bluetooth headset | Model Name : | B3506 |
| Temperature: | 26 °C | Relative Humidity: | 60% |
| Pressure: | 1010 hPa | Test Voltage : | DC 3.7V from battery |
| Test Mode : | TX | | |
| Note: All the data rates have be tested and the worst-case as the table below. | | | |

| Test Mode | Frequency | Peak Output Power (dBm) | Limit (dBm) | Result |
|----------------------|-----------|-------------------------|-------------|--------|
| Data rate 1Mbps | 2402 MHz | -3.33 | 21 | Pass |
| | 2441 MHz | -0.30 | 21 | Pass |
| | 2480 MHz | -1.22 | 21 | Pass |
| Data rate 2Mbps | 2402 MHz | -3.03 | 21 | Pass |
| | 2441 MHz | -2.06 | 21 | Pass |
| | 2480 MHz | -1.68 | 21 | Pass |
| Data rate 3Mbps | 2402 MHz | -5.29 | 21 | Pass |
| | 2441 MHz | -2.27 | 21 | Pass |
| | 2480 MHz | 0.01 | 21 | Pass |
| Cable loss = 0.5 dBm | | | | |

CH 00-1Mbps

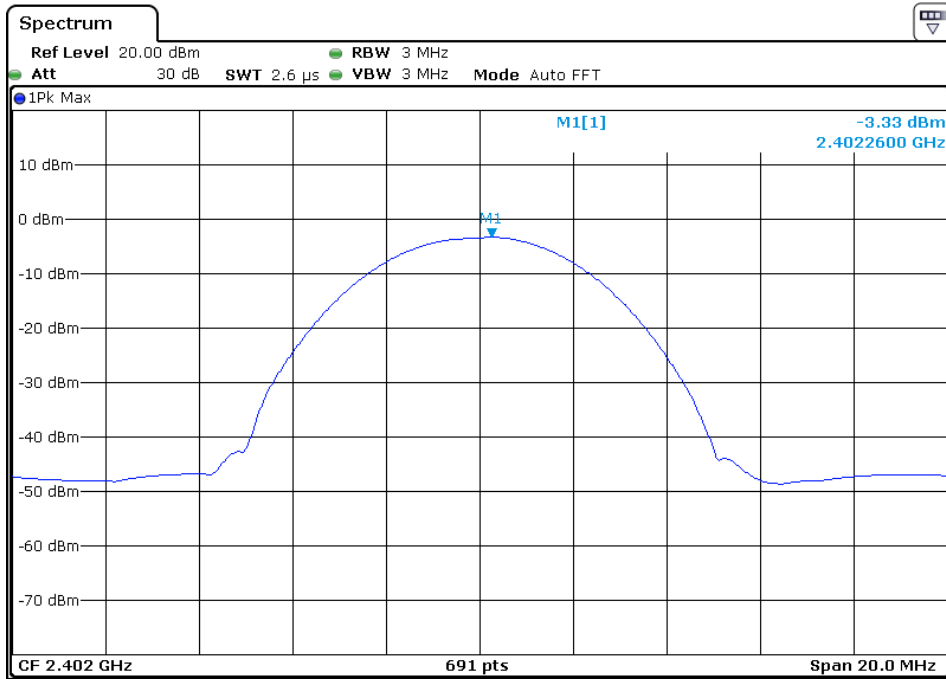

CH 39-1Mbps

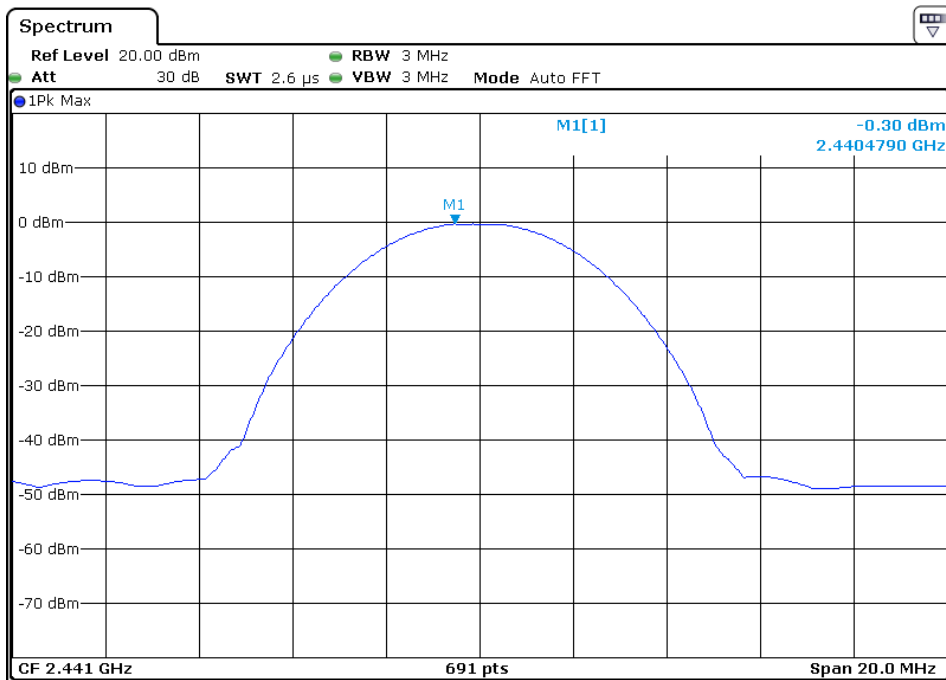

CH 78-1Mbps

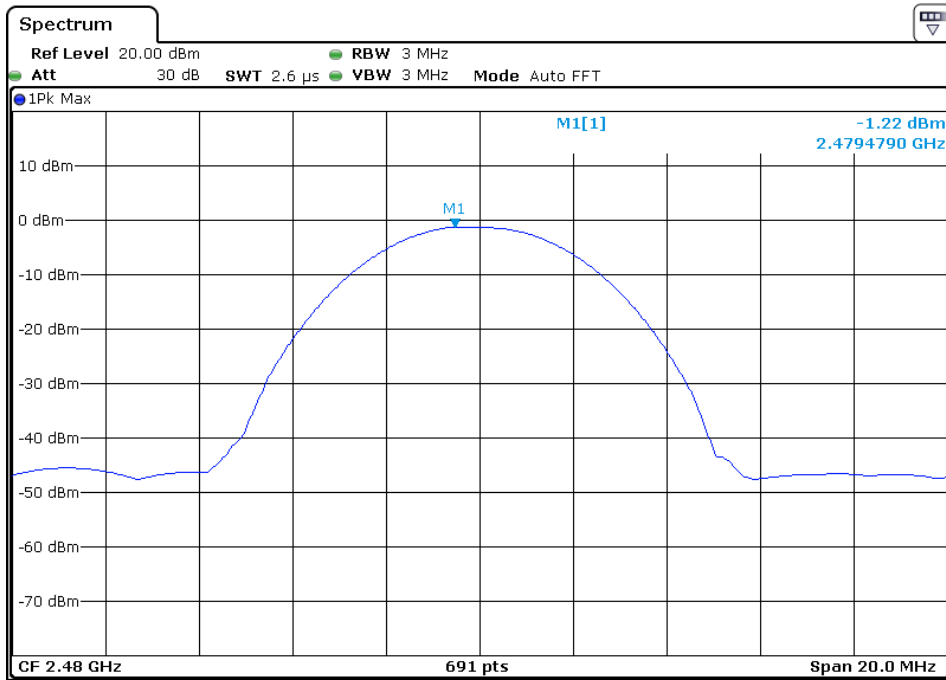

CH 00-2Mbps

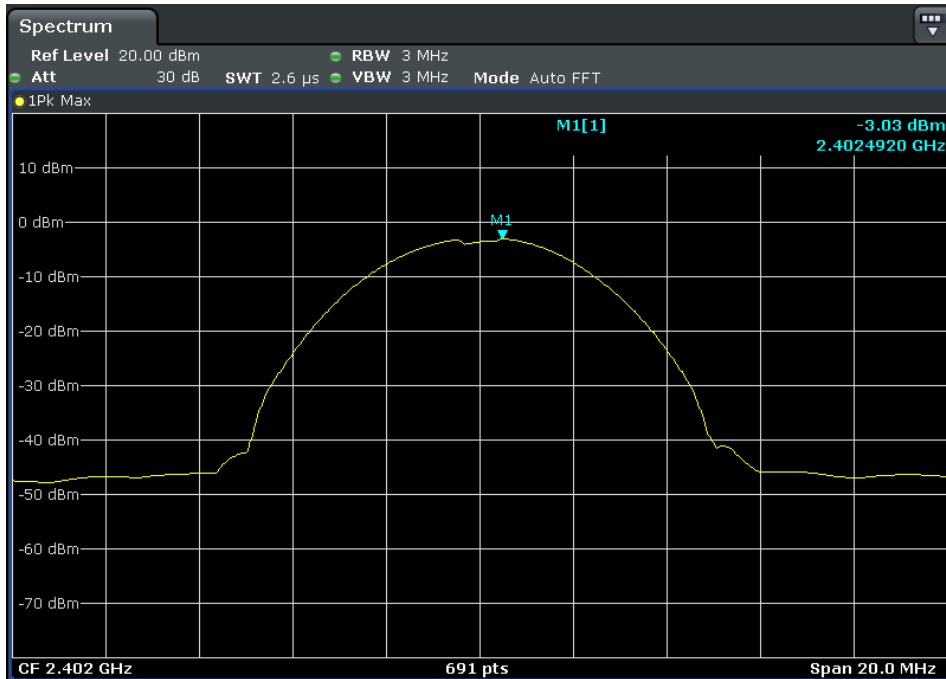

CH 39-2Mbps

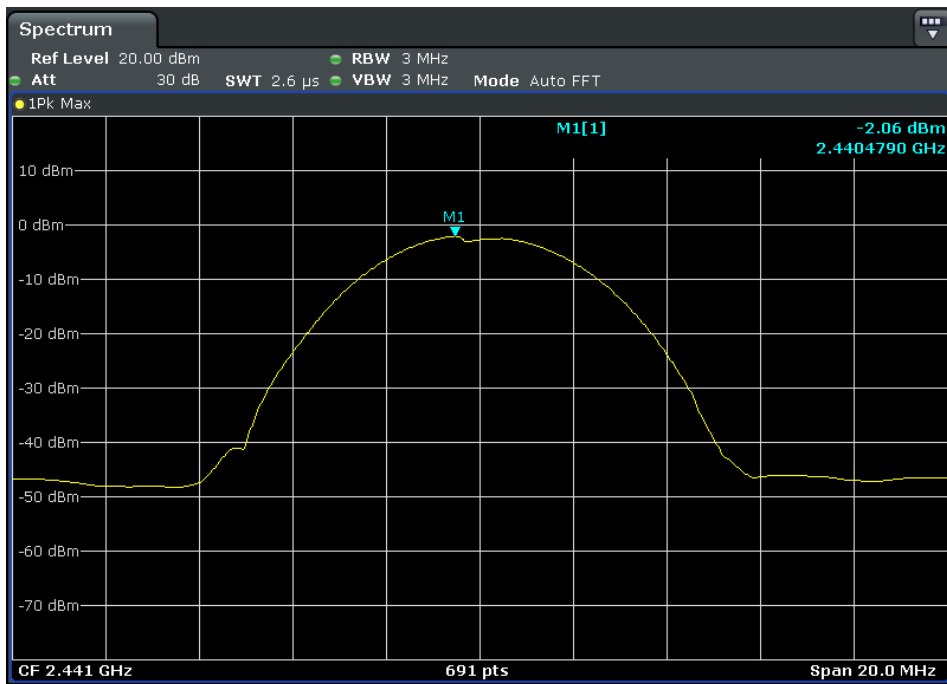

CH 78-2Mbps

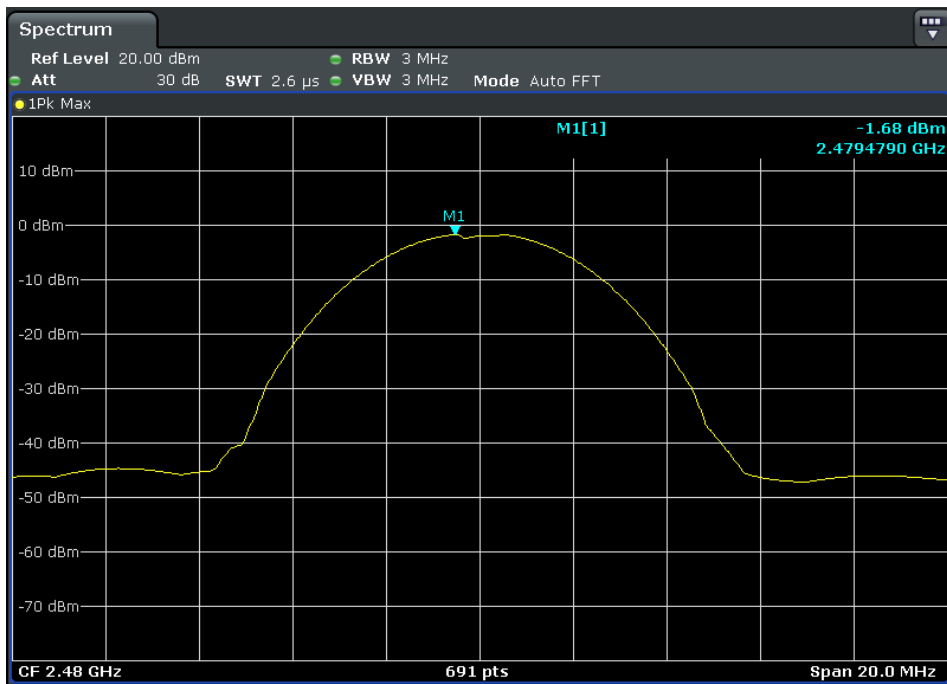

CH 00-3Mbps

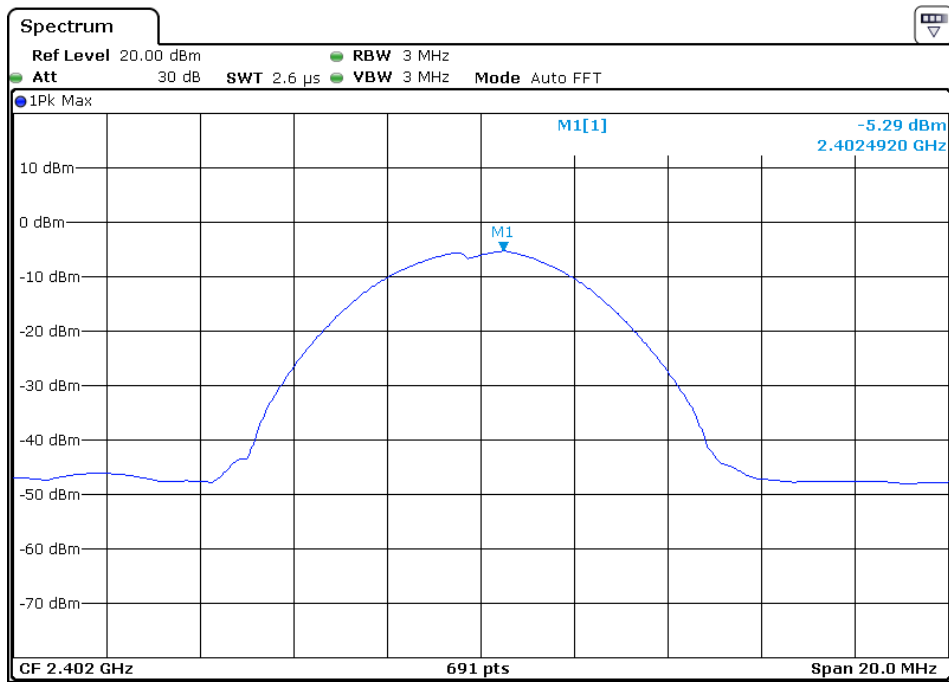

CH 39-3Mbps

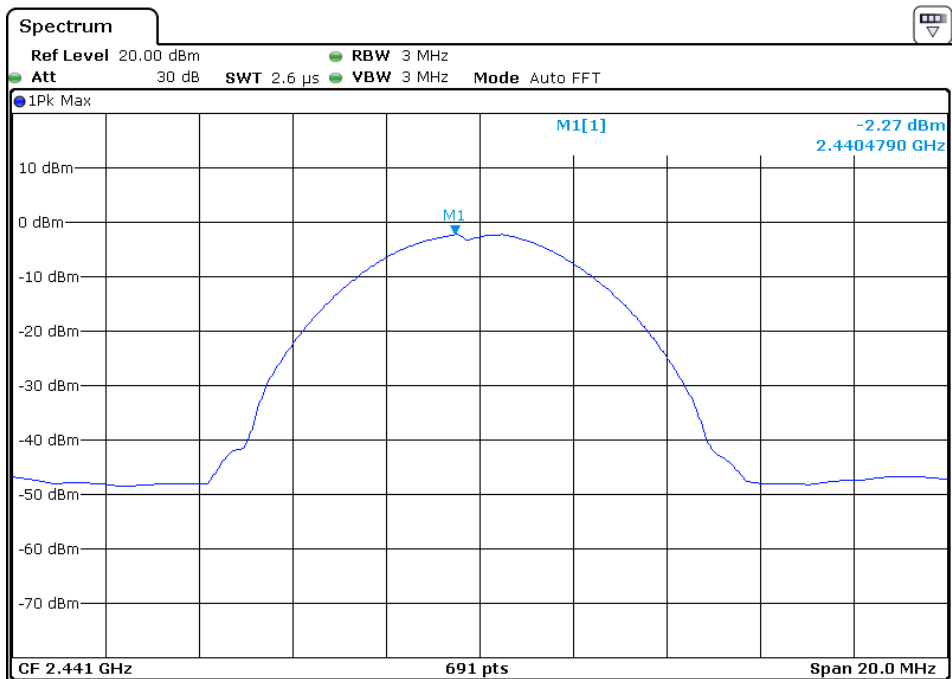

CH 78-3Mbps

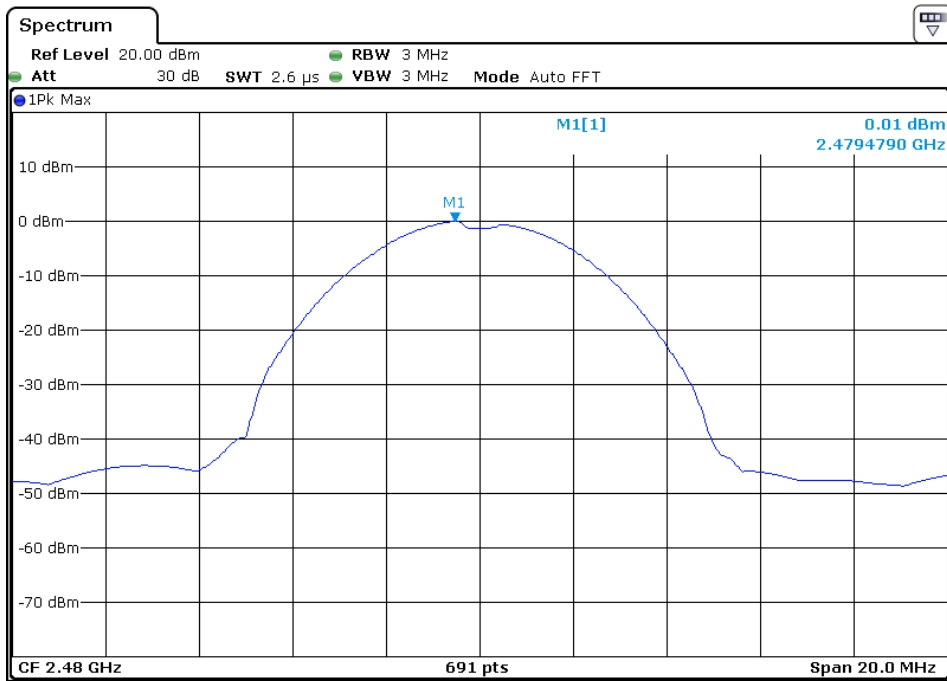

5.9 Band edge

5.9.1 Applied procedures / Limit

15.247(d) In any 100 kHz bandwidth outside the frequency band in which the spread spectrum or digitally modulated intentional radiator is operating, the radio frequency power that is produced by the intentional radiator shall be at least 20 dB below that in the 100 kHz bandwidth within the band that contains the highest level of the desired power, based on either an RF conducted or a radiated measurement, provided the transmitter demonstrates compliance with the peak conducted power limits. If the transmitter complies with the conducted power limits based on the use of RMS averaging over a time interval, as permitted under paragraph (b)(3) of this section, the attenuation required under this paragraph shall be 30 dB instead of 20 dB. Attenuation below the general limits specified in Section 15.209(a) is not required. In addition, radiated emissions which fall in the restricted bands, as defined in Section 15.205(a), must also comply with the radiated emission limits specified in Section 15.209(a) (see Section 15.205(c)).

5.9.2 Test procedure

- a. The EUT was directly connected to the spectrum analyzer and antenna output port as show in the block diagram below.
- b. Span = wide enough to capture the peak level of the emission operating on the channel closest to the bandedge, as well as any modulation products which fall outside of the authorized band of operation, RBW \geq 1% of the span, VBW \geq RBW, Sweep = auto, Detector function = peak, Trace = max hold

5.9.3 Deviation from standard

No deviation.

5.9.4 Test setup



5.9.5 Test results

CH00 (Lower) Data rate 1Mbps

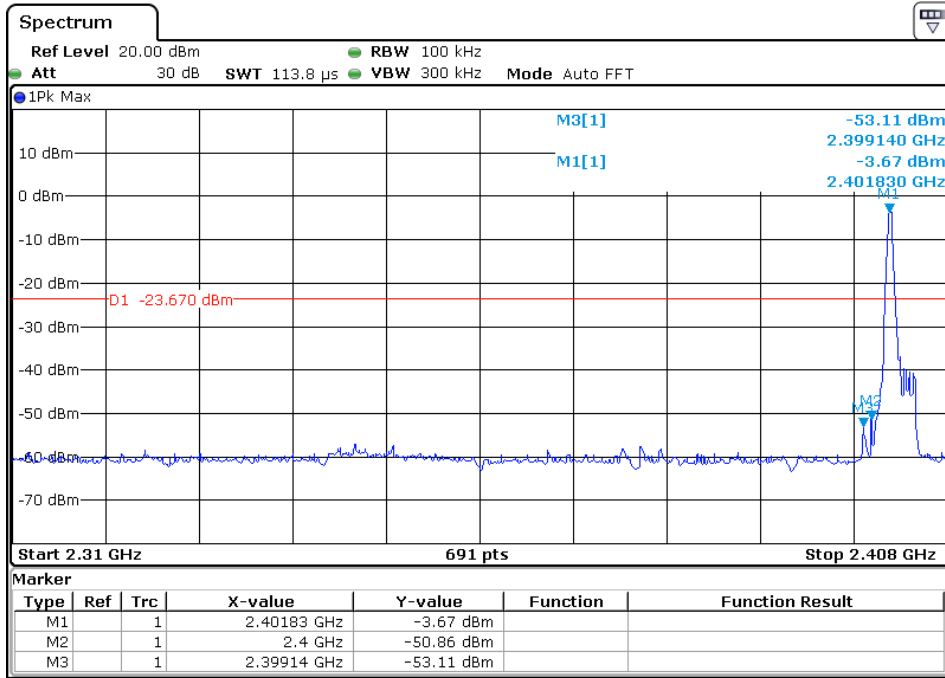

CH 78 (Upper) Data rate 1Mbps

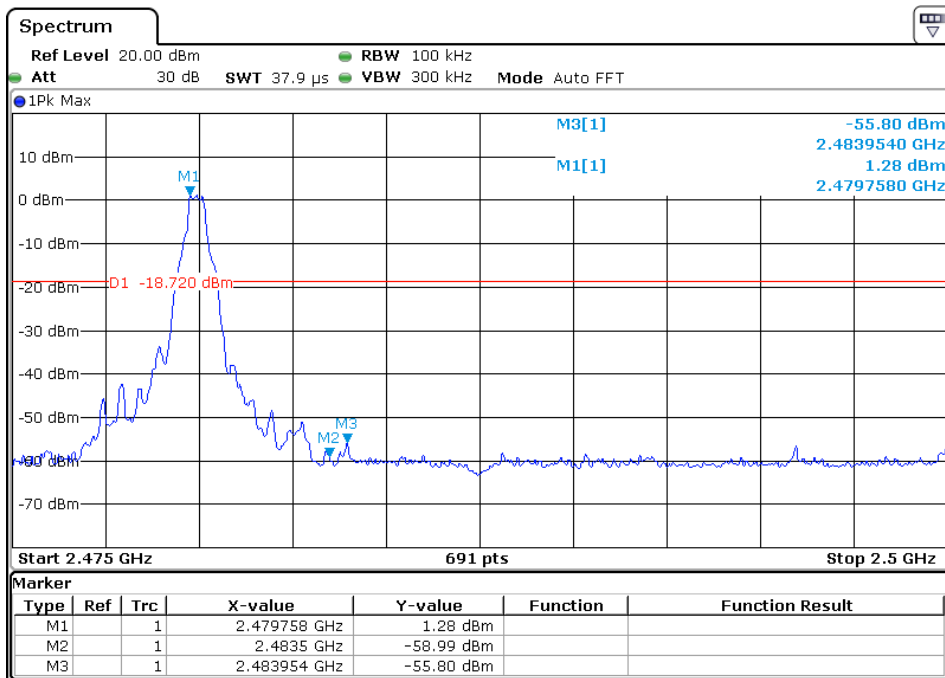

CH00 (Lower) Data rate 3Mbps

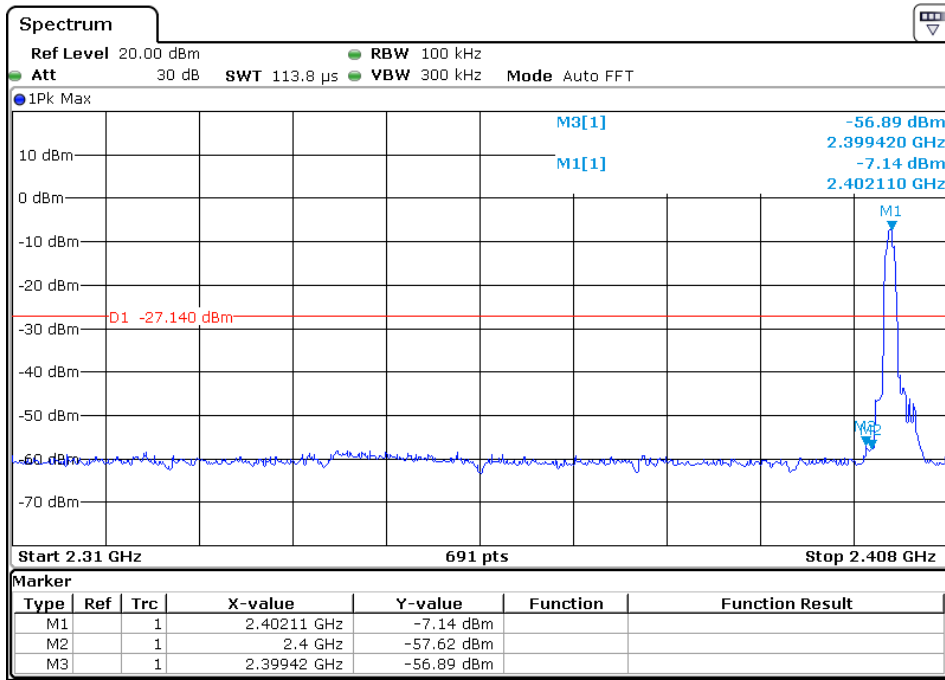

CH 78 (Upper) Data rate 3Mbps

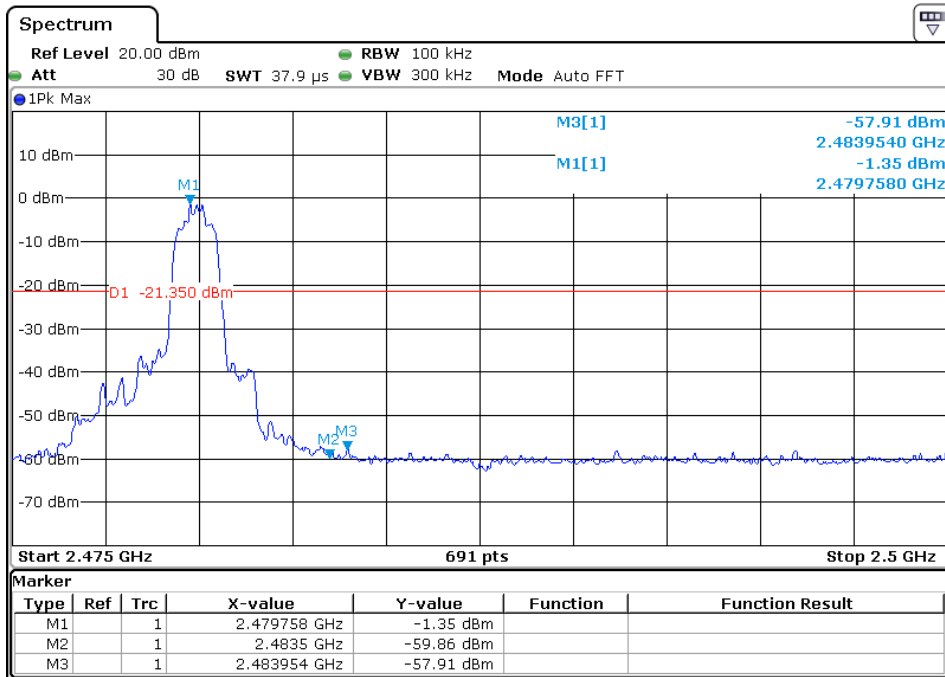

CH00 (Lower) Data rate 1Mbps

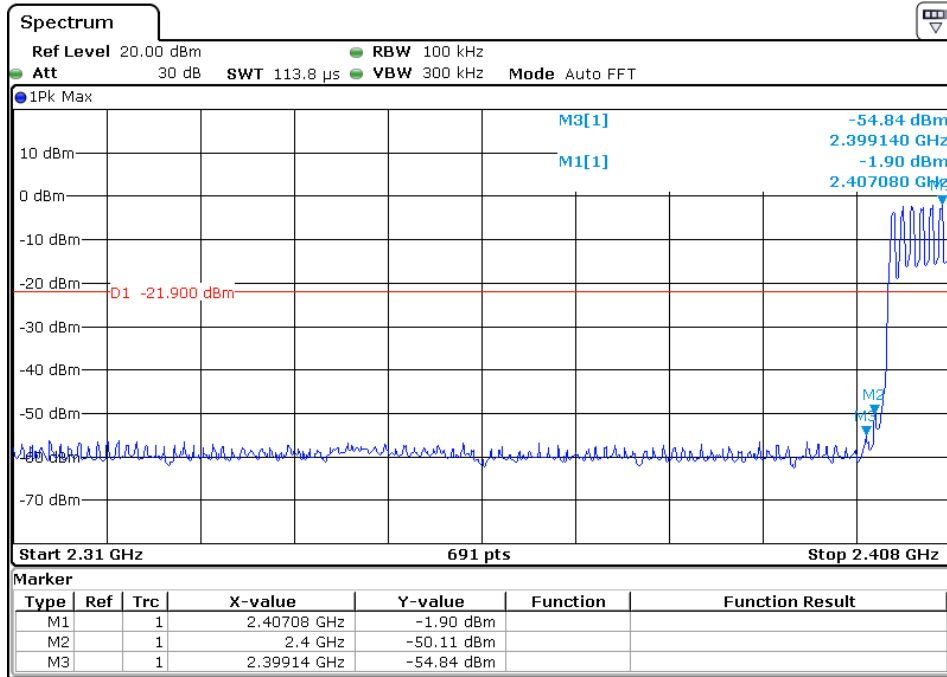

CH 78 (Upper) Data rate 1Mbps

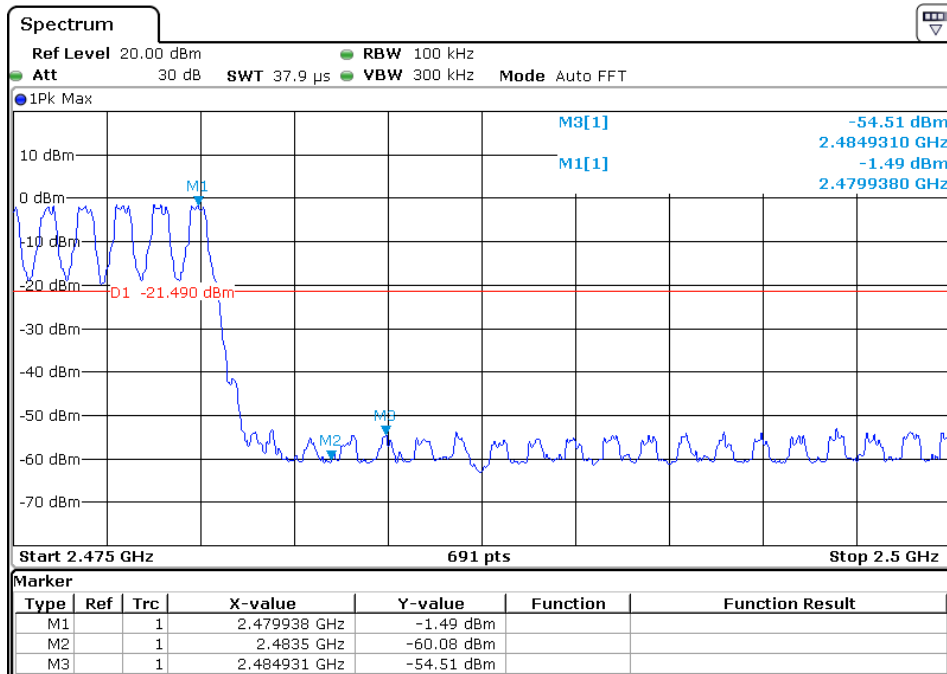

CH00 (Lower) Data rate 3Mbps

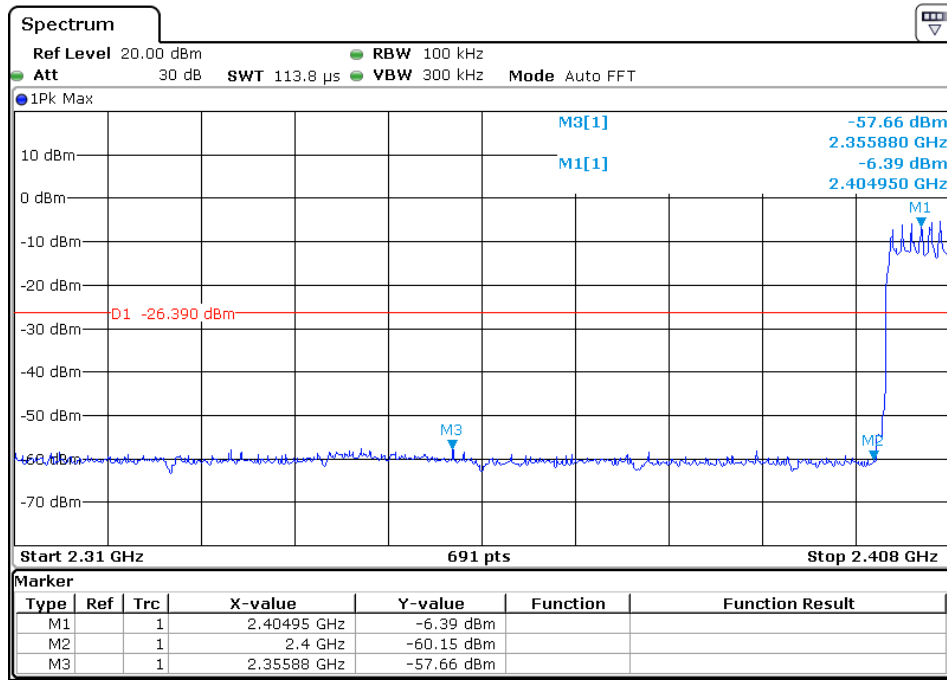

CH 78 (Upper) Data rate 3Mbps

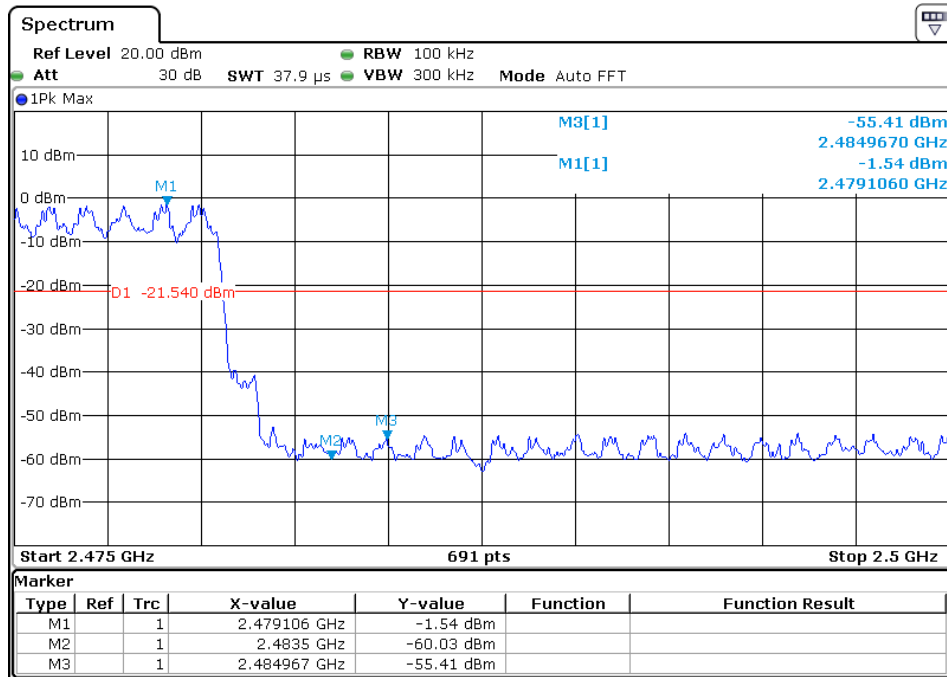

5.10 Conducted Spurious Emissions

5.10.1 Applied procedures / Limit

15.247(d) In any 100 kHz bandwidth outside the frequency band in which the spread spectrum or digitally modulated intentional radiator is operating, the radio frequency power that is produced by the intentional radiator shall be at least 20 dB below that in the 100 kHz bandwidth within the band that contains the highest level of the desired power, based on either an RF conducted or a radiated measurement, provided the transmitter demonstrates compliance with the peak conducted power limits. If the transmitter complies with the conducted power limits based on the use of RMS averaging over a time interval, as permitted under paragraph (b)(3) of this section, the attenuation required under this paragraph shall be 30 dB instead of 20 dB. Attenuation below the general limits specified in Section 15.209(a) is not required. In addition, radiated emissions which fall in the restricted bands, as defined in Section 15.205(a), must also comply with the radiated emission limits specified in Section 15.209(a) (see Section 15.205(c)).

5.10.2 Test procedure

- a. The EUT was directly connected to the spectrum analyzer and antenna output port as show in the block diagram below.
- b. Span = wide enough to capture the peak level of the in-band emission and all spurious emissions (e.g., harmonics) from the lowest frequency generated in the EUT up through the 10th harmonic. Typically, several plots are required to cover this entire span. RBW = 100 kHz
VBW ≥ RBW, Sweep = auto, Detector function = peak, Trace = max hold
sweep points ≥ investigated frequency range/RBW.

5.10.3 Deviation from standard

No deviation.

5.10.4 Test setup



5.10.5 Test results

CH00 Data rate 1Mbps

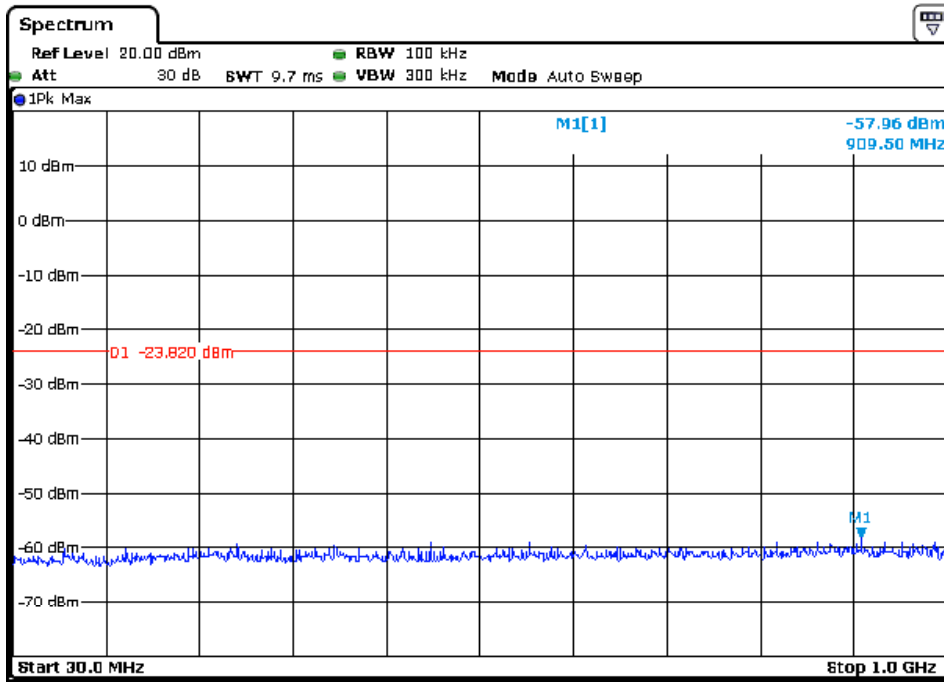

Note: Sweep Points=9700
CH00 Data rate 1Mbps

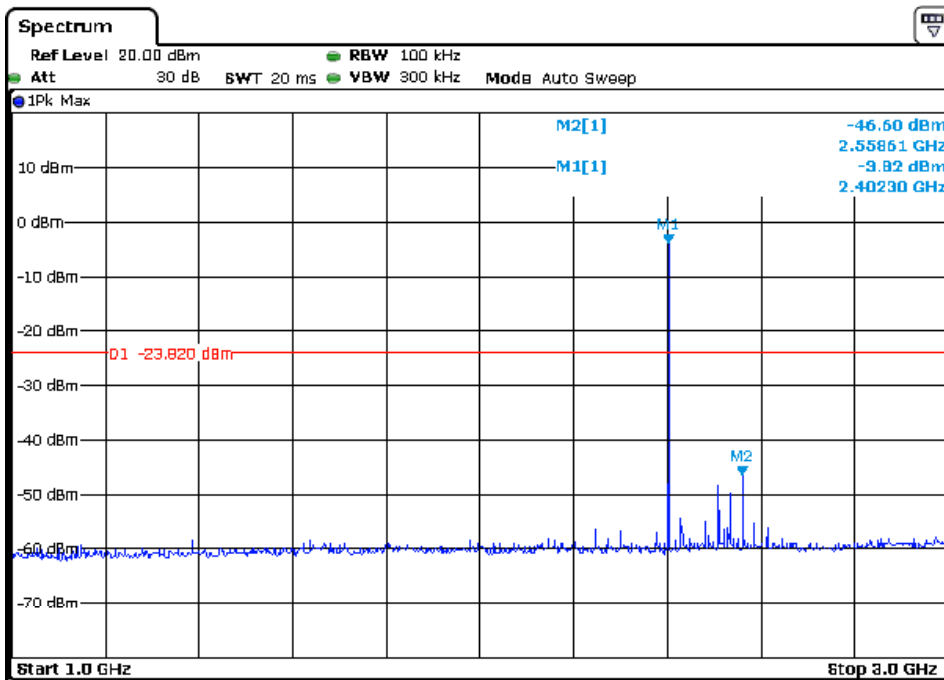

Note: Sweep Points=20000

CH00 Data rate 1Mbps

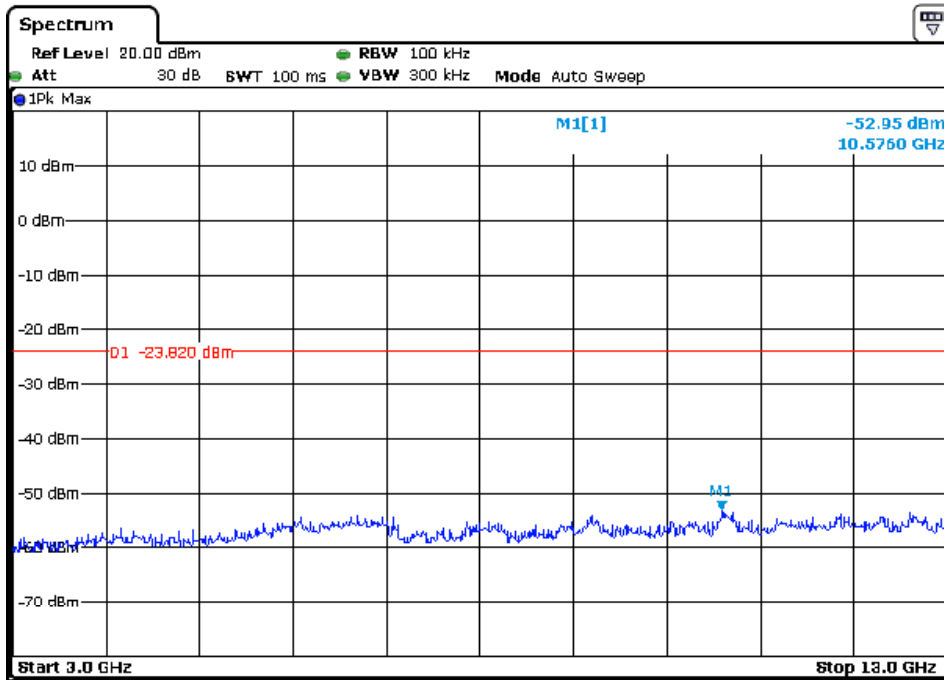

Note: Sweep Points=100000

CH00 Data rate 1Mbps

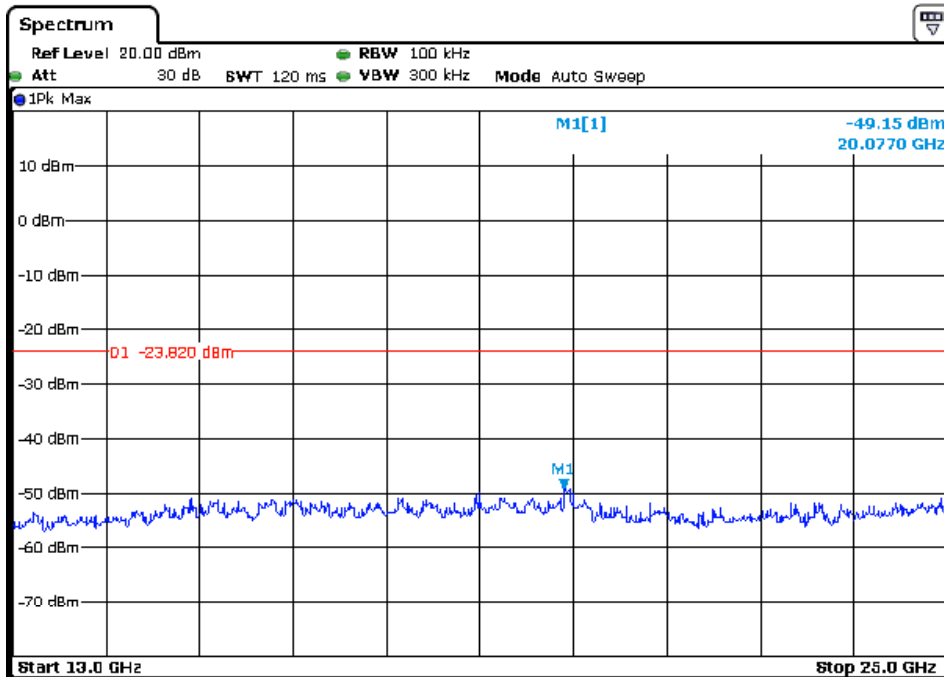

Note: Sweep Points=120000

CH39 Data rate 1Mbps

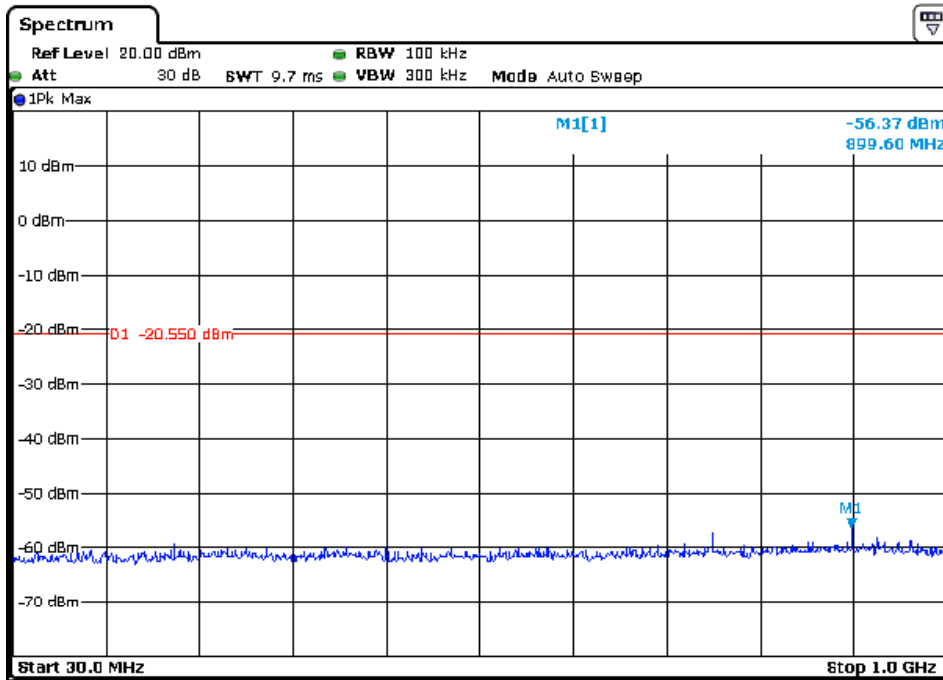

Note: Sweep Points=9700

CH39 Data rate 1Mbps

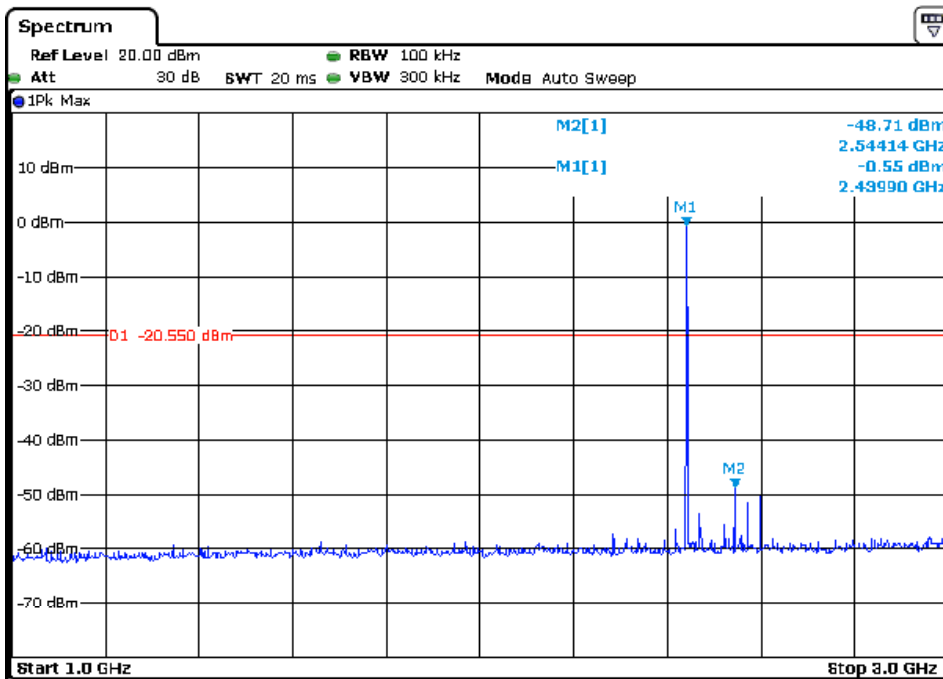

Note: Sweep Points=20000

CH39 Data rate 1Mbps

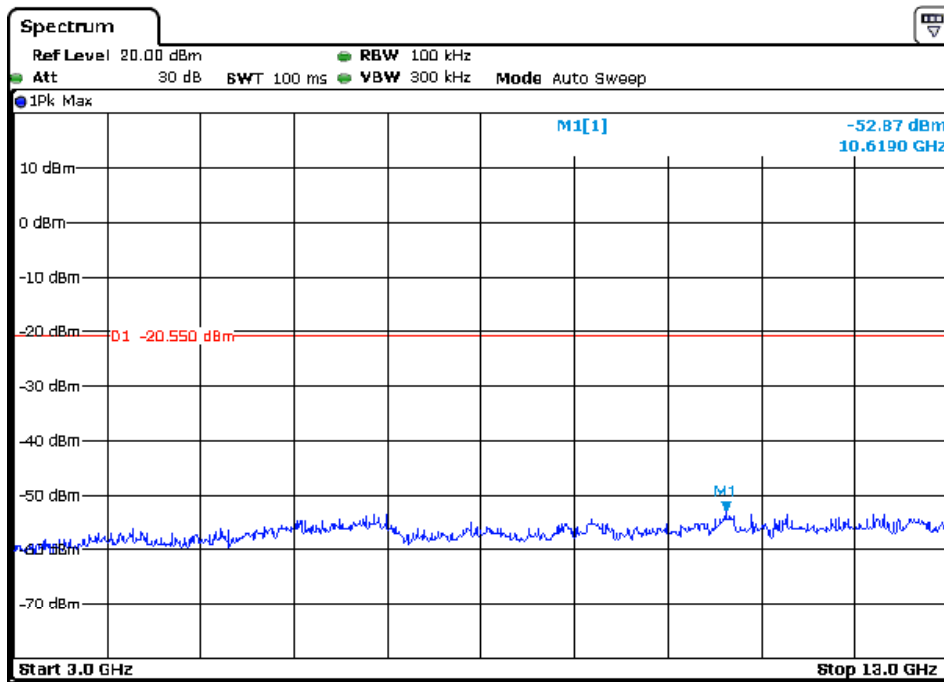

Note: Sweep Points=100000

CH39 Data rate 1Mbps

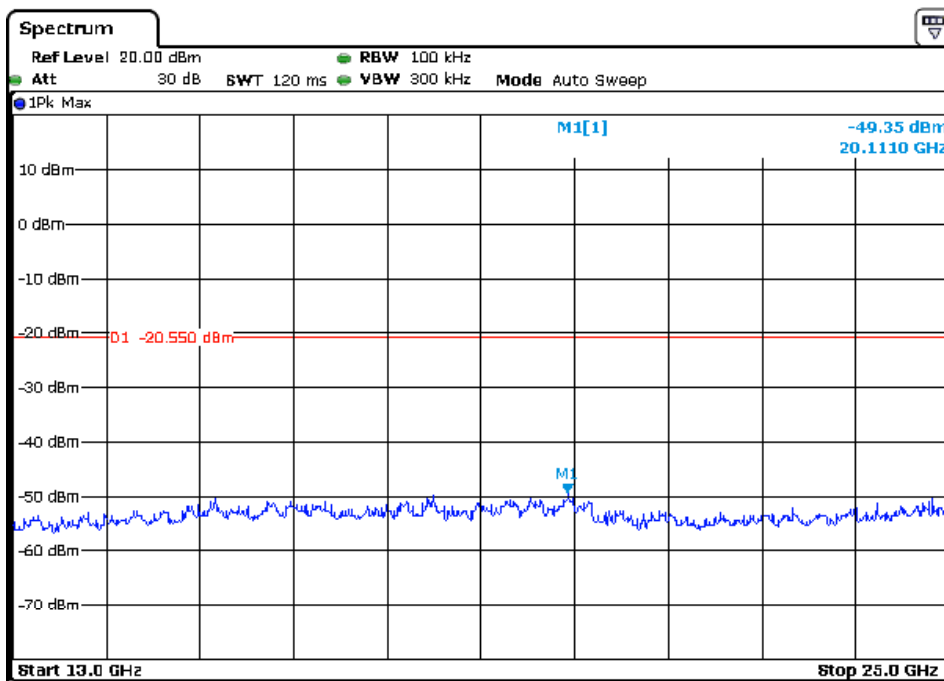

Note: Sweep Points=120000

CH78 Data rate 1Mbps

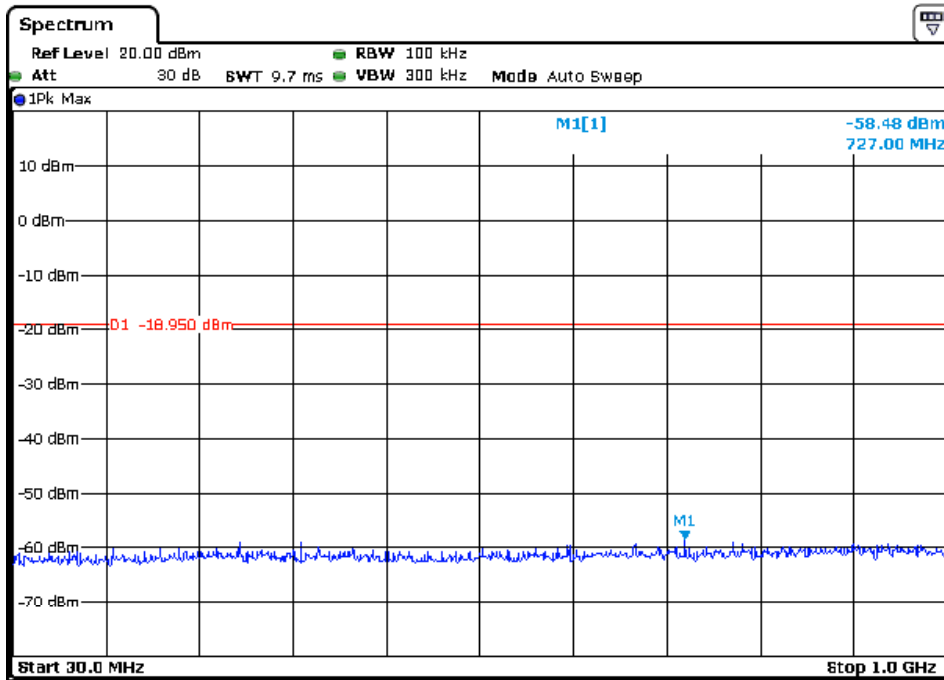

Note: Sweep Points=9700

CH78 Data rate 1Mbps

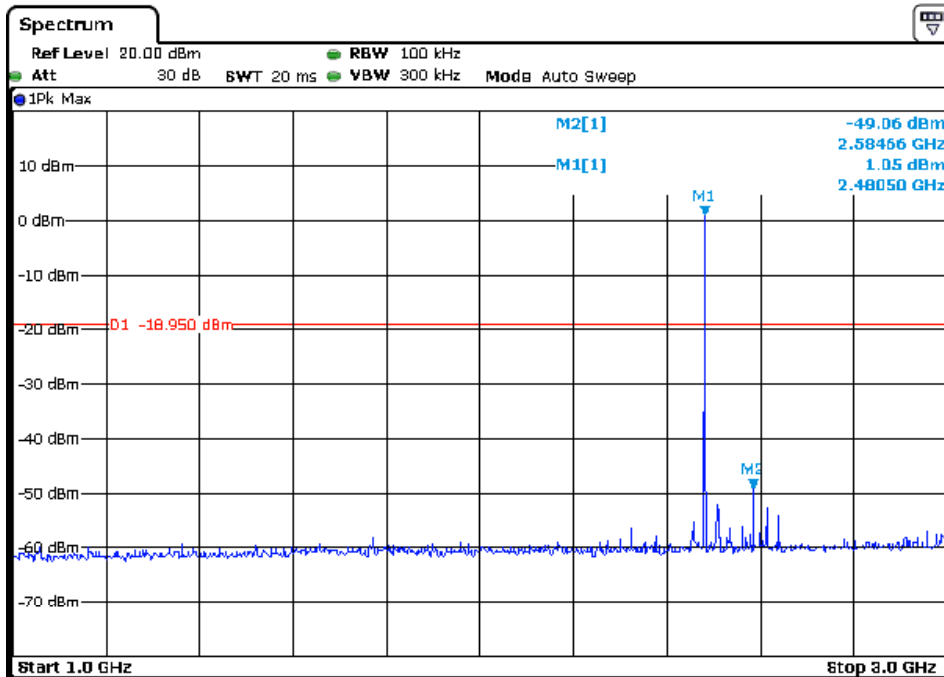

Note: Sweep Points=20000

CH78 Data rate 1Mbps

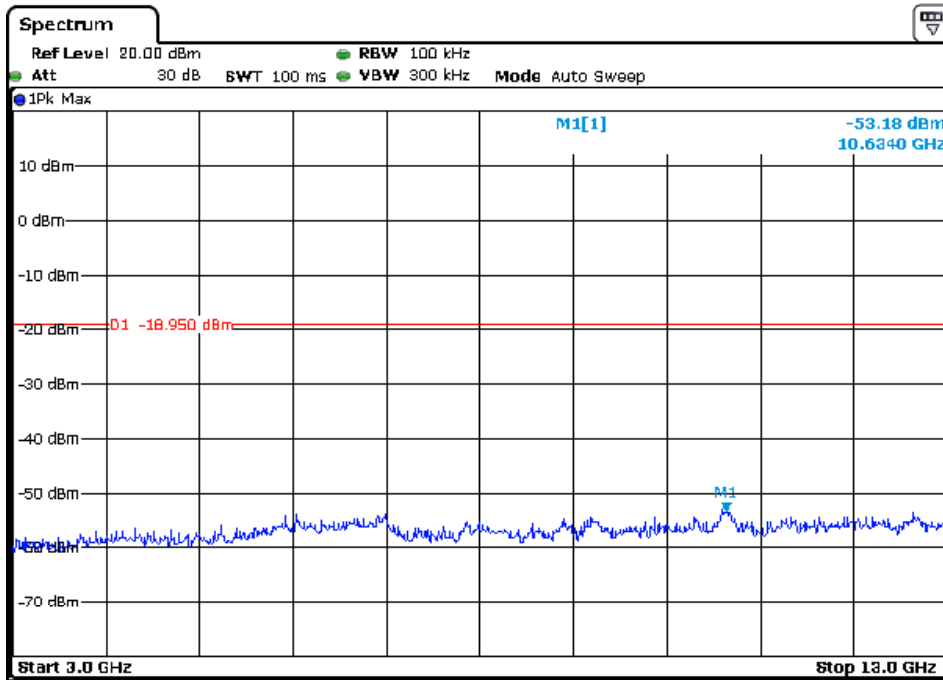

Note: Sweep Points=100000

CH78 Data rate 1Mbps

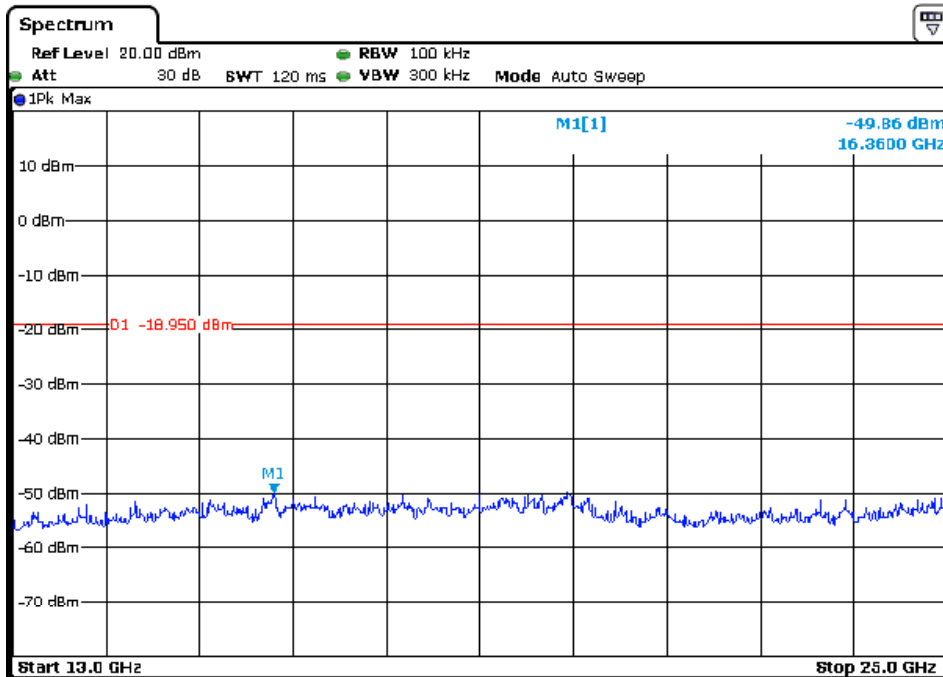

Note: Sweep Points=120000

CH00 Data rate 3Mbps

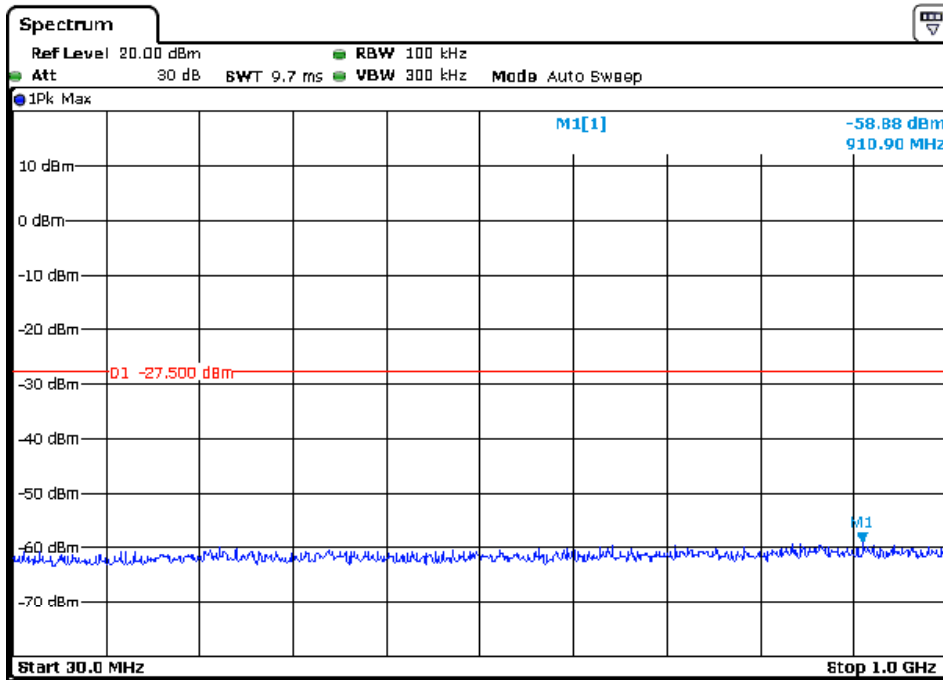

Note: Sweep Points=9700

CH00 Data rate 3Mbps

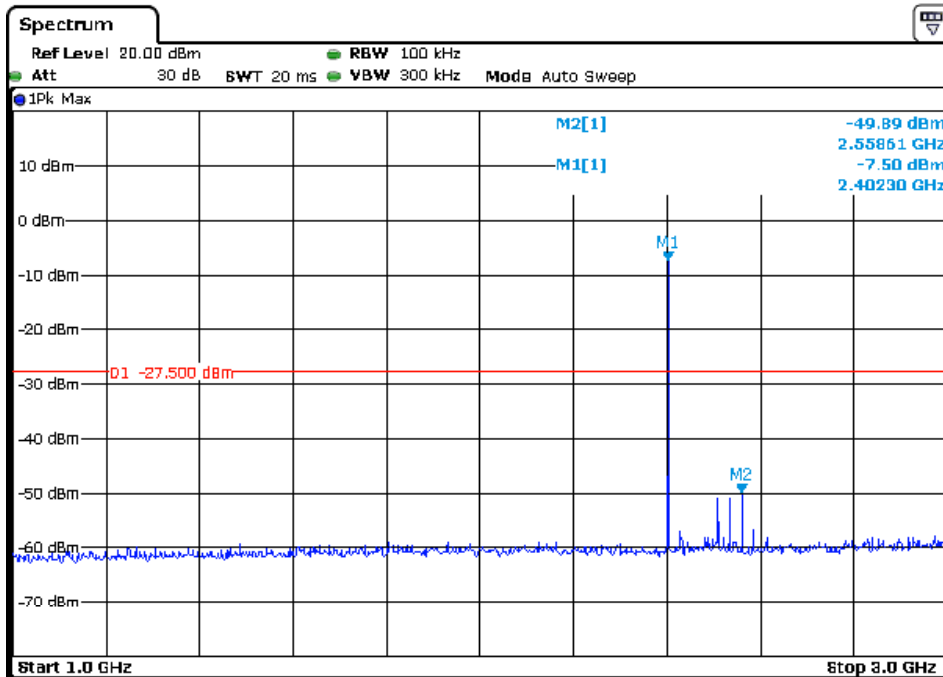

Note: Sweep Points=20000

CH00 Data rate 3Mbps

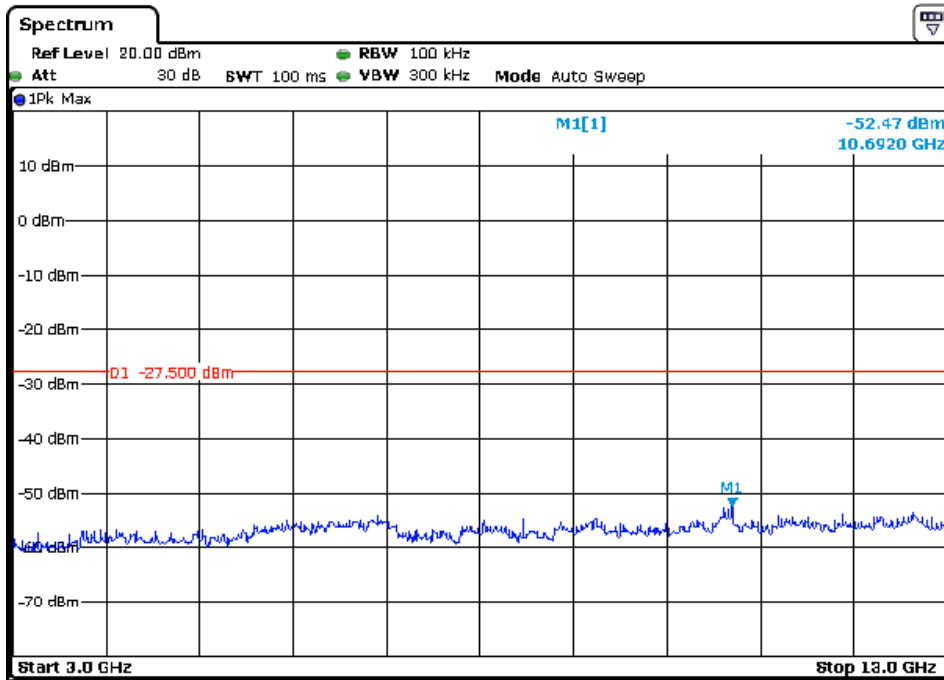

Note: Sweep Points=100000

CH00 Data rate 3Mbps

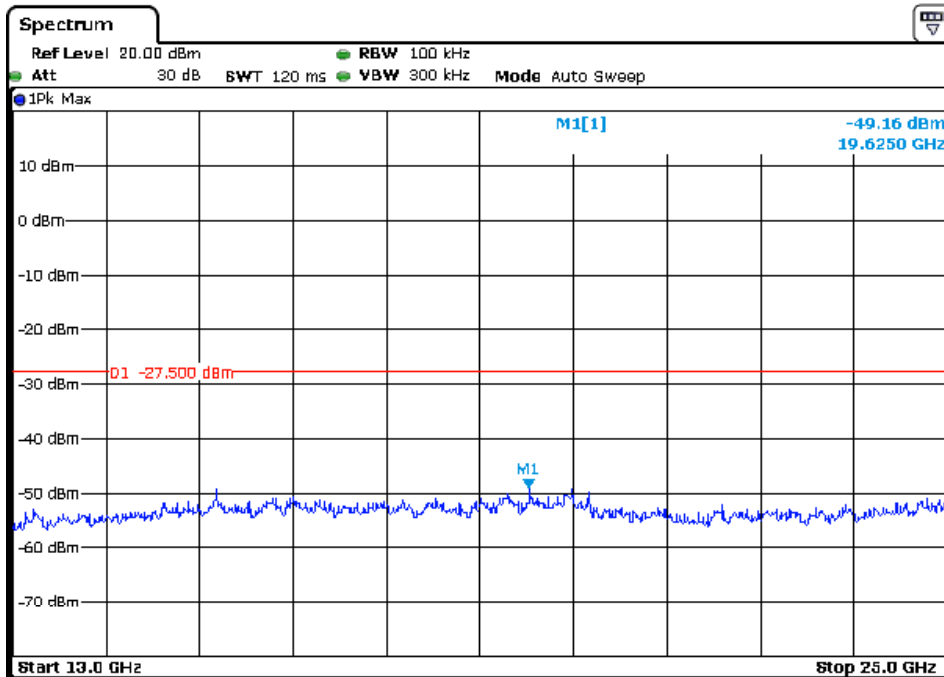

Note: Sweep Points=120000

CH39 Data rate 3Mbps

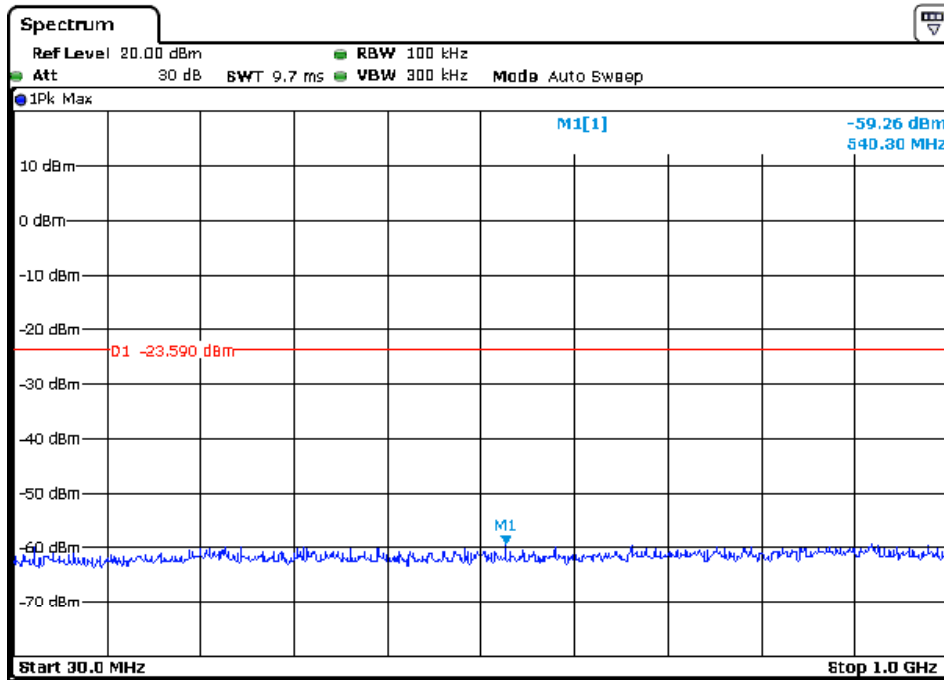

Note: Sweep Points=9700

CH39 Data rate 3Mbps

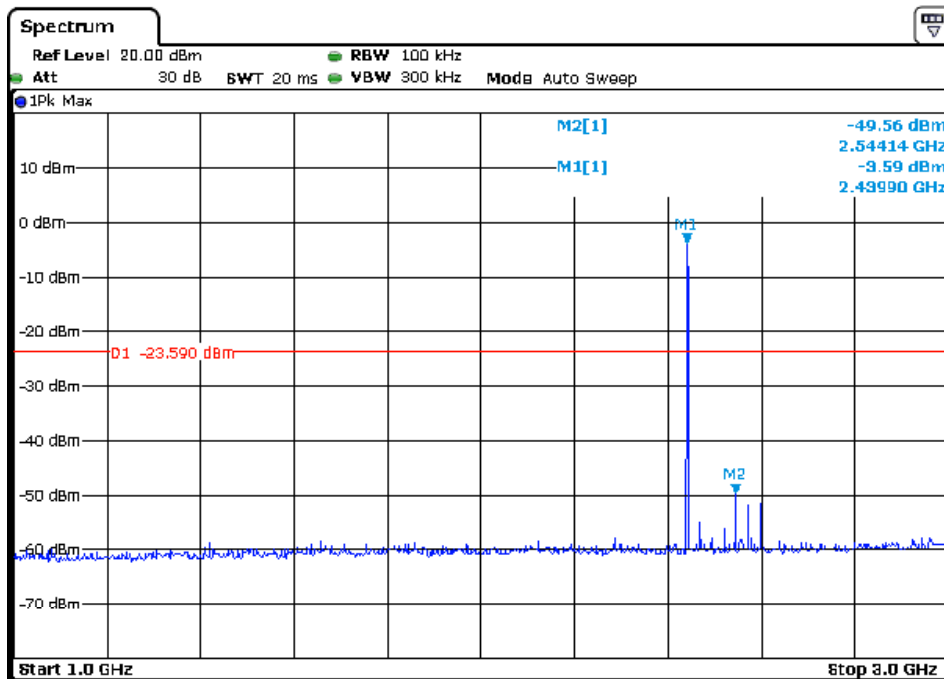

Note: Sweep Points=20000

CH39 Data rate 3Mbps

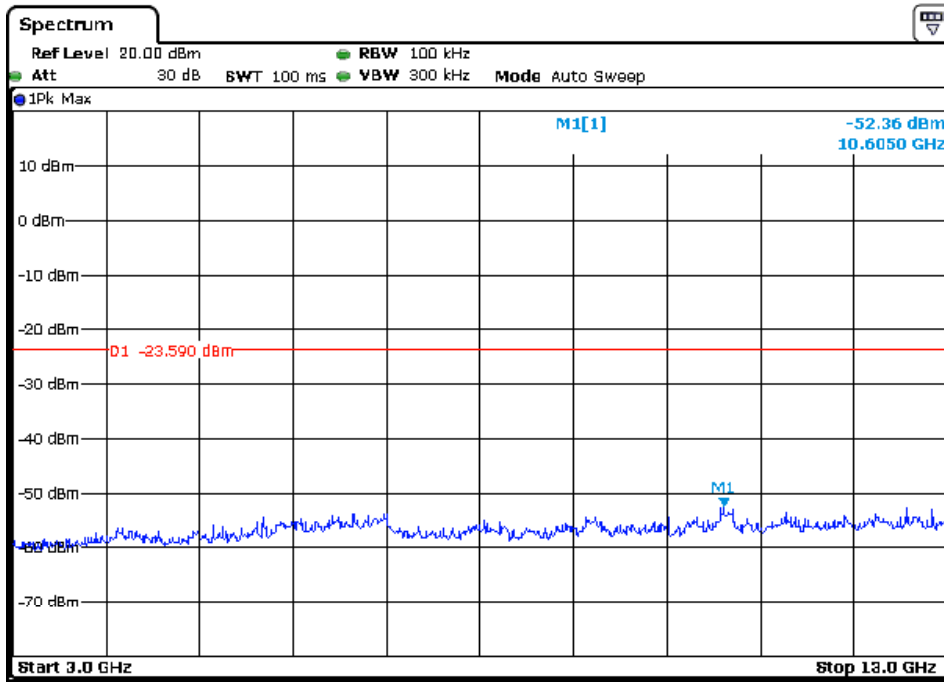

Note: Sweep Points=100000

CH39 Data rate 3Mbps

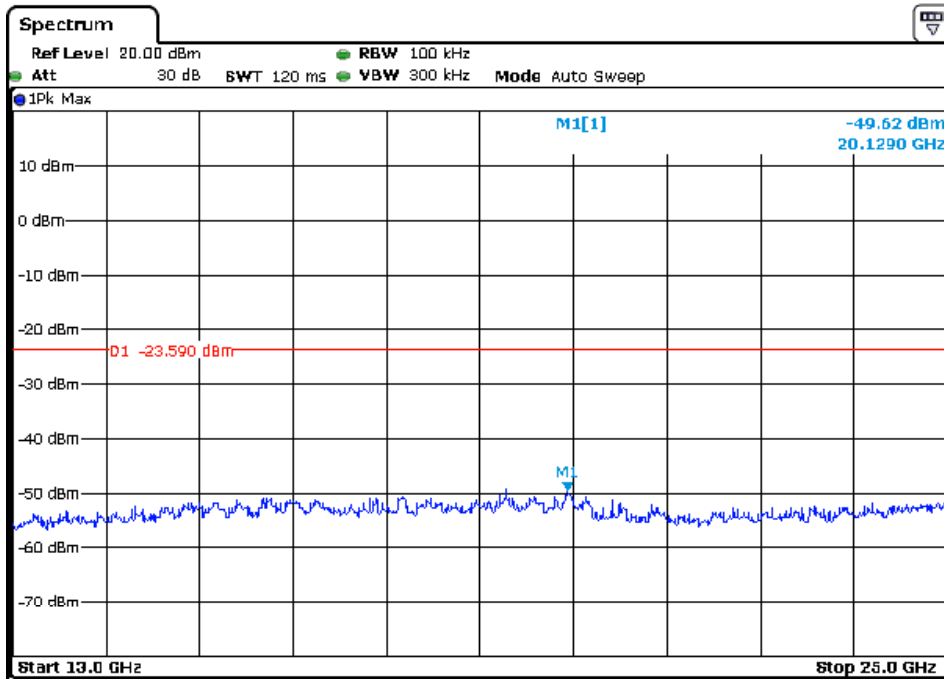

Note: Sweep Points=120000

CH78 Data rate 3Mbps

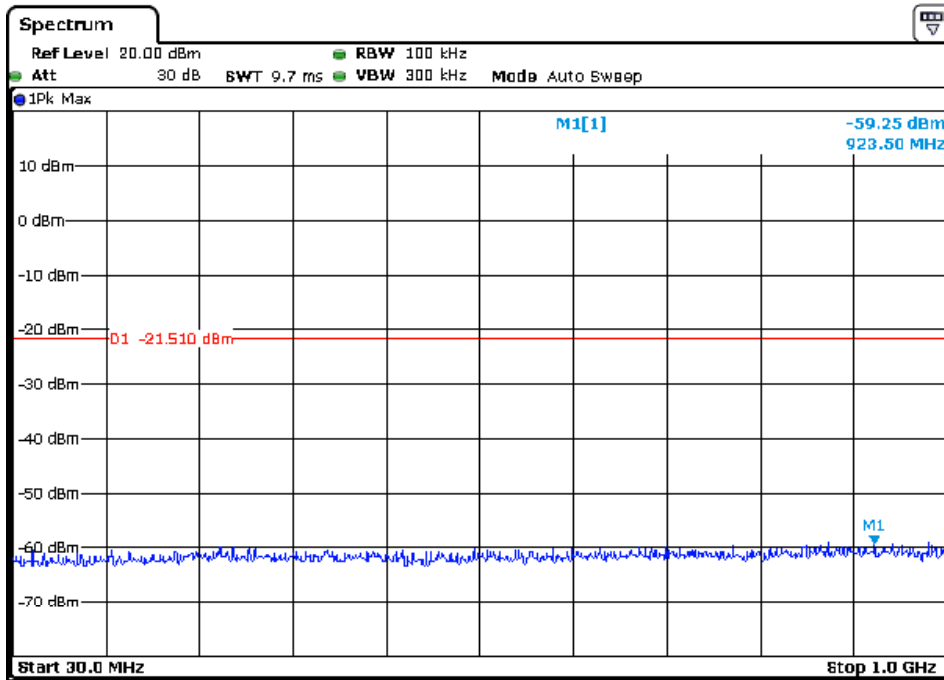

Note: Sweep Points=9700

CH78 Data rate 3Mbps

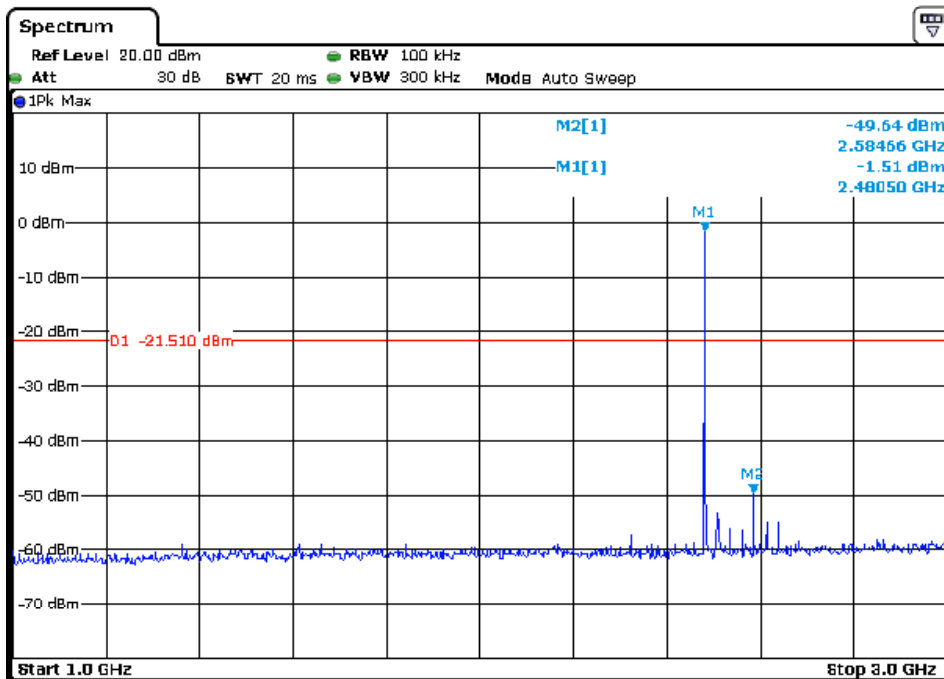

Note: Sweep Points=20000

CH78 Data rate 3Mbps

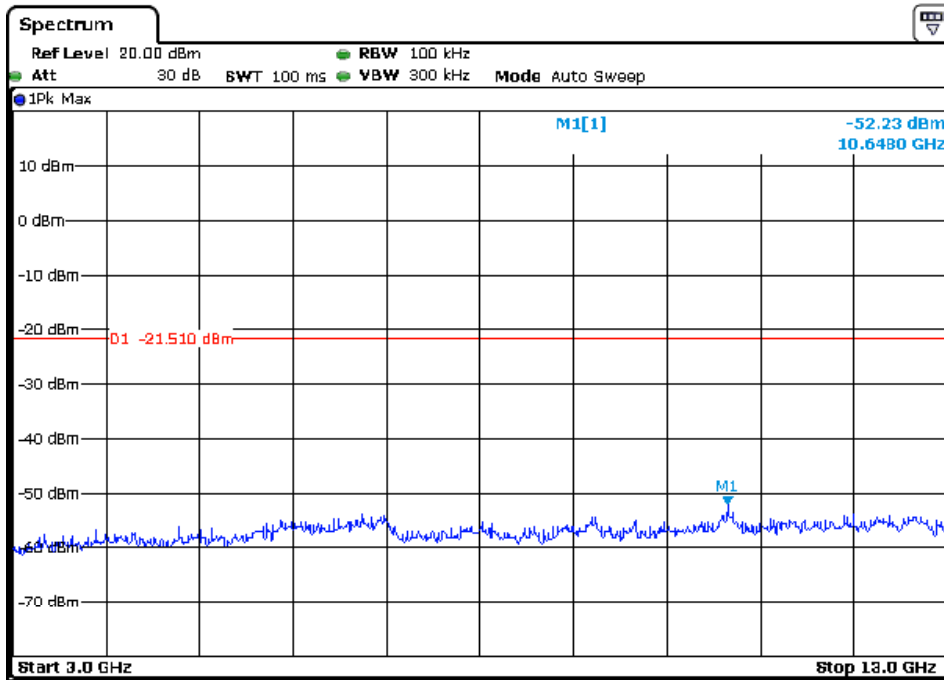

Note: Sweep Points=100000

CH78 Data rate 3Mbps

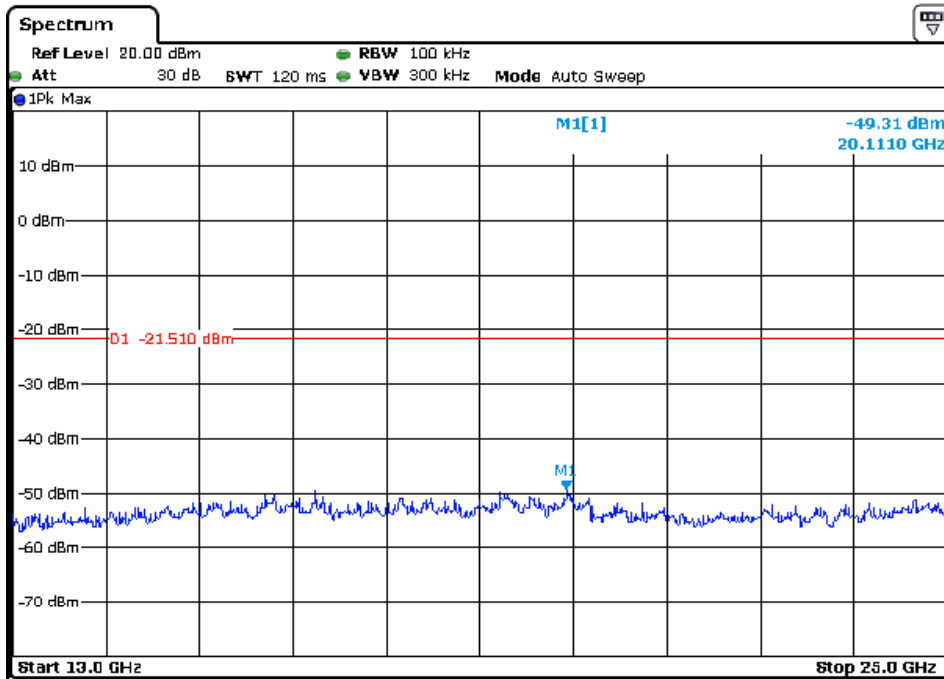

Note: Sweep Points=120000

6 Photographs

6.1 Radiated Spurious Emission Test Setup

Below 1GHz:

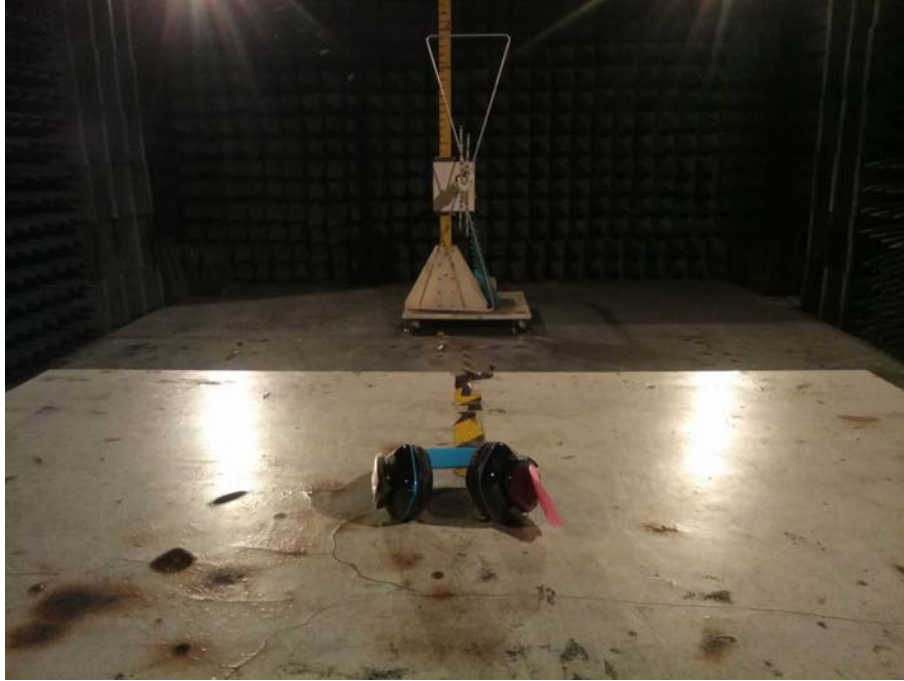

Above 1GHz:



6.2 Conducted Emission Test Setup



7 APPENDIX-Photographs of EUT Constructional Details













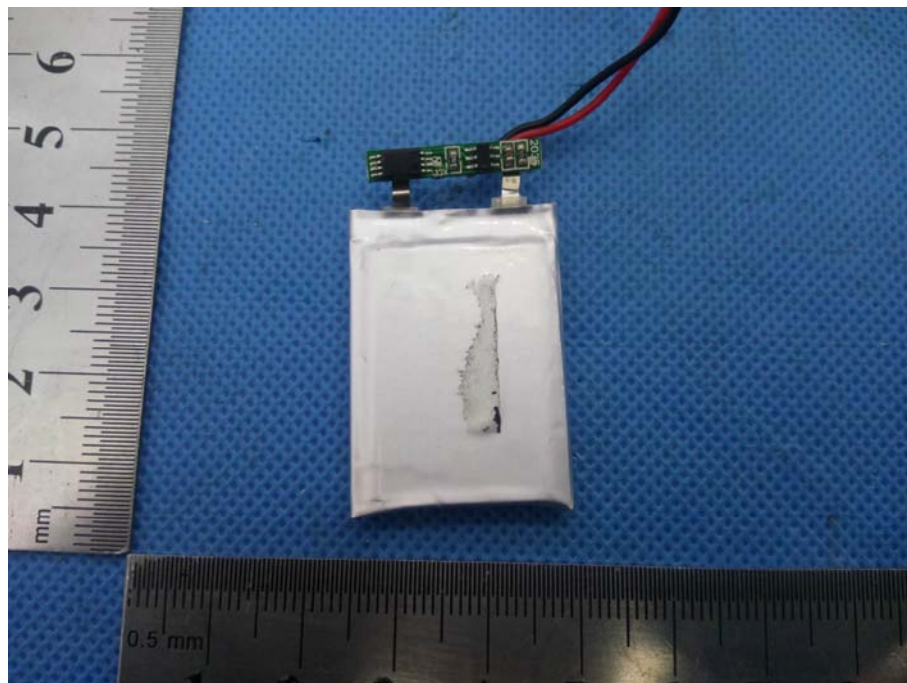

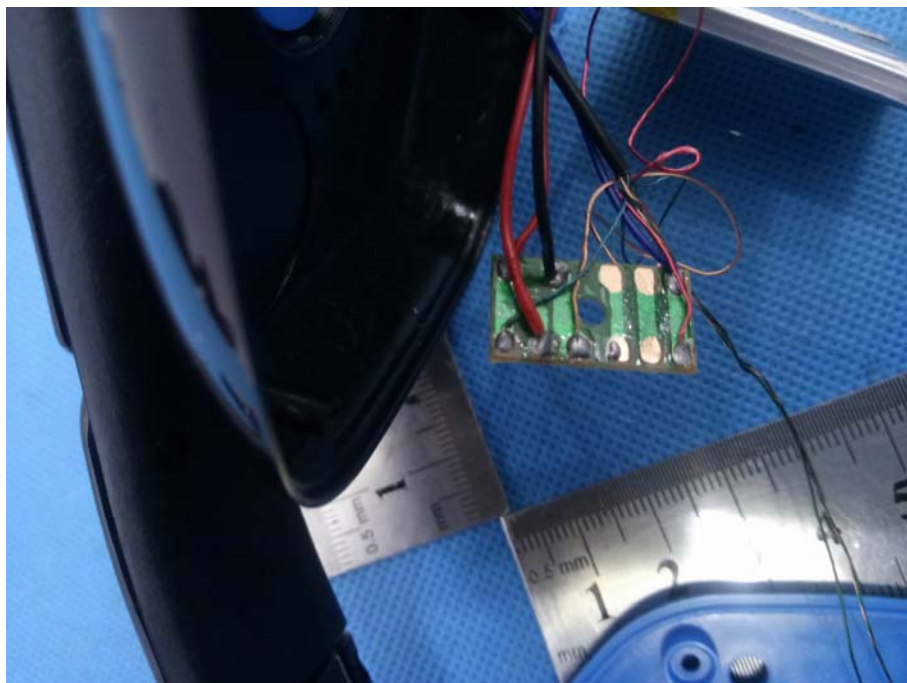
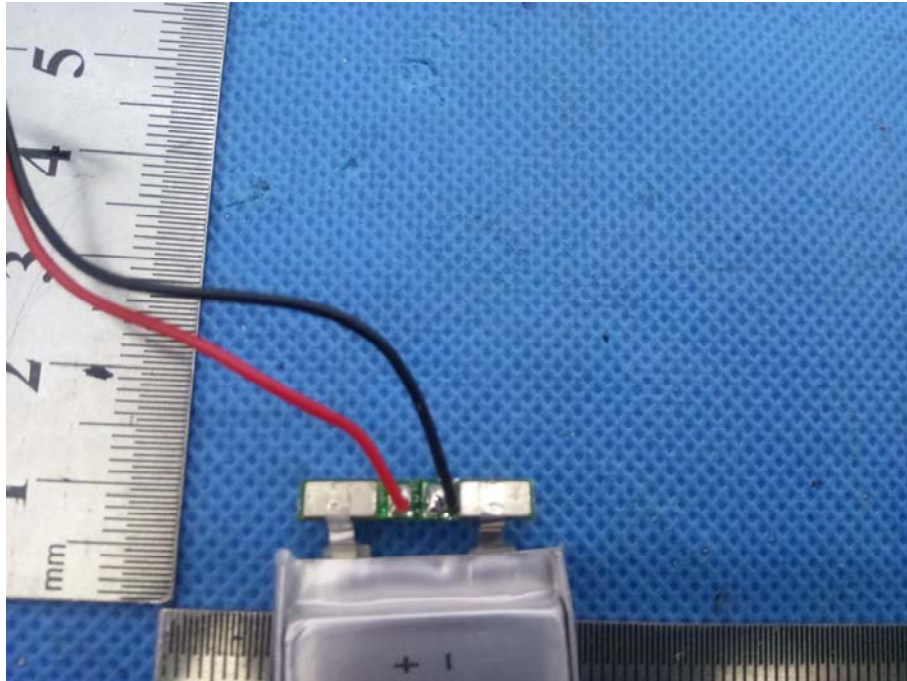

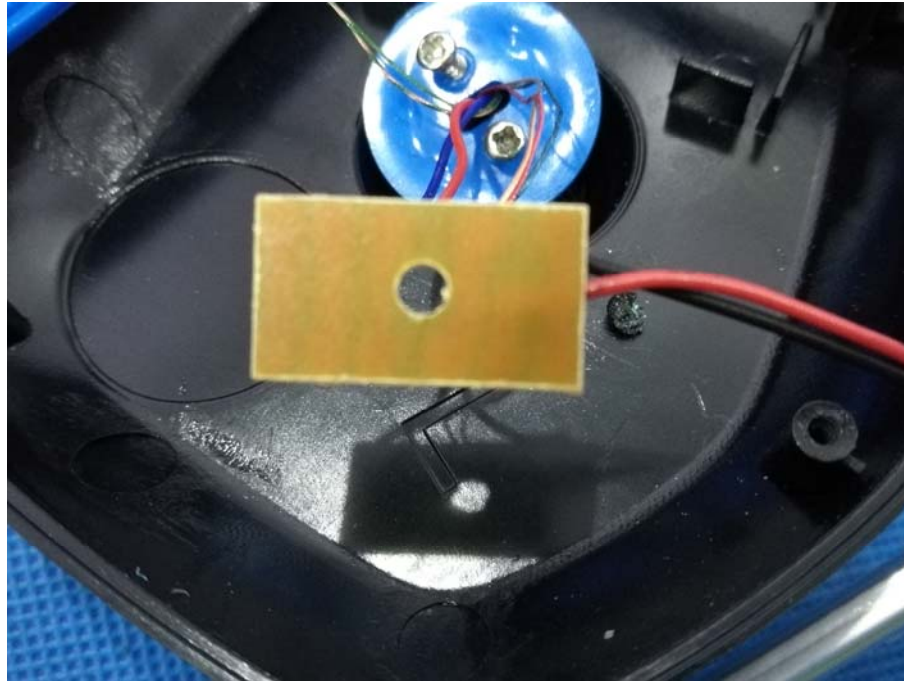

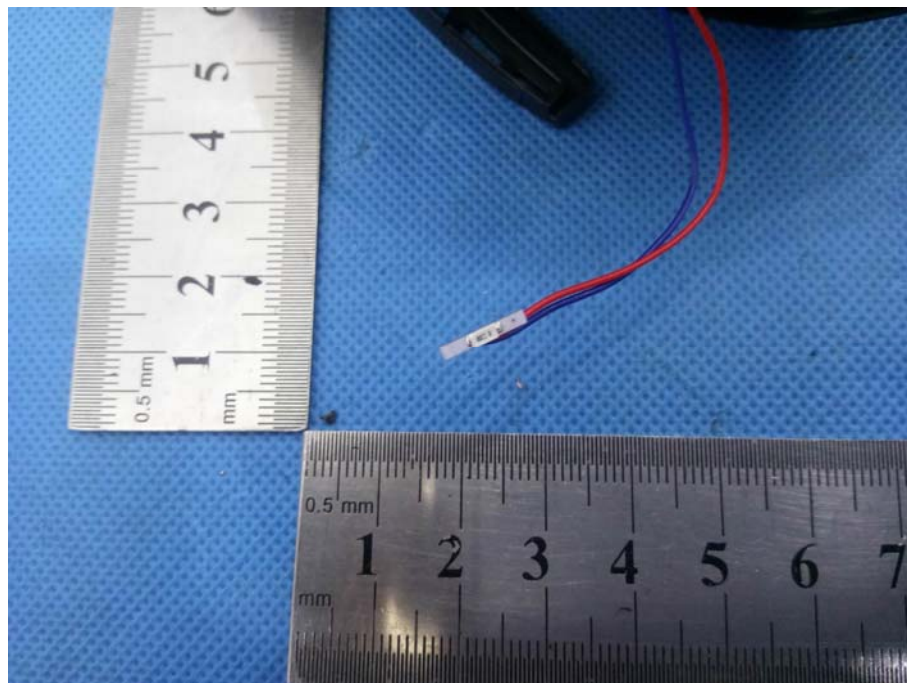

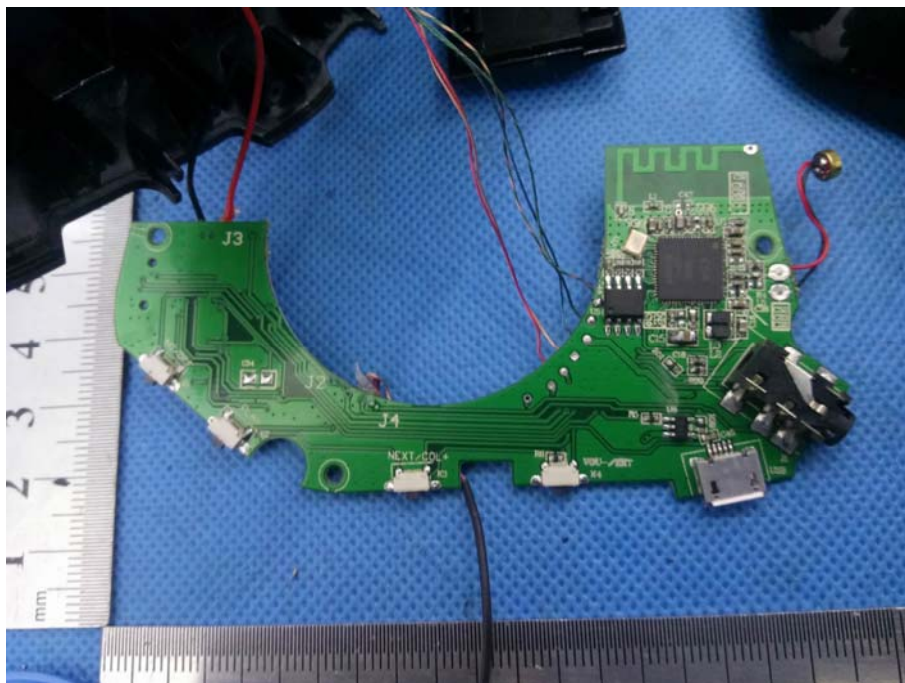
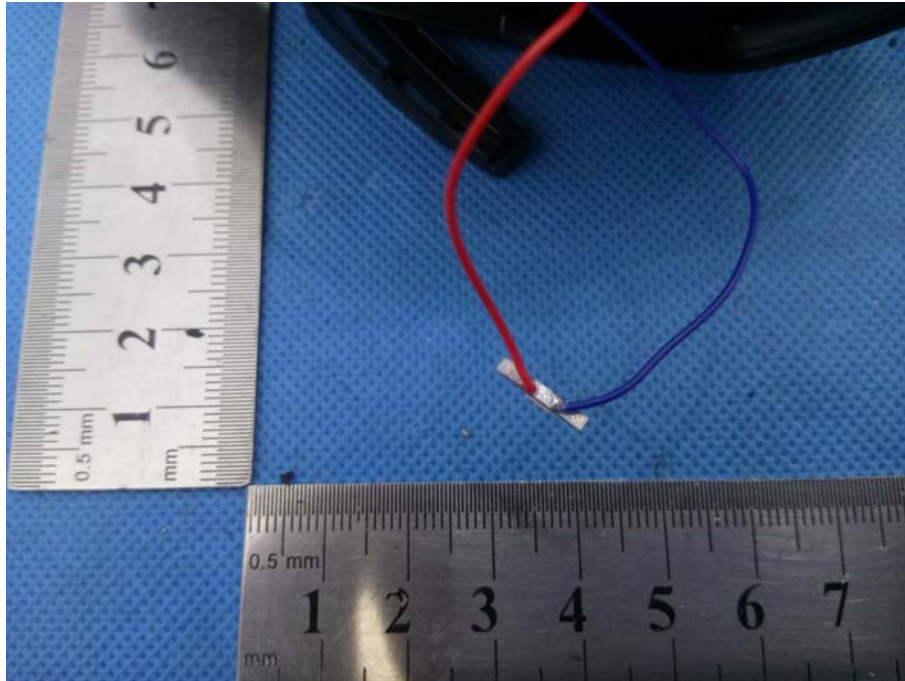

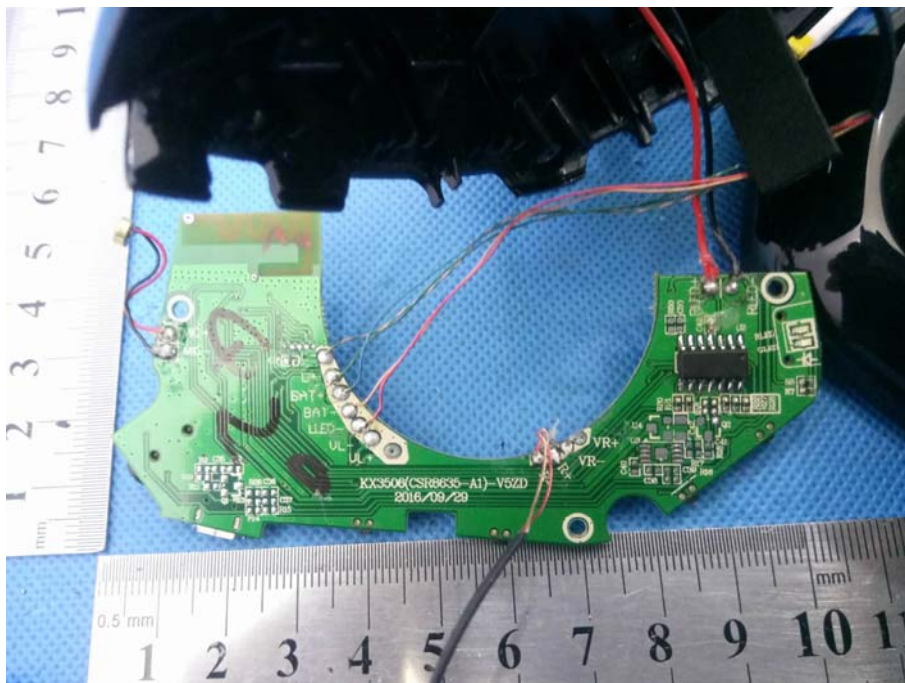
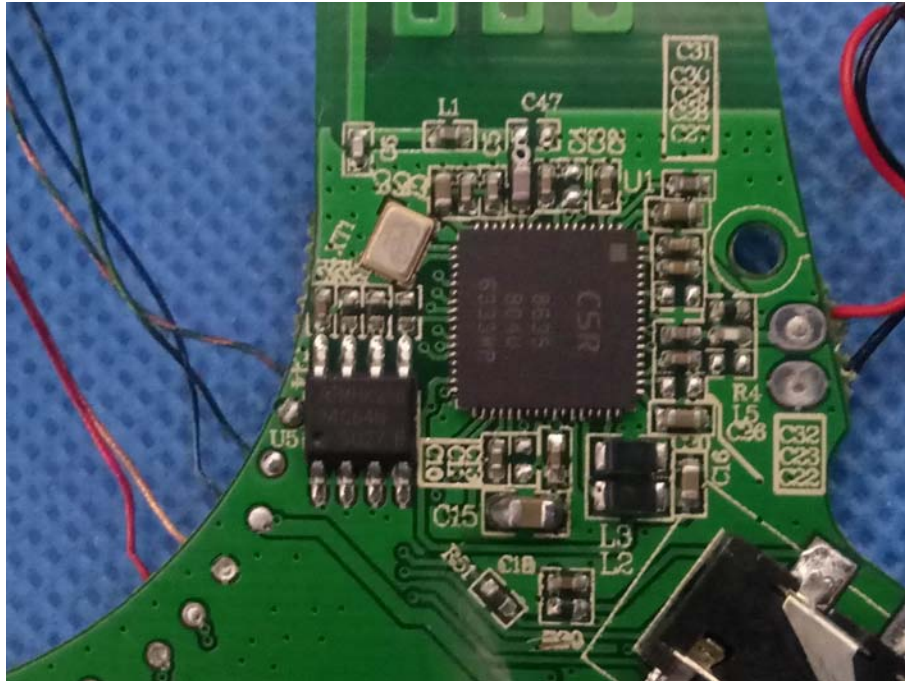

** End of report **