

Transmitter Conducted Emissions Masks (continued)

Results: 10 MHz / SF256 / Horizontal

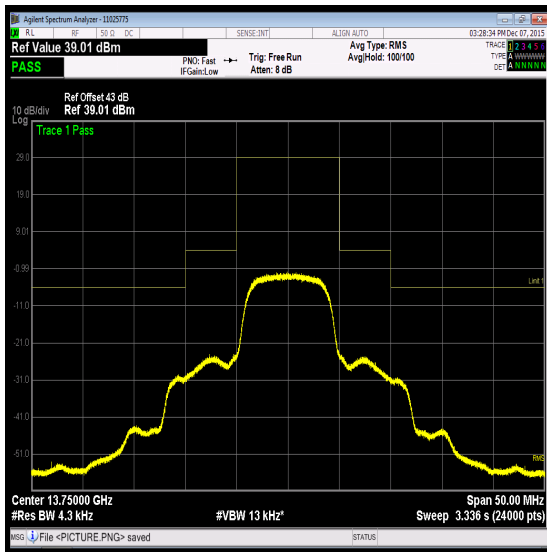

Bottom Channel

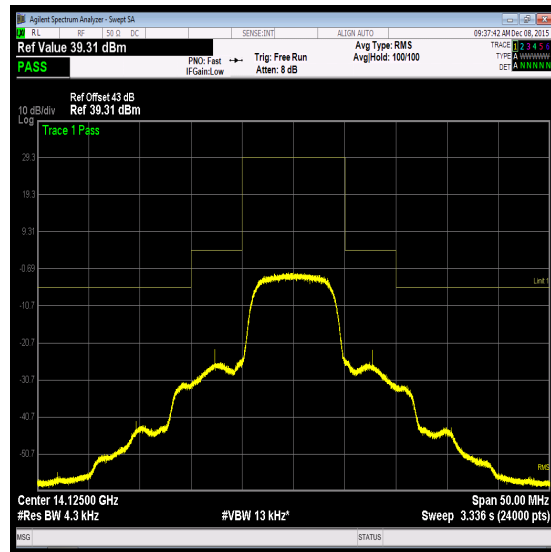

Middle Channel

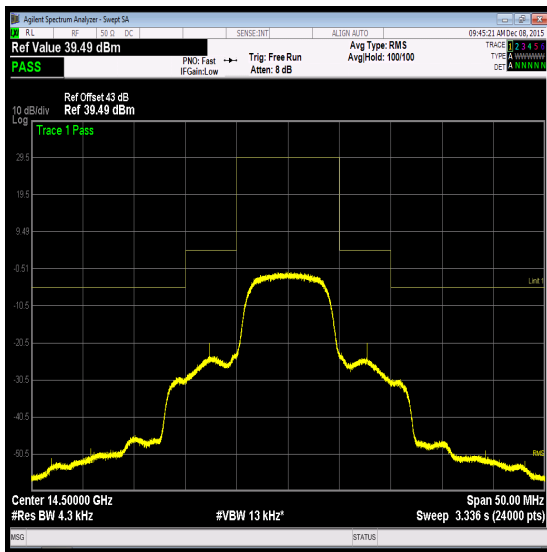

Top Channel

Transmitter Conducted Emissions Masks (continued)

Results: 10 MHz / SF128 / Vertical

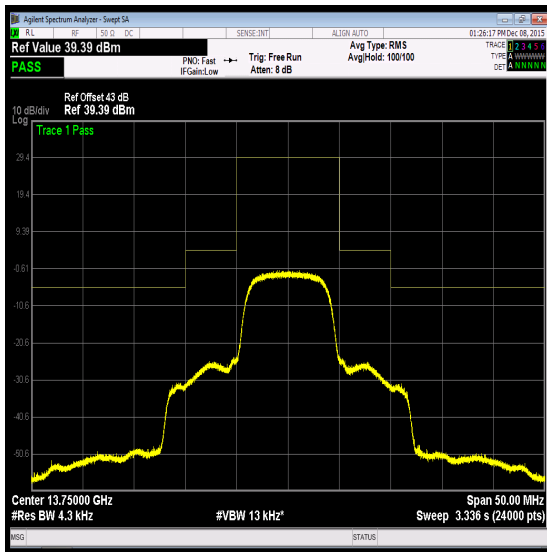

Bottom Channel

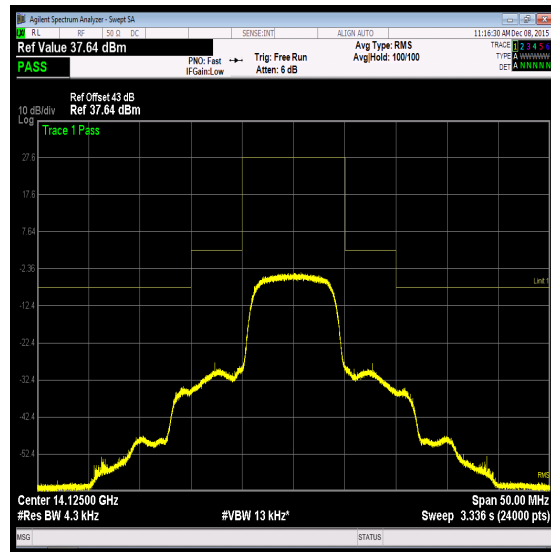

Middle Channel

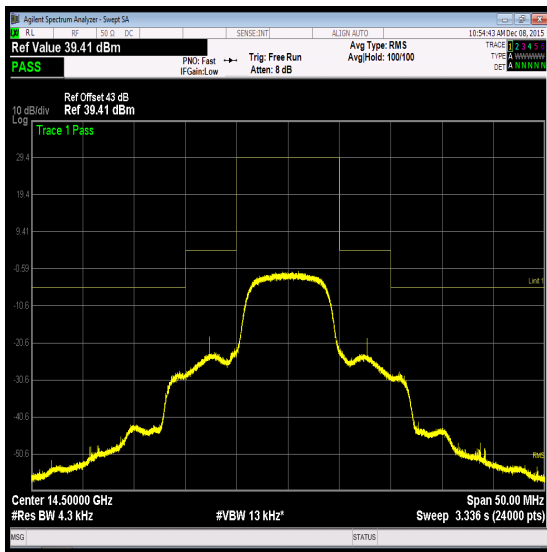

Top Channel

Transmitter Conducted Emissions Masks (continued)

Results: 10 MHz / SF128 / Horizontal

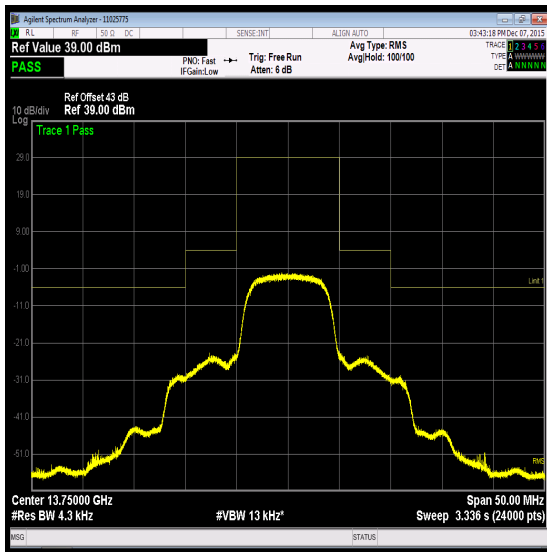

Bottom Channel

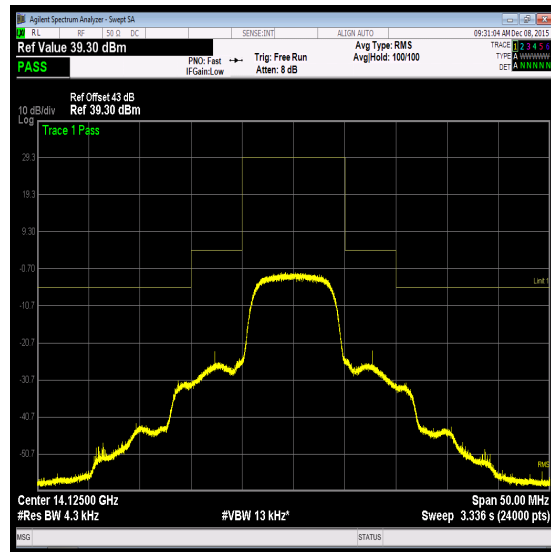

Middle Channel

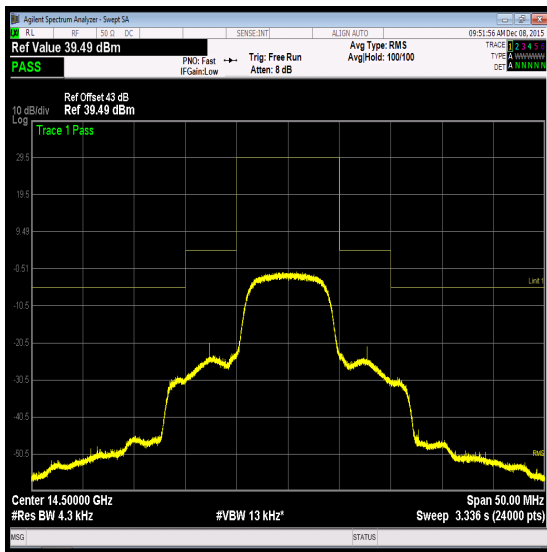

Top Channel

Transmitter Conducted Emissions Masks (continued)

Results: 10 MHz / SF64 / Vertical

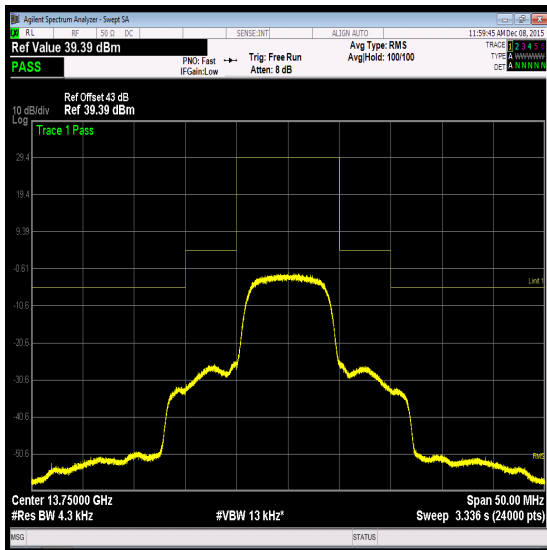

Bottom Channel

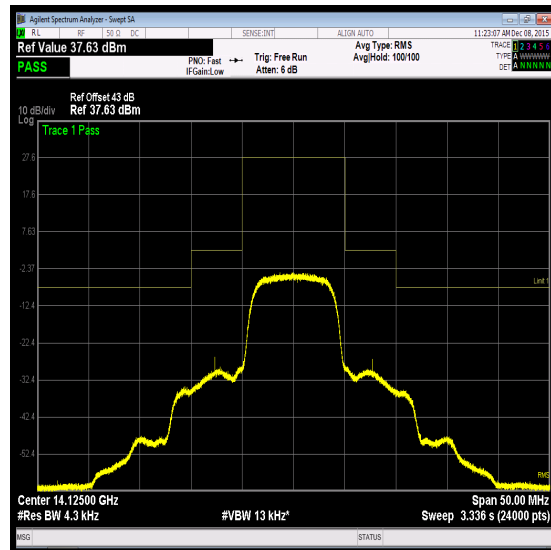

Middle Channel

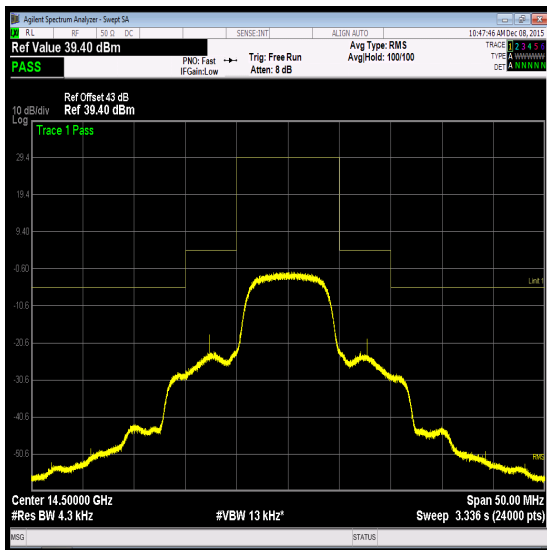

Top Channel

Transmitter Conducted Emissions Masks (continued)

Results: 10 MHz / SF64 / Horizontal

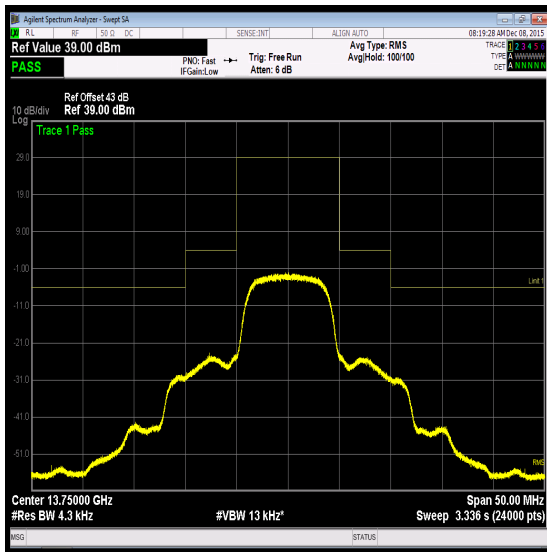

Bottom Channel

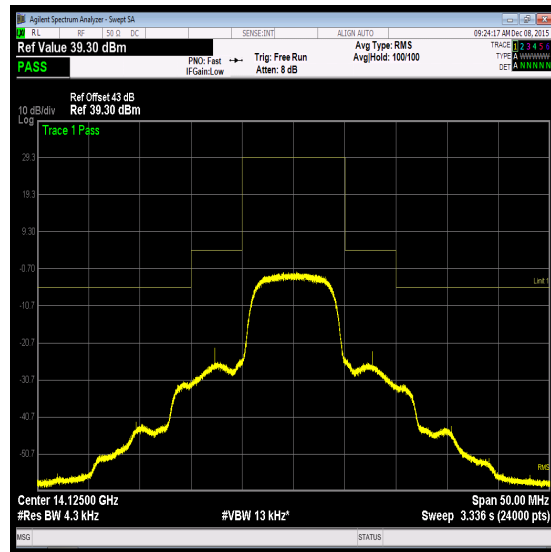

Middle Channel

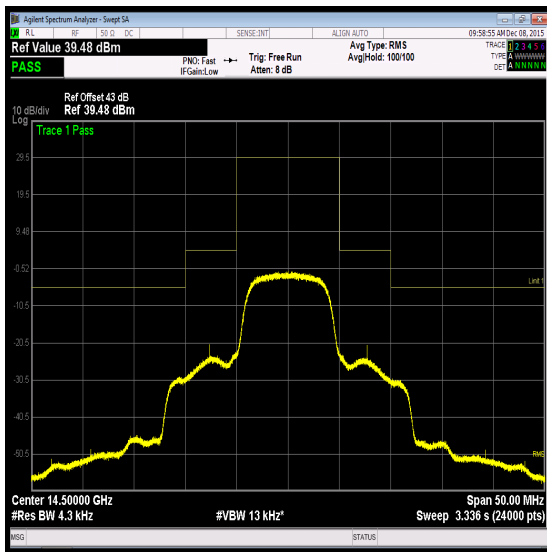

Top Channel

Transmitter Conducted Emissions Masks (continued)

Results: 10 MHz / SF32 / Vertical

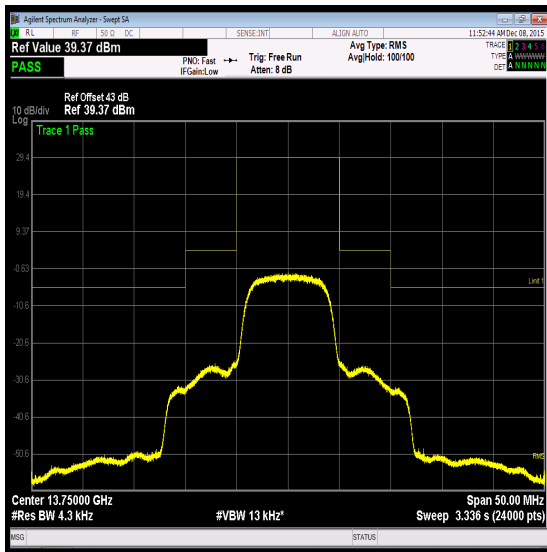

Bottom Channel

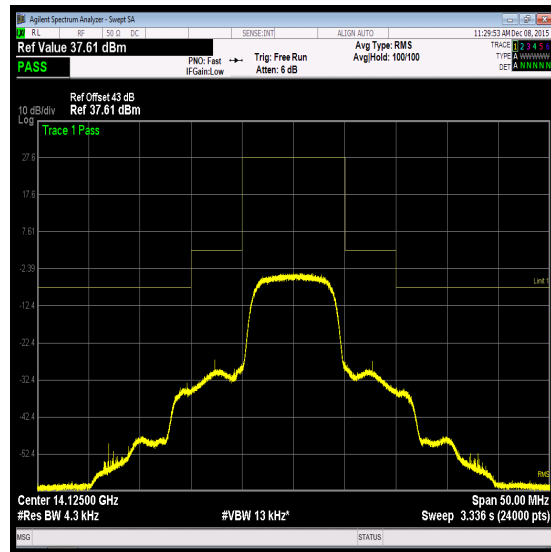

Middle Channel

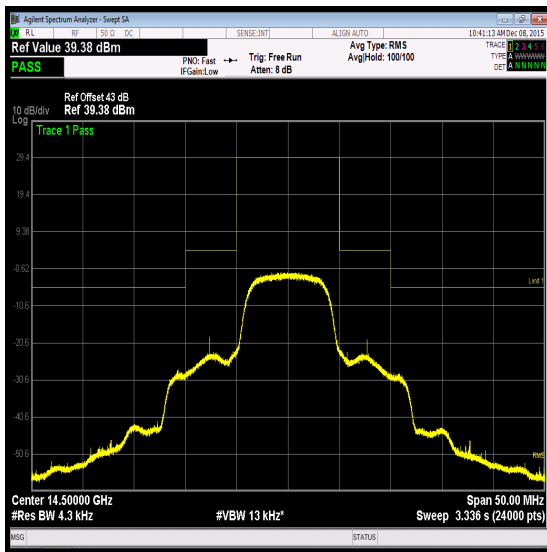

Top Channel

Transmitter Conducted Emissions Masks (continued)

Results: 10 MHz / SF32 / Horizontal

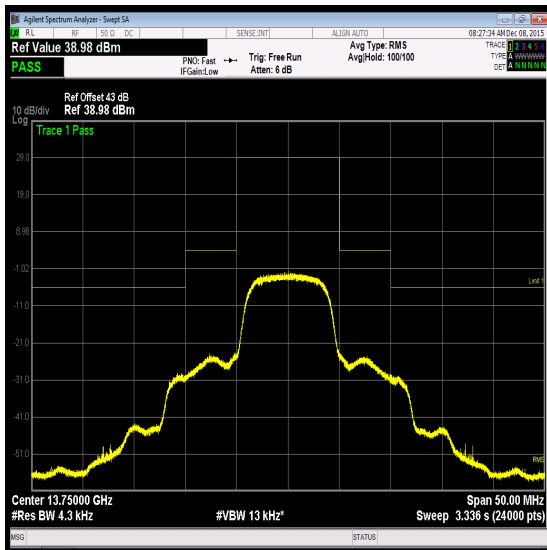

Bottom Channel

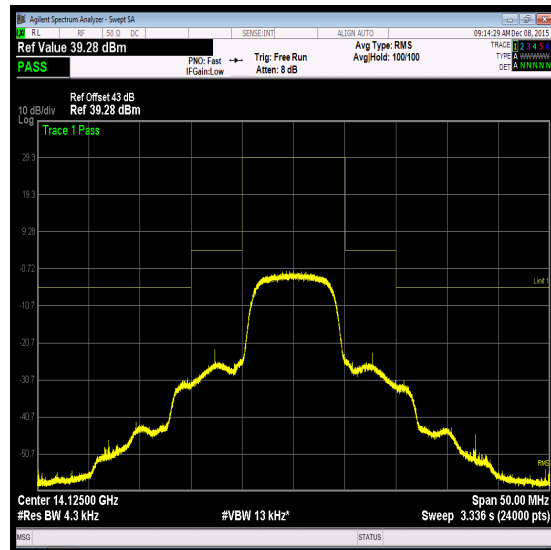

Middle Channel

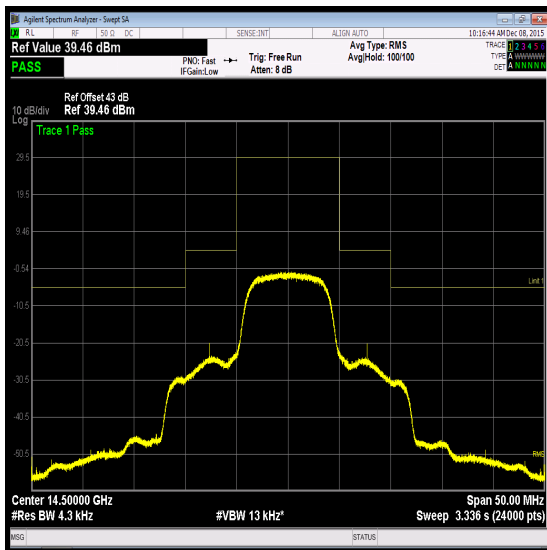

Top Channel

Transmitter Conducted Emissions Masks (continued)

Results: 10 MHz / SF16 / Vertical

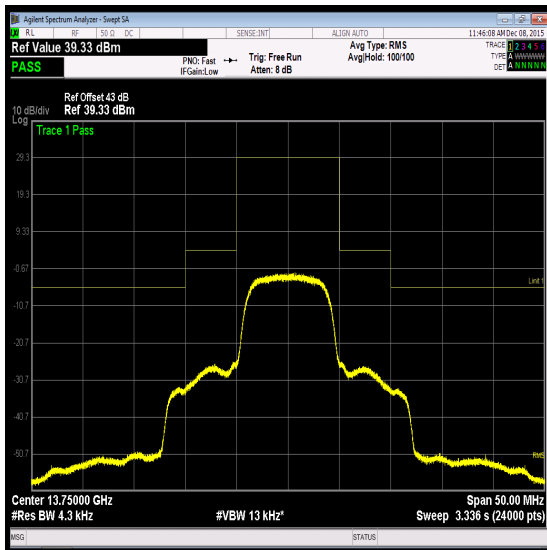

Bottom Channel

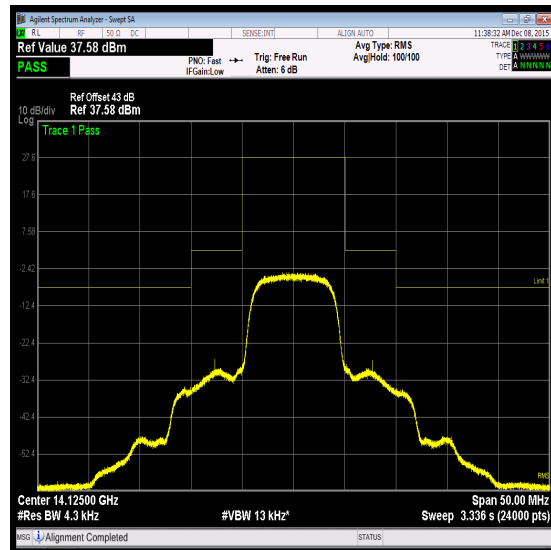

Middle Channel

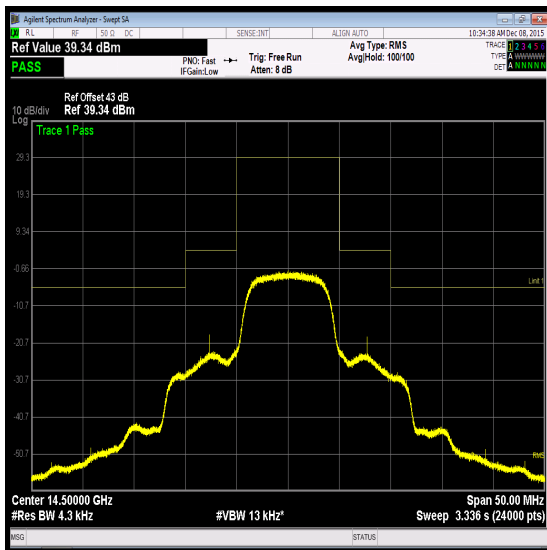

Top Channel

Transmitter Conducted Emissions Masks (continued)

Results: 10 MHz / SF16 / Horizontal

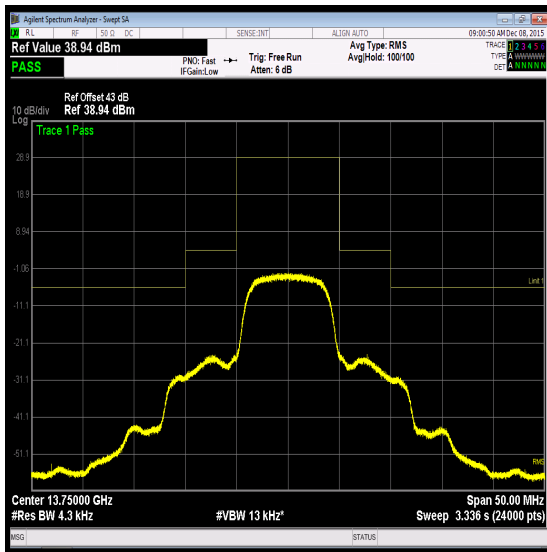

Bottom Channel

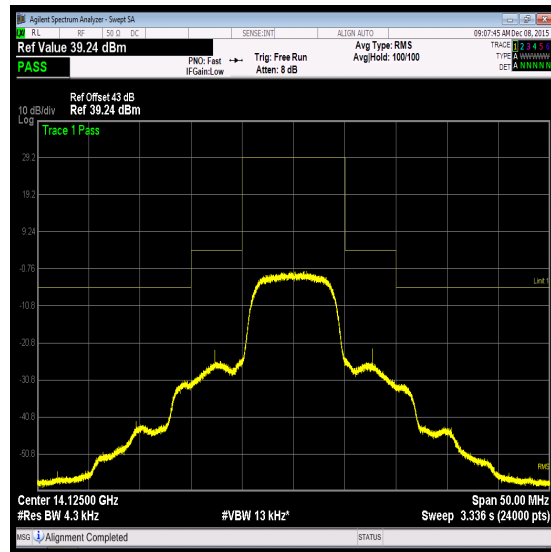

Middle Channel

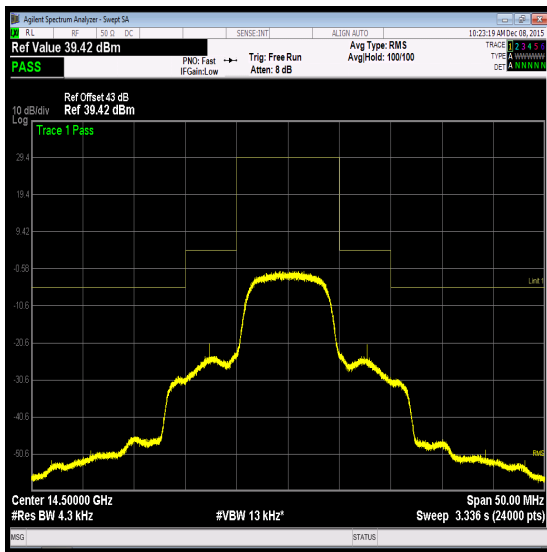

Top Channel

Transmitter Conducted Emissions Masks (continued)**Test Equipment Used:**

Asset No.	Instrument	Manufacturer	Type No.	Serial No.	Date Calibration Due	Cal. Interval (Months)
M1659	Thermohygrometer	JM Handelpunkt	30.5015.13	Not stated	23 Apr 2016	12
A2526	Attenuator	AtlanTecRF	AN18W5-20	832828#1	Calibrated before use	-
A2523	Attenuator	AtlanTecRF	AN18W5-10	832827#1	Calibrated before use	-
A2524	Attenuator	AtlanTecRF	AN18W5-10	832827#2	Calibrated before use	-
C1363	Coax Cable	Rosenberger Micro-Coax	FA147A	68088-01	Calibrated before use	-
M1832	Spectrum Analyser	Agilent	N9010A	MY53470303	26 Mar 2016	24
G085	Signal Generator	Hewlett Packard	83650L	3614A00104	11 Nov 2016	24
M1145	Power Meter	Hewlett Packard	437B	3737U26557	11 Aug 2016	12
M1592	Power Sensor	Hewlett Packard	8487A	3318A02094	22 Sep 2016	12
A2554	Terminator	Micronde	R404610	Not stated	Calibrated before use	-
A2555	Terminator	Micronde	R404610	Not stated	Calibrated before use	-

5.2.4. Transmitter Conducted Emissions (Out of Band)**Test Summary:**

Test Engineer:	Ben Mercer	Test Dates:	11 December 2015 & 15 December 2015
Test Sample Serial Numbers:	311510061 & 311515509		

FCC Reference:	Parts 25.202(f) & 2.1051
Test Method Used:	FCC KDB 971168 Section 6
Frequency Range:	30 MHz to 74 GHz

Environmental Conditions:

Temperature (°C):	24 to 25
Relative Humidity (%):	43 to 45

Note(s):

1. Measurements were performed with the EUT transmitting at maximum power on middle channel, horizontally polarised and using spreading factor 128, as this combination was found to be the worst case during power spectral density tests where all channels and modulation types were observed.
2. Part 25.202(f) specifies emissions limitations in a 4 kHz bandwidth. The closest selectable resolution bandwidth of 4.3 kHz was set, and video bandwidth was set to 13 kHz.
3. Pre-scans were performed in 2 GHz steps with fewer than the 2 measurement points per RBW required by KDB 971168, using a peak detector to reduce measurement duration. Any emissions observed were measured using an RMS detector and at least 2 measurement points per RBW, with trace averaging over 100 traces. An Inquiry was made to the FCC and the response confirmed this method is acceptable.
4. The spectrum analyser was connected to the antenna port on the EUT using suitable attenuation and coaxial cable or waveguide. A reference level offset was entered on the spectrum analyser to compensate for the loss of the attenuator and coaxial cable or waveguide.
5. The customer provided an OMT to adapt the circular waveguide flange at the antenna port to rectangular flanges to enable conducted measurements. The customer stated the worst case loss of the OMT as 0.5 dB. This loss was included in the reference level offset entered on the spectrum analyser.
6. All spurious emissions detected were investigated and found to be greater than 20 dB below the limit. The highest emission level is reported in the table below.

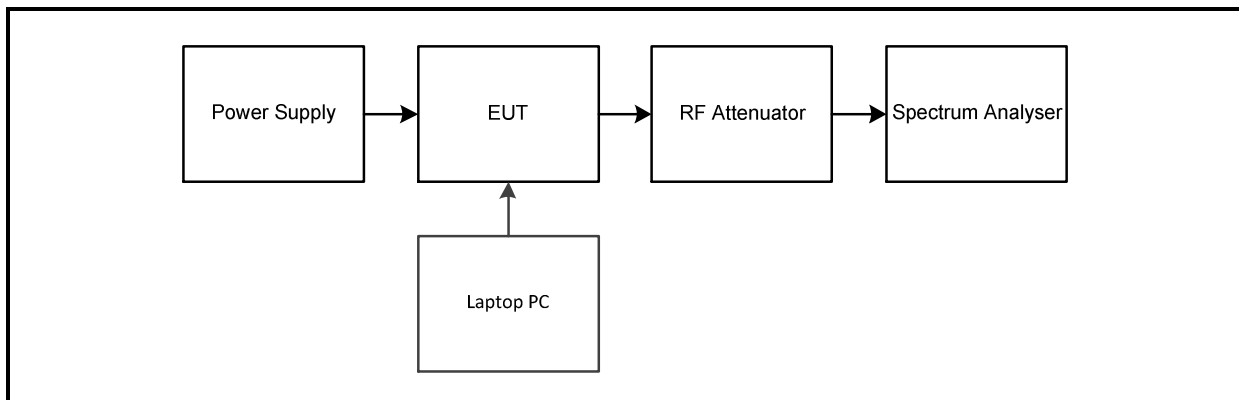
Test setup:

Transmitter Conducted Emissions (Out of Band) (continued)

Results:

Frequency (MHz)	Emission Level (dBm)	Limit (dBm)	Margin (dBm)	Result
14764.997	-45.4	-13.0	32.4	Complied

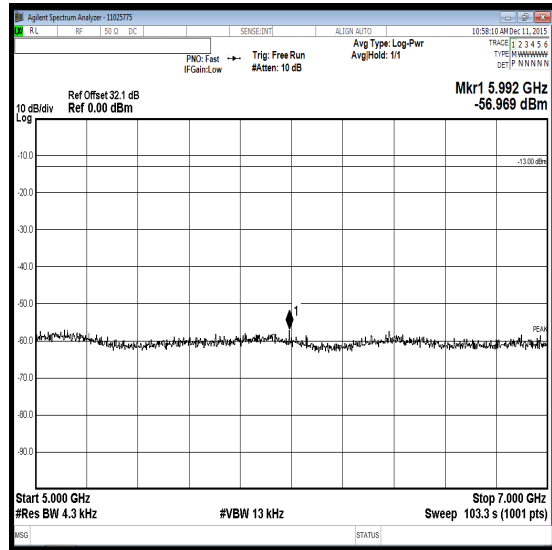
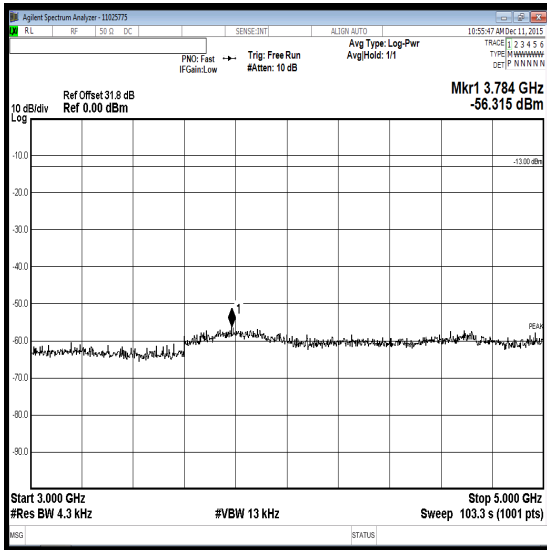
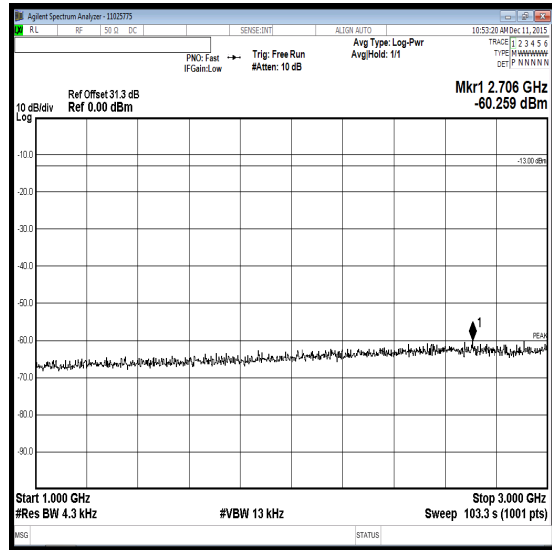
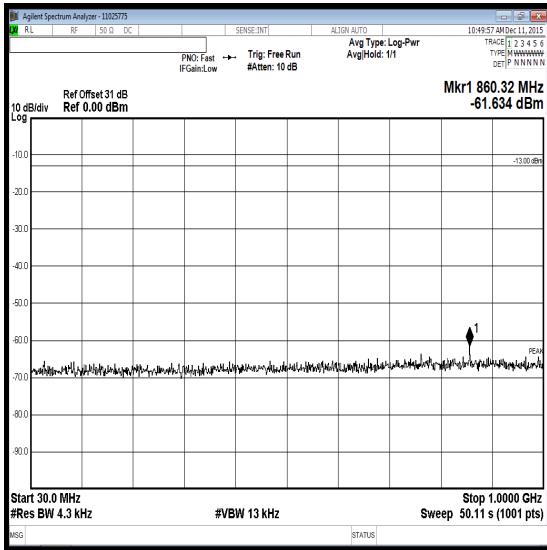

Transmitter Conducted Emissions (Out of Band) (continued)

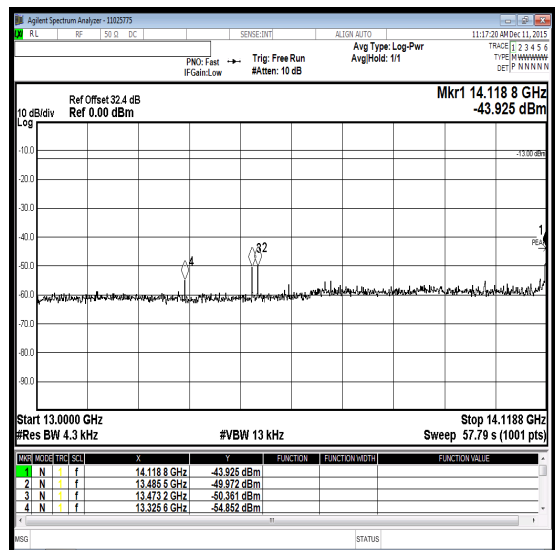
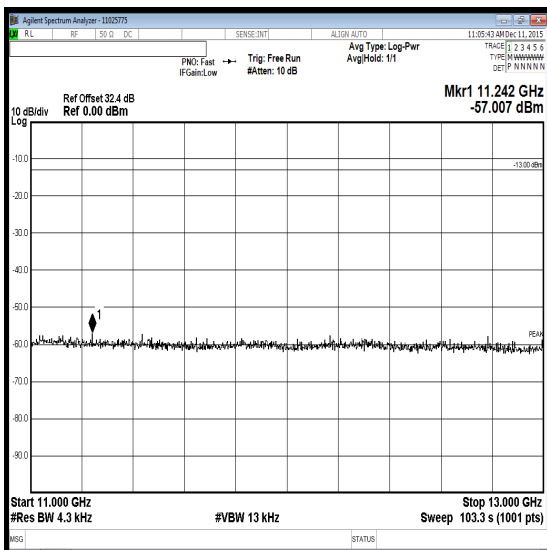
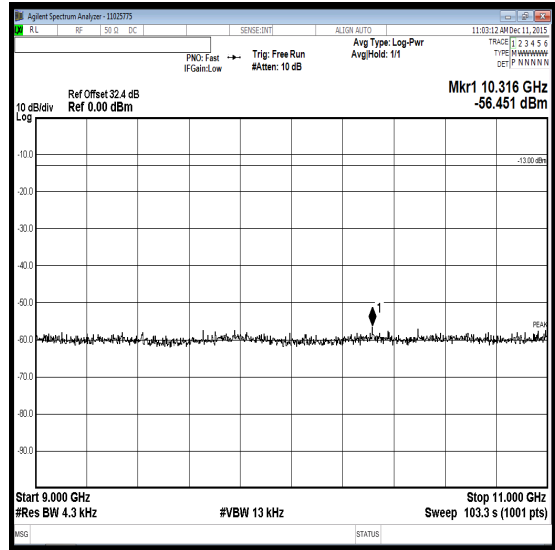
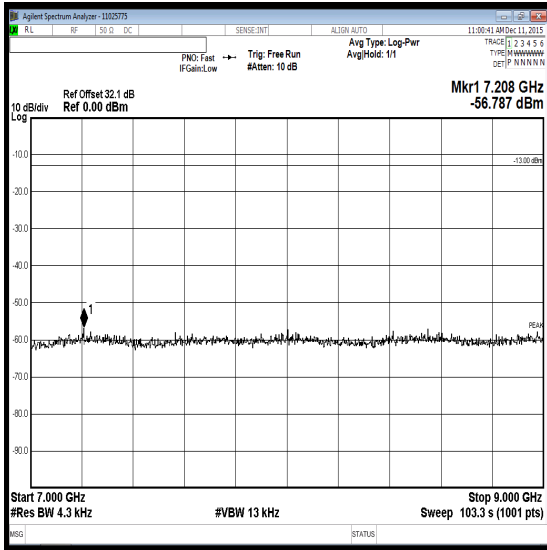

Transmitter Conducted Emissions (Out of Band) (continued)

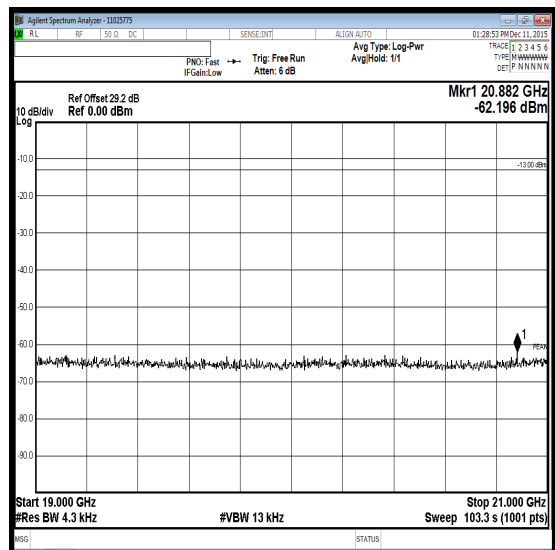
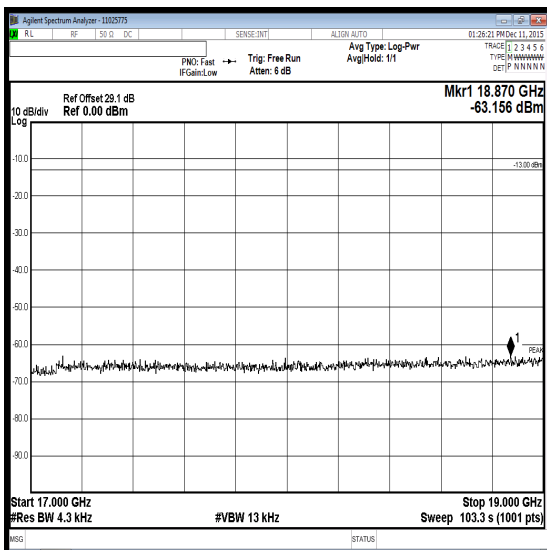
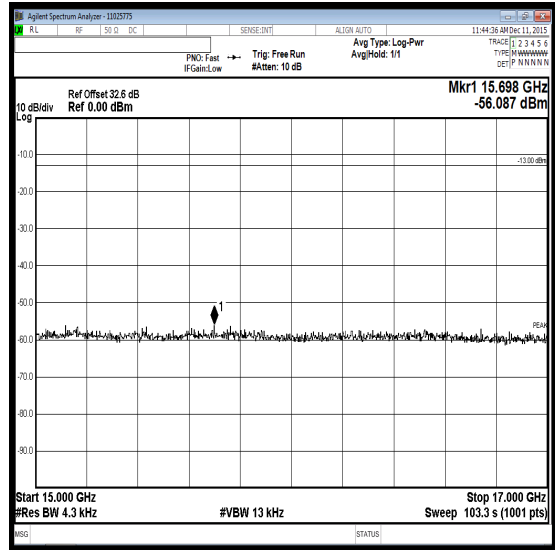
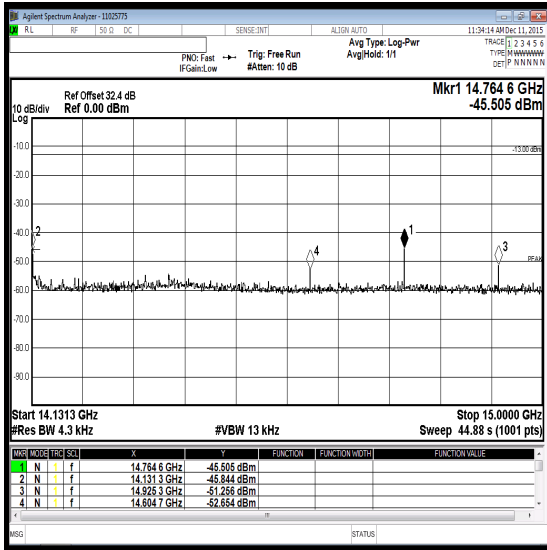

Transmitter Conducted Emissions (Out of Band) (continued)

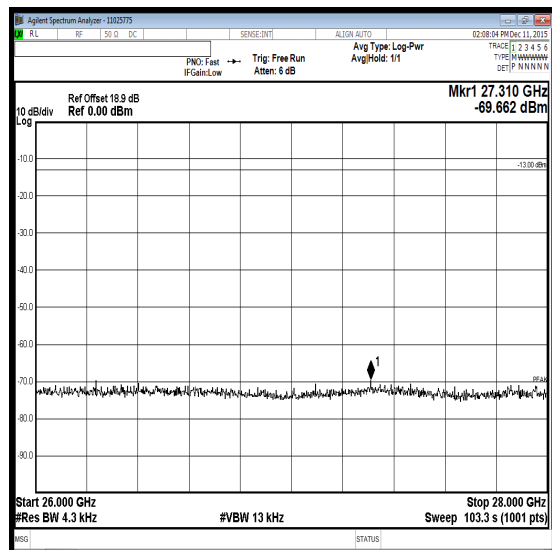
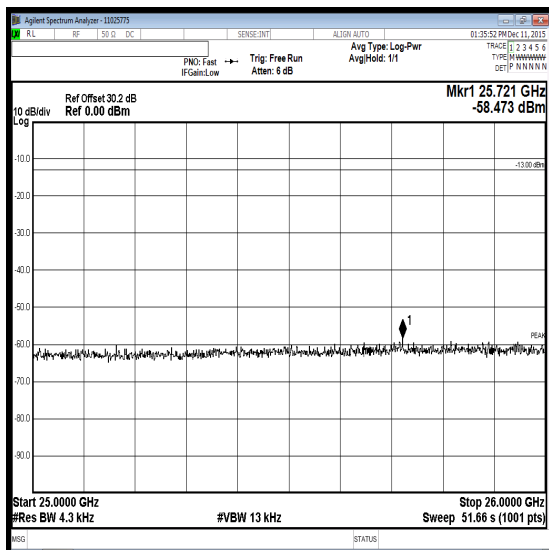
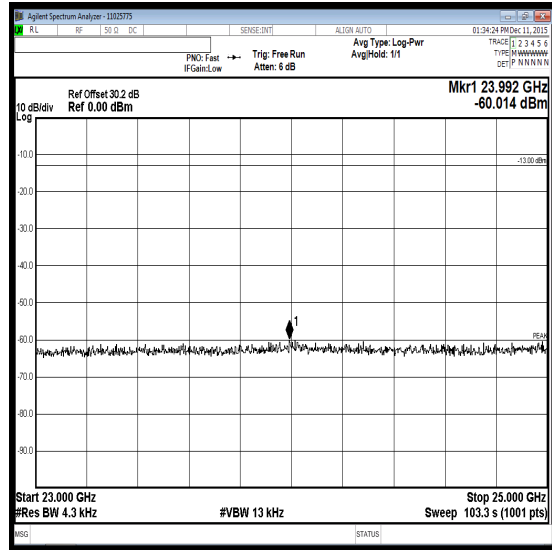
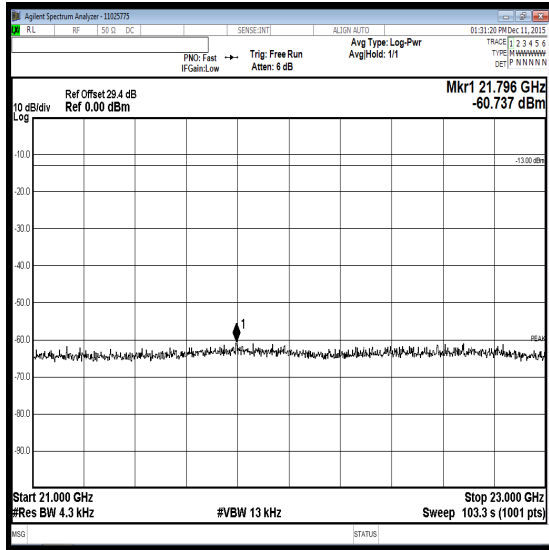

Transmitter Conducted Emissions (Out of Band) (continued)

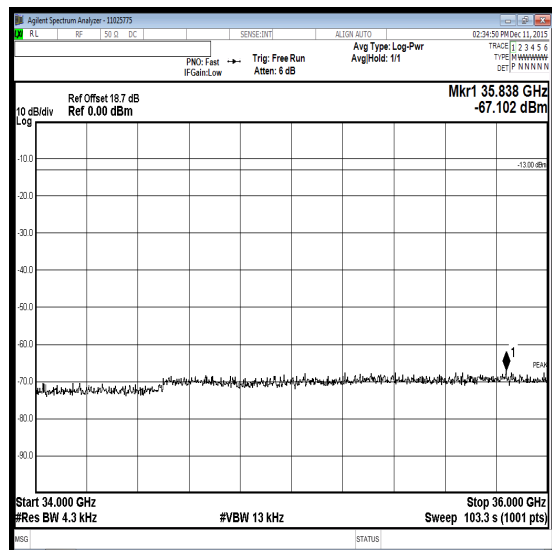
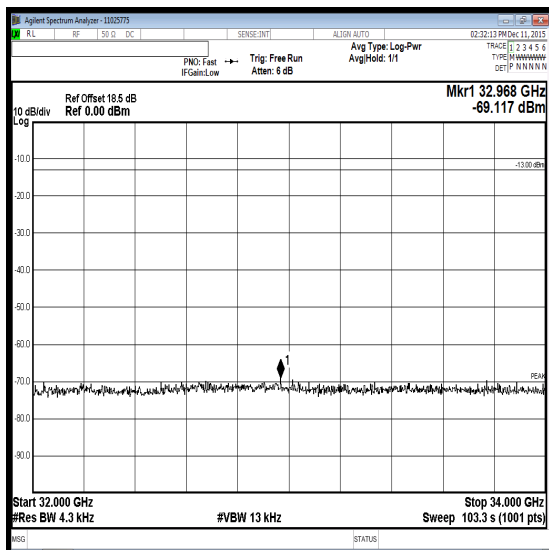
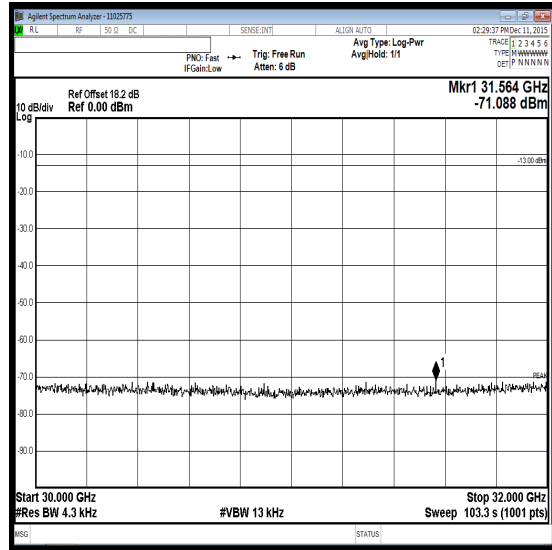
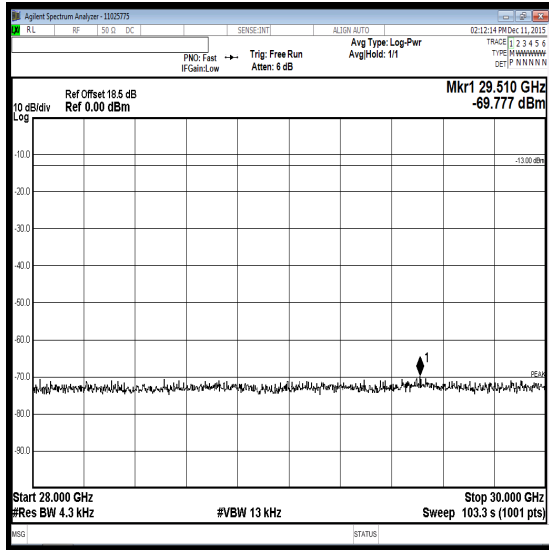

Transmitter Conducted Emissions (Out of Band) (continued)

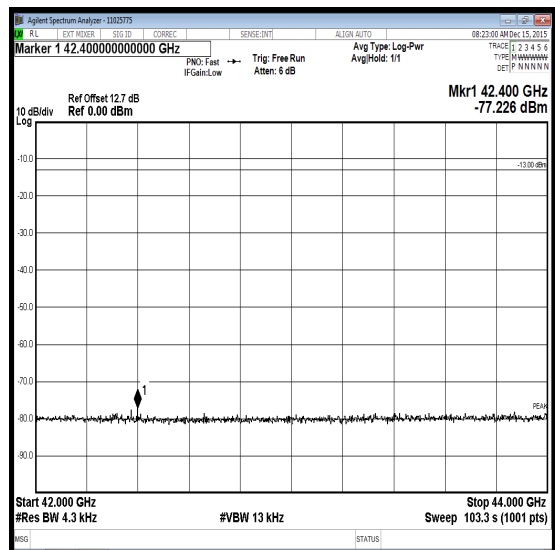
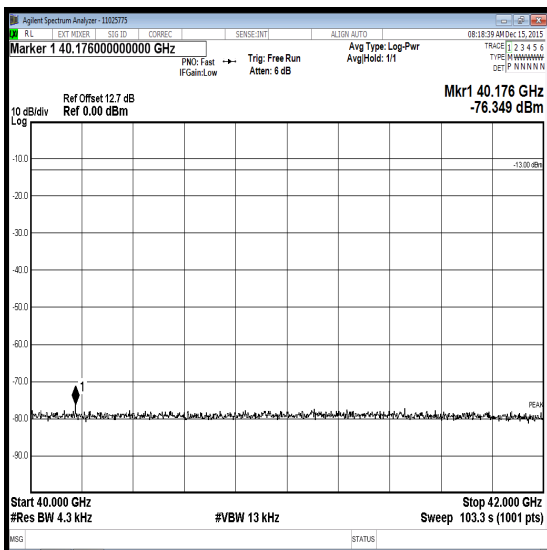
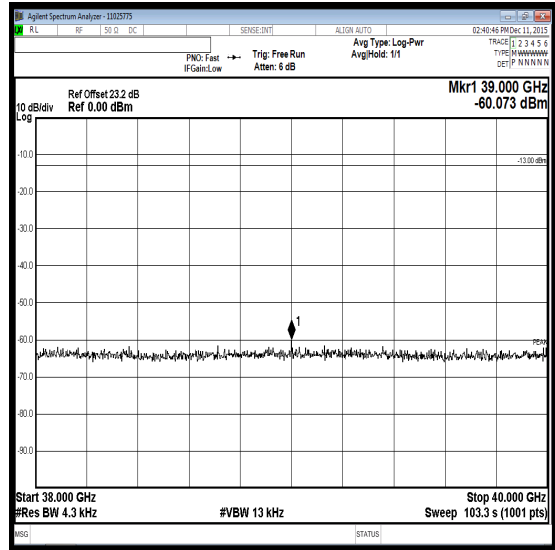
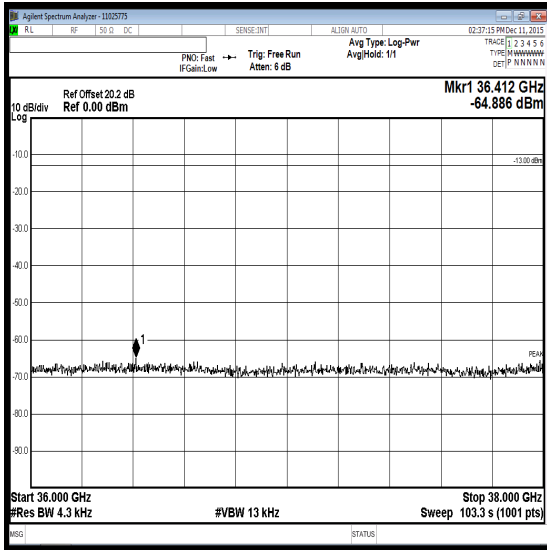

Transmitter Conducted Emissions (Out of Band) (continued)

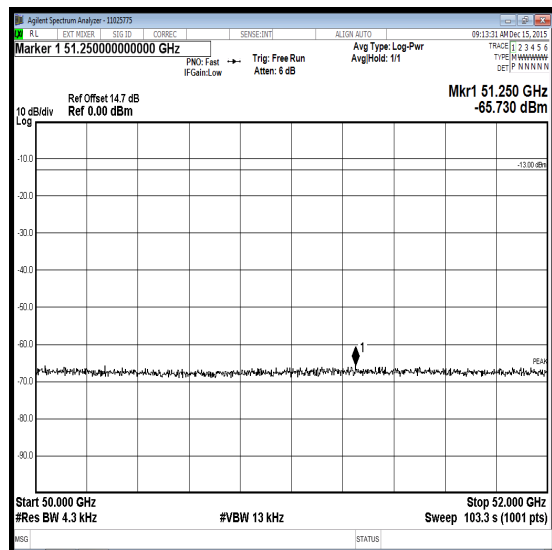
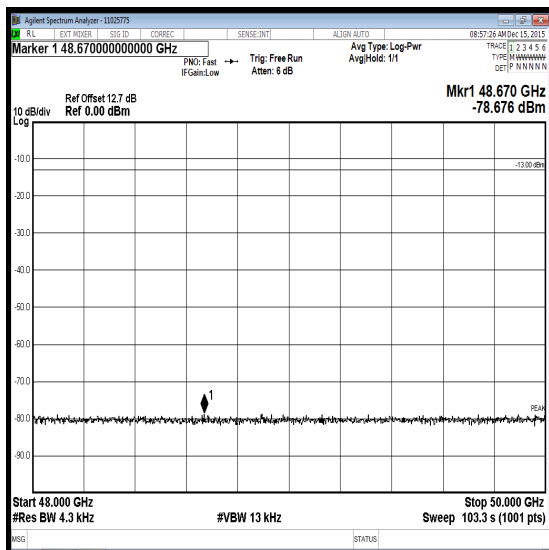
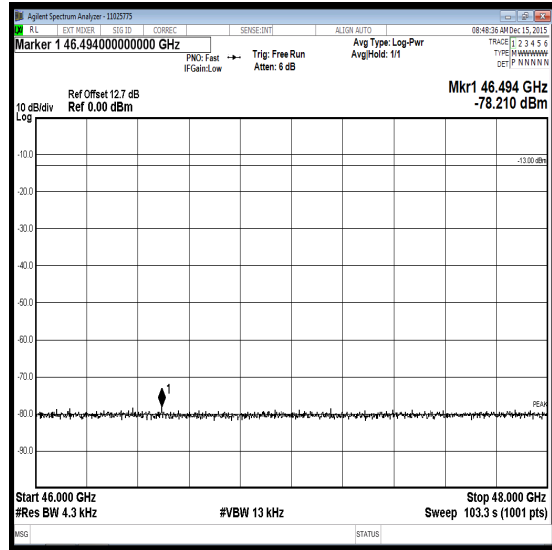
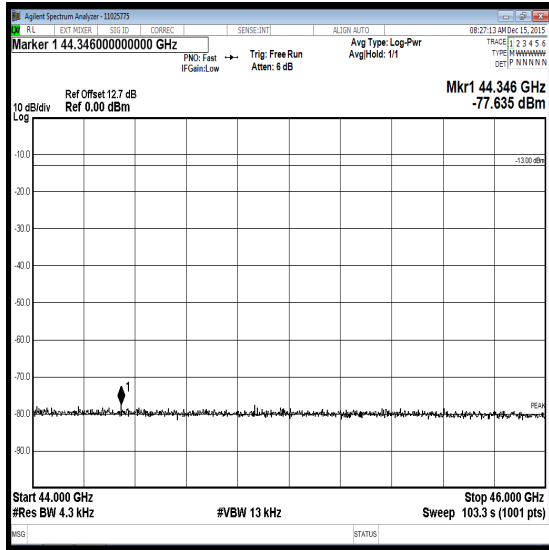

Transmitter Conducted Emissions (Out of Band) (continued)

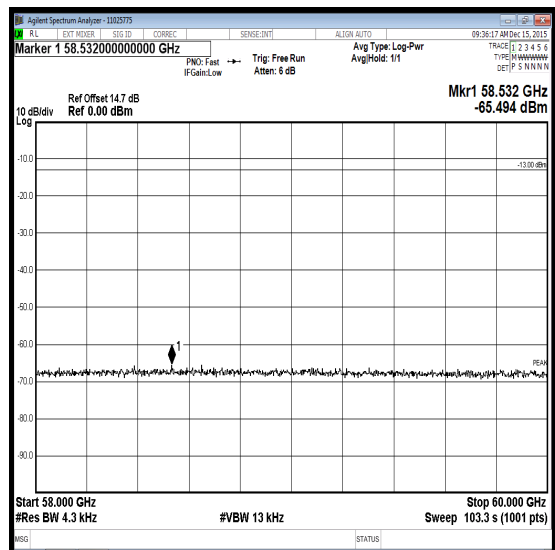
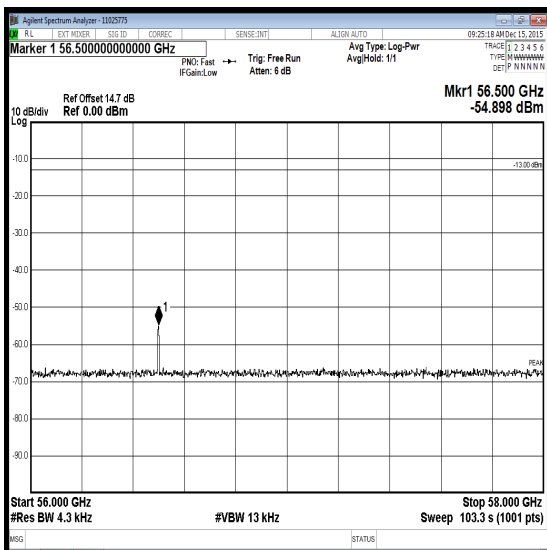
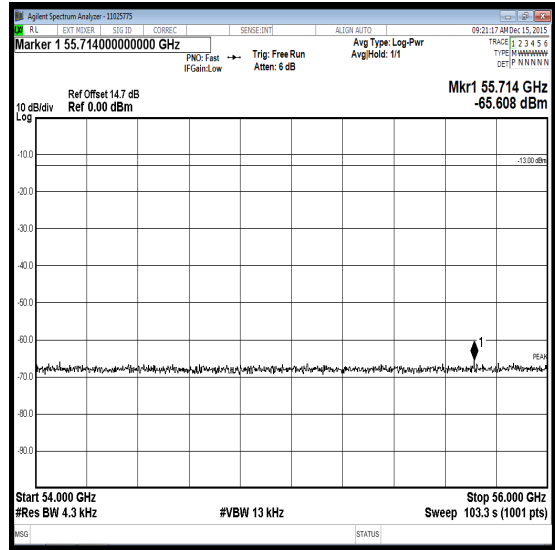
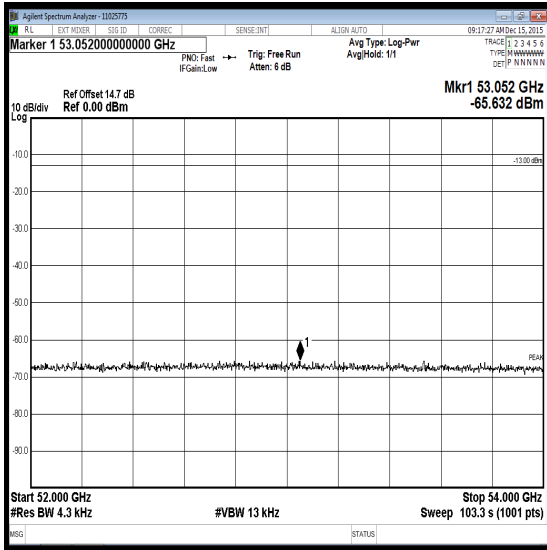

Transmitter Conducted Emissions (Out of Band) (continued)

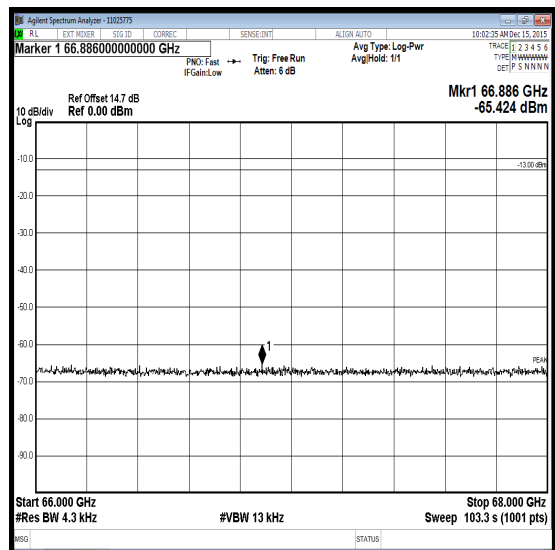
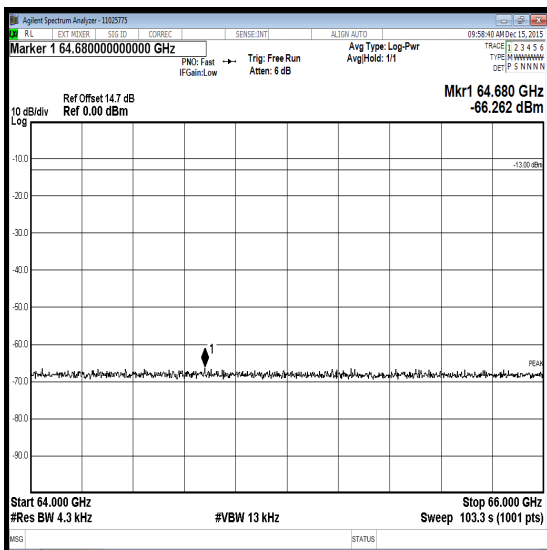
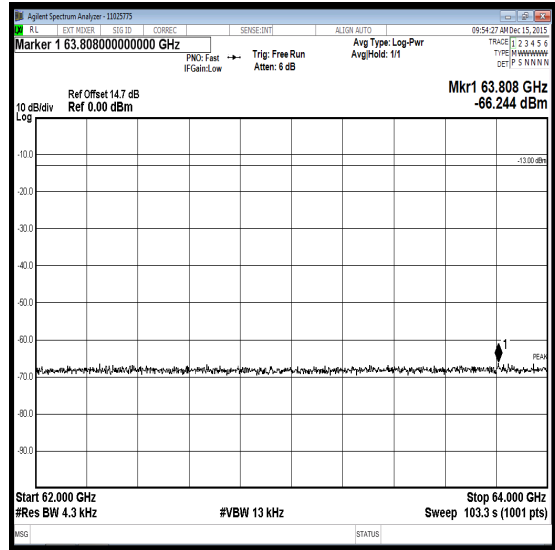
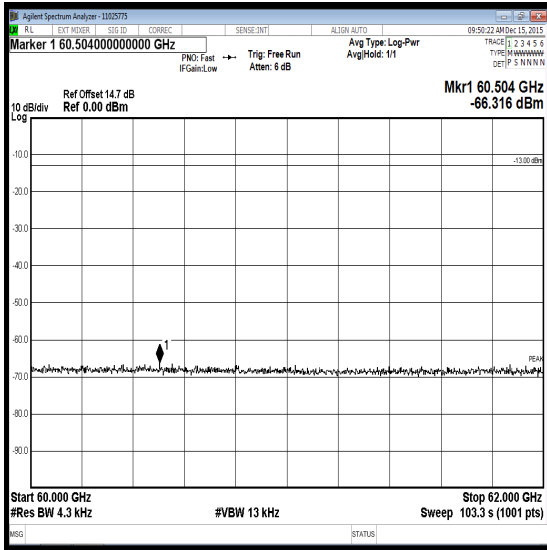

Transmitter Conducted Emissions (Out of Band) (continued)

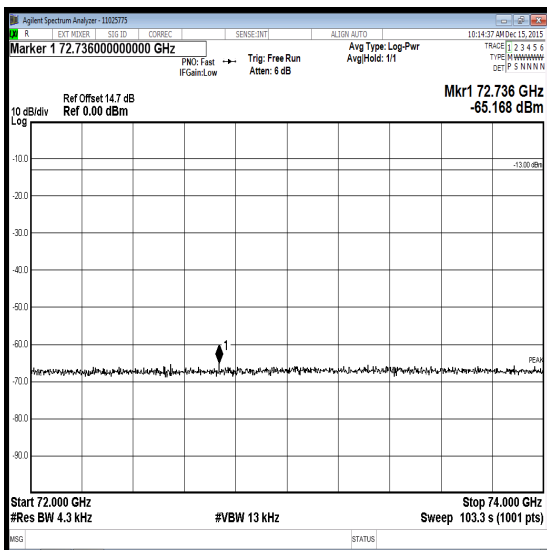
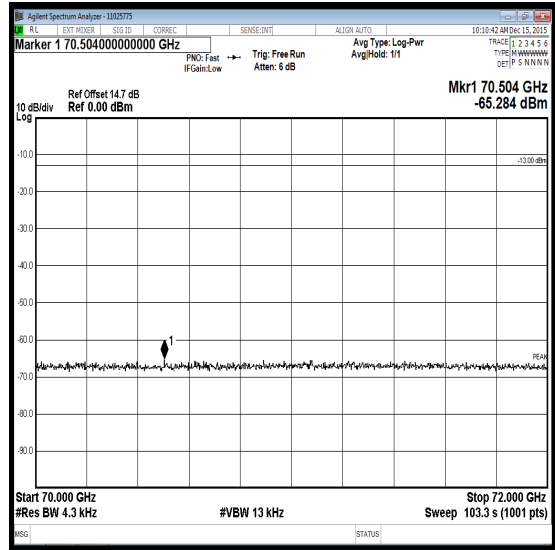
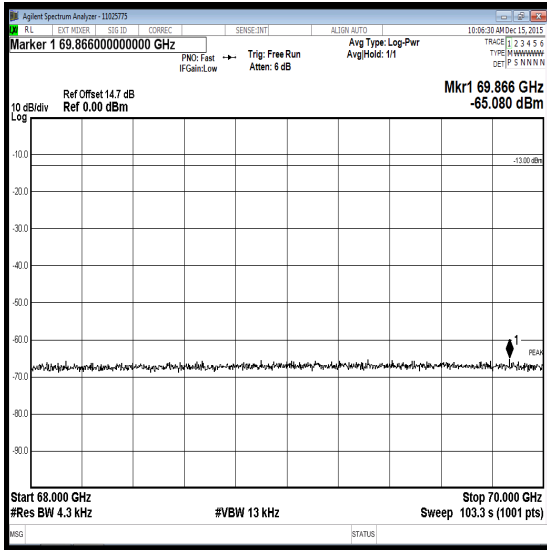

Transmitter Conducted Emissions (continued)**Test Equipment Used:**

Asset No.	Instrument	Manufacturer	Type No.	Serial No.	Date Calibration Due	Cal. Interval (Months)
M1659	Thermohygrometer	JM Handelspunkt	30.5015.13	Not stated	23 Apr 2016	12
A2526	Attenuator	AtlanTecRF	AN18W5-20	832828#1	Calibrated before use	-
A2523	Attenuator	AtlanTecRF	AN18W5-10	832827#1	Calibrated before use	-
C1363	Coax Cable	Rosenberger Micro-Coax	FA147A	68088-01	Calibrated before use	-
M1832	Spectrum Analyser	Agilent	N9010A	MY53470303	26 Mar 2016	24
G085	Signal Generator	Hewlett Packard	83650L	3614A00104	11 Nov 2016	24
M1145	Power Meter	Hewlett Packard	437B	3737U26557	11 Aug 2016	12
M1592	Power Sensor	Hewlett Packard	8487A	3318A02094	22 Sep 2016	12
A1003	Waveguide Taper	Flann	17000-18	Not stated	Calibrated before use	-
A1004	Waveguide Taper	Flann	17000-18	Not stated	Calibrated before use	-
A397	Waveguide Taper	Flann	18000-20	Not stated	Calibrated before use	-
A1447	Waveguide Taper	Flann	18000-20	Not stated	Calibrated before use	-
A1752	Waveguide Taper	Flann	20000-22	Not stated	Calibrated before use	-
A499	Waveguide Taper	Flann	20000-22	Not stated	Calibrated before use	-
A1756	Waveguide Taper	Flann	22000-24	Not stated	Calibrated before use	-
A1180	Waveguide Taper	Flann	22000-24	Not stated	Calibrated before use	-
A2060	Waveguide Adapter	Flann	20094-SF40	196550	Calibrated before use	-
A2061	Waveguide Adapter	Flann	20094-SF40	196551	Calibrated before use	-
A1869	Waveguide Adapter	Quasar	QRA22PQB4 028KF	Not stated	Calibrated before use	-
A1873	Waveguide Adapter	Quasar	QRA22PQB4 028KF	Not stated	Calibrated before use	-
A2152	Waveguide Adapter	Flann	24093-VF50	204933	Calibrated before use	-
A2153	Waveguide Adapter	Flann	24093-VF50	204934	Calibrated before use	-
A414	Waveguide Attenuator	Quasar	QFA18SQB- 402-402B10	30107-2	Calibrated before use	-
A2158	Waveguide Taper	Flann	24000-25	204918	Calibrated before use	-
A2157	Waveguide Taper	Flann	24000-25	204263	Calibrated before use	-
M197	Harmonic Mixer	Hewlett Packard	11970U	2332A00782	30 Sep 2017	36
M194	Harmonic Mixer	Hewlett Packard	11970V	2521A01005	23 Apr 2017	36
A2343	Diplexer	Farran	DIP-1-0001	FTL 3098B	Calibration not req	-
G094	Source Module	Hewlett Packard	83557A	2948A00475	Calibrated before use	-
M291	Power Sensor	Hewlett Packard	V8486A	US39010039	30 Oct 2016	24
M281	Power Meter	Hewlett Packard	E4418A	GB37170210 -01	27 Jan 2016	12
A2554	Terminator	Micronde	R404610	Not stated	Calibrated before use	-
A2555	Terminator	Micronde	R404610	Not stated	Calibrated before use	-

5.2.5. Transmitter Radiated Emissions**Test Summary:**

Test Engineers:	David Doyle & Ben Mercer	Test Dates:	10 December 2015 to 17 December 2015
Test Sample Serial Numbers:	311510061 & 3115155009		

FCC Reference:	Parts 25.202(f) & 2.1053
Test Method Used:	FCC KDB 971168 Section 7 and ANSI C63.10 Sections 6.3, 6.5, 6.6, 9.8, 9.9 & 9.12
Frequency Range:	30 MHz to 74 GHz

Environmental Conditions:

Temperature (°C):	24 to 26
Relative Humidity (%):	38 to 40

Note(s):

- Measurements were performed with the EUT transmitting at maximum power on middle channel, horizontally polarised and using spreading factor 128, as this combination was found to be the worst case during power spectral density tests where all channels and modulation types were observed.
- The antenna port was terminated with a suitable 50 Ω load during the tests.
- Part 25.202(f) specifies emissions limitations in a 4 kHz bandwidth. For measurements below 26.5 GHz, the closest selectable resolution bandwidth of 5 kHz was set, and video bandwidth was set to 20 kHz. For measurements above 26.5 GHz, the closest selectable resolution bandwidth of 4.3 kHz was set, and video bandwidth was set to 13 kHz.
- Pre-scans were performed in a maximum of 3 GHz steps with fewer than the 2 measurement points per RBW required by KDB 971168, using a peak detector to reduce measurement duration. Any emissions observed were measured using an RMS detector and at least 2 measurement points per RBW, with trace averaging over 100 traces. An Inquiry was made to the FCC and the response confirmed this method is acceptable.
- The emission identified by marker 1 on the 12.75 to 15 GHz plot is the EUT fundamental.
- All spurious emissions detected were investigated and found to be greater than 20 dB below the limit. The highest emission level is reported in the table below.

Transmitter Radiated Emissions (continued)

Test setup:

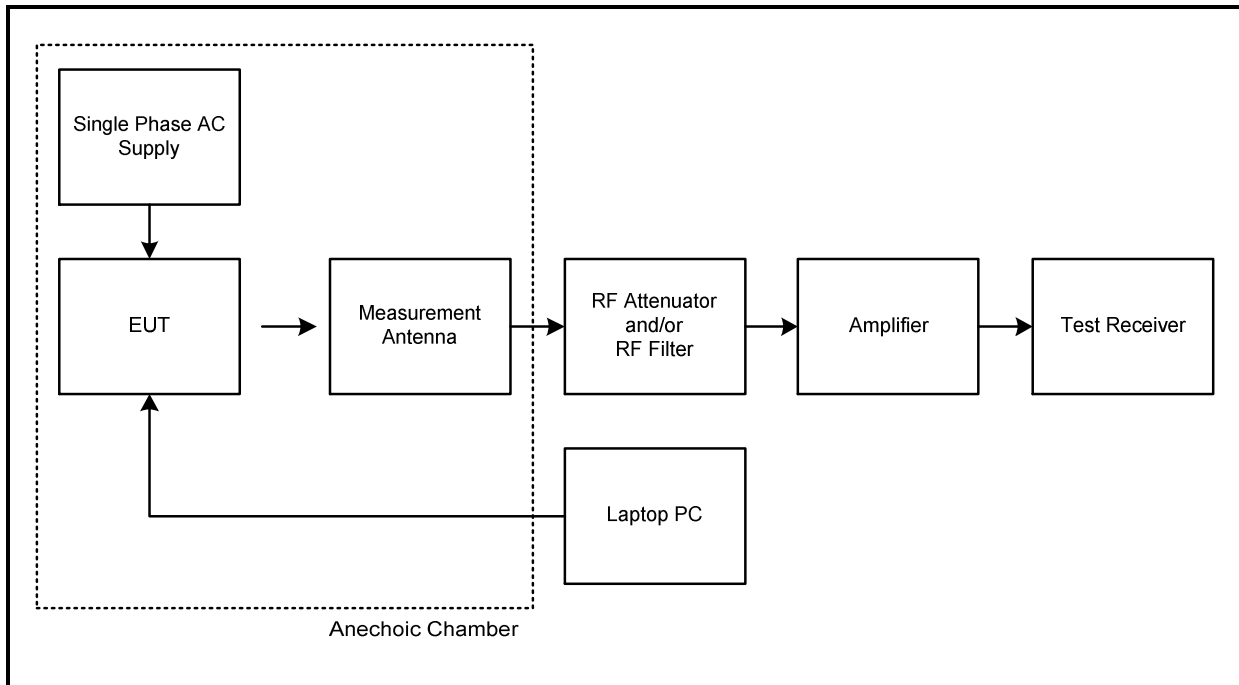
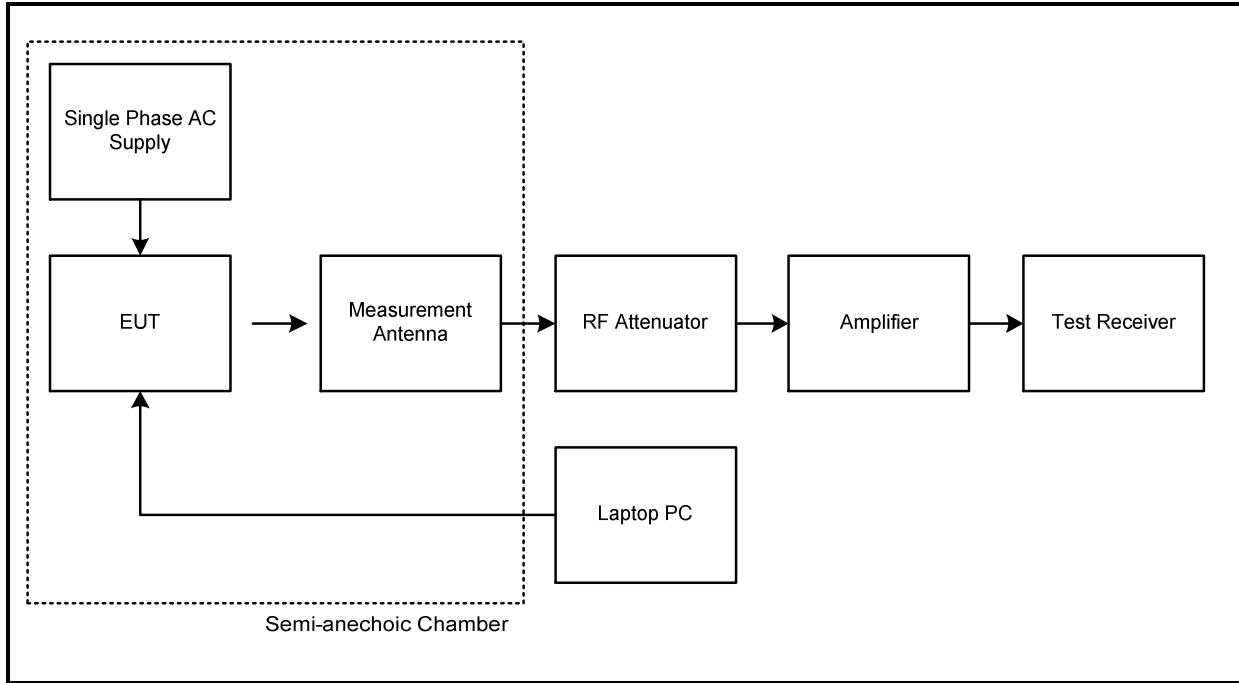

Transmitter Radiated Emissions (continued)

Results:

Frequency (MHz)	Emission Level (dBm)	Limit (dBm)	Margin (dBm)	Result
399.975	-33.2	-13.0	20.2	Complied

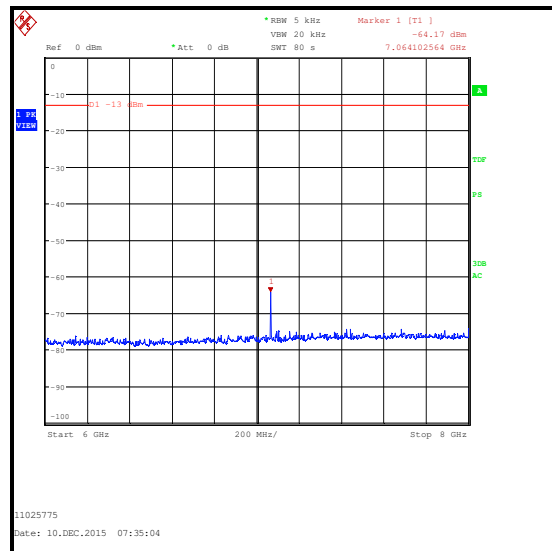
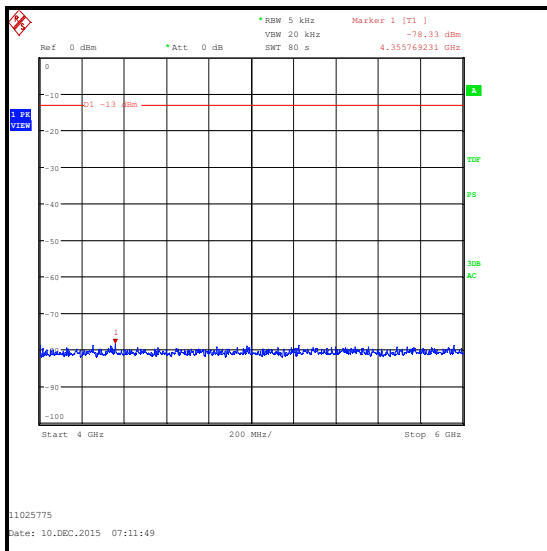
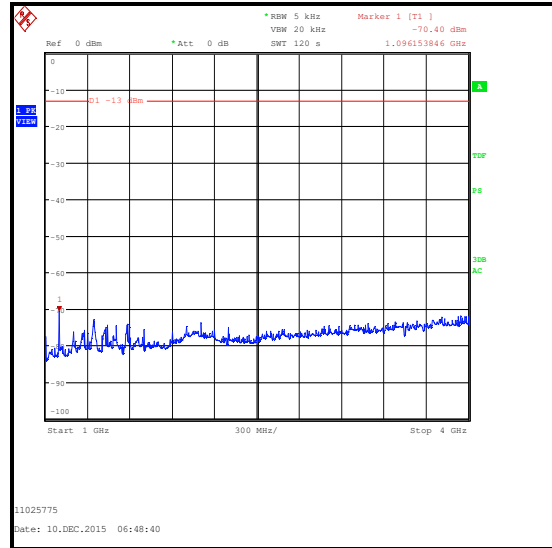
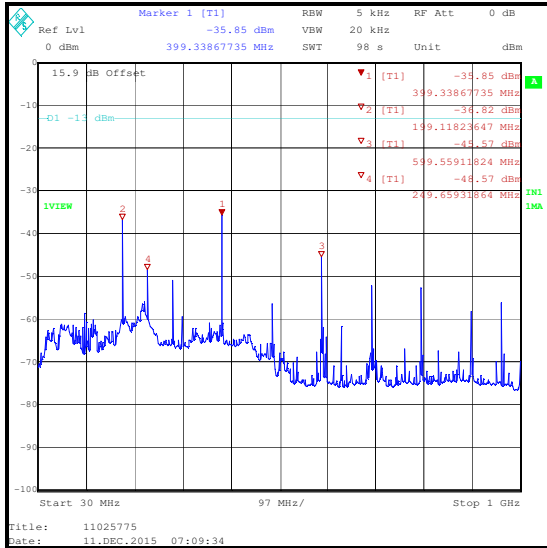

Transmitter Radiated Emissions (continued)

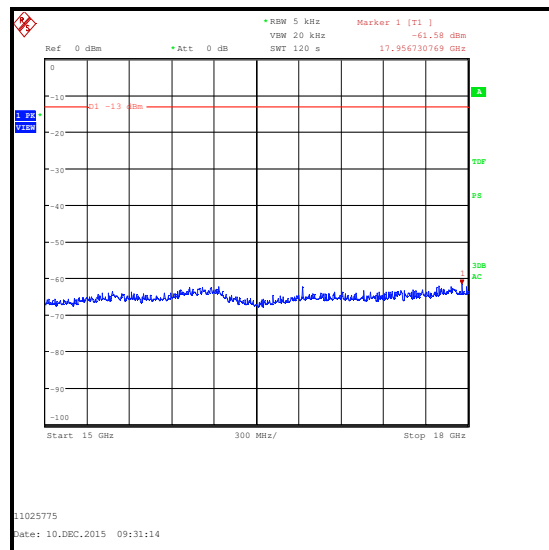
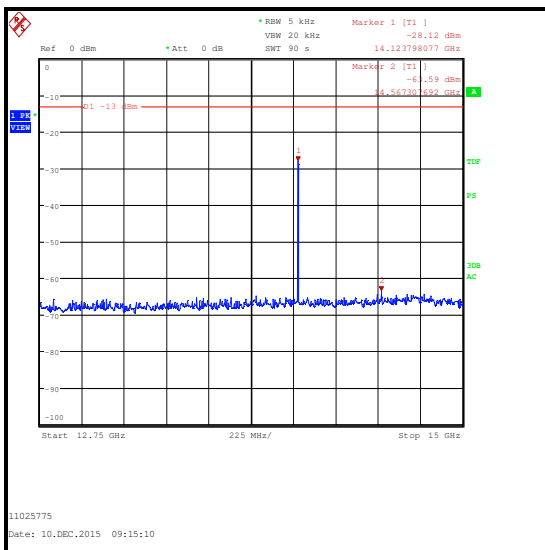
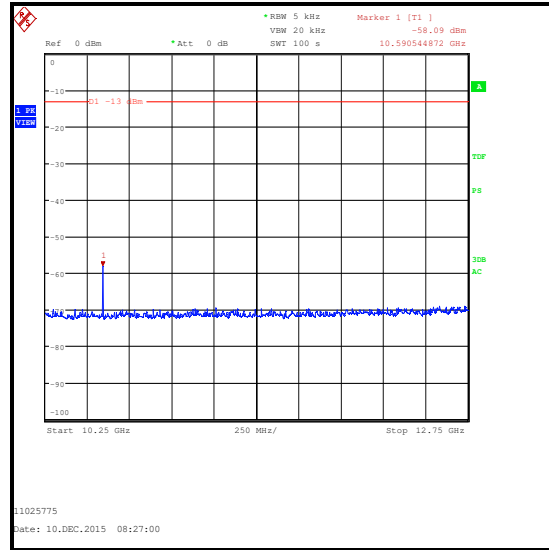
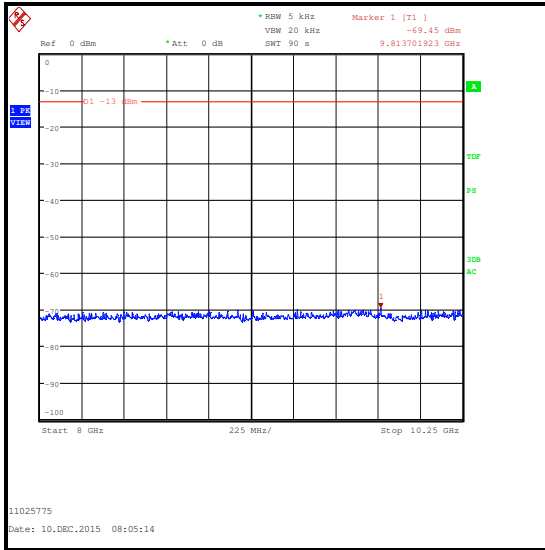

Transmitter Radiated Emissions (continued)

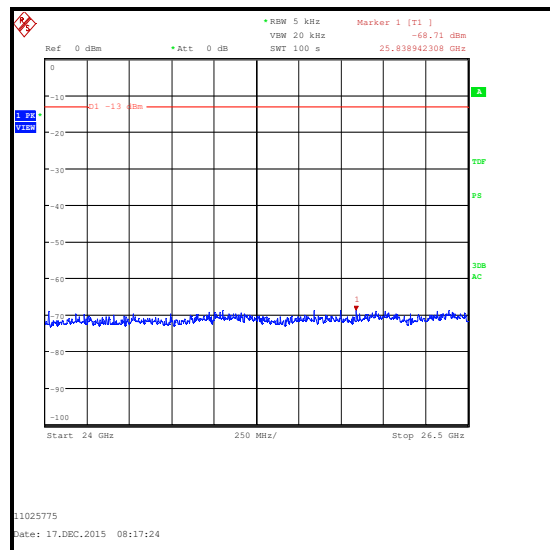
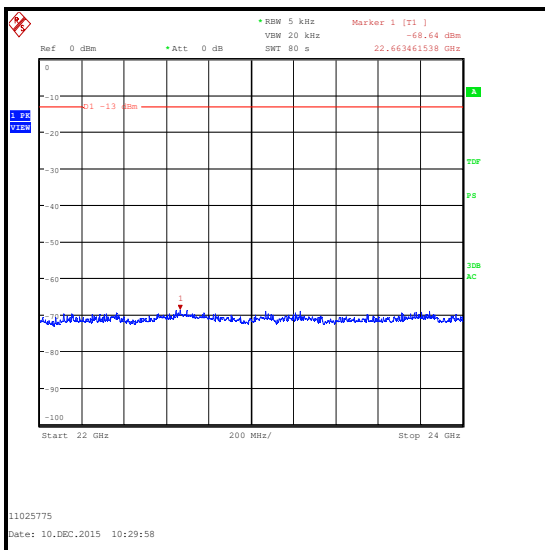
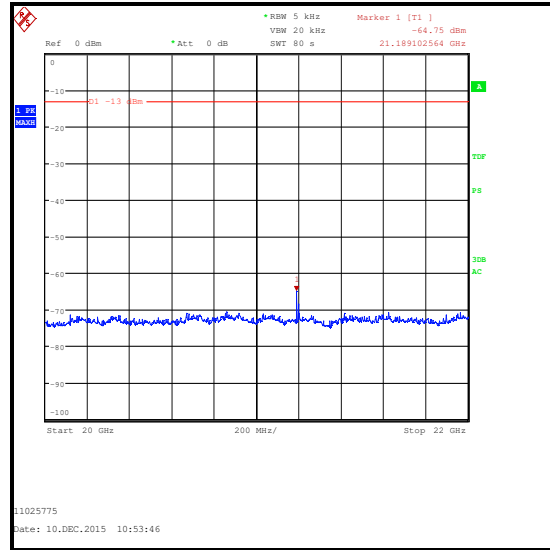
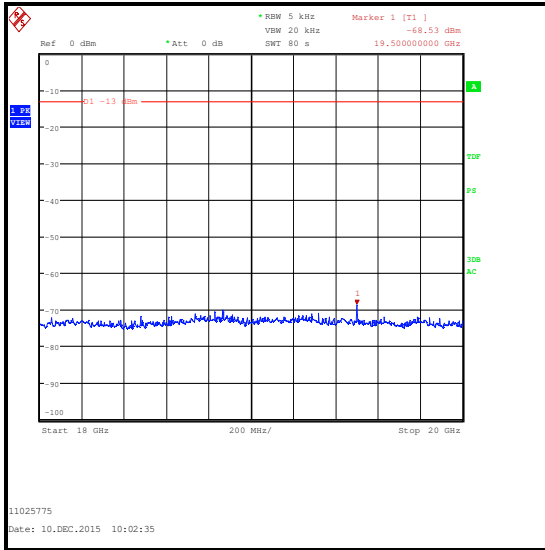

Transmitter Radiated Emissions (continued)

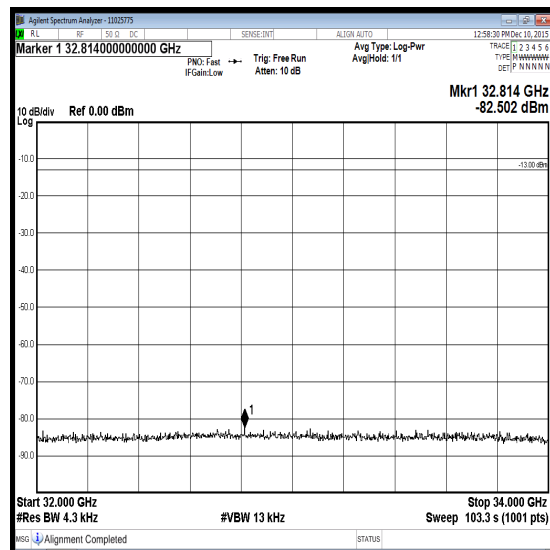
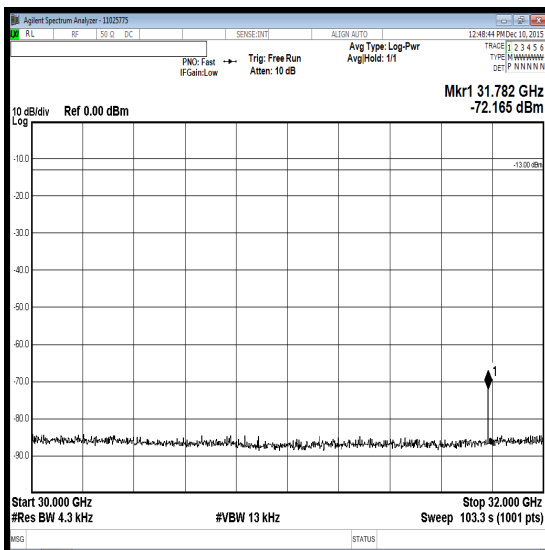
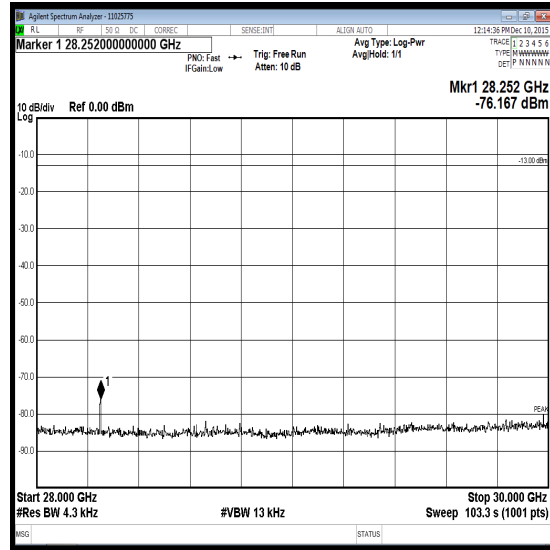
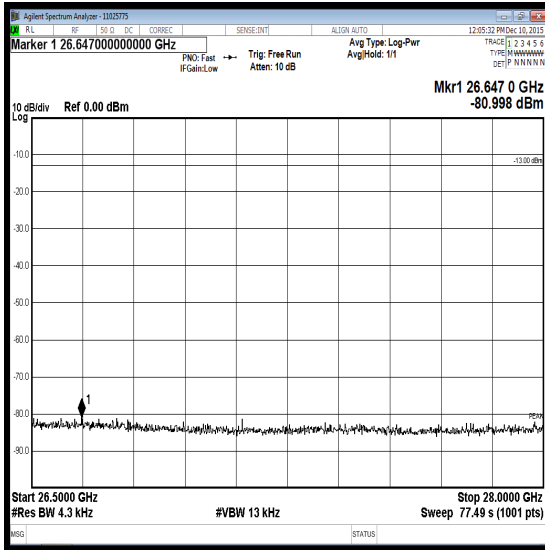

Transmitter Radiated Emissions (continued)

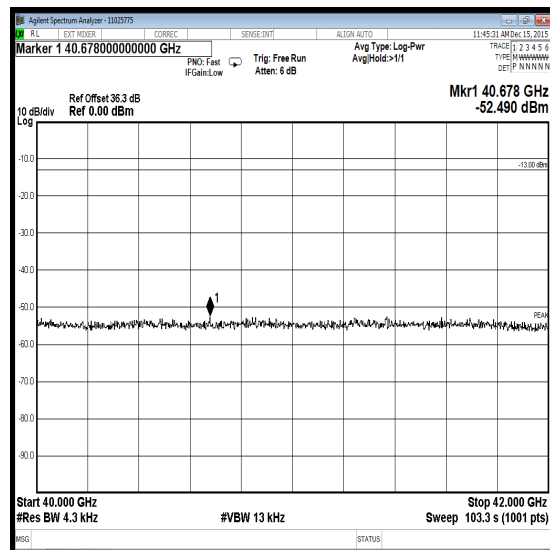
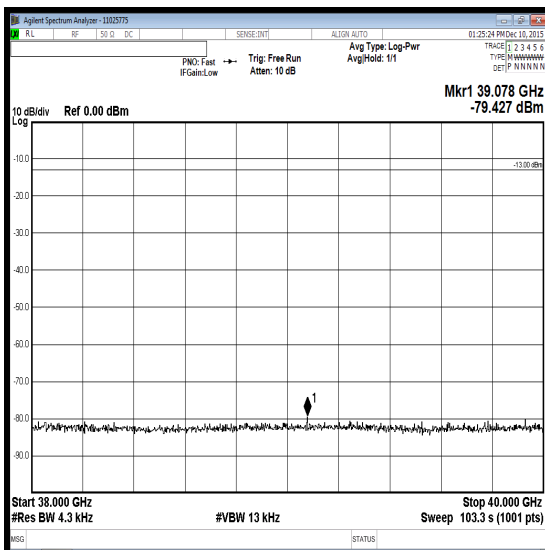
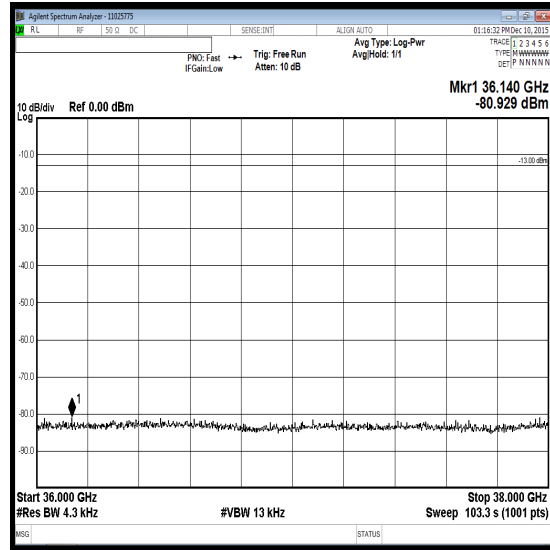
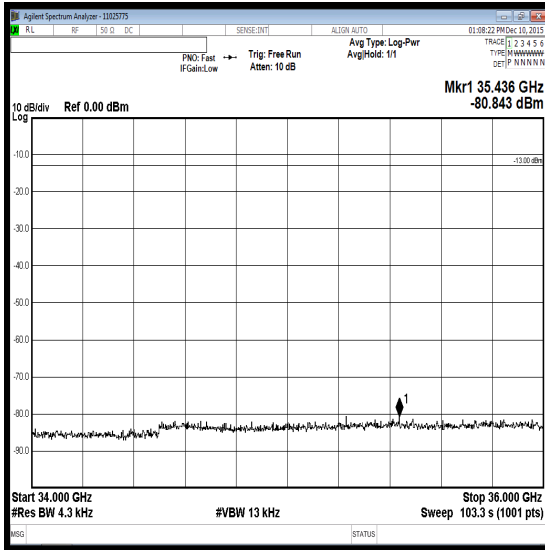

Transmitter Radiated Emissions (continued)

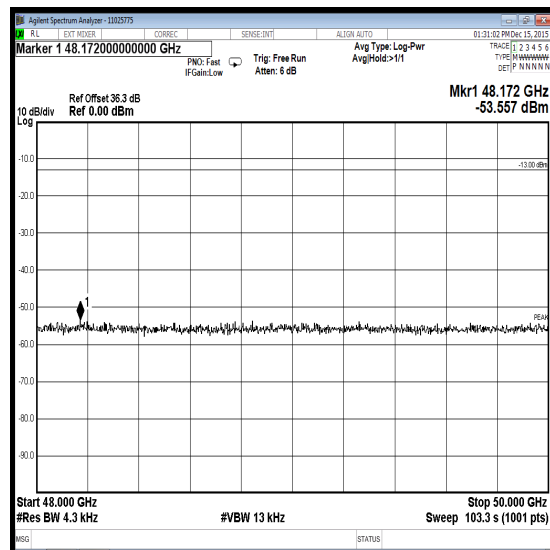
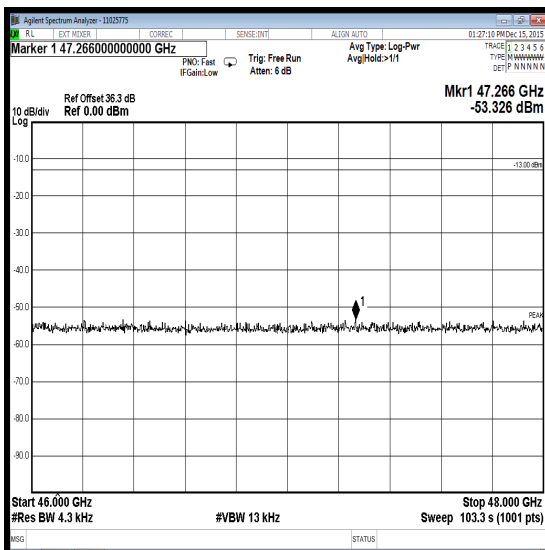
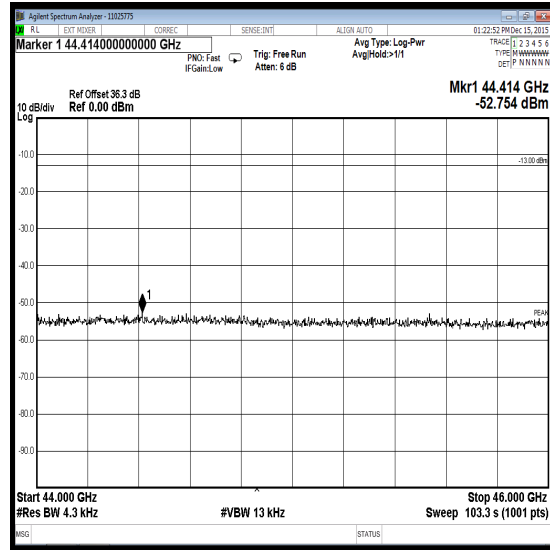
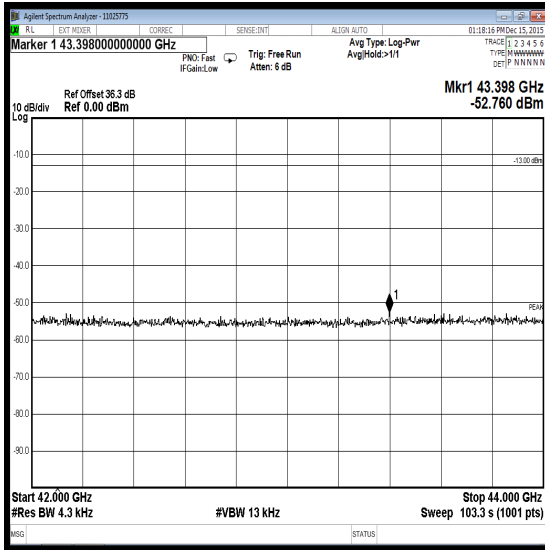

Transmitter Radiated Emissions (continued)

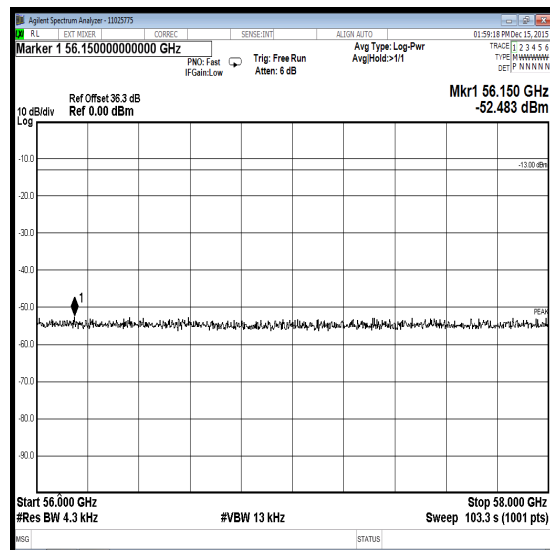
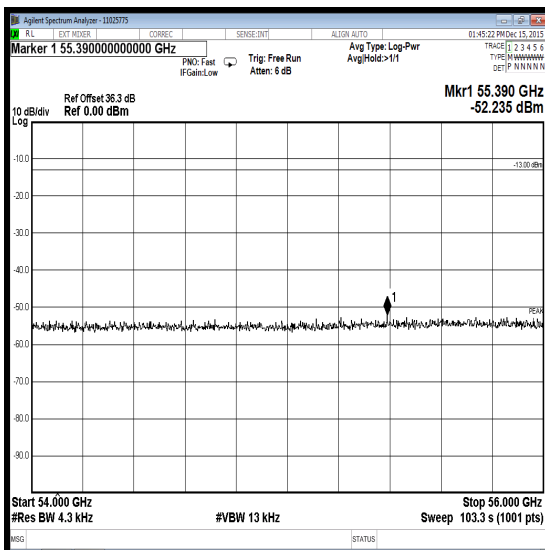
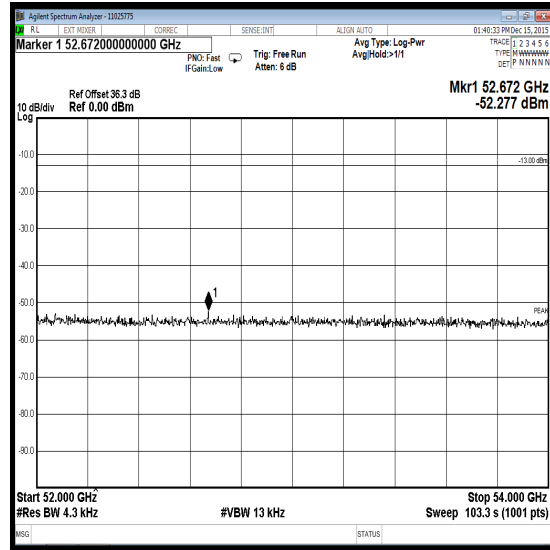
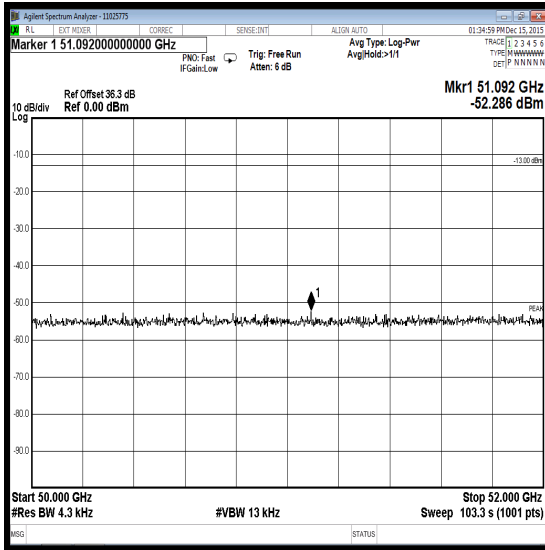

Transmitter Radiated Emissions (continued)

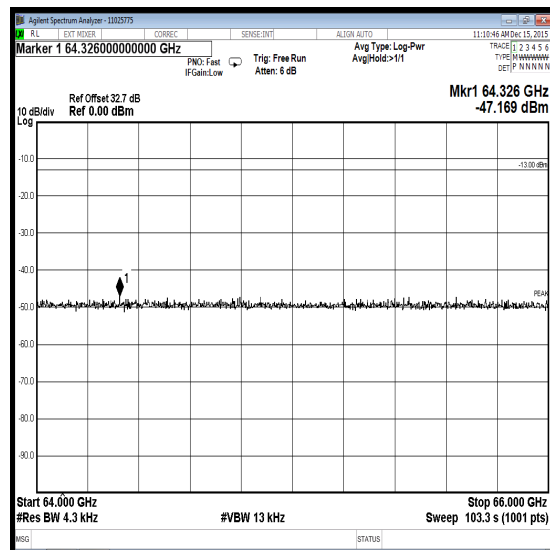
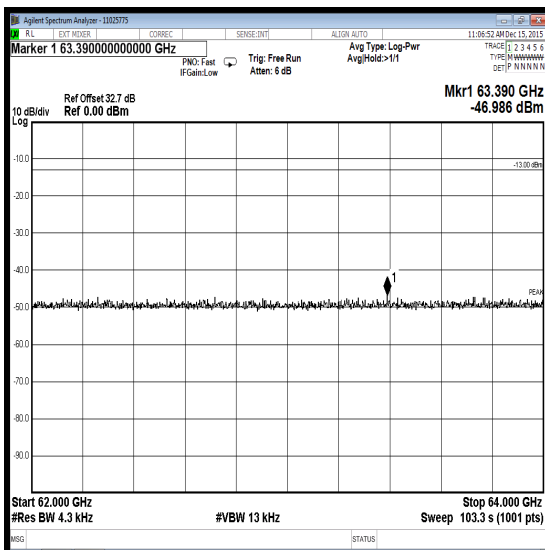
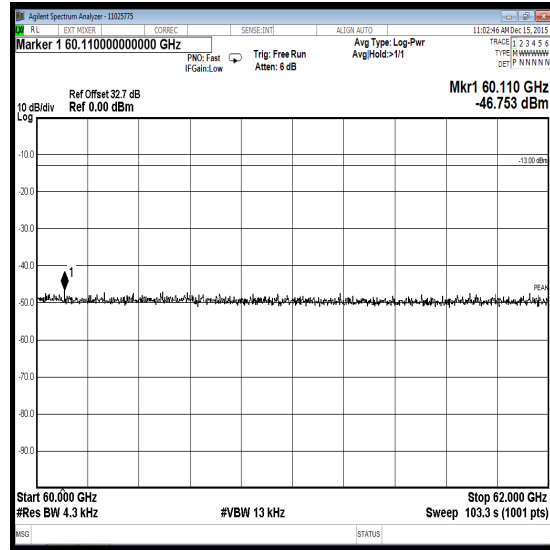
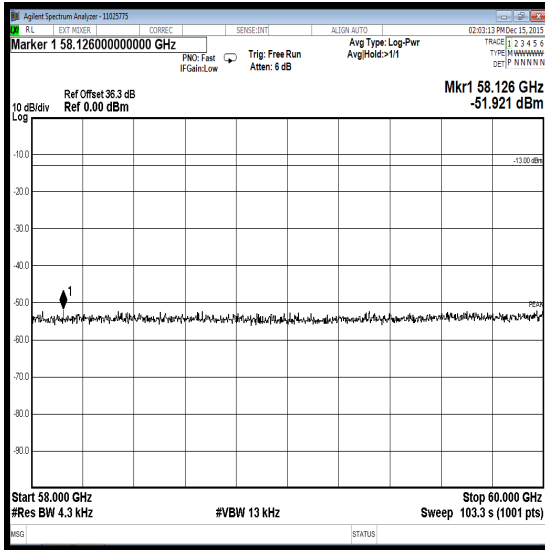

Transmitter Radiated Emissions (continued)

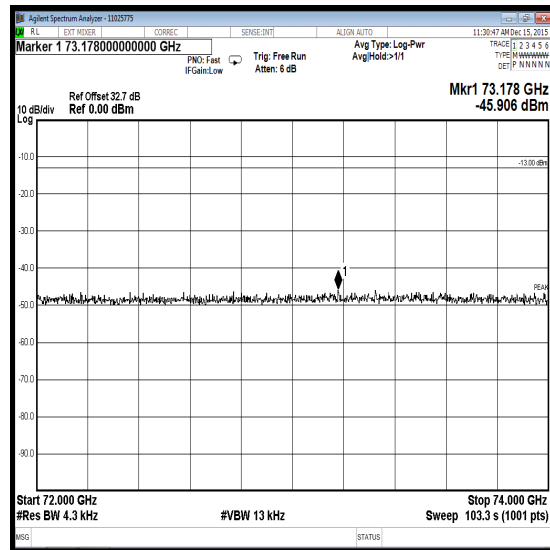
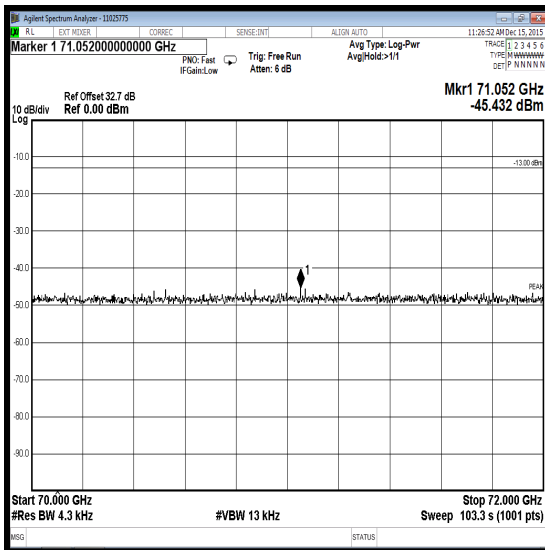
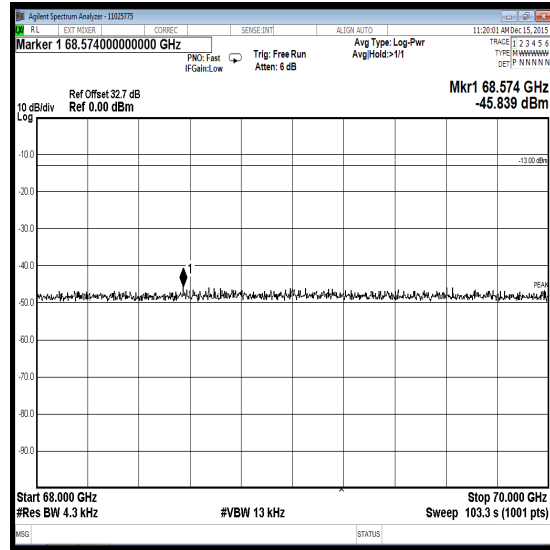
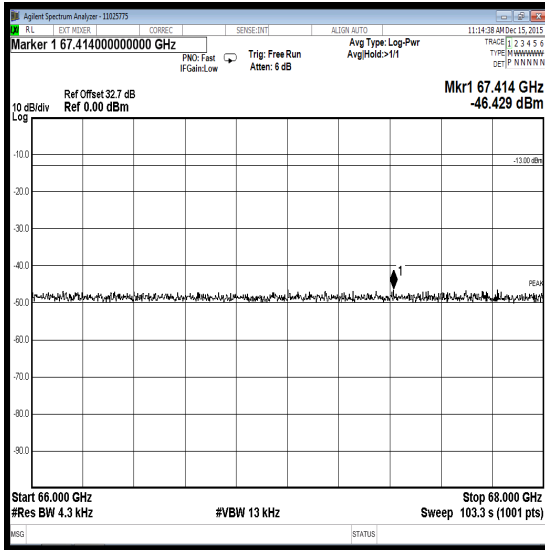

Transmitter Radiated Emissions (continued)**Test Equipment Used:**

Asset No.	Instrument	Manufacturer	Type No.	Serial No.	Date Calibration Due	Cal. Interval (Months)
M1659	Thermohygrometer	JM Handelpunkt	30.5015.13	Not stated	23 Apr 2016	12
M1832	Spectrum Analyser	Agilent	N9010A	MY53470303	26 Mar 2016	24
M197	Harmonic Mixer	Hewlett Packard	11970U	2332A00782	30 Sep 2017	36
M194	Harmonic Mixer	Hewlett Packard	11970V	2521A01005	23 Apr 2017	36
A2343	Diplexer	Farran	DIP-1-0001	FTL 3098B	Calibration not required	-
A202	Horn Antenna	Flann	24240-20	116	15 May 2016	12
A1916	Horn Antenna	Flann	25240-25	166399	15 May 2016	12
K0002	3m RSE Chamber	Rainford EMC	N/A	N/A	01 May 2016	12
A1818	Horn Antenna	EMCO	3115	00075692	20 Dec 2015	12
A253	Horn Antenna	Flann	12240-20	128	20 Dec 2015	12
A254	Horn Antenna	Flann	14240-20	139	20 Dec 2015	12
A255	Horn Antenna	Flann	16240-20	519	20 Dec 2015	12
A256	Horn Antenna	Flann	18240-20	400	20 Dec 2015	12
A436	Horn Antenna	Flann	20240-20	330	21 Dec 2015	12
A203	Horn Antenna	Flann	22240-20	343	19 May 2016	36
A1785	Pre Amplifier	Farran	FLNA-28-30	FTL 6483	09 Jan 2016	12
M1874	Test Receiver	Rohde & Schwarz	ESU26	100553	12 Jun 2016	12
M1630	Test Receiver	Rohde & Schwarz	ESU40	100233	20 Feb 2016	12
A1534	Pre Amplifier	Hewlett Packard	8449B	3008A00405	21 Dec 2015	12
S0537	Power Supply	TTi	EL302D	3008A00405	Calibrated before use	-
M1269	Multimeter	Fluke	179	90250210	26 May 2016	12
G0543	Amplifier	Sonoma	310N	230801	10 Feb 2016	3
M1273	Test Receiver	Rohde & Schwarz	ESIB26	100275	19 Mar 2016	12
A490	Antenna	Chase	CBL6111A	1590	30 Apr 2016	12
M1945	Thermohygrometer	JM Handelpunkt	30.5015.01	0112	23 Apr 2016	12
K0001	5m RSE Chamber	Rainford EMC	N/A	N/A	19 Mar 2016	12
A1834	Attenuator	Hewlett Packard	8491B	10444	05 Mar 2016	12
M1656	Thermohygrometer	JM Handelpunkt	30.5015.13	Not stated	23 Apr 2016	12
A2554	Terminator	Micronde	R404610	Not stated	Calibrated before use	-
A2555	Terminator	Micronde	R404610	Not stated	Calibrated before use	-

5.2.6. Transmitter Frequency Stability (Temperature Variation)

Test Summary:

Test Engineer:	Ben Mercer	Test Dates:	16 December 2015 & 17 December 2015
Test Sample Serial Numbers:	311510061 & 3115155009		

FCC Reference:	Part 25.202(d)
Test Method Used:	KDB 971168 Section 9.0 referencing FCC Part 2.1055

Environmental Conditions:

Ambient Temperature (°C):	23 to 25
Ambient Relative Humidity (%):	38 to 49

Note(s):

1. The EUT was configured to transmit a CW tone during frequency stability tests.
2. Frequency stability was measured using the frequency counter function of a spectrum analyser.
3. Temperature was monitored throughout the test with a calibrated digital thermometer.

Test setup:

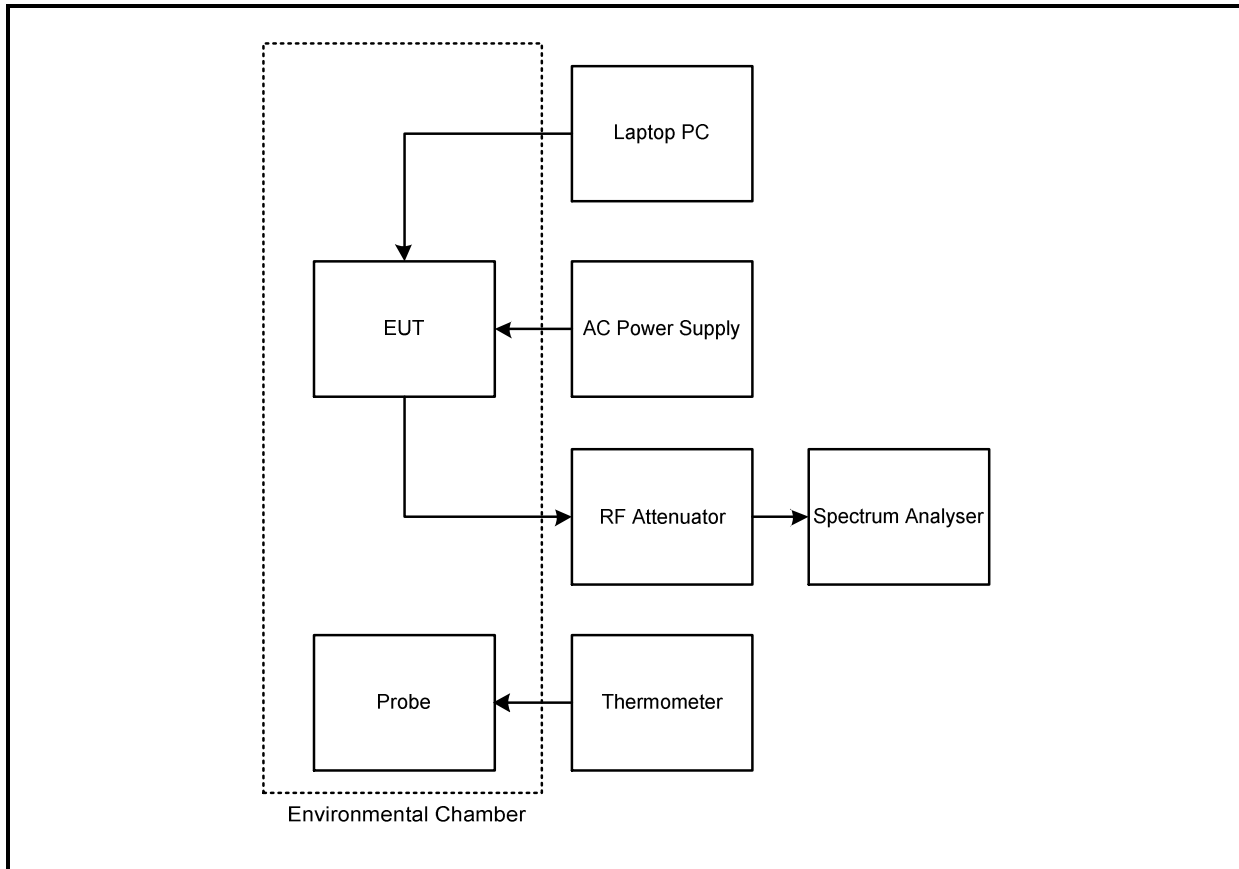

Transmitter Frequency Stability (Temperature Variation)**Results: Middle Channel (14125.0 MHz)**

Temperature (°C)	Measured Frequency (MHz)	Frequency Error (Hz)	Frequency Error (ppm)	Limit (ppm)	Margin (ppm)	Result
-30	14125.001384	1384	0.0980	10.0	9.9020	Complied
-20	14124.999236	764	0.0541	10.0	9.9459	Complied
-10	14124.998343	1657	0.1173	10.0	9.8827	Complied
0	14124.998801	1199	0.0849	10.0	9.9151	Complied
10	14124.998371	1629	0.1153	10.0	9.8847	Complied
20	14124.997340	2660	0.1883	10.0	9.8117	Complied
30	14124.997106	2894	0.2049	10.0	9.7951	Complied
40	14124.997282	2718	0.1924	10.0	9.8076	Complied
50	14124.996929	3071	0.2174	10.0	9.7826	Complied

Test Equipment Used:

Asset No.	Instrument	Manufacturer	Type No.	Serial No.	Date Calibration Due	Cal. Interval (Months)
M1659	Thermohygrometer	JM Handelpunkt	30.5015.13	Not stated	23 Apr 2016	12
M1832	Spectrum Analyser	Agilent	N9010A	MY53470303	26 Mar 2016	24
E0513	Environmental Chamber	TAS	LT600 Series 3	23900506	Calibrated before use	-
M1643	Thermometer	Fluke	52II	18890136	23 Apr 2016	12
A2630	Attenuator	Weinschel	WA75-3-12	A299	Calibrated before use	-
A2631	Attenuator	Weinschel	WA75-6-12	A300	Calibrated before use	-
A2632	Attenuator	Weinschel	WA75-10-12	A301	Calibrated before use	-
A2633	Attenuator	Weinschel	WA75-10-12	A302	Calibrated before use	-

5.2.7. Transmitter Frequency Stability (Voltage Variation)**Test Summary:**

Test Engineer:	Ben Mercer	Test Date:	17 December 2015
Test Sample Serial Numbers:	311510061 & 3115155009		

FCC Reference:	Part 25.202(d)
Test Method Used:	KDB 971168 Section 9.0 referencing FCC Part 2.1055

Environmental Conditions:

Temperature (°C):	25
Relative Humidity (%):	41

Note(s):

1. The EUT was configured to transmit a CW tone during frequency stability tests.
2. Frequency stability was measured using the frequency counter function of a spectrum analyser.
3. A variable transformer was used to vary the AC supply voltage between 85% and 115% of the nominal voltage.
4. Voltage was monitored throughout the test with a calibrated digital voltmeter.

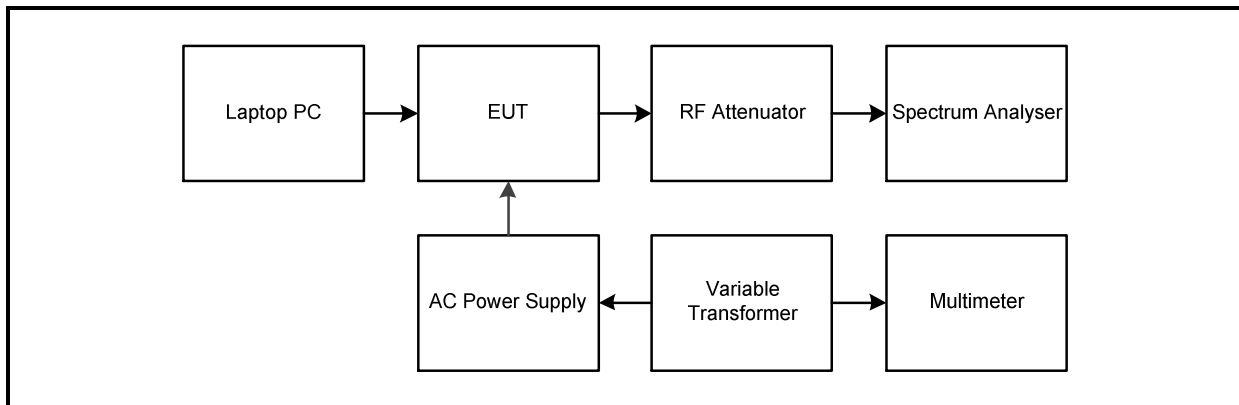
Test setup:**Results: Middle Channel (14125.0 MHz)**

Supply Voltage (V)	Measured Frequency (MHz)	Frequency Error (Hz)	Frequency Error (ppm)	Limit (ppm)	Margin (ppm)	Result
102.0	14124.997653	2347	0.1662	10.0	9.8338	Complied
138.0	14124.997528	2472	0.1750	10.0	9.8250	Complied

Transmitter Frequency Stability (Voltage Variation)**Test Equipment Used:**

Asset No.	Instrument	Manufacturer	Type No.	Serial No.	Date Calibration Due	Cal. Interval (Months)
M1659	Thermohygrometer	JM Handelpunkt	30.5015.13	Not stated	23 Apr 2016	12
M1832	Spectrum Analyser	Agilent	N9010A	MY53470303	26 Mar 2016	24
A2630	Attenuator	Weinschel	WA75-3-12	A299	Calibrated before use	-
A2631	Attenuator	Weinschel	WA75-6-12	A300	Calibrated before use	-
A2632	Attenuator	Weinschel	WA75-10-12	A301	Calibrated before use	-
A2633	Attenuator	Weinschel	WA75-10-12	A302	Calibrated before use	-
A088	Variable Transformer	Zenith	Y20-HM	9029	Calibrated before use	-
M1269	Multimeter	Fluke	179	90250210	26 May 2016	12

6. Measurement Uncertainty

No measurement or test can ever be perfect and the imperfections give rise to error of measurement in the results. Consequently the result of a measurement is only an approximation to the value of the measurand (the specific quantity subject to measurement) and is only complete when accompanied by a statement of the uncertainty of the approximation.

The expression of uncertainty of a measurement result allows realistic comparison of results with reference values and limits given in specifications and standards.

The uncertainty of the result may need to be taken into account when interpreting the measurement results.

The reported expanded uncertainties below are based on a standard uncertainty multiplied by an appropriate coverage factor such that a confidence level of approximately 95% is maintained. For the purposes of this document "approximately" is interpreted as meaning "effectively" or "for most practical purposes".

Measurement Type	Range	Confidence Level (%)	Calculated Uncertainty
Power Spectral Density	13750 MHz to 14500 MHz	95%	±3.66 dB
Occupied Bandwidth	13750 MHz to 14500 MHz	95%	±3.92 %
Conducted Spurious Emissions (Coaxial)	30 MHz to 40 GHz	95%	±4.44 dB
Conducted Spurious Emissions (Waveguide)	40 GHz to 72.5 GHz	95%	±4.10 dB
Radiated Spurious Emissions	30 MHz to 1 GHz	95%	±5.65 dB
Radiated Spurious Emissions	1 GHz to 72.5 GHz	95%	±2.94 dB
Frequency Stability	13750 MHz to 14500 MHz	95%	±0.063 ppm

The methods used to calculate the above uncertainties are in line with those recommended within the various measurement specifications. Where measurement specifications do not include guidelines for the evaluation of measurement uncertainty the published guidance of the appropriate accreditation body is followed.

7. Report Revision History

Version Number	Revision Details		
	Page No(s)	Clause	Details
1.0	-	-	Initial Version
2.0	-	-	Section 5.2.5 block diagram updated
3.0	26 -	- -	Margin updated Terminations added to required equipment lists

--- END OF REPORT ---